

KDR Line Reactor

Variable frequency drives (VFD) are beneficial to a wide range of applications, but contain a power conversion process that creates current and voltage distortion, known as harmonics.

Issues caused by harmonics may include:

- Transformer and distribution equipment overheating
- Random breaker tripping
- Sensitive equipment failure
- Poor power factor

KDR Line Reactor

The KDR Line Reactor offers impedance against the flow of harmonics and other high frequencies that can cause tripping and equipment failure.

Drives and other sensitive devices are protected by the KDR from electrical distortion on the line including harmonics.

Harmonic Current Distortion Without KDR

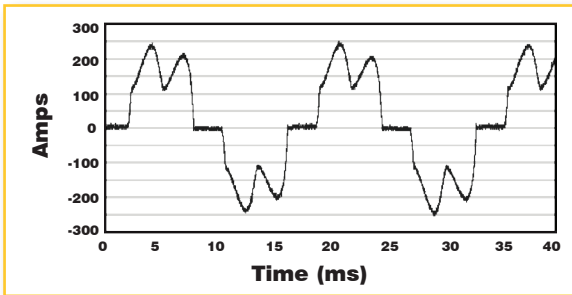

Harmonic Current Distortion With KDR

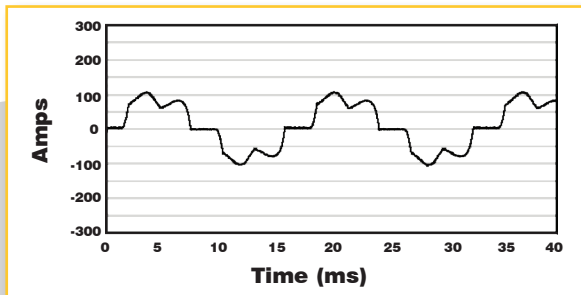

Advantages of the KDR Line Reactor

- Extend the life of the motor on the output of the VFD
- Protect other equipment on the line from operational issues caused by voltage distortion
- Dramatically increase drive uptime by reducing the likelihood of the drive tripping
- Improve power factor
- Reduce motor heating and audible noise
- Increase system productivity
- Meet IEEE 519-2014



Typical Applications

- Pulp & Paper
- Machining
- Wastewater Treatment Plants
- Oil & Gas
- HVAC Systems
- Irrigation Fields, Farms
- Extruders
- Steel Industry

Warranty

Every TCI line reactor is manufactured in Wisconsin with high quality materials and is backed by a lifetime warranty.*

Transient Voltage Without KDR

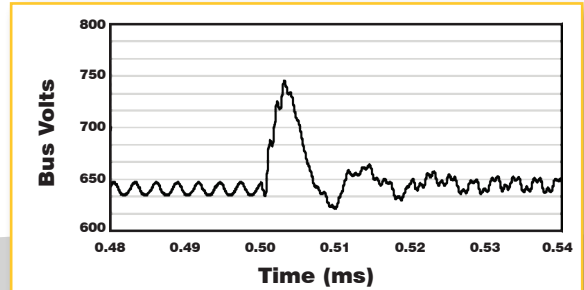

Transient Voltage With KDR

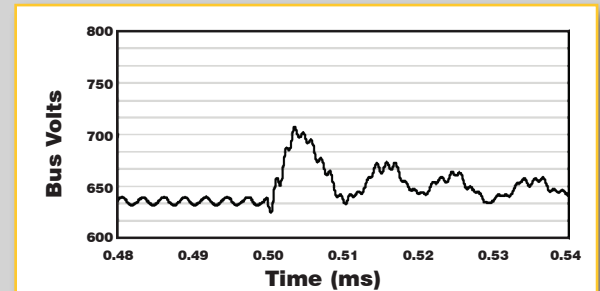

Technical Specifications

Environmental Conditions	
Operating Temperature	Open: 50° C (122° F)
	Enclosed: 40° C (104° F)
Operating Altitude	2,000 m (6,000 ft) Derating necessary above 2,000 m
Reference Technical Standards	
Agency Approvals	cUL, UL; UL Recognized, CE Marked
Fundamental Frequency	50/60 Hz
Impedance Protection	Low "Z" and High "Z"
System Voltage	208/240 VAC, 480 VAC, 575/600 VAC, 690 VAC
Short Term Overload Rating	Tolerate 200% rated I for a minimum of 3 minutes
Inductance Characteristics	Minimum 95% L at 110% Load
	Minimum 80% L at 150% Load
Input and Output	Available for either the line or load side of a VFD
Protection (enclosure)	Open, UL Type 1, UL Type 3R
DIN Rail version available	See website for details

Impedance Options

KDR Line Reactors have been designed to provide the best protection for both your drive and your application. KDR Optimized Drive Reactors are available in two ratings versions, Low "Z" (low impedance) and High "Z" (high impedance). Input impedance can significantly improve drive performance. Select impedance based on the guidelines below:

Use KDR Low "Z" Units For:

Any application where either a 1.5% or 3% reactor would be applied.

Reduction of nuisance tripping caused by:

- Transient voltages caused by capacitor switching
- Line notching
- DC bus overvoltage tripping
- Inverter overcurrent and overvoltage

Additional benefits include:

- Lowering injected percentage of harmonic current
- Improving true power factor
- Reducing cross-talk between drives
- Adding impedance to drives with DC link chokes/ reactors when more impedance is desired due to a relatively stiff source

Performance Guarantee

Properly sized for the application, a KDR reactor is guaranteed to eliminate any AC drive overvoltage tripping problems. If a KDR reactor is installed and the tripping problem remains, TCI will take back the reactor and pay shipping both ways. (Offer valid for 60 days from date of shipment.)

Use KDR High "Z" Units For:

Any application where a 5% reactor would be applied.

KDR High "Z" offers the same superior benefits as Low "Z" plus additional benefits which include:

- Helping prevent drive component damage
- Providing maximum harmonic mitigation without adding capacitance

Part Numbering System

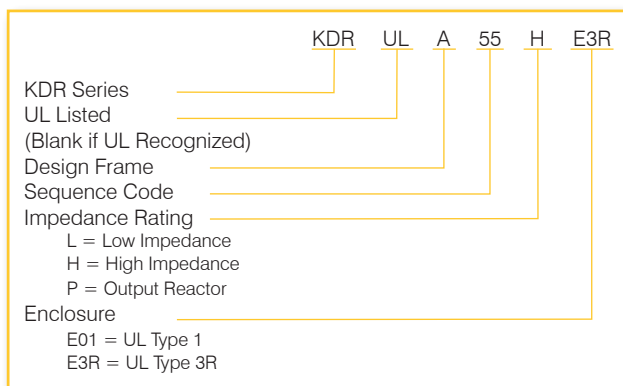

**For the life of the drive*



US LISTED

