

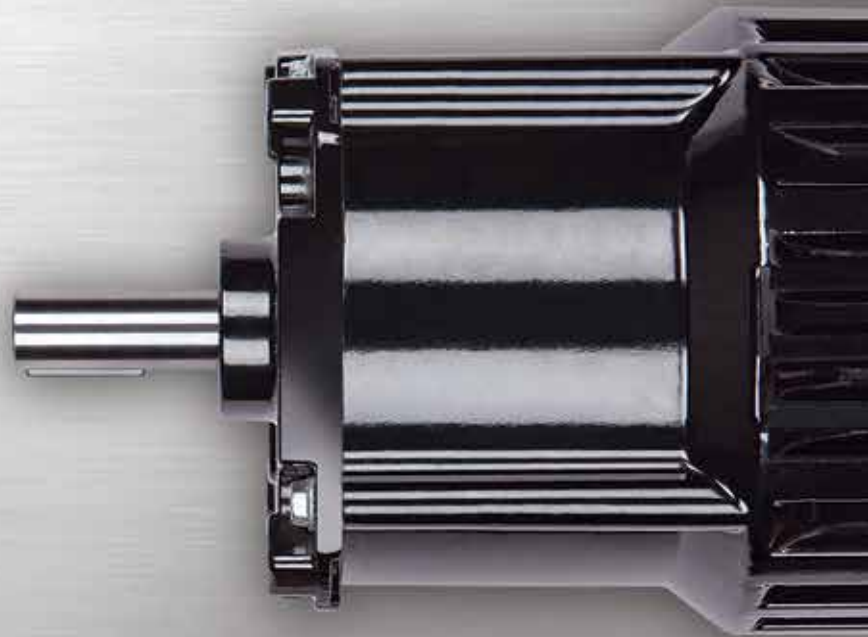

STANDARD PRODUCTS

GEARMOTORS • MOTORS • CONTROLS

AC
PMDC
BLDC



**BODINE
ELECTRIC
COMPANY**

bodine-electric.com

For 2D/3D CAD drawings and distributor locations, go to www.bodine-electric.com

Our website features the latest product specifications, technical documents, connection diagrams and instruction manuals. Dimension drawings and 3D models can be imported from the website directly into most CAD software programs. You will also find information about Bodine's newest products, our distributor locator, and helpful Tech Tools designed to answer the most commonly asked motion control questions.

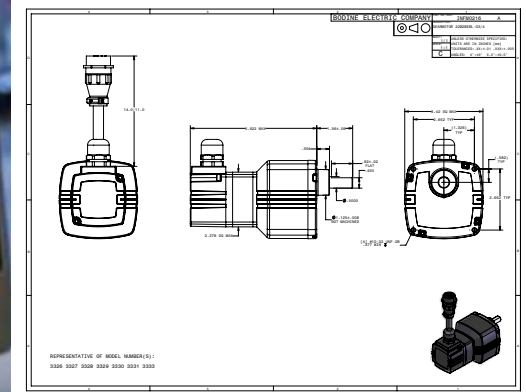
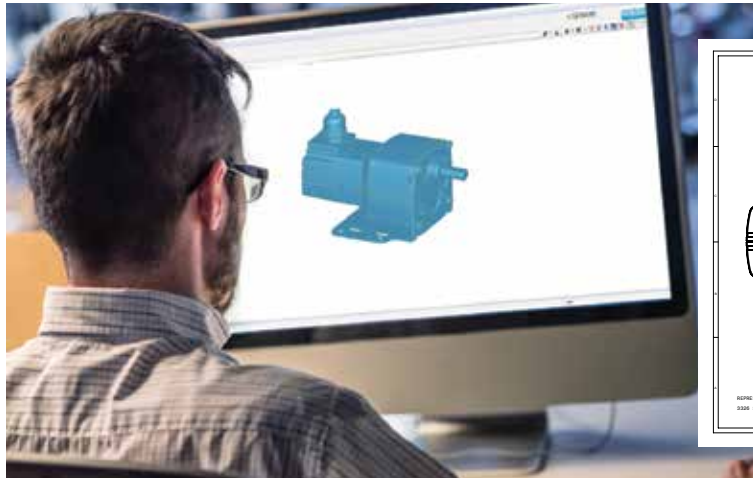

UL/CSA Safety Compliance

RoHS COMPLIANT Products are marked cURus or UR/CSA, and most products meet CE. All products are also RoHS compliant. Motors and gearmotors conform to UL standard 1004 and CSA standard C22.2 No. 100. They are documented in UL file number E47177 and CSA file number LR2797. Electronic controls conform to UL standard 508 and CSA standard C22.2 No. 14. They are documented in UL file number E44529 and CSA file number LR26397.

Motor Options

For the comparative advantages of AC motors and gearmotors, see page 23.

Variable speed AC motors (Inverter Duty)

- 230 VAC, 60 Hz (3-phase) or 230/460 VAC, 60 Hz (3-phase)

Fixed-speed AC motors

- 115 VAC, 60 Hz (single-phase) or 230 VAC, 60 Hz (3-phase)

- Metric voltage ratings are 230 VAC, 50 Hz (1- or 3-phase)
- **Permanent magnet DC motors**
- Voltage ratings are 12/24 VDC, 24 VDC, 90/130 VDC or 130 VDC
- Metric voltage rating is 180 VDC
- Compatible with 90 V controls (90/130 VDC and 130 VDC only)
- **Brushless DC (ECM) motors**
- Voltage ratings are 24 or 130 VDC

NEW SCR rated permanent magnet DC gearmotors

- Voltage ratings are 90 and 180 VDC
- Rated maximum armature speed of 2500 rpm
- Compatible with unfiltered SCR controls

	Variable Speed Inverter Duty AC				Fixed-Speed AC				Permanent Magnet DC			Brushless DC		INTEGRA BLDC		
	30R	34R	42R	48R	K-2	30R	34R	42R	48R	24A	33A	42A	22B	34B	22B	34B
Power (HP)	1/25-1/17	1/8-1/4	3/8	1/3-3/4	1/1600- 1/200	1/40-1/30	1/15-1/5	1/12-1/4	1/5-1/2	1/50-1/7	1/16-1/3	1/4-1/2	1/16-1/5	1/5-3/8	1/16-1/8	1/4
Torque (oz-in.)	24-35	70-148	222	185-445	0.35-3.2	10-20	38-119	48-148	112-296	8-24	34-134	101-180	20-50	33-151	25-50	100
Rated Speed (rpm)	1700	1700, 1800	1700	1700, 1800	1200, 1550, 1800, 3600	1700, 1800, 3400	1700, 1800, 3400	1700, 3450	1700, 1800	2500, 11,500	2500	2500	2500, 10,000	2500, 10,000	2500	2500

© Copyright 2019. Catalog data subject to change without notice. All rights reserved. Printed in the U.S.A.

Table of Contents

Gearmotors

TORQUE	GEARHEAD	SPECIFICATIONS	DIMENSIONS
---------------	-----------------	-----------------------	-------------------

Inline and Parallel Shaft

up to 226 lb-in.	Type 60P	4	38
up to 40 lb-in.	Type D	5	38, 41
up to 120 lb-in.	Type Z	6	39
up to 210 lb-in.	Type WX	7	39
up to 350 lb-in.	Type FX	9	39
up to 350 lb-in.	Type E/F/FX	10	39
up to 1,000 lb-in.	Type HG	11	40
up to 1,000 lb-in.	Type CG	11	40
up to 120 oz-in.	Type A/T (K-2)	12	41



Right Angle

up to 37 lb-in.	Type 3N/3F	13	41
up to 77 lb-in.	Type 5R/5L	14	42
up to 121 lb-in.	Type 5N	15	42
up to 121 lb-in.	Type 5F	17	42
up to 148 lb-in.	Type 3RD	18	43
up to 296 lb-in.	Type 5H	18	42
up to 380 lb-in.	Type GB	19	42
	Hollow Shaft		43



Motors Without Gearing

MOTOR TYPE	POWER	SPECIFICATIONS	DIMENSIONS
-------------------	--------------	-----------------------	-------------------

Torque Motors	from 3.5 to 68 oz-in.	20	45
Variable Speed—AC Pacesetter			
Inverter Duty	from 1/25 to 3/4 HP	21	45
Fixed Speed—AC Induction	up to 1/2 HP	22	45
Permanent Magnet DC	up to 1/2 HP	24	45
Brushless DC	up to 1/2 HP	25	45



Motor Speed Controls

Pacesetter AC Inverters (for 230VAC Motors)	26	47
DC Motor Speed Controls (for 12/24 and 90/130V Motors)	27	47
Brushless DC Controls (for 12/24V and 130V Motors)	30	47



2 Year
system warranty

Accessories 36

Reference Drawings and Dimensions 38

Purchase a Bodine gearmotor and speed control together and get our extended 2-year system warranty.

Metric Motors and Gearmotors

Metric Inline/Planetary

up to 26 Nm	Type 60P	4
-------------	-----------------	---

Metric Parallel Shaft

up to 0.67 Nm	Type A/T (K-2)	31
up to 11.3 Nm	Type D	31
up to 11.3 Nm	Type Z	32
up to 19.8 Nm	Type W	32
up to 35.0 Nm	Type E/F	33

Metric Right Angle

up to 16.7 Nm	Type 3F	33
up to 10.5 Nm	Type 5N/5F	34
up to 14.2 Nm	Type 5H	34
up to 43.0 Nm	Type GB	35

Metric Motors without Gearing

up to 140 Watts	Fixed Speed—AC Induction	35
up to 112 Watts	Permanent Magnet DC	35



Reference

SCR Rated PMDC Gearmotors	16
Hollow Shaft Gearmotor Benefits	19
Safe Operating Torque and Speed Area	21
Common Abbreviations	22
Comparative Advantages of AC Motors and Gearmotors	23
Speed Regulation of Permanent Magnet DC Motors	24

Gearmotors



Inline and Parallel Shaft Gearmotors

60P Inline / Planetary Gearmotors | up to 226 lb-in.

- Twice the torque of conventional helical/spur parallel shaft gearboxes of similar size
- Lower-cost alternative to high-end servo systems
- Unvented gearhousing mounts in any orientation
- Permanently lubricated with high-performance lubricant
- Hardened steel gears for long life. Needle bearings for maximum performance.
- Environmental protection: **24A4-60P:** IP-66 (with shaft seal kit installed); **22B4-60P:** IP-44
- **22B4-60P:** 120° commutation
- **22B4-60P:** Encoder compatible with new screw-in encoder shaft option.
- See page 38 for reference dimensions
- See Page 36 and 37 for accessories

Permanent Magnet DC Gearmotors



Type 24A-60P

All New
PLANETARY
GEARMOTORS

U.S./Imperial Models								
Speed (rpm)	Rated Torque (lb-in.)	Rate Current (Amps)	Peak Torque (lb-in.)	Power (HP)	Gear Ratio	Radial Load (lbs.)	Product Type	Item Number

90/130VDC, Totally Enclosed, Non-ventilated, Class F Insulation

11/15	176/226	0.56 / 0.81	315	1/23 / 1/11	162:1	145	24A4BEPM-60P3	7011
19/28	96/151		278		89:1	120	24A4BEPM-60P3	7009
27/39	72/113		254		64:1	107	24A4BEPM-60P2	7008
57/83	34/54		245		30:1	86	24A4BEPM-60P2	7006
101/147	19/30		182		17:1	72	24A4BEPM-60P2	7004
136/197	14/22		136		13:1	66	24A4BEPM-60P2	7003
216/313	10/15		91		8:1	56	24A4BEPM-60P1	7002
454/658	4.6/7.1		43		4:1	44	24A4BEPM-60P1	7001

Metric Models								
(1/min)	(Nm)	(Amps)	(Nm)	(Watts)	(i)	(N)	Product Type	Item No.

24VDC, Totally Enclosed, Non-ventilated, Class F Insulation

15	26	4.1	36	63	162:1	645	24A4BEPM-60P3	7411
28	16		31		89:1	538	24A4BEPM-60P3	7409
39	12		29		64:1	480	24A4BEPM-60P2	7408
82	5.5		28		30:1	387	24A4BEPM-60P2	7406
146	3.1		20		17:1	320	24A4BEPM-60P2	7404
197	2.3		15		13:1	294	24A4BEPM-60P2	7403
313	1.5		10		8:1	249	24A4BEPM-60P1	7402
658	0.7		5		4:1	196	24A4BEPM-60P1	7401

12VDC, Totally Enclosed, Non-ventilated, Class F Insulation

15	19	6.9	36	46	162:1	658	24A4BEPM-60P3	7211
28	11		31		89:1	547	24A4BEPM-60P3	7209
39	8		29		64:1	489	24A4BEPM-60P2	7208
82	4		19		30:1	391	24A4BEPM-60P2	7206
146	2		10		17:1	325	24A4BEPM-60P2	7204
197	1.6		8		13:1	294	24A4BEPM-60P2	7203
313	1.1		5		8:1	254	24A4BEPM-60P1	7202
658	0.5		2		4:1	196	24A4BEPM-60P1	7201

Ratings are based on operation from DC power. Performance may vary with a speed control.

Brushless DC Gearmotors



Type 22B-60P

U.S./Imperial Models								
Speed (rpm)	Rated Torque (lb-in.)	Rate Current (Amps)	Peak Torque (lb-in.)	Power (HP)	Gear Ratio	Radial Load (lbs.)	Product Type	Item Number

130VDC, Totally Enclosed, Non-ventilated, Class B, Encoder Shaft Option; IP-44

15	226	0.88	315	1/8	162:1	145	22B4FEFL-60P3	7030
28	218		278		89:1	120	22B4FEFL-60P3	7029
39	176		254		64:1	107	22B4FEFL-60P2	7028
82	84		245		30:1	86	22B4FEFL-60P2	7026
146	47		229		17:1	72	22B4FEFL-60P2	7024
197	35		170		13:1	66	22B4FEFL-60P2	7023
313	24		114		8:1	56	22B4FEFL-60P1	7022
658	11		54		4:1	44	22B4FEFL-60P1	7021

Metric Models								
[1/min]	(Nm)	(Amps)	(Nm)	(Watts)	(i)	(N)	Product Type	Item No.

24VDC Totally Enclosed, Non-ventilated, Class B, Encoder Shaft Option; IP-44

15	26	5.6	36	93	162:1	645	22B4FEFL-60P3	7040
28	25		31		89:1	538	22B4FEFL-60P3	7039
39	20		29		64:1	480	22B4FEFL-60P2	7038
82	9.4		28		30:1	387	22B4FEFL-60P2	7036
146	5.3		23		17:1	320	22B4FEFL-60P2	7034
197	3.9		17		13:1	294	22B4FEFL-60P2	7033
313	2.7		12		8:1	249	22B4FEFL-60P1	7032
658	1.3		5		4:1	196	22B4FEFL-60P1	7031

- Universal horizontal mounting
- Helical primary gear and hardened steel spur gearing on subsequent stages
- Capacitors/accessories: Page 36
- Controls: page 26
- Reference dimensions: page 38

Variable Speed—Pacesetter Inverter Duty AC Gearmotors

Fixed Speed Rating					Variable Speed (SOA) Ratings ¹					Product Type	(230V) Model Number	
Speed (rpm)	Torque (lb-in.)	Motor HP	A	Gear Ratio	Speed Range (rpm)	Frequency Range (Hz)	Torque Type	Torque @ 10 Hz (lb-in.)	Torque @ 60 Hz (lb-in.)			Torque @ 90 Hz (lb-in.)
9	40	1/25	0.38	180	1.2-11.65	10-90	constant	40	40	40	30R2BEPP-D4	2210
19	40	1/25	0.38	90	2.5-23			40	40	40	30R2BEPP-D4	N2212
28	40	1/25	0.38	60	3.7-35			40	40	40	30R2BEPP-D3	N2214
142	19	1/17	0.48	12	19-175			19	19	19	30R4BEPP-D3	2216
283	7.4	1/17	0.48	6	22-359			7.4	7.4	7.4	30R4BEPP-D3	N2218



Type 30R-D Pacesetter

Fixed Speed—AC Gearmotors

Speed (rpm)	Rated Torque (lb-in.)	Motor HP	V	Hz	Ph	Amps	Gear Ratio	Radial Load (lbs.)	Capacitor (µF/VAC)	Product Type	Model Number
Permanent Split Capacitor, Non-synchronous											
3.8	40	1/50	115	60	1	0.33	450	65	4.0/250	30R1BECEI-D5	5463
9.4	40	1/50				0.33	180		4.0/250	30R1BECEI-D4	5462
19	40	1/50				0.33	90		4.0/250	30R1BECEI-D4	5461
28	40	1/30				0.45	60		5.0/250	30R2BECEI-D3	5474
57	27	1/30				0.45	30		5.0/250	30R2BECEI-D3	5473
94	16	1/30				0.45	18		5.0/250	30R2BECEI-D3	5472
140	11	1/30				0.45	12		5.0/250	30R2BECEI-D3	5471
285	5	1/30				0.45	6		5.0/250	30R2BECEI-D3	5470



Type 30R-D

Permanent Magnet DC Gearmotors

Speed (rpm)	Rated Torque (lb-in.)	Rated Current (Amps)		Peak Torque (lb-in.)	Motor HP	Gear Ratio	Radial Load (lbs.)	Product Type ²	Accy Shaft		No Accy Shaft	
		24V	130V						24V	130V		
5.6	40	1.8	0.30	55	1/29	450	65	24A2BEPM-D5	N4999	N4799	N4499	0199
8.3	40	1.8	0.30	55	1/29	300		24A2BEPM-D5	N4998	N4798	N4498	0198
14	40	1.8	0.30	55	1/29	180		24A2BEPM-D4	N4997	N4797	N4497	0197
28	40	1.8	0.30	55	1/29	90		24A2BEPM-D4	N4996	N4796	N4496	0196
42	40	2.6	0.48	55	1/17	60		24A4BEPM-D3	—	4690	—	0190
42	36	1.8	0.30	55	1/29	60		24A2BEPM-D3	N4995	N4795	N4495	0195
83	29	2.6	0.48	33	1/17	30		24A4BEPM-D3	—	—	—	0189
83	18	1.8	0.30	33	1/29	30		24A2BEPM-D3	N4994	N4794	N4494	0194
139	17	2.6	0.48	20	1/17	18		24A4BEPM-D3	—	—	—	0188
139	11	1.8	0.30	20	1/29	18		24A2BEPM-D3	N4993	N4793	N4493	0193
208	12	2.6	0.48	13	1/17	12		24A4BEPM-D3	—	—	—	0187
208	7.1	1.8	0.30	13	1/29	12		24A2BEPM-D3	N4992	N4792	N4492	0192
417	5.4	2.6	0.48	6.2	1/17	6		24A4BEPM-D3	—	—	—	0186
417	3.3	1.8	0.30	6.2	1/29	6		24A2BEPM-D3	N4991	N4791	N4491	0191



Type 24A-D

Brushless DC Gearmotors

Speed (rpm)	Rated Torque (lb-in.)	Rated Current (A)		Peak Torque (lb-in.)	Motor HP	Gear Ratio	Radial Load (lbs.)	Product Type	Accy Shaft		No Accy Shaft	
		24V	130V						24V	130V		
14	40	3.3	0.53	55	1/16	180	60	22B2BEEL-D4	N3636	N3536	N3433	3333
28	40			55		90		22B2BEEL-D4	N3635	N3535	N3431	N3331
42	40			55		60		22B2BEEL-D3	N3634	N3534	N3430	N3330
83	29			33		30		22B2BEEL-D3	3629	N3529	N3429	3329
139	17			20		18		22B2BEEL-D3	N3628	N3528	N3428	N3328
208	12			13		12		22B2BEEL-D3	N3627	N3527	N3427	3327
417	5.8	6.2	6	22B2BEEL-D3	N3626	N3526	N3426	3326				



Type 22B-D

INTEGRAmotor BLDC Gearmotors

Motor Output				Control Input			Product Type	Model Number	
Speed Range (rpm)		Torque (lb-in.)	Gear Ratio	HP	Volts (VDC)	Continuous Amps		Type SR	Type FV
Type SR	Type FV						Analog Interface	Digital Interface ³	
0.7-8	0.3-8	40	300	1/16	24	3.3	22B2BEEL/**-D5	N3837	N3737
1-14	0.4-14	40	180				22B2BEEL/**-D4	3836	N3736
2-28	0.8-28	40	90				22B2BEEL/**-D4	N3835	N3735
3-42	1.3-42	40	60				22B2BEEL/**-D3	N3834	N3734
7-83	2.5-83	29	30				22B2BEEL/**-D3	3829	N3729
11-139	4.2-139	17	18				22B2BEEL/**-D3	N3828	N3728
17-208	6.3-208	12	12				22B2BEEL/**-D3	3827	N3727
33-417	13-417	5.8	6				22B2BEEL/**-D3	3826	N3726



Type 22B/SR-D and 22B/FV-D INTEGRAmotor

¹ SOA: Contact the factory for detailed speed/torque information (Safe Operating Area). See page 21; ² The fifth character of the product type changes from "B" to "F" for accessory ready models; ³ Type FV INTEGRAmotors require a PWM signal from a motion controller or PLC to operate; ** INTEGRAmotor can be ordered with either analog (/SR) or digital (/FV) interface option; "N" model numbers require lead time and minimum quantities.

- Unvented gearhousing for universal horizontal mounting
- Permanently lubricated with high-performance lubricant
- Helical primary gear for quietness and hardened steel spur gearing on subsequent stages for high output torque and long life
- Models with accessory shafts are ideal for mounting encoders or brakes
- See Page 36 for capacitors and accessories
- See page 39 for reference dimensions

Variable Speed – Pacesetter Inverter Duty AC Gearmotors



Type 34R-Z Pacesetter

Fixed Speed Rating					Variable Speed (SOA) Ratings ¹						Product Type	(230V) Model Number
Speed (rpm)	Torque (lb-in.)	Motor HP	A	Gear Ratio	Speed Range (rpm)	Frequency Range (Hz)	Torque Type	Torque @ 10 Hz (lb-in.)	Torque @ 60 Hz (lb-in.)	Torque @ 90 Hz (lb-in.)		
Three-Phase, Inverter Duty, Non-synchronous, 230 VAC (TENV)												
9	120	1/6	0.73	180	0.9-13	10-90	constant	120	120	120	34R6BEPP-Z4	2220
19	120			90	1.8-26			120	120	120	34R6BEPP-Z4	N2222
28	120			60	2.8-39			120	120	120	34R6BEPP-Z3	N2224
57	96			30	5.5-78			96	96	96	34R6BEPP-Z3	2226
94	39			18	16-143			39	39	39	34R6BEPP-Z2	N2227
283	21			6	28-391			21	21	21	34R6BEPP-Z2	N2228

Fixed Speed – AC Gearmotors



Type 34R-Z

Speed (rpm)	Rated Torque (lb-in.)	Motor HP	V	Hz	Ph	Amps	Gear Ratio	Radial Load (lbs.)	Capacitor (µF/VAC)	Product Type	Model Number
Permanent Split Capacitor, Non-synchronous											
CAPACITOR IS REQUIRED											
9.6	100	1/15	115	60	1	1.0	180	125	10.0/250	34R4BFCI-Z4	0449
19	100						90	125		34R4BFCI-Z4	0448
28	100						60	125		34R4BFCI-Z3	0455
57	57						30	125		34R4BFCI-Z3	0454
94	36						18	100		34R4BFCI-Z2	0453
142	24						12	100		34R4BFCI-Z2	0452
283	12	6	100	34R4BFCI-Z2	0451						

Permanent Magnet DC Gearmotors



Type 24A-Z



Type 33A-Z

Speed (rpm)	Rated Torque (lb-in.)	Rated Current (Amps)		Peak Torque (lb-in.)	Motor HP	Gear Ratio	Radial Load (lbs.)	Product Type ²	Accy Shaft	No Accy Shaft	Accy Shaft	No Accy Shaft
		24V	130V						24V	130V		
24A-Z PMDC Gearmotor												
14	100	2.6	0.48	115	1/17	180	125	24A4BEPM-Z4	N4963	4663	N4563	0163
28	92			90		125	24A4BEPM-Z4	N4962	N4662	N4562	0162	
42	65			60		125	24A4BEPM-Z3	N4961	4661	N4561	0161	
83	33			30		125	24A4BEPM-Z3	N4960	4660	N4560	0160	
139	21			18		100	24A4BEPM-Z2	N4959	N4659	N4559	0159	
208	14			12		100	24A4BEPM-Z2	N4958	N4658	N4558	0158	
417	7	6	100	24A4BEPM-Z2	N4957	4657	N4557	N0157				
33A-Z PMDC Gearmotor												
42	95	3.7	0.74	115	1/12	60	125	33A3BEPM-Z3	N6969	N6669	N6569	6169
83	47			30		125	33A3BEPM-Z3	N6968	N6668	N6568	6168	
139	31			18		100	33A3BEPM-Z2	N6967	N6667	N6567	6167	
208	20			12		100	33A3BEPM-Z2	N6966	N6666	N6566	6166	
417	10			6		100	33A3BEPM-Z2	N6965	N6665	N6565	6165	

SCR Rated – Permanent Magnet DC Gearmotors

90V and 180VDC gearmotors with a maximum rated armature speed of 2500 rpm.



Type 24A-Z, SCR Rated



Type 33A-Z SCR Rated

Speed (rpm)	Rated Torque (lb-in.)	Rated Current (Amps)		Form Factor		Peak Torque (lb-in.)	Motor HP		Gear Ratio	Radial Load (lbs.)	Product Type	Model Number	
		90V	180V	90V	180V		90V	180V				90V	180V
Maximum Rated Armature Speed: 2500 rpm													
24A-Z PMDC Gearmotor													
14	120	0.58	0.3	1.6	1.5	139	1/20	1/19	180	166	24A4BEPM-Z4	1245	1236
28	77					126			90	193	24A4BEPM-Z4	1243	1235
42	55					137			60	207	24A4BEPM-Z3	1242	1234
83	27					120			30	225	24A4BEPM-Z3	1241	1233
139	18					48			18	142	24A4BEPM-Z2	1239	1232
208	12					44			12	145	24A4BEPM-Z2	1238	1231
417	6	20	6	147	24A4BEPM-Z2	1237	1230						
33A-Z PMDC Gearmotor													
42	120	1.6	0.8	1.4	1.4	137	1/7	1/7	60	166	33A5BEPM-Z3	1189	1179
83	87					120			30	187	33A5BEPM-Z3	1188	1178
139	39					48			18	132	33A5BEPM-Z2	1186	1177
208	36					44			12	132	33A5BEPM-Z2	1185	1176
417	19					20			6	137	33A5BEPM-Z2	1184	1175

Brushless DC Gearmotors

Speed (rpm)	Rated Torque (lb-in.)	Rated Current (Amps)		Peak Torque (lb-in.)	Motor HP	Gear Ratio	Radial Load (lbs.)	Product Type ²	Accy Shaft	No Accy Shaft	Accy Shaft	No Accy Shaft
		24V	130V						24V	130V		
14	100	—	0.72	115	1/11	180	110	22B3BEBL-Z4	—	—	N3463	3363
14	100	3.3	0.53	115	1/16	180	110	22B2BEBL-Z4	—	N3563	—	—
21	100	3.3	0.53	115	1/16	120	110	22B2BEBL-Z4	—	N3564	—	N3364
28	100	4.4	0.72	115	1/11	90	110	22B3BEBL-Z4	—	—	N3462	N3362
28	97	3.3	0.53	115	1/16	90	110	22B2BEBL-Z4	—	N3562	—	—
42	95	4.4	0.72	115	1/11	60	110	22B3BEBL-Z3	3661	N3561	N3461	N3361
83	52	4.4	0.72	59	1/11	30	125	22B3BEBL-Z3	N3660	N3560	N3460	N3360
139	31	4.4	0.72	38	1/11	18	125	22B3BEBL-Z2	N3659	N3559	N3459	N3359
208	20	4.4	0.72	25	1/11	12	120	22B3BEBL-Z2	N3658	N3558	N3458	3358
417	10	4.4	0.72	13	1/11	6	100	22B3BEBL-Z2	N3657	N3557	N3457	3357



Type 22B-Z

INTEGRAmotor BLDC Gearmotors

Motor Output				Control Input			Product Type	Model Number	
Speed Range (rpm)		Torque (lb-in.)	Gear Ratio	HP	Volts (VDC)	Continuous Amps		Type SR	Type FV
Type SR	Type FV							Analog Interface	Digital Interface ³
0.7-8	0.3-8	100	300	1/16	24	3.3	22B2BEBL/**-Z4	N3864	N3764
1-14	0.4-14	100	180	1/16		3.3	22B2BEBL/**-Z4	3863	N3723
2-28	0.8-28	97	90	1/16		3.3	22B2BEBL/**-Z4	N3862	N3762
3-42	1.3-42	95	60	1/11		4.4	22B3BEBL/**-Z3	N3861	N3761
7-83	2.5-83	52	30	1/11		4.4	22B3BEBL/**-Z3	3860	N3760
11-139	4.2-139	31	18	1/11		4.4	22B3BEBL/**-Z2	N3859	N3759
17-208	6.3-208	20	12	1/11		4.4	22B3BEBL/**-Z2	N3858	N3758
33-417	13-417	10	6	1/11		4.4	22B3BEBL/**-Z2	3857	N3757



Type 22B/SR-Z and 22B/FV-Z INTEGRAmotor

** INTEGRAmotor can be ordered with either analog (/SR) or digital (/FV) interface option;

up to 210 lb-in. | Parallel Shaft Gearmotors



- Up to 65% more torque than previous models
- Unvented gearhousing
- Selectively hardened steel helical gears
- Synthetic lubricant
- Models with accessory shafts are ideal for mounting encoders or brakes
- Adaptor plate, model 0995, allows for 3-hole mounting configuration. See Page 36
- See Page 36 for capacitors and accessories
- See page 36 for reference dimensions

Fixed Speed—AC Gearmotors

Speed (rpm)	Rated Torque (lb-in.)	Motor HP	V	Hz	Ph	Amps	Gear Ratio	Radial Load (lbs.)	Capacitor (µF/VAC)	Product Type	Model Number
Permanent Split Capacitor, Non-synchronous, 3-Wire-Reversible (TEFC)											
5	210	1/7	115	60	1	1.7	312	130	27.5/250	34R6BFCI-WX4	1034
10	200						172	130		34R6BFCI-WX4	1032
17	195						98	130		34R6BFCI-WX4	1029
26	195						66	130		34R6BFCI-WX3	1027
31	190						55	130		34R6BFCI-WX3	1025
39	157						44	130		34R6BFCI-WX3	1023
57	106						30	130		34R6BFCI-WX3	1021
83	77						20	65		34R6BFCI-WX2	1019
123	46						14	65		34R6BFCI-WX2	1016
181	31						9	65		34R6BFCI-WX2	1014
309	18						6	65		34R6BFCI-WX2	1012
447	9						4	65		34R6BFCI-WX2	1010



Type 34R-WX

¹ SOA: Contact the factory for detailed speed/torque information (Safe Operating Area). See page 21; ² The fifth character of the product type changes from "B" to "F" for accessory ready models; ³ Type FV INTEGRAmotors require a PWM signal from a motion controller or PLC to operate; "N" model numbers require lead time and minimum quantities.

Permanent Magnet DC Gearmotors



Type 33A-WX

Speed (rpm)		Rated Torque (lb-in.)	Amps		HP		FF	Gear Ratio	Radial Load (lbs.)	Product Type ²	Accy	No	Accy	No
12/24V	90/130V		12/24V	90/130V	12/24V	90/130V					12/24V	90/130V		
2.9 / 8.0	5 / 8	205	10.2	1.3 / 1.7	1/11 / 1/4	1/8 / 1/4	1.4 / 1.0	312	130	33A5BEPM-WX4	1422	1222	1452	1072
5 / 15	10 / 15	200						172	130	33A5BEPM-WX4	1420	1220	1450	1070
9 / 26	17 / 26	185						98	130	33A5BEPM-WX4	1418	1218	1448	1068
14 / 38	26 / 38	190						66	130	33A5BEPM-WX3	1416	1216	1446	1066
16 / 46	31 / 46	185						55	130	33A5BEPM-WX3	1414	1214	1444	1064
21 / 57	39 / 57	157						44	130	33A5BEPM-WX3	1412	1212	1442	1062
30 / 84	57 / 84	106						30	130	33A5BEPM-WX3	1410	1210	1440	1060
44 / 123	83 / 123	77						20	65	33A5BEPM-WX2	1408	1208	1438	1058
65 / 181	123 / 181	46						14	65	33A5BEPM-WX2	1406	1206	1436	1056
96 / 266	181 / 266	31						9	65	33A5BEPM-WX2	1404	1204	1434	1054
164 / 455	309 / 455	18						6	65	33A5BEPM-WX2	1402	1202	1432	1052
237 / 658	447 / 658	9						4	65	33A5BEPM-WX2	1400	1200	1430	1050

SCR Rated—Permanent Magnet DC Gearmotors



Type 33A-WX / SCR Rated

90V and 180VDC gearmotors with a maximum rated armature speed of 2500 rpm.

Speed (rpm) ¹	Rated Torque (lb-in.)	Rated Current (Amps)		Form Factor		Motor HP		Gear Ratio	Peak Torque (lb-in.)	Radial Load (lbs.)	Product Type	Model Number	
		90V	180V	90V	180V	90V	180V					90V	180V
8.0	205	1.6	0.8	1.4	1.4	1/7	1/7	312	350	300	33A5BEPM-WX4	1259	1172
15	200							172	350	300	33A5BEPM-WX4	1247	1170
26	185							98	350	261	33A5BEPM-WX4	1257	1168
38	190							66	350	223	33A5BEPM-WX3	1256	1166
46	163							55	350	217	33A5BEPM-WX3	1255	1164
57	131							44	327	213	33A5BEPM-WX3	1254	1162
84	88							30	220	201	33A5BEPM-WX3	1253	1169
123	64							20	160	185	33A5BEPM-WX2	1252	1158
181	39							14	97	172	33A5BEPM-WX2	1251	1154
266	26							9	65	156	33A5BEPM-WX2	1250	1153
455	15							6	37	135	33A5BEPM-WX2	1249	1152
658	9							4	22	122	33A5BEPM-WX2	1248	1150

Brushless DC Gearmotors



Type 34B-WX

Speed (rpm)	Rated Torque (lb-in.)	Rated Current (Amps)		Motor HP	Gear Ratio	Radial Load (lbs.)	Product Type ²	Accy Shaft	No Accy Shaft	Accy Shaft	No Accy Shaft
		24V	130V					24V	130V		
8	205	9.0	1.4	1/5	312	130	34B3BEBL-WX4	1323	1293	1123	1093
15	200				172	130	34B3BEBL-WX4	1322	1292	1122	1092
26	185				98	140	34B3BEBL-WX4	1320	1290	1120	1090
38	190				66	140	34B3BEBL-WX3	1318	1288	1118	1088
46	185				55	130	34B3BEBL-WX3	1317	1287	1117	1087
57	157				44	130	34B3BEBL-WX3	1316	1286	1116	1086
84	106				30	160	34B3BEBL-WX3	1315	1285	1115	1085
123	77				20	60	34B3BEBL-WX2	1314	1284	1114	1084
181	46				14	65	34B3BEBL-WX2	1313	1283	1113	1083
266	31				9	80	34B3BEBL-WX2	1312	1282	1112	1082
455	18				6	90	34B3BEBL-WX2	1310	1280	1110	1080
658	9				4	65	34B3BEBL-WX2	1309	1279	1109	1079

INTEGRAmotor BLDC Gearmotors



Type 34B/SR-WX INTEGRA

Designed for Class I/Division 2 and remote & mobile applications

Speed (rpm)	Torque (lb-in.)	HP		Gear Ratio	Radial Load (lbs)	Control Input Cont. Amps		Product Type	12 VDC Model No.	24 VDC Model No.
		12 VDC	24 VDC			12 VDC	24 VDC			
8	205	1/5	1/4	312	130	19.0	11.0	34B4BEBL/SR-WX4	B3293	B3893
15	200			172	130			34B4BEBL/SR-WX4	B3292	B3892
26	185			98	140			34B4BEBL/SR-WX4	B3290	B3890
38	190			66	140			34B4BEBL/SR-WX3	M3288	M3888
46	185			55	130			34B4BEBL/SR-WX3	B3287	B3887
57	157			44	130			34B4BEBL/SR-WX3	M3286	M3886
84	106			30	160			34B4BEBL/SR-WX3	B3285	B3885
123	77			20	60			34B4BEBL/SR-WX2	B3284	B3884
181	46			14	65			34B4BEBL/SR-WX2	B3283	B3883
266	31			9	80			34B4BEBL/SR-WX2	B3282	B3882
455	18			6	90			34B4BEBL/SR-WX2	B3280	B3880
658	9			4	65			34B4BEBL/SR-WX2	B3279	M3879

¹"M" model numbers require a 5-piece minimum order, 20-day lead-time; ²"B" model numbers require a 25-piece minimum order, 25-day lead-time; ³The fifth character of the product type changes from "B" to "F" for accessory ready models;

- FX and F-type: hardened helical gearing for quietness and high output to size ratio
- Unvented gearhousing for universal horizontal mounting
- Models with accessory shafts are ideal for mounting encoders or brakes
- Page 36: capacitors and accessories
- Page 39: reference dimensions

Variable Speed—Pacesetter Inverter Duty AC Gearmotors

Fixed Speed Rating						Variable Speed (SOA) Ratings ¹						Product Type	230V Model No.	230/460V Model No.
Speed (rpm)	Torque (lb-in.)	HP	(230V) Amps	(230/460V) Amps	Gear Ratio	Speed Range (rpm)	Frequency Range (Hz)	Torque Type	Torque @ 10 Hz (lb-in.)	Torque @ 60 Hz (lb-in.)	Torque @ 90 Hz (lb-in.)			
34R-FX Pacesetter Gearmotor														
Three-Phase, Inverter Duty, Non-synchronous (TEFC)														
5.7	350	1/6	1.0	1.0/0.5	300	0.4-7.3	10-90	constant	350	350	350	34R4BFPP-FX4	N2256	2856
9.4	350				180	0.7-12		constant	350	350	350	34R4BFPP-FX4	2250	2850
19	350				90	1.3-24		constant	350	350	350	34R4BFPP-FX4	2251	2851
28	321				60	2.0-36		variable	256	350	350	34R4BFPP-FX3	2252	2852
57	160				30	4.0-73		variable	128	255	221	34R4BFPP-FX3	2253	2853
170	53				10	12-218		variable	43	85	74	34R4BFPP-FX2	N2254	2854
340	28				5	24-436		variable	22	44	38	34R4BFPP-FX1	N2255	2855
42R-FX Pacesetter Gearmotor														
Three-Phase, Inverter Duty, Non-synchronous (TEFC)														
57	270	3/8	1.9	1.9/0.95	30	5.9-77	10-90	constant	270	270	270	42R6BFPP-FX3	2260	2860
85	240				20	8.8-115		variable	187	240	240	42R6BFPP-FX3	2261	2861
113	184				15	12-153		variable	140	186	186	42R6BFPP-FX2	N2264	2864
170	123				10	18-229		variable	93	124	124	42R6BFPP-FX2	2262	2862
340	58				5	35-459		variable	48	58	58	42R6BFPP-FX1	2263	2863



Type 34R-FX Pacesetter



Type 42R-FX Pacesetter

Fixed Speed—AC Gearmotors

Speed (rpm)	Rated Torque (lb-in.)	Motor HP	V	Hz	Ph	Amps	Gear Ratio	Radial Load (lbs.)	Capacitor (µF/VAC)	Product Type	Model Number
42R-FX Fixed Speed AC Gearmotors											
Permanent Split Capacitor, Three-Wire Reversible, Non-Synchronous CAPACITOR IS REQUIRED											
5.7	350	1/4	115	60	1	2.9	300	200	45.0/250	42R6BFCI-FX4	5671
9.4	350						180	200		42R6BFCI-FX4	5669
14	350						120	200		42R6BFCI-FX4	5668
28	350						60	200		42R6BFCI-FX3	5685
57	243						30	300		42R6BFCI-FX3	5683
85	162						20	300		42R6BFCI-FX3	5681
115	122						15	300		42R6BFCI-FX2	5682
170	81	10	300	42R6BFCI-FX2	5680						
340	42	5	60	42R6BFCI-FX1	5679						
48R-FX Fixed Speed AC Gearmotor											
Permanent Split Capacitor, Non-synchronous CAPACITOR IS REQUIRED											
57	270	1/3	115/230	60	1	4.0/2.0	30	300	115V=20.0/370 230V=12.5/370	48R6BFSI-FX3	N5694
85	218						20	300		48R6BFSI-FX3	N5693
113	164						15	300		48R6BFSI-FX2	N5695
170	109						10	300		48R6BFSI-FX2	N5692
340	56						5	60		48R6BFSI-FX1	N5691
48R-FX Fixed Speed AC Gearmotor											
Split Phase (with centrifugal switch), Non-synchronous											
57	270	1/3	115/230	60	1	4.8/2.4	30	300	—	48R6BFSI-FX3	0664
85	218						20	300		48R6BFSI-FX3	0663
170	109						10	300		48R6BFSI-FX2	0662
340	56						5	60		48R6BFSI-FX1	0661



Type 42R-FX



Type 48R-FX

¹ SOA: Contact the factory for detailed speed/torque information (Safe Operating Area). See page 21; ² The fifth character of the product type changes from "B" to "F" for accessory ready models; ³ Type FV INTEGRAmotors require a PWM signal from a motion controller or PLC to operate; ** INTEGRAmotor can be ordered with either analog (/SR) or digital (/FV) interface option; "N" model numbers require lead time and minimum quantities.

Permanent Magnet DC Gearmotors

Speed (rpm)	Rated Torque (lb-in.)	Rated Current (Amps)		Peak Torque (lb-in.)	Motor HP	FF	Gear Ratio	Radial Load (lbs.)	Product Type ²	Accy Shaft	No Accy Shaft	Accy Shaft	No Accy Shaft	
										12/24V	90/130V			
42A-FX Gearmotor														
<i>90/130V Class F Temperature Rating</i>														
6 / 8	350 / 350	2.1 / 2.8		500	3/16 / 3/8	1.4 / 1.0	300	200	42A5BEPM-FX4	—	—	5059	5049	
10 / 14	350 / 350			500				180	200	42A5BEPM-FX4	—	—	5058	5048
14 / 21	350 / 350			500				120	200	42A5BEPM-FX4	—	—	5057	5047
29 / 42	350 / 350			450				60	200	42A5BEPM-FX3	—	—	5056	5046
43 / 63	239 / 265			320				40	300	42A5BEPM-FX3	—	—	5055	5045
58 / 83	179 / 248			400				30	300	42A5BEPM-FX3	—	—	5054	5044
86 / 125	119 / 165			270				20	300	42A5BEPM-FX3	—	—	5053	5043
115 / 167	89 / 124			290				15	300	42A5BEPM-FX2	—	—	5052	5042
173 / 250	60 / 83			195				10	300	42A5BEPM-FX2	—	—	5051	5041
345 / 500	31 / 43			72				5	60	42A5BEPM-FX1	—	—	5050	5040
<i>12/24V Class F Temperature Rating</i>														
3 / 8	350	14		500	1/7 / 3/8	1.0	300	200	42A5BEPM-FX4	5079	5069	—	—	
6 / 14	350			500				180	200	42A5BEPM-FX4	5078	5068	—	—
8 / 21	350			500				120	200	42A5BEPM-FX4	5077	5067	—	—
17 / 42	350			450				60	200	42A5BEPM-FX3	5076	5066	—	—
25 / 63	265			320				40	300	42A5BEPM-FX3	5075	5065	—	—
33 / 83	248			400				30	300	42A5BEPM-FX3	5074	5064	—	—
50 / 125	165			270				20	300	42A5BEPM-FX3	5073	5063	—	—
67 / 167	124			290				15	300	42A5BEPM-FX2	5072	5062	—	—
100 / 250	83			195				10	300	42A5BEPM-FX2	5071	5061	—	—
200 / 500	43			72				5	60	42A5BEPM-FX1	5070	5060	—	—



Type 42A5-FX

SCR Rated—Permanent Magnet DC Gearmotors

Speed (rpm) ¹	Rated Torque (lb-in.)	Rated Current (Amps)		Form Factor		Motor HP		Gear Ratio	Peak Torque (lb-in.)	Radial Load (lbs.)	Product Type	Model Number	
		90V	180V	90V	180V	90V	180V					90V	180V
8.3	350	2.2	1.2	1.5	1.6	1/4	1/4	300	500	214	42A5BEPM-FX4	1510	5149
14	350							180	500	214	42A5BEPM-FX4	1509	5148
21	350							120	500	214	42A5BEPM-FX4	1508	5147
42	290							60	470	233	42A5BEPM-FX3	1507	5146
63	194							40	335	254	42A5BEPM-FX3	1506	5145
83	145							30	400	281	42A5BEPM-FX3	1505	5144
125	97							20	280	292	42A5BEPM-FX3	1504	5143
167	73							15	290	300	42A5BEPM-FX2	1503	5142
250	48							10	195	300	42A5BEPM-FX2	1502	5141
500	25							5	72	48	42A5BEPM-FX1	1501	5140



Type 42A5-FX / SCR Rated

90V and 180VDC gearmotors with a maximum rated armature speed of 2500 rpm.

Brushless DC Gearmotors

Speed (rpm)	Rated Torque (lb-in.)	Rated Current (Amps)		Peak Torque (lb-in.)	Motor HP	Gear Ratio	Radial Load (lbs.)	Product Type ^{2,3}	Accy Shaft	No Accy Shaft	Accy Shaft	No Accy Shaft
		24V	130V						24V	130V		
8.3	310	9.6	1.6	475	1/5	300	220	34B3BEBL-E4	—	N3575	—	N3375
14	350	9.6	1.6	475	1/5	180	200	34B3BEBL-FX4	—	N3574	—	3374
21	350	9.6	1.6	475	1/5	120	195	34B3BEBL-E4	—	N3573	—	3373
42	270	12	2.0	421	1/4	60	240	34B4BEBL-E3	N3685	3585	N3485	3385
83	245	—	2.6	475	3/8	30	250	34B6BEBL-F3	—	—	—	N3372
83	135	12	2.0	318	1/4	30	300	34B4BEBL-E3	N3683	N3583	3483	3383
125	163	—	2.6	333	3/8	20	290	34B6BEBL-F3	—	—	—	N3371
125	90	12	2.0	220	1/4	20	300	34B4BEBL-E3	N3682	N3582	3482	3382
250	82	—	2.6	166	3/8	10	300	34B6BEBL-F2	—	—	N3470	N3370
250	45	12	2.0	106	1/4	10	300	34B4BEBL-E2	N3680	N3580	N3480	3380
500	42	—	2.6	66	3/8	5	60	34B6BEBL-F1	—	—	—	3369
500	28	12	2.0	55	1/4	5	60	34B4BEBL-FX1	—	N3579	—	3379



Type 34B-E/F

INTEGRAmotor BLDC Gearmotors

Speed (rpm)	Rated Torque (lb-in.)	24V Rated Current (Amps)	Peak Torque (lb-in.)	Motor HP	Gear Ratio	Radial Load (lbs.)	Product Type	Model Number ⁴
14	341	12	475	1/4	180	200	34B4FEFL/FV-F4	N3771
42	327		421		60	240	34B4FEFL/FV-F3	N3773
63	218		350		40	240	34B4FEFL/FV-F3	3774
83	163		318		30	300	34B4FEFL/FV-F3	N3775
125	109		220		20	300	34B4FEFL/FV-F3	N3776
250	54		106		10	300	34B4FEFL/FV-F2	N3778
500	28		55		5	60	34B4FEFL/FV-F1	N3779



Type 34B/FV-F INTEGRAmotor

¹ SOA: Contact the factory for detailed speed/torque information (Safe Operating Area). See page 21; ² The fifth character of the product type changes from "B" to "F" for accessory ready models; ³ E-type only: selectively hardened all steel helical gears for long life; ⁴ Type FV INTEGRAmotors require a PWM signal from a motion controller or PLC to operate; "N" model numbers require lead time and minimum quantities. Most FX models ship within 2-5 business days. **Blue Model Numbers:** These items were upgraded to "FX" gear train and ratings. Visit our website for detailed specifications.

- Unvented gearhousing
- Flexible mounting and high torque in a compact package
- Face-mount from drive shaft side
- Models with accessory shafts are ideal for mounting encoders or brakes
- See Page 36 for capacitors and terminal boxes
- See page 40 for reference dimensions

Variable Speed—Pacesetter Inverter Duty AC Gearmotors

Fixed Speed Rating					Variable Speed (SOA) Ratings ¹						Radial Load (lbs.)	Product Type	230V Model Number
Speed (rpm)	Torque (lb-in.)	Motor HP	A	Gear Ratio	Speed Range (rpm)	Frequency Range (Hz)	Torque Type	Torque @ 10 Hz (lb-in.)	Torque @ 60 Hz (lb-in.)	Torque @ 90 Hz (lb-in.)			
Three -Phase, Inverter duty, Non-synchronous (TEFC)													
16	1,000	3/8	1.9	108	2-21	10-90	variable	896	1,000	896	350	42R6BFPP-HG	2245
30	600			56	3-41			464	776	464			N2247
38	480			45	4-51			373	623	373			N2248
63	289			27	7-85			224	368	224			2249



Type 42R-HG Pacesetter

Fixed Speed—AC Gearmotors

Speed (rpm)	Rated Torque (lb-in.)	Motor HP	V	Hz	Ph	Amps	Gear Ratio	Radial Load (lbs.)	Capacitor (μF/VAC)	Product Type	Model Number	
Permanent Split Capacitor, Non-synchronous (TEFC)												
16	599	1/5	115	60	1	2.7	108	350	30.0/250	42R6BFCL-HG	N5255	
30	310										56	5257
38	250										45	N5258
63	150										27	N5259



Type 42R-HG

Permanent Magnet DC Gearmotors

Speed (rpm)	Rated Torque (lb-in.)	Rated Current (Amps)		Motor HP	Gear Ratio	Radial Load (lbs.)	Product Type ²	Accy Shaft		No Accy Shaft	
		24V	90/130V					24V	90/130V		
24V Models With Class F Temperature Rating											
23	680	12	—	1/3	108	350	33A7BEPM-HG	N6823	N6423	—	—
45	353							6845	N6445	—	—
56	284							N6856	6456	—	—
93	170							N6893	N6493	—	—
90/130V Models With Class F Temperature Rating											
16 / 23	481 / 680	—	1.8 / 2.4	1/6 / 1/3	108	350	33A7BEPM-HG	—	—	N6323	6023
31 / 45	249 / 353				56			—	6345	N6045	
38 / 56	200 / 284				45			—	N6356	N6056	
64 / 93	120 / 170				27			—	N6393	6093	



Type 33A-HG

- Unvented gearhousing for universal horizontal mounting
- Selectively hardened steel gears for quietness and hardened steel spur gearing on subsequent stages for high output torque and long life
- Extra heavy-duty bearings and seals
- Face or base mounting
- Oversize drive shaft
- Models with accessory shafts are ideal for mounting encoders or brakes
- See Page 36 for accessories
- See page 39 for reference dimensions

Variable Speed—Pacesetter Inverter Duty AC Gearmotors

Fixed Speed Rating					Variable Speed (SOA) Ratings ¹						Radial Load (lbs.)	Product Type	230/460V Model Number
Speed (rpm)	Torque (lb-in.)	Motor HP	(230/460V) Amps	Gear Ratio	Speed Range (rpm)	Frequency Range (Hz)	Torque Type	Torque @ 10 Hz (lb-in.)	Torque @ 60 Hz (lb-in.)	Torque @ 90 Hz (lb-in.)			
Three-Phase, Inverter duty, Non-synchronous (TEFC)													
28	1000	3/4	2.7/1.3	60	2.7-38	10-90	Constant	1,000	1,000	1,000	250	48R6BFPP-CG	9360
34	850			50	3.2-46			850	850	850			9350
47	650			36	4.4-63			650	650	650			9336
57	540			30	5.3-76			540	540	540			9330
85	360	20	8.0-114	360	360	360	9320						



Type 48R-CG Pacesetter

Permanent Magnet DC Gearmotors



Type 42A-CG

Speed (rpm)	Rated Torque (lb-in.)	Rated Current (Amps)	Motor HP	Gear Ratio	Radial Load (lbs.)	Product Type ²	Accy Shaft	No Accy Shaft	Accy Shaft	No Accy Shaft
							24V		130V	
24V Models With Class F Temperature Rating										
38	660	18	7/16	60	250	42A7BEPM-CG	4886	4486	—	—
46	550			50			4885	4485	—	—
64	400			36			4884	4484	—	—
77	330			30			4883	4483	—	—
115	220			20			4882	4482	—	—
130V Models with Class F Temperature Rating										
42	580	3.3	7/16	60	250	42A7BEPM-CG	—	—	4786	4086
50	480			50			—	—	4785	4085
69	350			36			—	—	4784	4084
83	290			30			—	—	4783	4083
125	190			20			—	—	4782	4082

A/T Parallel Shaft Gearmotors | up to 120 oz-in.

- Totally enclosed, non-ventilated IP-20 rating
- Permanently lubricated, noise tested ball bearings
- Impedance protected to prevent current overload (garmotor should not be stalled when powered up)
- Capacitor is included
- Three-wire winding simplifies reversing
- See page 39 for reference dimensions

Fixed Speed—AC Gearmotors



Type K-2A/T

Speed (rpm)	Rated Torque (oz-in.)	Motor HP	V	Hz	Ph	Amps	Gear Ratio	Radial Load (oz.)	Capacitor (µF/VAC)	Product Type	Model Number				
Permanent Split Capacitor Normal Slip, Non-synchronous															
CAPACITOR IS INCLUDED															
0.9	120	1/700	115	60	1	0.07	1800	20	0.9/250	KCI-22T5	N0727				
1.9	100	1/700				0.07	900		0.9/250	KCI-22T5	0726				
5.6	95	1/700				0.07	300		0.9/250	KCI-22T4	0724				
9	95	1/700				0.07	180		0.9/250	KCI-22T4	0723				
13	95	1/450				0.083	120		1.0/250	KCI-23T4	0722				
22	95	1/300				0.11	72		1.3/250	KCI-24T4	0733				
26	80	1/300				0.11	60		1.3/250	KCI-24T3	0732				
52	34	1/450				0.083	30		1.0/250	KCI-23A2	0719				
52	59	1/300				0.11	30		1.3/250	KCI-24A2	0731				
86	21	1/450				0.083	18		1.0/250	KCI-23A2	0718				
86	35	1/300				0.11	18		1.3/250	KCI-24A2	0730				
130	24	1/300				0.11	12		1.3/250	KCI-24A2	0729				
260	12	1/300				0.11	6		1.3/250	KCI-24A2	0728				
Permanent Split Capacitor High Slip, Non-synchronous															
CAPACITOR IS INCLUDED															
0.9	120	1/1000	115	60	1	0.072	1800	20	0.9/250	KCI-22T5	N0746				
2.3	95	1/1000				0.072	600		0.9/250	KCI-22T5	0744				
4.9	95	1/1000				0.072	300		0.9/250	KCI-22T4	0743				
10	88	1/800				0.083	120		1.0/250	KCI-23T4	0741				
20	80	1/450				0.1	60		1.2/250	KCI-24T3	0750				
40	44	1/450				0.1	30		1.2/250	KCI-24A2	0749				
67	16	1/800				0.083	18		1.0/250	KCI-23A2	0737				
67	27	1/450				0.1	18		1.2/250	KCI-24A2	0748				
200	8.9	1/450				0.1	6		1.2/250	KCI-24A2	0747				
Permanent Split Capacitor, Synchronous															
CAPACITOR IS INCLUDED															
1	120	1/2000	115	60	1	0.069	1800	20	0.9/250	KYC-22T5	N0767				
2	100	1/2000				0.069	900		0.9/250	KYC-22T5	N0766				
3	88	1/2000				0.069	600		0.9/250	KYC-22T5	0765				
10	72	1/900				0.093	180		1.3/250	KYC-24T4	0776				
15	20	1/2000				0.069	120		.09/250	KYC-22T4	N0762				
15	48	1/900				0.093	120		1.3/250	KYC-24T4	N0775				
25	29	1/900				0.093	72		1.3/250	KYC-24T4	0774				
60	15	1/900				0.093	30		1.3/250	KYC-24A2	0772				
100	8.9	1/900				0.093	18		1.3/250	KYC-24A2	0771				

- Unvented gearhousing for universal horizontal mounting
- Permanently lubricated with high-performance lubricant
- Bronze gear for high shock load capability
- Hardened and ground worm for high strength and long life
- Models with accessory shafts are ideal for mounting encoders or brakes
- See Page 36 for capacitors and accessories
- See pages 41 and 42 for reference dimensions

Variable Speed – Pacesetter Inverter Duty AC Gearmotors

Fixed Speed Rating					Variable Speed (SOA) Ratings ¹						Product Type	230V Model Number
Speed (rpm)	Torque (lb-in.)	Motor HP	A	Gear Ratio	Speed Range (rpm)	Frequency Range (Hz)	Torque Type	Torque @ 10 Hz (lb-in.)	Torque @ 60 Hz (lb-in.)	Torque @ 90 Hz (lb-in.)		
28	37	1/17	0.48	60	2.2-36	10-90	constant	37	37	37	30R4BEP-3N	N2290
34	36			50	2.7-43		variable	33	37	37		N2292
43	37			40	3.3-54		constant	37	37	37		N2293
85	25			20	6.6-108		variable	24	36	36		2294
170	14			10	13-216		variable	16	28	22		N2296
340	8			5	27-431		variable	9	15	12		N2297

Three-Phase, Inverter Duty, Non-synchronous Motor (TENV)



Type 30R-3N Pacesetter

Fixed Speed – AC Gearmotors

Speed (rpm)	Rated Torque (lb-in.)	Motor HP	V	Hz	Ph	Amps	Gear Ratio	Radial Load (lbs.)	Capacitor (µF/VAC)	Product Type	Model Number
28	37	1/15	115	60	1	1.0	60	40	10.0/250	34R4BFCI-3F	0492
43	37						40	40			0491
57	30						30	40			0487
85	27						20	40			0490
113	20						15	5			0489
170	16						10	5			0488

Permanent Split Capacitor, Non-synchronous

CAPACITOR IS REQUIRED



Type 34R-3F

Permanent Magnet DC Gearmotors

Speed (rpm)	Rated Torque (lb-in.)	Rated Current (Amps)		Peak Torque (lb-in.)	Motor HP	FF	Gear Ratio	Radial Load (lbs.)	Product Type ²	Accy Shaft	No Accy Shaft	Accy Shaft	No Accy Shaft
		24V	130V							24V	130V		
42	22	2.6	0.48	46	1/17	1.0	60	40	24A4BEP-3F	N4899	N4699	N4099	0099
63	19			46			40	40		40	0098		
125	16			32			5	5		5	0096		
250	10			20			5	5		5	0094		
500	5.2			10			5	5		5	0093		
				—			—	—		—	N0089		
63	19	0.48	1/17	46	1.0	60	40	24A4BEP-3F	—	—	—	0088	
125	16			46		40	40		—	—	—	0087	
250	10			32		5	5		—	—	—	0086	
500	5.2			20		5	5		—	—	—	0084	
				10		5	5		—	—	—	N0084	

Mounting From Base Of Gearhead



Type 24A-3F (Mounting from base of gearhead)

Mounting From Base Of Motor



Type 24A-3F (Mounting from base of motor)

Hollow Shaft

24 V Models With Class F Temperature Rating

250	14	3.7	—	20	1/13	—	10	60	24A4BEP-3F/H	—	N7694	—	—
500	6.8		—	10		—	5	70		N7893	—	—	—

90 V/130 V Models With Class F Temperature Rating

29/42	35 / 37	0.56 / 0.81	1/23 / 1/11	46	1.4 / 1.0	60	100	24A4BEP-3F/H	—	—	—	7099
43/63	29 / 37			46		90	—		—	—	7098	
86/125	18 / 26			32		80	—		—	—	7096	
173/250	10 / 16			20		70	—		—	—	7094	
345/500	5.5 / 8.2			10		60	—		—	—	7093	
				—		—	—		—	—	—	



Type 24A-3F/H Hollow Shaft

¹ SOA: Contact the factory for detailed speed/torque information (Safe Operating Area). See page 21; ² The fifth character of the product type changes from "B" to "F" for accessory ready models; ³ E-type only; selectively hardened all steel helical gears for long life; ⁴ Type FV INTEGRAmotors require a PWM signal from a motion controller or PLC to operate; "N" model numbers require lead time and minimum quantities. Most FX models ship within 2-5 business days.

Brushless DC Gearmotors



Type 22B-3N

Speed (rpm)	Rated Torque (lb-in.)	Rated Current (Amps)		Peak Torque (lb-in.)	Motor HP	Gear Ratio	Radial Load (lbs.)	Product Type ²	Accy Shaft	No Accy Shaft	Accy Shaft	No Accy Shaft		
		24V	130V						24V	130V				
42	37	5.9	1.0	147	1/8	60	100	22B4BEBL-3N	N3665	3565	N3421	N3321		
62	37			123					40	90	N3666	N3566	N3422	3322
125	35			74					20	80	3667	N3567	N3423	N3323
250	22			46					10	70	N3668	N3568	3424	N3324
500	11			23					5	60	N3669	N3569	N3425	3325

INTEGRAMotor BLDC Gearmotors



Type 22B/SR-3N
INTEGRAMotor

Motor Output				Control Input			Product Type ²	Model Number	
Speed Range (rpm)		Torque (lb-in.)	Gear Ratio	Motor HP	Volts (VDC)	Continuous Amps		Type SR	Type FV
Type SR	Type FV							Analog Interface	Digital Interface ³
3-42	1.3-42	37	60	1/8	24	5.9	22B4BEBL/**-3N	N3865	N3765
5-62	2-62	37	40					3866	N3766
10-125	4-125	35	20					N3867	N3767
20-250	7.5-250	22	10					3868	N3768
40-500	15-500	11	5					N3869	N3769

Hollow Shaft



Type 22B/SR-3F/H
INTEGRAMotor
Hollow Shaft

3-42	1.3-42	37	60	1/8	24	5.9	22B4BEBL/**-3F/H	N8865	N8765
5-62	2-62	37	40					N8866	N8766
10-125	4-125	35	20					N8867	N8767
20-250	7.5-250	22	10					N8868	N8768
40-500	15-500	11	5					N8869	N8769

- Unvented gearhousing for universal horizontal mounting
- Permanently lubricated with high-performance lubricant
- Bronze gear for high shock load capability
- Hardened and ground worm for high strength and long life
- See Page 36 for capacitors and terminal boxes
- See page 42 for reference dimensions

Fixed Speed—AC Gearmotors



Type 34R-5R



Type 42R-5L

Speed (rpm)	Rated Torque (lb-in.)	Motor HP	V	Hz	Ph	Amps	Gear Ratio	Radial Load (lbs.)	Capacitor (μF/VAC)	Product Type	Model Number
34R-5R Permanent Split Capacitor, Non-synchronous, Class B Temperature Rating (TEFC)										CAPACITOR IS REQUIRED	
28	33	1/15	115	60	1	1.0	60	50	10.0/250	34R4BFCI-5R	0469
43	49						40	50			0468
85	32						20	50			0466
170	18						10	30			0465
42R-5L Permanent Split Capacitor, Non-synchronous, Class B Temperature Rating (TEFC)										CAPACITOR IS REQUIRED	
43	77	1/8	115	60	1	1.7	40	80	12.5/250	42R4BFCI-5L	0627
57	75						30	80			0626
85	54						20	80			0624
170	31						10	10			0623
42R4-5L Split Phase, Non-synchronous, Class B Temperature Rating (TEFC)											
43	77	1/8	115	60	1	3.0	40	80	—	42R4BFSI-5L	0620
57	75						30	80			0619
85	54						20	80			0618
170	31						10	10			0617

Permanent Magnet DC Gearmotors

Speed (rpm)	Rated Torque (lb-in.)	130V Rated Current (Amps)	Peak Torque (lb-in.)	Motor HP	FF	Gear Ratio	Radial Load (lbs.)	Product Type	Model Number
33A-5R 130V Models With Class B Temperature Rating, Grease Lubrication									
50	45	0.71	118	1/12	1.0	40	80	33A3BEPM-5R	6128
67	41		83			30	80		6127
100	29		44			20	80		6126
200	17		23			10	80		6125
33A-5L 130V Models With Class F Temperature Rating, Oil Lubrication									
50	77	1.4	179	1/6	1.0	40	80	33A5BEPM-5L	6119
67	75		169			30	80		6118
100	63		159			20	80		6117
200	37		91			10	80		6116
42A-5L 130V Models With Class F Temperature Rating, Oil Lubrication									
33	117	1.3	185	1/6	1.0	60	80	42A4BEPM-5L	N4120
50	77		177			40	80		4119
67	75		169			30	80		4118
100	63		159			20	80		4117
200	37		91			10	80		4116



Type 33A-5R



Type 42A-5L

up to 121 lb-in. | Right Angle Gearmotors

5N/5L

- *Type 5N only:* Needle bearings on driveshaft for high radial load capacity and long life
- *Type 5L/H only:* Ball bearings for high radial load and long life
- Unvented gearhousing for universal horizontal mounting
- Bronze worm gear for high shock load capability
- Hardened and ground worm for strength and long life
- See Page 36 for capacitors and terminal boxes
- See pages 42 and 44 for reference dimensions

Variable Speed—Pacesetter Inverter Duty AC Gearmotors

Fixed Speed Rating						Variable Speed (SOA) Ratings ¹						Product Type	230V Model No.	230/460V Model No.	
Speed (rpm)	Torque (lb-in.)	HP	(230V) A	(230/460V) A	Gear Ratio	Speed Range (rpm)	Frequency Range (Hz)	Torque Type	Torque @ 10 Hz (lb-in.)	Torque @ 60 Hz (lb-in.)	Torque @ 90 Hz (lb-in.)				
42R-5N Gearmotor															
<i>Three-Phase, Inverter Duty, Non-synchronous (TEFC)</i>															
23	121	3/8	1.90	1.90/0.95	75	2.4-31	10-90	constant	116	116	116	42R6BFPP-5N	2270	2870	
43	113					40		4.4-57	constant	109	109		109	2271	2871
57	109					30		5.9-77	constant	104	104		104	N2275	2875
85	103					20		8.9-115	constant	98	98		98	2272	2872
170	101					10		18-229	variable	66	105		101	2273	2873
340	54					5		35-458	variable	38	68		59	2274	2874
42R-5L/H Hollow Shaft Gearmotor															
<i>Three-Phase, Inverter Duty, Non-Synchronous (TEFC)</i>															
23	121	3/8	1.90	1.90/0.95	75	2.4-31	10-90	variable	121	121	116	42R6BFPP-5L/H	N2470	N2670	
43	113					40		4.4-57	constant	109	109		109	N2471	N2671
57	109					30		5.9-77	constant	104	104		104	N2475	N2675
85	103					20		8.9-115	constant	98	98		98	2472	N2676
170	101					10		18-229	variable	66	105		101	N2473	N2673
340	54					5		35-458	variable	38	68		59	N2474	N2674



Type 42R-5N Pacesetter



Type 42R-5L/H

¹ SOA: Contact the factory for detailed speed/torque information (Safe Operating Area). See page 21; ² The fifth character of the product type changes from "B" to "F" for accessory ready models; ³ Type FV INTEGRMotors require a PWM signal from a motion controller or PLC to operate; "N" model numbers require lead time and minimum quantities.

Fixed Speed—AC Gearmotors



Type 42R-5N

Speed (rpm)	Rated Torque (lb-in.)	Motor HP	V	Hz	Ph	Amps	Gear Ratio	Radial Load (lbs.)	Capacitor (µF/VAC)	Product Type	Model Number
Permanent Split Capacitor, Non-synchronous CAPACITOR IS REQUIRED											
38	113	1/6	115	60	1	2.1	40	180	15.0/350	42R5BFCI-5N	0678
75	81						20				0677
150	47						10				0672
300	25						5				0670
Split Phase (with centrifugal switch), Non-synchronous											
43	113	1/6	115	60	1	3.6	40	180	—	42R5BFSI-5N	0648
85	75						20		0647		
170	43						10		0646		
340	23						5		0645		
Three-phase, Non-synchronous											
43	113	1/4	230	60	3	1.3	40	180	—	42R5BFPP-5N	0634
85	103						20		0633		
170	67						10		0630		
340	36						5		0629		

Permanent Magnet DC Gearmotors



Type 42A-5N

Speed (rpm)	Rated Torque (lb-in.)	Rated Current (Amps)		Peak Torque (lb-in.)	Motor HP	FF	Gear Ratio	Radial Load (lbs.)	Product Type ²	Accy Shaft	No Accy Shaft	Accy Shaft	No Accy Shaft
		12/24V	90/130V							12/24V		90/130V	
42A-5N Gearmotor													
12/24V Models With Class F Temperature Rating													
25/62	109	—	177	3/16 / 7/16	1.0	1.0	40	120	42A5FEPM-5N	5838	5738	—	—
33/83	104	—	169				30			5837	5737	—	—
50/125	98	—	159				20			5836	5736	—	—
100/250	80	—	91				10			5835	5735	—	—
200/500	43	—	49	5	5834	5734	—	—					
90/130V Models With Class F Temperature Rating													
45/62	109	—	177	3/16 / 1/4	1.4 / 1.0	1.4 / 1.0	40	120	42A5BEPM-5N	—	—	4538	4138
60/83	104	—	169				30			—	—	4537	4137
90/125	83	1.9/1.8	159				20			—	—	4536	4136
180/250	44	—	91				10			—	—	4535	4135
360/500	24	—	49	5	—	—	4534	4134					



Type 33A-5L/H Hollow Shaft

33A-5L/H Hollow Shaft Gearmotor													
90/130V Models With Class F Temperature Rating													
43 / 62	84 / 109	—	177	1/8 / 1/4	1.4 / 1.0	1.4 / 1.0	40	120	33A5BEPM-5L/H	—	—	—	N6738
58 / 83	75 / 100	—	169				30			—	—	N6737	
86 / 125	54 / 78	1.4 / 1.8	159				20			—	—	N6736	
173 / 250	31 / 42	—	91				10			—	—	6735	
345 / 500	17 / 22	—	49	5	—	—	N6734						

SCR Rated—Permanent Magnet DC Gearmotors



Type 33A-5L/H / SCR Rated

90V and 180VDC gearmotors with a maximum rated armature speed of 2500 rpm.

Speed (rpm)	Rated Torque (lb-in.)	Rated Current (Amps)		Form Factor		Motor HP		Gear Ratio	Peak Torque (lb-in.)	Radial Load (lbs.)	Product Type	Model Number	
		90V	180V	90V	180V	90V	180V					90V	180V
33	89	1.6	0.8	1.4	1.4	1/7	1/7	75	190	120	33A5BEPM-5L/H	1526	1516
63	68							40	177	120	33A5BEPM-5L/H	1525	1515
83	61							30	169	120	33A5BEPM-5L/H	1524	1514
125	47							20	159	120	33A5BEPM-5L/H	1523	1513
250	25							10	91	120	33A5BEPM-5L/H	1522	1512
500	14							5	49	120	33A5BEPM-5L/H	1521	1511

SCR Rated Permanent Magnet DC Gearmotors

We define “SCR Rated” as a permanent magnet DC gearmotor that is designed to operate with an unfiltered SCR speed control while delivering similar speed and torque performance as a PMDC gearmotor that is designed to be operated from a filtered DC speed control or from a PWM speed control. SCR rated PMDC gearmotors or motors are designed to remain within their safe operating temperature range while delivering full rated torque over the entire speed range (when operated with an unfiltered SCR speed control). This is in contrast to PWM-rated PMDC gearmotors or motors which would need to be operated at reduced torque if they were operated with an unfiltered SCR speed control.

Brushless DC Gearmotors

Speed (rpm)	Rated Torque (lb-in.)	Rated Current (Amps)		Peak Torque (lb-in.)	Motor HP	Gear Ratio	Radial Load (lbs.)	Product Type ²	Accy Shaft	No Accy Shaft	Accy Shaft	No Accy Shaft
		24V	130V						24V		130V	
34B-5N Right Angle Gearmotor												
62	109	—	2.7	174	3/8	40	220	34B6BEBL-5N	—	—	—	N3396
62	79	12	2.0	174	1/4	40	230	34B4BEBL-5N	N3691	N3591	N3491	N3391
62	74	9.6	1.5	174	1/5	40	230	34B3BEBL-5N	—	N3586	—	3386
83	104	—	2.6	166	3/8	30	210	34B6BEBL-5N	—	—	—	N3397
83	75	12	2.0	166	1/4	30	210	34B4BEBL-5N	N3692	N3592	N3492	N3392
83	70	9.6	1.6	166	1/5	30	210	34B3BEBL-5N	—	N3587	—	N3387
125	98	—	2.6	156	3/8	20	180	34B6BEBL-5N	—	—	—	N3398
125	75	12	2.0	156	1/4	20	180	34B4BEBL-5N	N3693	N3593	3493	N3393
125	59	9.6	1.5	156	1/5	20	180	34B3BEBL-5N	—	N3588	—	N3388
250	64	—	2.7	161	3/8	10	140	34B6BEBL-5N	—	—	—	3399
250	42	12	2.0	161	1/4	10	140	34B4BEBL-5N	N3694	N3594	N3494	N3394
250	33	9.6	1.6	140	1/5	10	150	34B3BEBL-5N	—	N3589	—	N3389
500	36	—	2.6	142	3/8	5	120	34B6BEBL-5N	—	—	—	N3378
500	24	12	2.0	94	1/4	5	120	34B4BEBL-5N	N3695	N3595	N3495	N3395
500	18.6	9.6	1.6	74	1/5	5	120	34B3BEBL-5N	—	N3590	—	N3390



Type 34B-5N

INTEGRAmotor BLDC Gearmotors

Speed (rpm)	Rated Torque (lb-in.)	24V Rated Current (Amps)	Peak Torque (lb-in.)	Motor HP	Gear Ratio	Radial Load (lbs.)	Product Type	Model Number ³
63	104	12	—	1/4	40	230	34B4FEBL/FV-5N	N3780
83	95		—		30	210	34B4FEBL/FV-5N	N3781
125	73		—		20	180	34B4BEBL/FV-5N	N3782
250	44		—		10	140	34B4BEBL/FV-5N	3783
500	24		—		5	120	34B4BEBL/FV-5N	N3784



Type 34B/FV-5N
INTEGRAmotor

up to 121 lb-in. | Right Angle Gearmotors

5F

- Unvented gearhousing for universal horizontal mounting
- Bronze worm gear for high shock load capability
- Hardened and ground worm for strength and long life
- Models with accessory shafts are ideal for mounting encoders or brakes
- See Page 36 for capacitors and terminal boxes
- See page 42 for reference dimensions

Fixed Speed – AC Gearmotors

Speed (rpm)	Rated Torque (lb-in.)	Motor HP	V	Hz	Ph	Amps	Gear Ratio	Radial Load (lbs.)	Capacitor (µF/VAC)	Product Type	Model Number
Permanent Split Capacitor, Non-synchronous											
19 / 23	121 / 102	1/9	115	50 / 60	1	1.8 / 1.4	75	80	12.5 / 250	34R6BFCL-5F	0524
23 / 28	111 / 93						60				N0523
28 / 34	104 / 87						50				N0522
35 / 43	93 / 78						40				0521
47 / 57	83 / 70						30				N0519
70 / 85	60 / 50						20				0518
93 / 113	49 / 41						15				N0514
140 / 170	35 / 29						10				0513
280 / 340	19 / 16						5				N0511



Type 34R-5F

Permanent Magnet DC Gearmotors

Speed (rpm)	Rated Torque (lb-in.)	Rated Current (Amps)		Peak Torque (lb-in.)	Motor HP	FF	Gear Ratio	Radial Load (lbs.)	Product Type ²	Accy Shaft	No Accy Shaft	Accy Shaft	No Accy Shaft
		24V	130V							24V		130V	
62	55	5.3	0.91	118	1/8	1.0	40	80	33A5BEPM-5F	N6824	N6124	N6544	6144
125	38			83			20			N6825	N6115	6542	6142
250	21			44			10			N6822	N6122	N6541	6141
500	11			23			5			N6820	N6121	N6540	6140



Type 33A-5F

These models feature sleeve bearings on the driveshaft.

¹ SOA: Contact the factory for detailed speed/torque information (Safe Operating Area). See page 21; ² The fifth character of the product type changes from "B" to "F" for accessory ready models; ³ Type FV INTEGRAmotors require a PWM signal from a motion controller or PLC to operate; "N" model numbers require lead time and minimum quantities.

3RD Right Angle Gearmotors | up to 148 lb-in.

- Unvented gearhousing for universal horizontal mounting
- Hardened worm gears
- Face-mount on the drive-shaft side, or bottom-mount is standard
- *42A-5H only*: Single and double shaft configurations available
- See Page 36 for capacitors and terminal boxes
- See page 43 for reference dimensions

Variable Speed—Pacesetter Inverter Duty AC Gearmotors



Speed (rpm)	Fixed Speed Rating				Variable Speed (SOA) Ratings ¹						Product Type	230V Model Number
	Torque (lb-in.)	Motor HP	A	Gear Ratio	Speed Range (rpm)	Frequency Range (Hz)	Torque Type	Torque @ 10 Hz (lb-in.)	Torque @ 60 Hz (lb-in.)	Torque @ 90 Hz (lb-in.)		
0.5	95	1/25	0.38	3600	0.1-0.6	10-90	Constant	95	95	95	30R2BEPP-3RD	N8036
1.2	126	1/25	0.38	1400	0.2-1.5			121	121	121	30R2BEPP-3RD	N8014
2.8	148	1/17	0.48	600	0.2-3.6			148	148	148	30R4BEPP-3RD	8006
5.7	146	1/17	0.48	300	0.4-7.2			146	146	146	30R4BEPP-3RD	N8003
8.5	141	1/17	0.48	200	0.7-0.11			141	141	141	30R4BEPP-3RD	N8002

Fixed Speed—AC Gearmotors



Speed (rpm)	Rated Torque (lb-in.)	Motor HP	V	Hz	Ph	Amps	Gear Ratio	Radial Load (lbs.)	Capacitor (µF/VAC)	Product Type	Model Number
Permanent Split Capacitor, Non-synchronous											
CAPACITOR IS REQUIRED											
0.4	95	1/30	115	60	1	0.5	3600	160	5.0/250	30R2BEPI-3RD	N8536
1.1	126	1/30				0.5	1400		5.0/250	30R2BEPI-3RD	N8514
2.6	148	1/27				0.49	600		9.0/250	30R4BEPI-3RD	N8506
5.2	101	1/27				0.49	300		9.0/250	30R4BEPI-3RD	N8503
7.8	88	1/27				0.49	200		9.0/250	30R4BEPI-3RD	N8502

Permanent Magnet DC Gearmotors



Speed (rpm)	Rated Torque (lb-in.)	24V Rated Current (A)	130V Rated Current (A)	Motor HP	FF	Gear Ratio	Radial Load (lbs.)	Product Type ²	24V Model Number	130V Model Number
0.7	95	1.8	—	1/25	1.0	3600	160	24A2BEPM-3RD	N4336	—
0.7	95	—	0.3	1/29		3600		24A2BEPM-3RD	—	N4036
1.8	126	1.8	—	1/25		1400		24A2BEPM-3RD	N4314	—
1.8	126	—	0.3	1/29		1400		24A2BEPM-3RD	—	N4014
4.2	147	2.6	0.48	1/17		600		24A4BEPM-3RD	N4306	N4006
8.3	108	2.6	0.48	1/17	300	24A4BEPM-3RD	N4303	4003		
12.5	92	2.6	0.48	1/17	200	24A4BEPM-3RD	N4302	N4002		

Brushless DC Gearmotors



Speed (rpm)	Rated Torque (lb-in.)	24V Rated Current	130V Rated Current	Motor HP	Gear Ratio	Radial Load (lbs.)	Product Type ²	24V Model Number	130V Model Number
0.7	95	2.8	0.48	1/16	3600	160	22B2BEPL-3RD	N5336	N5036
1.8	126	2.8	0.48	1/16	1400		22B2BEPL-3RD	5314	N5014
4.2	147	2.8	0.48	1/16	600		22B2BEPL-3RD	N5306	N5006
8.3	144	5.9	0.89	1/8	300		22B4BEPL-3RD	N5303	N5003
12.5	140	5.9	0.89	1/8	200		22B4BEPL-3RD	N5302	N5002

5H Right Angle Gearmotors | up to 296 lb-in.

Variable Speed—Pacesetter Inverter Duty AC Gearmotors



Speed (rpm)	Fixed Speed Rating				Variable Speed (SOA) Ratings ¹						Product Type	230/460V Model Number
	Torque (lb-in.)	Motor HP	(230/460V) Amps	Gear Ratio	Speed Range (rpm)	Frequency Range (Hz)	Torque Type	Torque @ 10 Hz (lb-in.)	Torque @ 60 Hz (lb-in.)	Torque @ 90 Hz (lb-in.)		
Three-Phase, Inverter Duty, Non-synchronous (TEFC)												
35	296	3/4	2.7/1.3	48	3.3-48	10-90	constant	272	272	272	48R6BFPP-5H	N2280
47	285			36	4.4-63		constant	262	262	262		N2281
94	256			18	8.9-127		constant	234	234	234		N2282
170	178			10	16-228		variable	152	210	180		N2283

Permanent Magnet DC Gearmotors



Speed (rpm)	Rated Torque (lb-in.)	Rated Current (Amps)		Peak Torque (lb-in.)	Motor HP	FF	Gear Ratio	Radial Load (lbs.)	Product Type ²	Accy Shaft		No Accy Shaft	
		24V	130V							24V	130V		
Single Shaft Gearmotor, Class B													
52	189	12	2.3	340	1/3	1.0	48	150	42A7BEPM-5H	N4829	N4729	N4599	4199
69	151			316			36			N4828	N4728	N4598	4198
139	87			186			18			N4827	N4727	N4596	N4196
250	52			104			10			N4826	N4726	N4594	4194
Double Shaft Gearmotor, Class F													
52	264	15	3.3	340	1/2	1.0	48	150*	42A7BEPM-5H	N4833	N4733	N4503	N4103
69	218			340			36	150*		N4832	N4732	N4502	4102
139	129			286			18	150*		N4831	N4731	N4501	4101
250	71			158			10	150*		4830	N4730	N4500	N4100

*only on one of the two shafts

- Unvented gearhousing for universal horizontal mounting
- Hardened helical output gearing
- Bronze worm gear for high shock load capability
- Hardened and ground worm hobbled on the motor shaft for high strength and long life
- Models with accessory shafts are ideal for mounting encoders or brakes
- See Page 36 for capacitors and terminal boxes
- See pages 43 and 44 for reference dimensions

Variable Speed—Pacesetter Inverter Duty AC Gearmotors

Fixed Speed Rating						Variable Speed (SOA) Ratings ¹						Product Type	230V Model No.	230/460V Model No.
Speed (rpm)	Torque (lb-in.)	HP	(230V) A	(230/460V) A	Gear Ratio	Speed Range (rpm)	Frequency Range (Hz)	Torque Type	Torque @ 10 Hz (lb-in.)	Torque @ 60 Hz (lb-in.)	Torque @ 90 Hz (lb-in.)			
Three-Phase, Inverter Duty, Non-synchronous (TEFC)														
6	380				280	0.6-8.2			380	380	380	42R6BFPP-GB	N2236	—
14	290	3/8	1.9	—	120	1.5-19	10-90	constant	290	290	290		N2237	—
28	230				60	3.0-38			230	230	230		N2238	—
Hollow Shaft														
6	380				280	0.6-8.2			380	380	380	42R6BFPP-GB/H	2336	N2636
14	290	3/8	1.9	1.90/0.95	120	1.5-19	10-90	constant	290	290	290		N2337	N2637
28	230				60	3.0-38			230	230	230		N2338	N2639



Type 42R-GB and 42R-GB/H Hollow Shaft (Pacesetter)

Fixed Speed—AC Gearmotors

Speed (rpm)	Rated Torque (lb-in.)	Motor HP	V	Hz	Ph	Amps	Gear Ratio	Radial Load (lbs.)	Capacitor (µF/VAC)	Product Type	Model Number
Permanent Split Capacitor, Non-synchronous											
CAPACITOR IS REQUIRED											
5.9	380						280				5266
8.9	375						190				N5264
14	290	1/6	115	60	1	2.0	120	200	25.0/370	42R5BFCI-GB	5262
21	278						80				N5261
28	209						60				5260
Three-phase, Non-synchronous											
5.9	380						280				N5276
8.9	375						190				N5274
14	290	1/4	230/460	60	3	1.2/0.6	120	200	—	42R5BFPP-GB	N5272
21	307						80				N5271
28	230						60				N5270
Permanent Split Capacitor, Non-synchronous Hollow Shaft											
CAPACITOR IS REQUIRED											
5.9	380						280				N8266
8.9	375	1/6	115	60	1	2.0	190	200	25.0/370	42R5BFCI-GB/H	N8264
14	290						120				N8262



Type 42R-GB and 42R-GB/H Hollow Shaft

Permanent Magnet DC Gearmotors

Speed (rpm)	Rated Torque (lb-in.)	Rated Current (Amps)		Peak Torque (lb-in.)	Motor HP	FF	Gear Ratio	Radial Load (lbs.)	Product Type ²	Accy Shaft		No Accy Shaft	
		24V	90/130V							24V	90/130V		
33A-GB 90/130V Models With Class F Temperature Rating													
6.2 / 8.9	380 / 380			600			280						6066
9.1 / 13	358 / 375			600	1/8 / 1/4	1.4 / 1.0	190	200	33A5BEPM-GB				6064
14 / 21	251 / 290			464			120						6062
29 / 42	151 / 200			368			60						6060
90/130V Hollow Shaft													
6.2 / 8.9	380 / 380			600			280						7066
9.1 / 13	358 / 375			600	1/8 / 1/4	1.4 / 1.0	190	200	33A5BEPM-GB/H				7064
14 / 21	251 / 290			464			120						7062
29 / 42	151 / 200			368			60						7060
42A-GB 130 V Models With Class B Temperature Rating													
										24V		130V Only	
8.9	380			600			280		42A5BEPM-GB	N4866	N4766	N4466	4066
13	375			600	1/4	1.0	190	200		N4864	N4764	N4464	4064
21	290	8.8	1.8	464			120			N4862	N4762	N4462	4062
42	213			368			60			N4860	N4760	N4460	4060



Type 33A-GB



Type 33A-GB/H Hollow Shaft



Type 42A-GB

¹ SOA: Contact the factory for detailed speed/torque information (Safe Operating Area). See page 21; ² The fifth character of the product type changes from "B" to "F" for accessory ready models; "N" model numbers require lead time and minimum quantities.

Save Time, Space and Money with Hollow Shaft Gearmotors

Hollow shaft gearmotors connect directly to the driven load, reducing the overall space required by the gearmotor and eliminating expensive shaft couplings, mounting hardware, chains and sprockets. Hollow shaft flange mounting can also eliminate the need for a support bearing on one side of a conveyor roller.

Motors without Gearing

Bodine offers a full range of fractional horsepower motors.

AC fixed and variable speed motors are available with voltage ratings of 115 VAC, 60 Hz (single-phase), 230 VAC, 60 Hz (3-phase) and 230/460 VAC, 60 Hz (3-phase). They are offered with three winding types: permanent split capacitor, split phase, and three-phase. **PMDC motors** are available with voltage ratings from 12 to 180 VDC. **Brushless DC motors** are available with voltage ratings of 24 or 130 VDC.



AC Torque Motors | from 3.5 to 68 oz.in.

- Will operate satisfactorily on 50 or 60 Hz
- Totally enclosed non-ventilated IP-20 rating
- Provides excellent performance for holding, winding and tensioning applications
- Provides locked rotor or reverse torque intermittently at rated voltage, or continuously at reduced voltage
- Permanently lubricated, noise tested ball bearings
- Locked bearing design on 30R, 42R, and 48R minimizes shaft endplay
- See Page 36 for capacitors and accessories
- See pages 45 and 46 for reference dimensions

AC Torque Motors (for holding applications)



V	Hz	Locked Rotor Performance				rpm @ No Load	Capacitor (µF/VAC)	Product Type	Model Number
		% Duty Cycle	Torque (oz-in.)	Watts	Max. On Time (min.)				
KCI									
CAPACITOR IS INCLUDED									
115	60	40	7.0	22	5	1580	2.3/250	KCI-26	0621
83	60	100	3.5	12	—	1570			
115	50	40	6.0	19	5	1310			
92	50	100	4.0	13	—	1300			
30R									
CAPACITOR IS REQUIRED									
115	60	50	25	52	30	1660	5.0/250	30R2FEC1	5625
100	60	100	19	40	—	1645			
115	50	50	25	47	30	1425			
100	50	100	19	36	—	1420			
42R									
CAPACITOR IS REQUIRED									
115	60	40	38	85	28	1690	7.5/370	42R6FEC1	2628
87	60	100	22	49	—	1680			
115	50	40	38	82	28	1445			
87	50	100	22	47	—	1435			
48R NEMA-56C Face Mount, Or Base Mount									
CAPACITOR IS REQUIRED									
115	60	40	65	120	15	1560	12.5/370	48R6FEC1	0632
80	60	100	32	60	—	1560			
115	50	40	68	96	15	1370			
80	50	100	34	58	—	1360			

Typical Performance Curves at 115V, 60 Hz

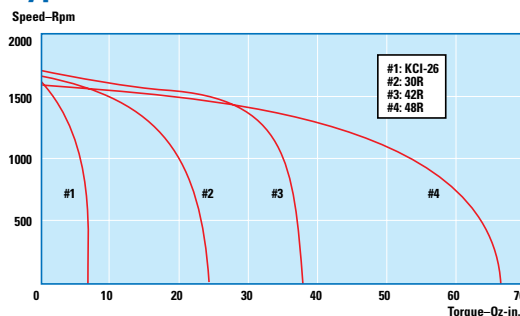

- Quinsulation™, 5-stage insulation system designed to meet NEMA MG 1-1993, Section IV, Part 31
- Most standard models are available with either 230VAC, 60Hz, 3-phase or 230/460V, 60Hz 3-phase
- Inverter-grade magnet wire and Class F insulation system for increased protection against spikes and corona damage caused by the inverter
- UL recognized for construction, CSA certified, and in compliance with the Low Voltage Directive “CE”
- See Page 36 for capacitors and terminal boxes
- See pages 45 and 46 for reference dimensions

Variable Speed— Type 30R — 1/25-1/17 HP

Fixed Speed Ratings				Variable Speed (SOA) Ratings ¹						Product Type	230V Model Number	460V Model Number
Speed (rpm)	Torque (oz-in.)	HP	Amps	Speed Range (rpm)	Frequency Range (Hz)	Torque Type	Torque @					
							10 Hz (oz-in.)	60 Hz (oz-in.)	140 Hz (oz-in.)			
1700	24	1/25	0.38	220-3150	10-140	variable	20	56	27	30R2BEPP	N2200	—
	24	1/25	0.19	215-3230			24	56	23	30R2BEPP	—	N2600
	35	1/17	0.48	133-3240			45	66	35	30R4BEPP	2201	—



Type 30R Pacesetter

Variable Speed— Type 34R — 1/8-1/4 HP

Fixed Speed Ratings					Variable Speed (SOA) Ratings ¹						Product Type	230V Model Number	230/460V Model Number
Speed (rpm)	Torque (oz-in.)	HP	(230V) Amps	(230/460V) Amps	Speed Range (rpm)	Frequency Range (Hz)	Torque Type	Torque @					
								10 Hz (oz-in.)	60 Hz (oz-in.)	Max. Hz (oz-in.)			
Three-Phase, Inverter Duty, Non-synchronous Motor (TEFC)													
1700	155	1/6	1.0	1.0/.50	120-2960	10-120	variable	80	155	95	34R4BFPP	—	N2898
1700	148	1/4	1.2	1.2/0.60	220-3650	10-140	variable	120	247	90	34R6BFPP	2295	2895
Three-Phase, Inverter Duty, Synchronous Motor (TEFC)													
1800	70	1/8	1.4	—	300-2400	10-80	variable	54	103	48	34R6BFYP	2299	—



Type 34R Pacesetter

Variable Speed— Type 42R — 3/8 HP

Fixed Speed Ratings					Variable Speed (SOA) Ratings ¹						Product Type	230V Model Number	230/460V Model Number
Speed (rpm)	Torque (oz-in.)	HP	(230V) Amps	(230/460V) Amps	Speed Range (rpm)	Frequency Range (Hz)	Torque Type	Torque @					
								10 Hz (oz-in.)	60 Hz (oz-in.)	140 Hz (oz-in.)			
Three-Phase, Inverter Duty, Non-synchronous Motor (TEFC), Base Mount													
1700	222	3/8	1.9	1.9/.95	177-3500	10-140	variable	170	281	137	42R6BFPP	2235	2835
Three-Phase, Inverter Duty, Non-synchronous Motor (TEFC), NEMA C Face Mount													
1700	222	3/8	1.9	1.9/.95	177-3500	10-140	variable	170	281	137	42R6BFPP	N2234	2834



Type 42R Pacesetter

Variable Speed— Type 48R — 1/3-3/4 HP

Fixed Speed Ratings				Variable Speed (SOA) Ratings ¹						Product Type	230/460V Model Number
Speed (rpm)	Torque (oz-in.)	HP	(230/460V) Amps	Speed Range (rpm)	Frequency Range (Hz)	Torque Type	Torque @				
							10 Hz (oz-in.)	60 Hz (oz-in.)	Max. Hz (oz-in.)		
Three-Phase, Inverter Duty, Non-synchronous Motor (TEFC), NEMA-56C Face Mount or Base Mount											
1700	445	3/4	2.7/1.3	160-3600	10-140	variable	412	675	220	48R6BFPP	2240
Three-Phase, Inverter Duty, Synchronous Motor (TEFC), NEMA-56C Face Mount or Base Mount											
1800	185	1/3	2.4/1.2	300-2400	10-80	variable	220	262	125	48R5BFYP	2244



Type 48R Pacesetter

¹ SOA: Contact the factory for detailed speed/torque information (Safe Operating Area). See page 21. “N” model numbers require lead time and minimum quantities.

Safe Operating Torque and Speed Area (SOA)

Rated Torque is either the value of torque which corresponds to nameplate output power and speed at 60 Hz, or it is the maximum torque at gear strength limits (rated torque can be either motor limited or gear-limited).

SOA Torque is defined as the maximum torque at which the motor still operates within Class F thermal limits, or as the maximum torque of a gearmotor when it is gear-limited. Continuous duty operation must be limited to the area below the

SOA or gear-limited torque curves. The SOA torque for synchronous motors is close to the pull-in torque; that is, the motor will pull out of synchronism if the required torque exceeds the SOA torque.

Examples of typical “SOA” Graphs. Contact our technical support staff for specific SOA information.

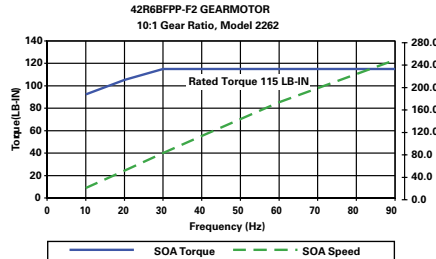
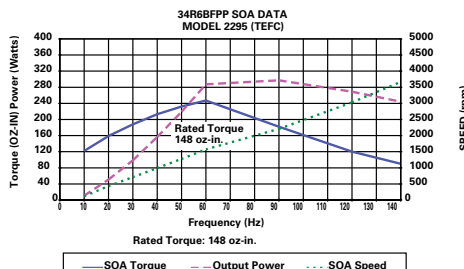

- Totally enclosed IP-20 rating
- Fan cooled for high output power
- Class B insulation system operated within Class A limits to prolong winding and lubricant life
- Locked bearing design minimizes shaft endplay
- Locked bearing design on 30R, 34R, 42R, and 48R minimizes shaft endplay
- See Page 36 for capacitors and accessories
- See pages 45 and 46 for reference dimensions

Fixed Speed—Type K-2 1/1600-1/200 HP



Type K-2

Speed (rpm)	Rated Torque (oz-in.)	HP	V	Hz	Ph	Amps	Radial Load (lbs.)	Capacitor (μF/VAC)	Product Type	Model Number
Permanent Split Capacitor, Non-synchronous CAPACITOR IS INCLUDED										
1550	1.4	1/450	115	60		0.08		1.0/250	KCI-23	0705
1550	2.2	1/300	115	60	1	0.104	5.7	1.3/250	KCI-24	0712
1550	3.2	1/200	115	60		0.124		1.6/250	KCI-26	0713
Permanent Split Capacitor, High Slip, Non-synchronous CAPACITOR IS INCLUDED										
1200	1.1	1/800	115	60	1	0.082	5.7	1.0/250	KCI-23	0707
	1.8	1/450				0.098		1.2/250	KCI-24	0714
Permanent Split Capacitor, Synchronous CAPACITOR IS INCLUDED										
1800	0.35	1/1600				0.077		1.0/250	KYC-23	0701
1800	0.62	1/900	115	60	1	0.091	5.7	1.3/250	KYC-24	0709
3600	0.31	1/900				0.102		1.6/250	KYC-24	0710

Fixed Speed—Type 30R 1/40-1/30 HP



Type 30R

Speed (rpm)	Rated Torque (oz-in.)	HP	V	Hz	Ph	Amps	Radial Load (lbs.)	Capacitor (μF/VAC)	Product Type	Model Number
Permanent Split Capacitor, Non-synchronous CAPACITOR IS REQUIRED										
1700	20					0.45	18	5.0/250		5240
3400	10	1/30	115	60	1	0.47			30R2BECI	5219
Permanent Split Capacitor, High Slip, Synchronous CAPACITOR IS REQUIRED										
1800	14	1/40	115	60	1	0.52	18	5.0/250	30R2BEYC	5246

Fixed Speed—Type 34R 1/15-1/5 HP



Type 34R

Speed (rpm)	Rated Torque (oz-in.)	HP	V	Hz	Ph	Amps	Radial Load (lbs.)	Capacitor (μF/VAC)	Product Type	Model Number
Permanent Split Capacitor, Three-Wire Reversible, Non-Synchronous CAPACITOR IS REQUIRED										
1700	85	1/7	115	60	1	1.7		27.5/250		0294
1400/1700	74	1/8	230	50/60	1	0.8/0.7	50	6.0/450	34R6BFCI	0296
Permanent Split Capacitor, Non-synchronous CAPACITOR IS REQUIRED										
1700	39	1/15				1		10.0/250	34R4BFCI	0290
1700	65	1/9	115	60	1	1.4	50	12.5/250	34R6BFCI	0291
3400	42	1/7				1.75		15.0/250	34R6BFCI	0293
Permanent Split Capacitor, Synchronous CAPACITOR IS REQUIRED										
1800	38	1/15	115	60	1	1.5	50	15.0/250	34R6BFYC	N0297
Three-phase, Non-synchronous										
1700	119	1/5	230	60	3	1.2	50	—	34R6BFPP	0295
Three-phase, Synchronous										
1800	70	1/8	230	60	3	1.4	50	—	34R6BFYP	0299

Common Abbreviations

BLDC	Brushless DC
FF	Form Factor—A measurement which indicates to what degree rectified current departs from pure DC. A higher form factor increases the heating effect of the motor and reduces brush life. ¹
IP-44	Ingress Protection Rating—Protection against sprays from all directions—limited ingress permitted. ²
NEMA-12	Enclosures (without knockouts) for indoor use. Provides a degree of protection to personnel against access to hazardous parts and to the equipment inside against ingress of solid objects, and lightly splashed liquids. ³
NEMA-4	Enclosures constructed for either indoor or outdoor use. Protects personnel against access to hazardous parts. Protects equipment inside the enclosure against ingress of solid objects and rain, sleet, snow, splashing water, and hose-directed water. ³
PMDC	Permanent magnet DC
TEFC	Totally enclosed, fan cooled
TENV	Totally enclosed, non-ventilated

1. Bodine Handbook, fifth edition. Chicago, 1993; 2. American National Standards Institute ANSI/IEC 60529-2004; 3. NEMA.org, NEMA 250-2003

Fixed Speed—Type 42R 1/12-1/4 HP

Speed (rpm)	Rated Torque (oz-in.)	HP	V	Hz	Ph	Amps	Radial Load (lbs.)	Capacitor (µF/VAC)	Product Type	Model with NEMA-C Face and Base Mount	Model with NEMA-C Face Mount	Model with Base Mount
Permanent Split Capacitor, Three-Wire Reversible, Non-Synchronous										CAPACITOR IS REQUIRED		
1700	148	1/4	115	60	1	2.9	50	45.0/250 ¹	42R6BFCI	0267	—	—
1400/1700	144/119	1/5	230	50/60	1	1.1 / 1.2	50	10.0/450	—	0268	—	—
Permanent Split Capacitor, Non-synchronous										CAPACITOR IS REQUIRED		
1700	101	1/6	115	60	1	1.9	50	15.0/350	42R5BFCI	—	0260	0258
Split phase (with centrifugal switch), Non-synchronous												
1700	48	1/12	115	60	1	2.4	50	—	42R3BFSI	—	N0261	0251
1700	101	1/6	115	60	1	3.6	50	—	42R5BFSI	—	0254	0253
3450	50	1/6	115	60	1	3.3	50	—	42R5BFSI	—	N0265	0255
Three-phase, Non-synchronous												
1700	148	1/4	230	60	3	1.2	50	—	42R5BFPP	—	N0263	0273
			230/460	60	3	1.2/0.6	50	—	—	—	N0264	0274



Type 42R
(Base Mount shown)

¹ Run capacitor 45µF/250 VAC for 60Hz operation (p/n 49401145). Use 40µF/250 VAC capacitor (p/n 49401147) for 50 Hz operation (motor derated to 1/6 HP at 50 Hz).

Fixed Speed—Type 48R 1/3-1/2 HP

Speed (rpm)	Rated Torque (oz-in.)	HP	V	Hz	Ph	Amps	Radial Load (lbs.)	Capacitor (µF/VAC)	Product Type	Model Number	
Permanent Split Capacitor, Non-synchronous										CAPACITOR IS REQUIRED	
1700	196	1/3	115	60	1	4.0/2.0	205	20.0/350	48R6BFCI	0283	
			230	60	1	4.0/2.0	205	12.5/350	—	—	
Split Phase, Non-Synchronous (With Centrifugal Switch)											
1700	196	1/3	115/230	60	1	4.8/2.4	205	—	48R6BFSI	0284	
Three-phase, Non-Synchronous											
1400	296	1/2	230	50	3	2.0	205	—	48R6BFPP	0286	
1700			230	60		1.7					
1400			460	50		1.0					
1700			460	60		0.85					
Three-phase, Synchronous											
1800	185	1/3	230/460	60	3	2.5/1.3	205	—	48R5BFYP	0281	



Type 48R
(NEMA-56C Face Mount, and/or Base Mount)

“N” model numbers require lead time and minimum quantities.

Comparative Advantages of AC Motors and Geardrives

This table illustrates some of the capabilities, advantages, and disadvantages of common AC motor and gearmotor designs.

Motor Winding	Speed Tolerance	Typical Rated Speeds at 60Hz	Start/Stop Frequency	Coast without Brake	Coast with Dynamic Braking	Starting Torque (% of Rated Torque)	Pros	Cons
Split Phase (SI)	±3%	1700-1750 (4-pole) 3450 (2-pole)	Up to 6/hour	20-600 rev.	0.5-6 rev.	175% and up	No capacitors	Switch life 50k to 250k starts
Permanent Split Capacitor (CI)	±3%	1700-1750 (4-pole) 3450 (2-pole)	Up to 10/min.	20-600 rev.	0.5-6 rev.	90-100%	Very reliable, Low starting current	Low starting torque
Three Phase (PP, Non-synchronous)	±3%	1700-1750 (4-pole) 3450 (2-pole)	Up to 10/min.	20-600 rev.	0.5-6 rev.	200-400%	Most reliable and efficient, No cap/switch	Requires three-phase power supply

Variable Speed Drive Systems

	Requires Brushes	High Torque at Speeds Above and Below Rated	Noise Level	Performance	Speed Range
Variable Speed AC	No	No	Higher	Limited	Limited
PMDC System	Yes	Yes	Highest	Good	Widest
BLDC System	No	Yes	Lowest	Best	Widest

- Totally Enclosed, Non-Ventilated (IP40)
- Class F insulation, Class B rating
- Skewed armature for smooth low speed operation
- High starting torque and self-braking
- Oversized magnets resist demagnetization, stabilized to common strength for consistent performance
- Locked bearing minimizes endplay
- Models with accessory shafts are ideal for mounting encoders or brakes
- See Page 36 for accessories
- See pages 45 and 46 for reference dimensions

PMDC Type 24A | 1/50-1/7 HP



Speed (rpm)	Rated Torque (oz-in.)	Current (Amps)	HP	FF	K _T (oz-in/A)	K _E (V/krpm)	Wdg. Res. (Ohms)	Winding Ind. (mH)	Inertia (oz-in-sec. ²)	Radial Load (lbs.)	Product Type ²	24V Winding		130V Winding			
												Accy Shaft	No Accy Shaft	Base ¹		Flange	
														No Accy Shaft	Accy Shaft	No Accy Shaft	Accy Shaft
2500	8	1.2	1/50	1.0	8.3	6.1	5.7	6.7	0.003	25	24A0BEPM	N4440	N0040	—	—	—	
2500	8	0.22	1/50		42	31	176	220	0.003		24A0BEPM	—	—	—	N4439	N0039	—
2500	16	1.8	1/29		10	7.5	2.5	3.6	0.005		24A2BEPM	N4445	0045	—	—	—	—
2500	14	0.3	1/29		55	41	84	133	0.005		24A2BEPM	—	—	0042	N4441	0041	—
2500	22	2.6	1/17		9.2	6.8	2	6.7	0.007		24A4BEPM	N4444	0044	—	—	—	—
2500	24	0.48	1/17		55	40	5	84	0.007		24A4BEPM	—	—	—	0047	0043	—
11,500	12	1.1	1/7		14	10	3.15	4.5	0.007		24A4BEPM	—	—	0049 ²	—	—	—

¹ Models 0042 and 0049 ship with a factory installed base mounting kit.

² Model 0049 rated V is 115VDC.

PMDC Type 33A | 1/16-1/3 HP



Speed (rpm)	Rated Torque (oz-in.)	Current (Amps)	HP	FF	K _T (oz-in/A)	K _E (V/krpm)	Winding Res. (Ohms)	Winding Ind. (mH)	Inertia (oz-in-sec. ²)	Radial Load (lbs.)	Product Type ²	24V Winding		130V Winding	
												Accy Shaft	No Accy Shaft	Accy Shaft	No Accy Shaft
2500	50	5.5	1/8	1.0	10.2	7.5	0.66	1.9	0.031	55	33A3BEPM	N6424	6024	—	—
	95	9.2	1/4		11.1	8.2	0.29	0.98	0.043		33A5BEPM	—	6021	—	—
	134	12	1/3		11.5	8.5	0.31	0.59	0.075		33A7BEPM	N6422	6022	—	—
90/130 V Class F Temperature Rating															
1725/2500	36/50	.78 / 1.0	1/16 / 1/8	1.4 / 1.0	56	42	22	0.57	0.031	55	33A3BEPM	—	—	6434	6034
	73/95	1.4 / 1.8	1/8 / 1/4		60	44	11	0.28	0.043		33A5BEPM	—	—	6435	6035
	97/134	1.8 / 2.4	1/6 / 1/3		66	49	8.8	0.18	0.075		33A7BEPM	—	—	—	6037
130V, Class B Temperature Rating															
2500	34	.71	1/12	1.0	54	40	23	67	0.031	55	33A3BEPM	—	—	—	6016
	50	.91	1/8		57	42	13	41	0.043		33A5BEPM	—	—	—	6020

PMDC Type 42A | 1/4-1/2 HP



Speed (rpm)	Rated Torque (oz-in.)	Current (Amps)	HP	FF	K _T (oz-in/A)	K _E (V/krpm)	Winding Res. (Ohms)	Winding Ind. (mH)	Inertia (oz-in-sec. ²)	Radial Load (lbs.)	Product Type ³	24V Winding		130V Winding	
												Accy Shaft	No Accy Shaft	Accy Shaft	No Accy Shaft
2500	101	8.8	1/4	1.0	12	9.2	0.27	0.64	0.082	90	42A5BEPM	N4421	N4021	—	—
	101	1.8	1/4		60	44	5.5	20	0.082		42A5BEPM	—	—	4435	4035
	135	12	1/3		12	9	0.16	0.45	0.12		42A7BEPM	N4422	N4022	—	—
	135	2.3	1/3		64	47	4.2	17	0.12		42A7BEPM	—	—	N4437	4037
NEMA 42CZ Face Mount, Class F Temperature Rating															
2500	150	15	1/3	1.0	11	8	0.18	0.61	0.082	90	42A5BEPM	N4800	N4601	—	—
	150	2.7	1/3		60	45	3.2	—	0.082		42A5BEPM	—	—	N4430	N4031
	180	19	1/2		11.5	8.5	0.12	0.54	0.12		42A7BEPM	N4802	N4603	—	—
	180	3.3	1/2		57	42	2.7	—	0.12		42A7BEPM	—	—	N4432	4033

³ The fifth digit of the product type changes from "B" to "F" for accessory ready models. "N" model numbers require lead time and minimum quantities.

Speed Regulation of Permanent Magnet DC Motors

In a PMDC motor, speed is proportional to voltage and torque is proportional to current. When voltage is held constant, the amount that speed drops due to increasing torque is called "speed regulation." The thin blue lines illustrate motor performance without the aid of a regulating electronic control. The heavy red lines illustrate performance from a control with "excellent" (1-3%) speed regulation.

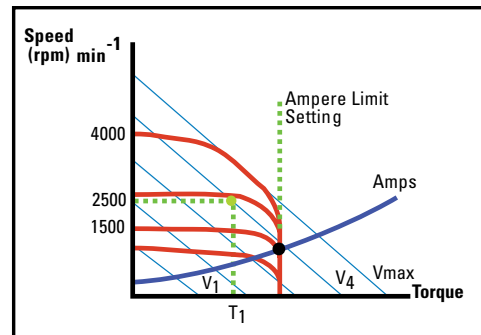

- Quiet operation, low electromagnetic interference (EMI)
- No brush maintenance or contamination from brush dust
- 60° Commutation Angle
- Wire harness differs between 24V and 130V models. Check online CAD drawings for details.
- See Page 36 for accessories
- See page 45 for reference dimensions

Brushless DC— Type 22B | 1/16-1/5 HP

Speed (rpm)	Rated Torque (oz-in.)	HP	Torque Constant (oz-in./A)	Voltage Constant (V/krpm)	Winding		Rotor Inertia (oz-in.-sec. ²)	Radial Load (lb.)	Product Type ¹	Accy Shaft	No Accy Shaft	Accy Shaft	No Accy Shaft
					Res. (Ohms)	Induct. (mH)				24V		130V	
2500	25	1/16	8.4	5.8	1.2	2.1	0.0036	25	22B2BEBL	N3602	3502	—	—
2500	25	1/16	47	35	40	70	0.0036		22B2BEBL	—	—	—	3302
2500	50	1/8	9	6.7	0.52	1.1	0.0072		22B4BEBL	3604	N3504	—	—
2500	50	1/8	63	37	15	40	0.0072		22B4BEBL	—	—	3404	3304
10,000	20	1/5	14	9.8	4.8	10	0.0072		22B4BEBL	—	—	—	3314



Type 22B

Brushless DC— Type 34B | 1/5-3/8 HP

Speed (rpm)	Rated Torque (oz-in.)	HP	Torque Constant (oz-in./A)	Voltage Constant (V/krpm)	Winding		Rotor Inertia (oz-in.-sec. ²)	Radial Load (lb.)	Product Type ¹	Accy Shaft	No Accy Shaft	Accy Shaft	No Accy Shaft
					Res. (Ohms)	Induct. (mH)				24V		130V	
2500	81	1/5	8.8	6.6	0.3	0.54	0.0115	42	34B3BEBL	3600	3500	—	—
2500	81	1/5	51	38	9.2	24	0.0115		34B3BEBL	—	—	3406	3306
2500	101	1/4	9.0	6.7	0.17	0.40	0.0154		34B4BEBL	—	N3507	—	—
2500	101	1/4	51	38	5.8	14	0.0154		34B4BEBL	—	—	—	3307
2500	151	3/8	9.0	6.7	0.099	0.246	0.0215		34B6BEBL	N3609	N3509	—	—
2500	151	3/8	57	42	3.4	11	0.0215		34B6BEBL	—	—	3409	3309
10,000	33	1/3	14.5	10.7	1.7	4.6	0.0154		34B4BEBL	—	—	—	3317



Type 34B

INTEGRAMotor BLDC— Type 22B | 1/16-1/4 HP

Motor Output		Torque Constant (oz-in./A)	Voltage Constant (V/krpm)	Winding		Rotor Inertia (oz-in.-sec. ²)	Control Input			Product Type	Model Number		
Speed Range (rpm)	Torque (oz-in.)			Res. (Ohms)	Induct. (mH)		HP	Volts (VDC)	Continuous Amps		Type SR	Type FV	
Type SR	Type FV									Analog Interface	Digital Interface ²		
22B INTEGRAMotor													
200-2500	75-2500	25	47	35	40	70	0.004	1/16	24	3.3	22B2BEBL/**	3802	N3702
		50	50	37	15	40	0.007	1/8			22B4BEBL/**	3804	3704
34B INTEGRAMotor													
—	60-2500	100	9.6	7.1	0.18	0.43	0.0154	1/4	24	12	34B4FEBL/FV	—	3708



Type 22B/SR and 22B/FV INTEGRAMotor



Type 34B/FV INTEGRAMotor

¹ The fifth character of the product type changes from "B" to "F" for accessory ready models.

² Type FV INTEGRAMotors require a PWM signal from a motion controller or PLC to operate.

** INTEGRAMotor can be ordered with either analog (/SR) or digital (/FV) interface option.

"N" model numbers require lead time and minimum quantities.

Flange mount shown

Motor Speed Controls

Our motion controls are precisely engineered to provide maximum performance from our motors and gearmotors. Choose a Bodine gearmotor and speed control and get our extended 2-year system warranty.



AC Pacesetter™ Inverter Duty Three Phase Motor Speed Controls

Basic Three-Phase Chassis AC Motor Speed Control



- Speed control via external speed pot or external 0-5 VDC analog signal (isolation required)
- Adjusts current limit, max. speed, min. speed, decel. time, accel. time, and slip compensation
- Output freq. selectable between 0-60 Hz and 0-120 Hz.
- Connector for remote direction control
- Connector for remote momentary start switch
- Protection against overload, overvoltage, undervoltage, and short circuit
- UL Listed, CE
- See page 47 for reference dimensions

Three-Phase AC Output Power				Input Power		Model Number
HP	Motor V	Motor Amps	Hz	V	Hz	
1/2	230	2.4	0-120	115	50 / 60	2982
1/2		2.4		230		2983
1/2		2.4		115 / 230		2984
1		4		115 / 230		2987

NEMA 4X/IP-65 Enclosed AC Motor Speed Control



- LED status indicators provide indication of the drive's status and operating mode
- GFCI compatible
- F-B-R (Forward-Brake-Reverse), Start/Stop, and On/Off switches
- Motor current selection
- More than 200% starting torque
- Overvoltage and undervoltage
- Run/Fault relay output contacts turn equipment on/off and signal stop mode if a fault has occurred.
- No remote operation
- cULus

Three-Phase AC Output Power				Input Power		Model Number
HP	Motor V	Motor Amps	Hz	V	Hz	
1	230	3.6	0-120	115 or 208/230	50 / 60	2999

NEMA-1/IP-40 Enclosed AC Motor Speed Control



- Run/Fault relay output contacts turn equipment on/off and signal stop mode if a fault has occurred.
- Barrier terminal blocks facilitate wiring
- Motor overload (I^2t) with RMS current limit
- Electronic inrush current limit
- Regeneration eliminates tripping due to bus overvoltage
- Overvoltage and undervoltage
- No remote operation
- Built-in line filter for CE compliance
- cULus, CE

Three-Phase AC Output Power				Input Power		Model Number
HP	Motor V	Motor Amps	Hz	V	Hz	
1	230	3.6	0-120	115 or 208/230	50 / 60	2998

Type UPM | Unfiltered SCR Motor Speed Control (NEMA-4 Enclosure)

- Operates from 115 Volt AC or 230 Volt AC line
- Designed to drive 90 Volt DC or 130 Volt DC motors
- Switchable output for 0-90 Volt DC or 0-180 Volt DC
- Back EMF feedback maintains better than 2% speed regulation
- Dip switches to easily calibrate control for different motor sizes
- NEMA 4 enclosure for wet or dirty environments
- Trim pots on PC board to adjust torque limit, minimum speed limit, maximum speed limit, acceleration time, deceleration time, and speed regulation
- Speed can be adjusted manually using speed pot on front of enclosure
- Terminal block inside enclosure for quick line and motor connection
- Line fuses inside enclosure
- Line filter inside enclosure to reduce conducted EMI
- cURus, CE, RoHS



HP Rating	Input V (VAC, 50/60 Hz)	Motor Rating (VDC)	Continuous Output Current (Amps)	Peak Output Current (Amps)	FF	Product Type	Model Number
1/5 @ 90V 1/3 @ 180V	115 / 230	90 or 130 @ 115 VAC 180 @ 230 VAC	2.1	4.2	1.4	UPM-3318E4	1865

Type WPM | Filtered PWM DC Basic Speed Control (Chassis, IP-00)

- Models 0780-0784 operate from 115 Volt AC line, 50/60 Hz
- Models 0786-0789 operate from a DC power supply or a battery
- 115V models: filtered DC output for cooler motor operation, longer brush life, lower audible noise, and wider speed range
- Back EMF feedback maintains better than 1% speed regulation
- Dip switches to easily calibrate control for different motor sizes
- Two diagnostic LEDs indicate when power is on and when current output is at limit set by TORQ pot
- Five on-board user-adjustable pots for torque limit, minimum speed limit, maximum speed limit, acceleration time, and speed regulation
- Speed can be adjusted manually using a remote 10k speed pot (included with control)
- Connections for optional user-supplied inhibit switch
- cURus, RoHS



WPM Chassis Control (115 V model with terminal block)

HP Rating	Input V (VAC, 50/60 Hz)	Motor Rating (VDC)	Continuous Output Current (Amps)	Peak Output Current (Amps)	FF	Product Type	Model Number	
							1/4 in. QC tab	Terminal Block
WPM Chassis Filtered PWM DC Control (115 V Models)								
1/4	115	90 or 130	2.0	2.5	1.0	WPM-2109C	0780	0783
7/16			3.2	5			0781	0784
WPM Chassis PWM DC Control (12 and 24 V Models)								
1/12 @1250 rpm	1/6 @2500 rpm	(VDC) 12-14	15	35	1.0	WPM-2137C	—	0787
—	1/3		24-35				17	0786
—	1/3	24	14	—	—	—	0788	0789



WPM Chassis Control (12 or 24 V models)

Type WPM | Filtered PWM DC Basic Speed Control (NEMA-1, IP-40)

- Filtered DC output
- Designed to drive 90 Volt DC or 130 Volt DC motors
- Dip switches to easily calibrate control
- Model 0794: includes F-B-R (forward-brake-reverse) switch
- Line voltage compensation minimizes speed drift
- Trim pots on PC board to adjust torque limit, minimum speed limit, maximum speed limit, acceleration time, and speed regulation
- Manual speed adjustment
- Terminal block inside enclosure
- Back EMF feedback maintains better than 2% speed regulation
- Factory installed AC line cable
- cURus, RoHS



WPM Enclosed Control (Speed only)

HP Rating	Input V (VAC, 50/60 Hz)	Motor Rating (VDC)	Continuous Output Current (Amps)	Peak Output Current (Amps)	FF	Product Type	Model Number
WPM Enclosed Filtered PWM DC Control							
1/4	115	90 or 130	2.0	2.5	1.0	WPM-2109E1	0790
7/16			3.2	5			0791
WPM Enclosed Filtered PWM DC Speed and Direction Control							
7/16 @ 90 V 5/8 @ 130 V	115	90 or 130	3.7	7.1	1.0	WPM-2148E1	0794



WPM Enclosed Control (With Direction Switch)

For control accessories see page 37. See page 47 for reference dimensions. Visit our website for 2D/3D CAD drawings.

Type FPM | Filtered SCR DC Basic Speed Control



- Designed to drive 90 Volt DC or 130 Volt DC motors
- Dip switches to easily calibrate control
- Line voltage and temperature compensation
- Trim pots on PC board to adjust torque limit, minimum speed limit, maximum speed limit, acceleration time, and speed regulation.
- Back EMF feedback maintains better than 2% speed regulation
- 10k Ohm remote speed pot and 24" connecting wire supplied with each control
- Connections for optional user-supplied inhibit switch
- Terminal block
- Plug-in connector for speed pot and optional user supplied inhibit switch
- Flexibility in adding plug-in interface boards
- Built-in line and motor fuseholders (both fuses supplied)
- UR, CSA, RoHS

HP Rating	Input V (VAC, 50/60 Hz)	Motor Rating (VDC)	Continuous Output Current (Amps)	Peak Output Current (Amps)	FF	Product Type	Model Number
1/17	115	90 or 130	0.5	1	1.0	FPM-0810C	0810
1/6			1.25	2.5		FPM-0830C	0830
1/3			2.3	4.6		FPM-0850C	0850

Type FPM | Filtered SCR DC Basic Speed Control (NEMA-12 Enclosure)



- Designed to drive 90 Volt DC or 130 Volt DC motors
- Dip switches to easily calibrate control
- Line voltage and temperature compensation
- Trim pots on PC board to adjust torque limit, minimum speed limit, maximum speed limit, acceleration time, and speed regulation.
- Manual speed adjustment
- Terminal block inside enclosure
- Back EMF feedback maintains better than 2% speed regulation.
- Fuse holders for line and motor inside enclosure (both fuses supplied)
- UR, CSA, RoHS

HP Rating	Input V (VAC, 50/60 Hz)	Motor Rating (VDC)	Continuous Output Current (Amps)	Peak Output Current (Amps)	FF	Product Type	Model Number
FPM Enclosed Filtered SCR DC Controls NEMA 12, Basic Speed Control							
1/17	115	90 or 130	0.5	1	1.0	FPM-0815E	0815
1/6			1.25	2.5		FPM-0835E	0835
1/3			2.3	4.6		FPM-0855E	0855

Type FPM | Filtered SCR DC Basic Speed and Direction Control (NEMA-12 Enclosure)



- Filtered DC output for different motor sizes.
- Designed to drive 90 Volt DC or 130 Volt DC motors
- Line voltage and temperature compensation
- Dynamic braking for quick stops
- Trim pots on PC board to adjust torque limit, minimum speed limit, maximum speed limit, acceleration time, and speed regulation
- Manual speed adjustment
- Rotary switch on enclosure for direction
- Terminal block inside enclosure for motor connection
- Back EMF feedback maintains better than 2% speed regulation
- Fuse holders for line and motor inside enclosure (fuses included)
- UR, CSA, RoHS

HP Rating	Input V (VAC, 50/60 Hz)	Motor Rating (VDC)	Continuous Output Current (Amps)	Peak Output Current (Amps)	FF	Product Type	Model Number
FPM Enclosed Filtered SCR DC Controls NEMA 12, Speed and Direction Control							
1/17	115	90 or 130	0.5	1	1.0	FPM-0818E	0818
1/6			1.25	2.5		FPM-0838E	0838
1/3			2.3	4.6		FPM-0858E	0858

Type FPM | Filtered SCR DC Remote Speed Control (NEMA-12 Enclosure)

- Designed to drive 90 Volt DC or 130 Volt DC motors
- Dip switches to easily calibrate control
- Line voltage and temperature compensation

- Trim pots on PC board to adjust torque limit, minimum speed limit, maximum speed limit, acceleration time, and speed regulation
- Speed can be adjusted manually
- Terminal block inside enclosure

- Back EMF feedback maintains better than 2% speed regulation
- Fuse holders for line and motor inside enclosure (both fuses supplied)
- UR, CSA, RoHS



HP Rating	Input V (VAC, 50/60 Hz)	Motor Rating (VDC)	Continuous Output Current (Amps)	Peak Output Current (Amps)	FF	Remote Signal	Product Type	Model Number
FPM Enclosed Filtered SCR DC Controls NEMA 12, Remote Speed Control								
1/17			0.5	1		Analog	FPM-0816E	0816
1/6	115	90 or 130	1.25	2.5	1.0	Analog	FPM-0836E	0836
1/3			2.3	4.6		Analog	FPM-0856E	0856

Type UPM | Unfiltered SCR DC Remote Speed Control

- Designed to drive 90 Volt DC or 130 Volt DC motors
- Switchable output for 0-90 Volt DC or 0-180 Volt DC.
- Back EMF feedback maintains better than 2% speed regulation.
- Dip switches to easily calibrate control

- Two diagnostic LEDs indicate when power is on and when current output is at limit set by TORQ pot
- Six on-board user-adjustable pots for torque limit, minimum speed limit, maximum speed limit, acceleration time, deceleration time and speed regulation

- Speed can be adjusted manually using a remote 10K speed pot (included with control)
- Unfiltered drive draws lower AC line current than comparable SCR filtered controls
- Connections for optional user-supplied inhibit switch
- cURus, CE, RoHS



HP Rating	Input V (VAC, 50/60 Hz)	Motor Rating (VDC)	Continuous Output Current (Amps)	Peak Output Current (Amps)	FF	Product Type	Model Number	
							1/4 in. QC tab	Terminal Block
UPM Unfiltered SCR DC Controls Chassis, Basic Speed Control								
1/5 @ 90 V 1/3 @ 180 V	115/230	90 or 130 @ 115 VAC 180 @ 230 VAC	2.1	4.2	1.6	UPM-3318C	0865	0866

Type UPM | NEMA-1 Unfiltered SCR Basic Speed Control (NEMA-1 Enclosure)

- Designed to drive 90 Volt DC or 130 Volt DC motors
- Line voltage compensation minimizes speed drift
- Back EMF feedback maintains better than 2% speed regulation.
- Dip switches to easily calibrate control

- Trim pots on PC board to adjust torque limit, minimum speed limit, maximum speed limit, acceleration time, deceleration time, and speed regulation
- Two diagnostic LEDs indicate when power is on and when current output is at limit set by TORQ pot

- Manual speed adjustment
- Terminal block inside enclosure
- Unfiltered drive draws lower AC line current than comparable SCR filtered controls
- Connections for optional user-supplied inhibit switch
- cURus, RoHS



HP Rating	Input V (VAC, 50/60 Hz)	Motor Rating (VDC)	Continuous Output Current (Amps)	Peak Output Current (Amps)	FF	Product Type	Model Number
UPM Enclosed Unfiltered SCR DC Controls NEMA 1, Basic Speed Control							
1/5	115	90 or 130	2.1	4.2	1.6	UPM-3318E1	0867

Type ABL | Low Voltage PWM BLDC Speed and Direction Control (Chassis, IP-00)



Models 3904, 3905 and 3907

- Ideal for portable, battery operated applications
- On-board speed potentiometer for manual adjustment
- Accepts 0-5 VDC analog signal for remote operation
- Unique Smart Reverse™ circuit provides quick reversing and prevents motor plugging
- Dynamic braking for quicker stops
- 12 pulse/revolution tach output provides indication of motor speed
- Models 3904, 3905 and 3907: Logic output indicates control shutdown due to a motor overload
- Speed can be adjusted manually or by remote control over a range of 30:1
- 10k Ohm remote speed pot supplied with each control
- Inherent closed loop system maintains a 2% maximum change in motor speed from 0-100% of rated load when operated at rated speed
- cURus, RoHS
- 60° commutation is standard

HP Rating	Input V (VDC)	Motor Rating (VDC)	Continuous Output Current (Amps)	Peak Output Current (Amps)	FF	Product Type	Model Number
Chassis Low Voltage PWM BLDC (24 V Models)							
1/6	24-35	24	10	13.5	1.0	ABL-3905C	3905
3/8			20	30		ABL-3907C	3907
Chassis Low Voltage PWM BLDC (12 V Model)							
Contact Factory	12-14	12	20	30	1.0	ABL-3907C	3904
Compact Chassis Low Voltage PWM BLDC (12 and 24 V Models)							
1/4	12-14	12	20	30	1.0	ABL-3906C	3908
3/8	24-35	24	18	27			3909
Compact Chassis Low Voltage PWM BLDC (24 V Model) 120° Commutation							
3/8	24-35	24	18	27	1.0	ABL-3919C	3919



Models 3908, 3909 and 3919

Type ABL | Filtered SCR BLDC Speed and Direction Control (Chassis, IP-00)



- Unique Smart Reverse™ circuit for remote control of motor direction
- Dynamic braking for quicker stops
- 12 pulse/revolution tach output
- Green LED indicates AC power on
- Red LED indicates control shutdown due to a fault condition
- Speed can be adjusted manually
- 10k Ohm remote speed pot supplied with each control
- DIP switches set the current limit
- Five onboard user-adjustable pots for torque limit, minimum speed limit, maximum speed limit, acceleration time, and deceleration time
- Fuse holders for line and motor fuses (fuses included)
- Inherent closed loop system maintains a 1% maximum change in motor speed from 0-100% of rated load when operated at rated speed
- UR, CSA, RoHS

HP Rating (@ rpm)	Input V (VAC, 50/60 Hz)	Motor Rating (VDC)	Continuous Output Current (Amps)	Peak Output Current (Amps)	FF	Product Type	Model Number
3/8@2500	115	130	3	6	1.0	ABL-3911C	3911
1/3@10,000						ABL-3921C	3921

Type ABL | Filtered SCR BLDC Speed/Direction Control (NEMA-12 Enclosure)



- Unique Smart Reverse™ circuit allows remote control of motor direction
- Dynamic braking for quicker stops
- 12 pulse/revolution tach output provides indication of motor speed
- Internal: Red LED indicates control shutdown due to a fault condition
- Speed can be adjusted manually
- DIP switches set the current limit
- Inherent closed loop system maintains a 1% maximum change in motor speed from 0-100% of rated load when operated at rated speed
- Fuse holders for line and motor fuses (fuses included)
- UR, CSA, RoHS

HP Rating (@ rpm)	Input V (VAC, 50/60 Hz)	Motor Rating (VDC)	Continuous Output Current (Amps)	Peak Output Current (Amps)	FF	Product Type	Model Number
3/8@2500	115	130*	3	6	1.0	ABL-3912E	3912
1/3@10,000						ABL-3913E	N3913

* for brushless motors and controls

Type ABL | Unfiltered SCR BLDC Speed and Direction Control (Chassis, IP-00)



- Lower cost alternative to model 3911
- Unique Smart Reverse™ circuit
- 12 pulse/revolution tach output
- Green LED indicates AC power on
- Red LED indicates control shutdown due to a fault condition
- Speed can be adjusted manually
- 10k Ohm speed pot supplied with each control
- DIP switches set the current limit so that the same control model can drive any size Bodine motor
- Inherent closed loop system maintains a 1% maximum change in motor speed from 0-100% of rated load when operated at rated speed
- UR, CSA, RoHS

HP Rating	Input V (VAC, 50/60 Hz)	Motor Rating (VDC)	Continuous Output Current (Amps)	Peak Output Current (Amps)	FF	Product Type	Model Number
3/8	115	90	3	6	1.6	ABL-3910C	3910

"N" model numbers require lead time and minimum quantities.



Metric Motors and Gearmotors

Our metric gearmotors and motors feature metric shafts and mounting configurations. AC metric motors are rated at 230 VAC / 50 Hz. Permanent magnet DC motors are available with voltage ratings of 180 VDC. Custom windings can be provided to match almost any international rating. We also offer a complete line of both AC and DC metric right angle and parallel shaft gearmotors.

Parallel Shaft Gearmotors—Metric

up to 0.67 Nm | Parallel Shaft Gearmotors—Metric

A/T

- Metric mounting threads and shaft dimensions
- Three-wire winding simplifies reversing
- Impedance protected to prevent current overload (gearmotor should not be stalled when powered up)
- See Page 36 for capacitors

Fixed Speed—AC Gearmotors

Speed (rpm)	Rated Torque		Power		Rated Voltage	Freq. (Hz)	Ph	Current (Amps)	Gear Ratio	Radial Load (oz.)	Capacitor (µF/VAC)	Product Type	Model Number
	oz-in.	Nm	HP	Watts									
7	95	0.67	1/300	2.8	230	50	1	0.06	180	20	0.4/440	KCI-26T4	N1757
42	75	0.53							30			KCI-26A2	N1754
69	45	0.31							18			KCI-26A2	N1753
210	15	0.11							6			KCI-26A2	N1752

CAPACITOR IS REQUIRED



Type K-2A/T

up to 4.5 Nm | Parallel Shaft Gearmotors—Metric

D

- Metric mounting threads and shaft dimensions
- Unvented gearhousing for universal horizontal mounting
- Helical primary gear for quietness and hardened steel spur gearing on subsequent stages for high output torque and long life
- See pages 36 and 37 for capacitors and accessories

Fixed Speed—AC Gearmotors

Speed (rpm)	Rated Torque		Power		Rated Voltage	Freq. (Hz)	Ph	Current (Amps)	Gear Ratio	Radial Load (lbs.)	Capacitor (µF/VAC)	Product Type	Model Number
	lb-in.	Nm	HP	Watts									
7.8	40	4.5	1/48	15	230	50	1	0.17	180	65	1.3/440	30R1BECI-D4	N1562
23	40	4.5	1/41	18				0.21	60			30R2BECI-D3	N1574
47	24	2.7	1/41	18				0.21	30			30R2BECI-D3	N1573
78	14	1.6	1/41	18				0.21	18			30R2BECI-D3	N1572
117	9.7	1.1	1/41	18				0.21	12			30R2BECI-D3	N1571

CAPACITOR IS REQUIRED



Type 30R-D

Permanent Magnet DC Gearmotors

Speed (rpm)	Rated Torque		Power		Rated Voltage	Current (Amps)	Gear Ratio	Radial Load (lbs.)	Product Type	Model Number
	lb-in.	Nm	HP	Watts						
5.8	40	4.5	1/49	15	180	0.13	300	65	24A2BEPM-D5	N1398
9.6	40	4.5	1/49	15		0.13	180		24A2BEPM-D4	N1397
29	40	4.1	1/32	23		0.18	60		24A4BEPM-D3	N1395
58	18	2.0	1/32	23		0.18	30		24A4BEPM-D3	N1394
144	7.3	0.8	1/32	23		0.18	12		24A4BEPM-D3	N1392



Type 24A-D

"N" model numbers require lead time and minimum quantities.

Visit www.bodine-electric.com for 2D/3D CAD drawings

www.bodine-electric.com

- Metric mounting threads and shaft dimensions
- Aluminum center ring and endshields
- Unvented gearhousing
- Industrial lip type seals on motor and output shafts
- Needle bearings on output shaft
- Permanently lubricated with high-performance lubricant
- Helical pinion accurately cut on motor shaft for maximum strength and minimum noise
- 34R-Z: die cast terminal box with terminal block included
- See Page 36 for capacitors

Fixed Speed—AC Gearmotors



Type 34R-Z

Speed (rpm)	Rated Torque		Power		Rated Voltage	Freq. (Hz)	Ph	Current (Amps)	Gear Ratio	Radial Load (lbs.)	Capacitor (µF/VAC)	Product Type	Model Number
	lb-in.	Nm	HP	Watts									
Permanent Split Capacitor, Non-synchronous (TEFC) CAPACITOR IS REQUIRED													
7.8	100	11.3	1/15	50	230	50	1	0.48	180	125	5.0/370	34R4BFCl-Z4	N1449
23	100	11.3						0.5	60	125		34R4BFCl-Z3	N1455
70	40	4.5						0.5	20	100		34R4BFCl-Z2	N1453
233	15	1.7						0.5	6	100		34R4BFCl-Z2	N1451

Permanent Magnet DC Gearmotors



Type 24A-Z



Type 33A-Z

Speed (rpm)	Rated Torque		Power		Rated Voltage	Current (Amps)	Gear Ratio	Radial Load (lbs.)	Product Type	Model Number
	lb-in.	Nm	HP	Watts						
24A-Z PMDC Gearmotor										
9.6	100	11.3	1/32	23	180	0.18	180	125	24A4BEPm-Z4	N1163
29	36	4.1					60	125	24A4BEPm-Z3	N1161
58	18	2.0					30	125	24A4BEPm-Z3	N1160
288	4	0.44					6	100	24A4BEPm-Z2	N1157
33A-Z PMDC Gearmotor										
29	69	7.8	1/23	32	180	0.33	60	125	33A3BEPm-Z3	N6269
58	35	3.9					30	125	33A3BEPm-Z3	N6268
144	15	1.7					12	100	33A3BEPm-Z2	N6266

Our metric PMDC motors and gearmotors are rated for operation with an unfiltered SCR speed control and a Form Factor (F.F.) of 1.6"

- Metric mounting threads and shaft dimensions
- Lubricated for life
- Synthetic lubricant improves performance, and allows these gearmotors to operate in a wide temperature range
- Models with accessory shafts are ideal for mounting encoders or brakes
- 34R-W: Die cast terminal box with terminal block included
- Adaptor plate, model 0995, allows for 3-hole mounting configuration. See Page 36.

Fixed Speed—AC Gearmotors



Type 34R-W

Speed (rpm)	Rated Torque		Power		Rated Voltage	Freq. (Hz)	Ph	Current (Amps)	Gear Ratio	Radial Load (lbs.)	Capacitor (µF/VAC)	Product Type	Model Number
	lb-in.	Nm	HP	Watts									
Permanent Split Capacitor, Non-synchronous CAPACITOR IS REQUIRED													
4.5	175	19.8	1/10	75	230	50	1	0.6	312.4	130	7.5/370	34R6BFCl-W4	N1477
21	146	16.5							65.5	130		34R6BFCl-W3	N1484
69	53	6							20.4	65		34R6BFCl-W2	N1481
255	14	1.6							5.5	65		34R6BFCl-W2	N1478

Permanent Magnet DC Gearmotors



Type 33A-W

Speed (rpm)	Rated Torque		Power		Rated Voltage	Current (Amps)	Gear Ratio	Radial Load (lbs.)	Product Type	Model Number
	lb-in.	Nm	HP	Watts						
5.5	175	19.8	1/23	32	180	0.33	312.4	130	33A3BEPm-W4	N6247
18	151	17.0	1/14	54		0.41	97.5	130	33A5BEPm-W4	N6256
39	78	8.8	1/14			0.41	43.9	130	33A5BEPm-W3	N6254
85	39	4.4	1/14			0.41	20.4	65	33A5BEPm-W2	N6252
125	27	3.0	1/14			0.41	13.8	65	33A5BEPm-W2	N6251
315	11	1.2	1/14			0.41	5.48	65	33A5BEPm-W2	N6249

"N" model numbers require lead time and minimum quantities.

Control models 1865 (see page 25) and 0865, 0866 (see page 27) are available for metric gearmotors and motors.

- Metric mounting threads and shaft dimensions
- Unvented gearhousing
- All steel gearing
- Industrial lip type seals on motor and output shafts
- Needle bearings throughout for increased radial load capacity and long life
- Permanently lubricated
- 42R-E: Die cast terminal box with terminal block included
- F-type only: Hardened helical gearing for quietness and high output to size ratio
- Dual voltage (230/460V) models are also available

Fixed Speed—AC Gearmotors

Speed (rpm)	Rated Torque		Power		Rated Voltage	Freq. (Hz)	Ph	Current (Amps)	Gear Ratio	Radial Load (lbs.)	Capacitor (µF/VAC)	Product Type	Model Number
	lb-in.	Nm	HP	Watts									
140	50	5.6	1/5	140	230/400	50	3	1.1/.61	10	300		42R5BFPP-E2	N1665
Three-phase, Non-synchronous													
Permanent Split Capacitor, Non-synchronous													
4.7	310	35	1/7.5	100	230	50	1	0.78	300	200	7.5/370	42R5BFCI-E4	N1671
7.8	341	38.5										42R5BFCI-E4	N1669
23	297	33.6										42R5BFCI-E3	N1685
47	148	16.7										42R5BFCI-E3	N1683
70	99	11.2										42R5BFCI-E3	N1681
140	50	5.6										42R5BFCI-E2	N1680
280	26	2.9										42R5BFCI-E1	N1679
Split phase Non-synchronous (with centrifugal switch)													
47	148	16.7	1/7.5	100	230	50	1	0.78	30	300		42R5BFSI-E3	N1653



Type 42R-E

Permanent Magnet DC Gearmotors

Speed (rpm)	Rated Torque		Power		Rated Voltage	Current (Amps)	Gear Ratio	Radial Load (lbs.)	Product Type	Model Number
	lb-in.	Nm	HP	Watts						
5.8	310	35	1/5	153	180	0.85	300	200	42A5BEPM-E4	N4275
29	310	35				1	60	200	42A7BEPM-E3	N4285
43	180	20				1	40	200	42A7BEPM-E3	N4284
85	120	13.6				1	20	300	42A7BEPM-E3	N4282
170	60	6.8				1	10	300	42A7BEPM-E2	N4280
170	68	7.7				1	10	300	42A7BEPM-F2	N4290
345	32	3.7				1	5	300	42A7BEPM-E1	N4279



Type 42A-E/F

- Metric mounting threads and shaft dimensions
- Industrial lip seals on motor and output shafts
- Needle bearings on output shaft for increased radial load capacity and long life
- Permanently lubricated with high-performance lubricant
- Bronze gear for high shock load capability
- Hardened and ground worm for high strength and long life
- 34R-3F: Die cast terminal box (IP-44) with terminal block included

Fixed Speed—AC Gearmotors

Speed (rpm)	Rated Torque		Power		Rated Voltage	Freq. (Hz)	Ph	Current (Amps)	Gear Ratio	Radial Load (lbs.)	Capacitor (µF/VAC)	Product Type	Model Number
	lb-in.	Nm	HP	Watts									
35	37	4.2	1/15	50	230	50	1	0.5	40	40	5.0/370	34R4BFCI-3F	N1491
47	34	3.8							30	40			N1487
70	30	3.4							20	40			N1490
140	19	2.1							10	5			N1488



Type 34R-3F

Permanent Magnet DC Gearmotors

Speed (rpm)	Rated Torque		Power		Rated Voltage	Current (Amps)	Gear Ratio	Radial Load (lbs.)	Product Type	Model Number
	lb-in.	Nm	HP	Watts						
43	16	1.8	1/32	23	180	0.18	40	40	24A4BEPM-3F	N1098
86	9.7	1.1					20			N1096
172	5.3	0.6					10			N1094



Type 24A-3F

"N" model numbers require lead time and minimum quantities.

Metric—Right Angle Gearmotors

5N/5F Metric—Right Angle Gearmotors | up to 12.8 Nm

- Metric mounting threads and shaft dimensions
- Unvented gearhousing for universal horizontal mounting
- Bronze worm gear for high shock load capability
- Hardened and ground worm for strength and long life
- Models with accessory shafts are ideal for mounting encoders or brakes
- *AC Gearmotors:* Die cast terminal box with terminal block included
- See page 42 for capacitors and terminal boxes

Fixed Speed—AC Gearmotors



Type 34R-5F



Type 42R-5F and 42R-5N

Speed (rpm)	Rated Torque		Power		Rated Voltage	Freq. (Hz)	Ph	Current (Amps)	Gear Ratio	Radial Load (lbs.)	Capacitor (µF/VAC)	Product Type	Model Number
	lb-in.	Nm	HP	Watts									
34R-5F Gearmotor													
<i>Permanent Split Capacitor, Non-synchronous</i>													
CAPACITOR IS REQUIRED													
23	72	8.1	1/15	50	230	50	1	0.5	60	50	5.0/370	34R4BFCI-5F	N1469
35	60	6.8	1/15						40	50			N1468
70	39	4.4	1/15						20	50			N1466
140	21	2.4	1/15						10	30			N1465
42R-5F Gearmotor													
<i>Permanent Split Capacitor, Non-synchronous</i>													
CAPACITOR IS REQUIRED													
35	93	10.5	1/9	83	230	50	1	0.63	40	80	7.5/370	42R4BFCI-5F	N1627
70	60	6.8	1/9						20	80			N1624
140	32	3.6	1/9						10	10			N1623
42R-5N Gearmotor													
<i>Three-phase, Non-synchronous</i>													
47	109	12.3	1/5	140	230/400	50	3	1/1.61	30	180	—	42R5BFPP-5N	N1633
<i>Permanent Split Capacitor, Non-synchronous</i>													
CAPACITOR IS REQUIRED													
35	113	12.8	1/7.5	100	230	50	1	0.78	40	180	7.5/370	42R5BFCI-5N	N1678
70	74	8.4							20				N1677

Permanent Magnet DC Gearmotors



Type 33A-5F



Type 42A-5N

Speed (rpm)	Rated Torque		Power		Peak Torque (lb-in.)	Rated Voltage	Current (Amps)	Gear Ratio	Radial Load (lbs.)	Product Type	Model Number
	lb-in.	Nm	HP	Watts							
33A-5F Gearmotor											
43	45	5.1	1/14	54	118	180	0.41	40	80	33A5BEPM-5F	N6244
86	29	3.3			100			20			N6242
173	17	1.9			54			10			N6241
345	8.9	1			28			5			N6240
42A-5N Gearmotor											
43	81	9.1	1/6	121	177	180	0.85	40	120	42A5BEPM-5N	N4238
85	55	6.2						20			N4236
172	31	3.5						10			N4235

5H Metric—Right Angle Gearmotors | up to 14.2 Nm

Permanent Magnet DC Gearmotors



Type 42A-5H

Speed (rpm)	Rated Torque		Power		Peak Torque (lb-in.)	Rated Voltage	Current (Amps)	Gear Ratio	Radial Load (lbs.)	Product Type	Model Number
	lb-in.	Nm	HP	Watts							
36	126	14.2	1/5	141	340	180	1	48	150	42A7BEPM-5H	N4299
96	81	9.2			247						18

"N" model numbers require lead time and minimum quantities.

- Metric mounting threads and shaft dimensions
- Unvented gearhousing for universal horizontal mounting
- Hardened helical output gearing
- Bronze worm gear for high shock load capability
- Hardened and ground worm hobbled on the motor shaft for high strength and long life
- Models with accessory shafts are ideal for mounting encoders or brakes
- See pages 34 and 35 for capacitors and terminal boxes
- 42R-GB: Die cast terminal box with terminal block included

Fixed Speed—AC Gearmotors

Speed (rpm)	Rated Torque		Power		Rated Voltage	Freq. (Hz)	Ph	Current (Amps)	Gear Ratio	Radial Load (lbs.)	Capacitor (µF/VAC)	Product Type	Model Number
	lb-in.	Nm	HP	Watts									
5	380	43	1/7.5	100	230	50	1	0.78	280	200	7.5/370	42R5BFCI-GB	N1266
7.4	375	42							190				N1264
12	290	33							120				N1262
23	204	23							60				N1260



Type 42R-GB

Permanent Magnet DC Gearmotors

Speed (rpm)	Rated Torque		Power		Rated Voltage	Current (Amps)	FF	Gear Ratio	Radial Load (lbs.)	Product Type	Model Number
	lb-in.	Nm	HP	Watts							
6.2	380	42.8	1/6	121 / 129	180	0.85 / 0.87	1.6 / 1.0	280	200	42A5BEPM-GB	N1366
9	358	40.4						190			N1364
14.4	250	28.3						120			N1362
28.8	150	17						60			N1360



Type 42A-GB

Metric Motors Without Gearing

- Die cast terminal box with terminal block included with 34R and 42R motors
- See Page 36 for capacitors and terminal boxes

up to 140 Watts | Fixed Speed AC Induction Motors—Metric

Speed (rpm)	Rated Torque		Power		Rated Voltage	Frequency (Hz)	Ph	Current (Amps)	Radial Load (lbs.)	Capacitor (µF/VAC)	Product Type	Model Number
	(oz-in.)	(Nm)	(HP)	(Watts)								
KCI-26												
CAPACITOR IS REQUIRED												
1250	3	0.02	1/300	2.8	230	50	1	0.06	5.7	0.4/440	KCI-26	N1713
30R												
CAPACITOR IS REQUIRED												
2850	9	0.06	1/39	19	230	50	1	0.38	18	1.3/440	30R2BECI	N1319
1400	18	0.13	1/41	18				0.21				N1340
34R												
1400	97	0.69	1/7.5	100	230/400	50	3	.78/45	42	No Capacitor	34R6BFPP	N1295
1400	72	0.51	1/10	75	230			0.6				34R6BFCI
42R												
1400	135	0.95	1/5	140	230/400	50	3	1.1/0.61	50	No Capacitor	42R5BFPP	N1273
1400	97	0.68	1/7.5	100	230			0.78				42R5BFCI



up to 200 Watts | Permanent Magnet DC Motors—Metric

Speed (rpm)	Rated Torque		Power		Rated Voltage	FF	Current (Amps)	Radial Load (lbs.)	Product Type	Model Number	
	(oz-in.)	(Nm)	(HP)	(Watts)							
33A (Face Mount, Base Optional)											
1725	25	0.18	1/23	32	180	1.6 / 1.0	55		33A3BEPM	N6216	
1725	55	0.39	1/11	70						33A5BEPM	N6227
1725	95	0.67	1/6	121						33A7BEPM	N6237
3000	55	0.39	1/6	122						33A5BEPM	N6230
3000	80	0.57	1/4	178						33A7BEPM	N6231
42A (Face or Base Mount, Base Installed)											
1725	95	0.68	1/6	121	180	1.6 / 1.0	90		42A5BEPM	N4227	
3000	70	0.49	1/5	155						42A5BEPM	N4230
1725	120	0.85	1/5	153						42A7BEPM	N4237
3000	90	0.63	1/4	200						42A7BEPM	N4231



"N" model numbers require lead time and minimum quantities.

AC | DC | BL "L" Brackets



Model No.	Description
A 0969	Kit for E, F and FX gearmotors (will not fit 48R-F or 48R-FX)
B 0970	Kit for WX gearmotors
C 0979	Kit for 34R and 34B motors
D 0980	Kit for 34R-Z gearmotors
E 0990	Kit for 24A motors
F 5968	Kit for 30R and 33A motors; 30R-D, 24A-D, 22B-D, 24A-Z, 33A-Z and 22B-Z gearmotors

AC | DC | BL Motor and Gearmotor Accessory Kits



Model No.	Description
A 0967	Base plate kit for 3F gearmotors
B 0977	IP-44 protection kit for 33A gearmotors and motors
C 0978	IP-44 protection kit for 42A gearmotors and motors
D 0984	Die cast terminal box kit for 34R, 42R, 48R, and 33A, 42A motors and gearmotors (DC: does not fit on 12 or 24VDC models)
E 0985	Oversized die cast t-box kit. Fits capacitor for use with 42R-FX gearmotors. Also fits 42R, 48R, 33A and 42A motors/gearmotors.
— 1982	Die cast terminal box with terminal block for 30R motors and gearmotors
— 1984	Die cast terminal box kit with terminal block for 34R, 42R, 48R, 33A and 42A motors/gmtrs. 90/130, 130V and 180VDC models only.
— 5982	Die cast terminal box for 30R motors and gearmotors
F 0992	Adaptor plate for mounting brakes or encoders for 33A/42A gearmotors/motors with accy. ready shaft extensions
G 0993	Adaptor plate for mounting brakes or encoders for 22B/34B gearmotors/motors with accy. ready shaft extensions
H 0995	3-hole adaptor plate for E, F, WX and FX gearmotors. Provides drop-in replacement for competitive gearmotors.
I 0991	Die cast base kit for 42A motors and gearmotors
J 0996	Base kit for 34R motors and gearmotors
K 0960	Mounting Flange for 60P planetary gearmotors (U.S.)
L 0961	Mounting Flange for 60P planetary gearmotors (Metric)
M 0962	IP-66 Seal Kit for 60P planetary gearmotors (U.S.)
N 0963	IP-66 Seal Kit for 60P planetary gearmotors (Metric)
O 0958	Base Mount Kit for 5L/H Hollow Shaft Gearmotors

AC Capacitors

Select a run capacitor based on the specifications found on pages 4-21 (29-33 for metric models) and in the tables below. The AC gearmotor or motor nameplate states the required capacitance of the run capacitor, but it is also critical to specify a capacitor that has the voltage ratings as shown in these tables. When using a run capacitor that is not supplied by Bodine Electric, please make sure the voltage rating is equal to or higher than the voltage rating specified on this page. Different motor sizes might require a different minimum voltage rating for the run capacitor.



Box-Type Capacitor



Metal Can-Type Capacitor

Capacitors

Part No.	µF /VAC	Part No.	µF /VAC	Part No.	µF /VAC
Box-Type Metalized Film Capacitor (Plastic Case)					
49400045 ¹	0.9/250	49426812 ¹	4.0/250	49401123 ¹	3.75/370
49400046 ¹	1.0/250	49401015	5.0/250	49401068 ¹	5.0/400
49400047 ¹	1.2/250	49401154 ^{1,3}	7.5/370	49401107 ¹	12.5/370
49400048 ¹	1.3/250	49401054	10.0/250	49401075 ¹	15.0/350
49400050 ¹	1.5/250	49401115 ¹	6.0/450	49401057	20.0/350
49400051 ¹	1.6/250	49401106	9.0/250	Round Metal Can-Type Capacitor	
49401049	0.4/440	49401006	12.5/250	49401124	25.0/370
49400091	1.3/440	49401156 ³	15.0/250	49401145 ²	45.0/250
49401047	2.3/250	49401113 ¹	20.0/250	49401147 ²	40.0/250
		49401112 ¹	27.5/250	49401148 ²	10.0/450
		49401090 ¹	30.0/250		

¹ Capacitor fits inside terminal box kit model 0984. ² Capacitor fits inside oversized terminal box model number 0985. ³ New capacitor part number effective 06/2016.

Capacitor Mounting Clamps

Model No.	Description
A 54701013	Mounting clamp for round, metal can type capacitor model 49401124
B 54701029	Mounting clamp for round, metal can type capacitors: models 49401145, 49401147, and 49401148

For mounting details and dimensions, visit www.bodine-electric.com



Shaft Kits for type 3F/H, 5L/H and GB/H hollow shaft gearmotors

Model No.	Description
0910	Shaft kit for type 3F/H gearmotors, 1/2 inch diameter, single shaft
0920	Shaft kit for type 3F/H gearmotors, 1/2 inch diameter, double shaft
0912	Shaft kit for type 5L/H gearmotors, 5/8 inch diameter, single shaft
0922	Shaft kit for type 5L/H gearmotors, 5/8 inch diameter, double shaft
0917	Shaft kit for type GB/H gearmotors, 3/4 inch diameter, single shaft
0927	Shaft kit for type GB/H gearmotors, 3/4 inch diameter, double shaft
0928	Shaft Kit for type 5L/H gearmotors, 5/8 inch to 3/4-inch diameter, single shaft
0950	Cover kit for type 3F/H gearmotors
0951	Cover kit for type 5L/H and GB/H gearmotors
0955	Flange mount kit for 3F/H gearmotors
0956	Flange mount kit for 5L/H and GB/H gearmotors

Encoder Shaft Kit for type 22B4-60P planetary gearmotors

0964	Encoder Shaft Kit, 3/8 inch diameter
------	--------------------------------------



Cover kits type 3F/H (left), types 5L/H and GB/H (right)



Flange mount kits type 3F/H (left), types 5L/H and GB/H (right)



Encoder Shaft Kit

Item	Model No.	Description
—	0888	Analog Interface Board for use with model 0810, 0830, and 0850 controls. Allows control to accept a variable voltage or current signal from user's host controller to automatically control motor speed. Inputs are optically isolated.
—	0890	Electronic Direction and Braking Board, F-B-R Kit , for use with model 0810, 0830, and 0850 controls. Allows user to change motor direction and to dynamically brake motor to a quick stop. Inputs are not optically isolated. This kit includes one F-B-R board, one cable and connector, mounting hardware, and two additional braking resistors.
—	0893	Local/Remote Switch for use with model 0810, 0830, and 0850 controls when used with accessory model 0888. Allows user to switch between automatic and manual operation.
—	0895	Switch Sealing Kit upgrades NEMA-12 brushless DC and PMDC enclosed controls to IP-44 rating.
A	3981	Cable Kit for stock 34B/FV INTEGRAMotors. Length: six feet (3 cables: power, logic and encoder).
B	3982	Extension Cable for model 3910, 3911, 3921 and 3912 controls. Extends the cable between the motor and control by six feet. Both ends are equipped with circular connections for easy connection between model 3983 cable assembly or encased control and the motor. Length: six feet.
C	3983	Connection Cable Assembly for connecting model 3910, 3921 and 3911 chassis controls to stock 130 V motors. One end of the cable is equipped with a circular connector, the other end is equipped with quick disconnects for phase leads, and a molded connector for the commutation leads. Length: 6 feet.
D	3984	Analog Interface And Isolation Module for model 3910, 3911, 3921 and 3912 controls. Provides Analog interface and isolates controls from system controller input signals which may be at different potentials.
—	43300260	Speed Potentiometer Kit for use with FPM controls. Contains 10k Ohm potentiometer, hardware, wire and connector for manually regulating motor speed.
—	43300270	Fuse and Speed Potentiometer Kit for use with model 3910 control. Contains potentiometer for manually regulating motor speed and various fuses to cover the range of motors and gearmotors which can be used with the control.

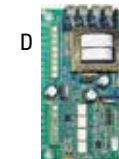

D

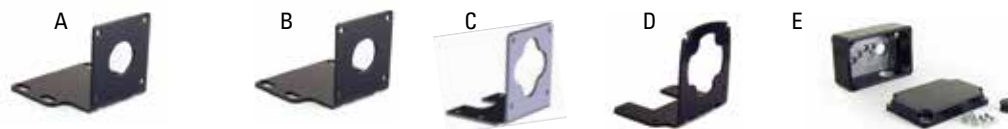

Metric "L" Brackets

Item	Model No.	Description
A	0990	Metric Kit for 24A
B	1968	Metric Kit for 33A motors, and type D and Z gearmotors
C	1970	Metric Kit for type W gearmotors
D	1969	Metric Kit for E, F and FX gearmotors (will not fit 48R-F or 48R-FX)
—	—	no "L" bracket kits are available for 34R and 34R-Z gearmotors

Metric Motor and Gearmotor Kits

Item	Model No.	Description
E	1982	Metric die cast terminal box kit for 30R motors and gearmotors
E	1984	Metric die cast terminal kit with terminal block for 33A, 34R, 42A and 42R motors and gearmotors. For 90/130, 130V and 180VDC models only.

Reference Drawings and Dimensions

60P Planetary Gearmotor Dimensions

Dimensions (in inches unless otherwise noted) are for reference only. For CAD drawings and specs, visit bodine-electric.com.

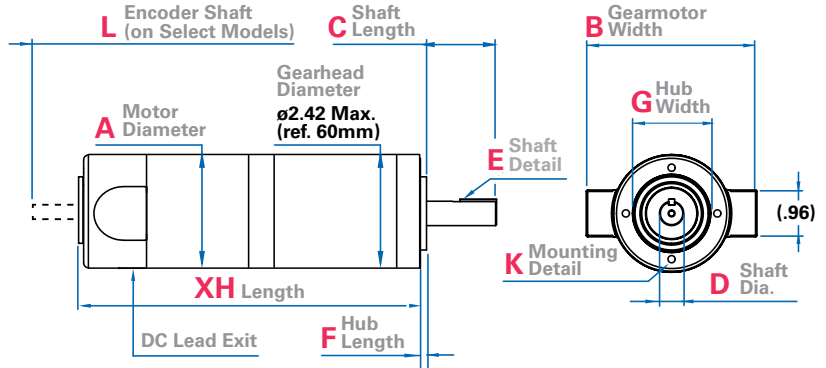

Gearhead Type 60P, page 4

	Product Type	Wt. (lbs.)	XH Length Max.	A Diameter	B Width	C Shaft Length	D Shaft Diameter	E Shaft Detail	F Hub Length	G Hub Width	H Mounting Pattern Width	K Mounting Detail	L Encoder Shaft	Cord/Lead Length (in.)
24A-60P	24A4-60P1	4.5	7.083	2.42	3.57 Max.	1.56	.500 tapped end hole	Key	.125	1.5	90° on a ø2.000 BC	[4] #10-32 UNF-2B	No	24 Ref.
	24A4-60P2	5.0	7.693											
	24A4-60P3	5.5	8.303											
24A-60P Metric	24A4-60P1	2.0 kg	180 mm	61.5 mm	91 mm Max.	35 mm	14 mm h6	Key	3mm	40 mm h7	90° on a ø52 mm BC	[4] M5x0.8-6h	No	610 mm
	24A4-60P2	2.3 kg	195 mm											
	24A4-60P3	2.5 kg	211 mm											
22B-60P	22B4-60P1	5.1	7.04	2.39	2.39	1.56	.500 tapped end hole	Key	.118	1.5	90° on a ø2.000 BC	[4] #10-32 UNF-2B	Optional	24 Ref.
	22B4-60P2	5.7	7.65											
	22B4-60P3	6.2	8.26											
22B-60P Metric	22B4-60P1	2.3 kg	179 mm	60.71 mm	60.71 mm Max.	35 mm	14 mm h6	Key	3mm	40 mm h7	90° on a ø52 mm BC	[4] M5x0.8-6h	Optional	610 mm
	22B4-60P2	2.6 kg	194 mm											
	22B4-60P3	2.8 kg	210 mm											

D Parallel Shaft Gearmotor Dimensions

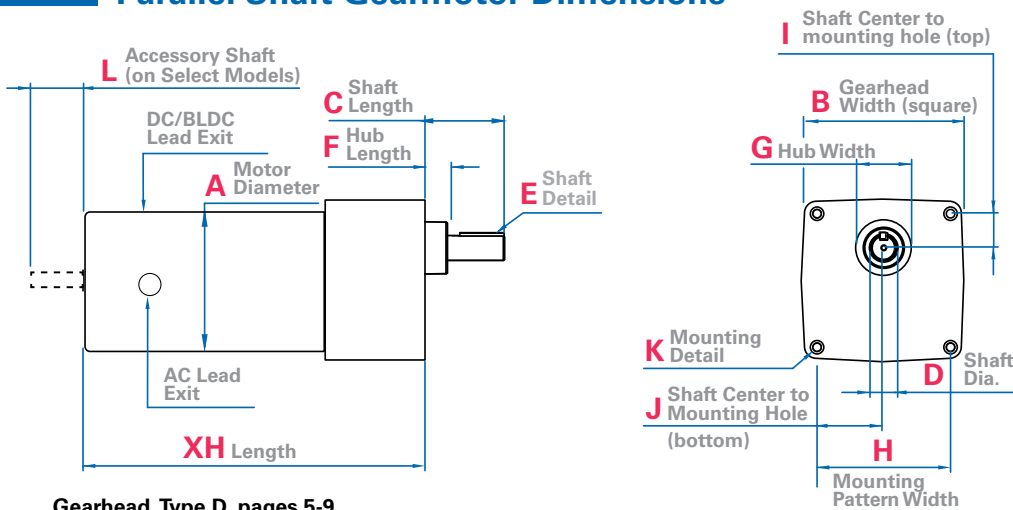

Gearhead Type D, pages 5-9

	Product Type	Wt. (lbs.)	XH Length	A Diameter (Height)	B Width	C Shaft Length	D Shaft Diameter	E Shaft Detail	F Hub Length	G Hub Width	H Mounting Pattern Width	I Shaft Center to Mounting Hole (top)	J Shaft Center to Mounting Hole (bottom)	K Mounting Detail	L Acc'y Shaft	Cord/Lead Length (in.)
Type D Gearmotor																
24A-D	24A2-D	4.0	5.887	2.42	3.42	1.56	.500	Flat	.554	1.125	2.652	.582	1.326	[4]10-32 UNF-2B x .38 deep on a 3.75 B.C.	Yes	24
	24A4-D	4.5	6.637												Yes	24
22B-D	22B2-D	3.75	5.522	2.378											Yes	12 or 24
22B-D INTEGRA	22B2-D	5.4	6.631	2.93											No	None

Only the first four characters of the product type are relevant to dimensions.

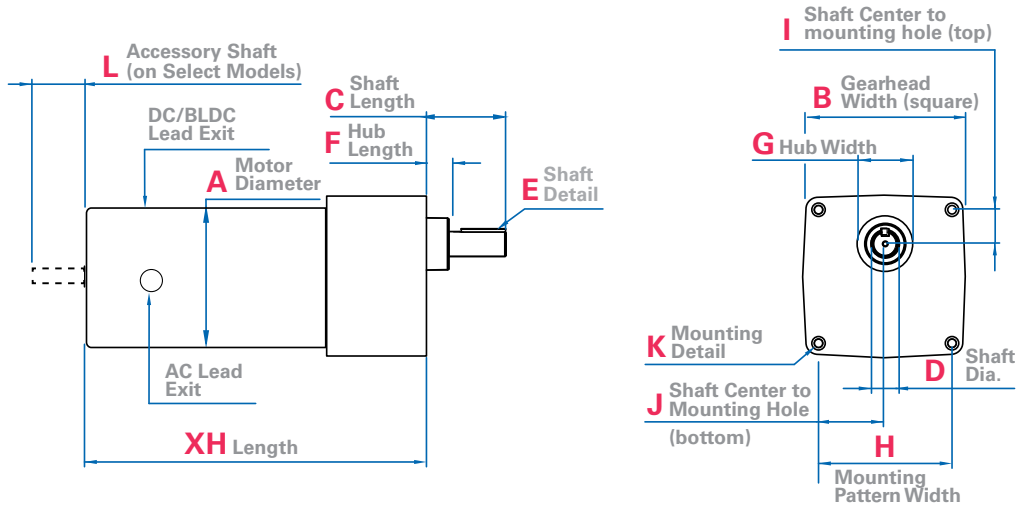

Gearhead Type Z, WX, FX pages 6-10

	Product Type	Wt. (lbs.)	XH Length	A Diameter (Height)	B Width	C Shaft Length	D Shaft Diameter	E Shaft Detail	F Hub Length	G Hub Width	H Mounting Pattern Width	I Shaft Center to Mounting Hole (top)	J Shaft Center to Mounting Hole (bottom)	K Mounting Detail	L Acc'y Shaft	Cord/Lead Length (in.)
Type Z Gearmotor																
34R-Z	34R4-Z4/3	9.3	8.328	4.02	3.40	1.56	.500	Flat/Key	.29	1.125	2.652	.582	1.326	[4]10-32 UNF-2B x .38 deep on a 3.75 B.C.	No	12
	34R6-Z4/3		8.345													
	34R4-Z2		7.428													
	34R6-Z2		7.445													
24A-Z	24A4-Z2	5.0	6.890	2.42	3.40	1.56	.500	Flat/Key	.29	1.125	2.652	.582	1.326	[4]10-32 UNF-2B x .38 deep on a 3.75 B.C.	Yes	24
	24A4-Z3/Z4		7.790													
33A-Z	33A3-Z2	5.8	6.895	3.39	3.40	1.56	.500	Flat/Key	.29	1.125	2.652	.582	1.326	[4]10-32 UNF-2B x .46 deep on a 3.75 B.C.	Yes	24
	33A3-Z3	5.8	7.795													
	33A5-Z2	6.8	7.960													
	33A5-Z3	6.8	8.860													
22B-Z	22B3-Z2	5.25	6.326	2.378	3.42	1.56	.500	Flat/Key	.29	1.125	2.652	.582	1.326	[4]10-32 UNF-2B x .46 deep on a 3.75 B.C.	Yes	12 or 24
	22B2-Z4	4.75	6.746													
	22B3-Z4	5.25	7.226													
22B-Z INTEGRA	22B3-Z2	5.3	7.435	2.93	3.42	1.56	.500	Flat/Key	.29	1.125	2.652	.582	1.326	[4]10-32 UNF-2B x .46 deep on a 3.75 B.C.	No	None
	22B3-Z3	5.3	8.335													
	22B2-Z4	4.8	7.885													
Type WX Gearmotor																
34R-WX	34R6-WX	12.0	8.956	4.02	4.06	2.0	.625	Key	.56	1.31	3.375	.863	1.688	[4]1/4 -28 UNF-2B x .50 deep on a 4.78 B.C.	No	12
33A-WX	33A5-WX	9.7	8.665	3.385												
34B-WX	34B3-WX	4.8	6.473	4.02												
Type E/F & FX Gearmotor																
34R-FX	34R4-FX	11.0	8.112	4.02	4.64	2.0	.750	Key	.37	1.536	3.625	.913	1.813	[4]1/4 -28 UNF-2B x .50 deep on a 5.13 B.C.	No	12
42R-FX	42R5-FX	14.5	9.128	4.73												
	42R6-FX	16.5	9.565	4.73												
48R-FX	48R6-FX	26.0	10.487	5.90												
42A-FX	42A5-FX	14.9	9.323	4.26												
34B-E/F	34B3-E	11.0	6.629	4.02	4.64	2.0	.750	Key	.37	1.536	3.625	.913	1.813	[4]1/4 -28 UNF-2B x .50 deep on a 5.13 B.C.	No	12 or 24
	34B4-E/F	12.0	7.129													
	34B6-F	14.0	8.129													

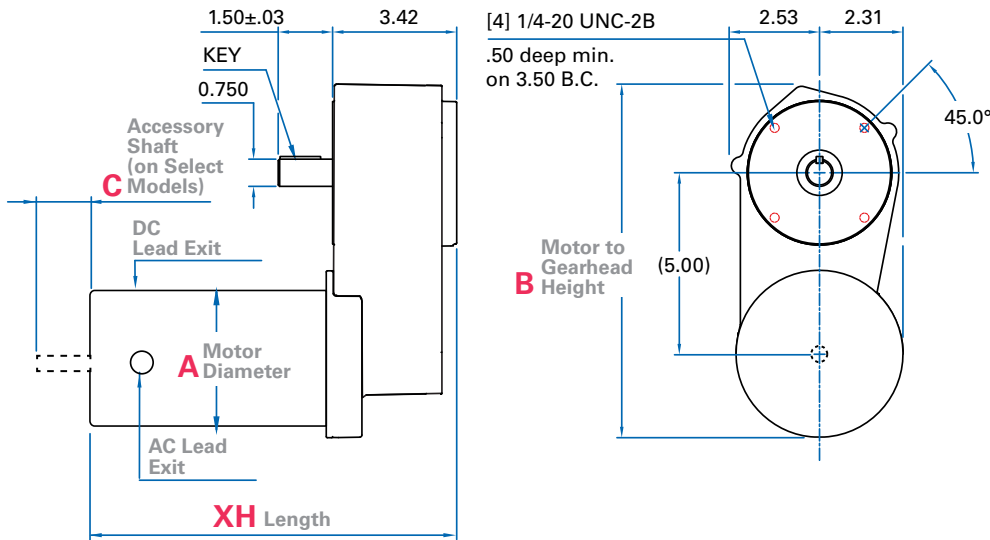

Gearhead Type HG, page 11

	Product Type	Weight (lbs.)	XH Length	A Diameter	B Height	C Acc'y Shaft	Lead/Cord Length (in.)
42R-HG	42R6-HG	9.5	9.855	4.73	9.85	No	12
33A-HG	33A7-HG	10.5	10.547	3.39	9.80	Yes	24

Only the first four characters of the product type are relevant to dimensions

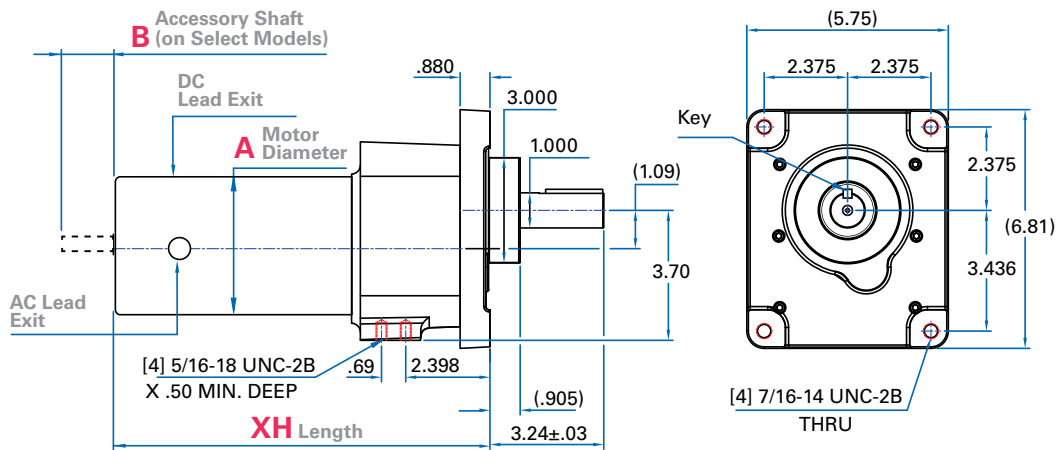

Gearhead Type CG, page 11-12

	Product Type	Weight (lbs.)	XH Length	A Diameter	B Acc'y Shaft	Lead/Cord Length (in.)
48R-CG	48R6-CG	34	12.849	5.917	No	12
42A-CG	42A7-CG	29	12.07	4.262	Yes	24

Only the first four characters of the product type are relevant to dimensions

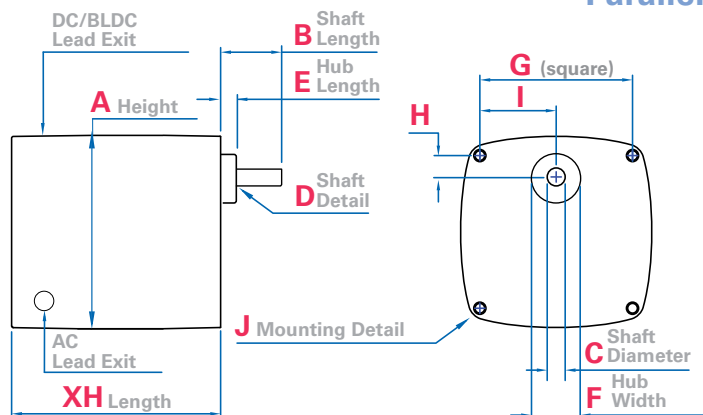

Gearhead Type 30R-D, K-2A/T, pages 5, 12

	Product Type	Wt. (lbs.)	XH Length (square)	A Height (square)	B Shaft Length	C Shaft Diameter	D Shaft Detail	E Hub Length	F Hub Width	G Mounting Pattern Width	H Shaft Center to Mounting Hole	I Shaft Center to Mounting Hole	J Mounting Detail	Lead/Cord Length (in.)
Type K-2 Gearmotor														
K-2T	22	2.2	2.539	2.38	1.00	.250	Flat	.255	.52	1.900	.356	.950	[2]8-32 UNC-2A	12
	23	2.4	2.664											
	24	2.7	3.023											
K-2A	23	2.3	2.507	2.38	1.00	.250	Flat	.255	.52	1.900	.356	.950	[2]8-32 UNC-2A	12
	24	2.6	2.866											
Type 30R-D Gearmotor														
30R-D	30R1	5.8	5.242	3.45	1.56	.500	Flat	.554	1.125	2.652	.582	1.326	[4]10-32 UNF-2B x .38 deep Max.	12
	30R2	6.3	5.492											
	30R4	7.5	6.000											

Right Angle Gearmotor Dimensions 3N | 3F

Dimensions (in inches) are for reference only. For CAD drawings and specs, visit bodine-electric.com.

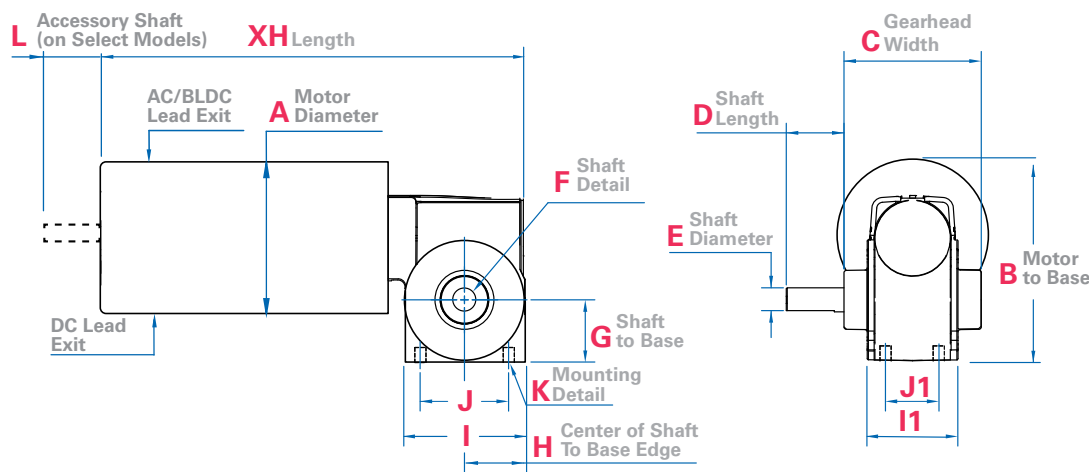

Gearhead Type 3N/3F, pages 13-14 (Mounts from Gearhead)

	Weight (lbs.)	XH Length	A Dia-meter	B Motor to Base	C Gearhead Width	D Shaft Length	E Shaft Diameter	F Shaft Detail	G Shaft to Base	H Center of Shaft to Base	I Base Length	I1 Base Width	J Mounting Hole Length	J1 Mounting Hole Width	K Mounting Detail	L Acc'y Shaft	Cord/Lead Length (in.)
30R4-3N	7.5	7.192	3.34	4.30	2.871	1.00	.500	Flat	1.28	1.28	2.56	2.111	2.00	1.188	[4]1/4 -20 UNF-2B x .50 deep	No	12
34R4-3F	9.3	8.61	4.02	4.37												No	12
24A4-3F	5.3	7.422	2.42	3.57												Yes	24
22B4-3N	5.4	7.677	2.378	3.80												No	12 or 24
22B4-3N INTEGRA	5.4	8.79	2.93	3.82												No	None

Only the first four characters of the product type are relevant to dimensions

Right Angle Gearmotor Dimensions

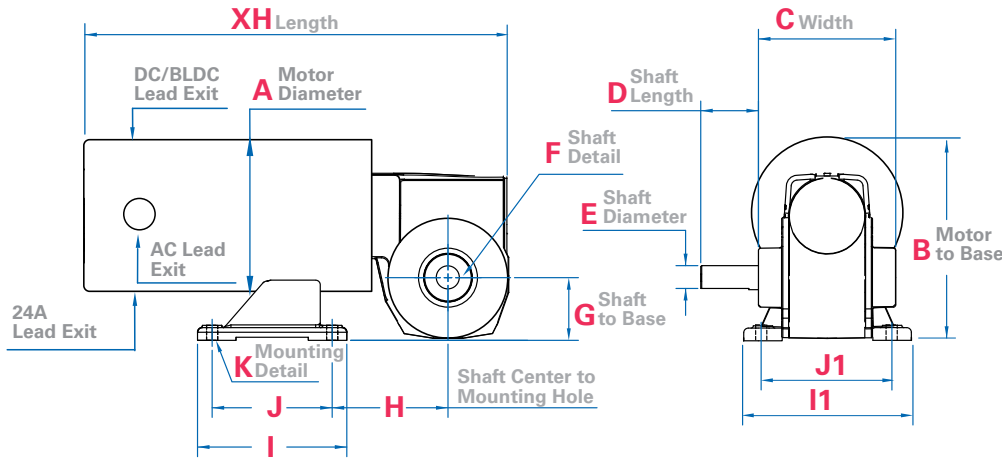

Gearhead Type 3F, 5R/5L, pages 14-16 (Mounts from Motor)

	Weight (lbs.)	XH Length	A Dia-meter	B Motor to Base	C Width	D Shaft Length	E Shaft Diameter	F Shaft Detail	G Shaft to Base	H Shaft Center To Mounting Hole	I Base Length	I1 Base Width	J Mounting Hole Length	J1 Mounting Hole Width	K Mounting Detail	Cord/Lead Length (in.)
Type 3F Gearmotor																
24A4-3F	5.3	7.422	2.42	3.57	2.871	1.00	.500	Flat	1.28	3.14	2.50	3.62	1.25	2.94	[4] ø.28	24
Type 5R Gearmotor																
34R4-5R	11.5	9.206	4.02	5.24	3.568	1.50	.625	Key/Flat	1.63	3.01	3.88	4.38	3.12	3.38	[4] ø.29	12
33A3-5R	9.0	8.651	3.39	4.92												24
Type 5L Gearmotor																
42R4-5L	13.5	9.54	4.73	5.57	3.568	1.50	.625	Key/Flat	1.56	2.856	4.38	5.02	3.62	4.00	[4] ø.30	12
42A4-5L	14.1	9.635	4.26	5.54												24

Right Angle Gearmotor Dimensions

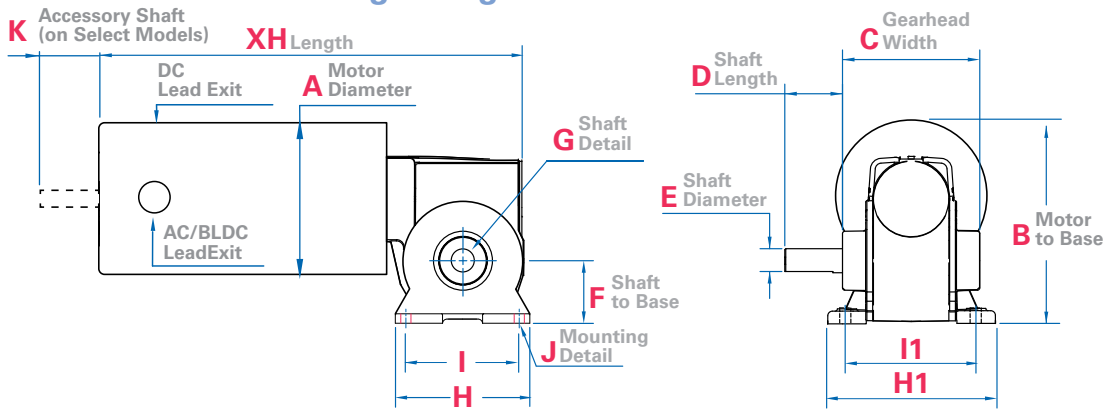

Gearmotor Type 5N, 5F, 5H, pages 15, 17, 18 (Mounts from Gearhead with Feet)

	Product Type	Wt. (lbs.)	XH Length	A Dia-meter	B Motor to Base	C Gearhead Width	D Shaft Length	E Shaft Diameter	F Shaft to Base	G Shaft Detail	H Base Length	H1 Base Width	I Mounting Hole Length	I1 Mounting Hole Width	J Mounting Detail	K Acc'y Shaft	Cord/Lead Length (in.)
Type 5N Gearmotor																	
42R-5N	42R5-5N	15.5	10.103	4.73	5.64	3.568	1.50	.625	1.67	Key/Flat	3.56	3.81	3.00	3.25	[4]ø .271/.266 Holes	No	12
	42A-5N	42A5-5N	14.3													10.198	4.62
34B-5N	34B3-5N	9.0	7.723	4.02	5.26	3.568	1.50	.625	1.67	Key/Flat	3.56	3.81	3.00	3.25	[4]ø .271/.266 Holes	No	12 or 24
	34B4-5N	10.0	8.223													Yes	
	34B6-5N	12.0	9.233													No	
Type 5F Gearmotor																	
34R-5F	34R6-5F	12.0	10.206	4.02	5.28	3.568	1.50	.625	1.67	Key/Flat	3.56	3.81	3.00	3.25	[4]ø .271/.266 Holes	No	12
33A-5F	33A5B-5F	9.9	9.711	3.39	4.96											No	24
	33A5F-5F	9.9	9.701													Yes	
Type 5H Gearmotor																	
48R-5H	48R6-5H	40.0	12.928	5.90	8.07	4.723	2.38	.750	3.000	Key	5.62	6.263	3.875	5.373	[4]ø.41/.44 Holes	No	12
42A-5H	42A7-5H	24.4	12.947	4.26	7.25											Yes	24

Only the first four characters of the product type are relevant to dimensions

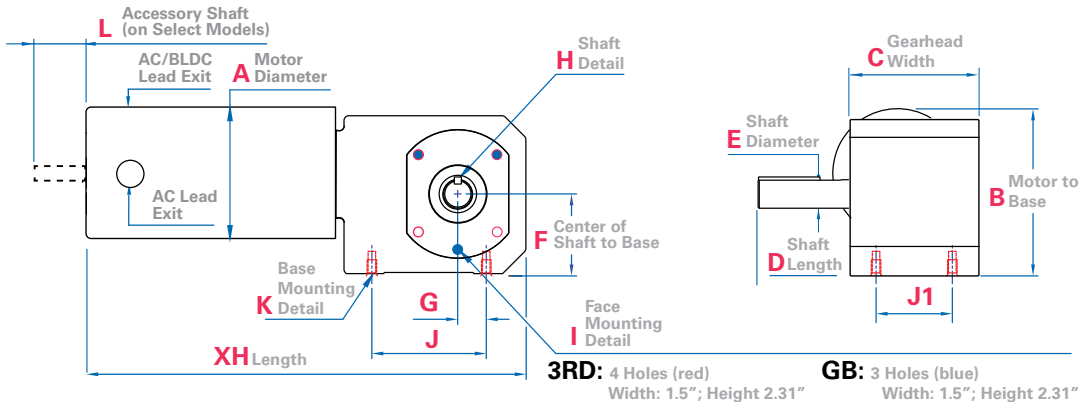

Gearhead Type 3RD, GB, pages 18-19

	Product Type	Wt. (lbs.)	XH Length	A Dia-meter	B Motor to Base	C Gear-head Width	D Shaft Length	E Shaft Diameter	F Shaft to Base	G Shaft to Mounting Hole Center	H Shaft Detail	I Face Mounting Detail	J Mounting Hole Length	J1 Mounting Hole Width	K Base Mounting Detail	L Acc'y Shaft	Cord/Lead Length (in.)
Type 3RD Gearmotor																	
30R-3RD	30R2	9.0	8.140	3.36	4.812	3.60	1.50	.500	1.562	.625	Flat	[4]10-32 UNF-2B x .31 Deep Min.	2.000	2.50	[4]1/4 -20 UNF-2B .31 deep	No	12
	30R4	10.5	8.640														24
24A-3RD	24A2	9.0	8.07	2.42	4.147	3.60	1.50	.500	1.562	.625	Flat	[4]10-32 UNF-2B x .31 Deep Min.	2.000	2.50	[4]1/4 -20 UNF-2B .31 deep	No	24
	24A4	10.5	8.82														12 or 24
22B-3RD	22B2	6.5	8.085	2.378	4.377	3.60	1.50	.500	1.562	.625	Flat	[4]10-32 UNF-2B x .31 Deep Min.	2.000	2.50	[4]1/4 -20 UNF-2B .31 deep	No	12 or 24
	22B4	6.5	9.045														12 or 24
Type GB Gearmotor																	
42R-GB	42R5	17.5	11.458	4.73	5.06	3.335	2.38	.750	2.150	.75	Key	[3]5/16 -18 UNF-2B x .50 Deep Max. on 2.913 B.C.	3.00	2.00	[4]1/4 -20 UNF-2B .40 Deep Min.	No	12
	42R6	19.5	11.893				2.38	.750									[4]1/4 -20 UNF-2B .40 Deep Min.
33A-GB	33A5	13.6	11.067	3.39	4.38	3.335	2.38	.750	2.150	.75	Key	[3]5/16 -18 UNF-2B x .50 Deep Max. on 2.913 B.C.	3.00	2.00	[4]1/4 -20 UNF-2B .40 Deep Min.	Yes	12
	33A7	14.9	12.268				2.362	.748									[4] M6 X 1-6H .45 Deep Max.
42A-GB	42A5	18.0	11.554	4.26	4.82	3.335	2.38	.750	2.150	.75	Key	[3]5/16 -18 UNF-2B x .50 Deep Max. on 2.913 B.C.	3.00	2.00	[4]1/4 -20 UNF-2B .45 Deep Min.	Yes	24

Hollow Shaft Gearmotor Dimensions

Dimensions (in inches) are for reference only. For CAD drawings and specs, visit bodine-electric.com.

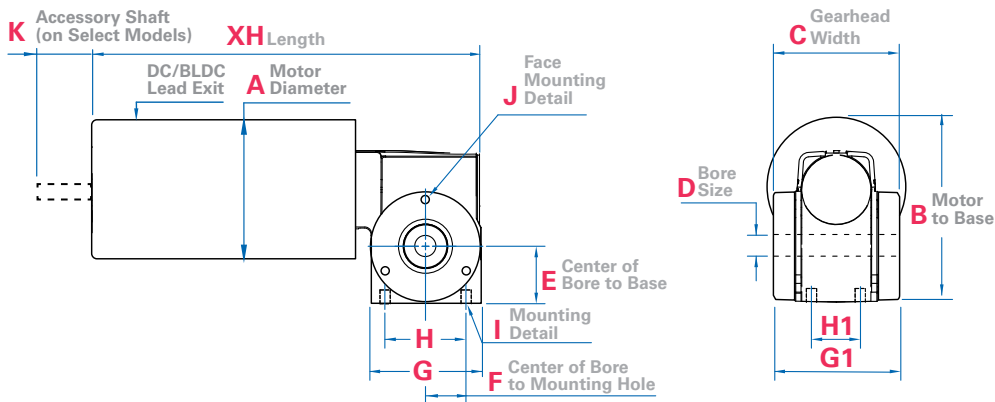

Gearhead Type 3F/H, pages 13-14 (Mounts from Gearhead)

	Weight (lbs.)	XH Length	A Dia-meter	B Motor to Base	C Gearhead Width	D Bore Size	E Bore to Base	F Bore to Mtg. Hole	G Base Length	G1 Base Width	H Mounting Hole Length	H1 Mounting Hole Width	I Mounting Detail	J Face Mount Detail	K Acc'y Shaft	Cord/Lead Length (in.)
24A4-3F/H	5.3	7.422	2.42	3.57	3.085	.502	1.280	1.000	2.56	3.085	2.00	1.188	[4] 1/4 -20 UNF-2B .35 Min. Deep on 2.125 B.C.	Yes	24	
22B4-3F/H	5.4	7.677	2.378	3.80											No	12 or 24
22B4-3F/H INTEGRA	5.4	8.79	2.93	3.823											No	None

Only the first four characters of the product type are relevant to dimensions

5L/H Hollow Shaft Gearmotor Dimensions

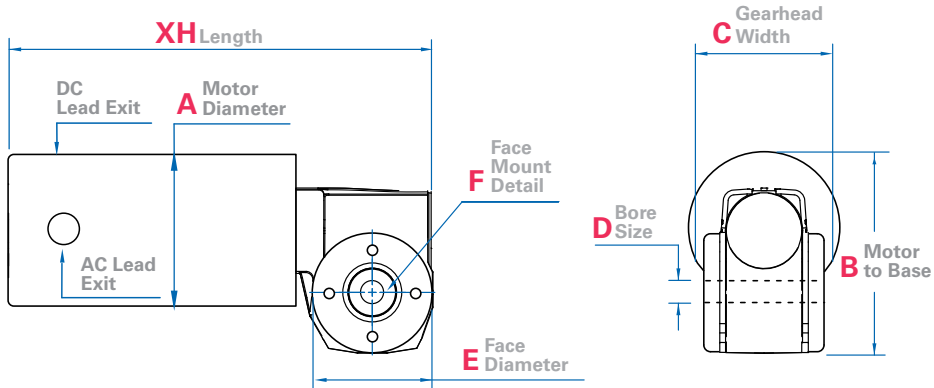

Gearhead Type 5L/H, pages 15-16 (Face Mount)

	Product Type	Weight (lbs.)	XH Length	A Diameter	B Motor to Base	C Gearhead Width	D Bore Size	E Face Diameter	F Face Mount Detail	Lead/Cord Length (in.)
33A-5L/H	33A5		9.711	3.39	5.04	2.740	.627	3.50	[4] 1/4-20 UNF-2B x .44 Min. Deep on 2.375 B.C.	24
42R-5L/H	42R6		10.540	4.73	5.71					None

GB/H Right Angle Gearmotor Dimensions

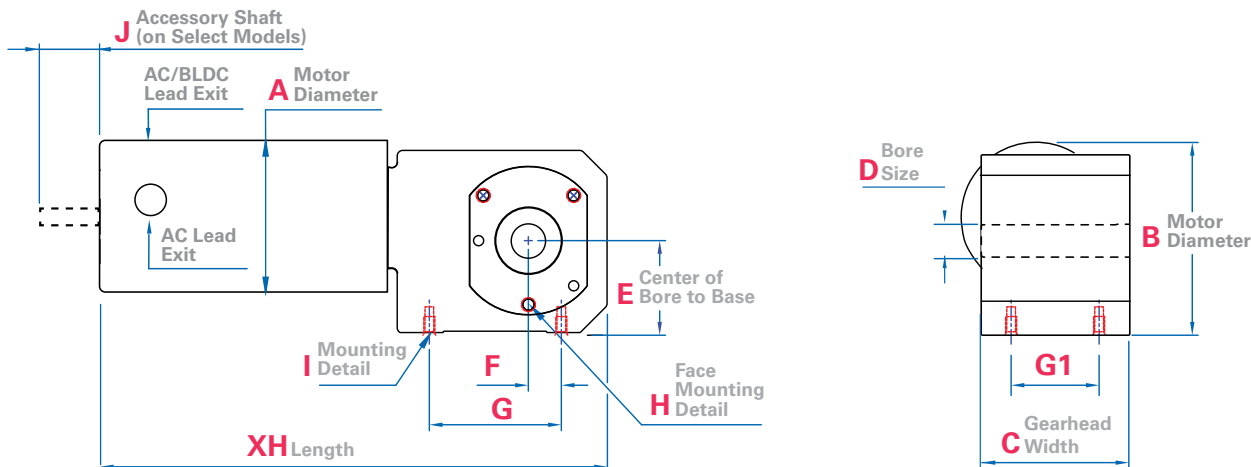

Type GB/H, page 19 (Face Mount)

	Product Type	Wt. (lbs.)	XH Length	A Dia-meter	B Motor to Base	C Gearhead Width	D Bore Size	E Bore to Base	F Center of Shaft to Mounting Hole	G Mounting Hole Length	G1 Mounting Hole Width	H Face Mounting Detail	I Mounting Detail	J Acc'y Shaft	Lead/Cord Length (in.)
42R-GB/H	42R5	17.5	11.456	4.73	5.06	3.335	.752	2.150	.75	3.00	2.00	[3] 5/16-18 UNF-2B x .44 Max. Deep on 2.913 B.C.	[4] 1/4-20 UNF-2B x .40 Min. Deep	No	12
	42R6	19.5	11.893											24	
33A-GB/H	33A5	13.6	11.067	3.39	4.38									No	24
42A-GB/H	42A5	19.5	11.554	4.26	4.82									Yes	24

Only the first four characters of the product type are relevant to dimensions

Dimensions (in inches) are for reference only. For CAD drawings and specs, visit bodine-electric.com.

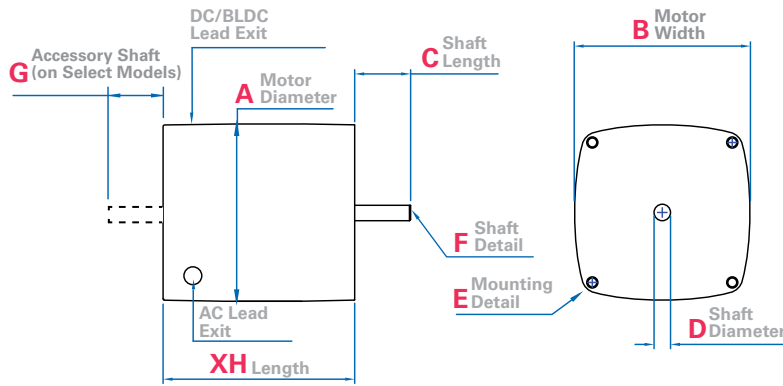

Motor Type K-2, 30R, 22B, pages 21-22, 25

	Product Type	Weight (lbs.)	XH Length	A Diameter Square	B Width	C Shaft Length	D Shaft Diameter	E Mounting Detail	F Shaft Detail	G Acc'y Shaft	Lead/Cord Length (in.)
K-2	K2-23	1.6	1.827	2.38	2.38	.62	.188	[4] 8-32 UNC-2B x .18 Deep Max. on 2.687 B.C.	Flat	No	12
	K2-24	1.9	2.20								
	K2-26	2.2	2.50								
K-2 Torque Motor	Model 0621	2.2	2.484								
30R	30R2	4.75	3.665	3.34	3.34	1.06	.313	[4]10-32 UNF-2B x .32 deep Max. on 3.75 B.C.	Flat	Yes	12
	30R4	6.2	4.200								
30R Torque Motor	Model 5625	4.75	3.665								
22B	22B2	2.5	3.610	2.378	2.378	.94	.375	[4] 8-32 UNC-2B x .35 Deep Max. on 2.625 B.C.	Flat	Yes	12 or 24
	22B4	3.5	4.570								
22B INTEGRA	22B2	2.5	4.719	2.93	2.93					No	None
	22B4	3.5	5.679								

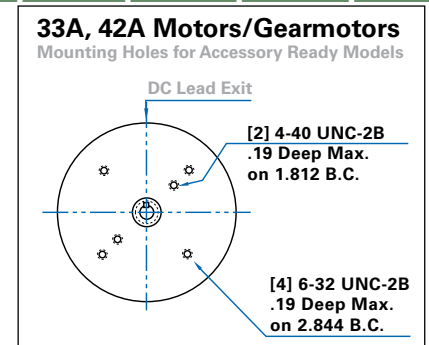
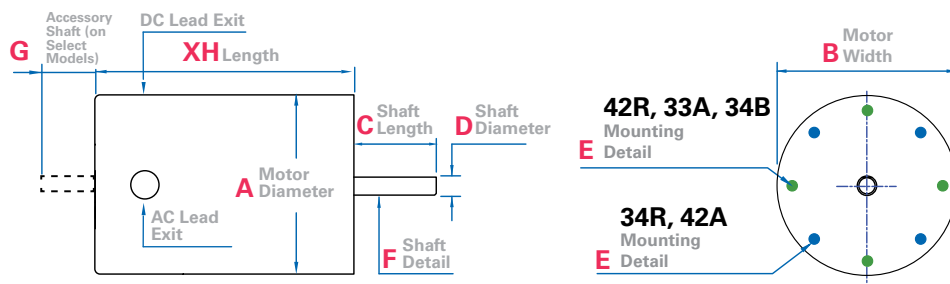

Motor Type 34R, 42R, 33A, 42A, 34B, pages 21-25 (Face Mount)

	Product Type	Weight (lbs.)	XH Length	A Diameter	B Width (PMDC)	C Shaft Length	D Shaft Diameter	E Mounting Detail	F Shaft Detail	G Acc'y Shaft	Lead/Cord Length (in.)
34R	34R4	7.0	5.69	4.02	—	1.25	.375	[4] 1/4-20 UNC-2B x .31 Min. Deep on 2.75 B.C.	Flat	No	12
	34R6	9.0	6.69								
42R	42R3	7.75	5.616	4.73	—	1.38	.375	[4] 1/4-20 UNC-2B x .31 Min. Deep on 3.75 B.C.	Flat	No	12
	42R5	11.0	6.679								
	42R6	13.0	7.116			1.125					
33A	33A3	5.1	5.140	3.39	3.75	1.48	.375	[4] 10-32 UNF-2B x .25 Min. Deep on 2.75 B.C.	Flat	Yes	24
	33A5	6.28	6.200								
	33A7	7.45	7.401								
42A NEMA 42C	42A5	11.3	6.656	4.26	4.25	1.62	.500	[4] 1/4-20 UNC-2B x .31 Min. Deep on 3.75 B.C.	Flat	Yes	24
	42A7	14.5	7.781								
42A NEMA 42CZ	42A5	11.3	6.656	4.26	4.25	1.31	.500	[4] 1/4-20 UNC-2B x .31 Min. Deep on 3.75 B.C.	Flat/Key	Yes	24
	42A7	14.5	7.781								
34B	34B3	6.0	4.043	4.02	—	1.625	.500	[4] 1/4-20 UNC-2B x .31 Min. Deep on 2.75 B.C.	Flat	Yes	12 or 24
	34B4	7.0	4.543								
	34B6	9.0	5.543								

Only the first four characters of the product type are relevant to dimensions

42R | 48R Motor Dimensions

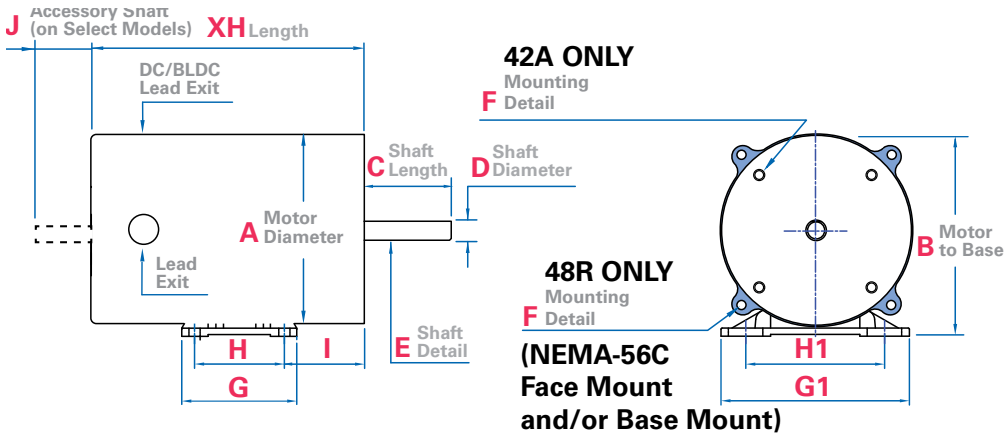

Motor Type 42R, 48R, 42A, pages 21, 23-24 (Base Mount)

	Product Type	Weight (lbs.)	XH Length	A Diameter	B Motor to Base	C Shaft Length	D Shaft Diameter	E Shaft Detail	Face Mount Detail	G Base Length	G1 Base Width	H Mtg. Hole Length	H1 Mtg. Hole Width	I Base Mtg. to Face	J Acc'y Shaft	Lead/Cord Length (in.)
42R	42R3	7.8	5.616	4.73	4.999	1.38	.375	Flat	Base mount 42R motors have no face mounting holes	2.88	4.75	2.25	3.50	1.572	None	12
	42R5	11	6.679													
	42R6	13	7.116													
42R Torque Motor	Model 2628	12.5	6.201	4.62	4.93	1.31	.375	Flat	[4] 1/4-20 UNC-2B x .31 Max. Deep on 3.75 B.C.	2.88	4.75	2.25	3.50	1.569	1.56	12
48R	48R5	17.0	7.329	5.90	5.85	2.06	.625	Key	[4] 3/8-16 UNC-2B x .50 Max. Deep on 5.875 B.C.	3.50	5.75	2.75	4.25	1.446	None	12
	48R6	20.0	7.797													
48R Torque Motor	Model 0632	20.5	6.676	5.73	5.85	2.06	.625	Key	[4] 3/8-16 UNC-2B x .50 Max. Deep on 5.875 B.C.	3.50	5.75	2.75	4.25	1.446	2.00	12
42A	42A5	11.3	6.656	4.26	4.77	1.62	.500	Flat	[4] 1/4-20 UNC-2B x .31 Max. Deep on 3.75 B.C.	2.88	4.75	2.25	3.50	1.471	1.28	24
	42A7	14.5	7.781													

24A Motor Dimensions

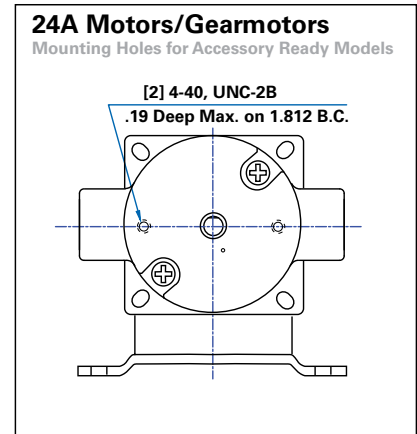
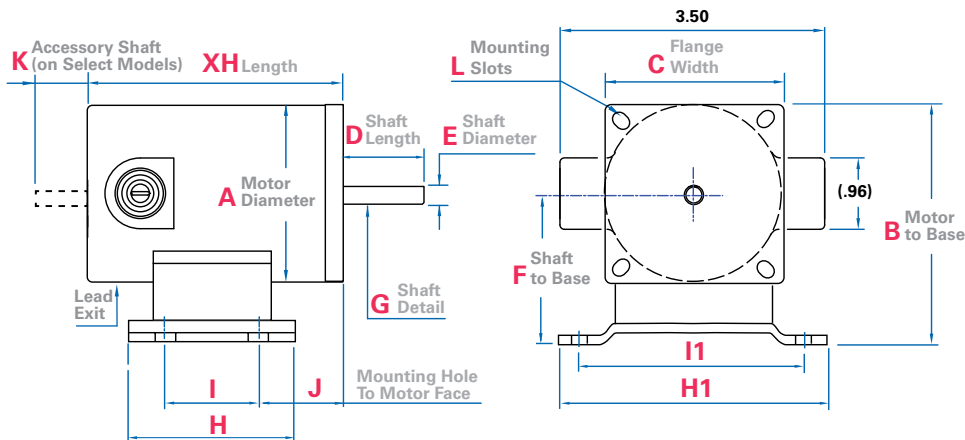

Motor Type 24A, page 24 (Base/Flange Mount)

	Product Type	Wt. (lbs.)	XH Length	A Diameter	B Motor to Base	C Flange Width	D Shaft Length	E Shaft Diameter	F Shaft to Base	G Shaft Detail	H Base Length	H1 Base Width	I Base Mounting Hole Length	I1 Base Mounting Hole Width	J Mounting Hole to Motor Face	K Acc'y Shaft	L Mounting Slots	Lead/Cord Length (in.)
24A	24A0	2.0	3.240	2.42	3.185	2.41	.94	0.312	1.98	Flat	2.25	3.62	1.25	3.00	.625	Yes	0.181W x 0.257L on 2.764 B.C.	24
	24A2	2.5	3.870												1.62			
	24A4	3.0	4.620												1.81			

Only the first four characters of the product type are relevant to dimensions

Chassis Control Dimensions

Dimensions (in inches) are for reference only. For CAD drawings and specs, visit bodine-electric.com.

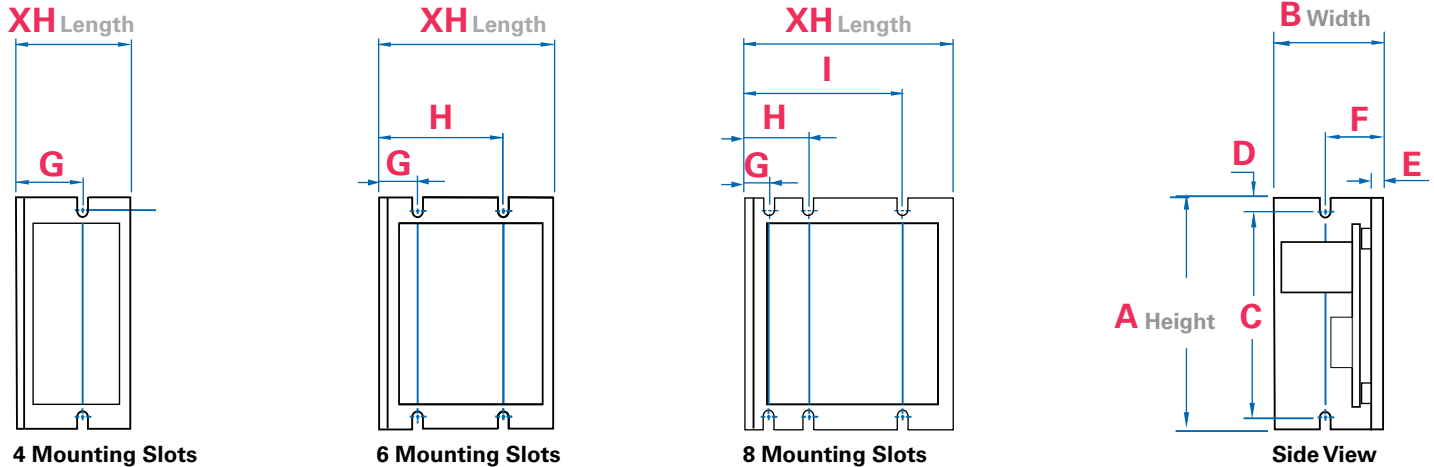

Chassis Models

	Model Number	Description	XH Length	A Height	B Width	C Slot Height	D Slot Center to Edge	E Heat Sink Thickness	F Side Slot to Edge	G Slot 1 to Edge	H Slot 2 to Edge	I Slot 3 to Edge
AC Inverter	2982, 2983, 2984	8 mounting slots	3.87	4.30	2.66	3.80	.25	—	.950	.485	1.235	2.985
	2987	6 mounting slots-no side slots	4.30	4.67	4.96	—	—					
(DC) WPM	see website	6 mounting slots	3.64	4.30	1.75	3.80	.25	.90	.95	.50	3.00	—
(DC) UPM	see website		3.64	4.30	1.50	3.80	.25	.90	.95	.50	3.00	—
(DC) FPM	0810		4.75	6.00	1.25	5.50	.25	—	.94	1.13	3.63	—
(DC) FPM	0830, 0850		5.00	9.25	2.14	8.25	.38	—	—	1.31	3.81	—
(BLDC) ABL	3911, 3921	6 mounting slots	5.50	8.00	2.63	7.50	.25	.188	.117	1.25	42.5	—
(BLDC) ABL	3904, 3905, 3907	4 mounting slots	3.90	8.00	2.25	7.50	.25	.188	1.283	2.25	—	—
Low Voltage	3908, 3909	6 mounting slots	3.25	5.25	1.30	5.05	.10	.125	.65	.75	2.75	—

Enclosed Control Dimensions

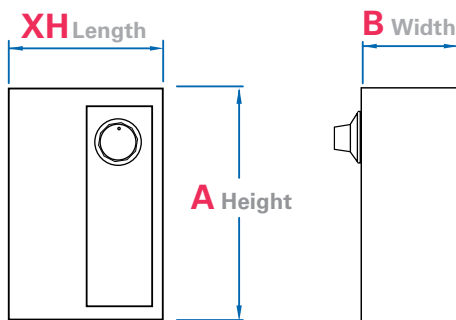

Enclosed Models

	Model Number	Description	XH Length	A Height	B Width
NEMA 4X/1P-65	2999	AC Inverter	5.51	9.53	5.97
NEMA 1/1P-40	2998	AC Inverter	4.95	7.00	4.15
NEMA 1	2996	AC Inverter	7.116	4.96	5.672
NEMA 1	0790, 0791, 0794	DC	7.12	3.92	3.74
NEMA 12	see website	DC/BLDC	6.16	8.44	3.94

Standard products for demanding applications



New SCR rated 90V & 180VDC Gearmotors

With maximum rated armature speed of 2500 rpm, Bodine SCR rated gearmotors provide reliable performance, adjustable speed, and quiet operation. Parallel shaft and right angle gearmotors are available. These stock models can replace 90V or 180VDC gearmotors sold by Baldor, Bison Gear, Leeson, or Grainger.



Variable Speed AC Inverter Duty 3-Phase Gearmotors

Get maintenance-free performance with our inverter duty, three-phase gearmotors. Designed to drive demanding applications like conveyor systems, food processing equipment, medical equipment and factory automation. Parallel shaft, hollow shaft and right-angle gearmotors are rated from 1/25-3/4HP, with gear ratios from 5:1 to 3600:1, and rated torque up to 1000 lb-in (113 Nm). Dual voltage (230/460 VAC) stock models are available.



bodine-electric.com

201 Northfield Road
Northfield, IL 60093
U.S.A.
Tel: 773.478.3515
Fax: 773.478.3232
www.bodine-electric.com
info@bodine-electric.com

Presented by:

