

# Pneumatic Clutches and Brakes

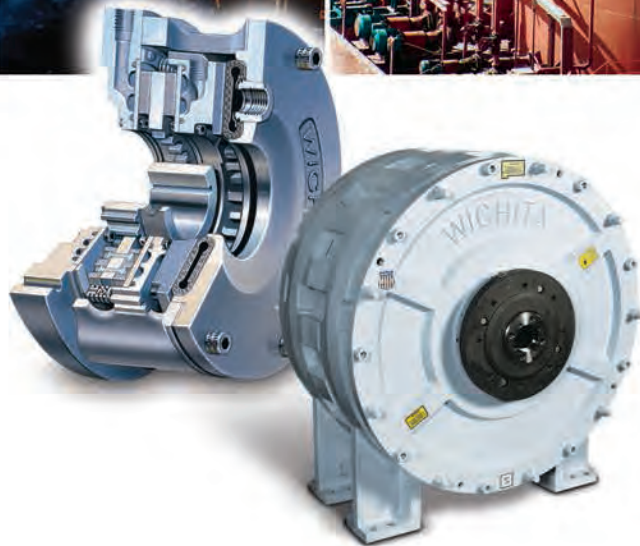

 **Wichita**<sup>®</sup>  
Clutch

An Altra Industrial Motion Company



**DISTRIBUIDOR  
AUTORIZADO**

MEX (55) 53 63 23 31  
QRO (442) 1 95 72 60

MTY (81) 83 54 10 18  
[ventas@industrialmagza.com](mailto:ventas@industrialmagza.com)



## Wichita Clutch

Wichita Clutch designs and manufactures clutches and brakes that are essential in process equipment. Models are available in a variety of designs and mounting configurations and are used extensively around the world by leading OEMs in metalworking, steel, marine, pulp/paper, material handling, paper converting, mining, and energy.

Wichita engineers have extensive application experience and utilize the latest design technologies to provide innovative clutch and brake solutions to precisely meet your most demanding requirements.

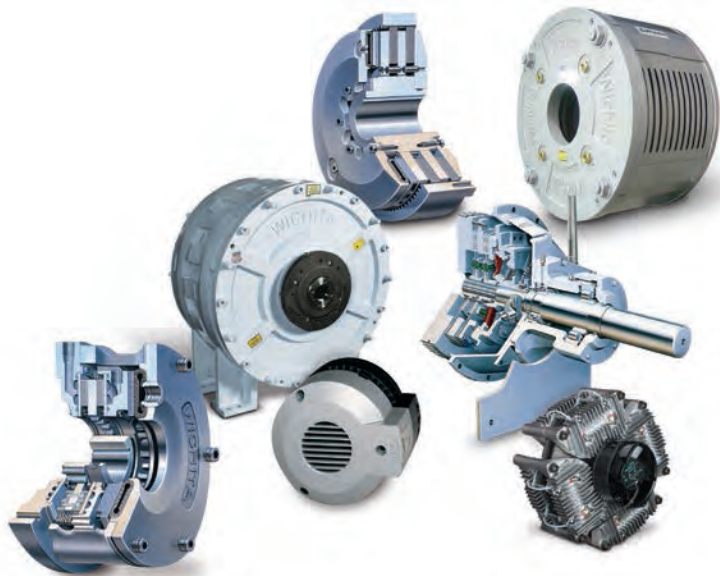

### wichitaclutch.com

Check out [www.wichitaclutch.com](http://www.wichitaclutch.com) for fast and easy access to comprehensive product information. Drop down menus allow you to search by product type, application, or industry. Links to tech sheets for product specifications and dimensions.



## Altra Industrial Motion

Altra is a leading multinational designer, producer and marketer of a wide range of mechanical power transmission products. We sell our products in over 70 countries throughout the world.

Our products are frequently used in critical applications, such as fail-safe brakes for elevators, wheelchairs and forklifts as well as in a wide range of high-volume manufacturing processes, where reliability and accuracy are important for both avoiding costly downtime and enhancing the overall efficiency of manufacturing operations.

Altra products are marketed under a variety of well recognized and established manufacturing brand names including Warner Electric, Boston Gear, TB Wood's, and Formsprag Clutch.

### Genuine Replacement Parts

When you specify genuine replacement parts from Wichita Clutch, you automatically expect more... and get more. Especially better performance, longer life, and the peace of mind that comes with knowing that you are working with the industry's proven leader.



**DISTRIBUIDOR AUTORIZADO** MEX (55) 53 63 23 31 MTY (81) 83 54 10 18  
QRO (442) 1 95 72 60 [ventas@industrialmagza.com](mailto:ventas@industrialmagza.com)

## Dependable Torque Control Products

Wichita clutches and brakes provide the high speed acceleration and deceleration that are essential in modern process equipment. They are available in a variety of designs and mounting configurations and are used extensively around the world by leading OEM's in metalworking, steel, pulp/paper, material handling, paper converting, mining and energy.

Wichita provides custom designs to meet your particular application requirements, giving you the right solution to meet all your power transmission needs.

### General Warnings



Do not repair clutches and brakes (with or without a guard) while they are rotating or with a load engaged.



Do not disassemble while air-tube is pressurized.



Heavy components should be handled carefully. If dropped they can cause serious bodily injury.



Caution, clutches and brakes generate heat. Allow cooling time before normal maintenance.



Do not exceed the recommended maximum air-pressure listed in the Specification Table for each type of unit.



Do not operate clutches and brakes without a guard.



Internal springs under compression. Please refer to installation and maintenance manuals for proper disassembly procedures.



Disable all power sources (electrical, pneumatic, mechanical, etc.) before servicing equipment.



Consult Wichita Installation and Maintenance manuals for proper disassembly and assembly procedures.

Wichita clutches and brakes are designed to be operated with original Wichita replacement parts. Using non-original replacement parts in Wichita clutches and/or brakes voids all warranties issued by Warner Electric LLC. Warner also specifically disclaims any responsibility for damage to persons or property which may be related to the use of said brakes and clutches which employ non-original parts.

Customer Service/Engineering	2
Parts and Service	4
Selection Guide	6
<b>A Combination Clutch/Brakes</b>	<b>10</b>
Applications	11
Size 380 thru 910	14
<b>B Air Tube Disc Clutches and Brakes</b>	<b>22</b>
Applications	22
Low Inertia & Very Low Inertia Clutches & Brakes	24
High Torque Clutches	44
Spring-Set Air Release Brakes	58
<b>C Tension Brakes</b>	<b>70</b>
AquaMaKKs Clutches and Brakes	70
Kopper Kool Brakes	75
Mistral Brakes	102
ModEvo Tension Brakes	106
<b>D Spring-Set Motor Brakes</b>	<b>114</b>
Specifications	115
C-Face Motor Brakes	117
Foot Mounted Motor Brakes	118
<b>E Standard Vent Clutches</b>	<b>122</b>
Applications	123
Coupling Clutches	131
Grinding Mill Clutches	136
<b>F Power Take-Off Clutches</b>	<b>145</b>
Mechanical In-Line PTO	147
Mechanical Side Load PTO	148
Air-Tube Disc Power Take-Off Clutches	151
<b>G Mesur-Fil Fluid Couplings</b>	<b>154</b>
Applications	155
Sizes and Mountings	158
Quick Selection Chart	160
Slip Curves	162
Mesur-Fil Modular Concept Sizes 7.0, 9.4, 12.4	166
Model HC	168
Model HBM	169
Model HCM	170
Model HSD	172
<b>Engineering Data</b>	<b>174</b>
<b>Glossary of Terms</b>	<b>177</b>



# Customer Service



For over 60 years Wichita Clutch has provided engineered solutions to the most demanding torque control problems.

Founded in 1947, Wichita Clutch began manufacturing air-tube disc clutches and brakes. Today, we are recognized as a global leader in heavy-duty power transmission.

## Total Support

Superior customer service is a common denominator at Wichita Clutch. It is this philosophy that places the needs of our customers at the central focus of our efforts. By implementing Cellular Manufacturing, Kan-Ban and Just-In-Time scheduling, our customers receive the products they require precisely when needed. And our computerized order entry systems allow quick and timely answers to your questions. A national distributor network puts local Wichita specialists only a phone call away.

## Assured quality

Wichita Clutch has instituted quality assurance procedures aimed at achieving the ultimate in product reliability. We employ sophisticated Statistical Process Control (SPC) programs to ensure product consistency. Working within our cellular manufacturing structure, every worker is responsible for maintaining unvarying product quality. Our conformity to specifications is your performance guarantee.



*Wichita Clutch Plant  
Wichita Falls, Texas*

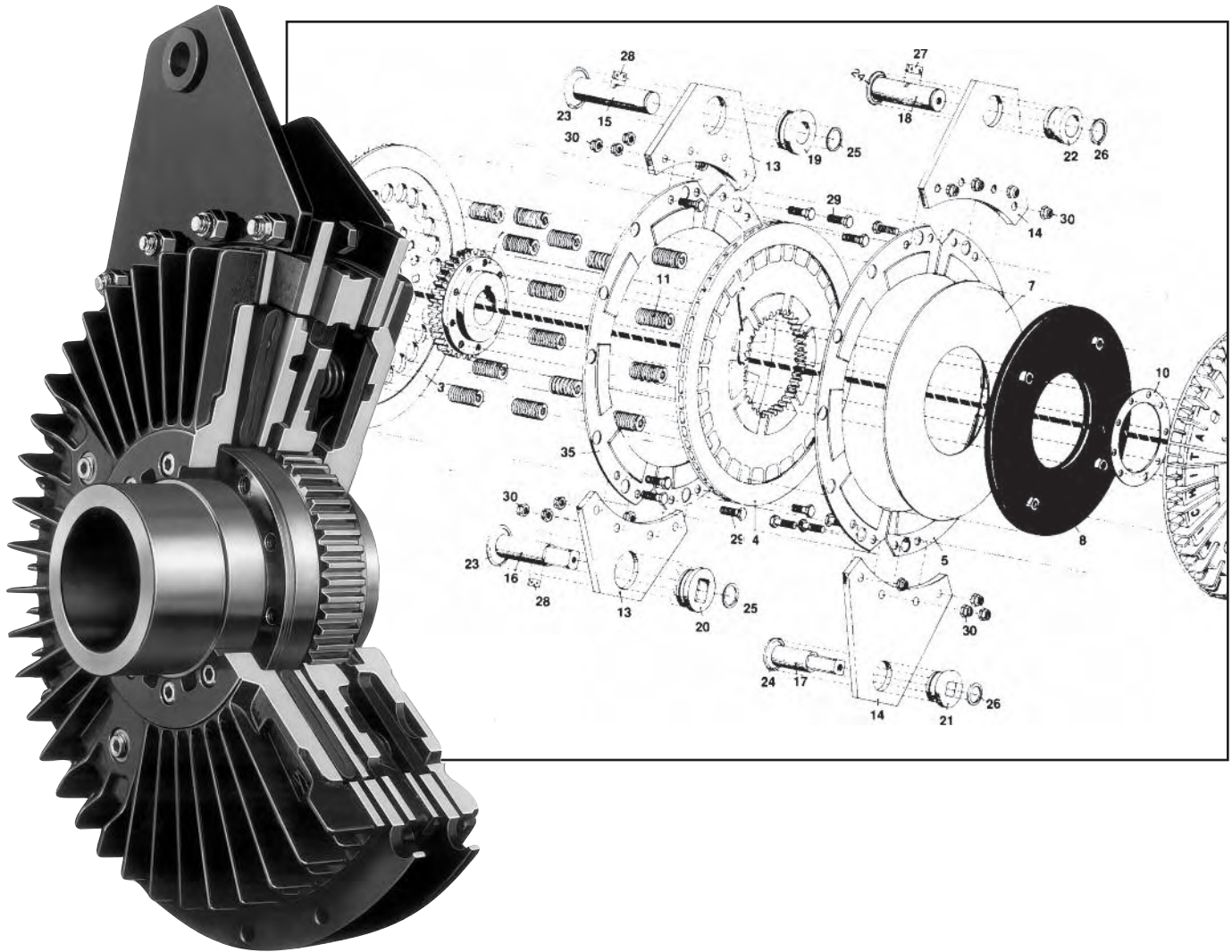

## Engineering

Wichita has dedicated significant resources and talented people to the numerous engineering disciplines required to design, manufacture and apply our heavy duty clutches and brakes. Our application engineers provide timely response to your inquiries with our Computer Aided Product Selection (CAPS) system.

Our product engineers utilize the latest 3-Dimensional CAD equipment in the design of new products. Our dedication to emerging technologies has allowed us to solve the most challenging applications in heavy-duty power transmission.

The simple air-tube disc clutch design allows for greater torque capacity in multiple plate units at less pressure than drum clutch designs. Years of engineering development have produced a variety of designs used extensively by leading OEM's in all major heavy duty applications.





Authorized distributors providing the experience to know just what to replace and how to do it might be the difference between getting your machine up and running fast.

Your application benefits from Wichita research and development and quality control. Consistency in material and quality gives longer life in friction discs and airtubes for replacement peace of mind.

## Genuine Wichita replacement parts

Features no one else can match!

### Friction Discs

Special high strength proprietary materials with molded composite teeth resist functional wear and provide additional output torque.

Friction material provides longer life and more consistent operation due to continuous research and development and quality control.

- Friction disc match exactly the mating Wichita components for consistent and maximum high torque output.
- High strength for dependable, long life service.
- Higher heat resistance to combat unforeseen application problems.
- Consistent size for ease of replacement.
- Wear resistance polymers insure compatibility with other Wichita parts.
- Air grooves to provide cooling and longer life.

### Airtubes

Combination of space age fibers and elastomers give extended life and fit assurance. Wichita airtubes are trouble free and easy to replace. A "Long Stroke" airtube is available on selected models to provide extended service life.

- Controlled quality manufacture insures long life and trouble free service.
- All genuine Wichita Airtubes are trade marked in mold.
- Consistent size allows ease of replacement if required.
- Low air volume construction reduces needless use of compressed air and reduces start/stop times.
- When used in combination with other Wichita parts, the Wichita airtube sustains its heat resistance to insure long operating life in conditions unacceptable to other power transmission devices.

## Comparison Chart

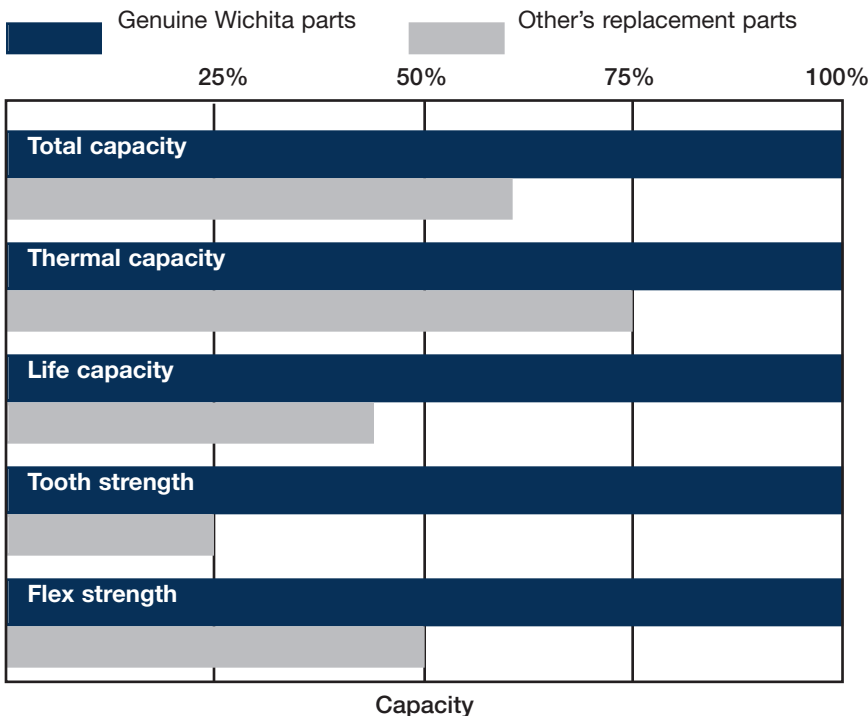

- Wichita split airtubes are available to replace full circle airtubes for emergency operation of needed equipment.
- Wichita maintains a trade mark part number and serial number system molded into the surface of Wichita airtubes for easy identification of genuine Wichita parts.

## Quality Assurance

Continuous Process Improvements through Total Quality Commitment...Computer controlled machining equipment insures precision tolerances for durability and consistent performance.

## Technical Backup

Comprehensive, technical information published on all our products is available to our customers, including complete dimensional drawings, performance curves, exploded part drawings, helpful application engineering data, and complete service/installation manuals. Using genuine Wichita parts assures you of the most knowledgeable technical support in the industry.



## Available Now!

A nationwide network of service oriented, technically trained, authorized Wichita distributors will promptly serve your replacement part needs.

## Your Wichita Distributor

Your Wichita distributor is a power transmission specialist. Because he's your distributor, he has an understanding of your total power transmission system needs. And since he represents Wichita, he can put together the best possible system from the very best components to satisfy your requirements.

Your Wichita distributor, backed by factory regional sales engineers, is near enough to visit your plant to see your problems first hand. He's big enough to find the parts you need on his own shelves, eliminating the time lost while a part is shipped direct. He's experienced enough to make sure the parts he sells are right and perform as promised.

Your Wichita distributor represents your needs to his suppliers. His first commitment is to keep your plant in operation...getting it back in operation as quickly as possible after trouble strikes...maximizing your productivity.

Your Wichita distributor is just as important to Wichita as he is to you. That's why we put a great deal of emphasis on training. His "on-the-spot" knowledge is our assurance that you'll benefit in your plant from all the performance features we build into our products.

## The Wichita difference... local availability

Friction discs and airtubes are available off-the-shelf from Wichita distributors throughout the United States and the rest of the world. Wichita distributors are power transmission specialists offering local stock, local service and local on-the-spot application assistance.

# Selection Guide

## Application Factors

To determine the best Wichita clutch or brake for your application:

- Decide which of the four possible functions you wish to perform.
- Choose the mounting arrangement best suited to your application.
- In the Function/Mounting chart below, choose the proper type of mounting (1,2,3, etc.) to make a preliminary product selection. (Consult your Wichita representative for final product selection.)

Wichita Product	Page No.	Function/Mounting Condition				
		Controlled Acceleration Provide smooth acceleration of a load.	Cycling Accurately positions a load in a repeatable fashion.	Controlled Deceleration Provides a smooth, cushioned deceleration of a load.	Controlled Slip Provide continuous tension to a web or strand.	
					High Heat	Low Heat
Combination Clutch/Brake	10		7, 8, 9			
Very Low Inertia Clutch or Brake	24	1, 2	1, 2	1, 2, 3		1, 2, 3
Low Inertia Clutch or Brake	24	1, 2	1, 2	1, 2, 3		1, 2
High Torque Clutch	44		1	1		1
Spring-Set Air Release Brake	58		1, 2, 3	1, 2, 3		
AquaMaKks Clutch or Brake (Tensioning)	70	1, 2, 3	1, 2, 3	1, 2, 3	1, 2, 3	
Kopper Kool Clutch or Brake (Tensioning)	75	1, 2, 3	1, 2, 3	1, 2, 3	1, 2, 3	
Mistral Brake (Tension Brakes)	102					2
ModEvo (Tension Brakes)	106					2, 3
Motor Brakes (Spring-Set Brake)	114			2, 6		
Standard Vent Coupling Clutch	131	3, 4				
Standard Vent Grinding Mill Clutch	136	3, 4				
Power Take-Off Clutch	145	5				
Measu-Fil Couplings	154	1, 2, 4				

## Types of Mounting (see page 7)

- |                         |                                     |  |
|-------------------------|-------------------------------------|--|
| <b>1</b> Indirect Mount | <b>4</b> Shaft-to-Shaft             | <b>7</b> Ring to Extended Pin                  |
| <b>2</b> Direct Mount   | <b>5</b> Engine Mounted             | <b>8</b> Pin to Pin, Ring to Pin, Ring to Ring |
| <b>3</b> Through Shaft  | <b>6</b> Brake Mount Electric Motor | <b>9</b> Pin to Extended Pin                   |



# Selection Guide

## Types of Mounting

**1** Indirect Mount

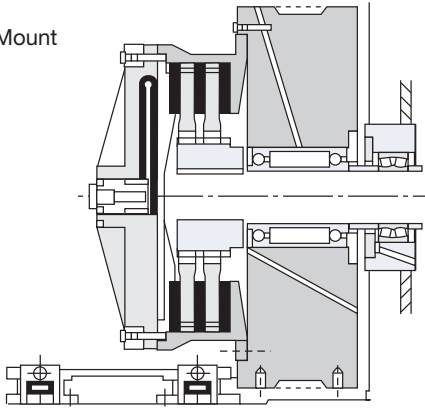

**2** Direct Mount

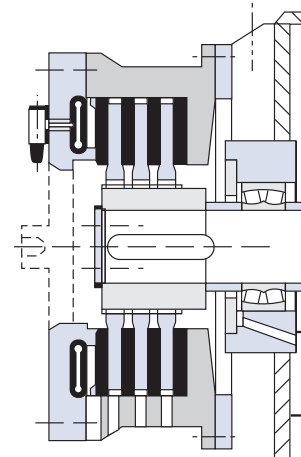

**3** Through Shaft, Inboard Mount Clutch

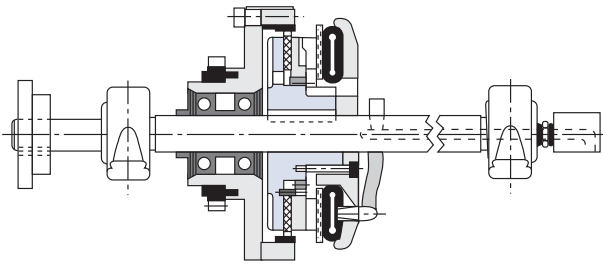

**4** Shaft-to-Shaft In-line (clutch-coupling)

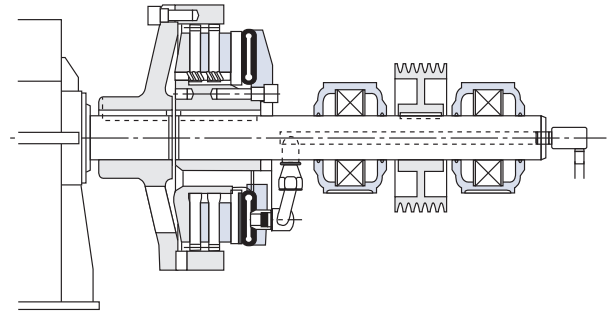

**5** Engine Mount (PTO) Clutch

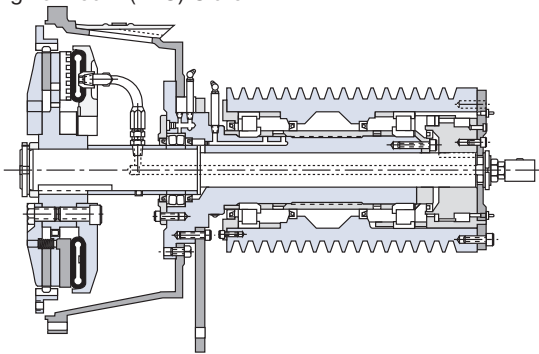

**6** Electric Motor  
C-Face or Foot  
Mount Brake

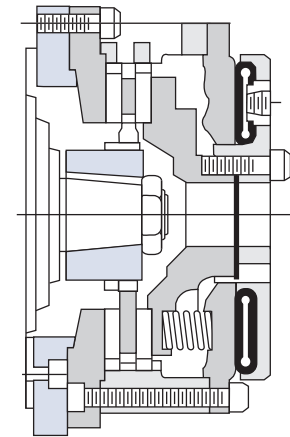

**7** Ring to  
Extended  
Pin

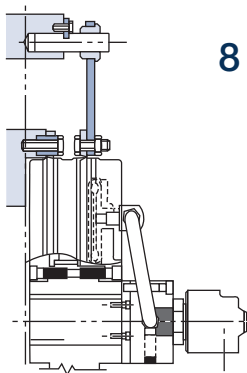

**8** Pin to Pin,  
Ring to Pin,  
Ring to Ring

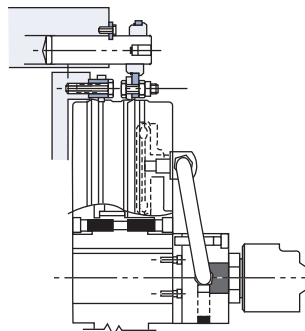

**9** Pin to  
Extended  
Pin

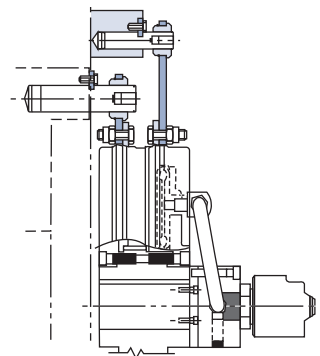

Pneumatic Combination Clutch Brake

# Selection Guide

## Application Factors

Clutch/Brake sizes are affected by the following variables:

1. Machines that operate under smooth loads require smaller clutch/brakes. These machines are driven by either multi-cylinder high speed engines or electric motors with reduced starting current.
2. Drives that require high starting current motors will require clutch/brakes with sufficient torque to prevent excessive slipping while starting.
3. Starting torque may be high, which requires a fast clutch/brake response time to transmit the required torque; or, extended clutch/brake slip time is required to protect the prime mover.
4. Starting torques may be very low compared to the normal torque which may result in the clutch/brake not being fully pressurized prior to the time of torque requirement. This will cause the clutch/brake to over heat from slippage. Clutch/brake inflation time in this instance is very important.
5. Clutch/brakes on most machines are designed to slip prior to damage from shockloads. As a result, the clutch/brake may require periodic maintenance; therefore the clutch/brake should be located in the power train for easy access. Clutch/brakes should also be located for maximum cooling air. In instances where this is not possible, forced air cooling may be desirable to extend clutch/brake life.
6. Safe operating speeds for clutch/brakes should be maintained in design. The following material specifications are recommended for safe operation. The maximum speeds shown are safe operating speeds based upon years of Wichita experience.

Maximum Clutch/Brake Contact Velocity FPM	Material
6,000 (Recommended upper limit for slip) . . . . .	cast iron
9,000 . . . . .	ductile iron
12,000 . . . . .	steel

Dynamic balancing recommended when peripheral speeds exceed 3500 FPM. These velocities are measured at the nominal outside diameter of the clutch/brake plate.

Field of Application	Machine or Equipment	Wichita Product													
		Combination C/B	Air Tube Disc Clutches & Brakes				Tension Brakes				Spring-Set Motor Brakes	Standard Vent Clutches		Power Take-Off	Mesur-Fil Couplings
			Very Low Inertia	Low Inertia	High Torque	Spring-Set	AquaMaKks	Kopper Kool	Mistral	ModEvo		Coupling	Ball Mill		
Air Movement Pumps	Centrifugal compressors		•	•								•			
	Reciprocating compressors (over 2 cylinders)		•	•					•			•			
	Reciprocating compressors (1 or 2 cylinders)		•	•					•			•			
	Centrifugal fans Blowers		•	•					•			•			•
Agitators	Liquid														
	Semi-solid Solids		•	•					•			•			
Brick manufacturing	Brick press	•	•		•							•			
	Extruder Pug mill		•	•								•			
Canning & bottling machine	Bottle-can feeders	•	•	•											
	Filling Mixers		•	•								•			•

# Selection Guide

Field of Application	Machine or Equipment	Wichita Product														
		Combination C/B	Air Tube Disc Clutches & Brakes				Tension Brakes				Spring-Set Motor Brakes	Standard Vent Clutches		Power Take-Off	Mesur-Fil Couplings	
			Very Low Inertia	Low Inertia	High Torque	Spring-Set	AquaMakks	Kopper Kool	Mistral	ModEvo		Coupling	Ball Mill			
Engine driven equipment	Crane		•		•							•	•			
	Hoist		•										•			
	Engine														•	
	Crowd		•										•			
Grinding mills	Ball-rod-sag-pebble														•	
	Crushers														•	
	Shakers														•	
Lumber processing	Yarder		•	•	•		•	•	•							
	Carriages, conveyers		•	•	•		•	•	•							•
	Chipper, logger															
Marine	Propulsion clutch CP wheel			•									•			
	Shaft brakes			•									•			
	Propulsion reversing type			•									•			
	Anchor winch			•									•			
Bulk material handling	Conveyors evenly loaded	•	•	•	•								•			•
	Line shaft evenly loaded		•	•	•								•			
	Feeders		•	•	•								•			
	Elevators		•	•	•								•			
Metal production & metalforming	Coilers		•	•			•	•	•				•			
	Slitters	•	•	•	•	•	•	•	•				•			
	Press brake	•	•	•	•	•			•				•			
	Non-geared press	•	•	•	•	•			•				•			
	Geared press	•	•	•	•	•			•				•			
	Draw bench		•	•		•							•			
	Rolling mill		•	•									•			
	Shear	•	•	•	•	•			•				•			
	Back geared press	•	•	•	•	•			•				•			
	Hammer Mill		•		•								•			
	Forging		•		•								•			
Paper industry dryer sections & calenders, consult factory	Fourdrinier to 500 FPM															
	Fourdrinier to 1800 RPM															
	Paper mill plane															
	Smoothing press			•		•							•			
	Press selections															
	Dryers															
	Calenders															
Petroleum production	Drilling & service rig			•			•	•					•			
	Master clutches			•									•			
	Compound clutches			•									•			
	Rotary Drum			•									•			
	Mud pumps												•			•
	PTO clutches												•			•
Rubber manufacturing	Transfer machines evenly loaded															
	Banberry mixer															
	Drum mixer			•								•				
	Extruder															
	Calender															
	Centrifuge															

# Combination Clutch/Brake

- For metalforming equipment
- Fast, smooth cycling
- Cool running with higher torque
- Compact disc design
- Simple Installation

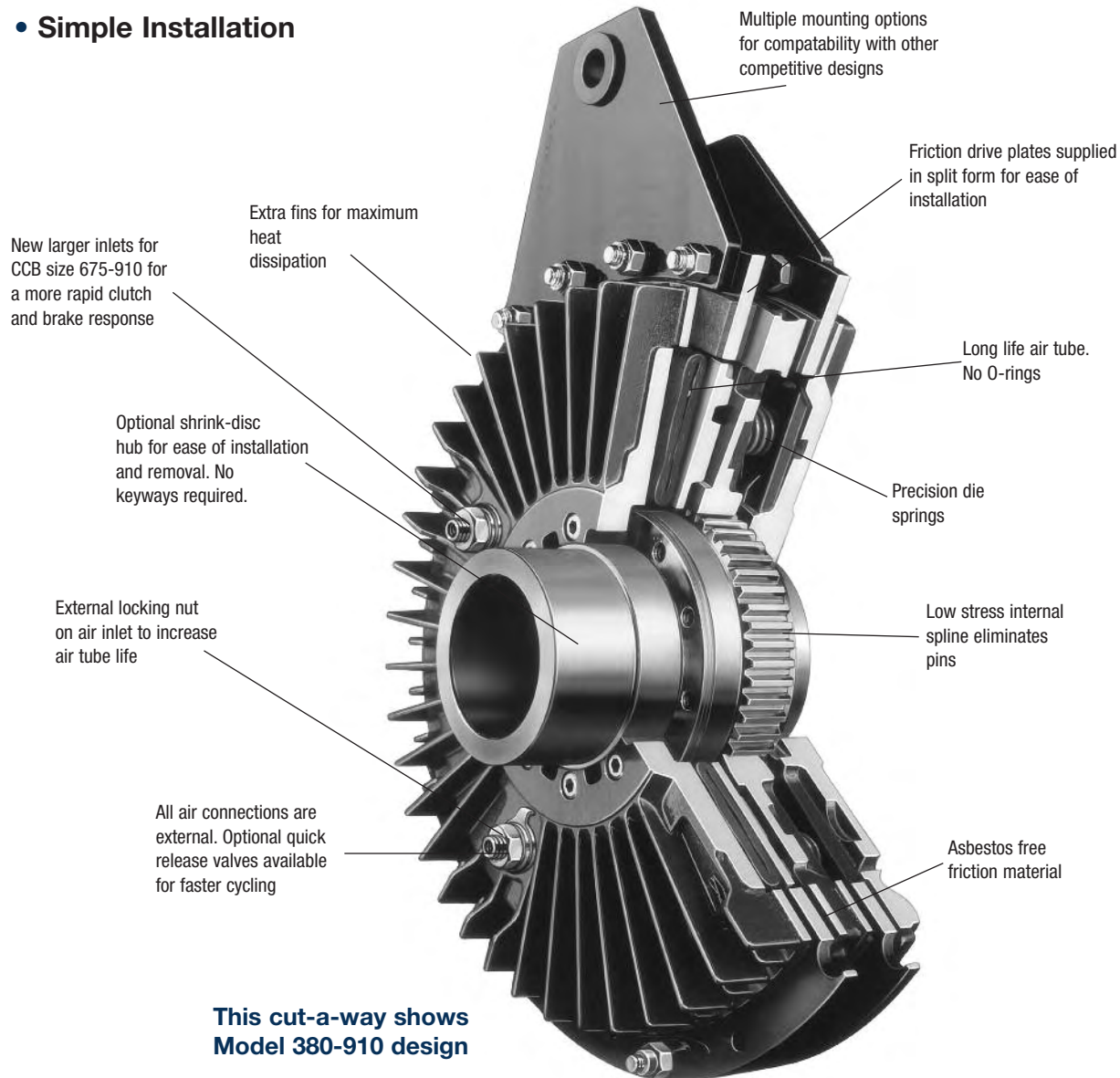

The Wichita Combination Clutch-Brake provides fast, smooth cycling for stamping presses and metalforming equipment. The simple Wichita air tube concept combines an air actuated clutch and a spring-set brake in a compact disc design.

## Design Advantages

- No shaft seals for faster, lower cost installation
- Optional shrink disc mounting for simplified, easier installation
- Cool running for faster cycle rates, higher torques
- Models 380-910 have a single air-tube design that provides long life and high reliability

### Operation

The Wichita Combination Clutch/Brake provides fast, smooth cycling for stamping presses and metalforming equipment.

The simple air-tube concept combines an air actuated clutch and spring-set brake in a compact, pancake assembly that prevents overlap. The extra fins and cooling slots allow for excellent heat dissipation. A low stress spline eliminates driving pins between the shaft and centerplate, while the precision die springs provide consistent long-life braking action.

The high performance air-tube design in sizes 380 and above, with optional quick air-release valves, provides faster cycling than piston and cylinder models. There are no o-rings or piston seals to wear-out and leak, and no lubrication or adjustment is necessary. Worn friction plates can be relined at Wichita's factory on an exchange basis.

Installation of the CCB is also easy. The simple air system has external connections and requires no shaft seals. Metric mounting and SAE fasteners are standard. Available in eight sizes with an optional hub for shrink disc mounting. Clutch capacities through 340,000 lb.in. and brake torque through 250,000 lb.in.

Wichita Combination Clutch/Brakes are manufactured and assembled in the United States and backed by a global sales, service and distributor organization.

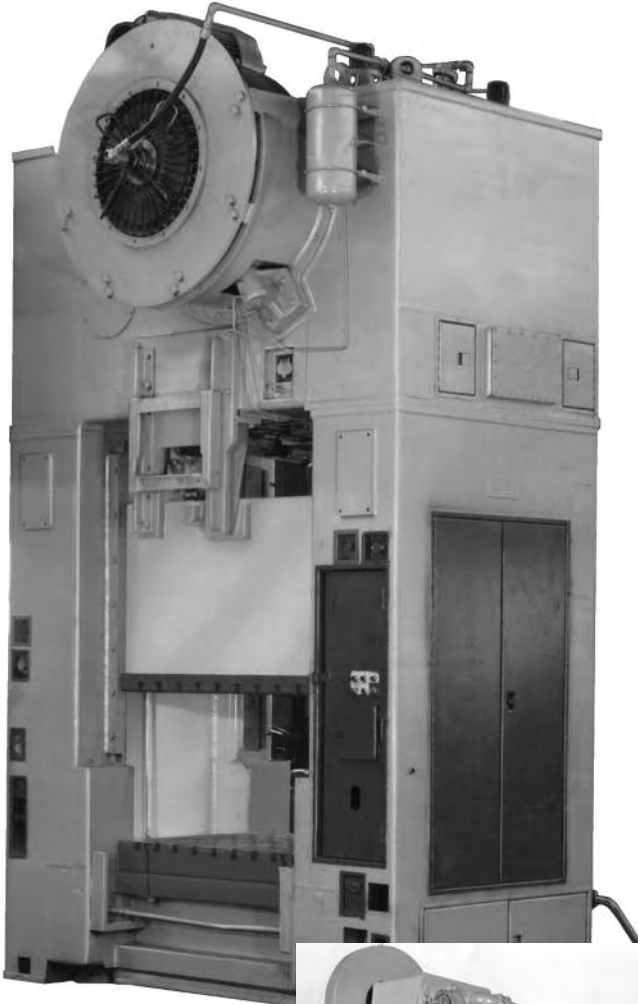

Wichita CCB is ideal for retrofit applications.

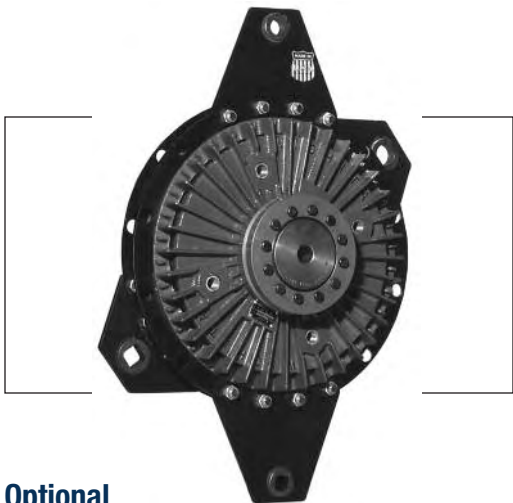

The simple external air system with quick release valves provides smooth, fast cycling.

### Optional

Optional shrink disc hub provides ease of mounting with no keyways.



# Combination Clutch/Brake

## Clutch/Brake Selection

A typical Combination Clutch/Brake application would be on a geared punch press. To properly select a CCB the following application information is needed.

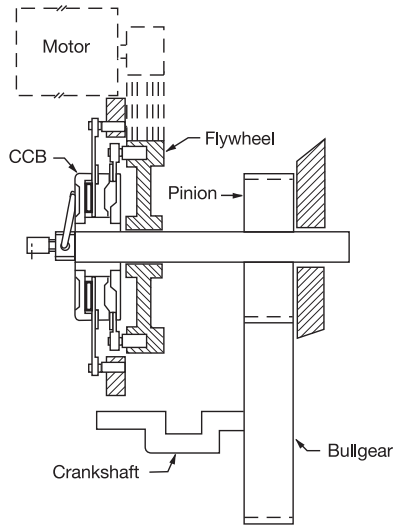

### Application Data

Press Type . . . . . Geared Punch Press  
 Rated Tonnage . . . . . 200 tons  
 Crankshaft Speed . . . . . 30 RPM  
 Degrees of Crank to Start . . . . . 90°  
 Distance Above Bottom - x . . . . . .25 in.  
 1/2 of Press Stroke (throw) = a . . . . . 3 in.  
 WR<sup>2</sup> of Parts on Backshaft . . . . . 78 lb.ft.<sup>2</sup>  
 Required Clutch Torque. . . . . 73,529 lb.in.  
 Stroke . . . . . 6 in.  
 Clutch/Brake Shaft. . . . . 204 RPM  
 Degrees of Crank to Stop. . . . . 120  
 Connecting rod length = b . . . . . 36 in.  
 WR<sup>2</sup> of Parts on Crankshaft . . . . 39,091 lb.ft.<sup>2</sup>  
 Cycles/Minute . . . . . 7  
 Air Pressure Available. . . . . 100 PSI  
 Shaft Size . . . . . 4.5 in.

### Selection

Press clutch and brake selection is based on:

1. Application Duty Factor
2. Application clutch torque
3. Application brake torque necessary to stop
4. Maximum Energy Input
5. Heat generated during cycling
6. Bore size

1. To determine the proper Application Duty Factor for a Geared Punch Press, consult page 16. Under Duty "B" or Normal, the Duty Factor is 1-1/2.

2. To determine the application clutch torque, the following information is needed:

a. Torque @ Crank  
 = (Rated Tonnage) (2000 lb./ton) (Torque Arm)

b. Torque Arm = y = (c) (tan a)

$$c = a + b - x$$

$$= 3 + 36 - .25$$

$$= 38.75 \text{ in.}$$

$$\text{Cos } \alpha = \frac{b^2 + c^2 - a^2}{2bc}$$

$$= \frac{(36)^2 + (38.75)^2 - (3)^2}{(2) (36) (38.75)}$$

$$= .99948$$

$$= 1.8478^\circ$$

c. Torque Arm = y = (c) (tan α)

$$= (38.75) (\tan 1.8478)$$

$$= (38.75) (.03226)$$

$$= 1.25 \text{ in.}$$

Torque @ Crank

$$= (\text{Rate Tonnage}) (2000 \text{ lb./ton})(\text{Torque Arm})$$

$$= (200) (2000) (1.25)$$

$$= 500,000 \text{ lb.in.}$$

Required Torque @ Clutch

$$= \frac{(\text{Torque @ Crank}) \times (\text{Crankshaft RPM})}{\text{Clutch Shaft RPM}} \text{ lb.in.}$$

$$= \frac{(500,000) (30)}{204} \text{ lb.in.}$$

$$= 73,529 \text{ lb.in.}$$

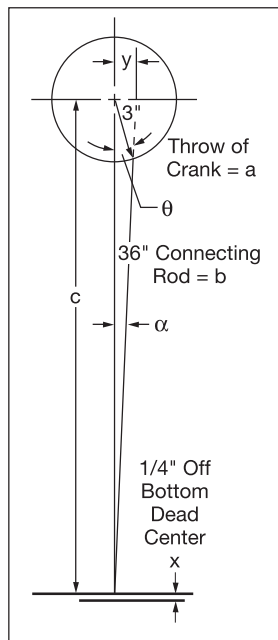

1/4" distance above bottom



Application selection torque = the required torque of 73,529 lb. in. x 1.5 = 110,294 lb.in. (Application Duty Factor for “Geared Punch Press”, page 16.

Preliminary selection of CCB based on clutch torque is the CCB 600 with 50% spring compliment. The clutch torque for this model is 124,350 lb.in. @ 80 PSI.

d. Maximum bore for CCB 600 is 5.0 in. bore acceptable.

3. To determine application brake torque necessary to stop the equipment the following information is needed:

a. The inertia of rotating parts referred to the backshaft. It is given in the application data that the inertia (WR<sup>2</sup>) of parts on the crankshaft is 39,091 lb. ft.<sup>2</sup> at 30 RPM. To calculate WR<sup>2</sup> referred to the backshaft:

$$\left( \frac{30 \text{ RPM of Crankshaft}}{204 \text{ RPM of Backshaft}} \right)^2 \times 39,091 \text{ lb.ft.}^2 = 845 \text{ lb.ft.}^2 @ 204 \text{ RPM}$$

Total WR<sup>2</sup> referred to backshaft is:

$$845 \text{ lb.ft.}^2 + 78 \text{ lb.ft.}^2 = 923 \text{ lb.ft.}^2$$

(WR<sup>2</sup> of parts on backshaft from application data)

Total WR<sup>2</sup> to start and stop is:

$$923 \text{ lb.ft.}^2 + 118 \text{ lb.ft.}^2 = 1041 \text{ lb.ft.}^2$$

(WR<sup>2</sup> of CCB-600 from page 15)

b. The brake stop time required is 120°. (Based on rotation at 30 RPM).

$$\text{Stop Time} = \frac{\text{Angle to Stop}}{360} \times \frac{60}{\text{crankshaft RPM}}$$

$$= \frac{120}{360} \times \frac{60}{30} = .5 \text{ sec.}$$

c. Required deceleration torque =

$$\frac{(WR^2) (\text{CCB RPM})}{(25.6) (\text{Stop Time sec.})} \quad \text{or} \quad \frac{(1041) (204)}{(25.6)(.5)}$$

$$= 16,590 \text{ lb.in.}$$

d. Application brake torque = (18,466) (1.5) or 27,700 lb.in.

The CCB 600 has a rated brake torque capacity of 35,850 lb.in. with 50% spring compliment.

4. Calculate energy input required for the combination clutch/brake.

$$\text{a. Kinetic Energy} = \frac{(WR^2)(\text{CCB RPM})^2}{5,873}$$

$$\text{KE} = \frac{(1041)(204)^2}{5,873} = 7,376 \text{ lbs.ft.}$$

b. Maximum energy input to the CCB 600 is 14,229 ft.lbs. Therefore, CCB 600 has sufficient energy input capacity.

5. To determine the Heat Horsepower Capacity of the CCB at backshaft speed, you need the following information:

a. Heat HP capacity of CCB 600 @ 200 RPM. (Look up capacity under the 200 RPM heading on page 16.)

$$\text{Heat HP} = 3.7 \text{ Heat HP @ 200 RPM.}$$

b. To determine the Cycles Per Minute Capacity, you need the following information:

$$\frac{(\text{Heat HP @ CCB speed}) (1.9 \times 10^8)}{(WR^2) (\text{RPM})^2}$$

$$\text{or} \quad \frac{3.7 (1.9 \times 10^8)}{(1041) (204)^2}$$

$$= 16 \text{ CPM}$$

## Final Selection:

CCB 600 with 1/2 spring compliment. Also available with shrink disc shaft mounting. (See pages 18–19 for various mounting arrangements).

### Note:

This application example is for preliminary sizing only. Contact a Wichita Sales Engineer or the factory for final selection.

# Combination Clutch/Brake

## Specifications

### Size 380 thru 910

CCB Model	Spring Compliment %	Clutch Dynamic Slip Torque Capacity @ 80 PSI**		Brake Dynamic Slip Torque Capacity		Swept Friction Area in. <sup>2</sup> (cm <sup>2</sup> )	Maximum Energy Input lb.ft. (Joules)	Maximum Speed (Balance Speed*) RPM (RPM)
		lb.in.	(Nm)	lb.in.	(Nm)			
380	100%	23,000	(2,600)	18,000	(2,030)	60 (387)	4,640 (6,290)	1,550 (895)
	75%	27,500	(3,100)	13,500	(1,525)			
	50%	32,000	(3,600)	9,000	(1,015)			
	25%	36,500	(4,120)	4,500	(505)			
470	100%	43,400	(4,900)	34,500	(3,890)	120 (774)	9,280 (12,581)	1,250 (725)
	75%	52,000	(5,870)	25,900	(2,920)			
	50%	60,650	(6,845)	17,250	(1,945)			
	25%	69,275	(7,800)	8,625	(975)			
550	100%	68,100	(7,685)	54,000	(6,095)	184 (1,187)	14,229 (19,291)	1,060 (620)
	75%	81,600	(9,210)	40,500	(4,570)			
	50%	95,100	(10,735)	27,000	(3,050)			
	25%	108,600	(12,260)	13,500	(1,525)			
600	100%	88,500	(9,900)	71,700	(8,090)	184 (1,187)	14,229 (19,291)	970 (570)
	75%	106,425	(12,000)	53,775	(6,070)			
	50%	124,350	(14,035)	35,850	(4,045)			
	25%	142,275	(16,060)	17,925	(2,220)			
675	100%	132,000	(14,900)	105,400	(11,910)	308 (1,987)	23,818 (32,291)	860 (500)
	75%	158,350	(17,875)	79,050	(8,930)			
	50%	184,700	(20,845)	52,700	(5,955)			
	25%	211,050	(23,820)	26,350	(2,975)			
760	100%	173,210	(19,570)	156,220	(17,652)	360 (2,323)	27,839 (37,743)	765 (450)
	75%	214,550	(24,240)	117,165	(13,236)			
	50%	255,900	(28,915)	78,110	(8,826)			
	25%	291,115	(32,890)	39,055	(4,415)			
830	100%	254,500	(28,750)	199,000	(22,480)	404 (2,606)	31,241 (42,356)	700 (410)
	75%	309,700	(34,990)	149,300	(16,870)			
	50%	337,300	(38,110)	124,400	(14,055)			
	25%	392,500	(44,345)	74,600	(8,430)			
910	100%	346,800	(39,150)	258,400	(29,160)	462 (2,981)	35,726 (48,437)	640 (375)
	75%	411,400	(46,430)	193,800	(21,870)			
	50%	476,000	(52,725)	129,200	(14,580)			
	25%	540,600	(60,000)	64,600	(7,290)			

Maximum operating pressure is 100 PSI, (7BAR)

\* Operating the unit above the Balance speed to Maximum, it is recommended to have the unit balanced. It is suggested to operate the unit in a continuous running, non-cyclic mode. Operating the unit in a cyclic, single-stroking mode, may result in some dusting of the friction material.

\*\* For dry operation only. It is essential to keep the friction material free of lubricants.

Model Size	Assembly (100% SPR. COMPL)	Drawing Numbers	Part Family
380	7-915-100-209-0000	7-915-100-931-1&2	546
470	7-918-100-205-0000	7-918-100-931-1&2	547
550	7-922-100-209-0000	7-922-100-931-1&2	549
600	7-923-100-209-0000	7-923-100-931-1&2	551
675	7-927-100-209-0000	7-927-100-931-1&2	552
760	7-930-100-209-0000	7-930-100-931-1&2	553
830	7-933-100-209-0000	7-933-100-931-1&2	555
910	7-935-100-209-0000	7-935-100-931-1&2	554



# Combination Clutch/Brake

## Specifications

Size 380 thru 910

### Dimensions: inches (mm)

CCB Model	Maximum Bores			Internal Parts Inertia		'R' External Parts Inertia		Total Weight (RR Style)	
	Square Key in. (mm)	Twin Rect. Keys in. (mm)	Shrink Disc in. (mm)	lb.ft. <sup>2</sup>	(kgm <sup>2</sup> )	lb.ft. <sup>2</sup>	(kgm <sup>2</sup> )	lb.	(kg)
380	2-7/8 (73)	3-3/16 (81)	3-1/8 (80)	12.4	(.52)	4	(0.17)	99	(45)
470	3-3/8 (86)	3-3/4 (95)	4-1/8 (105)	33.3	(1.4)	16	(0.67)	190	(86)
550	4-1/2 (114)	4-3/4 (121)	5-1/2 (140)	70.2	(3.0)	23	(0.97)	290	(132)
600	5 (127)	5 (127)	6-3/32 (155)	118	(5.0)	72	(3.0)	380	(172)
675	5 (127)	5-1/2 (140)	6-3/32 (155)	209	(8.8)	80	(3.4)	530	(240)
760	6-3/10 (160)	6-7/8 (175)	7-7/8 (200)	370	(15.6)	154	(6.5)	760	(345)
830	6-7/8 (175)	7-1/2 (191)	8-15/32 (215)	455	(19.2)	226	(9.5)	635	(288)
910	7-1/8 (181)	8-3/8 (213)	9-1/4 (235)	820	(34.5)	280	(11.8)	1,190	(540)

# Combination Clutch/Brake

## Application Duty Factors

Field of Application	Duty B Normal – Factor 1-1/2	Duty C Heavy – Factor 3-1/4	Duty D Extra Heavy – Factor 5-1/2
Metal Production & Forming	Press Brake	Shear	Forming Press
	Non-Geared Punch Press Flywheel Drive*	Back Geared Punch Press Double Back Shaft Drive*	Forging Press Header Press
	Geared Punch Press Single Back Shaft Drive*	Deep Draw Press	Knuckle Press
	Single Reduction Drive*	Transfer Press	
	Single Gear Drive*	Toggle Press	

\* Alternate common industry name for above machine type

## Heat Horsepower Capacity

CCB	Speed – RPM								
	100	200	300	400	500	600	700	800	900
170	.12	.16	.20	.23	.25	.27	.28	.30	.31
190	.16	.21	.25	.28	.30	.32	.34	.35	.36
230	.28	.35	.42	.45	.48	.51	.54	.58	.61
310	.51	.63	.74	.84	.93	.98	1	1.07	1.12
380	1	1.3	1.6	1.8	1.9	2	2	2.4	2.7
470	1.7	2.1	2.4	2.8	3.1	3.4	3.6	3.9	4.2
550	2.5	3.0	3.5	3.9	4.3	4.7	5.1	5.6	6
600	3	3.7	4.3	4.9	5.5	5.9	6.2	6.6	7
675	3.7	4.4	5	5.8	6.5	7.1	7.6	8.1	*
760	5	6.1	7.1	7.7	8.3	8.9	9.5	*	*
830	6.5	7.9	9.3	10.2	11.1	11.9	12.7	*	*
* Beyond maximum speed limit									
910	8	9.8	11.5	12.8	14	15.2	*	*	*

# Combination Clutch/Brake

## Component Parts

Size 380 thru 910

A

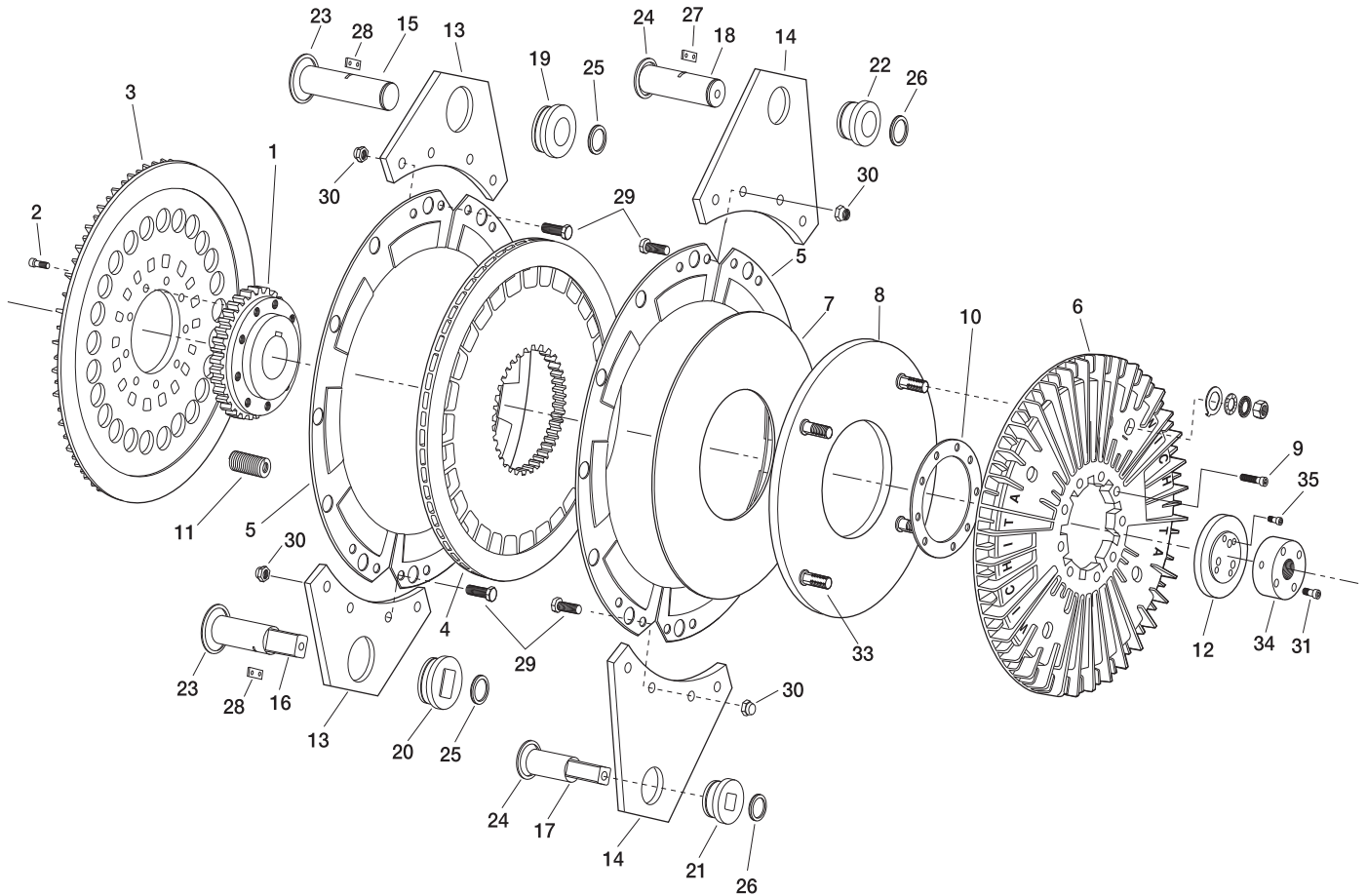

- |                                 |                                       |  |
|---------------------------------|---------------------------------------|--|
| 1. Hub                          | 15. Drive Pin (Round Clutch)          | 29. Hex Head Capscrew (HHCS)                         |
| 2. Bolt                         | 16. Drive Pin (Square Clutch)         | 30. Flex Lock Nuts                                   |
| 3. Back Plate                   | 17. Drive Pin (Square Brake)          | 31. Socket Head Capscrew (SHCS)                      |
| 4. Center Plate                 | 18. Drive Pin (Round Brake)           | 33. Air Spud   |
| 5. Drive Plate                  | 19. Drive Bushing (Round Clutch)      | 34. Air Manifold                                     |
| 6. Air-Tube Holding Plate       | 20. Drive Bushing (Square Clutch)     | 35. Socket Head Capscrew (SHCS)                      |
| 7. Pressure Plate               | 21. Drive Bushing (Square Brake)      |  |
| 8. Air-Tube                     | 22. Drive Bushing (Round Brake)       | Not Shown:   |
| 9. Air-Tube Holding Plate Bolts | 23. Snap Ring                         | • Bolt & Nut between Pressure Plate and Center Plate |
| 10. Shim                        | 24. Snap Ring                         | • Clip, Bolt & Nut on Ring Mount                     |
| 11. Brake Springs               | 25. Snap Ring                         |  |
| 12. End Cap                     | 26. Snap Ring                         |  |
| 13. Short Mounting Bracket      | 27. Retainer Plate (Brake Drive Pin)  |  |
| 14. Long Mounting Bracket       | 28. Retainer Plate (Clutch Drive Pin) |  |



# Combination Clutch/Brake

## Component Parts

Size 380 thru 910

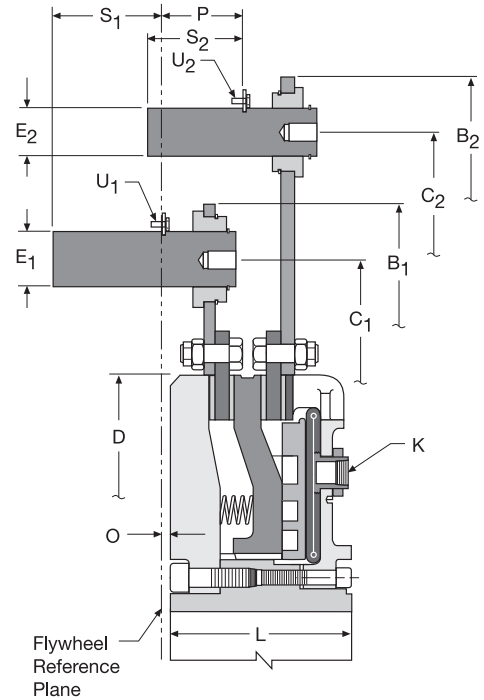
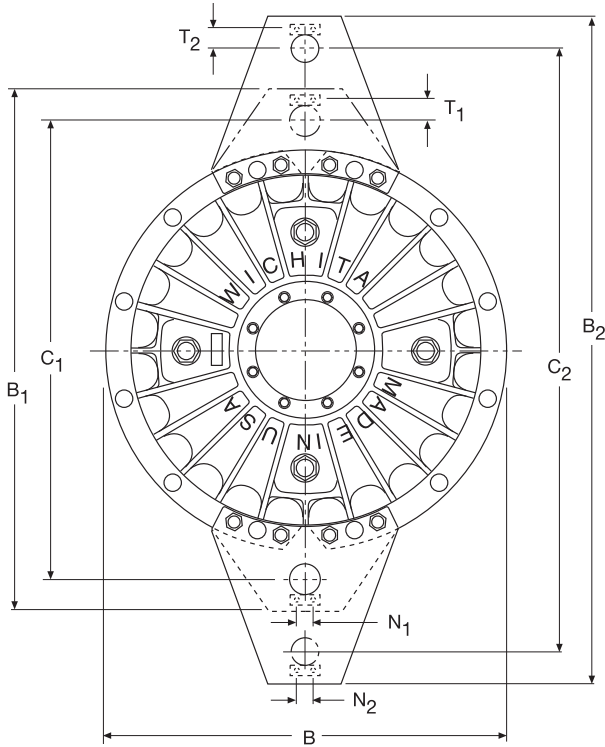

**PEP**

**(Pin to Extended Pin)**

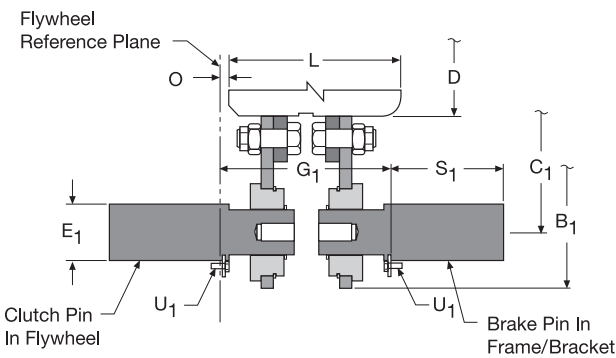

**PP**

**(Pin to Pin)**

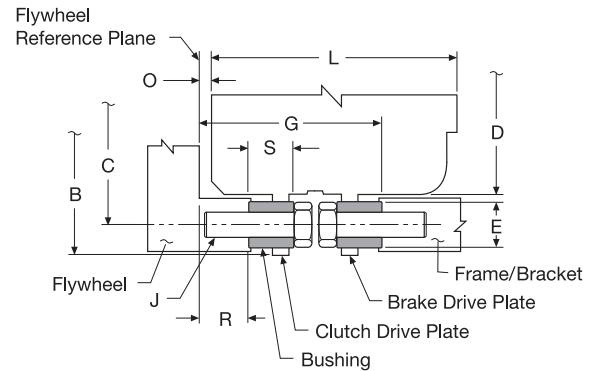

**RR**

**(Ring to Ring)**

**RP (Ring to Pin)**

**RR (Ring to Ring)\***

**PP (Pin to Pin)\***

\* Dimensions same as RP design  
All ring drives to have pins located  
in pin size counterbores 0.13" deep.

# Combination Clutch/Brake

## Component Parts

Size 380 thru 910

### Dimensions: inches (mm)

Model No.	A Max. Bore*	C, C <sub>1</sub> , C <sub>2</sub> dimensions are ± .007 (.18)										G RR	G <sub>1</sub> PP
		B	B <sub>1</sub>	B <sub>2</sub>	C	C <sub>1</sub>	C <sub>2</sub>	D	E +.000/-0.002	E <sub>1</sub> +.001/-0.000	E <sub>2</sub> +.001/-0.000		
380	2.875 (73)	17.13 (435)	22.05 (560)	26.77 (680)	16.063 (408)	19.488 (495)	25.000 (635)	14.94 (380)	0.709 (18)	1.181 (30)	0.866 (22)	3.24 (82.2)	4.32 (109.7)
470	3.375 (86)	21.06 (535)	27.36 (695)	33.66 (855)	19.685 (500)	24.016 (610)	31.102 (790)	18.50 (470)	0.984 (25)	1.575 (40)	1.181 (30)	4.02 (102.1)	4.88 (124.0)
550	4.500 (114)	24.41 (620)	30.71 (780)	37.40 (950)	22.992 (584)	27.362 (695)	34.843 (885)	21.65 (550)	0.984 (25)	1.575 (40)	1.181 (30)	5.06 (128.4)	6.42 (163.1)
600	5.000 (127)	26.77 (680)	34.25 (870)	42.32 (1,075)	25.197 (640)	30.315 (770)	38.976 (990)	23.62 (600)	1.181 (30)	1.772 (45)	1.575 (40)	4.83 (122.6)	6.22 (158.0)
675	5.000 (127)	30.51 (775)	39.37 (1,000)	48.56 (1,235)	28.543 (725)	34.646 (880)	44.685 (1,135)	26.57 (675)	1.378 (35)	2.165 (55)	1.772 (45)	5.39 (136.9)	6.98 (177.3)
760	6.300 (160)	34.06 (865)	42.91 (1,090)	52.56 (1,335)	31.890 (810)	38.189 (970)	48.622 (1,235)	29.92 (760)	1.575 (40)	2.165 (55)	1.772 (45)	5.96 (151.4)	7.50 (190.5)
830	6.875 (175)	37.50 (953)	49.31 (1,252)	63.09 (1,602)	—	43.307 (1,100)	57.087 (1,450)	32.68 (830)	1.772 (45)	2.954 (75)	2.560 (65)	7.19 (182.6)	8.75 (222.3)
910	7.125 (181)	40.35 (1,025)	52.76 (1,340)	65.75 (1,670)	37.992 (965)	46.457 (1,180)	60.039 (1,525)	35.82 (910)	1.772 (45)	2.953 (75)	2.559 (65)	7.43 (188.7)	9.61 (244.1)

### Dimensions: inches (mm)

Model No.	Qty.	K Size	Lengths											Thread		
			L	N <sub>1</sub>	N <sub>2</sub>	O	P	R	S	S <sub>1</sub>	S <sub>2</sub>	T <sub>1</sub>	T <sub>2</sub>	J	U <sub>1</sub>	U <sub>2</sub>
380	4	1/2" NPT	4.41 (112)	1.00 (25)	1.00 (25)	0.47 (12)	2.05 (52.0)	0.96 (45.5)	0.75 (19)	2.36 (60)	1.77 (45)	0.79 (20)	0.63 (16)	3/8-16 NC	#10-24 NC	#10-24 NC
470	4	1/2" NPT	5.50 (140)	1.378 (35)	1.00 (25)	0.41 (10.5)	2.60 (66.5)	1.12 (28.5)	0.87 (22)	3.15 (80)	2.36 (60)	1.06 (27)	0.79 (20)	1/2-13 NC	1/4-20 NC	#10-24 NC
550	4	1/2" NPT	6.30 (160)	1.378 (35)	0.984 (25)	0.51 (13.0)	3.17 (80.5)	1.34 (34)	1.18 (30)	3.15 (80)	2.36 (60)	1.06 (27)	0.79 (20)	1/2-13 NC	1/4-20 NC	#10-24 NC
600	4	1/2" NPT	7.28 (185)	1.378 (35)	1.378 (35)	0.49 (12.5)	3.19 (81.0)	1.32 (33.5)	1.06 (27)	3.54 (90)	3.15 (80)	1.16 (29.5)	1.06 (27)	5/8-11 NC	5/16-18 NC	1/4-20 NC
675	4	1" NPT	8.00 (203)	1.772 (45)	1.378 (35)	0.49 (12.5)	3.88 (98.5)	1.42 (36)	1.25 (32)	4.33 (110)	3.54 (90)	1.52 (38.5)	1.16 (29.5)	3/4-10 NC	5/16-18 NC	1/4-20 NC
760	4	1" NPT	9.06 (230)	1.772 (45)	1.378 (35)	0.49 (12.5)	4.23 (107.5)	1.59 (40.5)	1.50 (38)	4.33 (110)	3.54 (90)	1.52 (38.5)	1.16 (29.5)	7/8-9 NC	5/16-18 NC	1/4-20 NC
830	4	1" NPT	8.00 (203)	1.75 (45)	1.75 (45)	0.50 (12.7)	4.32 (109.7)	1.94 (49.3)	1.75 (44.5)	5.91 (150.1)	5.12 (130)	1.71 (43.5)	1.71 (43.5)	1-8 NC	5/16-18 NC	5/16-18 NC
910	3	1" NPT	10.24 (260)	2.362 (60)	1.772 (45)	0.89 (22.5)	4.90 (124.5)	2.10 (53.5)	1.75 (44.5)	5.91 (150)	5.12 (130)	2.07 (52.5)	1.71 (43.5)	1-8 NC	3/8-16 NC	5/16-18 NC

\* Maximum bores with square key. Larger bores available with shallow keys.

Note: For mounting, use socket head capscrews conforming to the ASTM-574-97a.

# Combination Clutch/Brake

## End Cap Air Manifold

Model	Kit No.	A	B	C	D	E	F
380	8-546-021-000-1	4.188	3.12	N/A	.875 H.C. 13/32 Drill 3 at 120°	1/2" NPT 4 at 90°	1"-14 NF
470	8-547-021-000-1	4.188	3.12	N/A	1.250 H.C. 13/32 Drill 3 at 120°	1/2" NPT 4 at 90°	1"-14 NF
550	8-549-021-000-1	4.937 / 4.935	3.12	3.000 H.C. 13/32 Drill 3 at 120°	2.000 H.C. 13/32 Drill 3 at 120°	1/2" NPT 4 at 90°	1-1/2"-12 NF
600	8-552-021-000-1	4.938	3.12	2.875 H.C. 13/32 Drill 3 at 120°	N/A	1/2" NPT 4 at 90°	1-1/2"-12 NF
675	8-552-021-000-1	4.938	3.12	2.875 H.C. 13/32 Drill 3 at 120°	N/A	1/2" NPT 4 at 90°	1-1/2"-12 NF
760	8-553-021-000-1	7.000	3.12	N/A	3.500 H.C. 13/32 Drill 3 at 120°	1/2" NPT 4 at 90°	1-1/2"-12 NF
830	4-555-021-000-3	9.50	4.06	N/A	4.000 H.C. 9/16 Drill 4 at 90°	1" NPT 4 at 90°	1-1/2"-12 NF
910	8-554-021-000-1	7.255 / 7.250	3.12	5.000 H.C. 17/32 Drill 3 at 120°	3.250 H.C. 17/32 Drill 3 at 120°	1/2" NPT 6 at 60°	2"-12 NF

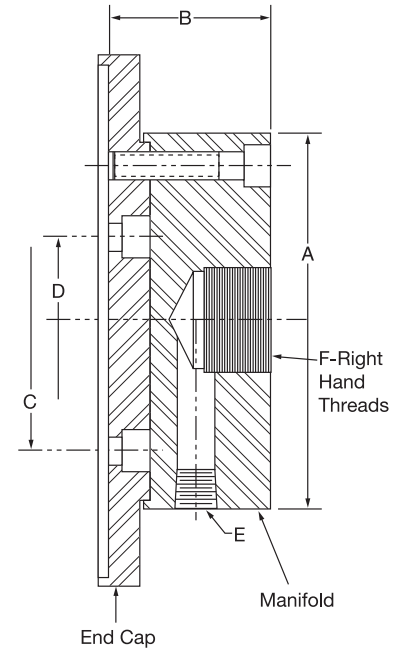

## Clearance & Wear Chart

Model	Minimum Clearance		W+	Maximum	Wear	Tank Vol.	Pipe Size	Roto-Coupling* Part No.				
	in.	(mm)							in.	(mm)	in. <sup>3</sup>	liters
380	1/32	(0.8)	0.1	(2.5)	86	0.12	(3)	100	1.6	3/4	(19)	8-240-708-001-1
470	1/32	(0.8)	0.1	(2.5)	134	0.16	(4)	155	2.5	3/4	(19)	8-240-708-001-1
550	3/64	(1.2)	0.11	(2.8)	196	0.20	(5)	250	4.1	1	(32)	8-240-710-002-1
600	3/64	(1.2)	0.11	(2.8)	215	0.20	(5)	275	4.5	1	(32)	8-240-710-002-1
675	1/16	(1.6)	0.12	(3.2)	280	0.25	(6)	390	6.4	1	(32)	8-240-710-002-1
760	1/16	(1.6)	0.12	(3.2)	360	0.25	(6)	500	8.2	1	(32)	8-240-710-002-1
830	3/32	(2.4)	0.16	(4)	489	0.25	(6)	800	13.1	1-1/2	(38)	8-240-710-002-1
910	3/32	(2.4)	0.16	(4)	530	0.28	(7)	1000	16.4	1-1/2	(38)	8-240-712-001-1

\*See page 35 for dimensions



# Combination Clutch/Brake

## Air Hose Kits Sizes 380 thru 910

A

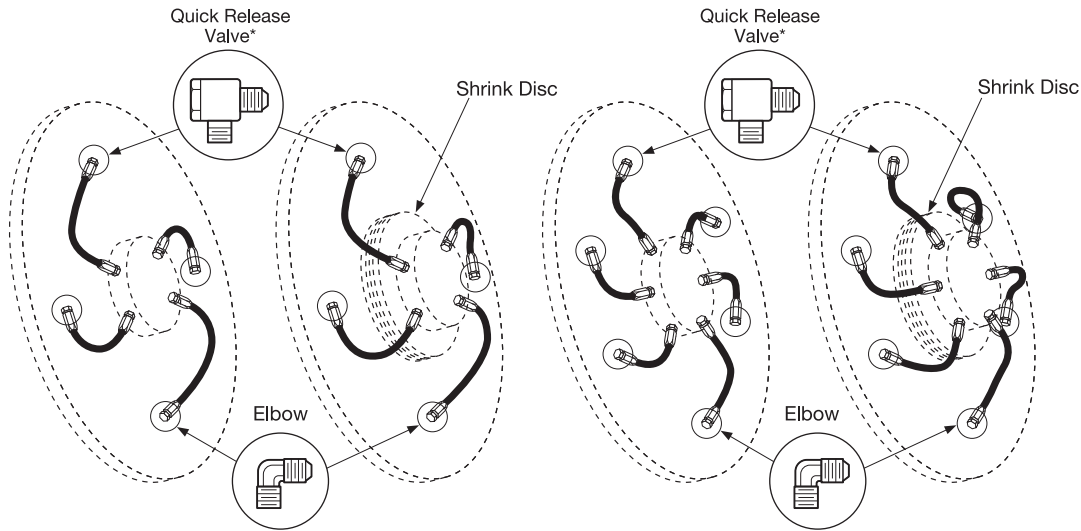

\* Optional Quick Release Valves can replace elbows on most units.

Hose Kit for Air Manifold or Cross Drilled Shaft Mounting	
Model	Part Number
380	8-938-812-402-5 ELB 8-938-820-401-5 QRV
470	8-947-812-402-5 ELB 8-947-820-401-5 QRV
550	8-955-812-402-5 ELB 8-955-820-401-5 QRV
600	8-960-812-402-5 ELB 8-960-820-401-5 QRV
675	8-967-812-402-5 ELB 8-967-820-401-5 QRV
760	8-976-812-402-5 ELB 8-976-820-401-5 QRV
830	8-983-813-401-5 ELB 8-983-831-401-5 QRV

Hose Kit for Shrink Disc Mid-Shaft Mounting	
Model	Part Number
380	8-938-812-401-5 ELB 8-938-822-401-5 QRV
470	8-947-812-401-5 ELB 8-947-822-401-5 QRV
550	8-955-812-401-5 ELB 8-955-822-401-5 QRV
600	8-960-812-401-5 ELB 8-960-822-401-5 QRV
675	8-967-812-401-5 ELB 8-967-822-401-5 QRV
760	8-976-812-401-5 ELB 8-976-822-401-5 QRV
830	8-983-813-402-5 ELB 8-983-831-402-5 QRV

Hose Kit for Air Manifold or Cross Drilled Shaft Mounting	
Model	Part Number
910	8-991-812-502-5 ELB 8-991-820-501-5 QRV

Hose Kit for Shrink Disc Mid-Shaft Mounting	
Model	Part Number
910	8-991-812-503-5 ELB 8-991-822-503-5 QRV

Wichita Air Hose Kits contain all the necessary parts (fittings, hoses and extensions) to completely plumb the brake air system. The Hose Kit part number is determined by model number, type of shaft mounting and whether or not a quick release valve is needed.

Muffler Part Number: 4-263-605-002-0



# Air Tube Disc Clutches and Brakes

## Typical Applications

Wichita High Torque Clutch provides fast acceleration and long life on metalforming punch presses.

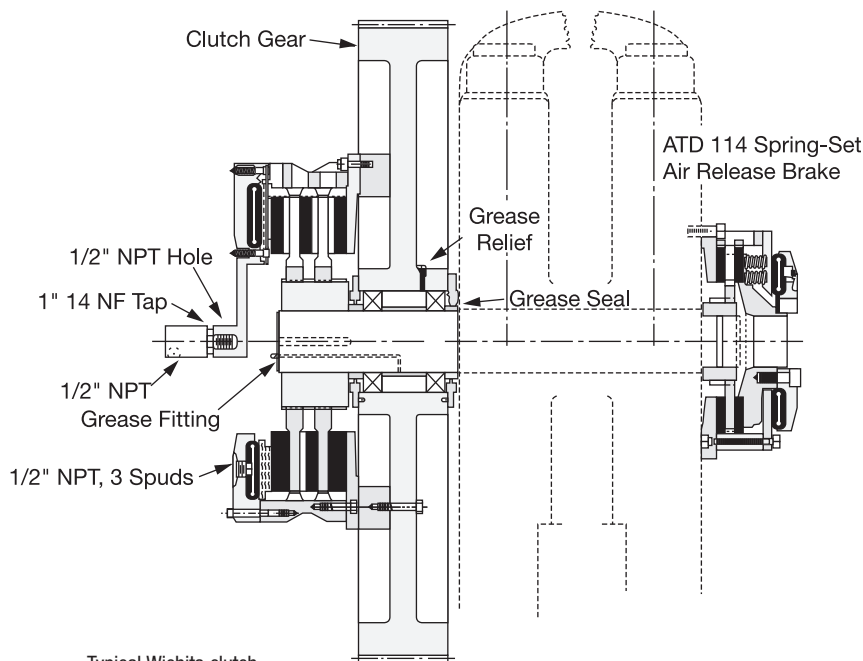
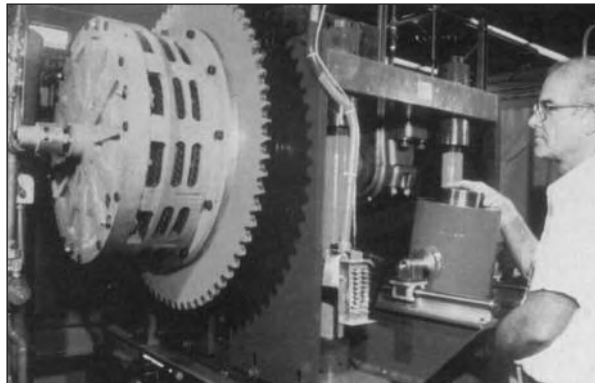

Typical Wichita clutch and brake mounting on a press

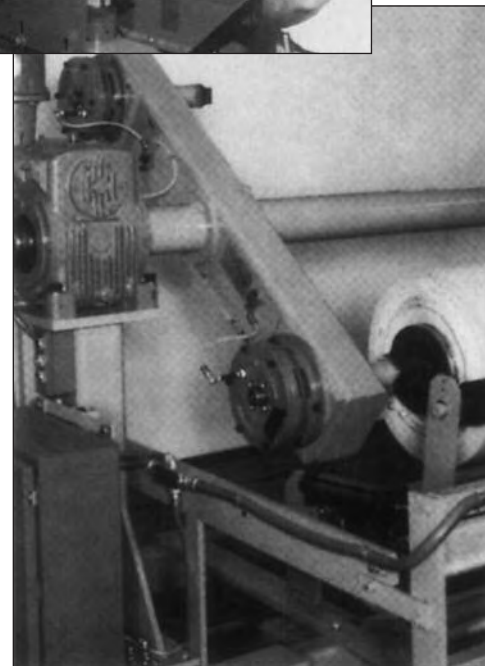

Wichita Low Inertia Brakes increase tension control for paper unwind stands.

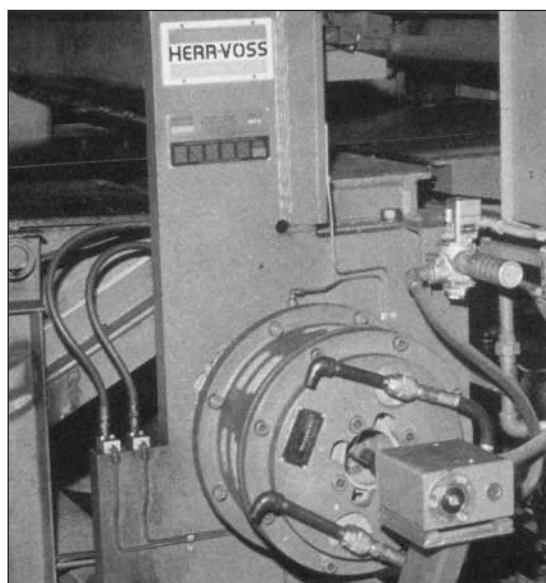

Wichita Spring-Set Air Release Brakes insure accuracy and high performance for a metal shear.





# Air Tube Disc Clutches and Brakes

## Application Factors

Clutch sizes are affected by the following variables:

1. Machines that operate under smooth loads require smaller clutches. These machines are driven by either multi-cylinder high speed engines or electric motors with reduced starting current.
2. Drives that require high starting current motors will require clutches with sufficient torque to prevent excessive slipping while starting.
3. Starting torque may be high, which requires a fast clutch response time to transmit the required torque; or, extended clutch slip time is required to protect the prime mover.
4. Starting torques may be very low compared to the normal torque, which may result in the clutch not being fully pressurized prior to the time of full torque requirement. This will cause the clutch to overheat from slippage. Clutch inflation time in this instance is very important.
5. Clutches on most machines are designed to slip prior to damage from shockloads. As a result, the clutch may require periodic maintenance; therefore, the clutch should be located for easy access in the power train. Clutches should also be located for maximum cooling air. In instances where this is not possible, forced air cooling may be necessary for extended clutch life.
6. Safe clutch operating speeds should be maintained in product design.

Maximum Clutch Contact Velocity	
FPM	Material
6,000 (Recommended)	cast iron
9,000 (upper limit for slip)	ductile iron
12,000	steel

Dynamic balancing recommended when peripheral speeds exceed 3500 FPM. The maximum speeds shown are safe operating speeds based on years of Wichita testing. Please do not exceed these limits.

## Application Guidelines

This chart gives application factors ranging from light duty (the A group) to extra heavy duty (the D group).

After initial usage is determined, see

“Selection Requirements” to complete the selection process. The inflation and exhaust time should also be checked to insure proper response.

Field of Application	Group A	Group B	Group C	Group D
Pumps		Centrifugal compressors	Reciprocating compressors over 2 cylinders, centrifugal fans & blowers	Reciprocating compressors one or two cylinders
Agitators	Liquid	Semi-solid	Solids	
Brick manufacturing			Brick press, extruder, pug mill	
Canning & bottling machine		Bottle-can feeders, filling, mixers		
Engine driven equipment			Crane, hoist, engine	Crowd
Grinding mills			Ball-rod-sag-pebble	Crushers, shakers
Lumber processing		Yarder	Carriages, conveyers	Chipper, logger
Marine		Propulsion clutch CP wheel	Shaft brakes, propulsion reversing type, anchor winch	
Bulk material handling	Conveyors evenly loaded, line shaft evenly loaded	Feeders	Elevators	
Metal production & metalforming		Coilers, slitters, press brake, non-g geared press, geared press	Draw bench, rolling mill, shear, back geared press, deep draw press, transfer press, toggle press	Hammer mill, forming press, forging press, header press, knuckle press
Paper industry dryer sections & calenders Consult factory			Fourdrinier to 500 FPM, paper mill plane & smoothing press	Fourdrinier to 1800 RPM press selections, calenders & dryers
Petroleum production		Drilling & service rig master clutches, compound clutches, rotary, drum		Mud pumps, PTO clutches
Rubber manufacturing	Transfer machines evenly loaded		Banberry mixer, drum mixer, extruder, calender	Centrifuge

# Air Tube Disc Clutches and Brakes

## Low Inertia and Very Low Inertia Clutches and Brakes

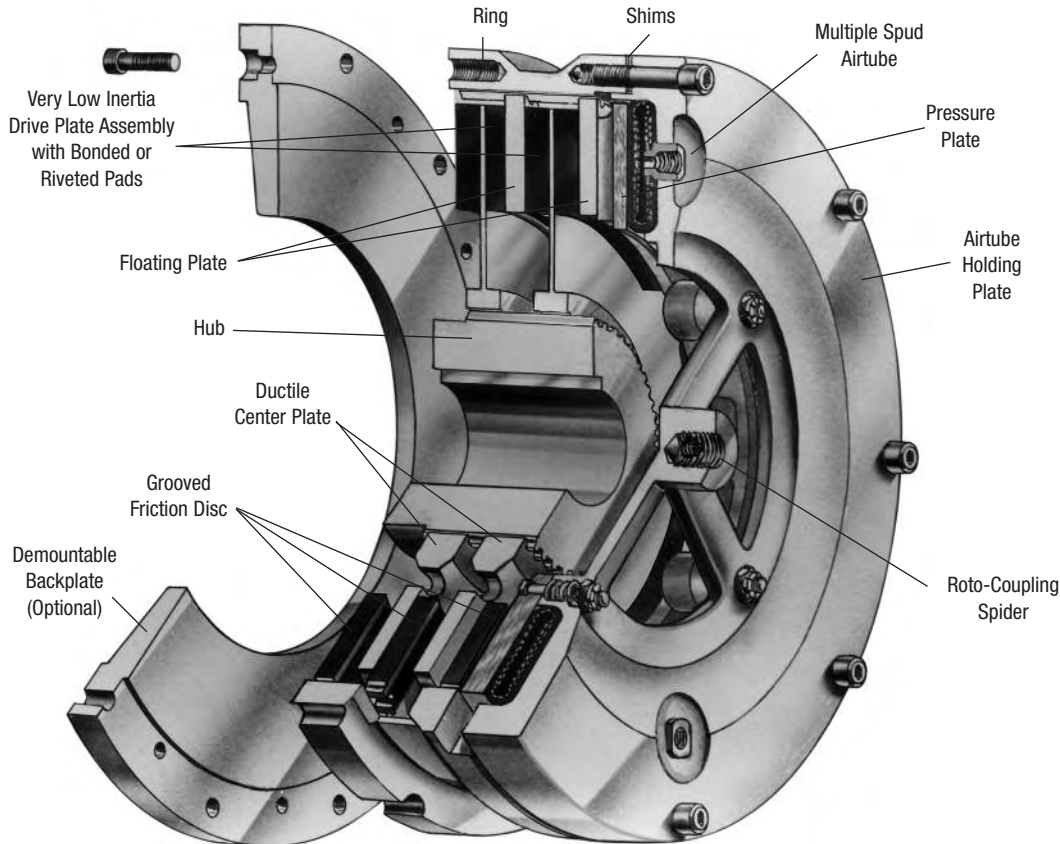

### Operating Features

The Wichita Air-Tube Disc Clutch combines all the best features of the disc type clutch with all the advantages of direct air engagement. The simplest and most trouble-free method of applying air pressure is through direct axial pressure application by compressed air in a special composition full-circle tube.

Wichita Clutches engage smoothly without noise, shock or impact and release completely in a fraction of a second. Extremely fast action is possible because of the small volume of air required.

Clutches may be slipped moderately to control the acceleration rate.

When large inertia loads are powered from electric motors, smooth, controlled slip starts by Wichita Clutches can keep power demands below the allowed maximum.

Heat generated by controlled slipping or high cycle rate operation is dissipated by the centrifugal blower design of these units.

Wichita Low Inertia and Very Low Inertia Clutches and Brakes are designed to be completely free from effects of centrifugal force and self energization.

Torque developed is in direct proportion to air pressure applied.

These clutches and brakes interface well with automated controls through simple air and/or electric circuits.

Water cooled, copper disc clutches are available for use when power transmission needs require excessive or constant slipping which demands higher heat dissipation.

Wichita Clutches operate perfectly when teamed with Wichita Brakes in production situations requiring tension control, cyclic duty, or positioning.

Wichita Brakes have the same outstanding performance characteristics as Wichita Clutches.

# Air Tube Disc Clutches and Brakes

## Low Inertia and Very Low Inertia Clutches and Brakes

### Selection Requirements

The selection of a Low Inertia Brake is based on:

1. Torque required to stop a load.
2. Friction area necessary to absorb rotational energy.
3. Contact velocity of rotating discs.
4. Maximum bore capacity of unit.

### Selection example

To properly select a Low Inertia Brake for a controlled deceleration application, the following information is needed:

Speed . . . . . 750 RPM  
Shaft Dia. . . . . 5 in.  
Inertia to Stop . . . . . 2,473 lb.ft.<sup>2</sup>  
Stop Time . . . . . 5 sec.  
Air Pressure Available . . . . . 80 PSI

### Calculations

$$\begin{aligned} \text{Avg. HP} &= \frac{WR^2 \times (\text{RPM})^2}{3.2 \times 10^6 \times \text{Stop Time}} \\ &= \frac{2,473 \times (750)^2}{3.2 \times 10^6 \times 5 \text{ sec.}} = 87 \text{ HP} \end{aligned}$$

$$\begin{aligned} \text{Swept Friction Area} &= \frac{\text{Avg. HP}}{\text{HP absorption rate for 5 seconds (see page 174)}} \\ &= \frac{87 \text{ HP}}{0.43} = 202 \text{ in.}^2 \end{aligned}$$

$$\begin{aligned} \text{Torque} &= \frac{WR^2 \times \text{RPM}}{25.5 \times \text{Stop Time}} \\ &= \frac{2,473 \times 750}{25.5 \times 5} \\ &= 14,547 \text{ lb.in.} \end{aligned}$$

Using the above calculations, consult the Low Inertia Specifications Chart on pages 26 and 27.

### Summary

As calculated, the torque required to stop the load in 5 seconds is 14,547 lb.in. Wichita Low Inertia Brakes are rated at 100 PSI. This application has only 80 PSI available.

To determine the torque rating of a Low Inertia brake at 80 PSI apply the following formula:

$$\begin{aligned} \text{Application: Torque for a Low Inertia Brake} &= \frac{\text{Torque X Catalog Rated Pressure}}{\text{Available Air Pressure}} \\ &= 14,547 \times \frac{100}{80} = 18,183 \text{ lb.in.} \end{aligned}$$

Consult pages 26 and 36 for clutch and brake specifications. A Low Inertia model 114 Brake produces 27,625 lb.in. torque at 100 PSI. However, the bore capacity is 4.125 inches. This application requires a 5 inch bore. Therefore, a Low Inertia 118 is to be investigated.

Catalog Torque Rating = 64,500 lb.in. @ 100 PSI  
Maximum Bore Capacity = 5.25 in.  
Catalog Swept Friction Area = 264 in.<sup>2</sup>

Calculations show this application needs at least 202 in.<sup>2</sup> to absorb the heat.

All of these ratings are acceptable for the given application data.

Next, check contact velocity of rotating discs.

$$\begin{aligned} &= \frac{\text{Diameter of centerplate X RPM}}{3.82} \\ &= \frac{18" \times 750}{3.82} \\ &= 3,534 \text{ FPM} \end{aligned}$$

Standard material is sufficient up to 6,000 FPM (see page 23). Balancing is recommended above 3,500 FPM.

Therefore, a Low Inertia ATD-118 brake is the optimum choice for this application.

A Spring-Set Air Release Brake is also available (see page 58).

### Note:

This application example is for preliminary sizing only. Contact a Wichita Sales Engineer or the factory for final selection.



# Air Tube Disc Clutches and Brakes

## Low Inertia Clutches Specifications

Model Size ATD-	Assembly Number	Drawing Number	Slip Torque Capacity				Duty Factors HP/100 RPM				Max. Bore Rect. Key	
			lb.in.		Nm		A	B	C	D	in.	(mm)
			80 PSI	100 PSI	5.5 BAR	7 BAR						
LIC 106	6-006-100-211-0	-100-900-9	3,160	3,950	340	435	6.2	4.4	2.2	1.1	2.00	(50)
LIC 206	6-006-200-200-0	-200-900-9	6,320	7,900	680	870	12.5	8.8	4.4	2.2		
LIC 108	6-008-100-103-0	D-1718	5,600	7,000	620	790	11.1	8	4	2		
LIC 208	6-008-200-101-0	-200-900-9	11,200	14,000	1,240	1,580	22.2	16	8	4	2.25	(57)
LIC 308	6-008-300-103-0	D-2843	16,800	21,000	1,865	2,375	33.3	24	12	6		
LIC 111	6-011-100-102-0	-100-900-9	12,720	15,900	1,400	1,785	25	18	9	5		
LIC 211	6-011-200-102-0	-200-900-9	25,440	31,800	2,800	3,570	50	36	18	10	2.50	(64)
LIC 311	6-011-300-100-0	B-322	38,160	47,700	4,235	5,390	75	54	27	15		
LIC 114	6-014-100-102-0	-100-900-9	22,100	27,625	2,435	3,100	44	31	16	8		
LIC 214	6-014-200-104-0	-200-900-9	44,200	55,250	4,870	6,200	88	62	32	16	3.50	(89)
LIC 314	6-014-300-100-0	B-329	66,300	82,875	7,355	9,365	132	93	48	24		
LIC 116	6-016-100-100-0	D-327	30,270	37,838	3,360	4,275	60	46	24	12		
LIC 216	6-016-200-100-0	-200-900-9	60,541	75,676	6,720	8,550	120	92	48	24	4.00	(102)
LIC 316	6-016-300-100-0	D-1205	90,811	113,514	10,080	12,825	180	139	72	36		
LIC 118	6-018-100-100-0	-100-100-0	51,600	64,500	5,705	7,260	102	75	35	21		
LIC 218	6-018-200-100-0	-200-900-9	103,200	129,000	11,410	14,520	204	150	70	42	4.75	(121)
LIC 318	6-018-300-101-0	D-680	154,840	193,550	17,115	21,780	306	225	105	63		
LIC 121	6-021-100-100-0	D-127	69,887	87,359	7,755	9,870	139	107	55	28		
LIC 221	6-021-200-100-0	-200-900-9	139,775	174,719	15,510	19,740	277	213	111	55	6.00	(152)
LIC 321	6-021-300-100-0	D-783	209,662	262,078	23,265	29,610	416	320	166	83		
LIC 124H	6-025-100-100-0	D-347	122,960	153,700	13,575	17,275	243	180	90	40		
LIC 224H	6-025-200-100-0	-200-900-9	245,920	307,400	27,150	34,550	487	360	180	80	6.00	(152)
LIC 324H	6-025-300-201-0	-300-900-9	368,880	461,100	40,725	51,825	729	540	270	120		
LIC 127	6-027-100-100-0	-100-900-9	137,509	171,886	15,260	19,420	273	210	109	55		
LIC 227	6-027-200-100-0	-200-900-9	275,018	343,773	30,520	38,840	546	420	218	109	6.50	(165)
LIC 327	6-027-300-100-0	D-689	412,527	515,659	45,780	58,260	819	630	327	164		
LIC 130H	6-031-100-100-0	B-195	261,600	327,000	29,630	37,710	519	380	190	100		
LIC 230H	6-031-200-349-0	-200-900-9	523,200	654,000	59,260	75,420	1,038	760	380	200	7.25	(184)
LIC 330H	6-031-300-104-0	-300-902-9	784,800	981,000	88,890	113,130	1,557	1,140	570	300		
LIC 136	6-036-100-100-0	-100-900-9	406,400	508,000	44,920	57,175	805	600	295	165		
LIC 236	6-036-200-100-0	D-570	812,800	1,016,000	89,840	114,350	1,610	1,200	590	330	9.00	(229)
LIC 336	6-036-300-100-0	-300-900-9	1,219,200	1,524,000	134,760	171,525	2,415	1,800	885	495		
LIC 142	6-042-100-303-0	-100-900-9	580,800	726,000	69,160	81,660	1,150	850	425	235		
LIC 242	6-042-200-309-0	-200-900-9	1,162,240	1,452,800	128,320	163,320	2,300	1,700	850	470	14.00	(355)
LIC 342	6-042-300-302-0	-300-303-9	1,742,400	2,178,000	192,480	244,980	3,450	2,550	1,275	705		
LIC 148	6-048-100-300-0	-100-901-9	1,122,000	1,402,500	118,800	151,200	2,225	1,600	800	455		
LIC 248	6-048-200-300-0	-200-906-9	2,244,000	2,805,000	237,600	302,400	4,450	3,200	1,600	915	18.00	(455)
LIC 348	6-048-300-110-0	-300-900-9	3,366,000	4,207,500	356,400	453,600	6,675	4,800	2,400	1,365		
LIC 260	6-060-200-302-0	-200-907-9	4,760,000	5,950,000	473,000	602,000	9,440	5,950	3,470	1,940		
LIC 360	6-060-300-201-0	-300-901-9	7,140,000	8,925,000	709,000	902,300	14,160	8,925	5,205	2,910	19.00	(480)
LIC 460	6-060-400-300-0	E-236	14,280,000	17,850,000	946,000	1,204,000	18,880	11,900	6,940	3,880		

Maximum Air Pressure is 130 PSI / 9 BAR.

# Air Tube Disc Clutches and Brakes

## Low Inertia Clutches Specifications

Model Size ATD-	Recom- mended Clearance in.	Balance Speed RPM	Airtube Type		Swept Area in. <sup>2</sup>	Airtube Volume in. <sup>3</sup> /(cm <sup>3</sup> )		Total Clutch				Hub & Center Plate			
			Reg- Speed RPM	High Speed RPM*		New	Worn	Wt.		WR <sup>2</sup> / J=mr <sup>2</sup>		Wt.		WR <sup>2</sup> / J=mr <sup>2</sup>	
								lb.	(kg)	lb.ft. <sup>2</sup>	(kgm <sup>2</sup> )	lb.	(kg)	lb.ft. <sup>2</sup>	(kgm <sup>2</sup> )
LIC 106	1/16-3/32				39	1.8	11.9	27.5	(12)	2.5	(0.105)	6.40	(2.9)	0.24	(0.010)
LIC 206	3/32-5/32	2,225	1,800	2,600*	78	(30)	(195)	40.5	(18)	3.3	(0.139)	12.17	(5.5)	0.46	(0.019)
LIC 108	1/16-1/8				56			62	(28)	7.5	(0.315)	11	(5.0)	0.54	(0.023)
LIC 208	3/32-5/32	1,675	1,750	3,000*	112	3.4	18.3	70	(32)	8.5	(0.357)	19	(8.6)	1.00	(0.042)
LIC 308	1/8-3/16				168	(56)	(300)	92	(42)	99	(4.174)	28	(12.7)	2.00	(0.084)
LIC 111	1/16-1/8				114			133	(60)	27	(1.14)	23	(10.4)	2.30	(0.097)
LIC 211	3/32-5/32	1,200	1,400	2,800*	228	5.5	30.5	170	(77)	34	(1.43)	45	(20.4)	4.50	(0.190)
LIC 311	1/8-3/16				342	(90)	(500)	208	(94)	52	(2.19)	121	(54.9)	7.00	(0.295)
LIC 114	1/16-1/8				158			184	(83)	56	(2.36)	46	(20.9)	5.7	(0.240)
LIC 214	3/32-5/32	950	1,200	2,200*	316	7.6	42.7	233	(106)	70	(2.95)	77	(34.9)	11.0	(0.464)
LIC 314	1/8-3/16				474	(125)	(700)	292	(132)	80	(3.37)	121	(54.9)	16.7	(0.704)
LIC 116	1/16-1/8				228			257	(117)	103	(4.34)	59	(26.8)	10.2	(0.430)
LIC 216	3/32-5/32	835	1,200	2,000*	455	9.8	56.1	326	(148)	125	(5.27)	106	(48.1)	19.6	(0.826)
LIC 316	1/8-3/16				683	(161)	(919)	358	(162)	125	(5.27)	151	(68.5)	29.6	(1.248)
LIC 118	1/16-1/8				264			311	(141)	158	(6.66)	73	(33.1)	15.0	(0.632)
LIC 218	3/32-5/32	750	1,000	2,000*	528	15.3	85.4	377	(171)	183	(7.72)	120	(54.4)	28.8	(1.214)
LIC 318	1/8-3/16				792	(251)	(1,400)	472	(214)	219	(9.23)	180	(81.6)	43.2	(1.821)
LIC 121	3/32-5/32				362			467	(212)	303	(12.77)	116	(52.6)	32	(1.35)
LIC 221	1/8-3/16	650	900	1,650*	724	18.3	97.6	582	(264)	356	(15.01)	198	(89.8)	61	(2.57)
LIC 321	5/32-7/32				1,086	(300)	(1,599)	730	(331)	450	(18.97)	272	(123.4)	92	(3.88)
LIC 124H	3/32-5/32				574			637	(289)	468	(19.73)	132	(60.0)	56	(2.4)
LIC 224H	1/8-3/16	550	700	1,400*	1,148	29.9	159	830	(376)	618	(26.05)	260	(117.9)	109	(4.6)
LIC 324H	5/32-7/32				1,722	(490)	(2,606)	1,025	(465)	735	(31.00)	379	(172.0)	160	(6.8)
LIC 127	3/32-5/32				730			770	(349)	706	(29.8)	187	(84.8)	98	(4.1)
LIC 227	1/8-3/16	500	700	1,400*	1,460	29.9	159	950	(431)	862	(36.3)	322	(146.1)	193	(8.1)
LIC 327	5/32-7/32				2,190	(490)	(2,606)	1,112	(504)	969	(40.9)	555	(251.7)	285	(12.0)
LIC 130H	3/32-5/32				827			1,035	(469)	1,170	(49.3)	298	(135.2)	189	(8.0)
LIC 230H	1/8-3/16	450	600	1,100*	1,654	58.6	311	1,411	(640)	1,552	(65.4)	546	(247.7)	370	(15.6)
LIC 330H	5/32-7/32				2,481	(960)	(5,096)	1,751	(794)	1,788	(75.4)	810	(367.4)	477	(20.1)
LIC 136	3/32-5/32				1,150			1,455	(660)	2,368	(99.8)	461	(209.1)	372	(15.7)
LIC 236	1/8-3/16	375	600	900*	2,300	110	415	1,992	(904)	3,247	(136.9)	708	(321.1)	725	(30.6)
LIC 336	5/32-7/32				3,450	(1,803)	(6,801)	2,610	(1,184)	4,057	(171.0)	1,134	(514.4)	1,091	(46.0)
LIC 142	5/32-7/32				1,400			1,967	(892)	4,721	(199)	680	(308)	705	(30)
LIC 242	3/16-1/4	325	500	800*	2,800	128	488	2,732	(1,239)	5,750	(242)	1,197	(543)	1,385	(58)
LIC 342	7/32-9/32				4,200	(2,098)	(7,997)	3,704	(1,680)	9,191	(387)	1,324	(601)	1,809	(76)
LIC 148	1/8-1/4				2,010			3,158	(1,432)	9,325	(393)	1,101	(499)	1,785	(75)
LIC 248	5/32-7/32	275	400	700*	4,020	217	824	4,700	(2,132)	13,775	(581)	1,942	(881)	3,335	(141)
LIC 348	3/16-5/16				6,030	(3,550)	(13,500)	6,540	(2,966)	18,000	(759)	2,950	(1,338)	4,925	(208)
LIC 260	3/16-5/16				7,230			9,453	(4,288)	48,733	(2,055)	2,567	(1,164)	7,077	(298)
LIC 360	1/4-3/8	225	320	550*	10,845	513	1,788	11,643	(5,281)	57,286	(2,415)	3,870	(1,755)	10,615	(448)
LIC 460	5/16-7/16				14,460	(8,407)	(29,300)	14,500	(6,577)	68,980	(2,908)	5,700	(2,585)	15,070	(635)

\* Consult Factory for Special Assembly Number.

# Air Tube Disc Clutches and Brakes

## Air System Data

### PSI pressure

#### Inflation

Clutch air pressure during inflation can be closely estimated by the following:

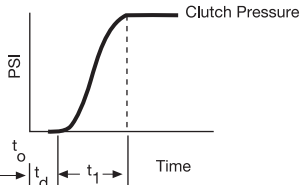

$$t_1 = \left(\frac{3}{K}\right)^{\frac{1}{U}} \text{ sec.} = \text{Time to 95\% Full Inflation}$$

$$\text{Clutch pressure} = P_1 \left(1 - \frac{1}{e^{Kt^U}}\right) \text{ PSI (inflation)}$$

This equation is accurate from 5% up to 95%  $P_1$ .

$P_1$  = Line pressure to clutch PSI

K and U = coefficients for specific clutch and air pressure from Specification Table

e = Napierian base log

$t_o$  = Time at initiation of signal for inflation sec.

$t_d$  = Time delay of air system – sec.

#### Exhaust

Clutch air pressure during exhaust can be closely estimated by the following:

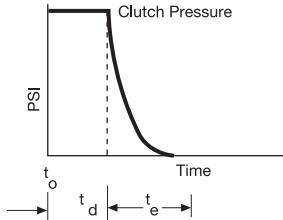

$$\text{Clutch pressure} = (P_1) (R) (E-t)^V \text{ PSI (exhaust)}$$

R, E and V = coefficients for specific clutch and air pressure from Specification Table

$t_e$  = Time to exhaust = E from Specification Table

t = Time variable – seconds. In the exhaust equation “t” cannot exceed the value of “E” sec.

#### Overlap

A typical clutch-brake torque curve for a single backshaft press (cyclic application) would appear as shown below.

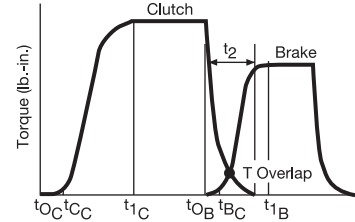

#### Time (sec.)

$t_{oC}$  = time at which disengaged clutch receives signal

$t_{cC}$  = time of clutch engagement

$t_{1C}$  = time of clutch full inflation

$t_{oB}$  = time at which disengaged brake receives signal

$t_{cB}$  = time of brake engagement

$t_{1B}$  = time of brake full exhaust

$t_2$  = overlap time at which clutch and brake are both engaged

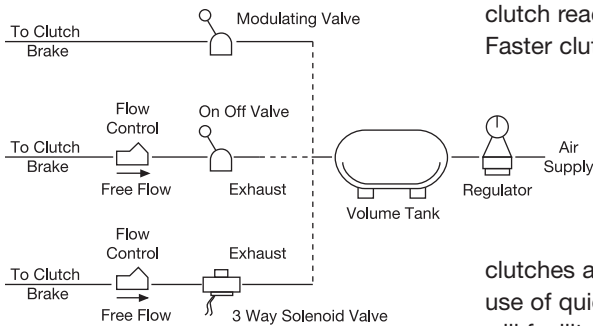

Shown are some of the air systems used on Wichita clutches. These systems are acceptable for remote operation where clutch reaction time is not important.

Faster clutch reaction time is accomplished as indicated in the diagram by locating the flow control valve, if required, and the solenoid valve as close as possible to the roto-coupling. Where

clutches are located on long shafts, the use of quick release valves on the clutch will facilitate faster clutch response.

clutches are located on long shafts, the use of quick release valves on the clutch will facilitate faster clutch response.

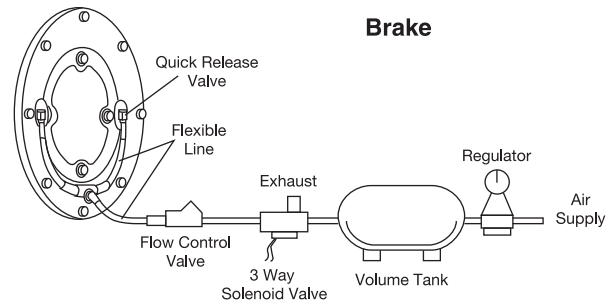
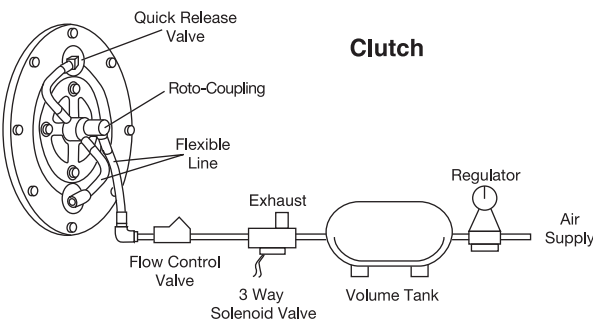

# Air Tube Disc Clutches and Brakes

## Low Inertia and Very Low Inertia Clutches and Brakes

### Inflation Coefficients

Model Size ATD-	Inflation Coefficients Operating Air Pressure					
	50 PSI		75 PSI		100 PSI	
	K	U	K	U	K	U
108	15,800	2.2	7,100	2	265	1.2
208	15,800	2.2	7,100	2	265	1.2
111	890	1.7	880	1.6	5,100	2.2
211	890	1.7	880	1.6	5,100	2.2
114	980	2.3	980	2.3	980	2.3
214	980	2.3	980	2.3	980	2.3
118	9,600	3.1	1,560	2.4	9,600	3.1
218	9,600	3.1	1,560	2.4	9,600	3.1
124H	145	1.8	90	1.6	87	1.6
224H	145	1.8	90	1.6	87	1.6
130H	185	2	150	2	93	1.8
230H	185	2	150	2	93	1.8
136	170	2	250	2.2	160	2
236	170	2	250	2.2	160	2
142	115	2	125	2	111	2
242	115	2	125	2	111	2
148	25	1.6	22	1.6	26	1.8
248	25	1.6	22	1.6	26	1.8
260	28	1.8	22	1.8	20	1.8
360	28	1.8	22	1.8	20	1.8

### Exhaust Coefficients

Model Size ATD-	Exhaust Coefficients Operating Air Pressure								
	50 PSI			75 PSI			100 PSI		
	R	E	V	R	E	V	R	E	V
108	60	.016	1.0	525	.02	1.6	240	.02	1.4
208	60	.016	1.0	525	.02	1.6	240	.02	1.4
111	1,000	.032	2	8,200	.04	2.8	4,930	.048	2.8
211	1,000	.032	2	8,200	.04	2.8	4,930	.048	2.8
114	720	.072	2.5	800	.069	2.5	1,840	.082	3
214	720	.072	2.5	800	.069	2.5	1,840	.082	3
118	44	.068	1.4	40	.072	1.4	34	.08	1.4
218	44	.068	1.4	40	.072	1.4	34	.08	1.4
124H	360	.096	2.5	240	.112	2.5	270	.136	2.8
224H	360	.096	2.5	240	.112	2.5	270	.136	2.8
130H	120	.104	2.1	140	.128	2.4	146	.158	2.7
230H	120	.104	2.1	140	.128	2.4	146	.158	2.7
136	124	.112	2.2	92	.128	2.2	76	.152	2.3
236	124	.112	2.2	92	.128	2.2	76	.152	2.3
142	132	.12	2.3	89	.144	2.3	61	.168	2.3
242	132	.12	2.3	89	.144	2.3	61	.168	2.3
148	20	.224	2	20	.256	2.2	19	.308	2.5
248	20	.224	2	20	.256	2.2	19	.308	2.5
260	24	.264	2.4	10	.367	2.3	9.9	.352	2.2
360	24	.264	2.4	10	.367	2.3	9.9	.352	2.2

# Air Tube Disc Clutches and Brakes

## Low Inertia Clutches

Sizes 8-36

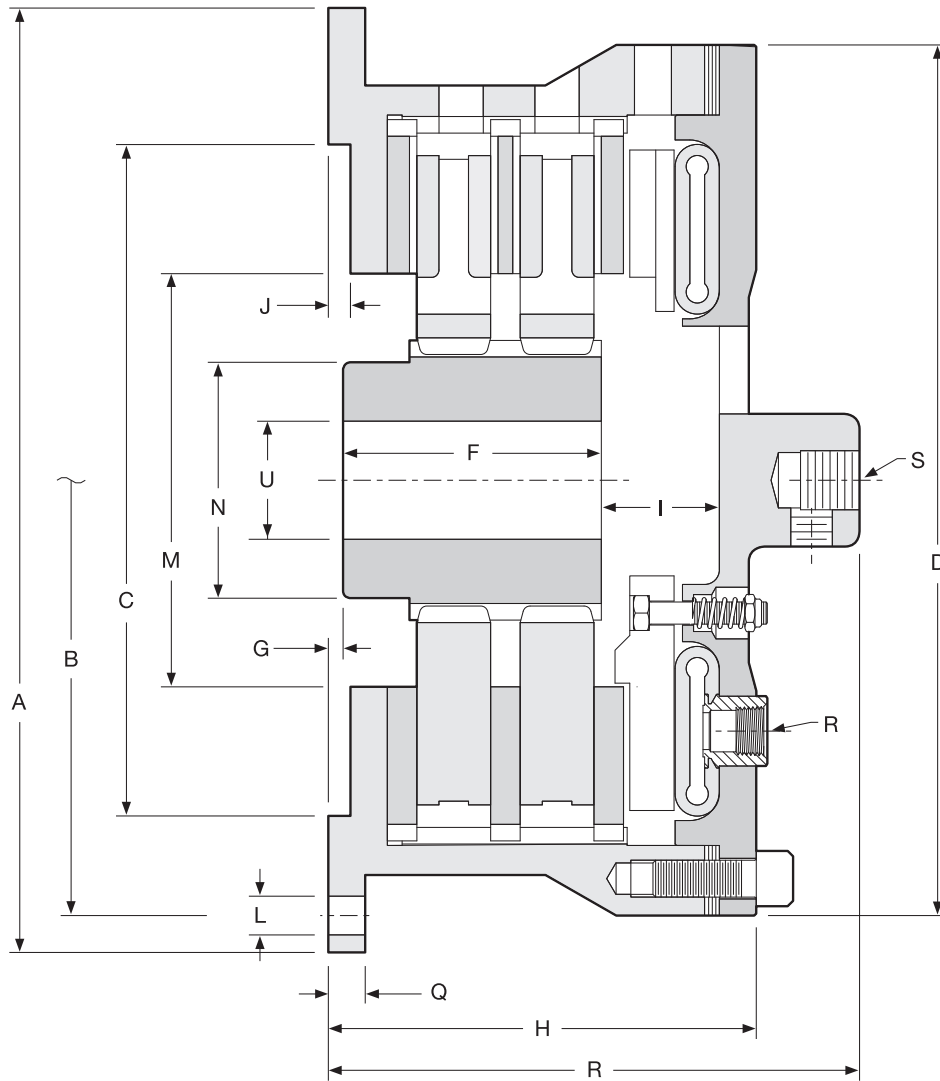



# Air Tube Disc Clutches and Brakes

## Low Inertia Clutches

### Sizes 8-36

#### Dimensions: inches (mm)

Model Size ATD-	A	B Hole Circle	C Pilot	D	E	F	G	H
LIC 108	12.13	11.125	8.375 / 8.378	11.13	6.31 (160.3)	2.00 (50.8)	.25 (6.4)	4.56 (115.8)
LIC 208	(308.1)	(282.58)	(212.73 / 212.80)	(282.7)	7.69 (195.3)	3.25 (82.6)	.31 (7.9)	5.94 (150.9)
LIC 111	16.00	14.750	11.375 / 11.378	14.75	7.25 (184.2)	2.75 (69.9)	.13 (3.3)	5.50 (139.7)
LIC 211	(406.4)	(374.65)	(288.93 / 289.00)	(374.7)	9.00 (228.6)	4.38 (111.3)	.25 (6.4)	7.25 (184.2)
LIC 114	18.75	17.500	14.375 / 14.378	17.50	7.56 (192.0)	3.75 (95.3)	.13 (3.3)	6.06 (153.9)
LIC 214	(476.3)	(444.50)	(365.13 / 365.20)	(444.5)	9.38 (238.3)	4.50 (114.3)	.38 (9.7)	7.88 (200.2)
LIC 116					7.81 (198.4)	4.00 (101.6)		6.31 (160.3)
LIC 216	21.25	20.000	16.250 / 16.253	20.00	9.75 (247.7)	4.75 (120.7)	.38 (9.7)	8.25 (209.6)
LIC 316	(539.8)	(508.00)	(412.75 / 412.83)	(508.0)	11.69 (296.9)	6.63 (168.4)		10.19 (258.8)
LIC 118					8.19 (208.0)	4.00 (101.6)		6.69 (169.9)
LIC 218	23.25	22.000	18.250 / 18.253	22.00	10.13 (257.3)	4.75 (120.7)	.44 (11.2)	8.63 (219.2)
LIC 318	(590.6)	(558.80)	(463.55 / 463.63)	(558.8)	12.13 (308.1)	6.50 (165.1)		10.63 (270.0)
LIC 121					8.88 (225.6)	4.00 (101.6)	.75 (19.1)	7.38 (187.5)
LIC 221	27.00	25.500	21.375 / 21.378	24.88	10.94 (277.9)	5.13 (130.3)	.63 (16.0)	9.44 (239.8)
LIC 321	(685.8)	(647.70)	(542.93 / 543.00)	(632.0)	13.25 (336.6)	7.13 (181.1)	.75 (19.1)	11.75 (298.5)
LIC 124H					9.13 (231.9)	4.00 (101.6)	.69 (17.5)	7.63 (193.8)
LIC 224H	30.00	28.750	24.375 / 24.378	29.00	11.38 (289.1)	5.13 (130.3)	.75 (19.1)	9.88 (251.0)
LIC 324H	(762)	(730.25)	(619.13 / 619.20)	(736.6)	13.75 (349.3)	7.50 (190.5)	.75 (19.1)	12.25 (311.2)
LIC 127					9.38 (238.3)	4.50 (114.3)	.75 (19.1)	7.88 (200.2)
LIC 227	32.75	31.500	27.375 / 27.378	31.00	11.88 (301.8)	6.88 (174.8)		10.38 (263.7)
LIC 327	(831.9)	(800.10)	(695.33 / 695.40)	(787.4)	—	—	—	—
LIC 130H					12.5	5.00 (127.0)	.63 (16.0)	8.25 (209.6)
LIC 230H	37.00	35.500	30.375 / 30.3783	34.75	15.94	7.13 (181.1)	1.88 (47.8)	11.69 (296.9)
LIC 330H	(939.8)	(901.70)	(771.53 / 771.60)	(882.7)	—	—	—	—
LIC 136					12.94 (328.7)	5.63 (143.0)		9.44 (239.8)
LIC 236	43.50	42.000	36.375 / 36.378	41.00	16.63 (422.4)	9.00 (228.6)	.63 (16.0)	12.75 (323.9)
LIC 336	(1,104.9)	(1,066.80)	(923.93 / 924.00)	(1,041.4)	19.88 (505.0)	12.38 (314.5)		16.38 (416.1)

#### Dimensions: inches (mm)

Model Size ATD-	I	J	L		M	N	Q	R		S	U	
			No. -	Size				No. -	Size		Min.	Max.
LIC 108	1.78 (45.2)	.25			5.38	3.50	.50			1" -14NF	1.00	2.00
LIC 208	1.88 (47.8)	(6.4)	6 -	17/32 (13.5)	(136.7)	(88.9)	(12.7)	2 -	1/2 NPT	1" -14NF	(25)	(50.8)
LIC 111		.38	6 -	11/16 (17.5)	7.00	4.00	.63	2 -	1/2 NPT	1" -14NF	1.00	2.50
LIC 211	2.00 (50.8)	(9.7)	6 -	21/32 (16.7)	(177.8)	(101.6)	(16.0)	2 -	1/2 NPT	1" -14NF	(25)	(63.5)
LIC 114	1.44 (36.6)	.38	8 -	21/32 (16.7)	9.44	5.50	.63	2 -	1/2 NPT	1" -14NF	1.38	3.50
LIC 214	2.13 (54.1)	(9.7)	8 -	21/32 (16.7)	(239.8)	(139.7)	(16.0)	2 -	1/2 NPT	1" -14NF	(35.1)	(88.9)
LIC 116	1.13 (28.7)											
LIC 216	2.31 (58.7)	.38	12 -	21/32 (16.7)	10.50	6.00	.63	2 -	1/2 NPT	1" -14NF	1.38	4.00
LIC 316	2.31 (58.7)	(9.7)	12 -	21/32 (16.7)	(266.7)	(152.4)	(16.0)	2 -	1/2 NPT	1" -14NF	(35.1)	(101.6)
LIC 118	1.25 (31.8)											
LIC 218	2.50 (63.5)	.38	12 -	21/32 (16.7)	12.50	7.00	.63	3 -	1/2 NPT	1" -14NF	2.00	4.75
LIC 318	2.75 (69.9)	(9.7)	12 -	21/32 (16.7)	(317.5)	(177.8)	(16.0)	3 -	1/2 NPT	1" -14NF	(50.8)	(120.7)
LIC 121	1.63 (41.4)											
LIC 221	2.68 (68.1)	.31	12 -	21/32 (16.7)	14.50	9.00	.75	3 -	1/2 NPT	1" -14NF	2.00	6.00
LIC 321	2.75 (69.9)	(7.9)	12 -	21/32 (16.7)	(368.3)	(228.6)	(19.1)	3 -	1/2 NPT	1" -14NF	(50.8)	(152.4)
LIC 124H	1.75 (44.5)											
LIC 224H	2.94 (74.7)	.25	12 -	21/32 (16.7)	14.50	9.00	.75	3 -	1/2 NPT	1" -14NF	2.00	6.00
LIC 324H	2.88 (73.2)	(6.4)	12 -	21/32 (16.7)	(368.3)	(228.6)	(19.1)	3 -	1/2 NPT	1" -14NF	(50.8)	(152.4)
LIC 127	1.38 (35.1)	.25										
LIC 227	1.50 (38.1)	(6.4)	16 -	21/32 (16.7)	16.25	9.00	.75	3 -	1/2 NPT	1" -14NF	2.50	6.50
LIC 327	—	—	16 -	21/32 (16.7)	(412.8)	(228.6)	(19.1)	3 -	1/2 NPT	1" -14NF	(63.5)	(165.1)
LIC 130H	1.81 (46.0)											
LIC 230H	1.88 (47.8)	.25	18 -	25/32 (19.8)	19.25	10.00	.75	4 -	1/2 NPT	1" NPT	2.50	7.25
LIC 330H	—	(6.4)	18 -	25/32 (19.8)	(489)	(254)	(19.1)	4 -	1/2 NPT	1" NPT	(63.5)	(184.2)
LIC 136	1.38 (35.1)											
LIC 236	1.63 (41.4)	.25	18 -	25/32 (19.8)	23.63	12.00	.88	4 -	1/2 NPT	1" NPT	6.00	9.00
LIC 336	1.75 (44.5)	(6.4)	18 -	25/32 (19.8)	(600.2)	(304.8)	(22.4)	4 -	1/2 NPT	1" NPT	(152.4)	(228.6)

Note: For mounting, use socket head capscrews conforming to the ASTM-574-97a. (Consult factory for drawing before final layout.)

# Air Tube Disc Clutches and Brakes

## Low Inertia Clutches

Sizes 6, 42-60

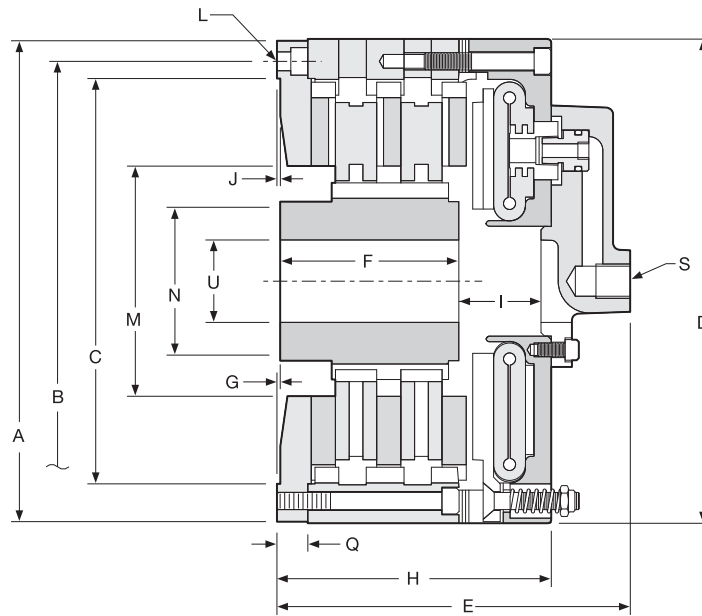

Size 6

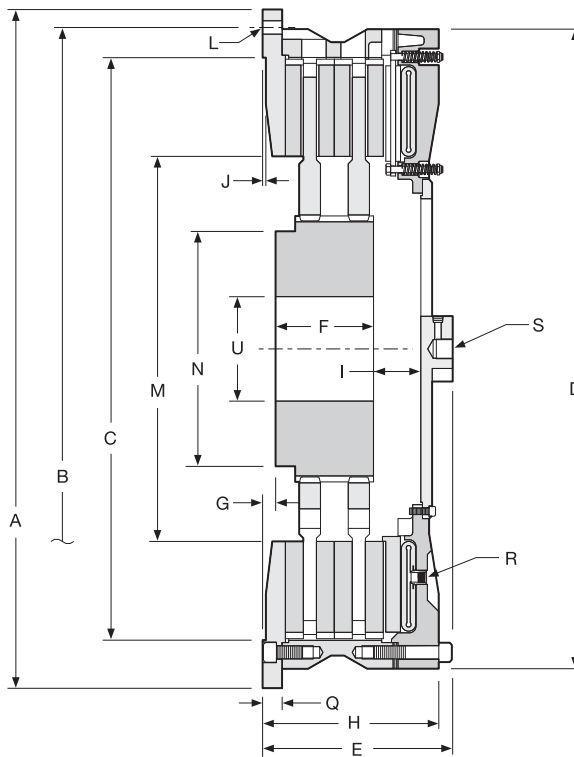

Size 42-60

# Air Tube Disc Clutches and Brakes

## Low Inertia Clutches

Sizes 6, 42-60

### Dimensions: inches (mm)

Model Size ATD-	A	B Hole Circle	C Pilot	D	E	F	G	H
LIC 106	8.75	8.000	7.377 / 7.379	8.81	5.19 (131.8)	2.00 (50.8)	0.00 (0.0)	3.75 (95.3)
LIC 206	(222.3)	(203.20)	(187.38 / 187.43)	(223.8)	6.43 (163.3)	3.25 (82.6)	0.06 (1.5)	5.00 (127.0)
LIC 142	52.00	49.250	44.625 / 44.628	49.00	10.81 (274.6)	5.63 (143.0)	1.00 (25.40)	9.75 (247.7)
LIC 242	(1,320.8)	(1,250.95)	(1,133.48 / 1,133.55)	(1,244.6)	14.56 (369.8)	7.50 (190.5)		13.5 (342.9)
LIC 148	61.00	58.000	52.000 / 52.005	56.75	14.69 (373.1)	6.00 (152.4)	0.00 (0.0)	10.69 (271.5)
LIC 248	(1,549.4)	(1,473.20)	(1,320.80 / 1,320.93)	(1,441.5)	19.07 (484.4)	8.75 (222.3)	1.00 (25.4)	15.07 (382.8)
LIC 260 <sup>1</sup>					20.30 (515.6)	9.38 (238.3)	0.25 (6.4)	17.99 (456.9)
LIC 360 <sup>1</sup>	70.50	66.500	62.750 / 62.760	70.50	22.00 (558.8)	12.25 (311.2)	0.00 (0.0)	19.63 (498.6)
LIC 460 <sup>1</sup>	(1,790.7)	(1,689.10)	(1,593.85 / 1,594.10)	(1,790.7)	28.25 (717.6)	18.63 (473.2)	0.25 (6.4)	27.13 (689.1)

### Dimensions: inches (mm)

Model Size ATD-	I	J	L		M	N	Q	R		S	U	
			No.-	Size				No. -	Size		Min.	Max.
LIC 106	1.56 (39.6)	0.06	4 -	0.34 (8.6)	4.19	2.69	0.56	—	5/8"-11NF	0.60	2.00	
LIC 206	1.50 (38.1)	(1.5)			(106.4)	(68.3)	(14.2)			(15.2)	(50.8)	
LIC 142	1.75 (44.5)	0.25	24 -	1.06 (26.9)	29.50	18.00	1.50	4 - 1/2 NPT	1.5"-12NF	8.00	14.00	
LIC 242	3.63 (92.2)	(6.4)			(749.3)	(457.2)	(38.1)			(203.2)	(355.6)	
LIC 148	3.69 (93.7)	0.25	24 -	1.06 (26.9)	32.00	25.75	1.50	4 - 1/2 NPT	1" NPT	10.00	18.00	
LIC 248	4.32 (109.7)	(6.4)			(812.8)	(654.1)	(38.1)			(254.0)	(457.2)	
LIC 260 <sup>1</sup>	6.17 (156.7)											
LIC 360 <sup>1</sup>	5.19 (131.8)	0.25	24 -	4.5"NC	36.00	27.00	—	6 - 1/2 NPT	2"-12NF	11.00	19.00	
LIC 460 <sup>1</sup>	6.38 (162.1)	(6.4)			(914.4)	(685.8)				(279.4)	(482.6)	

<sup>1</sup>Less backplate.

**NOTE:** For mounting, use socket head capscrews conforming to the ASTM-574-97a.  
(Consult factory for drawing before final layout.)

# Air Tube Disc Clutches and Brakes

## Low Inertia Clutch Air Hose Kits

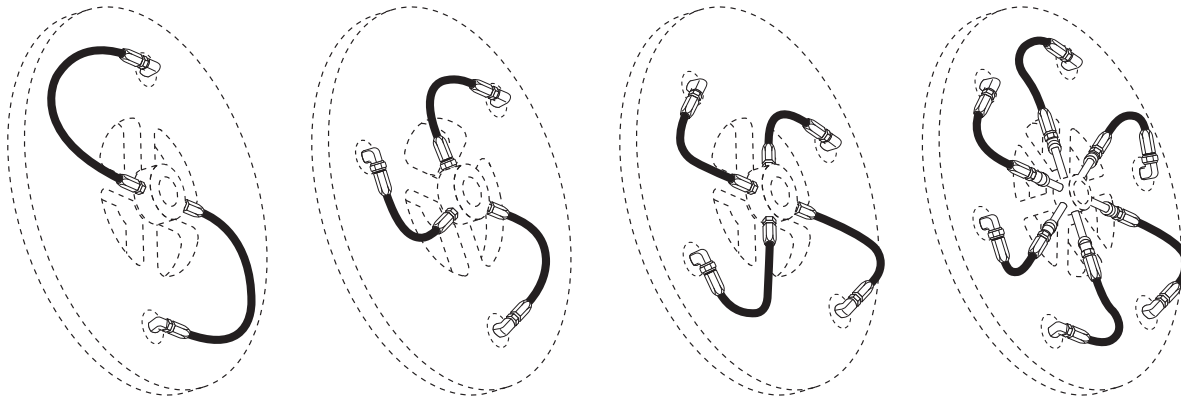

Size	Part Number	Size	Part Number	Size	Part Number	Size	Part Number
8"	8-908-812-200-5 8-908-821-201-5 QRV	18"	8-918-812-301-5 8-918-821-300-5 QRV	30"	8-930-812-400-5 8-930-821-400-5 QRV	60"	8-960-800-500-7 QRV
11"	8-911-812-201-5 8-911-821-201-5 QRV	24"H	8-924-812-300-5 8-924-821-301-5 QRV	36"	8-936-821-400-5 QRV		
14"	8-914-812-200-5 8-914-821-200-5 QRV			42"	8-942-821-400-5 QRV		
				48"	8-948-821-400-5 QRV		

Air hose kits contain all necessary parts (fittings, hoses and extensions) to completely plumb the clutch air system.

Optional Quick Release Valves can replace elbows on most units (see page 35).

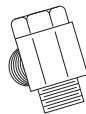

Roto-couplings (see page 35).



# Air Tube Disc Clutches and Brakes

## Quick Release Valve

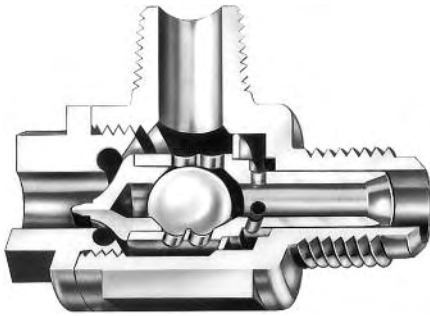

8-263-610-011-1 7/8" – 14 Thread  
 8-263-610-021-1 1/2" NPT  
 4-263-605-002-0 Optional Muffler

The Wichita Springless Quick Release Valve discharges twice as fast as any other valve tested in our laboratory and is four to five times faster than some common makes of valves.

This valve will close and seal with less than 20 lbs. pressure. Most others require 25 to 30 lbs. to definitely seal. In actual tests, the Wichita Valve made many hundreds of thousands of engagements and disengagements before the slightest leak occurred, or any parts needed replacement. Other valves which were tested required major replacement in fewer than 20,000 cycles.

## Quality Material

Body and Cap: High strength aluminum alloy  
 Stem: Molded nylon  
 Check Valve: Nylon ball  
 "O" Ring: Neoprene

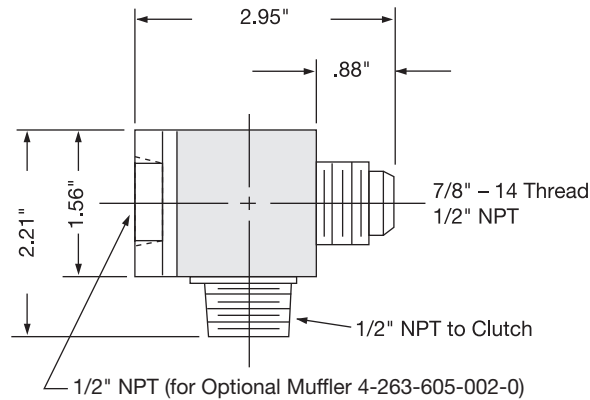

Standard thread arrangement of 1/2" size. 1/2" pipe thread on the tube connection and choice of 1/2" pipe thread, or standard 7/8-14NF thread for flared fitting thread on inlet connection. (Fits standard No. 10 high-pressure hose fitting.)

## Roto-couplings

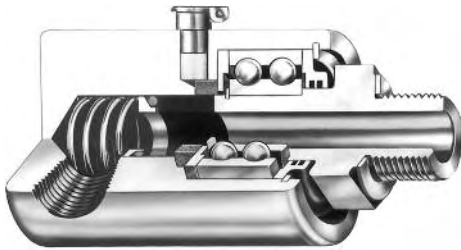

The Wichita Roto-coupling is a device to connect, or couple, a non-rotating air, gas, or fluid line to a rotating shaft.

- Long life, no maintenance.
- Felt seal eliminates bearing contamination.
- Fast, easy installation.

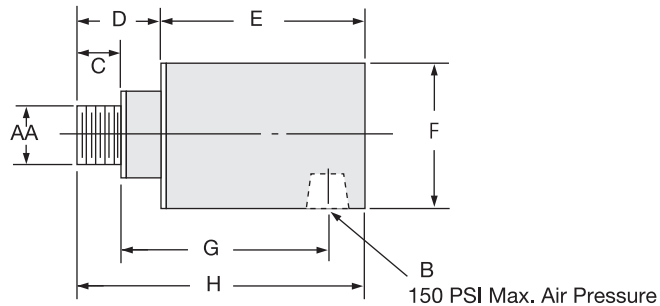

## Dimensions: inches

Wichita Part No.	AA	B	C	D	E	F	G	H	Max. RPM
8-240-701-003-1	5/8-18NF	1/4" NPT	.40	1.046	2.250	1.500	2.13	3.297	3500
8-240-705-001-1	1"-14 NF	1/2" NPT	.75	1.250	3.188	2.500	3.00	4.438	3500
8-240-708-001-1	1"-14 NF	3/4" NPT	.75	1.313	4.688	2.875	3.69	5.440	3500
8-240-710-002-1	1-1/2"-12 NF	1" NPT	1.13	1.937	4.875	3.250	3.44	6.812	2500
8-240-712-001-1	2"-12 NF	1-1/2" NPT	1.13	2.813	5.250	4.250	5.38	8.062	2500
8-240-714-001-3	2" NPT	2" NPT	1.50	3.000	7.062	4.625	7.00	10.062	1000
8-240-716-000-3	2-1/2" NPT	2-1/2" NPT	1.88	3.250	9.375	7.000	7.75	12.625	750



# Air Tube Disc Clutches and Brakes

## Low Inertia Brakes Specifications

Model Size ATD-	Assembly Number	Drawing Number	Slip Torque Capacity				Duty Factors HP/100 RPM				Max. Bore Rect. Key	
			lb.in.		Nm		A	B	C	D	in.	(mm)
			80 PSI	100 PSI	5.5 BAR	7 BAR						
LIB 104	7-004-100-803-0	-100-901-9	800	1,000	90	113	1.6	1.2	0.6	0.3	1.00	(25)
LIB 204	7-004-200-801-0	B-518	1,600	2,000	90	225	3.2	2.4	1.2	0.6		
LIB 106	7-006-100-203-0	-100-901-9	3,160	3,950	340	435	6.2	4.4	2.2	1.1	2.00	(50)
LIB 206	7-006-200-200-0	D-465	6,320	7,900	680	870	12.5	8.8	4.4	2.2		
LIB 108	7-008-100-108-0	-100-900-9	5,600	7,000	620	790	11.1	8	4	2		
LIB 208	7-008-200-105-0	-200-900-9	11,200	14,000	1,240	1,580	22.2	16	8	4	2.25	(57)
LIB 308	7-008-300-100-0	D-164	16,800	21,000	1,865	2,375	33.3	24	12	6		
LIB 111	7-011-100-107-0	B-105	12,720	15,900	1,400	1,785	25	18	9	5		
LIB 211	7-011-200-102-0	-200-902-9	25,440	31,800	2,800	3,570	50	36	18	10	2.50	(64)
LIB 311	7-011-300-100-0	B-408	38,160	47,700	4,235	5,390	75	54	27	15		
LIB 114	7-014-100-102-0	-100-900-9	22,100	27,625	2,435	3,100	44	31	16	8		
LIB 214	7-014-200-101-0	-200-902-9	44,200	55,250	4,870	6,200	88	62	32	16	3.50	(89)
LIB 314	7-014-300-102-0	B-288	66,300	82,875	7,355	9,365	132	93	48	24		
LIB 116	7-016-100-100-0	D-461	30,270	37,838	3,360	4,275	60	46	24	12		
LIB 216	7-016-200-100-0	-200-904-9	60,541	75,676	6,720	8,550	120	92	48	24	4.00	(102)
LIB 316	7-016-300-100-0	-300-900-9	90,811	113,514	10,080	12,825	180	139	72	36		
LIB 118	7-018-100-100-0	-100-901-9	51,600	64,500	5,705	7,260	102	75	35	21		
LIB 218	7-018-200-100-0	-200-900-9	103,200	129,000	11,410	14,520	204	150	70	42	4.75	(121)
LIB 318	7-018-300-103-0	D-1218	154,840	193,550	17,115	21,780	306	225	105	63		
LIB 121	7-021-100-100-0	D-373	69,887	87,359	7,755	9,870	139	107	55	28		
LIB 221	7-021-200-100-0	D-267	139,775	174,719	15,510	19,740	277	213	111	55	6.00	(152)
LIB 321	7-021-300-100-0	D-740	209,662	262,078	23,265	29,610	416	320	166	83		
LIB 124H	7-025-100-101-0	D-779	122,960	153,700	13,575	17,275	243	180	90	40		
LIB 224H	7-025-200-101-0	D-371	245,920	307,400	27,150	34,550	487	360	180	80	6.00	(152)
LIB 324H	7-025-300-201-0	-300-900-9	368,880	461,100	40,725	51,825	729	540	270	120		
LIB 127	7-027-100-100-0	D-151	137,509	171,886	15,260	19,420	273	210	109	55		
LIB 227	7-027-200-100-0	D-428	275,018	343,773	30,520	38,840	546	420	218	109	6.50	(165)
LIB 327	6-027-300-100-0	D-689	412,527	515,659	45,780	58,260	819	630	327	164		
LIB 130H	7-031-100-100-0	B-312	261,600	327,000	29,630	37,710	519	380	190	100		
LIB 230H	7-031-200-316-0	B-296	523,200	654,000	59,260	75,420	1,038	760	380	200	7.25	(184)
LIB 330H	7-031-300-304-0	-300-904-9	784,800	981,000	88,890	113,130	1,557	1,140	570	300		
LIB 136	7-036-100-100-0	-100-901-9	406,400	508,000	44,920	57,175	805	600	295	165		
LIB 236	7-036-200-100-0	D-722	812,800	1,016,000	89,840	114,350	1,610	1,200	590	330	9.00	(229)
LIB 336	6-036-300-100-0	-300-900-9	1,219,200	1,524,000	134,760	171,525	2,415	1,800	885	495		
LIB 142	7-042-100-303-0	-100-900-9	580,800	726,000	69,160	81,660	1,150	850	425	235		
LIB 242	7-042-200-311-0	-200-901-9	1,162,240	1,452,800	128,320	163,320	2,300	1,700	850	470	14.00	(355)
LIB 342	6-042-300-302-0	-300-303-9	1,742,400	2,178,000	192,480	244,980	3,450	2,550	1,275	705		
LIB 148	7-048-100-300-0	-100-900-9	1,122,000	1,402,500	118,800	151,200	2,225	1,600	800	455		
LIB 248	7-048-200-300-0	-200-901-9	2,244,000	2,805,000	237,600	302,400	4,450	3,200	1,600	915	18.00	(455)
LIB 348	7-048-300-301-0	-300-900-9	3,366,000	4,207,500	356,400	453,600	6,675	4,800	2,400	1,365		
LIB 260	7-060-200-302-0	-200-901-9	4,760,000	5,950,000	473,000	602,000	9,440	5,950	3,470	1,940		
LIB 360	7-060-300-301-0	-300-901-9	7,140,000	8,925,000	709,000	902,300	14,160	8,925	5,205	2,910	19.00	(480)
LIB 460	6-060-400-300-0	E-236	14,280,000	17,850,000	946,000	1,204,000	18,880	11,900	6,940	3,880		

Maximum Air Pressure is 130 PSI / 9 BAR.

# Air Tube Disc Clutches and Brakes

## Low Inertia Brakes Specifications

Model Size ATD-	Recom- mended Clearance in.	Balance Speed RPM	Hub & C.P.		Swept Area in. <sup>2</sup>	Airtube Volume in. <sup>3</sup> (cm <sup>3</sup> )		Total Brake Wt.		Hub & Center Plate Wt. WR <sup>2</sup> / J=mr <sup>2</sup>			
			Reg- Speed RPM	High Speed RPM*		New	Worn	lb.	(kg)	lb.	(kg)	lb.ft. <sup>2</sup>	(kgm <sup>2</sup> )
LIB 104	1/32	3,325	5,250	5,250*	17	0.9	3.4	11.0	(7)	1.54	(0.7)	0.021	(0.001)
LIB 204	1/16				34	(14.8)	(56)	14.0	(6)	3.88	(1.8)	0.04	(0.002)
LIB 106	1/16-3/32	2,225	3,800	5,700*	39	1.8	11.9	27.5	(12)	6.40	(2.9)	0.24	(0.010)
LIB 206	3/32-5/32				78	(30)	(195)	40.5	(18)	12.17	(5.5)	0.46	(0.019)
LIB 108	1/16-1/8				56			62	(28)	11	(5.0)	0.54	(0.023)
LIB 208	3/32-5/32	1,675	2,870	4,300*	112	3.4	18.3	70	(32)	19	(8.6)	1.00	(0.042)
LIB 308	1/8-3/16				168	(56)	(300)	87	(39)	28	(12.7)	2.00	(0.084)
LIB 111	1/16-1/8				114			130	(59)	23	(10.4)	2.30	(0.097)
LIB 211	3/32-5/32	1,200	2,090	3,125*	228	5.5	30.5	166	(75)	45	(20.4)	4.50	(0.190)
LIB 311	1/8-3/16				342	(90)	(500)	208	(94)	121	(54.9)	7.00	(0.295)
LIB 114	1/16-1/8				158			184	(83)	46	(20.9)	5.7	(0.240)
LIB 214	3/32-5/32	950	1,640	2,450*	316	7.6	42.7	233	(106)	77	(34.9)	11.0	(0.464)
LIB 314	1/8-3/16				474	(125)	(700)	290	(132)	121	(54.9)	16.7	(0.704)
LIB 116	1/16-1/8				228			254	(115)	59	(26.8)	10.2	(0.430)
LIB 216	3/32-5/32	835	1,430	2,150*	455	9.8	56.1	326	(148)	106	(48.1)	19.6	(0.826)
LIB 316	1/8-3/16				683	(161)	(919)	358	(162)	151	(68.5)	29.6	(1.248)
LIB 118	1/16-1/8				264			311	(141)	73	(33.1)	15.0	(0.632)
LIB 218	3/32-5/32	750	1,270	1,910*	528	15.3	85.4	377	(171)	120	(54.4)	28.8	(1.214)
LIB 318	1/8-3/16				792	(251)	(1,400)	461	(209)	180	(81.6)	43.2	(1.821)
LIB 121	3/32-5/32				362			460	(209)	116	(52.6)	32	(1.35)
LIB 221	1/8-3/16	650	1,090	1,650*	724	18.3	97.6	575	(261)	198	(89.8)	61	(2.57)
LIB 321	5/32-7/32				1,086	(300)	(1,599)	723	(328)	312	(141.5)	122	(5.14)
LIB 124H	3/32-5/32				574			618	(280)	132	(60.0)	56	(2.4)
LIB 224H	1/8-3/16	550	950	1,410*	1,148	29.9	159	840	(381)	260	(117.9)	110	(4.6)
LIB 324H	5/32-7/32				1,722	(490)	(2,606)	1,025	(465)	379	(172.0)	160	(6.8)
LIB 127	3/32-5/32				730			760	(345)	187	(84.8)	98	(4.1)
LIB 227	1/8-3/16	500	850	1,250*	1,460	29.9	159	924	(419)	329	(149.2)	191	(8.1)
LIB 327	5/32-7/32				2,190	(490)	(2,606)	1,112	(504)	555	(251.7)	285	(12.0)
LIB 130H	3/32-5/32				827			972	(441)	298	(135.2)	189	(8.0)
LIB 230H	1/8-3/16	450	765	1,130*	1,654	58.6	311	1,350	(612)	546	(247.7)	370	(15.6)
LIB 330H	5/32-7/32				2,481	(960)	(5,096)	1,751	(794)	810	(367.4)	477	(20.1)
LIB 136	3/32-5/32				1,150			1,388	(630)	461	(209.1)	372	(15.7)
LIB 236	1/8-3/16	375	640	950*	2,300	110	415	1,993	(904)	708	(321.1)	725	(30.6)
LIB 336	5/32-7/32				3,450	(1,803)	(6,801)	2,610	(1,184)	1,134	(514.4)	1,091	(46.0)
LIB 142	5/32-7/32				1,400			1,967	(892)	680	(308)	705	(30)
LIB 242	3/16-1/4	325	545	805*	2,800	128	488	2,732	(1,239)	1,197	(543)	1,385	(58)
LIB 342	7/32-9/32				4,200	(2,098)	(7,997)	3,704	(1,680)	1,324	(601)	1,809	(76)
LIB 148	1/8-1/4				2,010			3,158	(1,432)	1,101	(499)	1,785	(75)
LIB 248	5/32-7/32	275	475	705*	4,020	217	824	4,700	(2,132)	1,942	(881)	3,335	(141)
LIB 348	3/16-5/16				6,030	(3,550)	(13,500)	6,540	(2,966)	2,950	(1,338)	4,925	(208)
LIB 260	3/16-5/16				7,230			9,453	(4,288)	2,567	(1,164)	7,077	(298)
LIB 360	1/4-3/8	225	380	575*	10,845	513	1,788	11,643	(5,281)	3,870	(1,755)	10,615	(448)
LIB 460	5/16-7/16				14,460	(8,407)	(29,300)	14,500	(6,577)	5,700	(2,585)	15,070	(635)

\* Consult Factory for Special Assembly Number.

# Air Tube Disc Clutches and Brakes

## Low Inertia Brakes

Sizes 8-36

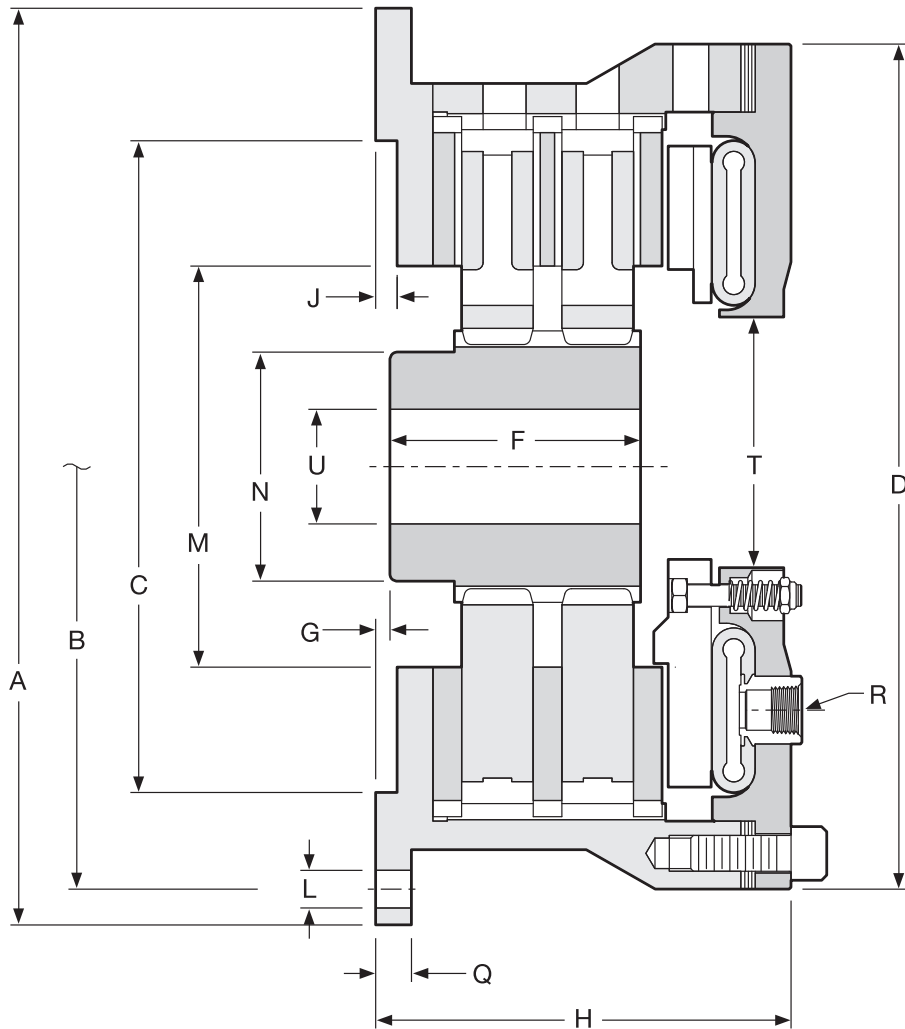



# Air Tube Disc Clutches and Brakes

## Low Inertia Brakes

Sizes 8-36

### Dimensions: inches (mm)

Model Size ATD-	A	B Hole Circle	C Pilot	D	F	G	H
LIB 108	12.13	11.125	8.375 / 8.378	11.13	2.00 (50.8)	.25	4.56 (115.8)
LIB 208	(308.1)	(282.58)	(212.73 / 212.80)	(282.7)	3.25 (82.6)	(6.4)	5.94 (150.9)
LIB 111	16.00	14.750	11.375 / 11.378	14.75	2.75 (69.9)	.13 (3.3)	5.44 (138.2)
LIB 211	(406.4)	(374.65)	(288.93 / 289.00)	(374.7)	4.38 (111.3)	.25 (6.4)	7.19 (182.6)
LIB 114	18.75	17.500	14.375 / 14.378	17.50	3.75 (95.3)	.13 (3.3)	6.06 (153.9)
LIB 214	(476.3)	(444.50)	(365.13 / 365.20)	(444.5)	4.50 (114.3)	.38 (9.7)	8.00 (203.2)
LIB 116					4.00 (101.6)		6.31 (160.3)
LIB 216	21.25	20.000	16.250 / 16.253	20.00	4.75 (120.7)	0.38 (9.7)	8.25 (209.6)
LIB 316	(539.8)	(508.00)	(412.75 / 412.83)	(508.0)	6.63 (168.4)		10.19 (258.8)
LIB 118					4.00 (101.6)		6.69 (169.9)
LIB 218	23.25	22.000	18.250 / 18.253	22.00	4.75 (120.7)	0.44 (11.2)	8.63 (219.2)
LIB 318	(590.6)	(558.80)	(463.55 / 463.63)	(558.8)	6.50 (165.1)		10.63 (270.0)
LIB 121					4.00 (101.6)		7.38 (187.5)
LIB 221	27.00	25.500	21.375 / 21.378	24.88	5.13 (130.3)	.75 (19.1)	9.31 (236.5)
LIB 321	(685.8)	(647.70)	(542.93 / 543.00)	(632.0)	7.13 (181.1)		11.75 (298.5)
LIB 124H					4.00 (101.6)	.69 (17.5)	7.63 (193.8)
LIB 224H	30.00	28.750	24.375 / 24.378	29.00	5.13 (130.3)	.75 (19.1)	9.94 (252.5)
LIB 324H	(762)	(730.25)	(619.13 / 619.20)	(736.6)	7.50 (190.5)	.75 (19.1)	12.25 (311.2)
LIB 127					4.50 (114.3)		7.88 (200.2)
LIB 227	32.75	31.500	27.375 / 27.378	31.00	6.88 (174.8)	0.75 (19.1)	10.38 (263.7)
LIB 327	(831.9)	(800.10)	(695.33 / 695.40)	(787.4)	—	—	—
LIB 130H					5.00 (127.0)	.63 (16.0)	8.38 (212.9)
LIB 230H	37.00	35.500	30.375 / 30.378	34.75	7.13 (181.1)	1.88 (47.8)	11.81 (300.0)
LIB 330H	(939.8)	(901.70)	(771.53 / 771.60)	(882.7)	11.88 (301.8)	.63 (16.0)	15.31 (388.9)
LIB 136	43.50	42.000	36.375 / 36.378	41.00	5.63 (143.0)	0.63	9.50 (241.3)
LIB 236	(1,104.9)	(1,066.80)	(923.93 / 924.00)	(1,041.4)	9.00 (228.6)	(16.0)	12.88 (327.2)

### Dimensions: inches (mm)

Model Size ATD-	J	L		M	N	Q	R		T	U	
		No. -	Size				No. -	Size		Min.	Max.
LIB 108	0.25	6 -	17/32 (13.5)	5.38	3.50	0.50	2 -	1/2 NPT	2.25	1.00	2.00
LIB 208	(6.4)			(136.7)	(88.9)	(12.7)				(25)	(50.8)
LIB 111	0.38	6 -	21/32 (16.7)	7.00	4.00	0.63	2 -	1/2 NPT	3.25	1.00	2.50
LIB 211	(9.7)		11/16 (17.5)	(177.8)	(101.6)	(16.0)				(25)	(63.5)
LIB 114	0.38	8 -	21/32 (16.7)	9.44	5.50	0.63	2 -	1/2 NPT	5.06	1.38	3.50
LIB 214	(9.7)			(239.8)	(139.7)	(16.0)				(35.1)	(88.9)
LIB 116											
LIB 216	0.38	12 -	21/32 (16.7)	10.50	6.00	0.63	2 -	1/2 NPT	6.13	1.38	4.00
LIB 316	(9.7)			(266.7)	(152.4)	(16.0)				(35.1)	(101.6)
LIB 118											
LIB 218	0.38	12 -	21/32 (16.7)	12.50	7.00	0.63	3 -	1/2 NPT	7.75	2.00	4.75
LIB 318	(9.7)			(317.5)	(177.8)	(16.0)				(50.8)	(120.7)
LIB 121											
LIB 221	0.31	12 -	21/32 (16.7)	14.50	9.00	.75	3 -	1/2 NPT	9.25	2.00	6.00
LIB 321	(7.9)			(368.3)	(228.6)	(19.1)				(50.8)	(152.4)
LIB 124H											
LIB 224H	0.25	12 -	21/32 (16.7)	14.50	9.00	.75	3 -	1/2 NPT	13.25	2.00	6.00
LIB 324H	(6.4)			(368.3)	(228.6)	(19.1)				(50.8)	(152.4)
LIB 127											
LIB 227	0.25	16 -	21/32 (16.7)	16.25	9.00	.75	3 -	1/2 NPT	13.25	2.50	6.50
LIB 327	(6.4)			(412.8)	(228.6)	(19.1)				(63.5)	(165.1)
LIB 130H											
LIB 230H	0.25	18 -	25/32 (19.8)	19.25	10.00	.75	4 -	1/2 NPT	15.00	2.50	7.25
LIB 330H	(6.4)			(489)	(254)	(19.1)				(63.5)	(184.2)
LIB 136	0.25	18 -	13/16 (20.6)	23.63	12.00	.88	4 -	1/2 NPT	22.75	6.00	9.00
LIB 236	(6.4)		25/32 (19.8)	(600.2)	(304.8)	(22.4)				(152.4)	(228.6)

**Note:** For mounting, use socket head capscrews conforming to the ASTM-574-97a.  
(Consult factory for drawing before final layout.)

# Air Tube Disc Clutches and Brakes

## Low Inertia Brakes

Sizes 6, 42-60

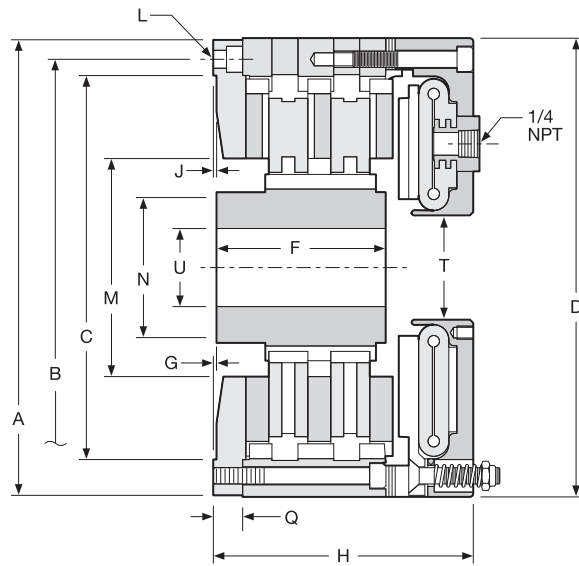

Size 6

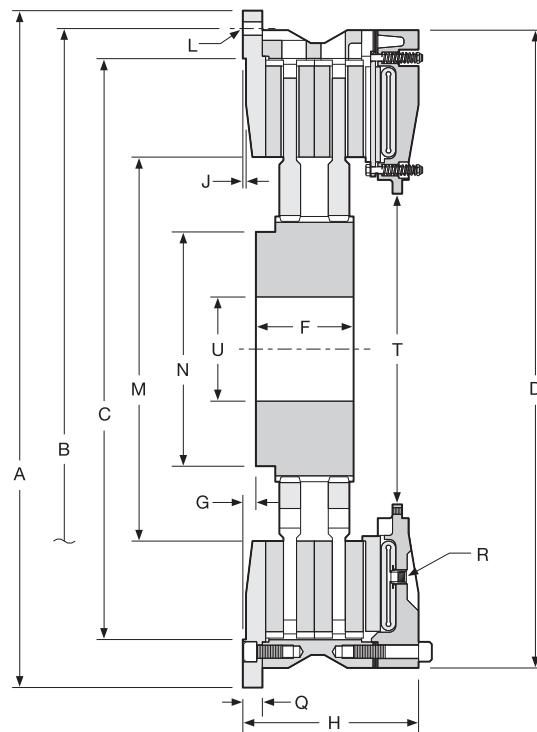

Sizes 42-60

# Air Tube Disc Clutches and Brakes

## Low Inertia Brakes

Sizes 6, 42-60

### Dimensions: inches (mm)

Model Size ATD-	A	B Hole Circle	C Pilot	D	F	G	H
LIB 106	8.75	8.000	7.377 / 7.379	8.81	2.00 (50.8)	0.00 (0.0)	3.75 (95.3)
LIB 206	(222.3)	(203.20)	(187.38 / 187.43)	(223.8)	3.25 (82.6)	0.06 (1.5)	5.00 (127.0)
LIB 142	52.00	49.250	44.625 / 44.628	49.00	5.63 (143.0)	1.00 (25.40)	9.75 (247.7)
LIB 242	(1,320.8)	(1,250.95)	(1,133.48 / 1,133.55)	(1,244.6)	7.50 (190.5)		13.5 (342.9)
LIB 148	61.00	58.000	52.000 / 52.005	56.75	6.00 (152.4)	0.00 (0.0)	10.69 (271.5)
LIB 248	(1,549.4)	(1,473.20)	(1,320.80 / 1,320.93)	(1,441.5)	8.75 (222.3)	1.00 (25.4)	15.06 (382.5)
LIB 260	70.50	74.500	60.000 / 59.990	70.50	9.38 (238.3)	3.50 (88.9)	21.25 (539.8)
LIB 360	(1,790.7)	(1,892.30)	(1,524.0 / 1,523.7)	(1,790.7)	12.25 (311.2)		22.88 (581.2)

### Dimensions: inches (mm)

Model Size ATD-	J	L		M	N	Q	R		T	U	
		No.-	Size				No. -	Size		Min.	Max.
LIB 106	0.06	4 -	0.34 (8.6)	4.19	2.69 (68.3)	0.56	2 -	1/4 NPT	2.00	0.60	2.00
LIB 206	(1.5)			(106.4)		(14.2)			(50.8)	(15.2)	(50.8)
LIB 142	0.25	24 -	1.06 (26.9)	29.50	18.00 (457.2)	1.50	4 -	1/2 NPT	23.88	8.00	14.00
LIB 242	(6.4)			(749.3)		(38.1)			(606.6)	(203.2)	(355.6)
LIB 148	0.25	24 -	1.06 (26.9)	32.00	25.75 (654.1)	1.50	4 -	1/2 NPT	25.25	10.00	18.00
LIB 248	(6.4)			(812.8)		(38.1)			(641.4)	(254.0)	(457.2)
LIB 260	0.38	24 -	2.06 (52.3)	35.50	27.00 (685.8)	3.25	6 -	1/2 NPT	28.5	11.00	19.00
LIB 360	(9.5)			(901.7)	28.15 (715.0)	(797.6)			(723.9)	(279.4)	(482.6)

**Note:** For mounting, use socket head capscrews conforming to the ASTM-574-97a.  
(Consult factory for drawing before final layout.)

B

# Air Tube Disc Clutches and Brakes

## Brake Air Hose Kits

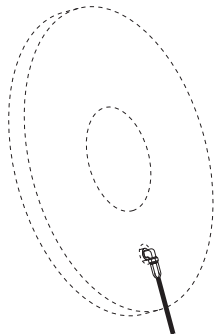

Model	Part Number
8"	8-908-912-100-5 8-908-924-100-5 QRV

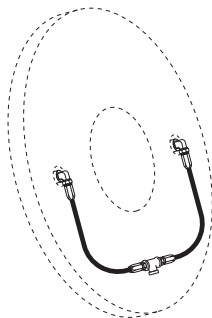

Model	Part Number
6"	8-906-912-200-4 8-906-931-201-5 QRV
8"	8-908-913-200-5 8-908-931-200-5 QRV
11"	8-911-913-200-5 8-911-931-200-5 QRV
14"	8-914-913-200-5 8-914-921-200-5 QRV
16"	8-916-913-200-5 8-916-921-200-5 QRV

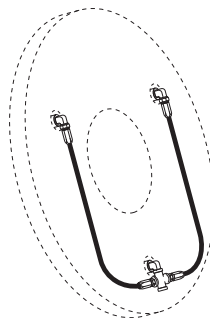

Model	Part Number
18"	8-918-912-200-5 8-918-931-200-5 QRV
21"	8-921-913-200-5 8-921-931-200-5 QRV
24"	8-924-913-200-5 8-924-931-200-5 QRV
27"	8-927-913-200-5 8-927-921-200-5 QRV

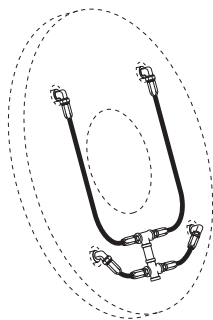

Model	Part Number
30"	8-930-913-400-5 8-930-931-400-5 QRV
36"	8-936-913-400-6 8-936-931-400-6 QRV
42"	8-942-913-400-6 8-924-931-400-6 QRV
48"	8-948-912-400-6 8-948-923-400-6 QRV

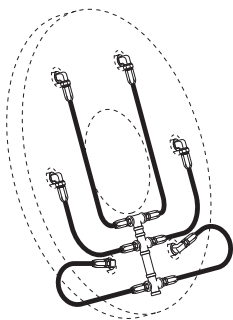

Model	Part Number
60"	8-960-912-500-5 8-960-923-400-6 QRV

Air hose kits contain all necessary parts (fittings, hoses and extensions) to completely plumb the brake air system.

Optional Quick Release Valves can replace elbows on most units (see page 35).

Roto-couplings (see page 35).

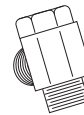

# Air Tube Disc Clutches and Brakes

## Low Inertia Clutches and Brakes

### Component Parts

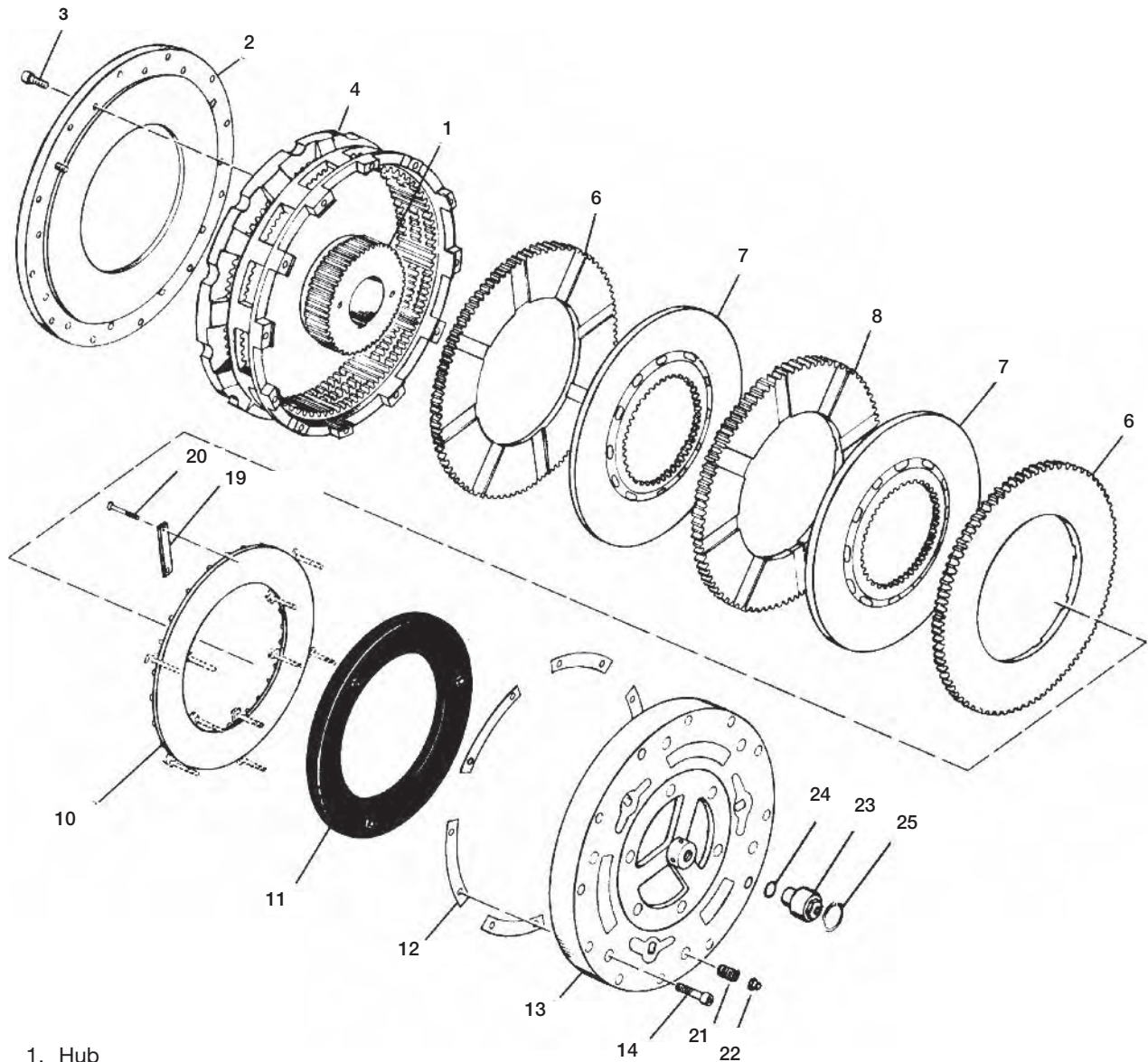

- |   |                           |                     |
|---|---------------------------|---------------------|
| 1. Hub  | 10. Pressure Plate        | 21. Release Springs |
| 2. Demountable Back Plate                           | 11. Airtube               | 22. Flexloc Nuts    |
| 3. Socket Head Capscrews                            | 12. Shims                 | 23. Roto-coupling   |
| 4. Ring   | 13. Airtube Holding Plate | 24. "O" Ring        |
| 6. Grooved Friction Disc<br>(grooved on one side)   | 14. Socket Head Capscrews | 25. Snap Ring       |
| 7. Center Plate                                     | 19. Pressure Plate Lugs   |                     |
| 8. Grooved Friction Disc<br>(grooved on both sides) | 20. Hex Head Capscrews    |                     |



# Air Tube Disc Clutches and Brakes

## High Torque Clutches

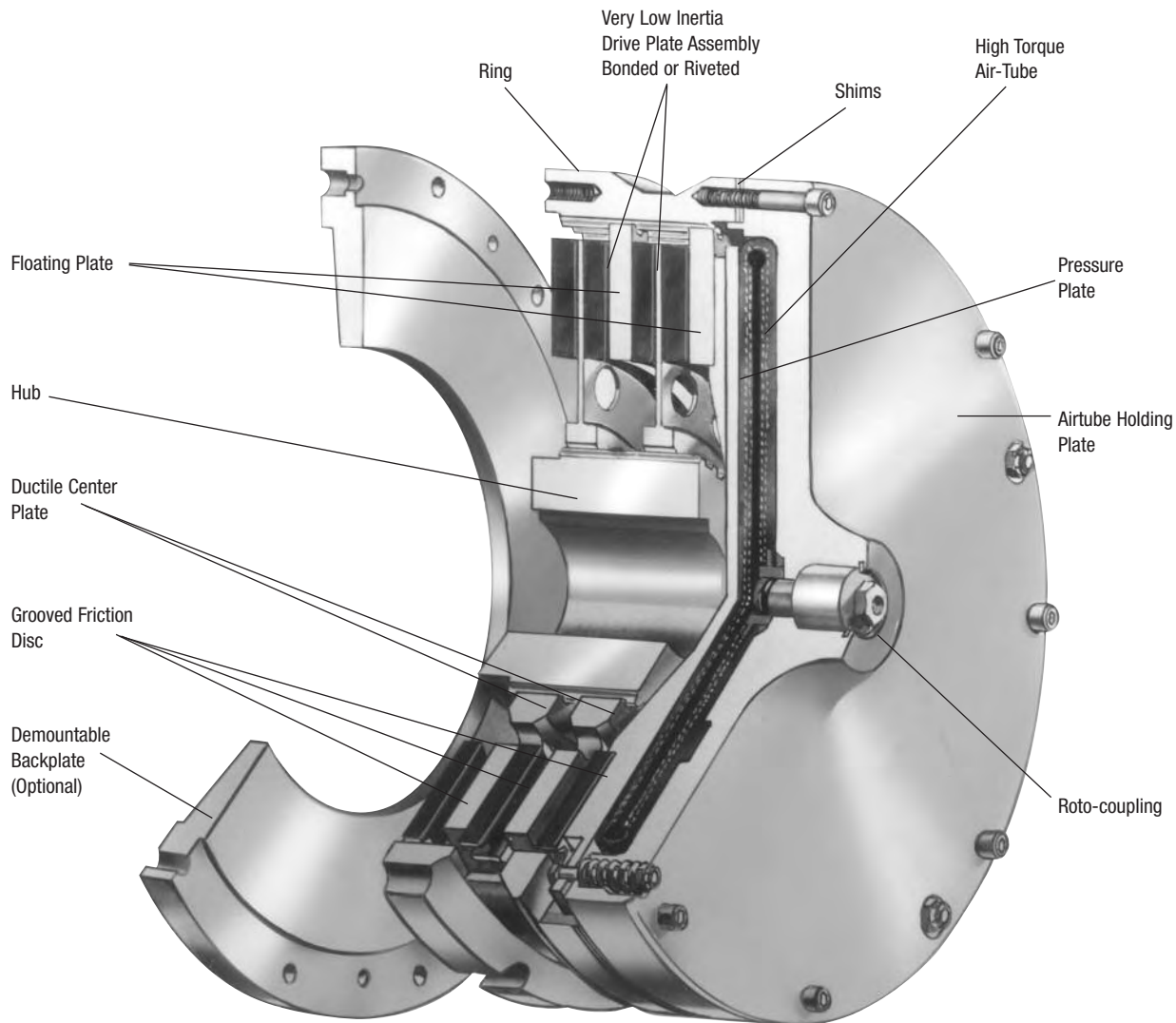

### Selection Requirements

Wichita High Torque Clutches provide the highest torque to size ratios of any Wichita Clutch. They provide smooth controlled starts and stops and are designed for minimum power loss due to low rotating inertia.

- Extremely fast response
- No lubrication
- High torque to size ratio
- Low rotating inertia

To properly select a High Torque Clutch and Low Inertia Brake, the following information must be determined.

1. Torque necessary to do the work (clutch)
2. Rotating inertia to be stopped and started
3. Heat generated by each stop/start
4. Torque necessary to stop inertia (brake)
5. Shaft size

# Air Tube Disc Clutches and Brakes

## Selection Example

### Data

Rated Tonnage . . . . . As Required  
 Crankshaft Speed . . . . . 30 RPM  
 (Continuous Run)  
 Clutch-Brake Shaft RPM . . . . . 204 RPM  
 Crankshaft Speed . . . . . 30 RPM  
 Degrees of Crank to start . . . . . 90°  
 Degrees of Crank to stop . . . . . 90°  
 Connecting Rod Length = b . . . . . 36 in.  
 Stroke . . . . . 6 in.  
 1/2 of Press Stroke (throw) = a . . . . . 3 in.  
 WR<sup>2</sup> of Parts on Backshaft . . . . . 78.2 lb.ft.<sup>2</sup>  
 WR<sup>2</sup> of Parts on Crankshaft . . . . . 39,091 lb.ft.<sup>2</sup>  
 Material Shear Stress . . . . . 45,000 PSI  
 Blade Width . . . . . 60 in.  
 Shaft Size . . . . . 4 in.  
 Maximum Material to be Sheared . . . . . x  
 Air Pressure Available . . . . . 100 PSI

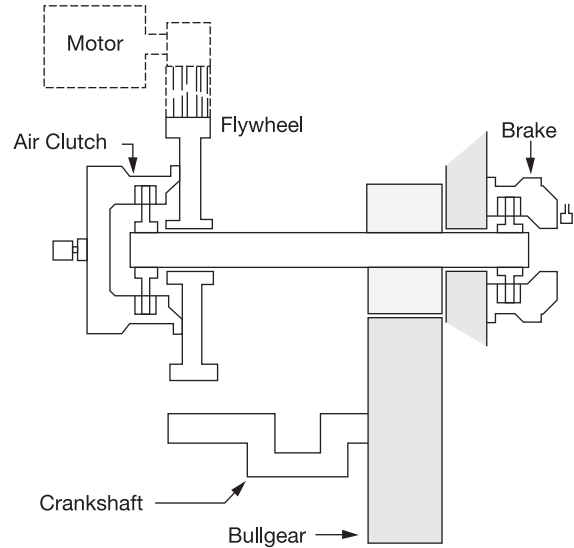

### Calculations

Torque @ Crank  
 = (Material Shear Stress) (x) (Blade Width) (Torque Arm)

Torque arm = y = (x) (tan α)  
 c = a + b - x  
 = 3 + 36 - .25  
 = 38.75 in.

Cos α  
 =  $\frac{b^2 + c^2 - a^2}{2bc}$   
 =  $\frac{(36)^2 + (38.75)^2 - (3)^2}{(2)(36)(38.75)}$   
 = .99948  
 α = 1.8478°

Torque Arm = y = (c) (tan α)  
 = (38.75) (tan 1.8478°)  
 = (38.75) (.03226)  
 = 1.25 in.

Torque @ Crank  
 = (Material Shear Stress) (x) (Blade Width) (Torque Arm)  
 = (45,000) (.25) (60) (1.25)  
 = 843,750 lb.in.

Torque @ Clutch  
 = (Torque @ Crank) ÷  $\frac{\text{Clutch RPM}}{\text{Crankshaft RPM}}$   
 = 843,750 ÷  $\frac{204 \text{ RPM}}{30 \text{ RPM}}$   
 = 124,081 lb.in.

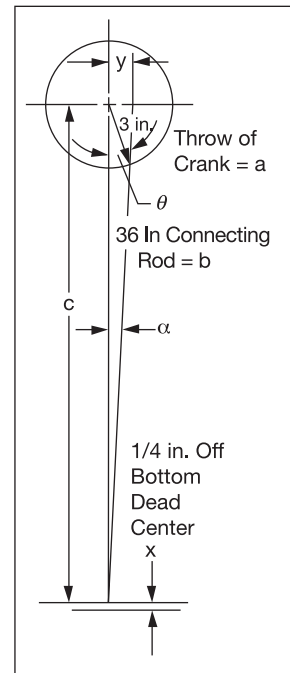

# Air Tube Disc Clutches and Brakes

## High Torque Clutches

### Clutch Selection

Per the application factors on page 23 a "Back Geared Press is 'Group C'."

$$\frac{\text{HP}}{100 \text{ RPM}} = \frac{\text{Torque}}{630} = \frac{124,081}{630} = 197$$

The preliminary clutch selection based on 124,081 lb.in. and 197 HP/100 RPM is an ATD-224 Low Inertia High Torque Clutch. (page 48)

A Low Inertia High Torque Clutch was chosen because of the continuous duty (non-cyclic) operation having a relatively low heat HP requirement.

ATD-224 Low Inertia High Torque Clutch = 280 HP/100 RPM

Rated Torque = 480,000 lb.in @ 100 PSI

Required clutch air pressure is:

$$\text{PSI} = \frac{\text{Clutch required torque} \times (100 \text{ PSI})}{\text{Catalog rated torque @ 100 PSI}}$$

Actual required clutch PSI

$$\text{PSI} = \frac{124,081}{480,000} \times (100 \text{ PSI})$$

= 26 PSI minimum is required.

This application has 100 PSI available.

Contact velocity of rotating disc is:

$$V_c = \frac{(\text{Diameter of Center Plate}) (\pi) (\text{RPM})}{12 \text{ in.ft.}}$$

$$= \frac{24}{12} (\pi) (204) = 1,282 \frac{\text{ft.}}{\text{min.}}$$

(Ductile iron is not required, see page 23).

Maximum bore for ATD-224 High Torque Low Inertia Clutch = 7 in.

Check clutch inflation time for 90° start angle (see page 52, PSI pressure curves)

Estimated time to start

$$= \frac{\text{Start Angle}}{360^\circ} \frac{60}{\text{Crankshaft RPM}}$$

$$= \frac{90^\circ}{360^\circ} \frac{60}{30} = 0.5 \text{ sec.}$$

- P<sub>1</sub> = Line pressure to clutch
- P<sub>2</sub> = Required pressure to clutch
- LN = Natural log
- k = Inflation coefficient (ATD-224 H.T. @ 100 PSI) = 2,600
- u = For ATD-224 H.T. Clutch @ 100 PSI = 2.5

Time to 26% of line pressure.

$$t = \frac{\text{LN} \left[ \frac{P_1}{P_1 - P_2} \right]^{\frac{1}{u}}}{k}$$

$$t = \left[ \frac{\text{LN} \left[ \frac{100}{100 - 26} \right]}{2,600} \right]^{\frac{1}{2.5}}$$

= 0.027 seconds

Clutch will be fully inflated at 90° of crankshaft rotation.

Clutch exhaust time @ 100 PSI = E = .078 (page 52).

#### Note:

This application example is for preliminary sizing only. Contact a Wichita Sales Engineer or the factory for final selection.



# Air Tube Disc Clutches and Brakes

## High Torque Clutches

### Low Inertia Brake Selection

To properly size a brake, the total rotating inertia reflected to the clutch and brake shaft must be known.

Alternate shaft WR<sup>2</sup> referred to clutch shaft

$$= \frac{\text{Alternate shaft WR}^2}{39,091} \left[ \frac{\text{Alternate shaft RPM}}{\text{clutch shaft RPM}} \right]^2$$

$$= \left[ \frac{204}{30} \right]^2$$

WR<sup>2</sup> referred to clutch-brake shaft = 845.4 lb.ft.<sup>2</sup> @204 RPM

Total inertia Back shaft WR<sup>2</sup> = 78.2 lb.ft.<sup>2</sup>

Clutch hub & drive plate WR<sup>2</sup> from Specification Table = 101.0 lb.ft.<sup>2</sup>

Estimate brake WR<sup>2</sup> (assume same as clutch) = 101.0 lb.ft.<sup>2</sup>

Total WR<sup>2</sup> referred to clutch-brake (Estimated) = 1,125.66 lb.ft.<sup>2</sup>

Estimated time to stop:

$$= \left[ \frac{\text{Start Angle}}{360^\circ} \right] \left[ \frac{60}{\text{Crankshaft RPM}} \right]$$

$$= \left[ \frac{90^\circ}{360^\circ} \right] \left[ \frac{60}{30} \right] = .5 \text{ sec.}$$

The deceleration torque is:

$$T = 12 \left[ \frac{\text{WR}^2}{32.2} \right] \left[ \frac{\text{Brake RPM}}{9.5(t)} \right]$$

$$= 12 \left[ \frac{1125.66}{32.2} \right] \left[ \frac{204}{9.5(.5)} \right]$$

Deceleration Torque = 18,015 lb.in.

The HP / 100 RPM for this application is:

$$\frac{\text{HP}}{100 \text{ RPM}} = \frac{\text{Torque (lb.in.)}}{630} = \frac{18,015}{630} = 29 \text{ HP/100 RPM}$$

Consult the Specification Table on pages 36-37 to select a brake based on torque and HP/100 RPM. Under "Duty C", an ATD-214 brake has 32 HP/100 capacity and 55,250 lb.in. torque. The rotating inertia of an ATD-214 Low Inertia Brake is 11 lb.ft.<sup>2</sup>. Therefore, the actual rotating inertia reflected to brake is 1035.6 lb.ft.<sup>2</sup>.

$$\text{The actual deceleration torque} = 12 \left[ \frac{1035.6}{32.2} \right] \left[ \frac{204}{9.5} \right]$$

$$= 16,575 \text{ lb. in.}$$

Required air pressure is:

$$\text{Brake} = \frac{\text{Brake required torque} \times (100 \text{ PSI})}{\text{Catalog rated torque @ 100 PSI}}$$

$$= \frac{16,575 \text{ lb. in.}}{55,250 \text{ lb. in.}} \times 100$$

$$= 30 \text{ PSI minimum}$$

This application has 100 PSI available.

The average heat HP each stop

$$= \frac{(\text{Brake Torque})}{63,000} \times \text{RPM} \times 1/2$$

$$= \frac{16,575}{63,000} \times 204 \times .5$$

$$= 26.8 \text{ HP}$$

$$\text{Friction area necessary to absorb heat} = \frac{\text{Heat HP}}{.7} = \frac{26.8}{.7} = 39 \text{ in.}^2$$

$$= \frac{\text{heat HP}}{\text{Absorbtion rate for .5 sec. (see page 174)}}$$

An ATD-214 Low Inertia Brake has 316 in.<sup>2</sup> of friction lining available to absorb heat generated by stopping. Maximum bore for an ATD-214 Low Inertia Brake is 4-1/8 inches.

Based on the given application data and the following calculations, an ATD-224 Low Inertia High Torque Clutch and ATD-214 Low Inertia Brake have been selected as having sufficient torque and heat dissipation capacity with minimum diameter and sufficient bore capacity.

#### Note:

These application examples are for preliminary sizing only. Contact a Wichita Sales Engineer or the factory for final selection.

# Air Tube Disc Clutches and Brakes

## High Torque Clutches Specifications

Model Size ATD-	Assembly Number	Slip Torque Capacity				Duty Factors HP/100 RPM				Max. Bore Rect. Key	
		lb.in.		Nm		A	B	C	D	in.	(mm)
		80 PSI	100 PSI	5.5 BAR	7 BAR						
HTC 104	6-004-100-400-0	800	1,000	90	113	1.6	1.2	0.6	0.3	1.00	(25)
HTC 204	6-004-200-802-0	1,600	2,000	180	226	3.2	2.4	1.2	0.6		
HTC 106	6-006-100-400-0	4,000	5,000	475	602	8	5.7	2.8	1.4	2.00	(50)
HTC 206	6-006-200-400-0	8,000	10,000	950	1,204	16	11.4	5.7	2.8		
HTC 108	6-008-100-407-0	8,800	11,000	977	1,243	17	13	6	3		
HTC 208	6-008-200-417-0	17,600	22,000	1,953	2,486	34	25	13	6	2.38	(60)
HTC 308	6-008-300-400-0	26,400	33,000	2,930	3,729	51	38	19	9		
HTC 111	6-011-100-408-0	20,000	25,000	2,220	2,825	38	28	14	7		
HTC 211	6-011-200-422-0	40,000	50,000	4,440	5,650	76	56	28	14	2.63	(67)
HTC 311	6-011-300-406-0	60,000	75,000	6,660	8,475	114	84	42	21		
HTC 114	6-014-100-405-0	38,400	48,000	4,261	5,423	75	55	27	14	4.13	(105)
HTC 214	6-014-200-403-0	76,800	96,000	8,522	10,846	160	114	55	28	3.63	(92)
HTC 314	6-014-300-411-0	115,200	144,000	12,783	16,269	225	165	81	42	4.63	(118)
HTC 116	6-016-100-403-0	59,480	74,350	6,600	8,400	118	91	47	24		
HTC 216	6-016-200-402-0	118,960	148,700	13,200	16,800	236	182	94	47	4.00	(102)
HTC 316	6-016-300-401-0	178,440	223,050	19,800	25,200	354	272	142	71		
HTC 118	6-018-100-400-0	84,000	105,000	9,321	11,863	165	120	60	30		
HTC 218	6-018-200-400-0	168,000	210,000	18,642	23,726	330	240	120	60	4.75	(120)
HTC 318	6-018-300-400-0	252,000	315,000	27,963	35,589	495	360	180	90		
HTC 121	6-021-100-400-0	136,000	170,000	15,091	19,207	270	208	108	54		
HTC 221	6-021-200-401-0	272,000	340,000	30,182	38,414	540	415	216	108	6.00	(152)
HTC 321	6-021-300-400-0	408,000	510,000	45,273	57,621	810	623	324	162		
HTC 124	6-024-100-401-0	192,000	240,000	21,305	27,116	385	280	140	70		
HTC 224	6-024-200-405-0	384,000	480,000	42,610	54,232	770	560	280	140	6.00	(152)
HTC 324	6-024-300-401-0	576,000	720,000	63,915	81,348	1,155	840	420	210		
HTC 424	6-024-400-400-0	768,000	960,000	85,220	108,464	1,540	1,120	560	280		
HTC 127	6-027-100-404-0	289,680	362,100	32,144	40,911	575	442	230	115	6.50	(165)
HTC 227	6-027-200-411-0	579,360	724,200	64,288	81,821	1,150	884	460	230		
HTC 327	6-027-300-402-0	869,040	1,086,300	96,432	122,732	1,724	1,326	690	345	6.00	(152)
HTC 130	6-030-100-400-0	376,000	470,000	41,722	53,101	750	535	270	135	7.25	(184)
HTC 230	6-030-200-408-0	752,000	940,000	83,445	106,203	1,500	1,070	540	270		
HTC 330	6-030-300-415-0	1,128,000	1,410,000	125,167	159,304	2,250	1,605	810	405	8.00	(203)
HTC 136	6-036-100-400-0	752,000	940,000	84,445	106,200	1,555	1,120	560	280	8.00	(203)
HTC 236	6-036-200-409-0	1,504,000	1,880,000	166,890	212,400	3,100	2,240	1,120	560		
HTC 336	6-036-300-404-0	2,256,000	2,820,000	250,335	318,600	4,665	3,360	1,680	840	9.25	(235)
HTC 148	6-048-100-400-0	1,888,000	2,360,000	209,500	266,637	3,745	2,690	1,345	670		
HTC 248	6-048-200-406-0	3,776,000	4,720,000	419,000	533,273	7,490	5,380	2,690	1,345	18.00	(455)
HTC 348	6-048-300-403-0	5,664,000	7,080,000	628,500	799,910	11,235	8,070	4,035	2,010		

Maximum Air Pressure is 100 PSI / 7 BAR.

# Air Tube Disc Clutches and Brakes

## High Torque Clutches Specifications

Model Size ATD-	Recom- mended Clearance in.	Balance Speed RPM	Max. Speed		Swept Area in. <sup>2</sup>	Airtube Volume in. <sup>3</sup> (cm <sup>3</sup> )		Total Clutch				Hub & Center Plate			
			Reg- Speed RPM	High Speed RPM*		New	Worn	Wt.		WR <sup>2</sup> / J=mr <sup>2</sup>		Wt.		WR <sup>2</sup> / J=mr <sup>2</sup>	
								lb.	(kg)	lb.ft. <sup>2</sup>	(kgm <sup>2</sup> )	lb.	(kg)	lb.ft. <sup>2</sup>	(kgm <sup>2</sup> )
HTC 104	1/32-1/16	NA	2,100	2,600*	17	1.3	5	11.0	(5)	0.4	(0.018)	1.50	(0.7)	0.021	(0.001)
HTC 204	1/32-1/16	NA	2,100	2,600*	34	(21.3)	(82)	14.0	(6)	0.6	(0.023)	3.88	(1.8)	0.04	(0.002)
HTC 106	1/16-3/32	NA	2,100	2,600*	39	3	14	22.5	(10)	1.4	(0.059)	6.40	(2.9)	0.24	(0.010)
HTC 206	3/32-5/32	NA	2,100	2,600*	78	(49)	(229)	44.2	(20)	3.1	(0.131)	12.60	(5.7)	0.50	(0.021)
HTC 108	1/16-1/8				56	5	30	109.4	(50)	21.43	(0.903)	15	(6.8)	1.35	(0.057)
HTC 208	3/32-5/32	1,675	1,890	2,500*	112	(82)	(492)	148.4	(67)	28.72	(1.211)	30	(13.6)	2.60	(0.110)
HTC 308	1/8-3/16				168			140	(64)	30	(1.265)	40.5	(18.4)	4.00	(0.169)
HTC 111	1/16-1/8				114	8	48	133	(60)	27	(1.14)	23	(10.4)	2.30	(0.097)
HTC 211	3/32-5/32	1,200	1,430	2,200*	228	(131)	(787)	170	(77)	34	(1.43)	45	(20.4)	4.50	(0.190)
HTC 311	1/8-3/16				342			208	(94)	52	(2.19)	121	(54.9)	7.00	(0.295)
HTC 114	1/16-1/8				158	12	75	120	(54)	31	(1.31)	48	(21.8)	5.6	(0.236)
HTC 214	3/32-5/32	950	1,225	1,930*	316	(197)	(1,229)	265	(120)	70	(2.95)	78	(35.4)	11.2	(0.472)
HTC 314	1/8-3/16				474			279	(127)	72	(3.04)	31	(14.1)	15.1	(0.637)
HTC 116	1/16-1/8				228	10	56	236	(107)	84	(3.54)	50	(22.7)	8.2	(0.346)
HTC 216	3/32-5/32	835	1,080	1,700*	455	(164)	(918)	295	(134)	105	(4.43)	107	(48.5)	19.6	(0.826)
HTC 316	1/8-3/16				683			357	(162)	120	(5.06)	151	(68.5)	28.6	(1.206)
HTC 118	1/16-1/8				264	18	101	375	(170)	182	(7.67)	80	(36.3)	15.6	(0.658)
HTC 218	3/32-5/32	750	985	1,530*	528	(295)	(1,655)	485	(220)	200	(8.43)	118	(53.5)	28.8	(1.214)
HTC 318	1/8-3/16				792			530	(240)	250	(10.54)	180	(81.6)	45.0	(1.897)
HTC 121	3/32-5/32				362	38	201	557	(253)	334	(14.08)	101	(45.8)	31	(1.31)
HTC 221	1/8-3/16	650	850	1,400*	724	(623)	(3,294)	697	(316)	427	(18.00)	198	(89.8)	61	(2.57)
HTC 321	5/32-7/32				1,086			757	(343)	400	(16.86)	290	(131.5)	122	(5.14)
HTC 124	3/32-5/32				574			702	(318)	498	(20.99)	134	(60.8)	56	(2.4)
HTC 224	1/8-3/16	550	765	1,210*	1,148	50	250	920	(417)	635	(26.77)	260	(117.9)	110	(4.6)
HTC 324	5/32-7/32				1,722	(819)	(4,097)	1,190	(540)	856	(36.09)	386	(175.1)	163	(6.9)
HTC 424	3/16-1/4				2,296			1,291	(586)	917	(38.66)	466	(211.4)	209	(8.8)
HTC 127	3/32-5/32				730	61	323	989	(449)	785	(33.1)	168	(76.2)	98	(4.1)
HTC 227	1/8-3/16	500	700	1,090*	1,460	(1,000)	(5,293)	1,192	(541)	968	(40.8)	304	(137.9)	191	(8.1)
HTC 327	5/32-7/32				2,190			1,413	(641)	1,183	(49.9)	455	(206.4)	283	(11.9)
HTC 130	3/32-5/32				827	80	395	1,525	(692)	1,836	(77.4)	272	(123.4)	186	(7.8)
HTC 230	1/8-3/16	450	620	1,000*	1,654	(1,311)	(6,473)	1,925	(873)	2,425	(102.2)	529	(240.0)	369	(15.6)
HTC 330	5/32-7/32				2,481			2,240	(1,016)	2,720	(114.7)	800	(362.9)	495	(20.9)
HTC 136	3/32-5/32				1,150			2,190	(993)	3,650	(153.9)	376	(170.6)	368	(15.5)
HTC 236	1/8 -3/16	375	525	800*	2,300	(1966)	(12618)	2,800	(1,270)	4,390	(185.1)	750	(340.2)	755	(31.8)
HTC 336	5/32-7/32				3,450			3,221	(1,461)	4,866	(205.1)	1,206	(547.0)	1,140	(48.1)
HTC 148	1/8-1/4				2,010	200	1,430	7,326	(3,323)	25,703	(1,084)	1,711	(776)	1,828	(77)
HTC 248	7/32-9/32	275	380	580*	4,020	(3,277)	(23,434)	8,497	(3,854)	28,356	(1,195)	1,994	(904)	3,411	(144)
HTC 348	3/16-5/16				6,030			9,768	(4,431)	32,008	(1,349)	2,708	(1,228)	4,899	(207)

\* Consult Factory for Special Assembly Number.

B

# Air Tube Disc Clutches and Brakes

## High Torque Clutches

### Component Parts

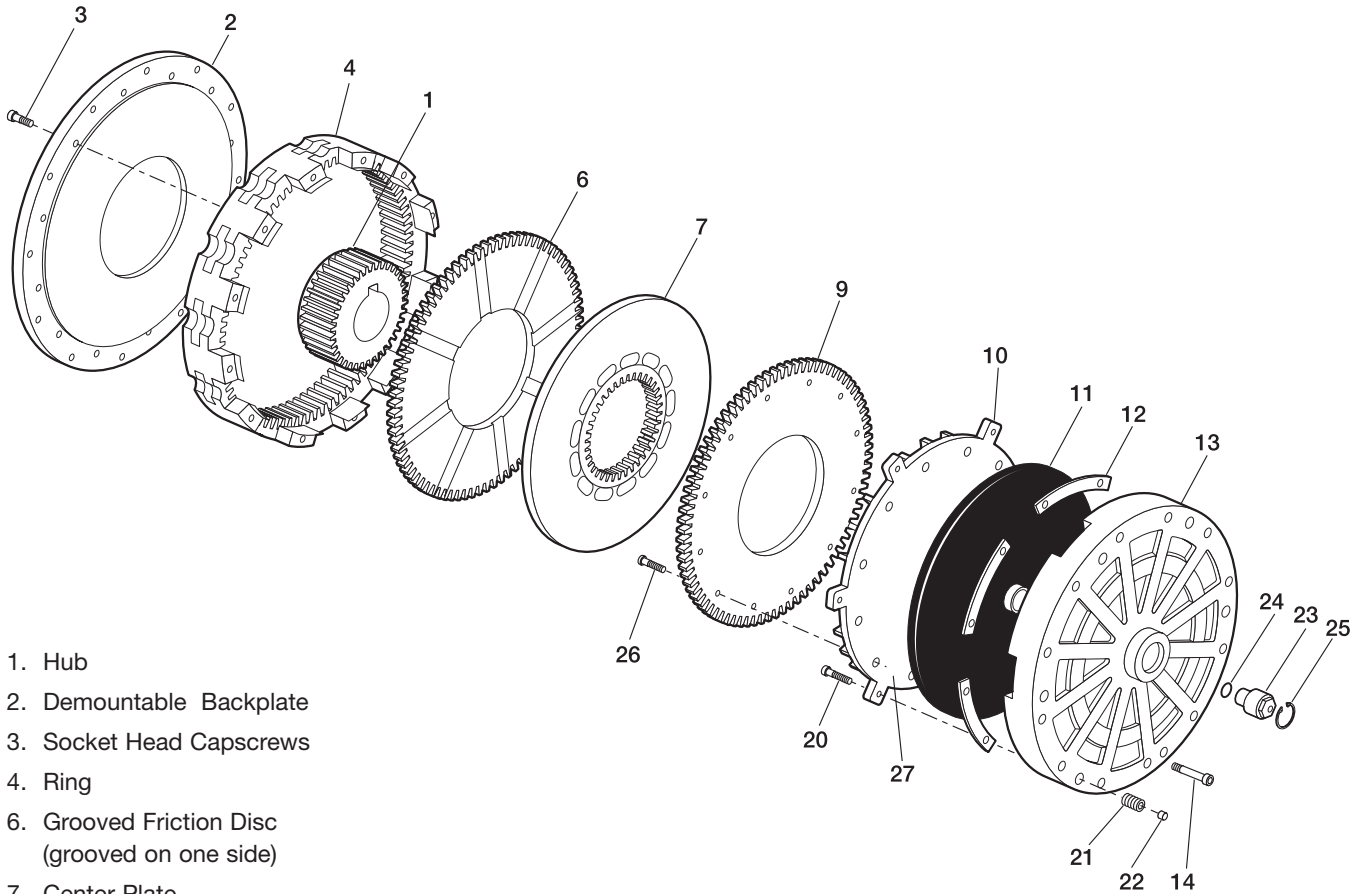

- |   |                              |
|---|------------------------------|
| 1. Hub  |                              |
| 2. Demountable Backplate                          |                              |
| 3. Socket Head Capscrews                          |                              |
| 4. Ring   |                              |
| 6. Grooved Friction Disc<br>(grooved on one side) |                              |
| 7. Center Plate                                   |                              |
| 9. Grooved Friction Disc                          |                              |
| 10. Pressure Plate                                |                              |
| 11. Pancake Air Tube                              |                              |
| 12. Shims   |                              |
| 13. Air Tube Holding Plate                        |                              |
| 14. Socket Head Capscrews                         |                              |
| 20. Hex Head Capscrew                             |                              |
|   | 21. Release Springs          |
|   | 22. Flexloc Nut              |
|   | 23. Internal Roto-Coupling   |
|   | 24. "O" Ring                 |
|   | 25. Snap Ring                |
|   | 26. Flathead Socket Capscrew |
|   | 27. Slotted Flush Nut        |



# Air Tube Disc Clutches and Brakes

## High Torque Clutches

### Inflation Coefficients

Model Size ATD-	Inflation Coefficients Operating Air Pressure					
	50 PSI		75 PSI		100 PSI	
	K	U	K	U	K	U
111	393,000	3	151,000	3	5,100	4
211	393,000	3	151,000	3	5,100	4
114	49,000	3	30,000	3	17,600	3
214	49,000	3	30,000	3	17,600	3
118	5,700	2.8	5,700	2.8	7,500	3
218	5,700	2.8	5,700	2.8	7,500	3
124	10,400	3	5,200	2.7	2,600	2.5
224	10,400	3	5,200	2.7	2,600	2.5
130	940	2.2	1,070	2.2	590	2
230	940	2.2	1,070	2.2	590	2
136	77,000	3.5	58,000	3.5	44,000	3.5
236	77,000	3.5	58,000	3.5	44,000	3.5
148	1,200	2.5	1,240	3.5	800	2.5
248	1,200	2.5	1,240	3.5	800	2.5

### Exhaust Coefficients

Model Size ATD-	Exhaust Coefficients Operating Air Pressure								
	50 PSI			75 PSI			100 PSI		
	R	E	V	R	E	V	R	E	V
111	480,000	.04	4	180,000	.05	4	*	.056	5
211	480,000	.04	4	180,000	.05	4	*	.056	5
114	5,600	.032	2.5	2,200	.044	2.5	910	.064	2.5
214	5,600	.032	2.5	2,200	.044	2.5	910	.064	2.5
118	4,100	.062	3	9,800	.1	4	8,500	.104	4
218	4,100	.062	3	9,800	.1	4	8,500	.104	4
124	280	.06	2	775	.068	2.5	575	.078	2.5
224	280	.06	2	775	.068	2.5	575	.078	2.5
130	690	.072	2.5	500	.083	2.5	500	.084	2.5
230	690	.072	2.5	500	.083	2.5	500	.084	2.5
136	86	.048	1.5	76	.056	1.5	1,100	.064	1.5
236	86	.048	1.5	76	.056	1.5	1,100	.064	1.5
148	160	.11	2.3	120	.136	2.4	111	.15	2.5
248	160	.11	2.3	120	.136	2.4	111	.15	2.5

\* 1.88 x 10<sup>6</sup>

# Air Tube Disc Clutches and Brakes

## Air System Data

### PSI pressure

#### Inflation

Clutch air pressure during inflation can be closely estimated by the following:

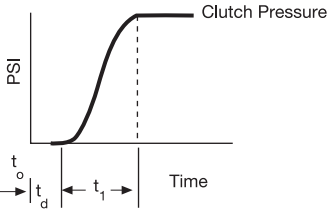

$$t_1 = \left(\frac{3}{K}\right)^{\frac{1}{U}} \text{ sec.} = \text{Time to 95\% Full Inflation}$$

$$\text{Clutch pressure} = P_1 \left(1 - \frac{1}{e^{Kt^U}}\right) \text{ PSI (inflation)}$$

This equation is accurate from 5% up to 95%  $P_1$ .

$P_1$  = Line pressure to clutch PSI

$K$  and  $U$  = coefficients for specific clutch and air pressure from Specification Table on page 51.

$e$  = Napierian base log

$t_o$  = Time at initiation of signal for inflation sec.

$t_d$  = Time delay of air system – sec.

#### Exhaust

Clutch air pressure during exhaust can be closely estimated by the following:

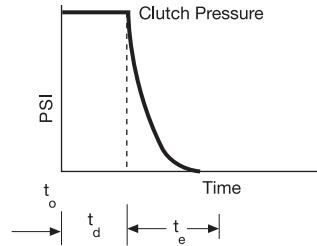

$$\text{Clutch pressure} = (P_1) (R) (E-t)^V \text{ PSI (exhaust)}$$

$R$ ,  $E$  and  $V$  = coefficients for specific clutch and air pressure from Specification Table on page 51.

$t_e$  = Time to exhaust =  $E$  from Specification Table on page 51.

$t$  = Time variable – seconds. In the exhaust equation “ $t$ ” cannot exceed the value of “ $E$ ” sec.

Shown are some of the air systems used on Wichita clutches. These systems are acceptable for remote operation where clutch reaction time is not important. Faster clutch reaction time is accomplished as indicated in the diagram by locating the flow control valve, if required, and the solenoid valve as close as possible to the roto-coupling. Where clutches are located on long shafts, the use of quick release valves on the clutch will facilitate faster clutch response.

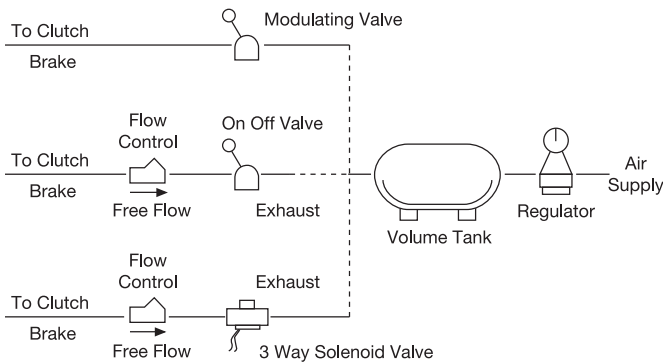

# Air Tube Disc Clutches and Brakes

## Air System Data

PSI pressure

### Overlap

A typical clutch-brake torque curve for a single backshaft press (cyclic application) would appear as shown below.

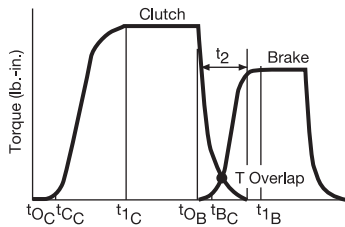

### Time (sec.)

- $t_{Oc}$  = time at which disengaged clutch receives signal
- $t_{Cc}$  = time of clutch engagement
- $t_{1c}$  = time of clutch full inflation
- $t_{Ob}$  = time at which disengaged brake receives signal
- $t_{Bc}$  = time of brake engagement
- $t_{1B}$  = time of brake full exhaust
- $t_2$  = overlap time at which clutch and brake are both engaged

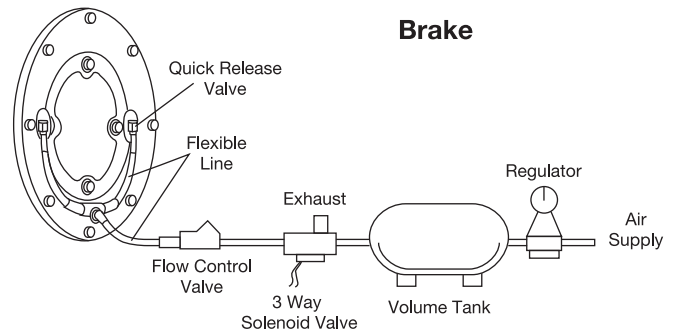
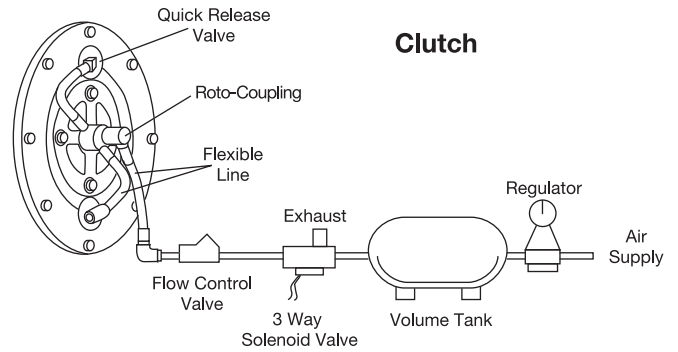

# Air Tube Disc Clutches and Brakes

## High Torque Clutches

Sizes 4-24

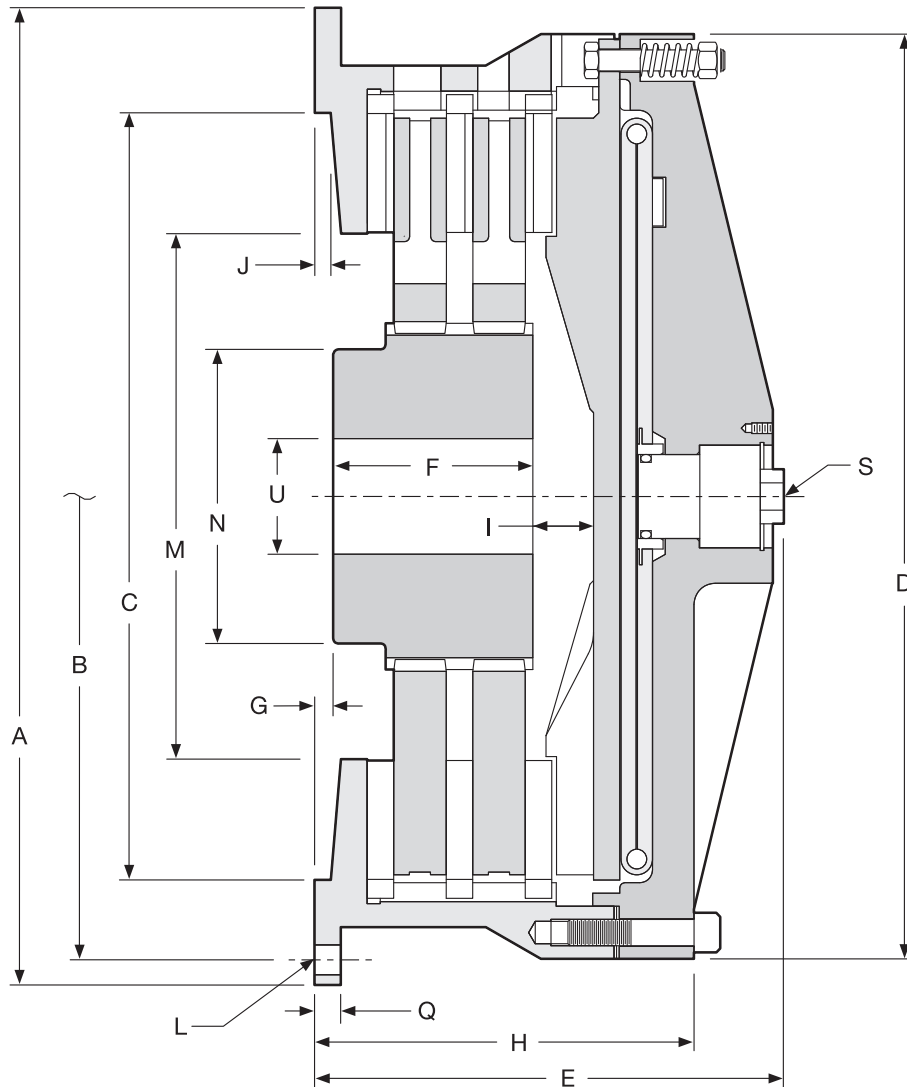



# Air Tube Disc Clutches and Brakes

## High Torque Clutches

### Sizes 4-24

#### Dimensions: inches (mm)

Model Size ATD-	A	B Hole Circle	C Pilot	D	E	F	G	H
HTC 104 <sup>2</sup>	7.38	6.875	4.375 / 4.378	6.38	3.38 (85.9)	1.00 (25.4)	0.06 (1.5)	2.50 (63.5)
HTC 204 <sup>2</sup>	(187.5)	(174.63)	(111.13 / 111.20)	(162.1)	2.50 (63.5)	1.88 (47.8)	0.00 (0.0)	3.19 (81.0)
HTC 106 <sup>3</sup>	8.75	8.000	7.377 / 7.379	8.81	5.03 (127.8)	2.00 (50.8)	0.00 (0.0)	4.53 (115.1)
HTC 206	(222.3)	(203.20)	(187.38 / 187.43)	(223.8)	6.25 (158.8)	3.25 (82.6)	0.06 (1.5)	5.75 (146.1)
HTC 108 <sup>1</sup>	12.13	11.125	8.375 / 8.378	11.13	6.21 (157.7)	1.50 (38.1)	0.50 (12.7)	4.37 (111.0)
HTC 208 <sup>1</sup>	(308.1)	(282.58)	(212.73 / 212.80)	(282.7)	7.52 (191.0)	2.88 (73.2)		5.68 (144.3)
HTC 111 <sup>1</sup>	16.00	14.750	11.375 / 11.378	14.75	7.82 (198.6)	2.00 (950.8)	0.50 (12.7)	5.44 (138.2)
HTC 211 <sup>1</sup>	(406.4)	(374.65)	(288.93 / 289.00)	(374.7)	9.63 (244.6)	3.75 (95.3)		7.25 (184.2)
HTC 114 <sup>1</sup>					8.39 (213.1)	3.75 (95.3)	.13 (3.3)	6.06 (153.9)
HTC 214	18.75	17.500	14.375 / 14.378	17.50	10.50 (266.7)	4.50 (114.3)	.38 (9.7)	7.88 (200.2)
HTC 314 <sup>3</sup>	(476.3)	(444.50)	(365.13 / 365.20)	(444.5)	10.00 (254.0)	4.50 (114.3)	.38 (9.7)	7.88 (200.2)
HTC 116					9.16 (232.7)	2.75 (69.9)		6.78 (172.2)
HTC 216	21.25	20.000	16.250 / 16.253	20.00	11.16 (283.5)	4.75 (120.7)	0.38 (9.7)	8.66 (220.0)
HTC 316	(539.8)	(508.00)	(412.75 / 412.83)	(508.0)	13.06 (331.7)	6.63 (168.4)		10.69 (271.5)
HTC 118					9.28 (235.7)	2.75 (69.9)		7.16 (181.9)
HTC 218	23.25	22.000	18.250 / 18.253	22.00	11.20 (283.5)	4.75 (120.7)	0.44 (11.2)	9.03 (229.4)
HTC 318	(590.6)	(558.80)	(463.55 / 463.63)	(558.8)	12.81 (325.4)	6.50 (165.1)		10.94 (277.9)
HTC 121					10.19 (258.8)	2.88 (73.2)	0.69 (17.5)	7.56 (192.0)
HTC 221	27.00	25.500	21.375 / 21.378	24.88	11.83 (300.5)	5.13 (130.3)	0.75 (19.1)	9.69 (246.1)
HTC 321	(685.8)	(647.70)	(542.93 / 543.00)	(632.0)	14.19 (360.4)	7.13 (181.1)	0.75 (19.1)	12.06 (306.3)
HTC 124					10.06 (255.5)	3.50 (88.9)	0.38 (9.7)	8.38 (212.9)
HTC 224	30.00	28.750	24.375 / 24.378	28.00	12.38 (314.5)	3.50 (88.9)	0.75 (19.1)	10.69 (271.5)
HTC 324	(762.0)	(730.25)	(619.13 / 619.20)	(711.2)	14.69 (373.1)	5.13 (130.3)	0.75 (19.1)	13.00 (330.2)
HTC 424 <sup>3</sup>	29.00	26.75	25.500 / 25.503	28.00	15.64 (397.3)	8.38 (212.9)	0.72 (18.3)	13.81 (350.8)
	(736.6)	(679.5)	(647.70 / 647.78)	(711.2)				

#### Dimensions: inches (mm)

Model Size ATD-	I	J	L		M	N	Q	S	U	
			No. -	Size					Min.	Max.
HTC 104	.38 (9.7)								0.50	1.00
HTC 204	.63 (16)	0.13 (3.3)	6 -	9/32 (7.1)	2.88 (73.2)	2.58 (65.5)	0.38 (9.7)	5/8-18NF	(12.7)	(25)
HTC 106	.94 (23.9)								1.00	2.00
HTC 206	.82 (20.8)	0.06 (1.5)	4 -	11/32 (8.7)	4.19 (106.4)	2.69 (68.3)	0.56 (14.2)	5/8-18NF	(25)	(50.8)
HTC 108	.81 (20.6)								1.00	2.38
HTC 208	.75 (19.1)	0.25 (6.4)	6 -	17/32(13.5)	5.38 (136.7)	3.62 (91.9)	0.50 (12.7)	1/4 NPT	(25)	(60.5)
HTC 111	1.06 (26.9)								1.00	2.63
HTC 211	1.12 (28.4)	0.38 (9.7)	6 -	11/16 (17.5)	7.00 (177.8)	4.12 (104.6)	1.13 (28.7)	1/2 NPT	(25)	(66.8)
HTC 114	1.06 (26.9)	.38 (9.7)		11/16 (17.5)	9.44 (239.8)	5.62 (142.7)	1.13 (28.7)			4.13 (104.9)
HTC 214	.81 (20.6)	.38 (9.7)	8 -	21/32 (16.7)	9.44 (239.8)	5.50 (139.7)	0.63 (16.0)	1/2 NPT	1.38 (35.1)	3.63 (92.2)
HTC 314	.94 (23.9)	.13 (3.3)		5/8-11NC	9.50 (241.3)	6.66 (169.2)	—			4.63 (117.6)
HTC 116	1.25 (31.8)			11/16 (17.5)					1.38	4.00
HTC 216	1.25 (31.8)	0.38 (9.7)	12 -	21/32 (16.7)	10.50 (266.7)	6.00 (152.4)	0.63 (16.0)	1/2 NPT	(35.1)	(101.6)
HTC 316	1.13 (28.7)			21/32 (16.7)						
HTC 118				21/32 (16.7)						
HTC 218	1.44 (36.6)	0.38 (9.7)	12 -	11/16 (17.5)	12.50 (317.5)	7.00 (177.8)	0.63 (16.0)	1/2 NPT	2.00 (50.8)	4.75 (120.7)
HTC 318				21/32 (16.7)						
HTC 121	1.50 (38.1)									
HTC 221	1.31 (33.3)	0.31 (7.9)	12 -	21/32 (16.7)	14.50 (368.3)	9.00 (228.6)	0.75 (19.1)	1/2 NPT	2.00 (50.8)	6.00 (152.4)
HTC 321	1.44 (36.6)									
HTC 124	1.13 (28.7)									
HTC 224	1.38 (35.1)	0.25 (6.4)	12 -	21/32(16.7)	14.50 (368.3)	9.00 (228.6)	0.75 (19.1)	1/2 NPT	2.00 (50.8)	6.00 (152.4)
HTC 324	1.56 (39.6)									
HTC 424 <sup>3</sup>	1.56 (39.6)	0.13 (3.3)	12 -	5/8-11NC	14.50 (368.3)	9.00 (228.6)	—	1/2 NPT	2.00 (50.8)	6.00 (152.4)

**Note:** For mounting, use socket head capscrews conforming to the ASTM-574-97a.

<sup>1</sup> Non-Ventilated center plate, "centerplate is solid".

<sup>2</sup> Drive plate assembly, "friction material is attached to a drive plate".

<sup>3</sup> Less backplate.

(Consult factory for drawing before final layout.)

# Air Tube Disc Clutches and Brakes

## High Torque Clutches

Sizes 27-48

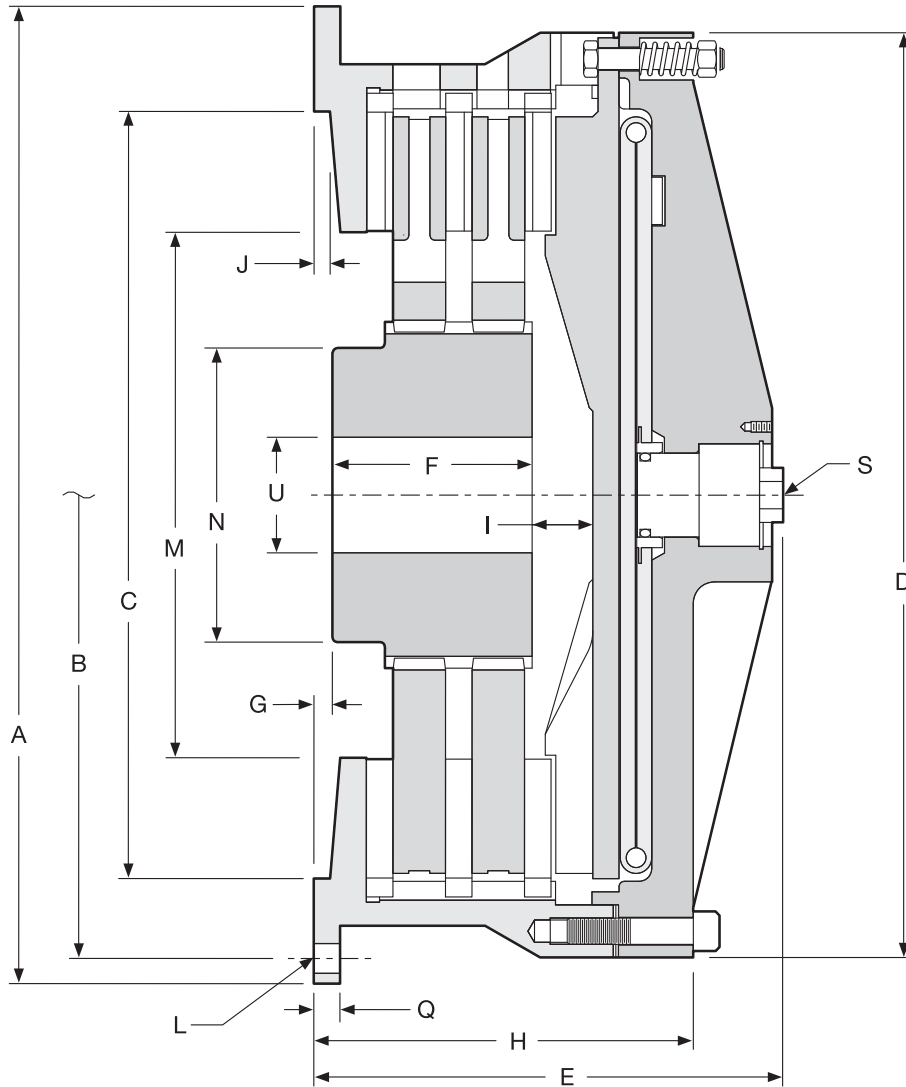

# Air Tube Disc Clutches and Brakes

## High Torque Clutches

### Sizes 27-48

#### Dimensions: inches (mm)

Model Size ATD-	A	B Hole Circle	C Pilot	D	E	F	G	H
HTC 127	32.75	31.500	27.375 / 27.378	31.00	10.34 (262.6)	3.50 (88.9)		8.50 (215.9)
HTC 227	(831.9)	(800.10)	(695.33 / 695.40)	(787.4)	12.75 (323.9)	5.50 (139.7)	0.75 (19.1)	10.91 (277.1)
HTC 327					15.39 (390.9)	7.94 (201.7)		13.34 (338.8)
HTC 130	37.00	35.500	30.375 / 30.378	36.13	11.44 (290.6)	4.25 (108.0)		10.06 (255.5)
HTC 230	(939.8)	(901.70)	(771.53 / 771.60)	(917.7)	14.75 (374.7)	7.50 (190.5)	0.75 (19.1)	13.38 (339.9)
HTC 330					16.25 (412.8)	9.50 (241.3)		15.13 (384.3)
HTC 136	43.50	42.000	36.375 / 36.378	41.50	11.88 (301.8)	4.13 (104.9)	1.13 (28.7)	11.63 (295.4)
HTC 236	(1,104.9)	(1,066.80)	(923.93 / 924.00)	(1,054.1)	15.31 (388.9)	7.50 (190.5)	1.13 (28.7)	15.06 (382.5)
HTC 336					18.75 (476.3)	10.75 (273.1)	1.25 (31.8)	18.50 (469.9)
HTC 148	61.00	58.000		59.00	26.44(671.6)	6.00 (152.4)	1.00 (25.4)	17.13 (435.1)
	(1,525.0)	(1,473.2)		(1,498.6)				
HTC 248	62.00	60.000	52.000 / 52.005	57.00	30.12 (765.0)	8.75(222.3)	1.75 (44.5)	20.81(528.6)
	(1,574.8)	(1,524.0)	(1,320.8 / 1,320.9)	(1,447.8)				
HTC 348 <sup>1</sup>	61.00	58.000		59.00	23.44 (595.4)	12.63 (320.8)	0.00 (0.0)	23.44 (595.4)
	(1,525.0)	(1,473.2)		(1,498.6)				

#### Dimensions: inches (mm)

Model Size ATD-	I	J	L		M	N	Q	S	U	
			No. -	Size					Min.	Max.
HTC 127	1.50 (38.1)					10.50 (266.7)		1/2 NPT		6.50 (165.1)
HTC 227	1.63 (41.4)	0.25 (6.4)	16 -	21/32 (16.7)	16.25 (412.8)	10.50 (266.7)	.75 (19.1)	1 NPT	2.50 (63.5)	6.50 (165.1)
HTC 327	1.63 (41.4)					9.00 (228.6)		1-1/2 -12NF		6.00 (152.4)
HTC 130	1.38 (35.1)					11.00 (279.4)		1/2 NPT		7.25 (184.2)
HTC 230	1.38 (35.1)	0.25 (6.4)	18 -	25/32 (19.8)	19.25 (489)	11.00 (279.4)	.75 (19.1)	1/2 NPT	2.50 (63.5)	7.25 (184.2)
HTC 330	1.00 (25.4)					12.00 (304.8)		1-1/2 -12NF		8.00 (203.2)
HTC 136						12.00 (304.8)				8.00 (203.2)
HTC 236	1.50 (38.1)	0.25 (6.4)	18-	1-1/32 (26.2)	23.63 (600.2)	12.00 (304.8)	1.50 (38.1)	1/2 NPT	6.00 (152.4)	8.00 (203.2)
HTC 336						14.00 (355.6)				9.25 (235.0)
HTC 148	2.70 (68.6)	0.25 (6.4)	24 -	1-1/16 (27.0)	32.00 (812.8)	25.75 (654.1)	1.75 (44.5)	2 NPT	6.00 (152.4)	18.00 (457.2)
HTC 248	3.44 (87.4)						1.50 (38.1)			
HTC 348 <sup>1</sup>	3.96 (100.6)	0.23 (5.8)	24 -	1-9/32 (32.5)	31.88 (809.8)	24.00 (609.6)	1.50 (38.1)	2-1/2 NPT	6.00 (152.4)	18.00 (457.2)

**NOTE:** For mounting, use socket head capscrews conforming to the ASTM-574-97a.

<sup>1</sup> Less backplate.

(Consult factory for drawing before final layout.)

# Air Tube Disc Clutches and Brakes

## Spring-Set Air Release Brakes

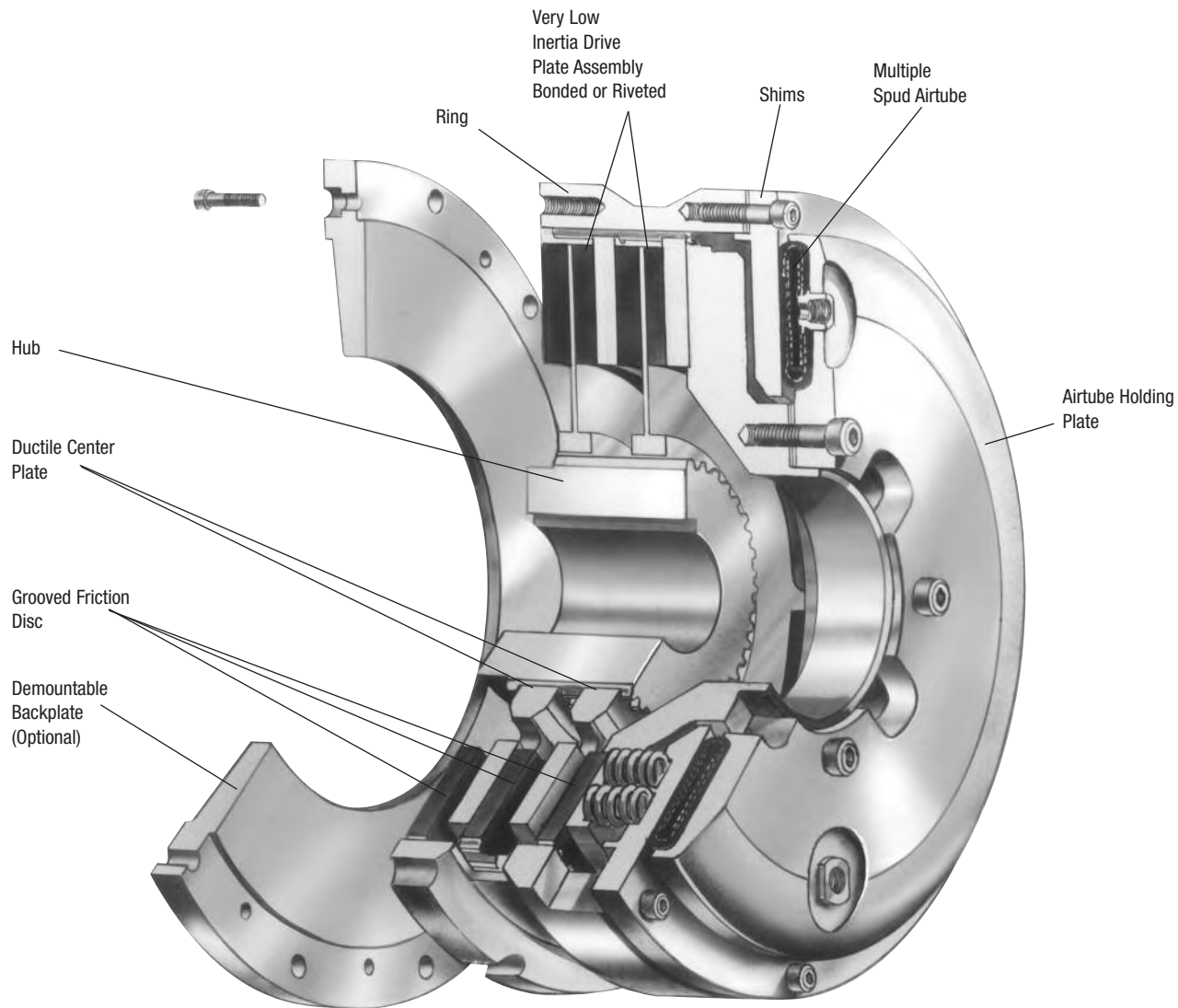

Wichita Spring-Set Air Release Brakes are ideal for fail safe protection of process equipment. Constructed of high strength cast iron, this improved design has thick friction discs for longer wear life. The fast acting air-tube design assures quick, smooth stops.

- No lubrication
- No adjustment
- Available in vertical mount
- Quick, simple installation
- Explosion proof design

### Selection requirements

The selection of a Low Inertia Brake is based on:

1. Torque required to stop a load
2. Friction area necessary to absorb rotational energy
3. Contact velocity of rotating discs
4. Maximum bore capacity of unit

# Air Tube Disc Clutches and Brakes

## Spring-Set Air Release Brakes Selection

### Low Inertia Spring-Set Brake

To properly select a brake, the total rotating inertia,  $WR^2$ , must be reflected to the brakeshaft.

#### Application Data:

Refer to page 45, except, cyclic operation—7 CPM, and 218 Very Low Inertia Clutch.

Alternate Shaft  $WR^2$  referred to clutch shaft =

$$(\text{Alternate Shaft } WR^2) \left( \frac{\text{Alternate Shaft RPM}}{\text{Clutch Brake Shaft RPM}} \right)^2$$

$WR^2$  referred to clutch-brake shaft

$$= (39,091) \left( \frac{30}{204} \right)^2$$

$WR^2$  referred to clutch-brake shaft  
= 845.4 lb.ft.<sup>2</sup> @ 204 RPM

Crank Shaft  $WR^2$  = 845.4 lb.ft.<sup>2</sup>

Clutch-Brake Shaft  $WR^2$  = 78.2 lb.ft.<sup>2</sup>

Clutch Hub and Drive Plate  $WR^2$   
from Specification Table = 14.7 lb.ft.<sup>2</sup>  
(page 61)

Est. Brake  $WR^2$  = 14.7 lb.ft.<sup>2</sup>

Est. Total  $WR^2$  = 953.0 lb.ft.<sup>2</sup>

#### Brake Selection:

Stopping angle of crank shaft = 120° =  $\varnothing_b$   
Use 90° for calculation

#### Estimated time to stop:

$$t = \left( \frac{\varnothing_b}{360^\circ} \right) \left( \frac{60}{\text{crank shaft RPM}} \right)$$

$$= \left( \frac{90}{360} \right) \left( \frac{60}{30} \right) = .5 \text{ sec.}$$

Deceleration Torque

$$= (12) \left( \frac{WR^2}{32.2} \right) \left( \frac{\text{clutch-brake RPM}}{(9.5) (t)} \right)$$

$$= (12) \left( \frac{953}{32.2} \right) \left( \frac{204}{(9.5) (.5)} \right)$$

= 15,250 lb.in.

HP/100 RPM

$$= \frac{15,250}{630} = 24 \text{ HP/100 RPM}$$

#### From duty chart (page 23) “Group B” for spring-set brake (SS):

214 SS Brake is rated @ 28 HP/100 RPM  
90% torque rating = 24,800 lb.in.

$WR^2$  of 214 SS VLI Brake = 4.5 lb.ft.<sup>2</sup>, therefore  
deceleration torque calculation is correct.

\*Average heat horsepower to clutch & brake.

$$\text{Avg. heat HP} = \frac{(\text{Total } WR^2) (\text{RPM}^2) (\text{CPM})}{1.9 \times 10^8}$$

$$= \frac{(953) (41,616) (7)}{1.9 \times 10^8} = 1.45 \text{ HP}$$

\*Check with factory for heat capacity.

#### Note:

This application example is for preliminary sizing only. Contact a Wichita Sales Engineer or the factory for final selection.

B

# Air Tube Disc Clutches and Brakes

## Spring-Set Brakes

### Specifications

Model Size ATD-	Assembly Number 60 PSI Release	Slip Torque Capacity						Max. Bore Rect. Key	
		60 PSI	lb.in. 75 PSI	90 PSI	4.1 BAR	Nm 5.2 BAR	6.2 BAR	in.	(mm)
SSB 104H	71104-730*	451			51			1.00	(25)
SSB 106	7-106-100-200-0	2,225	2,900	3,700	251	328	418		
SSB 206	7-106-200-200-0	4,300	5,600	7,200	486	633	813	2.00	(50)
SSB 306	7-106-300-100-0*	5,750	7,400	9,050	650	836	1,022		
SSB 108	7-108-100-123-0	3,700	4,800	6,200	418	542	700		
SSB 208	7-108-200-121-0	7,100	9,100	12,000	802	1,028	1,356	2.25	(57)
SSB 308	7-108-300-101-0	8,800	11,300	13,400	994	1,277	1,514		
SSB 111	7-111-100-102-0	8,200	10,500	11,600	926	1,186	1,311		
SSB 211	7-111-200-100-0	15,600	20,000	22,200	1,763	2,260	2,508	2.50	(64)
SSB 311	7-111-300-100-0	19,300	24,900	28,400	2,181	2,813	3,209		
SSB 114	7-114-100-127-0	14,500	18,600	24,700	1,638	2,101	2,791		
SSB 214	7-114-200-103-0	27,600	35,400	46,300	3,118	4,000	5,231	3.50	(89)
SSB 314	7-114-300-100-0	36,000	44,700	53,900	4,067	5,050	6,090		
SSB 116	7-116-100-100-0	19,300	23,800	28,400	2,181	2,689	3,209		
SSB 216	7-116-200-100-0	35,300	44,700	53,400	3,988	5,050	6,033	4.00	(102)
SSB 316	7-116-300-100-0	49,500	62,600	75,000	5,593	7,073	8,474		
SSB 118	7-118-100-100-0	31,400	40,400	51,600	3,548	4,564	5,830		
SSB 218	7-118-200-100-0	60,000	77,000	100,000	6,779	8,700	11,298	4.75	(120)
SSB 318	7-118-300-100-0	80,900	102,000	122,000	9,140	11,524	13,784		
SSB 121	7-121-100-100-0	38,300	47,400	57,400	4,327	5,355	6,485		
SSB 221	7-121-200-100-0	71,700	88,800	107,600	8,101	10,033	12,157	6.00	(152)
SSB 321	7-121-300-101-0	100,200	124,100	150,400	11,321	14,021	16,992		
SSB 124H	7-125-100-100-0	75,500	86,600	—	8,530	9,784	—		
SSB 224H	7-125-200-100-0	137,000	161,200	—	15,478	18,213	—	6.00	(152)
SSB 324H	7-125-300-100-0	178,900	223,600	—	20,212	25,263	—		
SSB 127	7-127-100-105-0	75,300	94,200	113,400	8,508	10,643	12,812		
SSB 227	7-127-200-118-0	140,900	176,200	212,100	15,919	19,907	23,963	6.50	(165)
SSB 327	7-127-300-102-0	196,700	245,900	296,000	22,223	27,782	33,443		
SSB 130H	7-131-100-101-0	162,200	211,700	260,500	18,326	23,918	29,432		
SSB 230H	7-131-200-100-0	310,000	404,500	495,500	35,024	45,701	55,982	7.25	(184)
SSB 330H	7-131-300-305-0	395,500	496,100	589,900	44,684	56,050	66,648		
SSB 136H	7-137-100-100-0	254,500	300,000	400,000	28,754	33,894	45,193	9.00	(229)
SSB 236H	7-137-200-104-0	477,500	564,000	760,000	53,949	63,722	85,866	10.00	(254)
SSB 336H	7-137-300-101-0*	675,000	840,100	1,012,600	76,263	94,916	114,405	10.00	(254)
SSB 436H	7-137-400-102-0	868,800	1,081,300	1,303,400	98,158	122,167	147,260	10.00	(254)
SSB 142	7-142-100-302-0	425,000			48,017				
SSB 242	7-142-200-306-0	796,000			89,933			14.00	(355)
SSB 342	7-142-300-301-0	1,072,000			121,116				
SSB 148	7-148-100-300-0	698,250			78,889				
SSB 248	7-148-200-300-0	1,335,000			150,830			18.00	(455)
SSB 348	7-148-300-103-0	1,726,000			195,006				
SSB 260	7-160-200-300-0	3,255,000			367,755				
SSB 360	TBD	4,921,000			555,982			19.00	(480)
SSB 460	TBD	5,355,000			605,016				

\* Not the standard 60 PSI release pressure. See following pages for release pressure per assembly.

# Air Tube Disc Clutches and Brakes

## Spring-Set Brakes Specifications

Model Size ATD-	Recom- mended Clearance in.	Balance Speed RPM	Hub & C.P.		Swept Area in. <sup>2</sup>	Airtube Volume in. <sup>3</sup> (cm <sup>3</sup> )		Total Brake Wt.		Hub & Center Plate Wt. WR <sup>2</sup> / J=mr <sup>2</sup>			
			Reg- Speed RPM	High Speed RPM*		New	Worn	lb.	(kg)	lb.	(kg)	lb.ft. <sup>2</sup>	kgm <sup>2</sup>
SSB 104H	1/32-1/16	3,325	5,250	5,250*	17	0.9	3.4	11.0	(7)	1.54	(0.7)	0.021	(0.001)
SSB 106	1/16-3/32				39	1.8	11.9	27.5	(12)	6.40	(2.9)	0.24	(0.010)
SSB 206	3/32-1/8	2,225	3,800	5,700*	78	(30)	(195)	40.5	(18)	12.17	(5.5)	0.46	(0.019)
SSB 306	3/32-1/8				117								
SSB 108	1/16-1/8				56	3.4	18.3	62	(28)	11	(5.0)	0.54	(0.023)
SSB 208	3/32-5/32	1,675	2,870	4,300*	112	(56)	(300)	70	(32)	19	(8.6)	1.00	(0.042)
SSB 308	1/8-3/16				168			87	(39)	28	(12.7)	2.00	(0.084)
SSB 111	1/16-1/8				114	5.5	30.5	130	(59)	23	(10.4)	2.30	(0.097)
SSB 211	3/32-5/32	1,200	2,090	3,125*	228	(90)	(500)	166	(75)	45	(20.4)	4.50	(0.190)
SSB 311	1/8-3/16				342			208	(94)	121	(54.9)	7.00	(0.295)
SSB 114	1/16-1/8				158	7.6	42.7	184	(83)	46	(20.9)	5.7	(0.240)
SSB 214	3/32-5/32	950	1,640	2,450*	316	(125)	(700)	233	(106)	77	(34.9)	11.0	(0.464)
SSB 314	1/8-3/16				474			290	(132)	121	(54.9)	16.7	(0.704)
SSB 116	1/16-1/8				228	9.8	56.1	254	(115)	59	(26.8)	10.2	(0.430)
SSB 216	3/32-5/32	835	1,430	2,150*	455	(161)	(919)	326	(148)	106	(48.1)	19.6	(0.826)
SSB 316	1/8-3/16				683			358	(162)	151	(68.5)	29.6	(1.248)
SSB 118	1/16-1/8				264	15.3	85.4	311	(141)	73	(33.1)	15.0	(0.632)
SSB 218	3/32-5/32	750	1,270	1,910*	528	(251)	(1,400)	377	(171)	120	(54.4)	28.8	(1.214)
SSB 318	1/8-3/16				792			461	(209)	180	(81.6)	43.2	(1.821)
SSB 121	3/32-5/32				362	18.3	97.6	460	(209)	116	(52.6)	32	(1.35)
SSB 221	1/8-3/16	650	1,090	1,650*	724	(300)	(1,599)	575	(261)	198	(89.8)	61	(2.57)
SSB 321	5/32-7/32				1,086			723	(328)	312	(141.5)	122	(5.14)
SSB 124H	3/32-5/32				574	29.9	159	618	(280)	132	(60.0)	56	(2.4)
SSB 224H	1/8-3/16	550	950	1,410*	1,148	(490)	(2,606)	840	(381)	260	(117.9)	110	(4.6)
SSB 324H	5/32-7/32				1,722			1,025	(465)	379	(172.0)	160	(6.8)
SSB 127	3/32-5/32				730	29.9	159	760	(345)	187	(84.8)	98	(4.1)
SSB 227	1/8-3/16	500	850	1,250*	1,460	(490)	(2,606)	924	(419)	329	(149.2)	191	(8.1)
SSB 327	5/32-7/32				2,190			1,112	(504)	555	(251.7)	285	(12.0)
SSB 130H	3/32-5/32				827	58.6	311	972	(441)	298	(135.2)	189	(8.0)
SSB 230H	1/8-3/16	450	765	1,130*	1,654	(960)	(5,096)	1,350	(612)	546	(247.7)	370	(15.6)
SSB 330H	5/32-7/32				2,481			1,751	(794)	810	(367.4)	477	(20.1)
SSB 136H	3/32-5/32				1,150	110	415	1,388	(630)	461	(209.1)	372	(15.7)
SSB 236H	1/8-3/16	375	640	950*	2,300	(1,803)	(6,801)	1,993	(904)	708	(321.1)	725	(30.6)
SSB 336H	5/32-7/32				3,450			2,610	(1,184)	1,134	(514.4)	1,091	(46.0)
SSB 436H	3/16-1/4				4,600			4,025	(1,826)	1,600	(697)	1,457	(61.4)
SSB 142	5/32-7/32				1,400	128	488	1,967	(892)	680	(308)	705	(30)
SSB 242	3/16-1/4	325	545	805*	2,800	(2,098)	(7,997)	2,732	(1,239)	1,197	(543)	1,385	(58)
SSB 342	7/32-9/32				4,200			3,704	(1,680)	1,324	(601)	1,809	(76)
SSB 148	1/8-1/4				2,010	217	824	3,158	(1,432)	1,101	(499)	1,785	(75)
SSB 248	7/32-9/32	275	475	705*	4,020	(3,550)	(13,500)	4,700	(2,132)	1,942	(881)	3,335	(141)
SSB 348	3/16-5/16				6,030			6,540	(2,966)	2,950	(1,338)	4,925	(208)
SSB 260	3/16-5/16				7,230	513	1,788	9,453	(4,288)	2,567	(1,164)	7,077	(298)
SSB 360	1/4-3/8	225	380	575*	10,845	(8,407)	(29,300)	11,643	(5,281)	3,870	(1,755)	10,615	(448)
SSB 460	5/16-7/16				14,460			14,500	(6,577)	5,700	(2,585)	15,070	(635)

\* Consult Factory for Special Assembly Number.

# Air Tube Disc Clutches and Brakes

## Specifications

Model Size ATD-	Release Pressure		Assembly Number	Duty Factors HP/100 RPM			
	PSI	BAR		A	B	C	D
SSB 104H	65	4.5	71104-730	0.7	0.5	0.3	0.1
	60	4.1	7-106-100-200-0	3	2.3	1.2	0.6
SSB 106	75	5.2	7-106-100-216-0	4	3	1.5	0.8
	90	6.2	7-106-100-217-0	5	3.8	2	1
SSB 206	60	4.1	7-106-200-200-0	6	4.4	2.3	1.1
	75	5.2	7-106-200-205-0	8	5.7	3	1.5
SSB 306	90	6.2	7-106-200-206-0	10	7.4	3.9	2
	80	5.5	7-106-300-100-0	11.7	8.2	4.1	2.1
SSB 108	60	4.1	7-108-100-123-0	5.3	3.8	2	1
	75	5.2	7-108-100-124-0	7	5	2.6	1.3
SSB 208	90	6.2	7-108-100-125-0	9	6.3	3.3	1.6
	60	4.1	7-108-200-121-0	10	7.3	3.8	2
SSB 308	75	5.2	7-108-200-122-0	13	9.3	5	2.5
	90	6.2	7-108-200-110-0	17	12.3	6.5	3.2
SSB 111	60	4.1	7-108-300-101-0	14	9.8	4.9	2.4
	75	5.2	7-108-300-102-0	17.9	12.6	6.3	3.1
SSB 211	90	6.2	7-108-300-103-0	21.3	14.9	7.4	3.7
	60	4.1	7-111-100-102-0	11.7	8.4	4.4	2.2
SSB 311	75	5.2	7-111-100-120-0	15	10.7	5.7	2.8
	90	6.2	7-111-100-121-0	16.6	12	6.3	3.1
SSB 114	60	4.1	7-111-200-100-0	22	16	8.4	4.2
	75	5.2	7-111-200-126-0	28.6	20.5	11.0	5.4
SSB 214	90	6.2	7-111-200-127-0	35.2	24.7	12.3	6.2
	60	4.1	7-111-300-100-0	30.6	21.4	10.7	5.4
SSB 314	75	5.2	7-111-300-103-0	39.5	27.7	13.8	6.9
	90	6.2	7-111-300-104-0	45.1	31.6	15.8	7.9
SSB 116	60	4.1	7-114-100-127-0	20	15	6	4
	75	5.2	7-114-100-101-0	26.6	19	10	5
SSB 216	90	6.2	7-114-100-128-0	35	25	13	6.7
	60	4.1	7-114-200-103-0	39	28	15	7.5
SSB 316	75	5.2	7-114-200-108-0	50	36	19	9.5
	90	6.2	7-114-200-122-0	66	47	25	12.5
SSB 118	60	4.1	7-114-300-100-0	57.1	40	20	10
	75	5.2	7-114-300-104-0	71	49.7	24.8	12.4
SSB 218	90	6.2	7-114-300-105-0	85.6	59.9	29.9	15
	60	4.1	7-116-100-100-0	31	21	11	5
SSB 318	75	5.2	7-116-100-110-0	38	26	13	7
	90	6.2	7-116-100-111-0	45	32	16	8
SSB 104	60	4.1	7-116-200-100-0	56	39	20	10
	75	5.2	7-116-200-116-0	71	50	25	12
SSB 204	90	6.2	7-116-200-117-0	85	59	30	15
	60	4.1	7-116-300-100-0	79	55	28	14
SSB 304	75	5.2	7-116-300-101-0	99	50	25	12
	90	6.2	7-116-300-102-0	119	83	42	21
SSB 106	60	4.1	7-118-100-100-0	45	32	17	8.5
	75	5.2	7-118-100-136-0	58	41	22	11
SSB 206	90	6.2	7-118-100-137-0	74	53	28	14
	60	4.1	7-118-200-100-0	86	61	32	16
SSB 306	75	5.2	7-118-200-148-0	110	79	41	21
	90	6.2	7-118-200-149-0	143	102	54	27
SSB 108	60	4.1	7-118-300-100-0	128	90	45	22
	75	5.2	7-118-300-104-0	162	113	57	28
SSB 208	90	6.2	7-118-300-105-0	194	136	68	34



# Air Tube Disc Clutches and Brakes

## Specifications

Model Size ATD-	Release Pressure		Assembly Number	Duty Factors HP/100 RPM			
	PSI	BAR		A	B	C	D
SSB 121	60	4.1	7-121-100-100-0	61	43	21	11
	75	5.2	7-121-100-106-0	75	53	26	13
	90	6.2	7-121-100-107-0	91	64	32	16
SSB 221	60	4.1	7-121-200-100-0	114	80	40	20
	75	5.2	7-121-200-118-0	141	99	49	25
	90	6.2	7-121-200-119-0	171	120	60	30
SSB 321	60	4.1	7-121-300-101-0	159	111	56	28
	75	5.2	7-121-300-102-0	197	138	69	34
	90	6.2	7-121-300-103-0	239	167	84	42
SSB 124H	60	4.1	7-125-100-100-0	108	77	41	20
	75	5.2	7-125-100-124-0	137	96	48	24
SSB 224H	60	4.1	7-125-200-100-0	196	140	74	37
	75	5.2	7-125-200-134-0	256	179	90	45
SSB 324H	60	4.1	7-125-300-100-0	284	199	99	50
	75	5.2	7-125-300-104-0	355	248	124	62
SSB 127	60	4.1	7-127-100-105-0	120	84	42	21
	75	5.2	7-127-100-100-0	150	105	53	26
	90	6.2	7-127-100-106-0	180	126	63	32
SSB 227	60	4.1	7-127-200-118-0	224	157	78	39
	75	5.2	7-127-200-100-0	280	196	98	49
	90	6.2	7-127-200-119-0	337	236	118	59
SSB 327	60	4.1	7-127-300-102-0	312	219	109	55
	75	5.2	7-127-300-100-0	390	273	137	68
	90	6.2	7-127-300-103-0	470	329	164	82
SSB 130H	60	4.1	7-131-100-101-0	232	166	88	44
	75	5.2	7-131-100-104-0	303	217	115	57
	90	6.2	7-131-100-105-0	372	267	141	70
SSB 230H	60	4.1	7-131-200-100-0	443	318	167	84
	75	5.2	7-131-200-110-0	578	415	218	110
	90	6.2	7-131-200-111-0	710	508	268	134
SSB 330H	60	4.1	7-131-300-305-0	628	439	220	110
	75	5.2	7-131-300-306-0	787	551	276	138
	90	6.2	7-131-300-307-0	936	655	328	164
SSB 136H	60	4.1	7-137-100-100-0	404	283	141	71
	75	5.2	7-137-100-101-0	476	333	167	83
	90	6.2	7-137-100-102-0	635	444	222	211
SSB 236H	60	4.1	7-137-200-104-0	758	531	265	133
	75	5.2	7-137-200-105-0	895	627	313	157
	90	6.2	7-137-200-106-0	1,206	844	422	211
SSB 336H	60	4.1	7-137-300-101-0	917	642	321	160
	75	5.2	7-137-300-102-0	1,155	808	404	202
	90	6.2	7-137-300-103-0	1,381	967	483	242
SBB 436H	60	4.1	7-137-400-102-0	1,616	1,132	564	284
	75	5.2	7-137-400-103-0	1,904	1,332	668	332
	90	6.2	7-137-400-104-0	2,540	1,776	888	444
SSB 142	60	4.1	7-142-100-302-0	610	435	230	115
SSB 242	60	4.1	7-142-200-306-0	1,140	815	430	215
SSB 342	60	4.1	7-142-300-301-0	1,702	1,192	596	298
SSB 148	60	4.1	7-148-100-300-0	1,000	715	375	190
SSB 248	60	4.1	7-148-200-300-0	1,910	1,370	720	360
SSB 348	60	4.1	7-148-300-103-0	2,740	1,918	959	479
SSB 260	60	4.1	7-160-200-300-0	4,650	2,340	1,760	880
SSB 360	60	4.1	—	7,030	4,050	2,660	1,330
SSB 460	60	4.1	—	8,500	5,950	2,975	1,488

# Air Tube Disc Clutches and Brakes

## Low Inertia Spring-Set Brake Component Parts

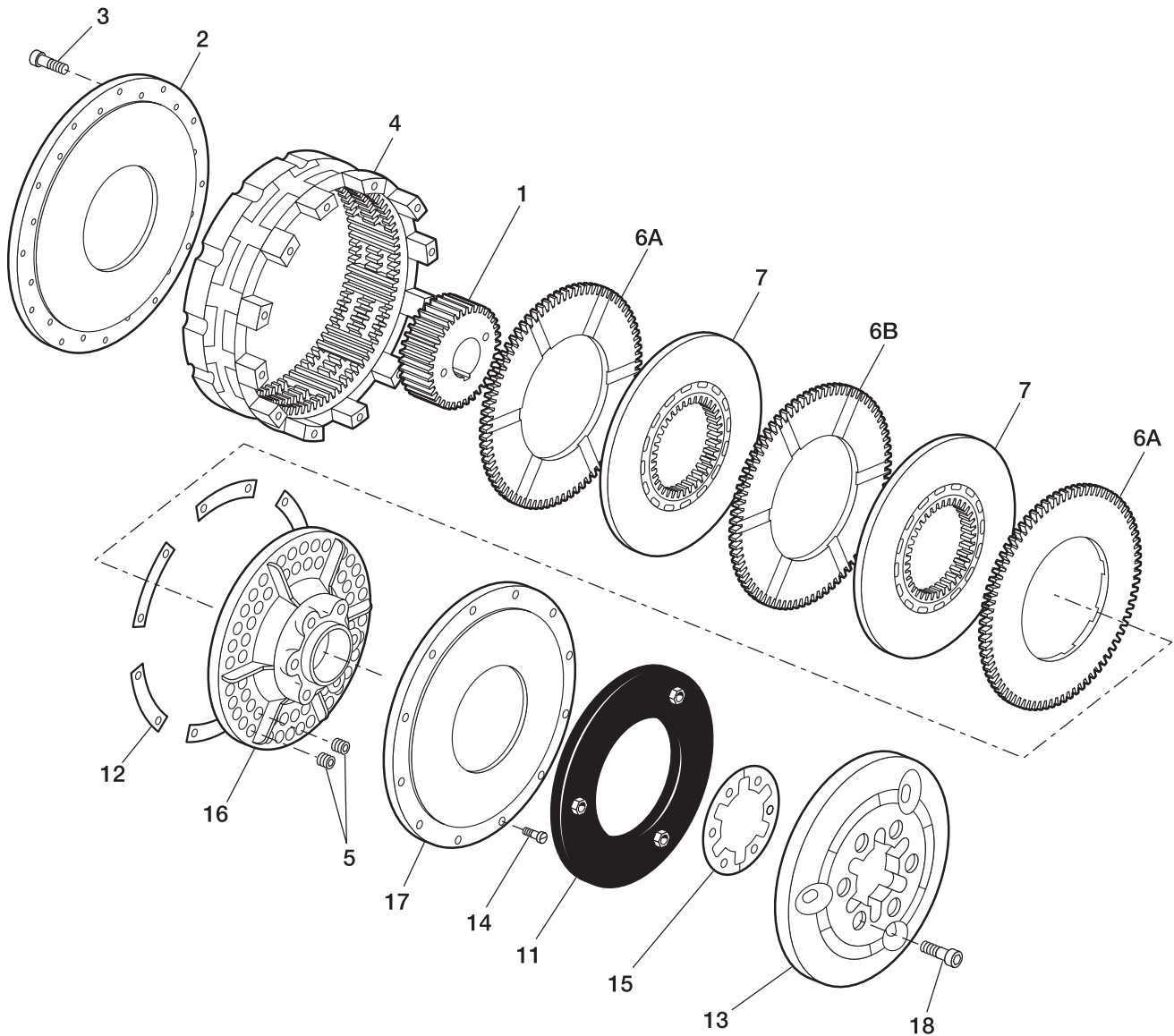

### Component Parts

- |   |                            |
|---|----------------------------|
| 1. Hub  | 11. Airtube                |
| 2. Backplate                                      | 12. O. D. Shims            |
| 3. Socket Head Capscrews                          | 13. Air Tube Holding Plate |
| 4. Ring   | 14. Socket Head Capscrews  |
| 5. Springs  | 15. I.D. Shims             |
| 6A. Grooved Friction Disc (grooved on one side)   | 16. Spring Release Plate   |
| 6B. Grooved Friction Disc (grooved on both sides) | 17. Airtube Spring Plate   |
| 7. Center Plate                                   | 18. Socket Head Capscrews  |

# Air Tube Disc Clutches and Brakes

## Spring-Set Brake Air Hose Kits

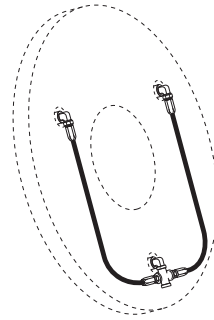
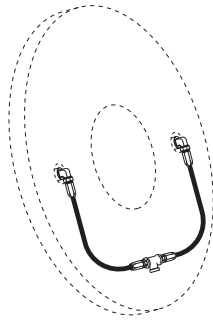
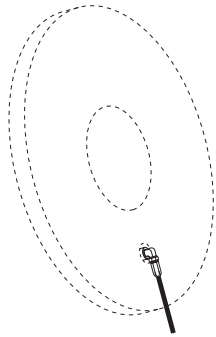

Model	Part Number
8"	8-908-912-100-5 8-908-924-100-5 QRV

Model	Part Number
6"	8-906-912-200-4 8-906-931-201-5 QRV
8"	8-908-913-200-5 8-908-931-200-5
11"	8-911-913-200-5 8-911-931-200-5 QRV
14"	8-914-913-200-5 8-914-921-200-5 QRV
16"	8-916-913-200-5 8-916-921-200-5 QRV

Model	Part Number
18"	8-918-912-200-5 8-918-931-200-5 QRV
21"	8-921-913-200-5 8-921-931-200-5 QRV
24"	8-924-913-200-5 8-924-931-200-5 QRV
27"	8-927-913-200-5 8-927-921-200-5 QRV

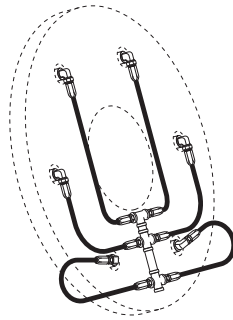
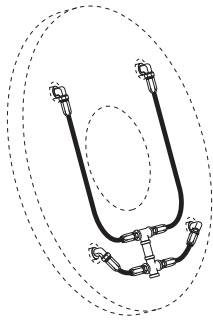

Model	Part Number
30"	8-930-913-400-5 8-930-931-400-5 QRV
36"	8-936-913-400-6 8-936-931-400-6 QRV
42"	8-942-913-400-6 8-924-931-400-6 QRV
48"	8-948-912-400-6 8-948-923-400-6 QRV

Model	Part Number
60"	8-960-912-500-5 8-960-923-400-6 QRV

Air hose kits contain all necessary parts (fittings, hoses and extensions) to completely plumb the brake air system.

Optional Quick Release Valves can replace elbows on most units (see page 121).



# Air Tube Disc Clutches and Brakes

## Spring-Set Brakes (Sizes 4H, 8-36)

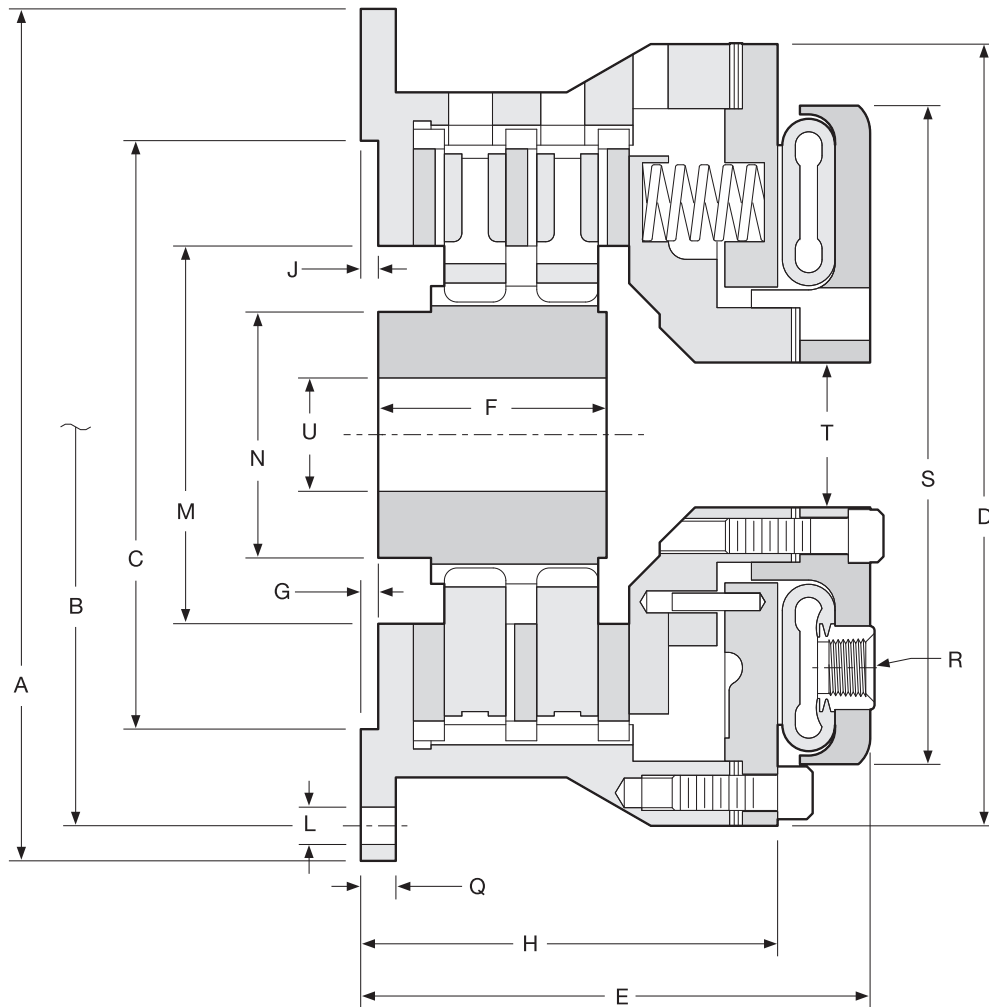

# Air Tube Disc Clutches and Brakes

## Dimensions: inches (mm)

Model	B		C		D	E	F	G	H
Size ATD-	A	Hole Circle	Pilot						
SSB 104H	7.09 (180)	6.496 (165)	5.512 / 5.515 (140.00 / 140.06)		7.09 (180)	4.13 (105)	0.98 (25)	0.06 (1.6)	3.78 (96)
SSB 108	12.13 (308.1)	11.125 (282.58)	8.375 / 8.378 (212.73 / 212.80)		11.13 (282.7)	5.88 (149.4)	2.00 (50.8)	0.25 (6.4)	4.56 (115.8)
SSB 208	16.00 (406.4)	14.750 (374.65)	11.375 / 11.378 (288.93 / 289.00)		14.75 (374.7)	6.56 (166.6)	2.75 (69.9)	0.13 (3.3)	5.44 (138.2)
SSB 111	16.00 (406.4)	14.750 (374.65)	11.375 / 11.378 (288.93 / 289.00)		14.75 (374.7)	6.56 (166.6)	2.75 (69.9)	0.13 (3.3)	5.44 (138.2)
SSB 211	16.00 (406.4)	14.750 (374.65)	11.375 / 11.378 (288.93 / 289.00)		14.75 (374.7)	6.56 (166.6)	2.75 (69.9)	0.13 (3.3)	5.44 (138.2)
SSB 114	18.75 (476.3)	17.500 (444.50)	14.375 / 14.378 (365.13 / 365.20)		17.50 (444.5)	8.00 (203.2)	3.00 (76.2)	0.13 (3.3)	6.00 (152.4)
SSB 214	18.75 (476.3)	17.500 (444.50)	14.375 / 14.378 (365.13 / 365.20)		17.50 (444.5)	9.89 (251.2)	4.50 (114.3)	0.38 (9.7)	7.81 (198.4)
SSB 314	18.75 (476.3)	17.500 (444.50)	14.375 / 14.378 (365.13 / 365.20)		17.50 (444.5)	11.72 (297.7)	6.50 (165.1)	0.38 (9.7)	9.69 (246.1)
SSB 116	21.25 (539.8)	20.000 (508.00)	16.250 / 16.253 (412.75 / 412.83)		20.00 (508.0)	8.25 (209.6)	4.00 (101.6)	0.38 (9.7)	6.00 (152.4)
SSB 216	21.25 (539.8)	20.000 (508.00)	16.250 / 16.253 (412.75 / 412.83)		20.00 (508.0)	10.06 (255.5)	4.75 (120.7)	0.38 (9.7)	7.87 (199.9)
SSB 316	21.25 (539.8)	20.000 (508.00)	16.250 / 16.253 (412.75 / 412.83)		20.00 (508.0)	12.13 (308.1)	6.63 (168.4)	0.38 (9.7)	9.88 (251.0)
SSB 118	23.25 (590.6)	22.000 (558.80)	18.250 / 18.253 (463.55 / 463.63)		22.00 (558.8)	9.00 (228.6)	4.00 (101.6)	0.44 (11.2)	6.56 (166.6)
SSB 218	23.25 (590.6)	22.000 (558.80)	18.250 / 18.253 (463.55 / 463.63)		22.00 (558.8)	10.70 (271.8)	4.75 (120.7)	0.44 (11.2)	8.45 (214.6)
SSB 318	23.25 (590.6)	22.000 (558.80)	18.250 / 18.253 (463.55 / 463.63)		22.00 (558.8)	—	—	—	—
SSB 121	27.00 (685.8)	25.500 (647.70)	21.375 / 21.378 (542.93 / 543.00)		24.88 (632.0)	9.69 (241.6)	4.00 (101.6)	0.75 (19.1)	7.38 (187.5)
SSB 221	27.00 (685.8)	25.500 (647.70)	21.375 / 21.378 (542.93 / 543.00)		24.88 (632.0)	11.88 (301.8)	5.13 (130.3)	0.75 (19.1)	9.57 (243.1)
SSB 321	27.00 (685.8)	25.500 (647.70)	21.375 / 21.378 (542.93 / 543.00)		24.88 (632.0)	—	—	—	—
SSB 124H	30.00 (762)	28.750 (730.25)	24.375 / 24.378 (619.13 / 619.20)		29.00 (736.6)	9.56 (242.8)	4.00 (101.6)	0.75 (19.1)	6.50 (165.1)
SSB 224H	30.00 (762)	28.750 (730.25)	24.375 / 24.378 (619.13 / 619.20)		29.00 (736.6)	11.88 (301.8)	5.13 (130.3)	0.81 (20.6)	9.50 (241.3)
SSB 324H	30.00 (762)	28.750 (730.25)	24.375 / 24.378 (619.13 / 619.20)		29.00 (736.6)	—	—	—	—
SSB 127	32.75 (831.9)	31.500 (800.10)	27.375 / 27.378 (695.33 / 695.40)		31.00 (787.4)	9.94 (252.5)	4.50 (114.3)	0.75 (19.1)	7.69 (195.3)
SSB 227	32.75 (831.9)	31.500 (800.10)	27.375 / 27.378 (695.33 / 695.40)		31.00 (787.4)	12.5 (317.5)	6.88 (174.8)	0.75 (19.1)	10.13 (257.3)
SSB 327	32.75 (831.9)	31.500 (800.10)	27.375 / 27.378 (695.33 / 695.40)		31.00 (787.4)	15.25 (387.4)	7.94 (201.7)	0.75 (19.1)	12.56 (319.0)
SSB 130H	37.00 (939.8)	35.500 (901.70)	30.375 / 30.378 (771.53 / 771.60)		34.75 (882.7)	11.00 (279.4)	5.00 (127.0)	0.63 (16)	8.31 (211.1)
SSB 230H	37.00 (939.8)	35.500 (901.70)	30.375 / 30.378 (771.53 / 771.60)		34.75 (882.7)	14.75 (374.7)	7.13 (181.1)	1.88 (47.8)	11.75 (298.5)
SSB 330H	37.00 (939.8)	35.500 (901.70)	30.375 / 30.378 (771.53 / 771.60)		34.75 (882.7)	—	—	—	—
SSB 136H	43.50 (1,104.9)	42.000 (1,066.80)	36.375 / 36.378 (923.93 / 924.00)		41.00 (1,041.4)	11.75 (298.5)	4.25 (108.0)	0.63 (16)	8.56 (217.4)
SSB 236H	43.50 (1,104.9)	42.000 (1,066.80)	36.375 / 36.378 (923.93 / 924.00)		41.00 (1,041.4)	15.13 (384.3)	9.00 (228.6)	0.63 (16)	12.00 (304.8)
SSB 336H	43.50 (1,104.9)	42.000 (1,066.80)	36.375 / 36.378 (923.93 / 924.00)		41.00 (1,041.4)	19.06 (484.1)	12.38 (314.5)	1.00 (25.4)	15.81 (401.6)

## Dimensions: inches (mm)

Model	J	L		M	N	Q	R		S	T	U	
		No. -	Size				No. -	Size			Min.	Max.
SSB 104H	0.19 (4.7)	4 -	0.35 (9)	2.99 (76)	1.97 (50)	2.13 (54)	2 -	1/8 NPT	7.09 (180)	1.97 (50)	0.60 (15)	1.00 (25)
SSB 108	0.25 (6.4)	6 -	17/32 (13.5)	5.38 (136.7)	3.50 (88.9)	0.50 (12.7)	2 -	1/2 NPT	9.38 (238.3)	2.06 (52.3)	1.00 (25)	2.00 (50.8)
SSB 208	0.25 (6.4)	6 -	17/32 (13.5)	5.38 (136.7)	3.50 (88.9)	0.50 (12.7)	2 -	1/2 NPT	9.38 (238.3)	2.06 (52.3)	1.00 (25)	2.00 (50.8)
SSB 111	0.38 (9.7)	6 -	21/32 (16.7)	7.00 (177.8)	4.00 (101.6)	0.63 (16)	2 -	1/2 NPT	11.94 (303.3)	3.02 (76.7)	1.00 (25)	2.50 (63.5)
SSB 211	0.38 (9.7)	6 -	21/32 (16.7)	7.00 (177.8)	4.00 (101.6)	0.63 (16)	2 -	1/2 NPT	11.94 (303.3)	3.02 (76.7)	1.00 (25)	2.50 (63.5)
SSB 114	0.38 (9.7)	8 -	21/32 (16.7)	9.44 (239.8)	5.50 (139.7)	0.63 (16)	2 -	1/2 NPT	14.38 (365.3)	3.88 (98.6)	1.38 (35.1)	3.50 (88.9)
SSB 214	0.38 (9.7)	8 -	21/32 (16.7)	9.44 (239.8)	5.50 (139.7)	0.63 (16)	2 -	1/2 NPT	14.38 (365.3)	4.25 (108)	1.38 (35.1)	3.50 (88.9)
SSB 314	0.38 (9.7)	8 -	21/32 (16.7)	9.44 (239.8)	5.50 (139.7)	0.63 (16)	2 -	1/2 NPT	14.38 (365.3)	3.88 (98.6)	1.38 (35.1)	3.50 (88.9)
SSB 116	0.38 (9.7)	12 -	11/16 (17.5)	10.50 (266.7)	6.00 (152.4)	0.63 (16)	2 -	1/2 NPT	16.30 (414)	4.38 (111.3)	1.38 (35.1)	4.00 (101.6)
SSB 216	0.38 (9.7)	12 -	11/16 (17.5)	10.50 (266.7)	6.00 (152.4)	0.63 (16)	2 -	1/2 NPT	16.30 (414)	4.38 (111.3)	1.38 (35.1)	4.00 (101.6)
SSB 316	0.38 (9.7)	12 -	11/16 (17.5) 21/32 (16.7)	10.50 (266.7)	6.00 (152.4)	0.63 (16)	2 -	1/2 NPT	16.30 (414)	4.38 (111.3)	1.38 (35.1)	4.00 (101.6)
SSB 118	0.38 (9.7)	12 -	21/32 (16.7)	12.50 (317.5)	7.00 (177.8)	0.63 (16)	3 -	1/2 NPT	19.38 (492.3)	4.88 (124)	2.00 (50.8)	4.75 (120.7)
SSB 218	0.38 (9.7)	12 -	21/32 (16.7)	12.50 (317.5)	7.00 (177.8)	0.63 (16)	3 -	1/2 NPT	19.38 (492.3)	4.88 (124)	2.00 (50.8)	4.75 (120.7)
SSB 318	—	12 -	21/32 (16.7)	12.50 (317.5)	7.00 (177.8)	0.63 (16)	3 -	1/2 NPT	19.38 (492.3)	4.88 (124)	2.00 (50.8)	4.75 (120.7)
SSB 121	0.31 (7.9)	12 -	21/32 (16.7)	14.50 (368.3)	9.00 (228.6)	0.75 (19.1)	3 -	1/2 NPT	21.31 (541.3)	6.25 (158.8)	2.00 (50.8)	6.00 (152.4)
SSB 221	0.31 (7.9)	12 -	21/32 (16.7)	14.50 (368.3)	9.00 (228.6)	0.75 (19.1)	3 -	1/2 NPT	21.31 (541.3)	6.25 (158.8)	2.00 (50.8)	6.00 (152.4)
SSB 321	—	12 -	21/32 (16.7)	14.50 (368.3)	9.00 (228.6)	0.75 (19.1)	3 -	1/2 NPT	21.31 (541.3)	6.25 (158.8)	2.00 (50.8)	6.00 (152.4)
SSB 124H	0.25 (6.4)	12 -	21/32 (16.7)	14.50 (368.3)	9.00 (228.6)	0.75 (19.1)	3 -	1/2 NPT	26.50 (673.1)	8.25 (209.6)	2.00 (50.8)	6.00 (152.4)
SSB 224H	0.25 (6.4)	12 -	21/32 (16.7)	14.50 (368.3)	9.00 (228.6)	0.75 (19.1)	3 -	1/2 NPT	26.50 (673.1)	8.25 (209.6)	2.00 (50.8)	6.00 (152.4)
SSB 324H	—	12 -	21/32 (16.7)	14.50 (368.3)	9.00 (228.6)	0.75 (19.1)	3 -	1/2 NPT	26.50 (673.1)	8.25 (209.6)	2.00 (50.8)	6.00 (152.4)
SSB 127	0.25 (6.4)	16 -	21/32 (16.7)	16.25 (412.8)	9.00 (228.6)	0.75 (19.1)	3 -	1/2 NPT	27.00 (685.8)	8.25 (209.6)	2.50 (63.5)	6.50 (165.1)
SSB 227	0.25 (6.4)	16 -	21/32 (16.7)	16.25 (412.8)	9.00 (228.6)	0.75 (19.1)	3 -	1/2 NPT	27.00 (685.8)	8.25 (209.6)	2.50 (63.5)	6.50 (165.1)
SSB 327	0.25 (6.4)	16 -	21/32 (16.7)	16.25 (412.8)	9.00 (228.6)	0.75 (19.1)	3 -	1/2 NPT	27.00 (685.8)	8.25 (209.6)	2.50 (63.5)	6.50 (165.1)
SSB 130H	0.25 (6.4)	18 -	25/32 (19.8)	19.25 (489)	10.00 (254)	0.75 (19.1)	4 -	1/2 NPT	31.94 (811.3)	8.25 (209.6)	2.50 (63.5)	7.25 (184.2)
SSB 230H	0.25 (6.4)	18 -	25/32 (19.8)	19.25 (489)	10.00 (254)	0.75 (19.1)	4 -	1/2 NPT	31.94 (811.3)	8.25 (209.6)	2.50 (63.5)	7.25 (184.2)
SSB 330H	—	18 -	25/32 (19.8)	19.25 (489)	10.00 (254)	0.75 (19.1)	4 -	1/2 NPT	31.94 (811.3)	8.25 (209.6)	2.50 (63.5)	7.25 (184.2)
SSB 136H	0.25 (6.4)	18 -	25/32 (19.8)	23.63 (600.2)	12.00 (304.8)	0.88 (22.4)	4 -	1/2 NPT	38.25 (971.6)	12.75 (323.9)	6.00 (152.4)	9.00 (228.6)
SSB 236H	0.25 (6.4)	18 -	25/32 (19.8)	23.63 (600.2)	12.00 (304.8)	0.88 (22.4)	4 -	1/2 NPT	38.25 (971.6)	12.75 (323.9)	6.00 (152.4)	9.00 (228.6)
SSB 336H	0.25 (6.4)	18 -	25/32 (19.8) 11/16 (17.5)	23.63 (600.2)	12.00 (304.8)	0.88 (22.4)	4 -	1/2 NPT	38.25 (971.6)	12.75 (323.9)	6.00 (152.4)	9.00 (228.6)

Note: For mounting, use socket head capscrews conforming to the ASTM-574-97a.

(Consult factory for drawing before final layout.)

# Air Tube Disc Clutches and Brakes

## Spring-Set Brakes (Sizes 6, 42-48)

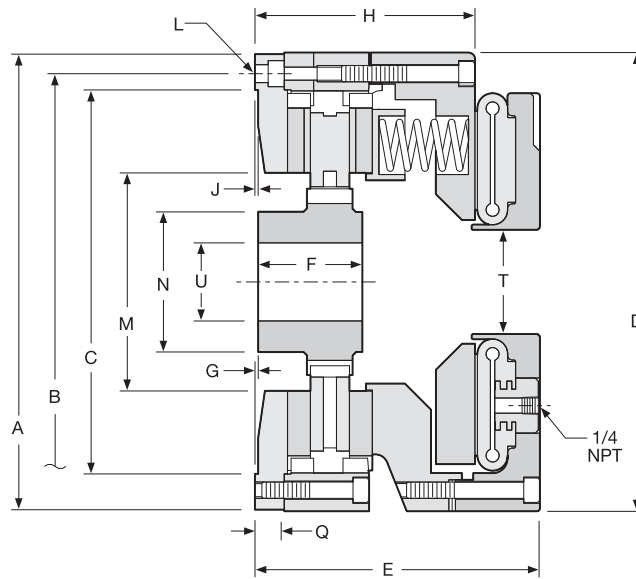

Size 6

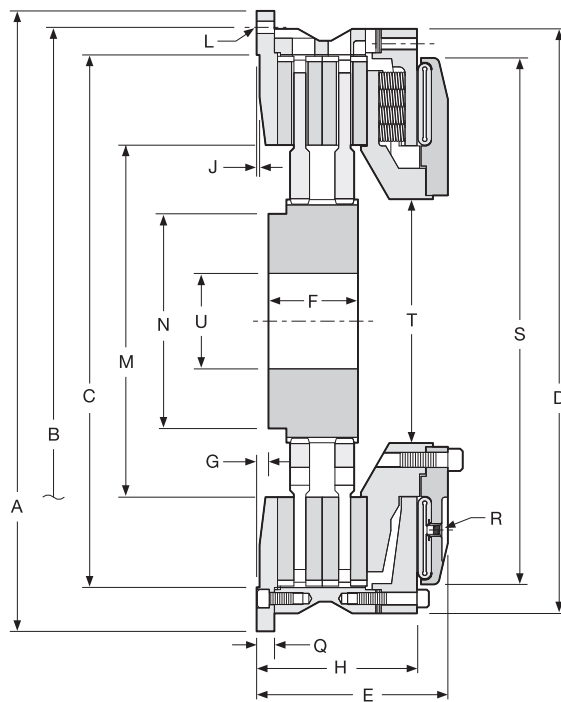

Sizes 42-48

# Air Tube Disc Clutches and Brakes

## Dimensions: inches (mm)

Model Size ATD-	A	B Hole Circle	C Pilot	D	E	F	G	H
SSB 106	8.75	8.000	7.377 / 7.379	8.81	5.47 (138.9)	2.00 (50.8)	0.00 (0.0)	4.22 (107.2)
SSB 206	(222.3)	(203.20)	(187.38 / 187.43)	(223.8)	6.66 (169.2)	3.25 (82.6)	0.06 (1.5)	5.44 (138.2)
SSB 142	52.00	49.250	44.625 / 44.628	49.00	12.28 (311.9)	5.63 (143.0)	1.00 (25.40)	9.69 (246.1)
SSB 242	(1,320.8)	(1,250.95)	(1,133.48 / 1,133.55)	(1,244.6)	16.03 (407.2)	7.50 (190.5)		13.44 (341.4)
SSB 148	61.00	58.000	52.000 / 52.005	56.75	15.00 (381.0)	6.00 (152.4)	0.00 (0.0)	11.19 (284.2)
SSB 248	(1,549.4)	(1,473.20)	(1,320.80 / 1,320.93)	(1,441.5)	19.33 (491.0)	8.75 (222.3)	1.00 (25.4)	15.5 (393.7)
SSB 260 <sup>1</sup>	70.50	66.500	62.750 / 62.760	70.50	22.31 (566.7)	9.38 (238.3)	0.25 (6.40)	17.61 (447.3)
SSB 360 <sup>1</sup>	(1,790.7)	(1,689.10)	(1,593.85 / 1,594.10)	(1,790.7)	26.88 (682.8)	14.13 (358.9)		22.25 (565.2)

## Dimensions: inches (mm)

Model Size ATD-	J	L		M	N	Q	R		S	T	U	
		No. -	Size				No. -	Size			Min.	Max.
SSB 106	0.06	4 -	0.34 (8.6)	4.19	2.69	0.56	2 -	1/4 NPT	—	2.00	0.60	2.00
SSB 206	(1.5)			(106.4)	(68.3)	(14.2)				(50.8)	(15.2)	(50.8)
SSB 142	0.25	24 -	1.06 (26.9)	29.50	18.00	1.50	4 -	1/2 NPT	44.13	20.44	8.00	14.00
SSB 242	(6.4)			(749.3)	(457.2)	(26.9)			(1,102.9)	(519.2)	(203.2)	(355.6)
SSB 148	0.25	24 -	1.06 (26.9)	32.00	25.75	1.50	4 -	1/2 NPT	52.13	19.00	10.00	18.00
SSB 248	(6.4)			(812.8)	(654.1)	(38.1)			(1,324.1)	(482.6)	(254.0)	(457.2)
SSB 260 <sup>1</sup>	0.25	24 -	4.5" NC	36.00	27.00	—	6 -	1/2 NPT	61.50	20.63	11.00	19.00
SSB 360 <sup>1</sup>	(6.4)			(914.4)	(685.8)				(1,562.1)	(524.0)	(279.4)	(482.6)

<sup>1</sup> Less backplate.

**NOTE:** For mounting, use socket head capscrews conforming to the ASTM-574-97a.  
(Consult factory for drawing before final layout.)

# Tension Brakes/Very High Heat Capacity

## AquaMaKKs Water Cooled Clutches and Brakes

AquaMaKKs™ clutches and brakes are pneumatically or hydraulically controlled and water cooled. They consist of a series of alternating friction discs and water jackets. Torque is transmitted by applying axial force from the pneumatic, hydraulic, or spring set actuator. Copper wear plates are used for excellent heat dissipation. AquaMaKKs provides accurate torque control for constant tensioning and are perfectly suited for applications in oil and gas, metal processing and forming, forestry, and marine deck machinery.

### New engineered composite water jacket improves performance

Wichita engineers have utilized the latest cutting edge technologies and state-of-the-art materials to develop a revolutionary new breakthrough in water cooled clutch and brake design... composite water jackets (patent pending).

#### Corrosion resistant, saltwater friendly

Composite material will not corrode, so salt water and water sources with high PH acidic values can be used for cooling without the need to supply fresh water.

Other composite water jacket benefits include:

- Improved channeled water flow - achieved via groove designed and molded into jacket providing enhanced cooling capability
- Easier maintenance, lightweight – smaller sizes do not require a lifting device. Repair/replace jackets in minutes – AquaMaKKs uses fewer copper mounting bolts than competitors
- Water jacket design and material allows for longer life, requiring fewer replacements
- Reduced overall clutch weight – critical for weight restricted applications (eg: truck mounted)
- Lower cost

### AquaMaKKs Design Benefits

- Simplicity of design with fewer parts simplifies installation and maintainability, saving both time and money
- The standard AquaMaKKs design incorporates premium materials and finishes suitable for marine deck environments. No optional salt water corrosion protection is required.
- Shim design makes it easy to maintain and adjust for wear.
- Unique patent pending water jacket design ensures high heat absorption and torque stability, allowing for greater heat dissipation over similar sized competitive units.
- Unique mounting pattern enables direct replacement to Wichita or competitors' units, requiring no design changes for the customer.
- AquaMaKKs is a perfect solution for field retrofits, rebuilds or new OEM applications.

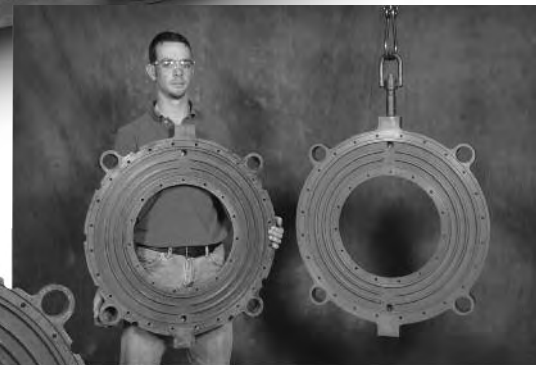

Composite jacket held on left; cast iron jacket suspended from crane on right.

#### 75% Weight Reduction

A new 36" composite water jacket weighs approx. 95 lbs. A 36" cast iron jacket weighs approx. 375 lbs.

The reduced weight is a significant composite jacket benefit, especially where equipment is mounted on a flat bed trailer (eg: in forestry applications such as mobile yarders).



# Tension Brakes/Very High Heat Capacity

## AquaMaKKs Water Cooled Clutches and Brakes



### Oil and Gas

The AquaMakks family is ideally suited for superior water cooled tension control for drawworks applications. It also can be the perfect solution for integration into electronic drilling systems as well as traditional style drawworks control systems.

#### Features that make AquaMaKKs ideal for oil and gas applications:

- Compatible with major electronic drilling systems
- Airtube design has less hysteresis than piston type actuators, making it ideal for automatic drilling systems
- Engineered packaged solutions including shafts, water kits, covers, and deck mounts
- The unit can be easily removed for service if required and/or quickly swapped out for maximum rig availability and rapid serviceability, reducing expensive downtime

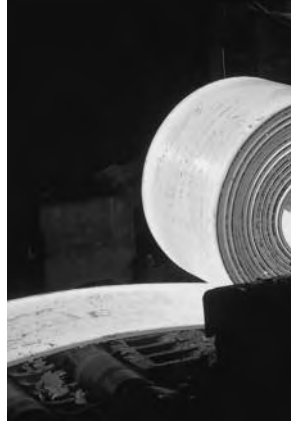

### Metal Processing and Forming

AquaMaKKs clutches and brakes can be used to control tension on the coilers in metal processing plants and to control tension in unwind stands and slitters in metal forming facilities.

#### Features that make AquaMaKKs ideal for metal processing and metal forming applications:

- Compatible with PLC control systems
- Higher thermal capacity than comparable models
- Easy to maintain minimizing downtime
- Open design concept for easy wear inspection
- Safety covers provided for increased operator and plant safety



### Marine Deck Machinery

Positioning and Mooring Winches require high heat dissipation and accurate tension control. That's why AquaMaKKs is ideal for these applications.

#### Features that make AquaMaKKs ideal for marine deck applications:

- The standard AquaMaKKs design incorporates premium materials and finishes suitable for marine deck environments.
- **No optional salt water corrosion protection is required.**
- Compatible with electronic and analog control systems for tension winches
- Long lasting friction material for improved wear life
- Optional designs available for suitability in low temperature environments
- Accessories and packaged engineered solutions available such as deck mounts, manifold kits, water connection kits, covers, and sensor mounting provisions



### Forestry

AquaMaKKs water cooled brakes provide precise tension control on winch drives for mobile forestry equipment, such as yarders.

#### Features that make AquaMaKKs ideal for forestry applications:

- Compatible with tension control systems on yarders
- Open case design enables easy wear inspection and serviceability
- Higher thermal capacity than comparable models
- Lighter weight version available for mobile equipment

# Tension Brakes/Very High Heat Capacity

## AquaMaKKs Water Cooled Clutches and Brakes

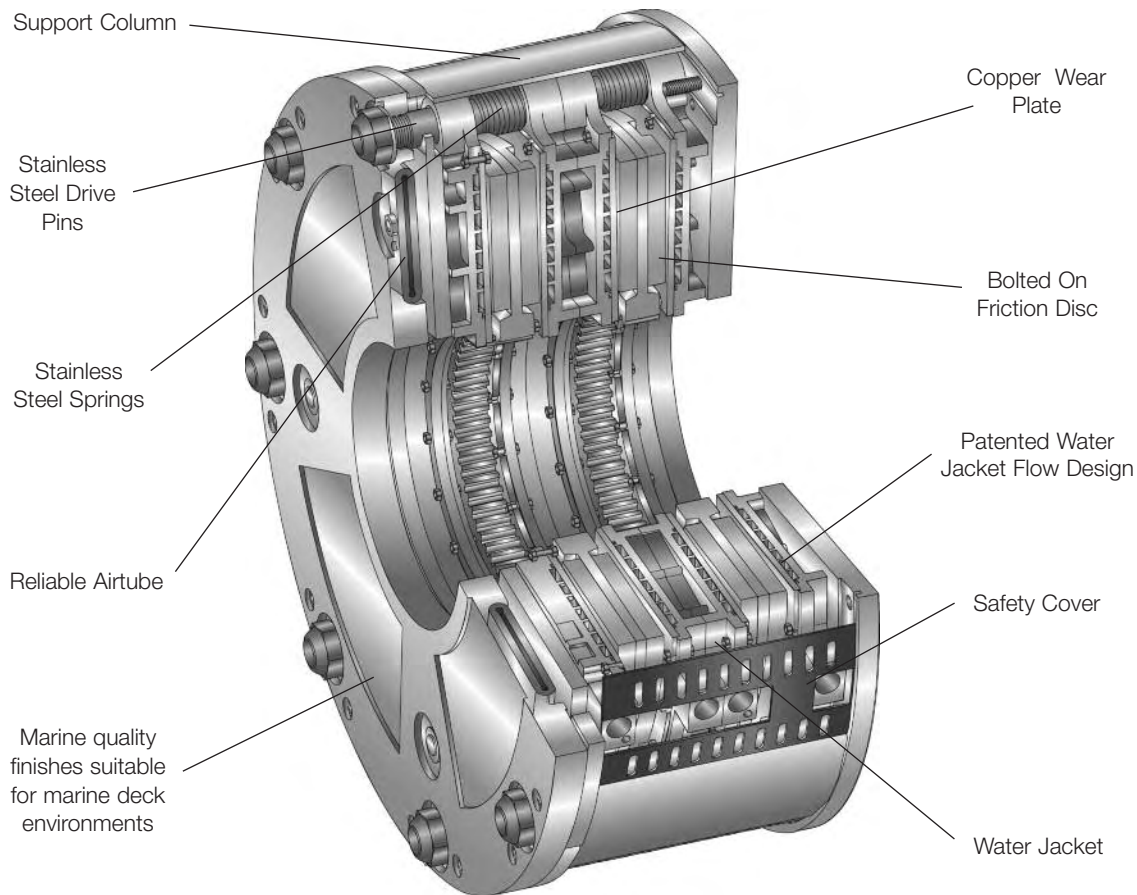

### Features

- The standard AquaMaKKs design incorporates new composite material water jackets which will not corrode.  
**No optional salt water corrosion protection is required.**
- Durable air tube design with high strength reinforced neoprene air-tubes, offering longer service life.
- Water channels for balanced water flow for the highest thermal capacity.
- Long-lasting friction material with minimal wear on mating copper.
- Copper alloy wear plates enable higher heat transfer than any other metals.
- Hub spline provides perfect alignment of rotating discs.
- External air & water connections.
- Release springs ensure complete disengagement.
- Adjustment for wear is easily accomplished by removing shims without any unit disassembly.
- Unique torque pin column arrangement provides structural integrity of case.
- Open case design with covers for safe, simple, visual inspection and easy maintenance.

### Options

- Standard and HICO friction materials available.
- Optional HICO friction material provides up to 50% higher torque.
- Provisions for electronic wear monitoring.
- Customer specific back-plate mounting configurations.
- Custom engineered solutions available for adding accessories such as deck mount assemblies, water kits, shaft assemblies, etc.
- Materials available for operation in low temperature environments.
- Hydraulic piston actuation available.
- Spring Set version with either air or hydraulic release available.

# Tension Brakes/Very High Heat Capacity

## AquaMaKKs Water Cooled Clutches and Brakes

### Horsepower Curves for Models 219, 225, and 236 (Standard Linings)

Contact Wichita Clutch for unique HP curve information

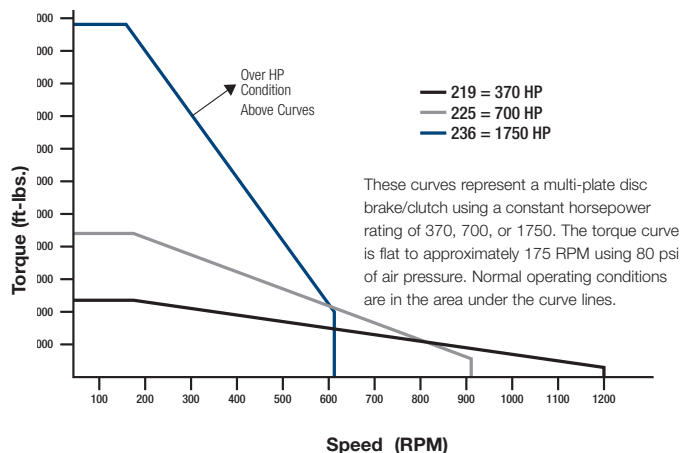

### Component Parts

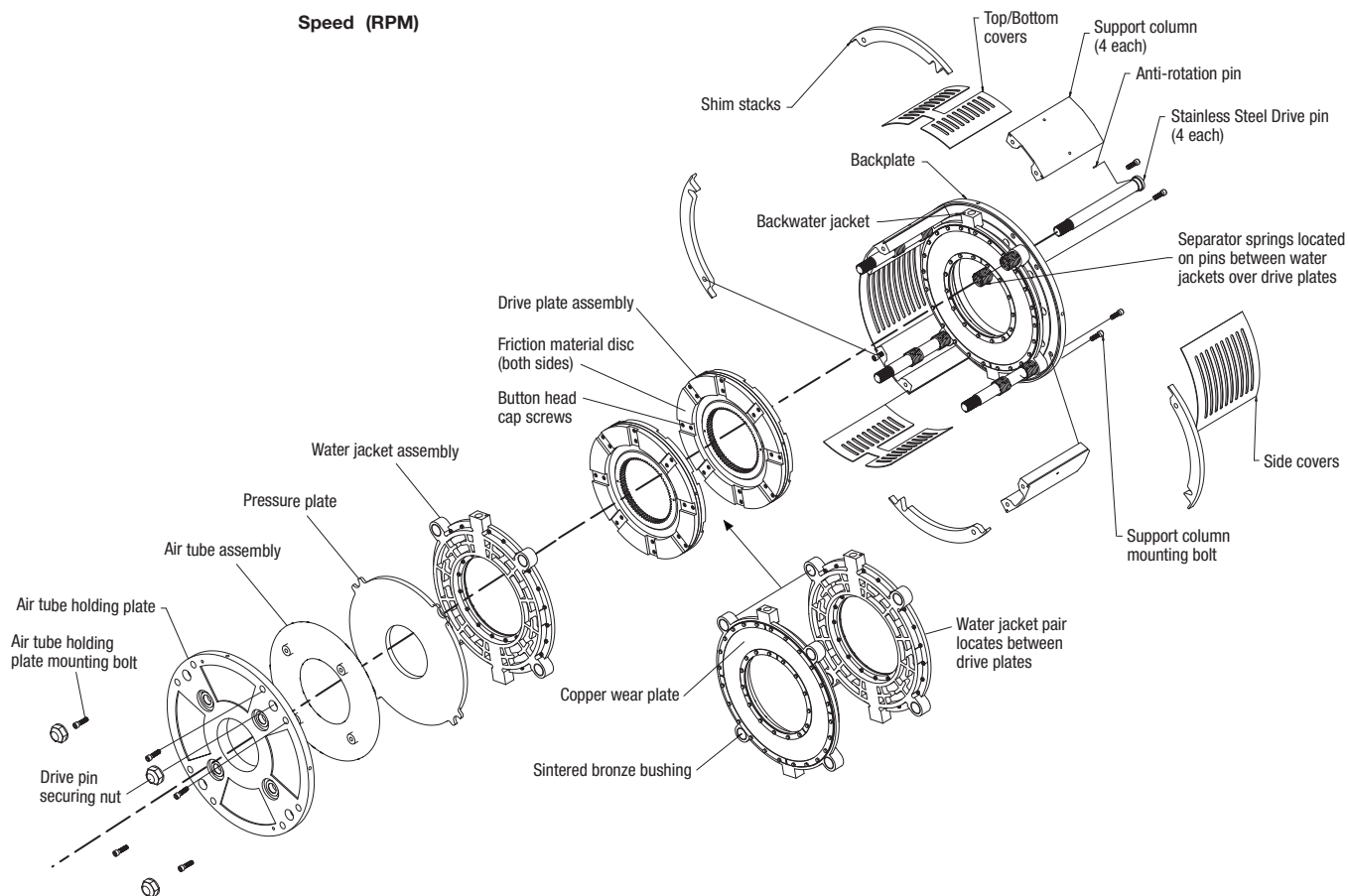

# Tension Brakes/Very High Heat Capacity

## AquaMaKKs Water Cooled Clutches and Brakes

### Ordering Number System

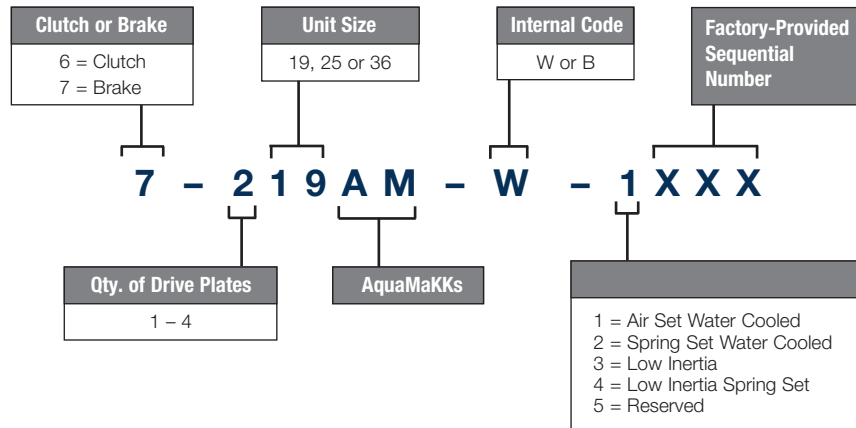

### Dimensions

Model Size ATD-	Assembly Number	(A) Diameter		(B) Width	
		in.	(mm)	in.	(mm)
KKB119AM	7-119AM-W-1000	28.28	718	12.35	317
KKB219AM	7-219AM-W-1000	28.28	718	18.00	457
KKB319AM	7-319AM-W-1000	28.28	718	23.65	601
KKB225AM	7-225AM-W-1000	34.12	867	20.16	512
KKB325AM	7-325AM-W-1000	34.12	867	26.85	682
KKB136AM	7-136AM-W-1000	45.50	1155	11.70	297
KKB236AM	7-236AM-W-1000	45.50	1155	18.80	478
KKB336AM	7-336AM-W-1000	45.50	1155	25.90	658
KKB436AM	7-436AM-W-1000	45.50	1155	33.06	840

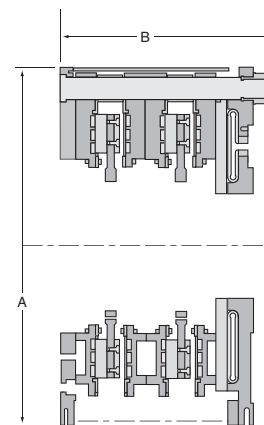

### Specifications

Model Size ATD-	Assembly Number	Dynamic Torque Capacity with Standard Linings (Optional Linings Available)				Heat Capacity		Max Bore Rect. Key in/mm
		lb.in.		Nm		Series Water Hosing	Parallel Water Hosing	
		80 PSI	100 PSI	5.5 BAR	7 BAR	HP/kW	HP/kW	
KKB119AM	7-119AM-W-1000	66,500	83,100	7,500	9,380	93/69	185/138	5.50/140
KKB219AM	7-219AM-W-1000	133,000	166,300	15,000	18,700	185/135	370/276	5.50/140
KKB319AM	7-319AM-W-1000	199,500	249,000	22,500	28,100	278/207	555/414	5.50/140
KKB225AM	7-225AM-W-1000	264,000	330,000	29,800	37,200	350/261	700/522	8.13/207
KKB325AM	7-325AM-W-1000	396,000	495,000	44,700	55,900	600/447	1200/895	8.13/207
KKB136AM	7-136AM-W-1000	322,000	402,000	36,300	45,400	425/317	850/633	8.13/207
KKB236AM	7-236AM-W-1000	644,000	805,000	72,700	90,900	875/652	1750/1304	9.00/229
KKB336AM	7-336AM-W-1000	966,000	1,208,000	109,100	136,400	1275/950	2550/1900	9.00/229
KKB436AM	7-436AM-W-1000	1,288,000	1,611,000	145,600	182,000	1700/1260	3400/2535	9.00/229

### Mounting Hole Pattern

Model	∅A		∅B		∅C		Hole Circle		PLT THK	
	in.	(mm)	in.	(mm)	in.	(mm)	in.	(mm)	in.	(mm)
19	28.28	718	11.00	279	.656	17	25.50	648	1.38	35
25	34.12	867	16.70	424	.656	17	31.00	787	1.38	35
36	45.50	1156	16.75	425	1.06	27	42.72	1085	1.38	35

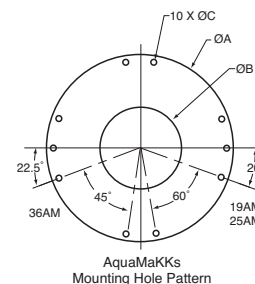

# Tension Brakes/Very High Heat Capacity

## Kopper Kool Brakes

- Copper disc design for high heat dissipation
- Accurate control

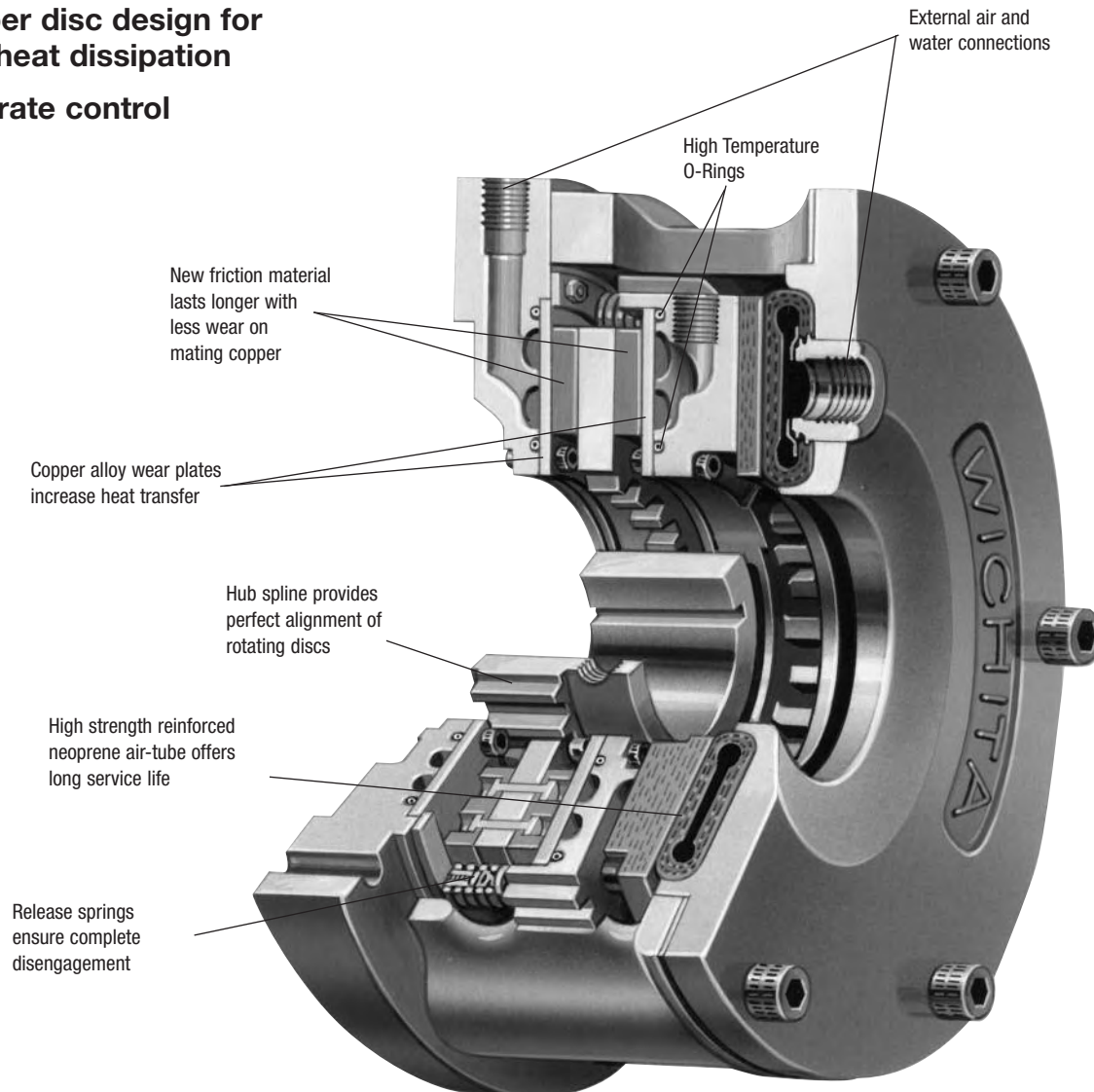

The Wichita Kopper Kool airtube disc Clutches and Brakes are liquid cooled and consist of a series of alternating discs connecting an inner drive member to an outer drive member.

Engagement is achieved by pneumatic expansion of the airtube. This air-operated clutch contains copper discs for excellent heat dissipation and provides an accurately controlled continuous slip action for constant web tensioning. Tension levels are in direct proportion to air pressure applied.

### Design Features

- New friction material lasts longer with less wear on mating copper.
- Copper alloy wear plates increase heat transfer.
- Hub spline provides perfect alignment of rotating discs.
- External air & water connections.
- Release springs ensure complete disengagement.
- High strength reinforced neoprene air-tube offers long service life.
- Optional long stroke air tube available on 18" or 24" size units to increase life and standard maintenance intervals.
- High thermal capacity.

# Tension Brakes/Very High Heat Capacity

## Kopper Kool Brakes

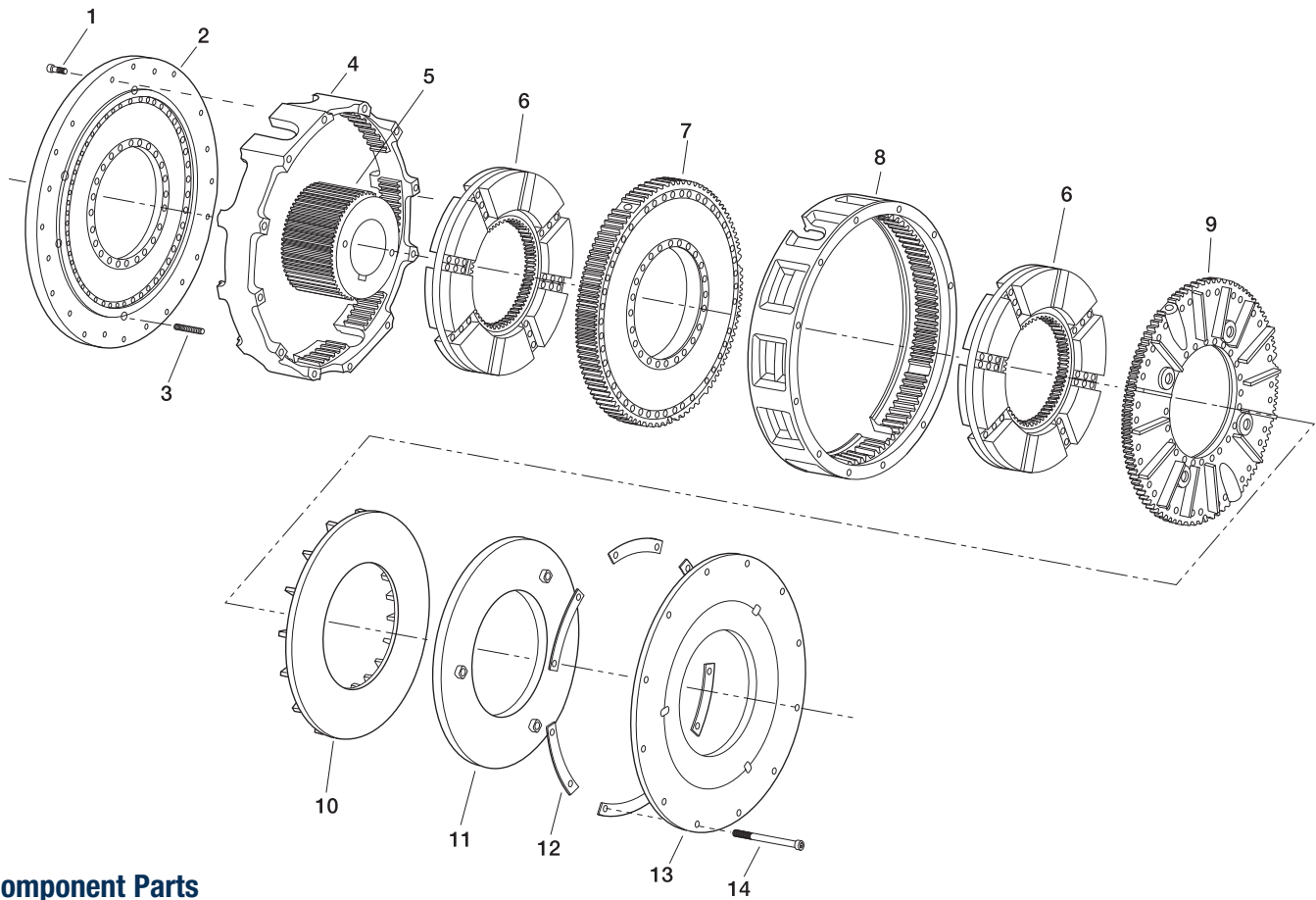

### Component Parts

1. Socket Head Capscrews
2. Backplate Water Jacket Assembly
3. Release Springs
4. Ring (Backplate End)
5. Hub
6. Drive Plate Assembly
7. Center Water Jacket Assembly
8. Ring (Airtube End)
9. Floating Water Jacket Assembly
10. Pressure Plate
11. Airtube
12. Segmented Shims
13. Airtube Holding Plate
14. Socket Head Capscrews

# Tension Brakes/Very High Heat Capacity

## Kopper Kool Brakes

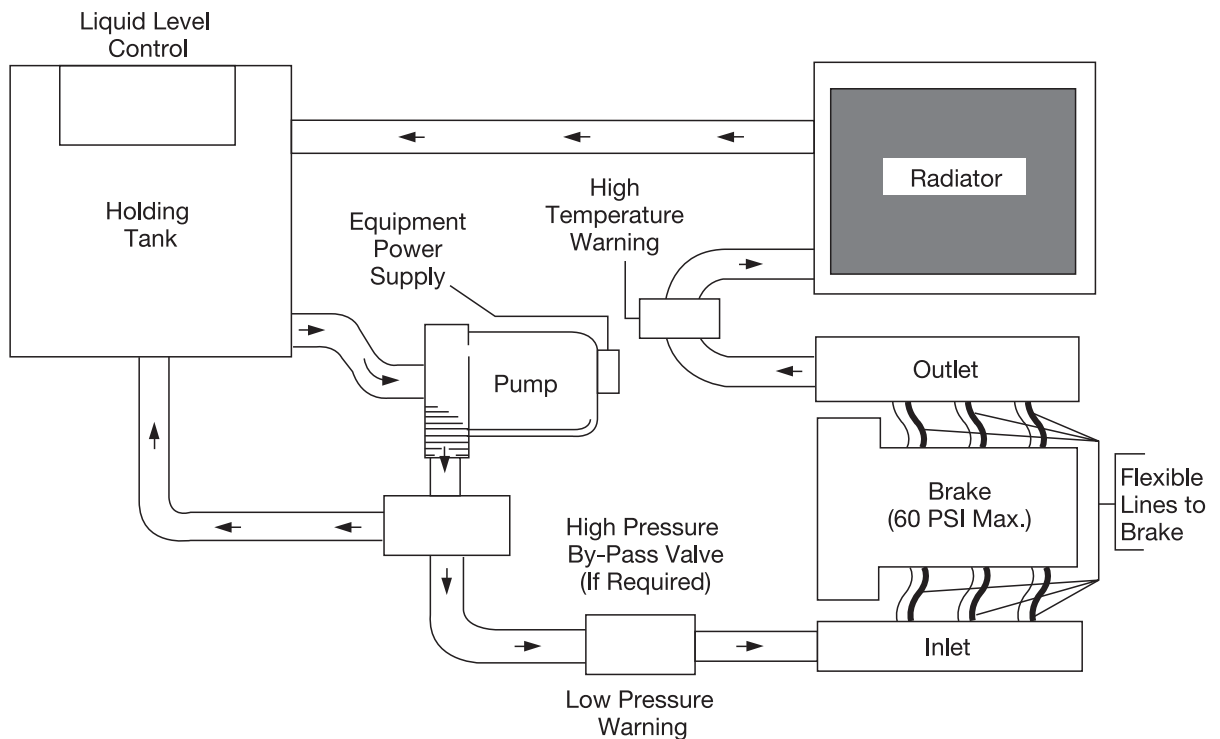

### Principle of Operation

#### Closed Cooling System

As shown here in the closed loop system, flexible water lines should be brought into each jacket at the 6 o'clock position. When the Kopper Kool Unit is used as a clutch, air vent tubes must be installed internally at the factory to insure proper filling of the water jackets. The Kopper Kooled Clutches also require 5 PSI back pressure on the outlet side of the triple passage rotocoupling to insure complete evacuation of air from these jackets during rotation.

Referring to the closed loop cooling system, the equipment should be protected with low water pressure and high temperature warning devices.

For availability information, contact factory.

# Tension Brakes/Very High Heat Capacity

## Kopper Kool Brakes

### Design advantages

- New friction material is longer lasting with less wear on mating copper. Consistent torque response results directly with air pressure applied. Mechanically retained friction pads can be changed in field.
- Copper has a greater heat transfer capacity than any other metal other than precious metals.
- Generated teeth, in addition to providing perfect alignment of rotating members, offer maximum sensitivity of torque to pressure relationship. All factors affecting torque are fully controlled. Tangential cooling grooves insure effective mixing of cooling water for best heat conductivity. Water volume of the jackets insures high water velocity, which reduces sedimentation and chemical formation. Maximum inlet pressure is 60 PSI.
- Close grain alloy iron jackets for coolant assure maximum resistance to corrosion.
- Releasing springs insure complete disengagement.
- By using a triple roto-coupling, the brake can be used as a constant slipping clutch.
- Flexible fiberglass pressure plate assures even distribution of pressure from actuator to braking surfaces, providing maximum contact area on friction surfaces.
- All coolant and air connections are external and easily accessible. Double outlets in center water jackets for multiple plate units 24" and larger.
- Air passages through brake greatly assist in keeping brake cool.
- Actuating member is a reinforced neoprene airtube which has no resistance to movement, resulting in immediate reaction with small pressure changes. Non-corrosion neoprene is unaffected by actuating medium.

### Typical Applications



Wichita Kopper Kool Brakes provide precise tension control on winch drives for mobile equipment.

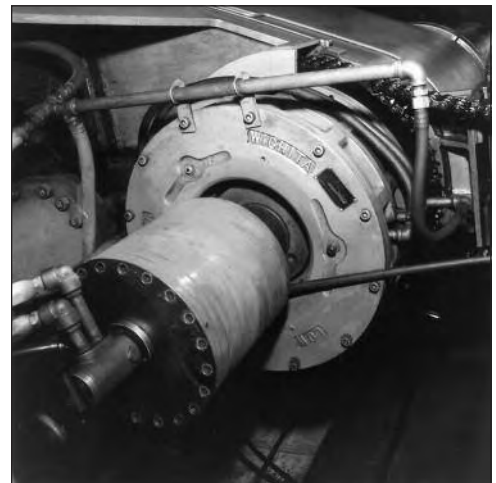

Kopper Kool Brakes dissipate high heat loads in steel uncoiler applications.

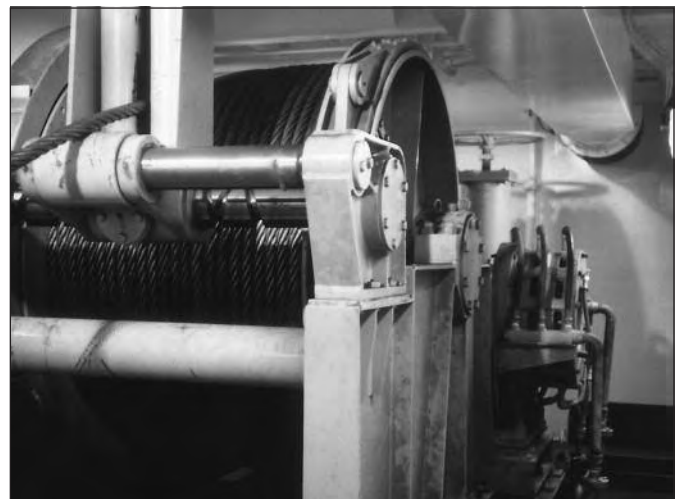

Kopper Kool brakes increase control on marine winches.





# Tension Brakes/Very High Heat Capacity

## Kopper Kool Brakes

### Selecting for an Unwind Application

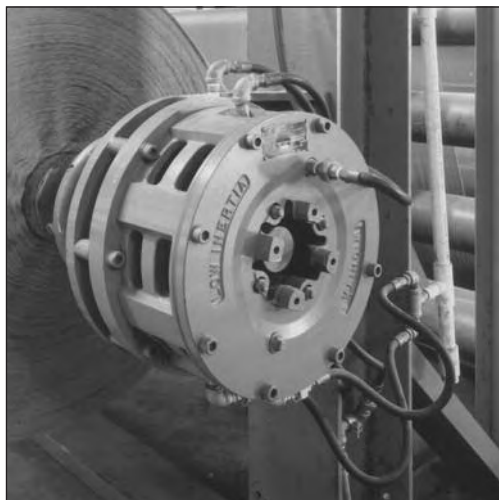

To properly select a tension brake for an unwind application the following information is needed:

Max. Roll Diameter	84 in.
Max. Web Width	120 in.
Max. Web Speed	1500 FPM
Max. Tension	15 PLI
Air Pressure Available	100 PSI
Min. Roll Diameter	12 in.
Min. Web Width	84 in.
Min. Web Speed	750 FPM
Min. Tension	10 PLI
Shaft Size	5.00

### Calculations

Using the calculations below, consult Kopper Kool Brake Specifications Chart, page 80.

The brake selected for this application is a 218 Kopper Kool, with 5.5 inch bore.

$$\begin{aligned} \text{Max. Tension} &= \text{Max. PLI} \times \text{Max. Web Width} \\ &= 15 \times 120 = 1,800 \text{ lbs.} \end{aligned}$$

$$\begin{aligned} \text{Max. Torque} &= \frac{\text{Max. Tension} \times \text{Max. Roll Dia.}}{2} \\ &= 1800 \times 84/2 = 75,600 \text{ lb.in.} \end{aligned}$$

$$\begin{aligned} \text{Max. RPM} &= \frac{\text{Max. Web Speed} \times 3.82}{\text{Min. Roll Dia.}} \\ &= 1,500 \times 3.82/12 = 478 \text{ RPM} \end{aligned}$$

$$\begin{aligned} \text{Heat HP} &= \frac{\text{Max. Tension} \times \text{Max. Web Speed}}{33,000} \\ &= \frac{1,800 \times 1,500}{33,000} = 82 \text{ Heat HP} \end{aligned}$$

$$\begin{aligned} \text{Min. Tension} &= \text{Min. PLI} \times \text{Min. Web Width} \\ &= 10 \times 84 = 840 \text{ lbs.} \end{aligned}$$

$$\begin{aligned} \text{Min. Torque} &= \frac{\text{Min. Tension} \times \text{Min. Roll Dia.}}{2} \\ &= 840 \times 12/2 = 5,040 \text{ lb.in.} \end{aligned}$$

$$\begin{aligned} \text{Min. RPM} &= \frac{\text{Min. Web Speed} \times 3.82}{\text{Max. Roll Dia.}} \\ &= 750 \times 3.82/84 = 34 \text{ RPM} \end{aligned}$$

### How to select

1. Select a brake with equal to or greater thermal capacity. The ATD-214 has 150 THP @ 15 GPM. The requirement is 82 THP.
2. Check torque capacity vs. required. The ATD-214 has 42,000 lb.in. @ 100 PSI. The requirement is 75,600 lb.in. Therefore, an ATD-214 Brake will not produce enough torque for this application. An ATD-218 Brake would be the best choice.
3. Check Maximum Bore. The requirement is 5.00 inches. The ATD-218 maximum bore is 5.5 inches.
4. Check Maximum RPM. The requirement is 478 RPM. The maximum RPM for the ATD-218 is 1,300 RPM.

$$\begin{aligned} \text{Max. Air Pressure Required} &= \frac{\text{Max. Torque} \times 100 \text{ PSI}}{\text{Catalog Torque Rating}} \\ &= \frac{75,600 \times 100}{94,000} = 80 \text{ PSI} \end{aligned}$$

$$\begin{aligned} \text{Min. Air Pressure Required} &= \frac{\text{Min. Torque} \times 100 \text{ PSI}}{\text{Catalog Torque Rating}} \\ &= \frac{5,040 \times 100}{94,000} = 5 \text{ PSI} \end{aligned}$$

# Tension Brakes/Very High Heat Capacity

## Kopper Kool Brakes

### Specifications

Model Size ATD-	Assembly Number	Dynamic Torque Capacity*				Heat Capacity		Max Bore Rect. Key	
		lb.in.		Nm		Series Water Hosing	Parallel Water Hosing	in.	(mm)
		80 PSI	100 PSI	5.5 BAR	7 BAR	HP/kW	HP/kW		
KKB 106	7-306-110-200-0	2,720	3,400	307	384	10 / 7.5	15 / 11	1.75	(44)
KKB 206	7-306-210-200-0	5,440	6,800	614	768	20 / 15	30 / 22		
KKB 108	7-308-110-100-0	4,320	5,400	479	610	21 / 16	32 / 24		
KKB 208	7-308-210-100-0	8,640	10,800	959	1,220	42 / 31	64 / 48	2.25	(57)
KKB 308	7-308-310-101-0	12,960	16,200	1,438	1,830	63 / 47	96 / 72		
KKB 111	7-311-110-106-0	9,600	12,000	1,065	1,356	35 / 26	53 / 40	3.00	(76)
KKB 211	7-311-210-107-0	19,200	24,000	2,131	2,712	70 / 52	105 / 78		
KKB 311	7-311-310-100-0	28,800	36,000	3,196	4,067	105 / 78	158 / 118		
KKB 114	7-314-110-115-0	16,800	21,000	1,864	2,373	50 / 37	75 / 56	4.38	(111)
KKB 214	7-314-210-111-0	33,600	42,000	3,728	4,745	100 / 75	150 / 112		
KKB 314	7-314-310-103-0	50,400	63,000	5,593	7,118	150 / 112	225 / 168		
KKB 116	7-316-110-107-0	25,600	32,000	2,841	3,615	65 / 48	98 / 73	4.75	(121)
KKB 216	7-316-210-108-0	51,200	64,000	5,681	7,231	130 / 97	195 / 145		
KKB 118	7-318-110-100-0	37,600	47,000	4,172	5,310	80 / 60	120 / 89	5.50	(140)
KKB 218	7-318-210-100-0	75,200	94,000	8,344	10,620	160 / 119	240 / 179		
KKB 318	7-318-310-101-0	112,800	141,000	12,517	15,930	240 / 179	360 / 268		
KKB 119	7-319-110-104-0	52,000	65,000	5,770	7,344	—	160 / 119	5.50	(140)
KKB 219	7-319-210-111-0	104,000	130,000	11,540	14,688	—	320 / 239		
KKB 121	7-321-110-100-0	49,600	62,000	5,504	7,005	100 / 75	150 / 112	6.50	(165)
KKB 221	7-321-210-102-0	99,200	124,000	11,008	14,010	200 / 149	300 / 224		
KKB 321	7-321-310-100-0	148,800	186,000	16,511	21,015	300 / 224	450 / 336		
KKB 124H	7-325-110-100-0	100,800	126,000	11,185	14,236	190 / 142	285 / 213	7.63	(194)
KKB 224H	7-325-210-101-0	201,600	252,000	22,370	28,471	380 / 283	570 / 425		
KKB 324H	7-325-310-101-0	302,400	378,000	33,556	42,707	570 / 425	855 / 638		
KKB 125	7-326-100-100-0 <sup>1</sup>	122,920	153,650	13,880	17,360	—	350/261	8.13	(207)
KKB 225	7-326-200-100-0 <sup>1</sup>	245,840	307,300	27,760	34,719	—	700 / 522		
KKB 325	7-326-300-101-0 <sup>1</sup>	368,760	460,950	41,640	52,079	—	1050/783		
KKB 127	7-327-110-100-0	120,000	150,000	13,316	16,947	175 / 130	263 / 196	8.00	(203)
KKB 227	7-327-210-100-0	240,000	300,000	26,631	33,894	350 / 261	233 / 174		
KKB 130	7-330-110-300-0	160,000	200,000	17,754	22,596	230 / 172	345 / 257	9.00	(229)
KKB 230	7-330-210-301-0	320,000	400,000	35,508	45,193	460 / 343	690 / 515		
KKB 330	7-330-310-300-0	480,000	600,000	53,263	67,789	690 / 515	1,035 / 772		
KKB 136H	7-337-110-300-0	320,000	400,000	36,154	45,193	500 / 373	750 / 559	9.00	(229)
KKB 236H	7-337-210-300-0	640,000	800,000	72,308	90,385	1,000 / 746	1,500 / 1,119		
KKB 336H	7-337-310-300-0	960,000	1,200,000	108,462	135,578	1,500 / 1,119	2,250 / 1,678		
KKB 436H	7-337-410-102-0 <sup>2</sup>	1,250,000	1,600,000	141,227	180,771	2,000 / 1,491	3,000 / 2,237	12.50	(317)
KKB 346 <sup>4</sup>	7-346-310-100-0 <sup>3</sup>	2,104,000	2,630,000	233,468	297,142	2,200 / 1,641	3,300 / 2,461		

\* Static torque will vary with temperature. Maximum air pressure is 100 PSI / 7 BAR. Minimum recommended air pressure is 3 PSI.

**Note:** Maximum water jacket inlet pressure is 60 PSI.

Brakes with as great as 50% higher torque capacity is available upon request.

<sup>1</sup> Current design is with enhanced linings. A unit with regular linings is available upon request.

<sup>2</sup> Current design is with the Marine Corrosion package. A Non-Marine unit is available upon request.

<sup>3</sup> Current design is for intermittent duty applications. Such as, anchor, mooring, take-up and traction type winch applications.

<sup>4</sup> For information purposes, not for new applications

# Tension Brakes/Very High Heat Capacity

## Kopper Kool Brakes Specifications

Model Size ATD-	Recom- mended Clearance in.(mm)	Max. Speed RPM	Parallel Water Flow % Ethylene Glycol GPM (LPM)			Total Brake Wt.		Hub & Drive Plate Wt.			
			0%	30%	50%	lb.	(kg)	lb.	(kg)	WR <sup>2</sup> / J=mr <sup>2</sup>	
						lb.ft. <sup>2</sup>	(kgm <sup>2</sup> )				
KKB 106	1/16-3/32 (1.5-2)	3,800	1.5 (6)	2.0 (7.4)	2.3 (8.5)	45	(20.4)	5.5	(2.5)	0.14	(0.01)
KKB 206			3 (11)	3.9 (14.8)	4.5 (17)	71	(32.2)	11.7	(5.3)	0.28	(0.01)
KKB 108	1/16-3/32 (1.5-2)	2,860	3.2 (12)	4.1 (1.6)	5 (19)	68	(30.8)	11	(5.0)	0.6	(0.03)
KKB 208	3/32-5/32 (2-4)		6.4 (24)	8.2 (32)	10 (38)	116	(52.6)	25	(11.1)	1.3	(0.05)
KKB 308	1/8-3/16 (3-5)	2,100	9.6 (36)	12.3 (48)	15 (57)	164	(74.4)	38	(17.2)	2.0	(0.08)
KKB 111	1/16-3/32 (1.5-2)		5.3 (20)	6.9 (26)	8 (30)	146	(66.2)	24	(10.9)	2	(0.08)
KKB 211	3/32-5/32 (2-4)	1,600	10.5 (40)	13.7 (52)	15.8 (60)	230	(104.3)	54	(24.5)	4	(0.17)
KKB 311	1/8-3/16 (3-5)		15.8 (60)	20.5 (78)	20.5 (78)	314	(142.4)	84	(38.1)	6.0	(0.25)
KKB 114	1/16-3/32 (1.5-2)	1,400	7.5 (28)	9.8 (37)	12 (45)	221	(100.2)	40	(18)	5	(0.21)
KKB 214	3/32-5/32 (2-4)		15 (57)	20 (74)	24 (90)	345	(156.5)	80	(36)	11	(0.44)
KKB 314	1/8-3/16 (3-5)	1,300	22.5 (84)	29 (111)	36 (135)	470	(213.2)	120	(54)	16	(0.67)
KKB 116	1/16-3/32 (1.5-2)		9.8 (37)	12.7 (48)	15 (56)	298	(135)	75	(34)	12	(0.51)
KKB 216	3/32-5/32 (2-4)	1,200	19.5 (74)	25.4 (96)	29 (111)	650	(295)	143	(65)	25	(1.07)
KKB 118	1/16-1/8 (1.5-2)		12 (45)	16 (60)	19 (72)	415	(188)	88	(39.9)	18	(0.76)
KKB 218	3/32-5/32 (2-4)	1,100	24 (90)	32 (120)	38 (144)	565	(256)	176	(79.8)	36	(1.52)
KKB 318	1/8-3/16 (3-5)		36 (135)	48 (180)	57 (216)	715	(324)	264	(119.7)	54	(2.28)
KKB 119	3/32-5/32 (2-4)	960	16 (61)	21 (79)	24 (91)	337	(153)	84	(38)	12.5	(0.53)
KKB 219	3/32-5/32 (2-4)		32 (121)	42 (158)	48 (182)	464	(210)	144	(65)	21.6	(0.91)
KKB 121	3/32-5/32 (2-4)	850	15 (57)	20 (74)	24 (90)	600	(272)	138	(63)	34	(1.43)
KKB 221	1/8-3/16 (3-5)		30 (114)	39 (148)	45 (170)	870	(395)	226	(103)	64	(2.70)
KKB 321	5/32-7/32 (4-6)	760	45 (170)	59 (221)	68 (255)	1,075	(488)	301	(137)	97	(4.09)
KKB 124H	3/32-5/32 (2-4)		29 (106)	38 (144)	45 (170)	935	(424)	240	(109)	110	(4.64)
KKB 224H	1/8-3/16 (3-5)	640	58 (212)	76 (288)	90 (340)	1,500	(680)	410	(186)	210	(8.85)
KKB 324H	5/32-7/32 (4-6)		87 (318)	114 (432)	135 (510)	2,065	(937)	580	(263)	310	(13.07)
KKB 125	3/32-5/32 (2-4)	935	35 (132)	45 (170)	54 (204)	886	(402)	—	—	—	—
KKB 225	1/8-3/16 (3-5)		70 (264)	90 (340)	108 (408)	1,421	(645)	—	—	—	—
KKB 325	5/32-7/32 (4-6)	850	105 (396)	135 (510)	162 (611)	1,956	(887)	—	—	—	—
KKB 127	3/32-5/32 (2-4)		27 (102)	35 (133)	41 (153)	981	(445)	227	(103)	92	(3.87)
KKB 227	1/8-3/16 (3-5)	760	54 (204)	70 (266)	81 (307)	1,320	(599)	426	(193)	179	(7.55)
KKB 130	3/32-5/32 (2-4)		35 (132)	45 (170)	54 (204)	1,134	(514)	263	(119)	139	(5.86)
KKB 230	1/8-3/16 (3-5)	480	70 (264)	90 (340)	108 (408)	1,850	(839)	530	(240)	275	(11.59)
KKB 330	5/32-7/32 (4-6)		105 (396)	135 (510)	162 (612)	2,565	(1,163)	795	(361)	410	(17.28)
KKB 136H	3/32-5/32 (2-4)	640	75 (284)	98 (369)	120 (454)	2,550	(1,157)	535	(243)	410	(17.28)
KKB 236H	1/8-3/16 (3-5)		150 (568)	195 (738)	240 (908)	4,111	(1,865)	925	(420)	790	(33.31)
KKB 336H	5/32-7/32 (4-6)	480	225 (852)	294 (1,107)	360 (1,362)	5,595	(2,538)	1,685	(764)	1,621	(68.3)
KKB 436H	3/16-1/4 (5-7)		300 (1,136)	390 (1,476)	450 (1,703)	6,772	(3,072)	2,198	(997)	2,079	(87.6)
KKB 346	3/16-5/16 (5-8)	480	330 (1,249)	429 (1,624)	495 (1,874)	10,800	(4,899)	3,040	(1,379)	4,981	(210)

C

# Tension Brakes/Very High Heat Capacity

## Kopper Kool Brakes

### Specifications

Model Size	Pressure Drop Parallel Flow w/ % Ethylene Glycol PSI / (BAR)			Pressure Drop Series Flow w/ % Ethylene Glycol PSI / (BAR)			Maximum Lining Wear		Water Volume in. <sup>3</sup> / (dm <sup>3</sup> )
	0%	30%	50%	0%	30%	50%	in./(cm)	in. <sup>3</sup> /(dm <sup>3</sup> )	
ATD-									
KKB 108				4 (0.14)	9 (0.62)	9 (0.62)			8 (0.13)
KKB 208	0.9 (0.06)	1.6 (0.11)	2.3 (0.16)	11(0.76)	25 (1.72)	32 (2.21)	0.4 (1.0)	10 (0.2)	16 (0.26)
KKB 308				15(1.03)	34 (2.34)	41 (2.83)			24 (0.4)
KKB 114				4 (0.14)	8 (0.55)	12 (0.83)			20 (0.33)
KKB 214	1.2 (0.08)	1.6 (0.11)	1.8 (0.12)	24(1.66)	40 (2.76)	52 (3.59)	0.5 (1.3)	60 (1.0)	40 (0.65)
KKB 314				28 (1.93)	48 (3.31)	—			60 (1)
KKB 118				7 (0.48)	13 (0.9)	20 (1.38)			48 (0.8)
KKB 218	1.7 (0.12)	2.4 (0.17)	2.8 (0.19)	52 (3.59)	—	—	0.6 (1.5)	75 (1.2)	96 (1.5)
KKB 318				—	—	—			144 (2.35)
KKB 124H				7 (0.48)	11 (0.76)	14 (0.97)			110 (1.8)
KKB 224H	1.9 (0.13)	2.4 (0.17)	3.1 (0.21)	23 (1.59)	35 (2.41)	48 (3.31)	0.8 (2.0)	200 (3.3)	220 (3.6)
KKB 324H				30 (2.07)	46 (3.17)	—			330 (1.8)
KKB 130				9 (0.62)	14 (0.97)	21 (1.45)			190 (3.1)
KKB 230	2.1 (0.14)	2.4 (0.17)	3.1 (0.21)	31 (2.14)	48 (3.31)	—	0.8 (2.0)	240(3.9)	380 (6.2)
KKB 330				40 (2.76)	—	—			570 (9.3)
KKB 136H				14 (0.97)	24 (1.66)	—			285 (4.7)
KKB 236H	4.0 (0.28)	5.3 (0.37)	7.2 (0.50)	60 (4.14)	—	—	0.8 (2.0)	500 (8.2)	570 (9.3)
KKB 336H				—	—	—			855 (14)

### PSI Pressure Curves

The cooling water requirements are listed in the specification table. The pressure drop across the brakes is given for both parallel and series flow. This table also indicates the increased flow requirement when using a mixture of ethylene glycol as an antifreeze or for corrosion protection.

The normal water requirement for Kopper Kool brakes and clutches is one gallon of water for each 10 horsepower or one liter of water for each 2 kilowatts being dissipated. This amount of flow will give a temperature rise through the brake of 50° F (28° C). The outlet water temperature should not exceed 170° F (77° C).

The curves shown in Figures 1 and 3 indicate the pressure through the listed units for both parallel and series flow. Also shown in Figure 2 is the flow through the optional triple passage roto-couplings for Kopper Kool clutches. The data in Figures 1, 2, and 3 will aid in estimating pressure drops for different flow requirements.

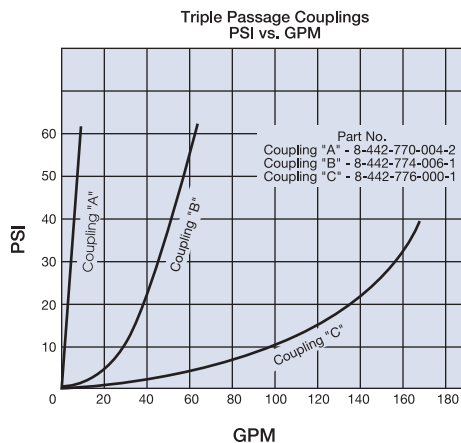

Figure 2

From Figure 2 for 20 GPM PSI drop is 5. The pressure drop would be 6.2 PSI across the inlet and outlet of coupling "B" for this application.

Horsepower ratings as shown are for continuous slip. The ratings can be increased for intermittent service. Please consult the factory for such applications.

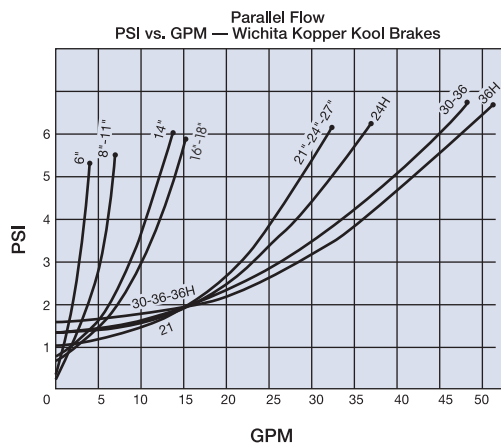

Figure 1

An example of the use of these flow tables is: An ATD-224H clutch is selected for 200 horsepower @ 190 RPM.

The torque requirement is 66,316 lb.in.

Water flow required = 20 GPM  
(4 inlets - 4 outlets @ 5 GPM ea.)

From Figure 1 for 20 GPM  
(24H Curve at 5 GPM) PSI drop is 1.2.

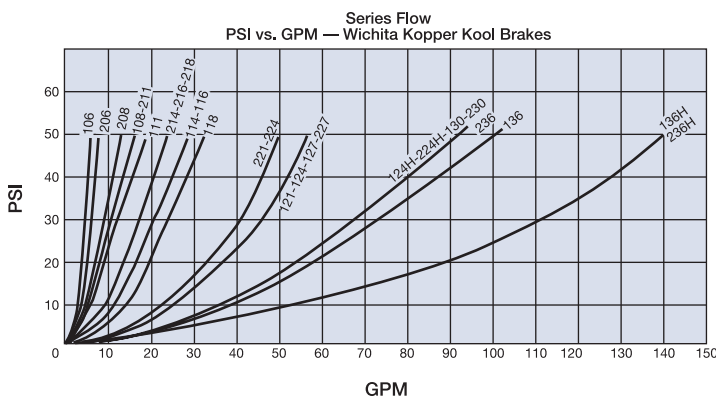
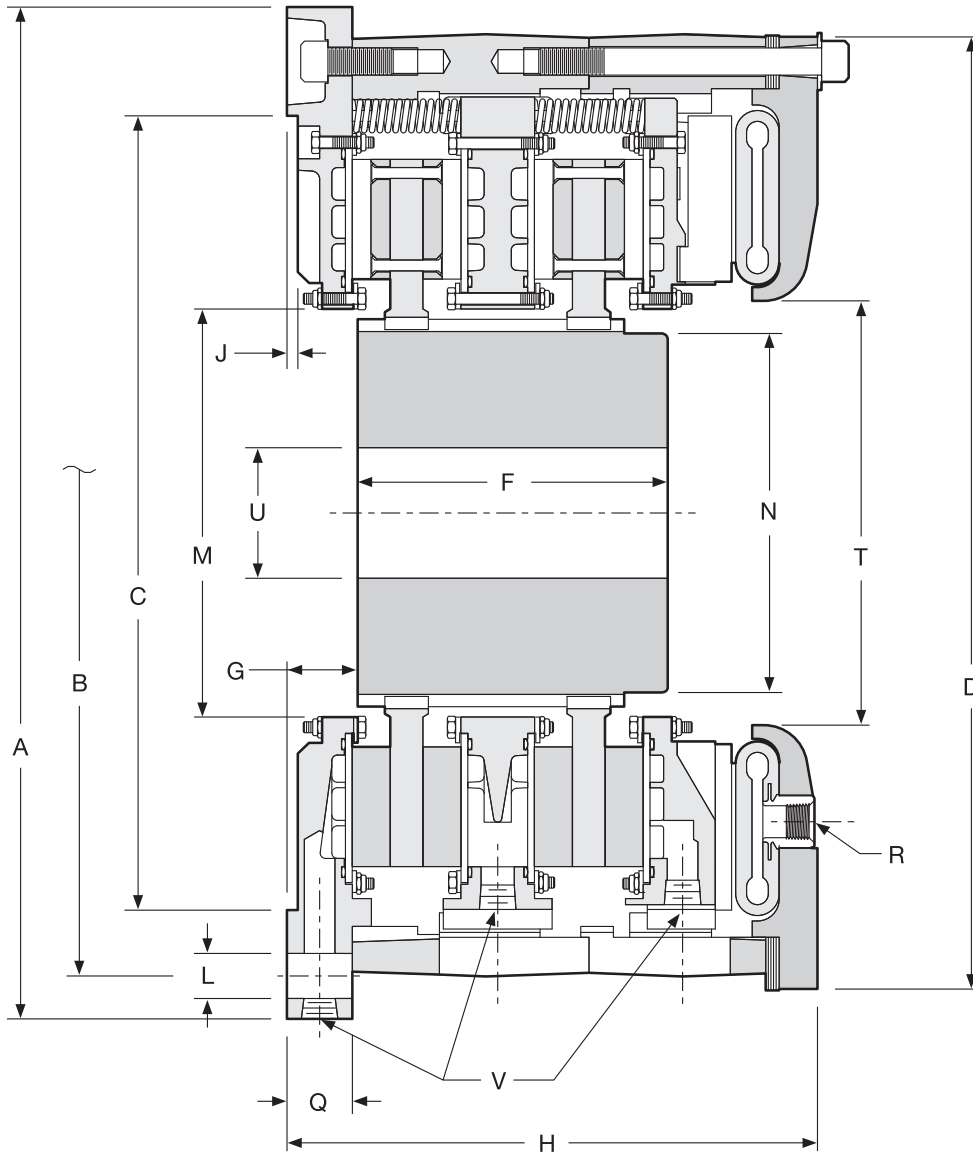

Figure 3

# Tension Brakes/High Heat Capacity

## Kopper Kool Brakes



For mounting hole pattern, see following pages.  
For sizes 19 and 25 see page 88.

# Tension Brakes/High Heat Capacity

## Kopper Kool Brakes

### Dimensions: inches (mm)

Model Size ATD-	A Pilot	B Hole Circle	C Pilot	D	F	G	H	J
KKB 106	8.751 / 8.753	8.000	7.377 / 7.379	8.81	2.00 (50.8)		5.25 (133.4)	
KKB 206	(222.28 / 222.33)	(203.20)	(187.38 / 187.43)	(223.8)	4.63 (117.6)	.75(19.1)	7.63 (193.8)	0.13 (3.3)
KKB 108					2.00 (50.8)		5.68 (144.3)	
KKB 208	12.125 / 12.128	11.125	8.375 / 8.378	11.75	4.25 (108)	1.13(28.7)	8.43 (214.1)	0.25 (6.4)
KKB 308	(307.98 / 308.05)	(282.58)	(212.73 / 212.80)	(288.5)	7.00 (177.8)		11.12 (282.4)	
KKB 111					2.88 (73.2)		6.32 (160.5)	
KKB 211	15.997 / 16.000	14.75	11.375 / 11.378	14.75	6.13 (155.7)	.75 (19.1)	9.56 (242.8)	0.25(6.4)
KKB 311	(406.32 / 406.40)	(374.65)	(288.93 / 289.00)	(374.7)	9.12 (231.6)		12.81 (325.4)	
KKB 114					3.25 (82.6)	1.06(26.9)	7.00 (177.8)	
KKB 214	18.747 / 18.750	17.500	14.375 / 14.378	17.50	5.88 (149.4)	1.69 (42.9)	10.57 (268.5)	0.25(6.4)
KKB 314	(476.17 / 476.25)	(444.50)	(365.13 / 365.20)	(444.5)	9.13 (231.9)	1.69 (42.9)	14.13 (358.9)	
KKB 116					4.00 (101.6)	1.25(31.8)	7.56 (192.0)	
KKB 216	21.245 / 21.248	20.000	16.250 / 16.253	20.00	7.00 (177.8)		11.50 (292.1)	0.25(6.4)
KKB 316	(539.62 / 539.70)	(508.00)	(412.75 / 412.83)	(508.0)				
KKB 118					3.63 (92.1.2)	1.06 (26.9)	8.00 (203.2)	
KKB 218	23.247 / 23.250	22.000	18.250 / 18.253	21.88	7.13 (181.1)	1.63 (41.4)	12.19 (309.6)	0.25(6.4)
KKB 318	(590.47 / 590.55)	(558.80)	(463.55 / 463.63)	(555.8)	10.75 (273.1)	1.63 (41.4)	16.38 (416.1)	
KKB 121					5.50 (139.7)	1.25 (31.8)	8.38 (212.9)	
KKB 221	26.977 / 27.000	25.500	21.375 / 21.378	24.88	7.94 (201.7)	1.50 (38.1)	15.81 (401.6)	0.25(6.4)
KKB 321	(685.22 / 685.80)	(647.70)	(542.93 / 543.00)	(632.0)	12.44 (316.0)	1.25 (31.8)	17.19 (436.6)	
KKB 124H					5.00 (127.0)		9.79 (248.7)	
KKB 224H	29.997 / 30.000	28.750	24.375 / 24.378	31.00	8.63 (219.2)	1.38 (35.1)	14.68 (372.9)	0.25 (6.4)
KKB 324H	(761.9 / 762.0)	(730.25)	(619.13 / 619.20)	(787.4)	13.63 (346.2)		19.56 (496.8)	

### Dimensions: inches (mm)

Model Size ATD-	L		M	N	Q	R		T	U		V <sup>1</sup> - Inlets
	No. -	Size				No. -	Size		Min.	Max.	No. -
KKB 106			2.94	2.43	0.38			2.00	0.60	1.75	2 - 1/4 NPT
KKB 206	4 -	0.34 (8.6)	(74.7)	(61.7)	(9.7)	2 -	1/2 NPT	(50.8)	(15.2)	(44.5)	3 - 1/4 NPT
KKB 108											2 - 3/8 NPT
KKB 208	4 -	17/32 (13.5)	(111.3)	(88.9)	(35.1)	2 -	1/2 NPT	(95.3)	1.00	2.25	3 - 3/8 NPT
KKB 308									(25.4)	(57.2)	4 - 3/8 NPT
KKB 111											2 - 1/2 NPT
KKB 211	4 -	21/32 (16.7)	(136.7)	(117.6)	(28.7)	2 -	1/2 NPT	(133.4)	1.00	3.00	3 - 1/2 NPT
KKB 311									(25.4)	(76.2)	4 - 1/2 NPT
KKB 114											2 - 1/2 NPT
KKB 214	6 -	21/32 (16.7)	(187.5)	(165.1)	(38.1)	2 -	1/2 NPT	(177.8)	1.38	4.38	3 - 1/2 NPT
KKB 314									(35.1)	(111.3)	4 - 1/2 NPT
KKB 116											2 - 1/2 NPT
KKB 216	10 -	21/32 (16.7)	(218.9)	(190.5)	(38.1)	2 -	1/2 NPT	(212.9)	1.38	4.75	3 - 1/2 NPT
KKB 118											2 - 1/2 NPT
KKB 218	10 -	21/32 (16.7)	(238.3)	(209.6)	(38.1)	3 -	1/2 NPT	(247.7)	2.00	5.50	3 - 1/2 NPT
KKB 318									(50.8)	(139.7)	4 - 1/2 NPT
KKB 121											2 - 3/4 NPT
KKB 221	10 -	21/32 (16.7)	(289.1)	(266.7)	(44.5)	3 -	1/2 NPT	(289.1)	2.00	6.50	3 - 3/4 NPT
KKB 321									(50.8)	(165.1)	4 - 3/4 NPT
KKB 124H											2 - 1 NPT
KKB 224H	10 -	21/32 (16.7)	(322.3)	(292.1)	(23.9)	3 -	1/2 NPT	(384.0)	2.00	7.63	4 - 1 NPT
KKB 324H									(50.8)	(193.8)	6 - 1 NPT

**NOTE:** For mounting, use socket head capscrews conforming to the ASTM-574-97a.

<sup>1</sup> Number of inlets and outlets are equivalent.

(Consult factory for drawing before final layout.)

# Tension Brakes/High Heat Capacity

## Kopper Kool Brakes

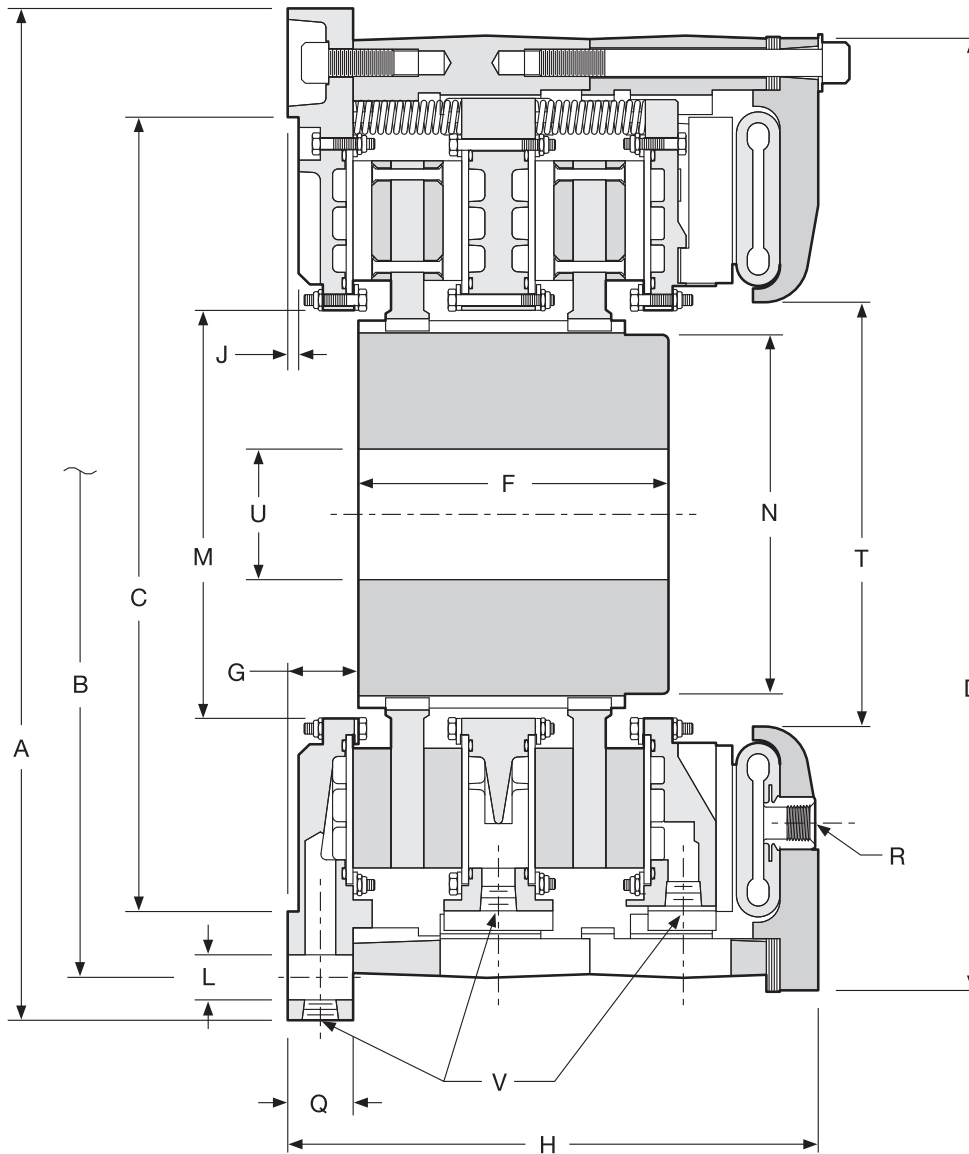

For mounting hole pattern, see following pages.  
For sizes 19 and 25 see page 88.



# Tension Brakes/High Heat Capacity

## Kopper Kool Brakes

### Dimensions: inches (mm)

Model Size ATD-	A Pilot	B Hole Circle	C Pilot	D	F	G	H	J
KKB 127	32.747 / 32.750	31.500	27.375 / 27.378	15.13	5.00 (127)	1.38	9.00 (228.6)	0.25
KKB 227	(831.77 / 831.85)	(800.10)	(695.33 / 695.40)	(384.3)	8.63 (219.2)	(35.1)	13.75 (349.3)	(6.4)
KKB 130					4.63 (117.6)		9.44 (239.8)	
KKB 230	36.997 / 37.000	35.500	30.375 / 30.378	34.75	9.25 (235)	1.38 (35.1)	14.25 (362)	0.25 (6.4)
KKB 330	(939.72 / 939.80)	(901.70)	(771.53 / 771.60)	(882.7)	13.88 (352.6)		19.00 (482.6)	
KKB 136H					5.63 (143)	1.13 (28.7)	12.63 (320.8)	
KKB 236H	43.497 / 43.500	42.000	36.375 / 36.378	44.50	11.00 (279.4)	1.43 (36.3)	19.26 (489.2)	0.25 (6.4)
KKB 336H	(1,104.82 / 1,104.90)	(1066.80)	(923.93 / 924.00)	(1,130.3)	16.63 (422.4)	1.43 (36.3)	25.76 (654.3)	
KKB 436H	44.50	42.500	36.375 / 36.378	44.50	24.75 (628.7)	1.43 (36.3)	32.26 (819.4)	0.25 (6.4)
	(1,130.3)	(1,079.50)	(923.93 / 924.00)	(1,130.3)				
KKB 346 <sup>2</sup>	58.747 / 58.750	56.750	48.000 / 48.003	56.75	20.75	2.75	29.13	0.25
	(1,492.17 / 1,492.25)	(1,441.45)	(1,219.20 / 1,219.28)	(1,441.45)	(527.1)	(69.9)	(739.9)	(6.4)

### Dimensions: inches (mm)

Model Size ATD-	L		M	N	Q	R		T	U		V <sup>1</sup> - Inlets
	No. -	Size				No. -	Size		Min.	Max.	No. -
KKB 127	14 -	21/32 (16.7)	14.13	12.50	1.75	3 -	1/2 NPT	15.13	2.50	8.00	2 - 3/4 NPT
KKB 227			(358.9)	(317.5)	(44.5)			(358.9)	(63.5)	(203.2)	3 - 3/4 NPT
KKB 130											2 - 1 NPT
KKB 230	16 -	25/32 (19.8)	15.75	14.25	2.00	4 -	1/2 NPT	17.38	2.50	9.00	4 - 1 NPT
KKB 330			(400.1)	(362)	(50.8)			(441.5)	(63.5)	(228.6)	6 - 1 NPT
KKB 136H											2 - 1.25 NPT
KKB 236H	16 -	13/16 (20.6)	16.50	14.00	1.19	4 -	1/2 NPT	17.38	6.00	9.00	4 - 1.25 NPT
KKB 336H			(419.1)	(355.6)	(30.2)			(441.5)	(152.4)	(228.6)	6 - 1.25 NPT
KKB 436H	16 -	1.06 (26.9)	16.50	14.00	1.25	4 -	1/2 NPT	17.38	6.00	9.00	8 - 1.25 NPT
			(419.1)	(355.6)	(31.8)			(441.5)	(152.4)	(228.6)	
KKB 346 <sup>2</sup>	22 -	1.03 (26.2)	29.00	24.00	3.13	4 -	1/2 NPT	30.25	8.00	16.00	6 - 1.25 NPT
			(736.6)	(609.6)	(79.5)			(768.4)	(203.2)	(406.4)	

**NOTE:** For mounting, use socket head capscrews conforming to the ASTM-574-97a.

<sup>1</sup> Number of inlets and outlets are equivalent.

(Consult factory for drawing before final layout.)

<sup>2</sup> For information purposes. Not for new applications.

# Tension Brakes/High Heat Capacity

## Kopper Kool Brakes

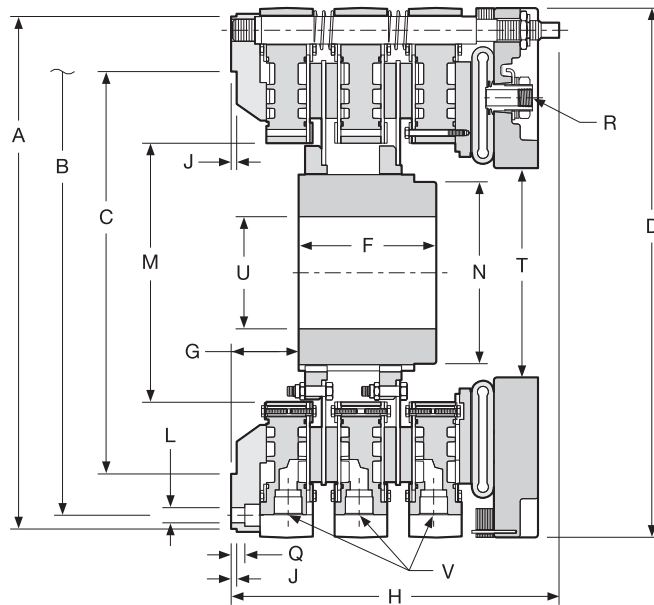

Size 19

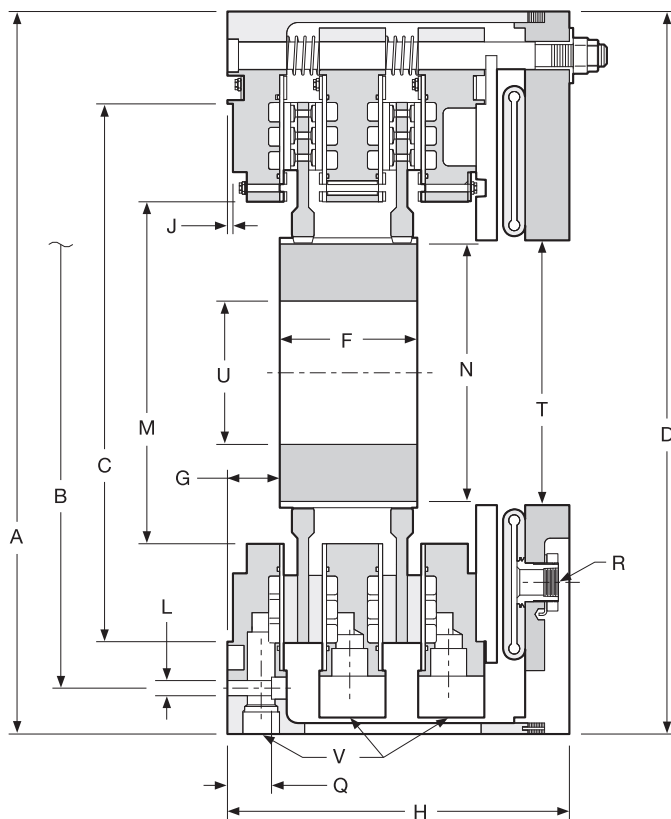

Size 25

For mounting hole pattern, see following pages.

# Tension Brakes/High Heat Capacity

## Kopper Kool Brakes

### Dimensions: inches (mm)

Model Size ATD-	A Pilot	B Hole Circle	C Pilot	D	F	G	H	J
KKB 119	23.247 / 23.250 (590.47 / 590.55)	22.000 (558.80)	18.253 / 18.256 (463.63 / 463.70)	24.00 (609.6)	3.63 (92.2)	3.00 (76.2)	11.50 (292.1)	0.25 (6.4) <sup>KKB</sup>
KKB 219					6.25 (158.8)	3.06 (77.7)	14.87 (377.7)	
KKB 125					5.00 (127)		11.00 (279)	
KKB 225	32.75 <sup>2</sup> (831.9)	28.750 (730.25)	24.375 / 24.378 (619.13 / 619.20)	32.75 (831.9)	6.25 (158.8)	2.36 (59.9)	15.50 (393.7)	0.25 (6.4)
KKB 325					13.62 (346)		19.87 (505)	

### Dimensions: inches (mm)

Model Size ATD-	L		M	N	Q	R		T	U		V <sup>1</sup> - Inlets
	No. -	Size				No. -	Size		Min.	Max.	No. - Size
KKB 119											2 - 1.31-12UN SAE "O" RING
KKB 219	12 -	11/16 (17.5)	11.75 (298.5)	8.25 (209.6)	0.62 (15.7)	4 -	1/2 NPT	9.50 (241.3)	2.75 (70)	5.50 (140)	4 - 1.31-12UN SAE "O" RING
KKB 125											2 - 1.25 NPT
KKB 225	12 -	21/32 (16.7)	15.50 (393.7)	11.67 (296.4)	2.00 (50.8)	4 -	1 NPT	12.00 (304.8)	4.00 (102)	8.13 (207)	4 - 1.25 NPT
KKB 325											6 - 1.25 NPT

**NOTE:** For mounting, use socket head capscrews conforming to the ASTM-574-97a.

<sup>1</sup> Number of inlets and outlets are equivalent.

<sup>2</sup> Not a pilot but a nominal dimension only.

(Consult factory for drawing before final layout.)

# Tension Brakes/High Heat Capacity

## Kopper Kool Brakes

### Mounting Hole Pattern

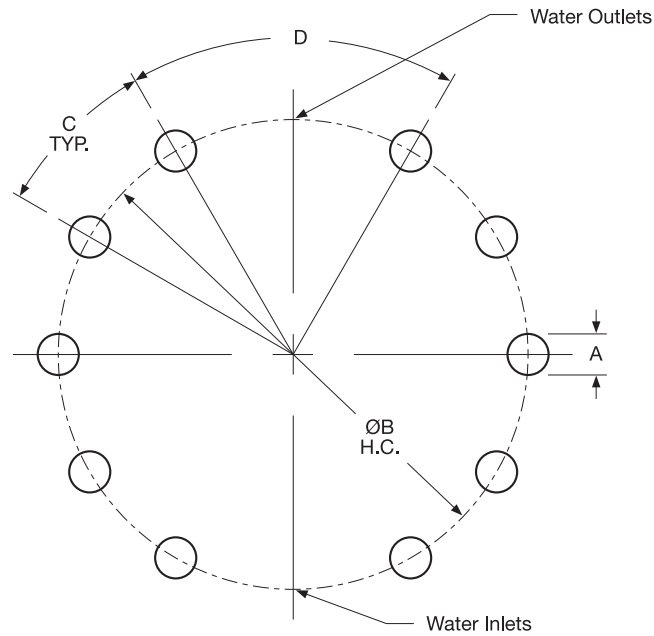

**KKB Brakes**

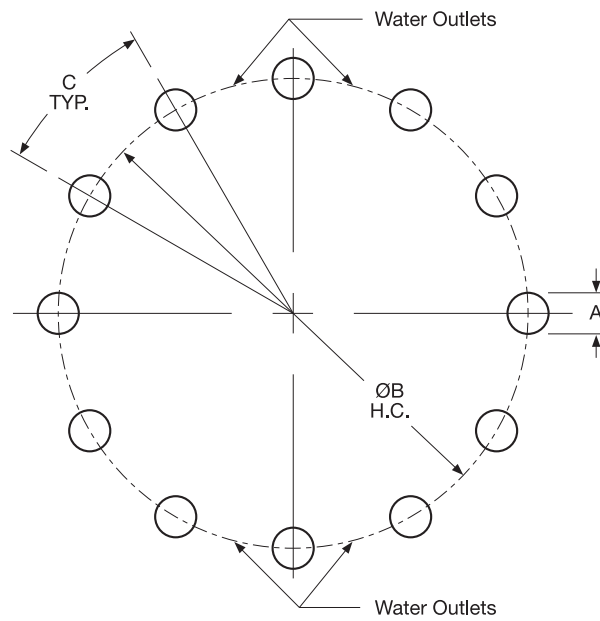

**Sizes 19 & 25**

# Tension Brakes/High Heat Capacity

## Kopper Kool Brakes Mounting Hole Pattern

### Dimensions: inches (mm)

Model KKB	No. of Mounting Holes	A Size	B Hole Circle	No. of Holes, Hole Pattern is Based	C	D
6	4	0.34 (8.6)	8.000 (203.20)	4	45°	90°
8	4	17/32 (13.5)	11.125 (282.58)	6	60°	120°
11	4	21/32 (16.7)	14.75 (374.65)	6	60°	120°
14	6	21/32 (16.7)	17.500 (444.50)	8	45°	90°
16	10	21/32 (16.7)	20.000 (508.00)	12	30°	60°
18	10	21/32 (16.7)	22.000 (558.80)	12	30°	60°
19	12	11/16 (17.5)	22.000 (558.80)	12	30°	—
21	10	21/32 (16.7)	25.500 (647.70)	12	30°	60°
24H	10	21/32 (16.7)	28.750 (730.25)	12	30°	60°
25	12	21/32 (16.7)	28.750 (730.25)	12	30°	—
27	14	21/32 (16.7)	31.500 (800.10)	16	22.5°	45°
30	16	25/32 (19.8)	35.500 (901.70)	18	20°	40°
36H	16	13/16 (20.6)	42.000 (1,066.80)	18	20°	40°
436H	16	1.06 (26.9)	42.500 (1,079.50)	18	20°	40°
46	22	1.03 (26.2)	56.750 (1,441.45)	24	15°	30°

C

# Tension Brakes/High Heat Capacity

## Kopper Kool Brakes

### Spring-Set Brakes

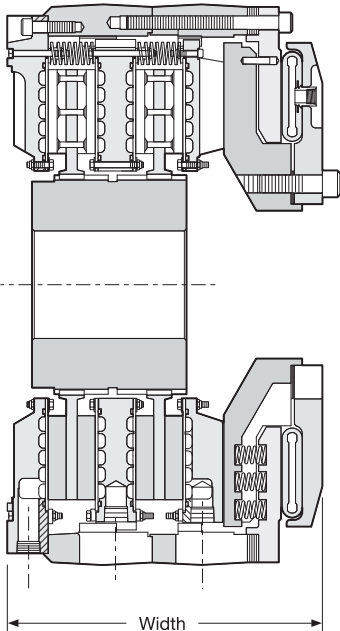

KKSS Brake

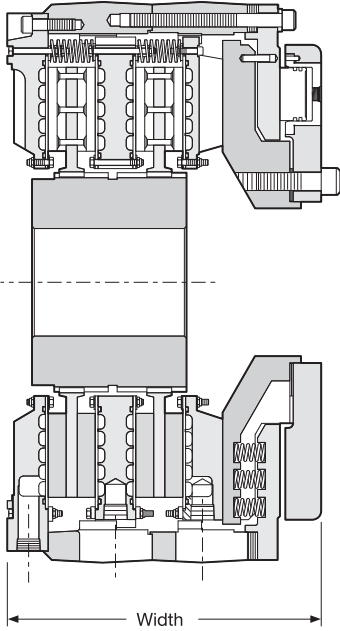

KKSS-HYD Brake

See previous pages for dimensional information.

# Tension Brakes/High Heat Capacity

## Kopper Kool Brakes Spring-Set Brakes

### Dimensions: inches (mm)

Model Size ATD-	Assembly Number	Dynamic Torque Capacity*				Width	
		lb.in.	Nm	Release Pressure		in.	(mm)
				PSI	BAR		
KKSSB 218	7-318-210-113-0	48,000	5,434	90	6.2	15.00	(381)
KKSSB 224H	7-325-210-106-0 <sup>3</sup>	104,800	11,840	75	5.2	17.59	(446.8)
KKSSB-HYD 124H	7-325-110-107-0	88,000	9,942	1,280	88.3	12.63	(320.8)
KKSSB-HYD 224H	7-325-210-107-0	160,000	18,077	1280	88.3	17.52	(445)
KKSSB 330H	7-331-310-300-0 <sup>1</sup>	748,900	84,612	100	6.9	22.69	(576.3)
KKSSB 236H <sup>4</sup>	7-337-210-304-0 <sup>2</sup>	649,400	73,370	120	8.3	22.03	(559.6)
KKSSB 336H <sup>4</sup>	7-337-310-107-0 <sup>1,2</sup>	1,177,800	133,070	100	6.9	28.60	(726.4)
KKSSB 336H <sup>4</sup>	7-337-310-106-0 <sup>2</sup>	940,600	106,270	120	8.3	28.60	(726.4)

\* Static torque will vary with temperature.

**Note:** Maximum water jacket inlet pressure is 60 PSI.

Brakes with as great as 50% higher torque capacity is available upon request.

<sup>1</sup> Current design is with enhanced linings. A unit with regular linings is available upon request.

<sup>2</sup> Current design is with the Marine Corrosion package. A Non-Marine unit is available upon request.

<sup>3</sup> Current design is without hub. A unit with hub is available upon request.

<sup>4</sup> Mounting same as 436H KK except with 42.500" (1,079.5 mm) hole circle.

Feature Differences: The KKSS brake uses air to release the brake, where as the KKSS-HYD brake uses hydraulic pressure to release the brake.

C

# Tension Brakes/High Heat Capacity

## Kopper Kool Custom Units

### KKSS Clutch

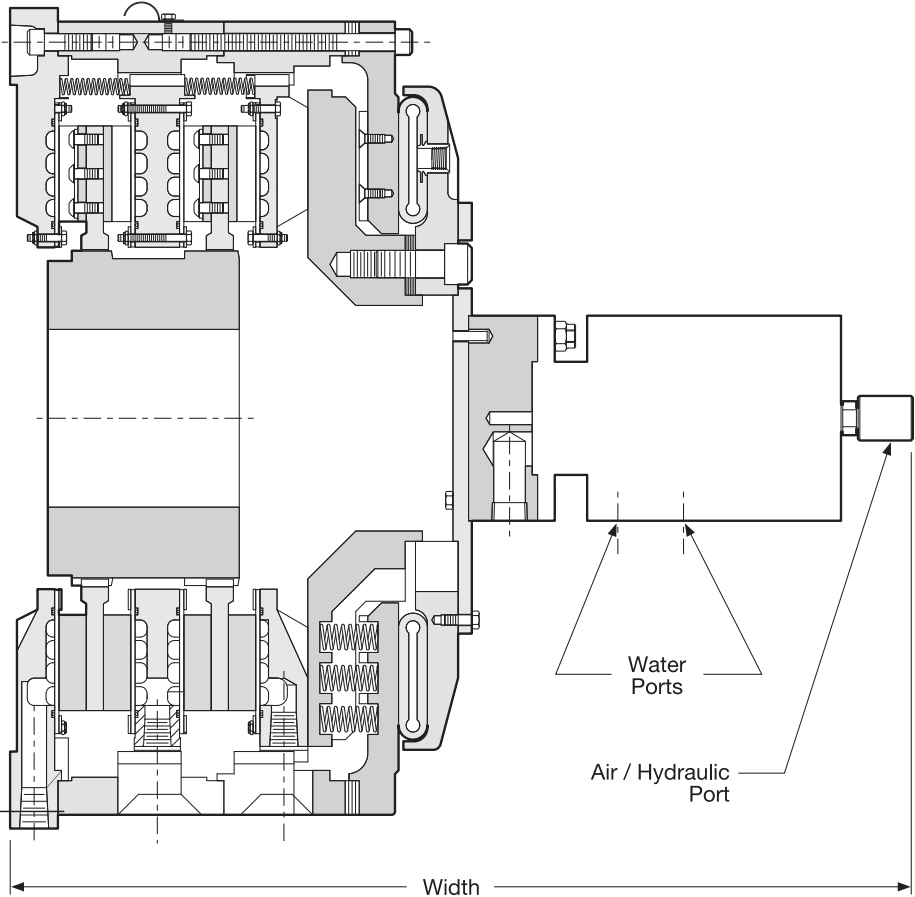

See previous pages for dimensional information.



# Tension Brakes/High Heat Capacity

## Kopper Kool Custom Units

### KKSS Clutch

#### Dimensions: inches (mm)

Model Size ATD-	Assembly Number	Dynamic Torque Capacity* with Release Pressure		Heat Capacity HP (kW)	Roto - Coupling NPT	Max. Speed		Width in.(mm)
		lb.in.(Nm)	PSI (BAR)			R/C RPM	Unit RPM	
KKSSC 224	6-324-210-102-0 <sup>2</sup>	74,250 (8,389)	75 (5.2)	347 <sup>5</sup> (260) <sup>5</sup>	1-1/4"	40	475	33.00 (838.2)
KKSSC 324	6-324-310-102-0 <sup>2</sup>	110,700 (12,507)	75 (5.2)	400 <sup>6</sup> (300) <sup>6</sup>	1-1/4"	40	475	37.58 (954.5)
KKSSC 224H	6-325-210-100-0 <sup>1,2</sup>	157,225 (17,764)	75 (5.2)	566 <sup>7</sup> (425) <sup>7</sup>	1-1/2"	250	475	38.87 (987.3)
KKSSC 324H	6-325-310-100-0 <sup>1,2</sup>	278,700 (31,488)	95 (6.6)	400 <sup>7</sup> (300) <sup>7</sup>	1-1/4"	40	475	39.03 (991.4)
KKSSC 236H	TBD <sup>2,3</sup>	542,100 (61,247)	100 (6.9)	1,300 <sup>6</sup> (975) <sup>6</sup>	2"	250	300	32.25 (819.2)
KKSSC-HYD 236H	6-337-210-100-0 <sup>2,3</sup>	542,100 (61,247)	1,450 (100.0)	1,300 <sup>6</sup> (975) <sup>6</sup>	2"	250	300	32.25 (819.2)

\* Static torque will vary with temperature.

**Note:** Maximum water jacket inlet pressure is 60 PSI.

Brakes with as great as 50% higher torque capacity is available upon request.

<sup>1</sup> Current design is with enhanced linings. A unit with regular linings is available upon request.

<sup>2</sup> Current design is with the Marine Corrosion package. A Non-Marine unit is available upon request.

<sup>3</sup> Mounting same as 436H KK except with 42.500" (1,079.5 mm) hole circle.

<sup>5</sup> Series hosing

<sup>6</sup> Parallel hosing

<sup>7</sup> Partial-parallel hosing

Feature Differences: The KKSS clutch uses air to release the clutch where as; the KKSS-HYD clutch uses hydraulic pressure to release the clutch.

# Tension Brakes/High Heat Capacity

## Series Water Hose Kits for Kopper Kool Brakes, KKB and Steel Water Cooled Brakes, SWCB

Wichita Water Hose kits contain all necessary fittings, hoses, and connections to completely plumb the brake water system. Customer needs to connect water input at the bottom of the brake and the output water connections at the top of the brake.

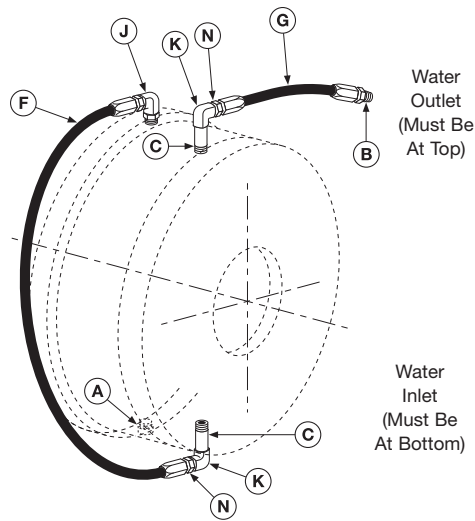

Single plate

Model Size	Water Hose ATD-	Water Hose Kit Number*	A Inlet Size	B Inlet Size	C Pipe Nipple Part Number	Qty	D Pipe Nipple Part Number	Qty	E Pipe Nipple Part Number	Qty	F Hose Part Number	Qty	G Hose Part Number	Qty
108 KKB	8-908-999-901-5	3/8" NPT	3/8" NPT	2-200-036-122-0	2	—	—	—	—	—	2-403-240-033-1	1	2-403-110-133-1	1
208 KKB	8-908-999-902-5	3/8" NPT	3/8" NPT	2-200-036-122-0	4	—	—	—	—	—	2-403-240-033-1	2	2-403-110-133-1	1
308 KKB	8-908-999-903-5	3/8" NPT	3/8" NPT	2-200-036-122-0	6	—	—	—	—	—	2-403-240-033-1	3	2-403-110-133-1	1
114 KKB	8-914-999-901-6	1/2" NPT	3/4" NPT	2-200-037-122-0	2	—	—	—	—	—	2-404-320-044-1	1	2-404-110-144-1	1
214 KKB	8-914-999-902-6	1/2" NPT	3/4" NPT	2-200-037-122-0	4	—	—	—	—	—	2-404-320-044-1	2	2-404-110-144-1	1
314 KKB	8-914-999-903-6	1/2" NPT	3/4" NPT	2-200-037-122-0	6	—	—	—	—	—	2-404-320-044-1	3	2-404-110-144-1	1
118 KKB	8-918-999-901-6	1/2" NPT	3/4" NPT	2-200-037-122-0	2	—	—	—	—	—	2-404-380-044-1	1	2-404-110-144-1	1
218 KKB	8-918-999-902-6	1/2" NPT	3/4" NPT	2-200-037-122-0	4	—	—	—	—	—	2-404-380-044-1	2	2-404-110-144-1	1
318 KKB	8-918-999-903-6	1/2" NPT	3/4" NPT	2-200-037-122-0	6	—	—	—	—	—	2-404-380-044-1	3	2-404-110-144-1	1
124H SWCB	8-924-999-901-6	1/2" NPT	3/4" NPT	2-200-060-122-0	2	—	—	—	—	—	2-404-500-044-1	1	2-404-110-144-1	1
224H SWCB	8-924-999-902-6	1/2" NPT	3/4" NPT	2-200-060-122-0	4	—	—	—	—	—	2-404-500-044-1	2	2-404-110-144-1	1
324H SWCB	8-924-999-903-6	1/2" NPT	3/4" NPT	2-200-060-122-0	6	—	—	—	—	—	2-404-500-044-1	3	2-404-110-144-1	1
124H KKB	9-925-999-901-7	1" NPT	1" NPT	2-200-051-122-0	2	—	—	—	—	—	2-405-500-055-1	1	2-405-110-155-1	1
224H KKB	8-925-999-902-7	1" NPT	1" NPT	2-200-051-122-0	4	2-200-082-122-0	2	2-200-017-122-0	1	—	2-405-500-055-1	2	2-405-110-155-1	1
324H KKB	8-925-999-903-7	1" NPT	1" NPT	2-200-051-122-0	6	2-200-082-122-0	4	2-200-017-122-0	1	—	2-405-500-055-1	3	2-405-110-155-1	1
130 SWCB	8-930-999-901-7	3/4" NPT	1" NPT	2-200-061-122-0	2	—	—	—	—	—	2-405-620-055-1	1	2-405-200-155-1	1
230 SWCB	8-930-999-902-7	3/4" NPT	1" NPT	2-200-061-122-0	4	—	—	—	—	—	2-405-620-055-1	2	2-405-200-155-1	1
330 SWCB	8-930-999-903-7	3/4" NPT	1" NPT	2-200-061-122-0	6	—	—	—	—	—	2-405-620-055-1	3	2-405-200-155-1	1
130 KKB	8-930-999-901-9	1" NPT	1-1/2" NPT	2-200-062-122-0	2	—	—	—	—	—	2-407-620-077-1	1	2-407-200-177-1	1
230 KKB	8-930-999-902-9	1" NPT	1-1/2" NPT	2-200-062-122-0	4	2-200-092-122-0	2	2-200-017-122-0	1	—	2-407-620-077-1	4	2-407-200-177-1	1
330 KKB	8-930-999-903-9	1" NPT	1-1/2" NPT	2-200-062-122-0	6	2-200-092-122-0	4	2-200-017-122-0	1	—	2-407-620-077-1	3	2-407-200-177-1	1
136 SWCB	8-936-999-901-7	3/4" NPT	1" NPT	2-200-061-122-0	2	—	—	—	—	—	2-405-680-055-1	1	2-405-200-155-1	1
236 SWCB	8-936-999-902-7	3/4" NPT	1" NPT	2-200-061-122-0	4	—	—	—	—	—	2-405-680-055-1	2	2-405-200-155-1	1
336 SWCB	8-936-999-903-7	3/4" NPT	1" NPT	2-200-061-122-0	6	—	—	—	—	—	2-405-680-055-1	3	2-405-200-155-1	1
136H KKB	8-937-999-901-9	1-1/4" NPT	1-1/2" NPT	2-200-063-122-0	2	—	—	—	—	—	2-407-680-077-1	1	2-407-200-155-1	1
236H KKB	8-937-999-902-9	1-1/4" NPT	1-1/2" NPT	2-200-063-122-0	4	2-200-104-122-0	2	2-200-018-122-0	1	—	2-407-680-077-1	2	2-407-200-155-1	1
336H KKB	8-937-999-903-9	1-1/4" NPT	1-1/2" NPT	2-200-063-122-0	6	2-200-104-122-0	4	2-200-018-122-0	1	—	2-407-680-077-1	3	2-407-200-155-1	1

\* Denotes complete hose kit



# Tension Brakes/High Heat Capacity

## Series Water Hose Kits for Kopper Kool Brakes, KKB and Steel Water Cooled Brakes, SWCB

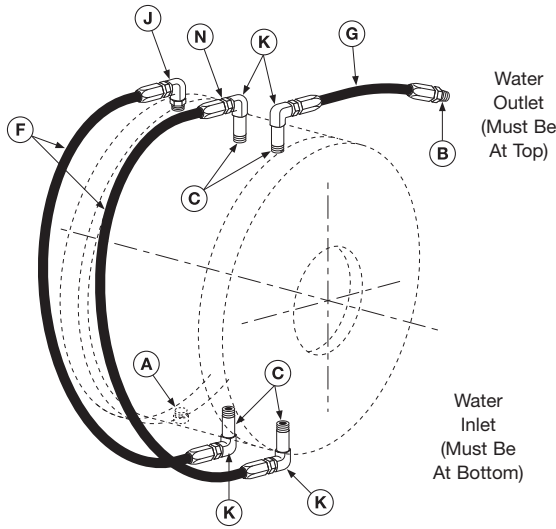

**Double Plate**  
Sizes 208 through 318

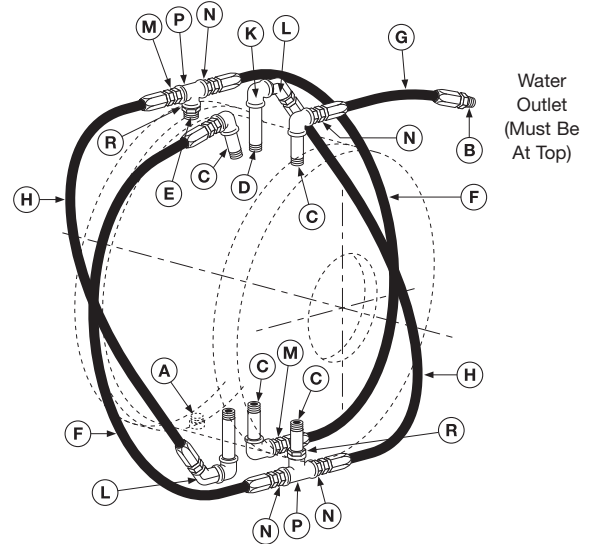

**Double Plate**  
Sizes 224H through 336H

Model Size	H Hose Part Number	H Qty	J Elbow 90 Part Number	J Qty	K Elbow 90 Part Number	K Qty	L Elbow 45 Part Number	L Qty	M Adaptor Part Number	M Qty	N Adaptor Part Number	N Qty	P Pipe Tee Part Number	P Qty
108 KKB	—	—	2-303-027-020-0	1	2-302-027-020-0	2	—	—	—	—	—	—	—	—
208 KKB	—	—	2-303-027-020-0	1	2-302-027-020-0	4	—	—	—	—	—	—	—	—
308 KKB	—	—	2-303-027-020-0	1	2-302-027-020-0	6	—	—	—	—	—	—	—	—
114 KKB	—	—	2-303-039-020-0	1	2-302-039-020-0	2	—	—	—	—	—	—	—	—
214 KKB	—	—	2-303-039-020-0	1	2-302-039-020-0	4	—	—	—	—	—	—	—	—
314 KKB	—	—	2-303-039-020-0	1	2-302-039-020-0	6	—	—	—	—	—	—	—	—
118 KKB	—	—	2-303-039-020-0	1	2-302-039-202-0	4	—	—	—	—	—	—	—	—
218 KKB	—	—	2-303-039-020-0	1	2-302-039-202-0	6	—	—	—	—	—	—	—	—
318 KKB	—	—	2-303-039-020-0	1	2-302-039-202-0	4	—	—	—	—	—	—	—	—
124H SWCB	—	—	2-303-039-020-0	1	2-302-039-202-0	6	—	—	—	—	—	—	—	—
224H SWCB	—	—	2-303-039-020-0	1	2-302-039-202-0	6	—	—	—	—	—	—	—	—
324H SWCB	—	—	2-303-062-001-0	1	2-302-062-001-0	2	—	—	—	—	—	—	—	—
124H KKB	2-405-500-055-1	2	—	—	2-302-062-001-0	5	2-307-062-001-0	2	2-300-062-001-0	2	2-300-062-001-0	5	2-214-041-412-0	2
224H KKB	2-405-500-055-1	3	—	—	2-302-062-001-0	9	2-307-062-001-0	4	2-300-062-001-0	4	2-300-062-001-0	5	2-214-041-412-0	2
324H KKB	—	—	2-303-051-001-0	1	2-210-036-112-0	2	—	—	—	—	—	—	2-300-062-001-0	2
130 SWCB	—	—	2-203-051-001-0	1	2-210-036-112-0	4	—	—	—	—	—	—	2-300-062-001-0	4
230 SWCB	—	—	2-303-064-001-0	1	2-210-041-112-0	6	—	—	—	—	—	—	2-300-062-001-0	6
330 SWCB	—	—	2-303-064-001-0	1	2-210-041-112-0	2	—	—	—	—	—	—	2-300-064-001-0	2
130 KKB	—	—	2-210-041-112-0	5	2-307-064-001-0	2	2-300-064-001-0	2	2-300-064-001-0	5	2-214-041-112-0	2	—	—
230 KKB	—	—	2-407-620-077-1	3	2-210-041-112-0	9	2-307-064-001-0	2	2-300-064-001-0	4	2-300-064-001-0	5	2-214-041-112-0	2
330 KKB	—	—	2-303-051-001-0	1	2-210-036-112-0	2	—	—	—	—	—	—	2-300-062-001-0	2
136 SWCB	—	—	2-303-051-001-0	1	2-210-036-112-0	4	—	—	—	—	—	—	2-300-062-001-0	4
236 SWCB	—	—	2-303-051-001-0	1	2-210-036-112-0	6	—	—	—	—	—	—	2-300-062-001-0	6
336 SWCB	—	—	2-303-075-001-0	1	2-210-046-112-0	2	—	—	—	—	—	—	2-300-075-001-0	2
136H KKB	2-407-660-077-1	2	—	—	2-210-046-112-0	5	2-300-075-001-0	2	2-300-075-001-0	2	2-300-075-001-0	5	2-214-073-112-0	2
236H KKB	2-407-660-077-1	3	—	—	2-210-046-112-0	9	2-300-075-001-0	4	2-300-075-001-0	4	2-300-075-001-0	5	2-214-073-112-0	2
336H KKB	—	—	—	—	—	—	—	—	—	—	—	—	—	—

# Tension Brakes/High Heat Capacity

## Kopper Kool Brakes

### Parallel Water Hose Kits

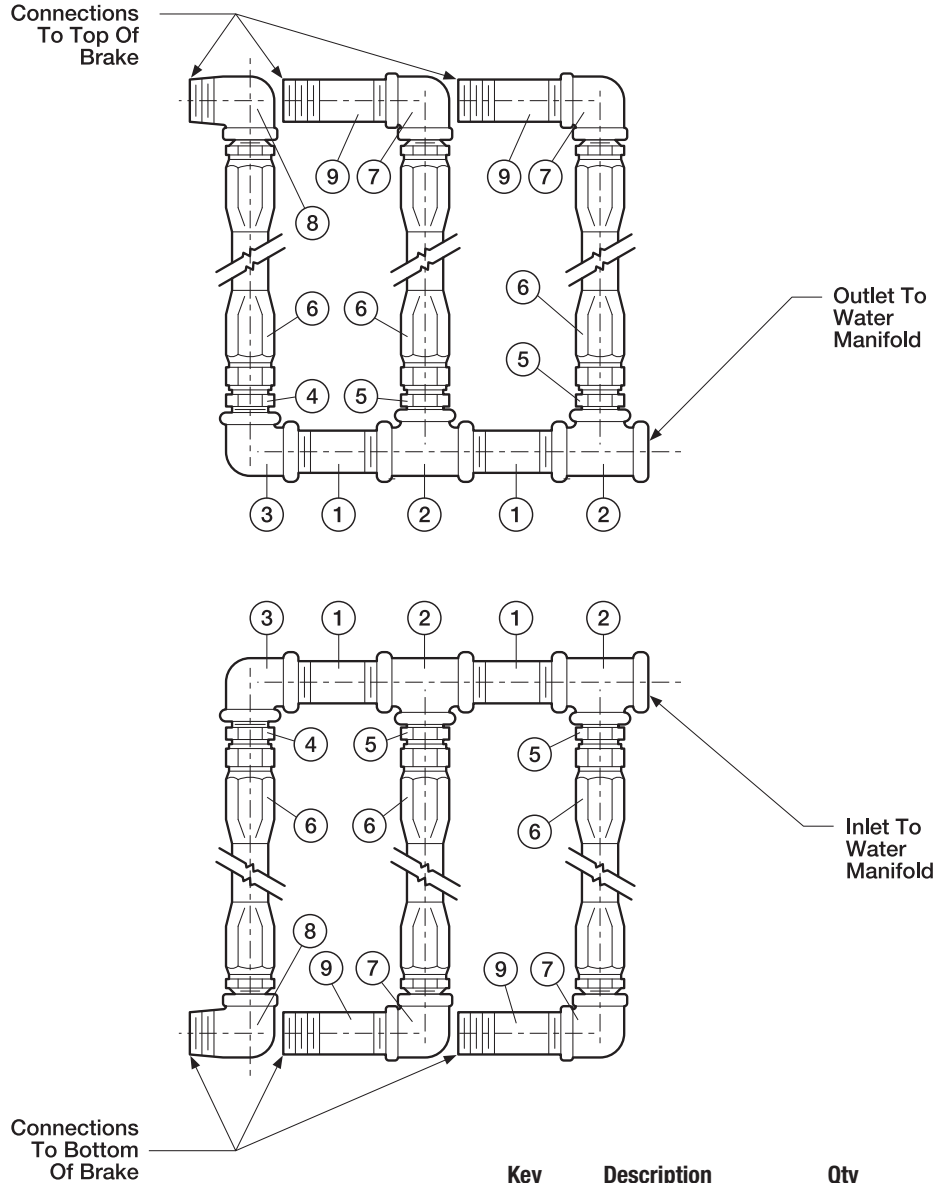

Key	Description	Qty
1	Nipple	4
2	Pipe Tee	4
3	Elbow	2
4	Straight Adapter	2
5	Straight Adapter	4
6	Hose Rigid to Swivel	6
7	Elbow	2
8	Street Elbow	2
9	Nipple	4

# Tension Brakes/High Heat Capacity

## Kopper Kool Brakes Parallel Water Hose Kits

### Dimensions: inches (mm)

Model Size ATD-	Parallel Water Hose Kit	Manifold Inlet - Outlet Size	Water Jacket Inlet - Outlet Size
KKB 208	8-908-999-904-5	3/4" NPT	3/8" NPT
KKB 308	8-908-999-905-5	3/4" NPT	
KKB 111	8-916-999-905-5	3/4" NPT	
KKB 211	8-916-999-903-5	3/4" NPT	1/2" NPT
KKB 311	8-916-999-904-5	1" NPT	
KKB 114	8-916-999-905-5	3/4" NPT	
KKB 214	8-916-999-903-5	3/4" NPT	1/2" NPT
KKB 314	8-916-999-904-5	1" NPT	
KKB 116	8-916-999-905-5	3/4" NPT	
KKB 216	8-916-999-903-5	3/4" NPT	1/2" NPT
KKB 316	8-916-999-904-5	1" NPT	
KKB 118	8-916-999-905-5	3/4" NPT	
KKB 218	8-916-999-903-5	3/4" NPT	1/2" NPT
KKB 318	8-916-999-904-5	1" NPT	
KKB 119	8-919-999-906-7	1-1/4" NPT	1-5/16" -12 UN SAE "O" – RING
KKB 219	8-919-999-907-7	2" NPT	

C

# Tension Brakes/High Heat Capacity

## Kopper Kool Brakes

### 3-Way Roto-Coupling (for water-cooled Clutches)

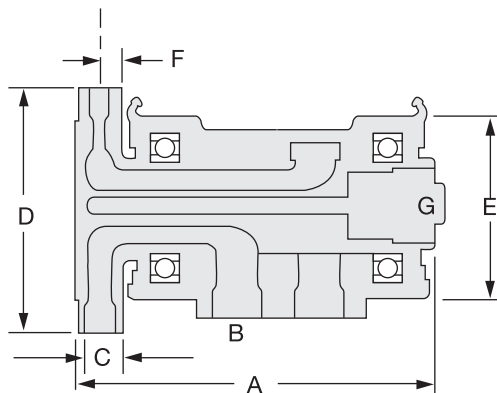
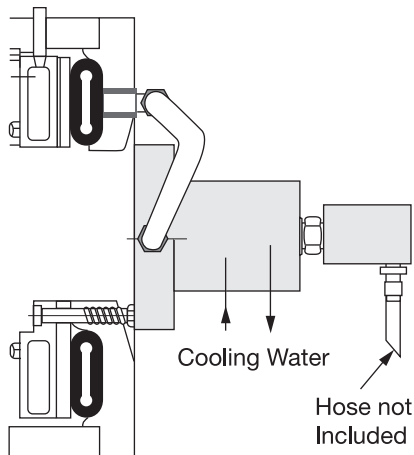

8-442-774-006-1

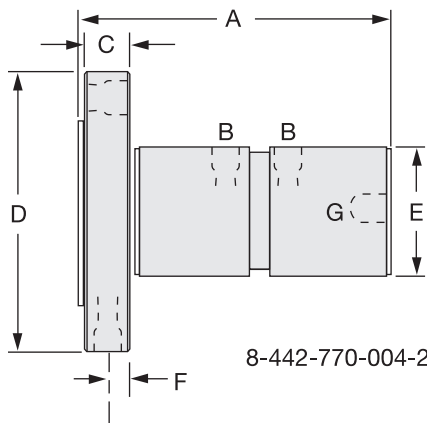

8-442-770-004-2

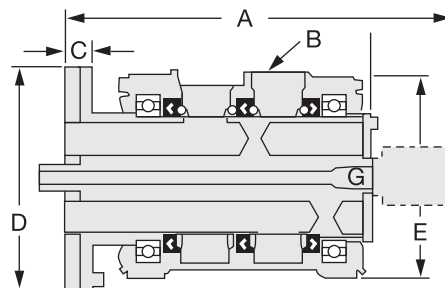

8-442-776-000-1

### Dimensions: inches (mm)

Wichita Part No.	A	B	C	D	E	F	Thread Size	
							G	
8-442-770-004-2	7.250	3/8"-18 NPT	1.00	6.50	3.000	.50	5/8"-18	
8-442-774-006-1	11.000	1-1/4"-11-1/2 NPT	1.375	7.25	5.375	.687	1/4" NPT	
8-442-776-000-1	18.875	2"-11-1/2 NPT	1.250	10.00	9.000	—	1"-14	



# Tension Brakes/High Heat Capacity

## Kopper Kool Brake Air Hose Kits

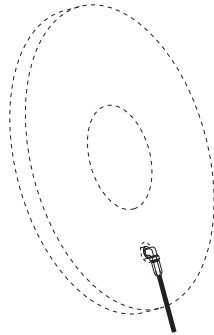

Model	Part Number
8"	8-908-912-100-5 8-908-924-100-5 QRV

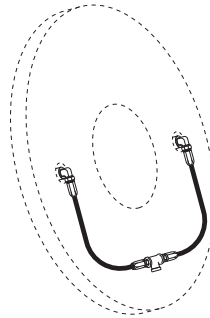

Model	Part Number
6"	8-906-912-200-4 8-906-931-201-5 QRV
8"	8-908-913-200-5 8-908-931-200-5 QRV
11"	8-911-913-200-5 8-911-931-200-5 QRV
14"	8-914-913-200-5 8-914-921-200-5 QRV
16"	8-916-913-200-5 8-916-921-200-5 QRV

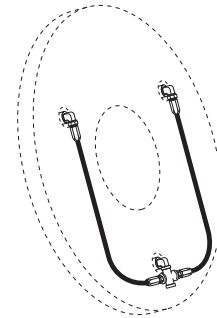

Model	Part Number
18"	8-918-912-200-5 8-918-931-200-5 QRV
21"	8-921-913-200-5 8-921-931-200-5 QRV
24"	8-924-913-200-5 8-924-931-200-5 QRV
27"	8-927-913-200-5 8-927-921-200-5 QRV

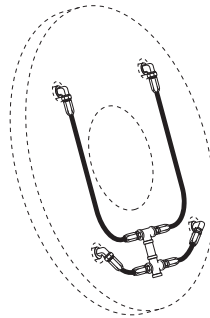

Model	Part Number
30"	8-930-913-400-5 8-930-931-400-5 QRV
36"	8-936-913-400-6 8-936-931-400-6 QRV
42"	8-942-913-400-6 8-924-931-400-6 QRV
48"	8-948-912-400-6 8-948-923-400-6 QRV

Air hose kits contain all necessary parts (fittings, hoses and extensions) to completely plumb the brake air system.

Optional Quick Release Valves can replace elbows on most units (see page 121).

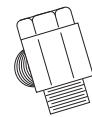

# Tension Brakes/Air Cooled

## Mistral Brakes



### Mounting Ease

Three bolts mount the brake to the arm of the mill roll stand or machine frame and an optional pilot location makes fitting to both new and existing machines a simple operation.

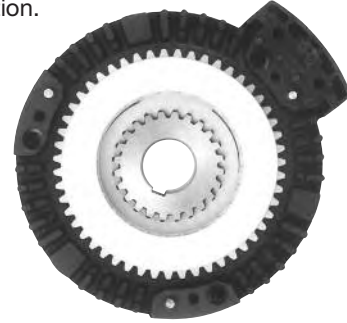

Wichita Mistral pneumatic tension brake is attuned to the needs of the corrugating market for which it was originally designed. It is also a versatile product which is finding favor in additional tensioning applications.

Wichita designers and engineers consulted extensively with mill roll stand manufacturers and users to offer a tension brake ideally suited to the needs of this particular market. The

result is a compact, high performance, versatile brake capable of handling the tensioning needs of the latest machine designs, as well as existing equipment. The Mistral paves the way for increasing line speeds by 5.4 ft./sec. from 810 ft./min. (or slower) to 1,140 ft./min.

### Wear Indicator

A brake wear indicator, which is conveniently located for easy visual inspection, means no down time to check remaining friction material life.

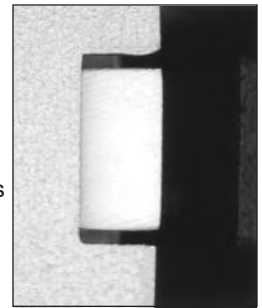

### Easy Connection

Air and electrical connections are easily accessible for fast, simple installation and maintenance.

### Compact Design, Modern Styling

Mistral brakes are compact at only 11.6" or 16.1" in diameter. Their size facilitates the pickup of small, part reels used in short batch runs. For automatic reel loading machines, Mistral offers optional infrared and speed sensor installation within the brake. And their modern, industrial styling enhances the appearance of any machine on which they are used.

### Fine Tuning

Each brake may be specified with a varying number of pneumatic actuators, allowing precise selection of brake torque capacity for optimum tension control.

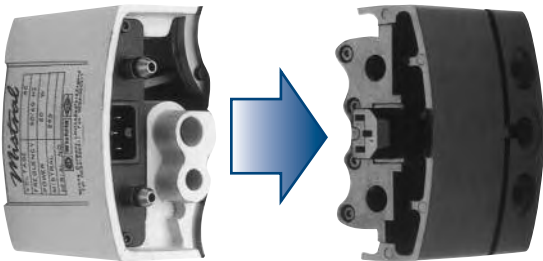

### Safety

Mistral's integral guarding eliminates the cost and effort of installing external guards. Operator safety is further enhanced by automatic air and electric disconnects when the front cover is removed.





# Tension Brakes/Air Cooled

## Mistral Brakes

### Front Cover Removal

By removing just three cap screws, the Mistral's front cover can be detached for easy and fast access to internal parts. Cover removal automatically disconnects both air and electricity.

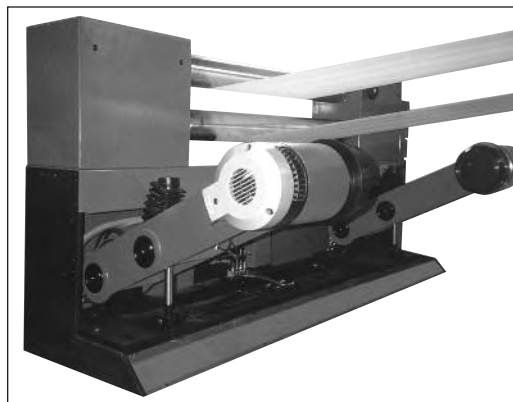

### Integral Cooling

A rugged, high performance, low energy usage fan is housed within the brake for high heat dissipation — a must for increased productivity through controlled tension at many roll speeds.

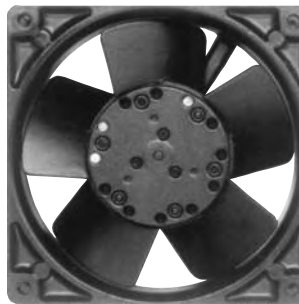

### Performance Curve

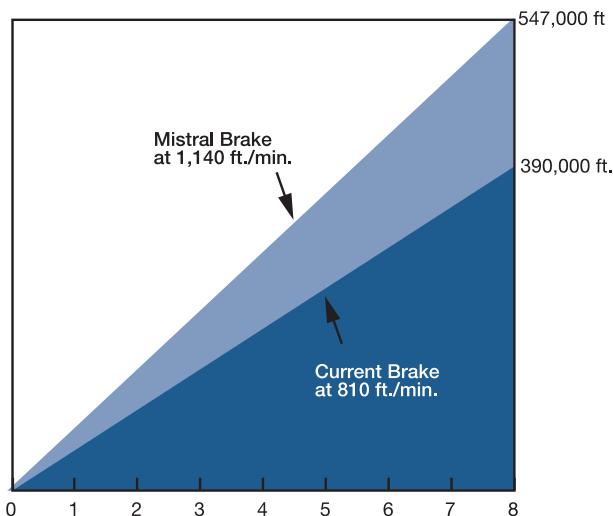

### Fan Data and Connection Data

Model	Fan Voltages	Fan Power	Electric	Pneum.
200	220 VAC or/order	20W	M16	1/8 BSP
	110 VAC or/order		PG9	1/8 BSP
	24 VDC		3/8 NPT	1/8 NPT
280	220 VAC or/order	18W	M16	1/8 BSP
	110 VAC or/order		PG9	1/8 BSP
	24 VDC		3/8 NPT	1/8 NPT

Model	Dynamic Slipping Torque Capacity				Heat Transfer Capacity				Maximum Speed Rev./Min.	Inertia of Rotating Parts		Weight				Fan Power Rating W
	Air Pressure				Continuous Operation		:30 On/:30 Off Operation			WR <sup>2</sup> lb.ft. <sup>2</sup>	J=mr <sup>2</sup> (kgm <sup>2</sup> )	Total Brake		Rotating Parts		
	Min.* 3 PSI	Max. 80 PSI	Min.* 0.2 BAR	Max. 5.5 BAR	HP	(kW)	HP	(kW)				lb.	(kg.)	lb.	(kg.)	
Mistral	Min.* 3 PSI	Max. 80 PSI	Min.* 0.2 BAR	Max. 5.5 BAR	HP	(kW)	HP	(kW)	Rev./Min.	lb.ft. <sup>2</sup>	(kgm <sup>2</sup> )	lb.	(kg.)	lb.	(kg.)	W
200/2/LC	35	1,770	(4)	(200)	3.2	(2.4)	3.5	(2.6)	2,860	0.40	(0.017)	77	(35)	9.92	(4.5)	20
200/2	45	2,655	(5)	(300)	3.2	(2.4)	3.5	(2.6)	2,860	0.40	(0.017)	77	(35)	9.92	(4.5)	20
200/4/LC	35*	3,540	(4*)	(400)	3.2	(2.4)	3.5	(2.6)	2,860	0.40	(0.017)	77	(35)	9.92	(4.5)	20
200/4	45*	5,310	(5*)	(600)	3.2	(2.4)	3.5	(2.6)	2,860	0.40	(0.017)	77	(35)	9.92	(4.5)	20
200/6/LC	35*	5,310	(4*)	(600)	3.2	(2.4)	3.5	(2.6)	2,860	0.40	(0.017)	77	(35)	9.92	(4.5)	20
200/6	45*	7,965	(5*)	(900)	3.2	(2.4)	3.5	(2.6)	2,860	0.40	(0.017)	77	(35)	9.92	(4.5)	20
280/3/LC	45	3,540	(5)	(400)	6.4	(4.8)	7	(5.2)	2,090	1.80	(0.076)	110	(50)	20.72	(9.4)	25
280/3	55	5,310	(6)	(600)	6.4	(4.8)	7	(5.2)	2,090	1.80	(0.076)	110	(50)	20.72	(9.4)	25
280/6/LC	45*	7,080	(5*)	(800)	6.4	(4.8)	7	(5.2)	2,090	1.80	(0.076)	110	(50)	20.72	(9.4)	25
280/6	55*	10,620	(6*)	(1,200)	6.4	(4.8)	7	(5.2)	2,090	1.80	(0.076)	110	(50)	20.72	(9.4)	25
280/9/LC	45*	10,620	(5*)	(1,200)	6.4	(4.8)	7	(5.2)	2,090	1.80	(0.076)	110	(50)	20.72	(9.4)	25
280/9	55*	15,930	(6*)	(1,800)	6.4	(4.8)	7	(5.2)	2,090	1.80	(0.076)	110	(50)	20.72	(9.4)	25

\* With only one set of actuators engaged

# Tension Brakes/Air Cooled

## Mistral Brakes

### Selecting a Mistral Brake for a Corrugator Tension – unwind application

To properly select a tension brake for an unwind application the following information is needed.

#### Application Data

Max. Roll Dia. . . . . 48 in.  
 Max. Web Width. . . . . 36 in.  
 Max. Web Speed . . . . . 1200 FPM  
 Max. Tension. . . . . 2 PLI  
 Shaft Size . . . . . 2 in.  
 Min. Roll Dia. . . . . 6 in.  
 Min. Web Width . . . . . 36 in.  
 Min. Web Speed . . . . . 1000 FPM  
 Min. Tension . . . . . 1 PLI  
 Air Pressure Available. . . . . 80 PSI

#### Calculations

Using the calculations below, consult Specifications Chart, page 103.

The brake selected for this application is a Mistral 200/2 with 2-1/4 inch bore.

$$\begin{aligned} \text{Max. Tension} &= \text{Max. PLI} \times \text{Max. Web Width} \\ &= 2 \times 36 = 72 \text{ lbs.} \end{aligned}$$

$$\begin{aligned} \text{Max. Torque} &= \frac{\text{Max. Tension} \times \text{Max. Roll Dia.}}{2} \\ &= \frac{72 \times 48}{2} = 1,728 \text{ lb.in.} \end{aligned}$$

$$\begin{aligned} \text{Max. RPM} &= \frac{\text{Max. Web Speed} \times 3.82}{\text{Min. Roll Dia.}} \\ &= \frac{1,200 \times 3.82}{6} = 764 \text{ RPM} \end{aligned}$$

$$\begin{aligned} \text{Heat HP} &= \frac{\text{Max. Tension} \times \text{Max. Web Speed}}{33,000} \\ &= \frac{72 \times 1,200}{33,000} = 2.6 \text{ Heat HP} \end{aligned}$$

$$\begin{aligned} \text{Min. Tension} &= \text{Min. PLI} \times \text{Min. Web Width} \\ &= 1 \times 36 = 36 \text{ lbs.} \end{aligned}$$

$$\begin{aligned} \text{Min. Torque} &= \frac{\text{Min. Tension} \times \text{Min. Roll Dia.}}{2} \\ &= \frac{36 \times 6}{2} = 108 \text{ lb.in.} \end{aligned}$$

$$\begin{aligned} \text{Min. RPM} &= \frac{\text{Min. Web Speed} \times 3.82}{\text{Max. Roll Dia.}} \\ &= \frac{1,000 \times 3.82}{48} = 79 \text{ RPM} \end{aligned}$$

### How to Select

1. Check the required torque versus the available actuators' torque capacities. The Mistral 200/2/LC has a torque capacity of 1,180 lb.in. at 80 PSI. The torque requirement is 1,728 lb.in. and therefore the Mistral 200/2/LC has insufficient torque capacity. However, the 200/2 has sufficient torque capacity.
2. Check thermal requirement. The requirement is 2.6 heat HP. All the Mistral 200's are capable of 3.2 heat HP.
3. Check Maximum Bore. The requirement is 2.00 inches. The Mistral 200's maximum bore is 2.25 inches.
4. Check Maximum RPM. The requirement is 764 RPM. The maximum RPM for the Mistral 200's is 2,860 RPM.

$$\begin{aligned} \text{Max. Air Pressure} \\ \text{Required} &= \frac{\text{Max. Torque} \times 80 \text{ PSI}}{\text{Catalog Torque Rating}} \\ &= \frac{1,728 \times 80}{1,770} = 78 \text{ PSI} \end{aligned}$$

$$\begin{aligned} \text{Min. Air Pressure} \\ \text{Required} &= \frac{\text{Min. Torque} \times 80 \text{ PSI}}{\text{Catalog Torque Rating}} \\ &= \frac{108 \times 80}{1,770} \\ &= 4.8 \text{ PSI} \end{aligned}$$

# Tension Brakes/Air Cooled

## Mistral Brakes

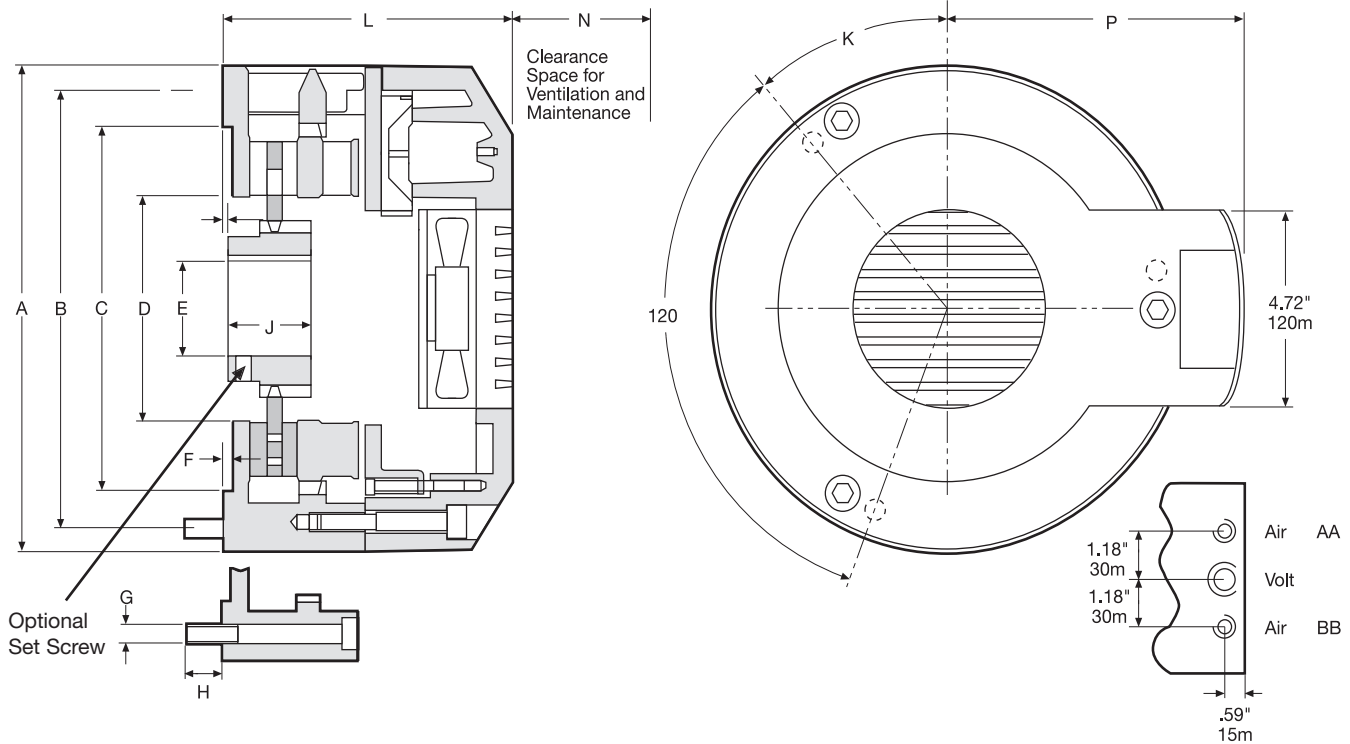

### Dimensions: inches (mm)

Model	A	B H.C.	F	G	H	J	K DEG	L	M	N	P
200	11.61 (295)	10.236 (260)	.24 (6)	1/2 (M12)	.98 (25)	1.97 (50)	40° (40°)	7.01 (178)	N/A (N/A)	2.76 (70)	7.19 (182.5)
280	16.14 (410)	13.976 (355)	0 (0)	5/8 (M16)	1.18 (30)	2.36 (60)	20° (20°)	7.56 (192)	0.37 (9.5)	3.15 (80)	9.47 (240.5)

### Pilot Mounting Dimensions "C" and "D" (mm)

Model	Mounting Pilot	Mounting Bolts Qty. and Size
	Dim. "C"	
200	8.661 +.003/-0.000 (220 +.08/-0.00)	3 @ 1/2 - 13 UNC (3 @ M12 x 1-3/4)
	Dim. "D"	
280	6.890 +.003/-0.000 (175 +.08/-0.00)	3 @ 5/8 - 11 UNC (3 @ M16 x 2)

### Actuator/Inlet

Model	No. of Actuators	No. of Air Inlets	No. of Actuators Per Air Inlets	
			AA	BB
200/2	2	2	2	0
200/4	4	2	2	2
200/6	6	2	2	4
280/3	3	2	3	0
280/6	6	2	3	3
280/9	9	2	3	6

### Bore and Keyway Dimension "E" (mm)

Model	Minimum Bore (No Keyway)	Maximum Bore with Keyway	
200	1.00 (25)	2-3/8 (60)	5/8 x 7/32 (18 x 4.4)
280	1.00 (25)	2-5/8 (65)	3/4 x 1/4 (18 x 4.4)

**Note:** For mounting, use socket head capscrews conforming to the ASTM-574-97a or ASTM-574M-97a (Metric Version).

# Tension Brakes/Air Cooled

## ModEvo Tension Brakes

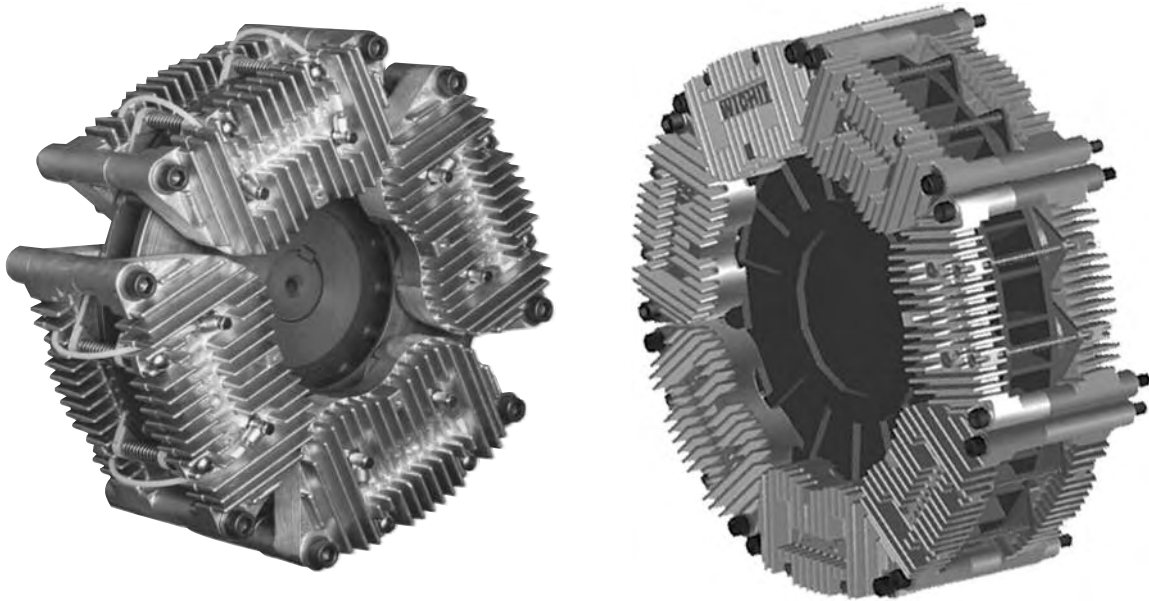

### Brake Discs and Cooling

The ModEvo brake disc was developed at the Bedford, UK factory using Finite Element Analysis techniques to ensure maximum strength with minimum weight. The design is optimized to make best use of the cooling air available at slow speeds, and being bidirectional, it achieves high heat dissipation capacity in either rotational direction, unlike some other brakes. An optional electric cooling fan is available where space is limited or more extreme heat handling is required.

Available in five sizes: 250 mm, 300 mm, 350 mm, 400 mm and 450 mm diameters, all discs are the same thickness and use the same brake modules and actuators. Each disc can be specified with a minimum of a single module, up to the maximum number of modules that can be fitted

around the disc. This allows torque-handling capabilities ranging from a maximum of 659 lb.ft. for the 250 mm disc, up to 3181 lb.ft. for the 450 mm disc.

**NOTE:** If using a high speed ductile iron disc the catalog heat rating should be reduced by 10% as the thermal conductivity of the ductile iron is less than grey cast iron.

Maximum Rotational Speed		
Disc Diameter mm	Standard Speed rev./min.	High Speed rev./min.
250	2,250	3,375
300	1,900	2,850
350	1,650	2,475
400	1,450	2,175
450	1,250	1,875

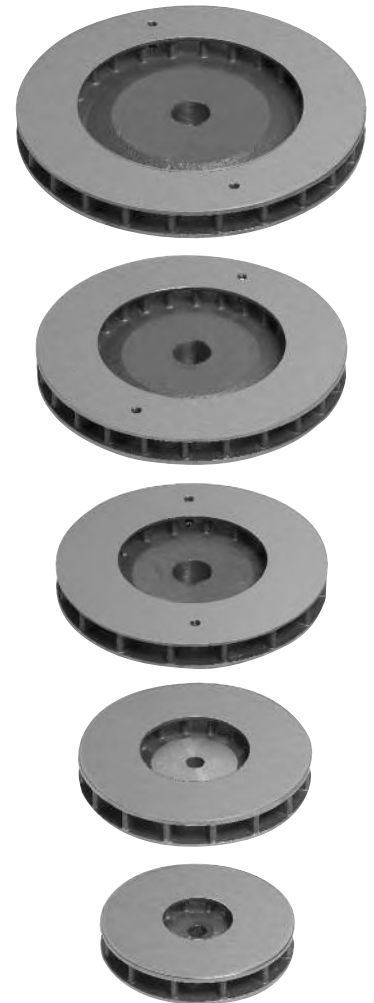

# Tension Brakes/Air Cooled

## ModEvo Tension Brakes

### Actuator Options

Newly developed rolling diaphragm actuators are used in ModEvo, producing more force than previous designs to allow higher torque ratings. However, the sensitivity for which rolling diaphragms are favored is not compromised. Three actuator options are available, offering clamping forces of 100%, 60% or 25%.

The finned, die cast aluminum brake module is common to all brake disc diameters. Each module houses two pairs of actuators, and allows friction pads to be changed quickly without dismantling the module.



100%



60%



25%

### Friction Pad Options

To provide maximum flexibility when selecting the required torque/tension range for an application, two pad options are available, with different coefficients of frictions: Low ( $\mu=0.20$ ), color-coded orange; Standard ( $\mu=0.35$ ), color-coded grey. Pad types may be mixed within a single brake assembly to provide an exact match to the machine requirements.



### Optional Guard

The optional guard has a plastic front with 'ModEvo' molded in and a metal ventilated perimeter.

Mounting is by four brackets on customer's machine frame.

The center of the guard is designed such that it may be cut-out by customer to suit the diameter of the shaft in through-shaft installations.



### ModEvo 300/8 with Fan

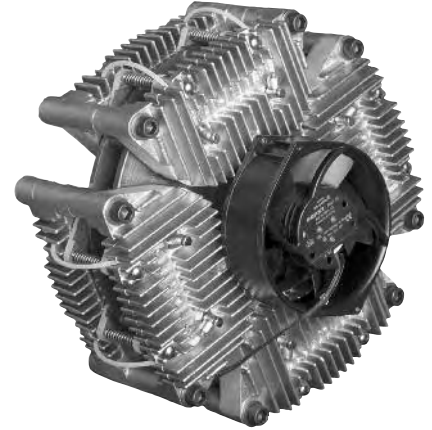

Brake Size (fan Diameter)	24v DC	115v AC	230v AC
250 (150 mm)	Yes	Yes	Yes
300 (150 mm)	Yes	Yes	Yes
350 (150 mm)	Yes	Yes	Yes
400 (150 mm)	Yes	Yes	Yes
(200 mm)	not available	Yes	Yes
450 (150 mm)	Yes	Yes	Yes
(200 mm)	not available	Yes	Yes
(250 mm)	not available	Yes	Yes

# Tension Brakes/Air Cooled

## ModEvo Tension Brakes

### ModEvo Model 250

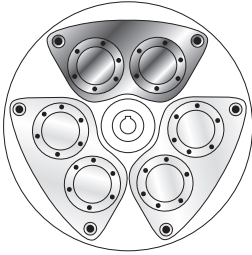

Model	Minimum Torques					
	Minimum (3 PSI) (0.2 Bars) <sup>1</sup>					
	lb.ft.(Nm)					
	LC <sup>2</sup>	Std <sup>3</sup>	LC <sup>2</sup>	Std <sup>3</sup>	LC <sup>2</sup>	Std <sup>3</sup>
	25% Actuators		60% Actuators		100 % Actuators	
250/1	0.6 (0.8)	0.93 (1.3)	1.3 (1.8)	2.2 (3)	2.2 (3)	3.7 (5)
250/2*	1.1 (1.5)	1.9 (2.5)	2.6 (3.6)	4.4 (6)	4.4 (6)	7.4 (10)
250/4*	2.2 (3)	3.7 (5)	5.3 (7.2)	8.8 (12)	8.8 (12)	14.7 (20)
250/6*	3.3 (4.5)	5.5 (7.5)	7.9 (10.8)	13.2 (18)	13.2 (18)	22 (30)

Model	Maximum Torques					
	Maximum (87 PSI) (6 Bars)					
	lb.ft.(Nm)					
250/1	15.8 (21.3)	27.5 (37.3)	37.8 (51)	66 (89.4)	63 (85)	110 (149)
250/2*	31.3 (42.5)	53.25 (72.3)	75 (102)	127.8 (173.4)	125 (170)	213 (298)
250/4*	62.8 (85)	110 (149)	150.6 (204)	264 (357.6)	251 (340)	440 (596)
250/6*	94 (127.5)	164.8 (223.5)	225.6 (306)	395.4 (536.4)	376 (510)	659 (894)

\* For single actuator operation torques for 250/1 are applicable.

Model <sup>6</sup>	Speed <sup>4</sup> Max. RPM	Heat Capacity for Effective Cooling Speeds							Inertia Rotating Parts lb.ft. <sup>2</sup> (kgm <sup>2</sup> )	Weight		
		Continuous Duty** HP(kW) <sup>5</sup>								Total	Rotating	
		50 RPM	100 RPM	200 RPM	300 RPM	400 RPM	500 RPM	600 RPM				
		<b>Without Fan</b>										
250/1	2250	1.34 (1.0)	1.61 (1.2)	2.14 (1.6)	2.68 (2.0)	3.08 (2.3)	3.49 (2.6)	3.62 (2.7)	1.424 (0.060)	27.337 (12.4)	19.180 (8.7)	
250/2	2250									29.101 (13.2)		
250/4	2250	<b>With Electric Cooling Fan, 150 mm dia.</b>										38.801 (17.6)
250/6	2250	4.56 (3.4)	4.69 (3.5)	5.09 (3.8)	5.36 (4.0)	5.36 (4.0)	5.36 (4.0)	5.36 (4.0)		48.772 (22.1)		

\*\* For intermittent duty, consult the factory.

<sup>1</sup> Minimum torques were calculated using a multiplier of 0.6 for LC times Standard.

<sup>2</sup> LC - Low Coefficient based on 0.2 Coefficient of friction.

<sup>3</sup> Standard based on 0.35 Coefficient of friction.

<sup>4</sup> Max. speed is with standard brake disc. A high speed brake disc capable of 50% higher speed is also available. Heat Capacity reduced by 10% when high speed disc is used.

<sup>5</sup> Limit LC to 70% of heat capacity.

<sup>6</sup> When selecting number of actuators, use a limit of 3.35 HP per actuator pair (2.5 kW per Actuator pair) for duty w/o fan and 3.75 HP per Actuator pair (2.8 kW per Actuator pair) when fan cooled.

**Note:** Limit maximum operating temperatures of surfaces (rotor, friction pads, actuators, etc.) to 300°F or less. Temperatures above 300°F may cause damage and failure of components. Failure to do so will void warranty.

# Tension Brakes/Air Cooled

## ModEvo Tension Brakes

### ModEvo Model 300

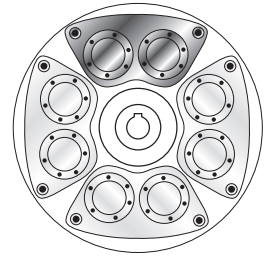

Model	Minimum Torques					
	Minimum (3 PSI) (0.2 Bars) <sup>1</sup>					
	lb.ft.(Nm)					
	LC <sup>2</sup>	Std <sup>3</sup>	LC <sup>2</sup>	Std <sup>3</sup>	LC <sup>2</sup>	Std <sup>3</sup>
	25% Actuators		60% Actuators		100 % Actuators	
300/1	0.7 (0.9)	1.1 (1.5)	1.6 (2.2)	2.6 (3.6)	2.6 (3.6)	5.2 (7)
300/2*	1.6 (2.1)	2.6 (3.5)	3.7 (5)	6.2 (8.4)	6.2 (8.4)	10.3 (14)
300/4*	3.1 (4.2)	5.2 (7)	7.4 (10.1)	12.4 (16.8)	12.4 (16.8)	20.6 (28)
300/6*	4.5 (6.3)	7.7 (10.5)	11.1 (15.1)	18.5 (25.2)	18.5 (25.2)	30.9 (42)
300/8*	6.2 (8.4)	10.3 (14)	14.9 (20.2)	24.8 (33.6)	24.8 (33.6)	41.3 (56)

Maximum Torques						
Maximum (87 PSI) (6 Bars)						
lb.ft.(Nm)						
300/1	19.8 (27)	34.9 (47.3)	47.4 (64.8)	83.6 (113.4)	79 (108)	139.4 (189)
300/2*	39.8 (54)	69.7 (94.5)	95.4 (129.6)	167.3 (226.8)	159 (216)	278.8 (378)
300/4*	79.5 (108)	139.4 (189)	190.8 (259.2)	334.6 (453.6)	318 (432)	557.6 (756)
300/6*	119.3 (162)	209.1 (283.5)	286.2 (388.8)	501.8 (680.4)	477 (648)	836.4 (1,134)
300/8*	159.3 (216)	278.8 (378)	382.2 (518.4)	669 (907.2)	637 (864)	1,115 (1,512)

\* For single actuator operation torques for 300/1 are applicable.

Model <sup>6</sup>	Speed <sup>4</sup> Max. RPM	Heat Capacity for Effective Cooling Speeds							Inertia Rotating Parts lb.ft. <sup>2</sup> (kbrn <sup>2</sup> )	Weight	
		Continuous Duty** HP(kW) <sup>5</sup>								Total	Rotating
		50 RPM	100 RPM	200 RPM	300 RPM	400 RPM	500 RPM	600 RPM			
300/1	1900	<b>Without Fan</b>							2.966 (0.125)	38.140 (17.3)	29.883 (13.6)
300/2	1900	2.41 (1.8)	2.68 (2.0)	3.35 (2.5)	4.02 (3.0)	4.56 (3.4)	5.09 (3.8)	5.63 (4.2)		39.904 (18.1)	
300/4	1900	<b>With Electric Cooling Fan, 150 mm dia.</b>								49.604 (22.5)	
300/6	1900	6.30 (4.7)	6.70 (5.0)	6.70 (5.0)	6.70 (5.0)	7.37 (5.5)	8.04 (6.0)	8.04 (6.0)		59.525 (27.0)	
300/8	1900									69.446 (31.5)	

\*\* For intermittent duty, consult the factory.

<sup>1</sup> Minimum torques were calculated using a multiplier of 0.6 for LC times Standard.

<sup>2</sup> LC - Low Coefficient based on 0.2 Coefficient of friction.

<sup>3</sup> Standard based on 0.35 Coefficient of friction.

<sup>4</sup> Max. speed is with standard brake disc. A high speed brake disc capable of 50% higher speed is also available. Heat Capacity reduced by 10% when high speed disc is used.

<sup>5</sup> Limit LC to 70% of heat capacity.

<sup>6</sup> When selecting number of actuators, use a limit of 3.35 HP per actuator pair (2.5 kW per Actuator pair) for duty w/o fan and 3.75 HP per Actuator pair (2.8 kW per Actuator pair) when fan cooled.

**Note:** Limit maximum operating temperatures of surfaces (rotor, friction pads, actuators, etc.) to 300°F or less.

Temperatures above 300°F may cause damage and failure of components. Failure to do so will void warranty.

# Tension Brakes/Air Cooled

## ModEvo Tension Brakes

### ModEvo Model 350

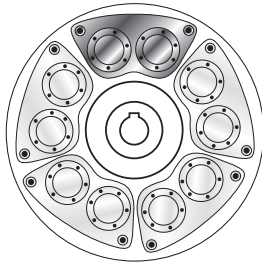

Model	Minimum Torques					
	Minimum (3 PSI) (0.2 Bars) <sup>1</sup>					
	lb.ft.(Nm)					
	LC <sup>2</sup>	Std <sup>3</sup>	LC <sup>2</sup>	Std <sup>3</sup>	LC <sup>2</sup>	Std <sup>3</sup>
	25% Actuators		60% Actuators		100 % Actuators	
350/1	0.9 (1.2)	1.5 (2)	2.1 (2.9)	3.5 (4.8)	3.5 (4.8)	5.9 (8)
350/2*	1.8 (2.4)	3.0 (4)	4.3 (5.8)	7.1 (9.6)	7.1 (9.6)	11.8 (16)
350/4*	3.6 (4.8)	5.9 (8)	8.5 (11.5)	14.2 (19.2)	14.2 (19.2)	23.6 (32)
350/6*	5.3 (7.2)	8.9 (12)	12.7 (17.3)	21.2 (28.8)	21.2 (28.8)	35.4 (48)
350/8*	7.1 (9.6)	11.8 (16)	17 (9.6)	28.3 (38.4)	28.3 (38.4)	47.2 (64)
350/10*	8.9 (12)	14.8 (20)	21.2 (28.8)	35.4 (48)	35.4 (48)	59.0 (80)

Model	Maximum Torques					
	Maximum (87 PSI) (6 Bars)					
	lb.ft.(Nm)					
350/1	24 (32.5)	42 (57)	57.55 (78)	101 (137)	95.9 (130)	168 (228)
350/2*	48 (65)	84.1 (114)	115.1 (156)	201.8 (273.6)	191.8 (260)	336.4 (456)
350/4*	95.9 (130)	168.2 (228)	230.2 (312)	403.6 (547.2)	383.6 (520)	672.7 (912)
350/6*	143.8 (195)	252.3 (342)	345.2 (468)	605.4 (820.8)	575.3 (780)	1009 (1,368)
350/8*	190.5 (260)	336.4 (456)	457.3 (624)	807.2 (1,094.4)	762.1 (1,040)	1,345.4 (1,824)
350/10*	239.7 (325)	420.4 (570)	575.3 (780)	1,009 (1,368)	9,58.9 (1,300)	1,681.7 (2,280)

\* For single actuator operation torques for 350/1 are applicable.

Model <sup>6</sup>	Speed <sup>4</sup> Max. RPM	Heat Capacity for Effective Cooling Speeds								Inertia Rotating Parts lb.ft. <sup>2</sup> (kbm <sup>2</sup> )	Weight	
		Continuous Duty** HP(kW) <sup>5</sup>									Total	Rotating
		50 RPM	100 RPM	200 RPM	300 RPM	400 RPM	500 RPM	600 RPM	lbs.(kg)			
350/2	1650	<b>Without Fan</b>								5.458 (0.230)	57.982 (24.8)	46.958 (20.3)
350/4	1650	3.22 (2.4)	3.49 (2.6)	4.69 (3.5)	5.36 (4.0)	6.17 (4.6)	7.37 (5.5)	8.04 (6.0)	69.005 (29.2)			
350/6	1650	<b>With Electric Cooling Fan, 150 mm dia.</b>									80.248 (33.7)	
350/8	1650	7.77 (5.8)	8.45 (6.3)	8.71 (6.5)	8.71 (6.5)	8.71 (6.5)	8.71 (6.5)	8.71 (6.5)	91.271 (38.2)			
350/10	1650										102.294 (42.7)	

\*\* For intermittent duty, consult the factory.

<sup>1</sup> Minimum torques were calculated using a multiplier of 0.6 for LC times Standard.

<sup>2</sup> LC - Low Coefficient based on 0.2 Coefficient of friction.

<sup>3</sup> Standard based on 0.35 Coefficient of friction.

<sup>4</sup> Max. speed is with standard brake disc. A high speed brake disc capable of 50% higher speed is also available. Heat Capacity reduced by 10% when high speed disc is used.

<sup>5</sup> Limit LC to 70% of heat capacity.

<sup>6</sup> When selecting number of actuators, use a limit of 3.35 HP per actuator pair (2.5 kW per Actuator pair) for duty w/o fan and 3.75 HP per Actuator pair (2.8 kW per Actuator pair) when fan cooled.

**Note:** Limit maximum operating temperatures of surfaces (rotor, friction pads, actuators, etc.) to 300°F or less.

Temperatures above 300°F may cause damage and failure of components. Failure to do so will void warranty.



# Tension Brakes/Air Cooled

## ModEvo Tension Brakes

### ModEvo Model 400

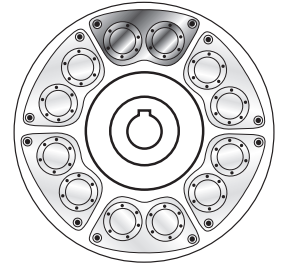

Model	Minimum Torques					
	Minimum (3 PSI) (0.2 Bars) <sup>1</sup> lb.ft.(Nm)					
	LC <sup>2</sup>	Std <sup>3</sup>	LC <sup>2</sup>	Std <sup>3</sup>	LC <sup>2</sup>	Std <sup>3</sup>
	25% Actuators		60% Actuators		100 % Actuators	
400/1	1.1 (1.5)	1.9 (2.5)	2.6 (3.6)	4.4 (6)	4.4 (6)	7.4 (10)
400/2*	2.2 (3)	3.7 (5)	5.3 (7.2)	8.9 (12)	8.9 (12)	14.8 (20)
400/4*	4.4 (6)	7.4 (10)	10.6 (14.4)	17.7 (24)	17.7 (24)	29.5 (40)
400/6*	6.7 (9)	11.1 (15)	16 (21.6)	26.6 (36)	26.6 (36)	44.3 (60)
400/8*	8.9 (12)	14.8 (20)	21.2 (28.8)	35.4 (48)	35.4 (48)	59.0 (80)
400/10*	11.1 (15)	18.5 (25)	26.6 (36)	44.3 (60)	44.3 (60)	73.8 (100)
400/12*	13.3 (18)	22.1 (30)	31.9 (43.2)	53.1 (72)	53.1 (72)	88.5 (120)

Maximum Torques						
Maximum (87 PSI) (6 Bars) lb.ft.(Nm)						
400/1	28.15 (38.15)	49.2 (66.7)	67.5 (91.5)	118 (160)	112.5 (152.5)	196.9 (267)
400/2*	56.3 (76.3)	98.3 (133.5)	135 (183)	236 (320.4)	225 (305)	393.9 (534)
400/4*	112.5 (152.5)	197 (267)	270 (366)	472.7 (640.8)	450 (610)	787.8 (1,068)
400/6*	168.7 (228.8)	295.4 (400.5)	404.9 (549)	708.9 (961.2)	674.9 (915)	1,181.9 (1,602)
400/8*	225 (305)	393.9 (534)	539.9 (732)	945.3 (1,281.6)	899.9 (1,220)	1,575.5 (2,136)
400/10*	281.2 (381.3)	492.4 (667.5)	674.9 (915)	1,181.6 (1,602)	1,124.8 (1,525)	1,969.4 (2,670)
400/12*	337.5 (457.5)	590.8 (801)	809.9 (1,098)	1,417.9 (1,922.4)	1,349.8 (1,830)	2,363.3 (3,204)

\* For single actuator operation torques for 400/1 are applicable.

Model <sup>6</sup>	Speed <sup>4</sup> Max. RPM	Heat Capacity for Effective Cooling Speeds							Inertia Rotating Parts lb.ft. <sup>2</sup> (kcm <sup>2</sup> )	Weight	
		Continuous Duty** HP(kW) <sup>5</sup>								Total	Rotating
		50 RPM	100 RPM	200 RPM	300 RPM	400 RPM	500 RPM	600 RPM			
400/2	1450	<b>Without Fan</b> 3.62   4.29   6.03   6.70   7.64   8.71   9.38 (2.7)   (3.2)   (4.5)   (5.0)   (5.7)   (6.5)   (7.0)							9.492 (0.400)	69.005 (31.3)	61.509 (26.8)
400/4	1450									78.705 (35.7)	
400/6	1450	88.626 (40.2)									
400/8	1450	98.547 (44.7)									
400/10	1450	108.467 (49.2)									
400/12	1450	118.168 (53.6)									
		<b>With Electric Cooling Fan, 150 mm dia.</b> 8.18   8.98   9.38   10.05   10.72   10.72   10.72 (6.1)   (6.7)   (7.0)   (7.5)   (8.0)   (8.0)   (8.0)									

\*\*For intermittent duty and thermal ratings using 200 mm fan, consult the factory.

<sup>1</sup> Minimum torques were calculated using a multiplier of 0.6 for LC times Standard.

<sup>2</sup> LC - Low Coefficient based on 0.2 Coefficient of friction.

<sup>3</sup> Standard based on 0.35 Coefficient of friction.

<sup>4</sup> Max. speed is with standard brake disc. A high speed brake disc capable of 50% higher speed is also available. Heat Capacity reduced by 10% when high speed disc is used.

<sup>5</sup> Limit LC to 70% of heat capacity.

<sup>6</sup> When selecting number of actuators, use a limit of 3.35 HP per actuator pair (2.5 kW per Actuator pair) for duty w/o fan and 3.75 HP per Actuator pair (2.8 kW per Actuator pair) when fan cooled.

**Note:** Limit maximum operating temperatures of surfaces (rotor, friction pads, actuators, etc.) to 300°F or less.

Temperatures above 300°F may cause damage and failure of components. Failure to do so will void warranty.

# Tension Brakes/Air Cooled

## ModEvo Tension Brakes

### ModEvo Model 450

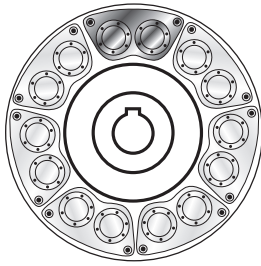

Model	Minimum Torques					
	Minimum (3 PSI) (0.2 Bars) <sup>1</sup> lb.ft.(Nm)					
	LC <sup>2</sup>	Std <sup>3</sup>	LC <sup>2</sup>	Std <sup>3</sup>	LC <sup>2</sup>	Std <sup>3</sup>
	25% Actuators		60% Actuators		100 % Actuators	
450/1	1.2 (1.7)	2.0 (2.8)	2.9 (4.0)	4.9 (6.6)	4.9 (6.6)	8.1 (11)
450/2*	2.3 (3.2)	3.9 (5.3)	5.6 (7.6)	9.3 (12.6)	9.3 (12.6)	15.5 (21)
450/4*	4.7 (6.3)	7.8 (10.5)	11.2 (15.1)	18.6 (25.2)	18.6 (25.2)	31.0 (42)
450/6*	7 (9.5)	11.6 (37.8)	16.7 (22.7)	27.9 (37.8)	27.9 (37.8)	46.5 (63)
450/8*	9.3 (12.6)	15.7 (15.5)	22.3 (30.2)	37.7 (50.4)	37.2 (50.4)	62.0 (84)
450/10*	11.6 (15.8)	19.4 (26.3)	27.9 (37.8)	46.5 (63)	46.5 (63)	77.5 (105)
450/12*	13.9 (18.9)	23.2 (31.5)	33.4 (45.4)	55.7 (75.6)	55.7 (75.6)	92.9 (126)
450/14*	13.6 (22.1)	27.1 (27.1)	39 (52.9)	65 (88.2)	65 (88.2)	108.4 (147)

	Maximum Torques					
	Maximum (87 PSI) (6 Bars) lb.ft.(Nm)					
450/1	32.45 (44)	56.7 (77)	77.9 (105.6)	136.3 (189.8)	129.8 (176)	227.2 (308)
450/2*	64.9 (88)	113.6 (154)	155.8 (211.2)	272.6 (369.6)	259.6 (352)	454.4 (616)
450/4*	129.8 (176)	227.2 (308)	311.6 (422.4)	545.2 (739.2)	519.3 (704)	908.7 (1,232)
450/6*	194.7 (264)	340.8 (462)	467.3 (633.6)	817.9 (1,108.8)	778.9 (1,056)	1,363.1 (1,848)
450/8*	259.6 (352)	454.4 (616)	623.1 (844.8)	1,090.4 (1,478.4)	1,038.5 (1,408)	1,817.4 (2,464)
450/10*	324.6 (440)	568 (770)	778.9 (1,056)	1,363.1 (1,848)	1,298.2 (1,760)	2,271.8 (3,080)
450/12*	389.5 (528)	681.6 (924)	934.7 (1,267.2)	1,635.7 (2,217.6)	1,557.8 (2,112)	2,726.2 (3,696)
450/14*	454.4 (616)	795.1 (1,078)	1,090.4 (1,478.4)	1,908.3 (2,587.2)	1,817.4 (2,464)	3,180.5 (4,312)

\* For single actuator operation torques for 450/1 are applicable.

Model <sup>6</sup>	Speed <sup>4</sup> Max. RPM	Heat Capacity for Effective Cooling Speeds							Inertia Rotating Parts lb.ft. <sup>2</sup> (kgm <sup>2</sup> )	Weight	
		Continuous Duty** HP(kW) <sup>5</sup>								Total	Rotating
		50 RPM	100 RPM	200 RPM	300 RPM	400 RPM	500 RPM	600 RPM			
450/2	1250								14.475 (0.610)	82.673 (37.5)	72.752 (33.0)
450/4	1250	<b>Without Fan</b>								92.374 (41.9)	
450/6	1250	3.89 (2.9)	4.83 (3.6)	6.84 (5.1)	7.91 (5.9)	8.71 (6.5)	10.32 (7.7)	11.13 (8.3)		102.294 (46.4)	
450/8	1250	<b>With Electric Cooling Fan, 150 mm dia.</b>								112.215 (50.9)	
450/10	1250	8.85 (6.6)	9.12 (6.8)	9.38 (7.0)	9.65 (7.2)	10.72 (8.0)	11.66 (8.7)	12.47 (9.3)		122.136 (55.4)	
450/12	1250									131.836 (59.8)	
450/14	1250									141.757 (64.3)	

\*\*For intermittent duty and thermal ratings using 200 mm or 250 mm fan, consult the factory.

<sup>1</sup> Minimum torques were calculated using a multiplier of 0.6 for LC times Standard.

<sup>2</sup> LC - Low Coefficient based on 0.2 Coefficient of friction.

<sup>3</sup> Standard based on 0.35 Coefficient of friction.

<sup>4</sup> Max. speed is with standard brake disc. A high speed brake disc capable of 50% higher speed is also available. Heat Capacity reduced by 10% when high speed disc is used.

<sup>5</sup> Limit LC to 70% of heat capacity.

<sup>6</sup> When selecting number of actuators, use a limit of 3.35 HP per actuator pair (2.5 kW per Actuator pair) for duty w/o fan and 3.75 HP per Actuator pair (2.8 kW per Actuator pair) when fan cooled.

**Note:** Limit maximum operating temperatures of surfaces (rotor, friction pads, actuators, etc.) to 300°F or less. Temperatures above 300°F may cause damage and failure of components. Failure to do so will void warranty.



# Tension Brakes/Air Cooled

## ModEvo Tension Brakes

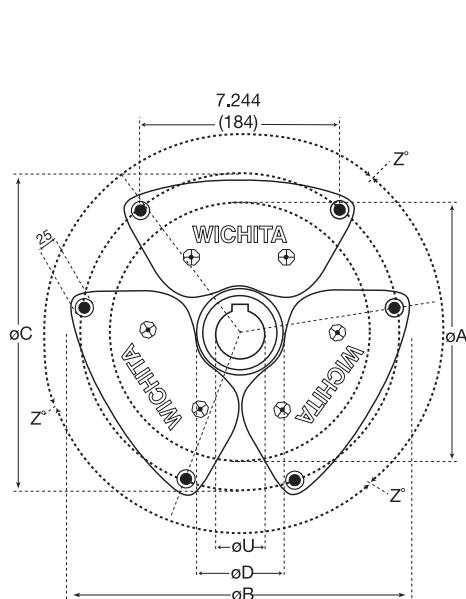

Front View

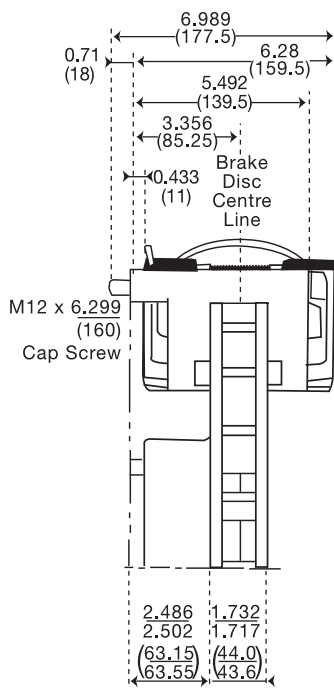

Side View

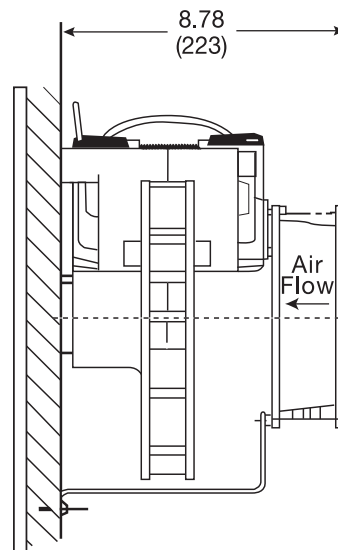

Side View With Fan

### Dimensions: inches (mm)

Size	250	300	350	400	450
$\phi A$ - Disc Size	9.843 (250)	11.811 (300)	13.78 (350)	15.748 (400)	17.717 (450)
$\phi B$ - Overall	12.756 (324)	14.528 (369)	16.339 (415)	18.149 (461)	20.000 (508)
$\phi C$ - Bolt P.C.D	11.752 (298.5)	13.524 (343.5)	15.315 (389)	17.146 (435.5)	18.996 (482.5)
$\phi D$ - Clearance Diameter	3.543 (90)	5.512 (140)	7.480 (190)	9.449 (240)	11.417 (290)
U - As Cast Bore	0.984 (25)	0.984 (25)	0.984 (25)	0.984 (25)	0.984 (25)
Maximum Bore	2.165 (55)	3.110 (79)	4.606 (117)	5.354 (136)	6.063 (154)
Z" - Angular Position	120°	90°	72°	60°	51.4°
Maximum Number of Brake Modules	3	4	5	6	7
Wichita Generic Drawing Number	73125-000	73130-000	73141-000	73141-000	73145-000
Hose Length/Module 15667-020 W4 6977	39.37 (1,000)	47.25 (1,200)	55.12 (1,400)	63.00 (1,600)	70.87 (1,800)

# Spring-Set Motor Brakes

- Failsafe protection — spring-set
- Long wear life
- Quick, smooth stopping

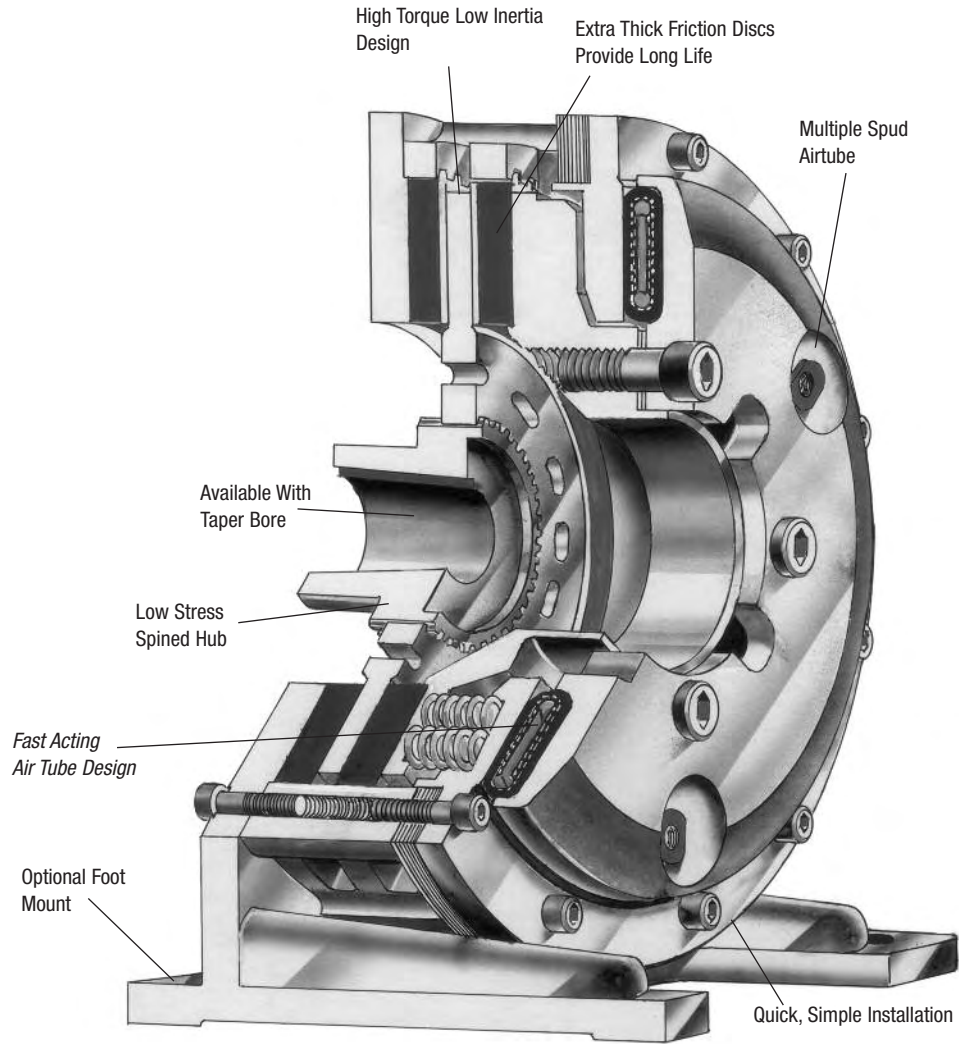

Wichita spring-set, air release Motor Brakes are ideal for failsafe protection of process equipment. Available in foot mounted and C-face options, this improved design has thicker friction discs for longer wear life. The fast acting Spring-Set actuation assures quick, smooth stops.

# Spring-Set Motor Brakes

## Specifications

Model Size ATD—	Slip Torque lb.in. .3 CF* Minimum Air-Tube Pressure PSI For Released Brake			*Do Not Exceed 90% Of Slip Torque Ratings — Maximum Horsepower Per 100 RPM Release Pressure - PSI							
	60	75	90	60 PSI Duty				75 PSI Duty			
				A	B	C	D	A	B	C	D
106 MB	2,225	2,900	3,700	3	2.3	1.2	.6	4	3	1.5	.8
206 MB	4,300	5,600	7,200	6	4.4	2.3	1.1	8	5.7	3	1.5
108 MB	3,700	4,800	6,200	5.3	3.8	2	1	7	5	2.6	1.3
208 MB	7,100	9,100	12,000	10	7.3	3.8	2	13	9.3	5	2.5
111 MB	8,200	10,500	11,600	11.7	8.4	4.4	2.2	15	10.7	5.7	2.8
211 MB	15,600	20,000	22,200	22	16	8.4	4.2	28.6	20.5	11	5.4
114 MB	14,500	18,600	24,700	20	15	8	4	26.6	19	10	5
214 MB	27,600	35,400	46,300	39	28	15	7.5	50	36	19	9.5
118 MB	31,400	40,400	51,600	45	32	17	8.5	58	41	22	11
218 MB	60,000	77,000	100,000	86	61	32	16	110	79	41	21
124H MB	75,500	86,600	—	108	77	41	20	158	114	60	30
224H MB	137,000	161,200	—	196	140	74	37	308	222	117	58

\* Max. recommended air pressure – 130 PSI

Model Size ATD—	90 PSI Duty				Max. Bore Rect. Key Inches	Total Wt. lbs.	Hub & CP Wt. lbs.	Hub & CP WR <sup>2</sup> lb.ft. <sup>2</sup>	Effec. WR <sup>†</sup> lbs.
	A	B	C	D					
106 MB	5	3.8	2	1	2	36.5	6.40	.24	14.0
206 MB	10	7.4	3.9	2	2	49.5	12.17	.46	18.34
108 MB	9	6.3	3.3	1.6	2-3/8	63.23	10.0	.55	26.78
208 MB	17	12.3	6.5	3.2	2-3/8	81.5	16.0	.72	32.03
111 MB	16.6	12	6.3	3.1	2-5/8	96.96	15.0	1.35	40.75
211 MB	37	26	14	7	2-5/8	136.0	30.0	2.60	59.05
114 MB	35	25	13	6.7	4-1/8	157.6	38	5.6	72.3
214 MB	66	47	25	12.5	4-1/8	209.6	65	11	95.3
118 MB	74	53	28	14	5-1/4	322	71	14.5	168
218 MB	143	102	54	27	5-1/4	444	113	27.6	215
124H MB	183	131	69	34	7	690	131	50	377
224H MB	346	248	131	65	7	874	260	101	482

† Weight of internal clutch parts for use in calculating clutch engagement time.





# Spring-Set Motor Brakes

## C-Face Motor Brakes

- No adjustment
- No lubrication
- Low inertia design
- Rugged, dependable design

C-face adaptors are available in standard NEMA T and U frame designs. Custom adaptors are available for your specific motor design. Dimensions G, H, I, J and number of holes need to be provided to Wichita Engineering before final design is completed.

When using Wichita C-Face Motor Brakes in a high cycling application, brake thermal capacity and motor thermal capacity need to be carefully matched. The motor information chart lists the specific Wichita part numbers for the proper adapter plate and brake for C-Faced Motors up to 200 HP.

Contact Wichita Application Engineering for assistance.

### Motor Information

Frame	Max. HP at Std. RPM	Full Load Motor Torque in.lb.	Steel Adapter Plate	Model Size ATD-
C210	40 / 2500	1,008	4-309-075-011-3	7-108-100-113-0 108 MB
C250	60 / 1750	2,161	4-309-075-005-3	7-108-100-113-0 108 MB
C280	100 / 1750	3,601	4-281-075-015-3	7-111-100-112-0 111 MB
C320	150 / 1750	5,402	4-281-075-016-3	7-111-100-112-0 111 MB
C360	200 / 1750	7,202	4-271-075-007-3	7-114-100-113-0 114 MB

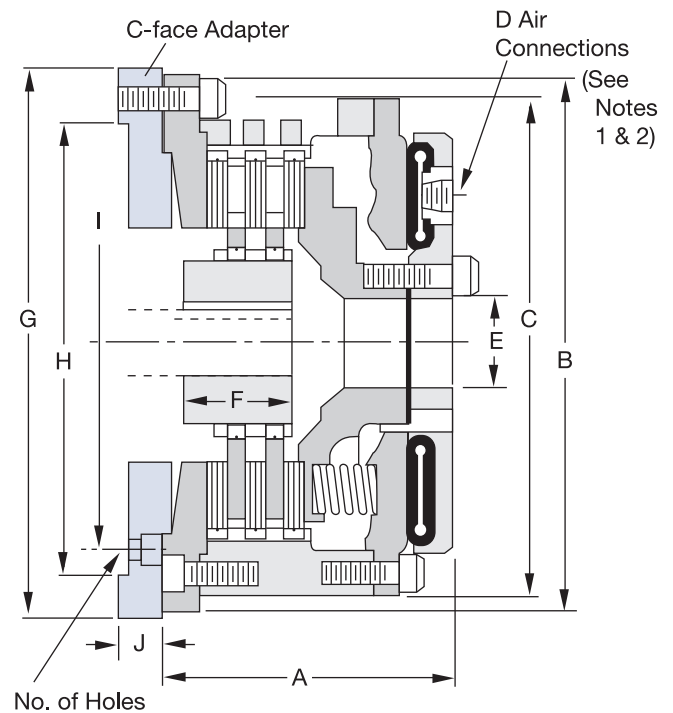

### Dimensions: inches (Consult factory for drawing before final layout.)

Model Size ATD-	A	B	C	D	No. of Spuds	E	F
106 MB	5.44	8.75	8.81	1/4" NPT	2	2.00	2.00
206 MB	6.75	8.75	8.81	1/4" NPT	2	2.00	3.25
108 MB	5.82	12.12	11.13	1/2" NPT	2	2.13	1.50
208 MB	7.00	12.12	11.13	1/2" NPT	2	2.13	2.87
111 MB	6.38	16.00	14.75	1/2" NPT	2	3.02	2.00
211 MB	7.75	16.00	14.75	1/2" NPT	2	3.02	3.75
114 MB	7.75	18.75	17.50	1/2" NPT	2	3.88	2.25
214 MB	9.69	18.75	17.50	1/2" NPT	2	3.88	4.25
118 MB	9.01	23.25	22.00	1/2" NPT	3	4.75	2.75
218 MB	10.69	23.25	22.00	1/2" NPT	3	4.75	4.75
124H MB	9.26	30.00	29.00	1/2" NPT	3	8.25	3.13
224H MB	11.94	30.00	29.00	1/2" NPT	3	8.25	5.13

Wichita motor brakes typically produce more torque than is usually necessary. Contact Wichita engineering for help in selecting the number of springs to produce the proper deceleration for your application.

**Note:** For mounting, use socket head capscrews conforming to the ASTM-574-97a.

### Notes:

1. Quick Release Valves, see page 121.
2. Air Hose Kits, see page 120.

# Spring-Set Motor Brakes

## Foot Mounted Motor Brakes

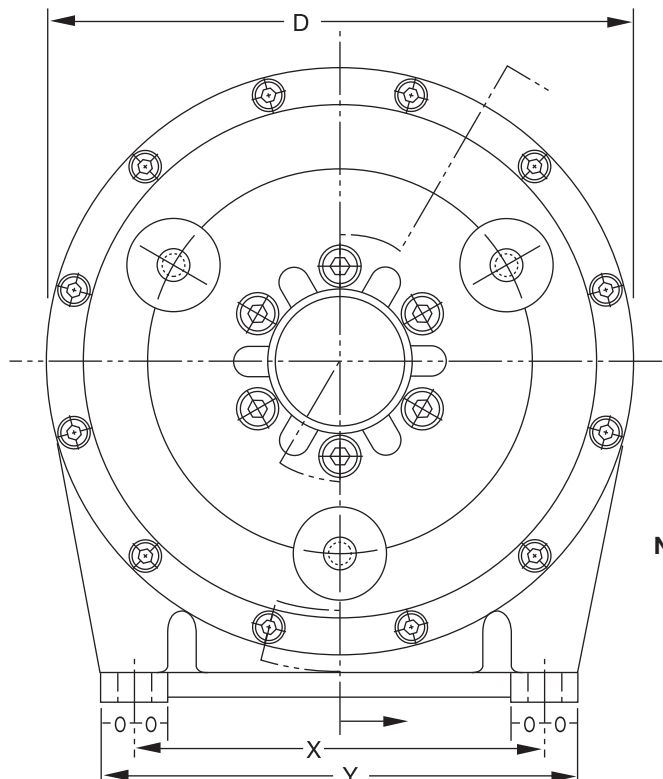
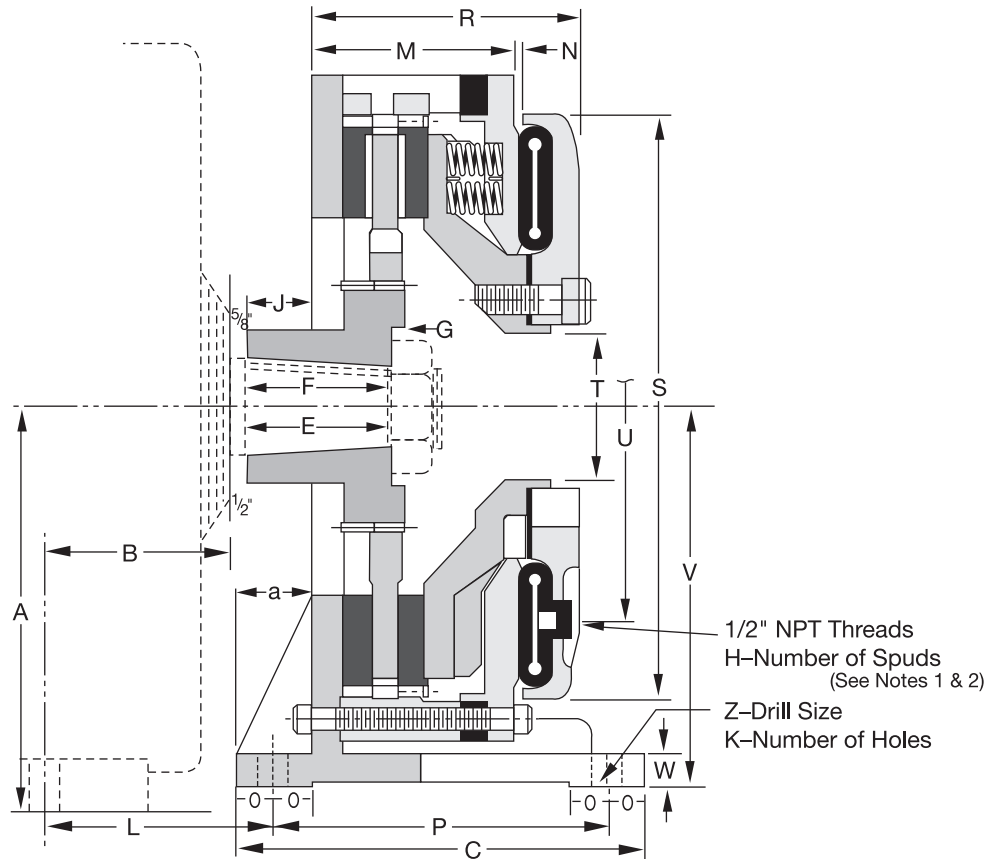

**Notes:**

1. Quick Release Valves, see page 121.
2. Air Hose Kits, see page 120.



# Spring-Set Motor Brakes

**Dimensions: inches** (Consult factory for drawing before final layout.)

Motor Frame	Model Size ATD-	A	B	C	D	E	F ±.015	G	H	J	K	L	M
602	108 MB 208 MB	7.625	3.75	7.50	11.125	2.75	2.875	.75 1.625	2	1.75	4	5.375	4.75 .313
603	111 MB 211 MB	8.50	4.50	8	14.75	3.25	3.312	.375 1.375	2	1.625	4	6.125	4.563 5.563
604	111 MB 211 MB	9	5	8	14.75	3.25	3.312	.375 1.375	2	1.625	4	6.625	4.563 5.563
606	114 MB 214 MB	10	5	11	17.50	4	4.125	.50 1.875	2	1.125	4	6	5.438 6.813
608	114 MB 214 MB	11.25	5.125	11	17.5	4.50	4.625	.50 1.875	2	1.50	4	6.50	5.438 6.813
610	118 MB 218 MB	12.25	5.75	13.50	22	4.50	4.625	.50 2.188	3	3.125	4	8.25	8.094 9.781
612	118 MB 218 MB	13.375	6.25	13.50	22	4.75	4.875	.50 2.188	3	3.125	4	8.75	8.094 9.781
614	124H MB 224H MB	14.75	7.25	23.25	29	4.75	4.875	.50 2.25	3	2.125	4	10.125	7.188 8.75
616	124H MB 224H MB	16	8.50	23.25	29	5.25	5.375	.50 2.25	3	2.75	4	11.375	7.188 8.75
618	124H MB 224H MB	17.75	8	23.25	29	5.75	5.875	.50 2.25	3	2.25	4	10.875	7.188 8.75

Motor Frame	Model Size ATD-	N	O	P	R	S	T	U	V	W	X	Y	Z	a
602	108 MB 208 MB	.313	.875	5.75	5.875 6.75	9.375	1.95	6.625	7	.75	3.25	8.25	.688	1.625
603	111 MB 211 MB	.313	.875	6.25	6 7	11.938	3	8.50	8.375	.75	4	9.75	.688	1.50
604	111 MB 211 MB	.313	.875	6.25	6 7	11.938	3	8.50	8.375	.75	4	9.75	.688	1.50
606	114 MB 214 MB	.563	1	9	7.50 8.875	14.375	3.88	10.75	9.875	1	5.75	13.50	.813	1.75
608	114 MB 214 MB	.563	1	9	7.50 8.875	14.375	3.88	10.75	9.875	1	5.75	13.50	.813	1.75
610	118 MB 218 MB	.375	1.25	11	10.50 12.188	19.375	4.875	14.188	12.50	1	7.75	18	.938	2.50
612	118 MB 218 MB	.375	1.25	11	10.50 12.188	19.375	4.875	14.188	12.50	1	7.75	18	.938	2.50
614	124H MB 224H MB	.375	1.625	19	9.438 11.125	27	8.25	21	20.75	2	15	33.25	1.563	2.625
616	124H MB 224H MB	.375	1.625	19	9.438 11.125	27	8.25	21	20.75	2	15	33.25	1.563	2.625
618	124H MB 224H MB	.375	1.625	19	9.438 11.125	27	8.25	21	20.75	2	15	33.25	1.563	2.625

Wichita motor brakes typically produce more torque than is usually necessary.

Contact Wichita Engineering for help in selecting the number of springs to produce the proper deceleration for your application.

**Note:** For mounting, use socket head capscrews conforming to the ASTM-574-97a.

# Spring-Set Motor Brakes

## Air Hose Kits

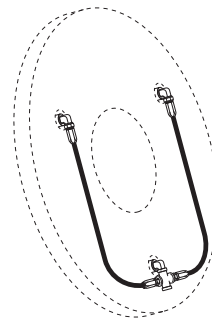
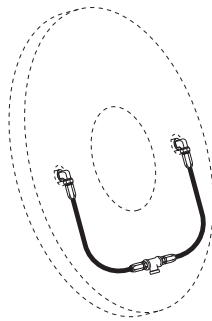
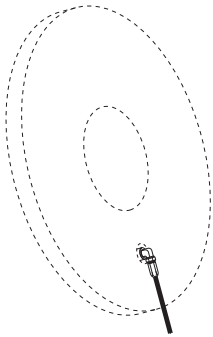

Model	Part Number
8"	8-908-912-100-5 8-908-924-100-5 QRV

Model	Part Number
6"	8-906-912-200-4 8-906-931-201-5 QRV
8"	8-908-913-200-5 8-908-931-200-5
11"	8-911-913-200-5 8-911-931-200-5 QRV
14"	8-914-913-200-5 8-914-921-200-5 QRV
16"	8-916-913-200-5 8-916-921-200-5 QRV

Model	Part Number
18"	8-918-912-200-5 8-918-931-200-5 QRV
21"	8-921-913-200-5 8-921-931-200-5 QRV
24"	8-924-913-200-5 8-924-931-200-5 QRV
27"	8-927-913-200-5 8-927-921-200-5 QRV

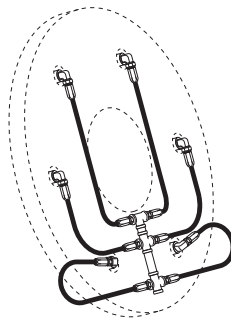
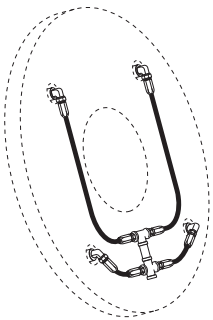

Air hose kits contain all necessary parts (fittings, hoses and extensions) to completely plumb the brake air system.

Optional Quick Release Valves can replace elbows on most units (see page 121).

Model	Part Number
30"	8-930-913-400-5 8-930-931-400-5 QRV
36"	8-936-913-400-6 8-936-931-400-6 QRV
42"	8-942-913-400-6 8-924-931-400-6 QRV
48"	8-948-912-400-6 8-948-923-400-6 QRV

Model	Part Number
60"	8-960-912-500-5 8-960-923-400-6 QRV



# Spring-Set Motor Brakes

## Quick Release Valve

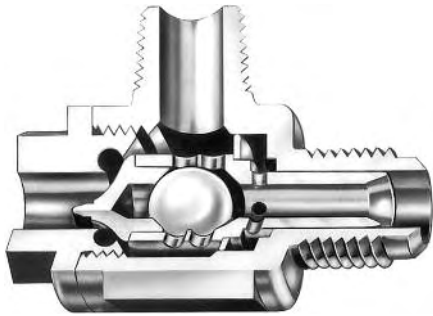

8-263-610-011-1      7/8" - 14 Thread  
 8-263-610-021-1      1/2" NPT

The Wichita Springless Quick Release Valve discharges twice as fast as any other valve tested in our laboratory and is four to five times faster than some common makes of valves.

This valve will close and seal with less than 20 lbs. pressure. Most others require 25 to 30 lbs. to definitely seal. In actual tests, the Wichita Valve made many hundreds of thousands of engagements and disengagements before the slightest leak occurred, or any parts needed replacement. Other valves which were tested required major replacement in fewer than 20,000 cycles.

### Quality Material

- Body and Cap: High strength aluminum alloy
- Stem: Molded nylon
- Check Valve: Nylon ball
- "O" Ring: Neoprene

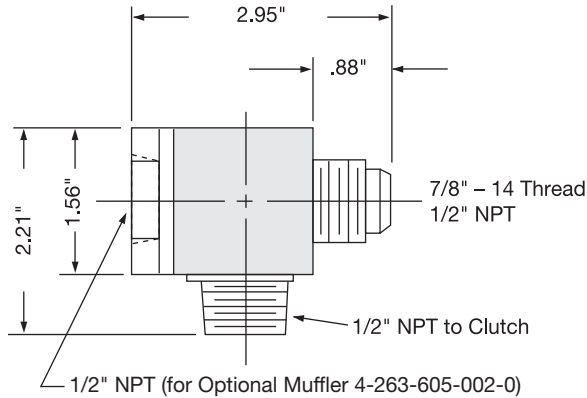

Standard thread arrangement of 1/2" size. 1/2" pipe thread on the tube connection and choice of 1/2" pipe thread, or standard 7/8-14NF thread for flared fitting thread on inlet connection. (Fits standard No. 10 high-pressure hose fitting.)

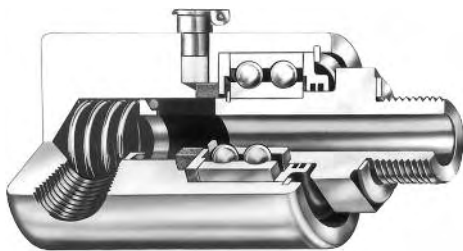

The Wichita Roto-coupling is a device to connect, or couple, a non-rotating air, gas, or fluid line to a rotating shaft.

### Roto-couplings

- Long life, no maintenance.
- Felt seal eliminates bearing contamination.
- Fast, easy installation.

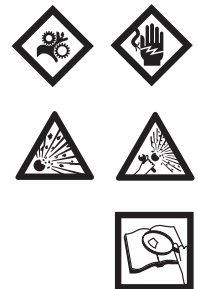
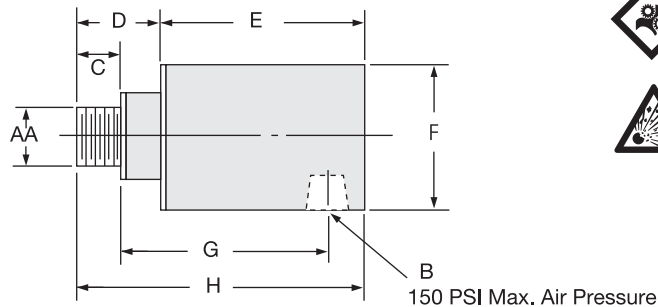

### Dimensions: inches (mm)

Wichita Part No.	AA	B	C	D	E	F	G	H	Max. RPM
8-240-701-003-1	5/8-18NF	1/4" NPT	.40	1.046	2.250	1.500	2.13	3.297	3500
8-240-705-001-1	1"-14 NF	1/2" NPT	.75	1.250	3.188	2.500	3.00	4.438	3500
8-240-708-001-1	1"-14 NF	3/4" NPT	.75	1.313	4.688	2.875	3.69	5.440	3500
8-240-710-002-1	1-1/2"-12 NF	1" NPT	1.13	1.937	4.875	3.250	3.44	6.812	2500
8-240-712-001-1	2"-12 NF	1-1/2" NPT	1.13	2.813	5.250	4.250	5.38	8.062	2500
8-240-714-001-3	2" NPT	2" NPT	1.50	3.000	7.062	4.625	7.00	10.062	1000
8-240-716-000-3	2-1/2" NPT	2-1/2" NPT	1.88	3.250	9.375	7.000	7.75	12.625	750

# Standard Vent Clutches

---

## Coupling Clutches

The Wichita Standard Vent Combination Clutch-Coupling is designed for reliable in-line power transmission. The simple air-tube design, with small air volume, speeds engagement and disengagement. It is unaffected by centrifugal force and has no self-energization like drum clutch designs. Ideally suited for large inertia loads where smooth controlled starts are needed.

See pages 131 thru 135.

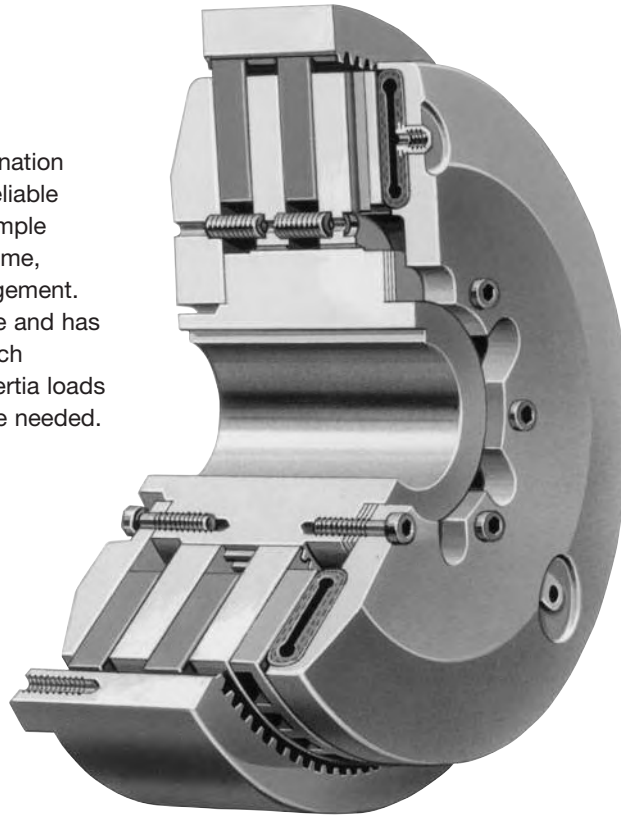

## Grinding Mill Clutches

Wichita Grinding Mill Clutches are specially designed to provide quick, smooth starts with limited current surge for heavy duty grinding mills. The clutch is adaptable to remote control allowing centralized operation through simple air or electric circuits.

See pages 136 thru 143.

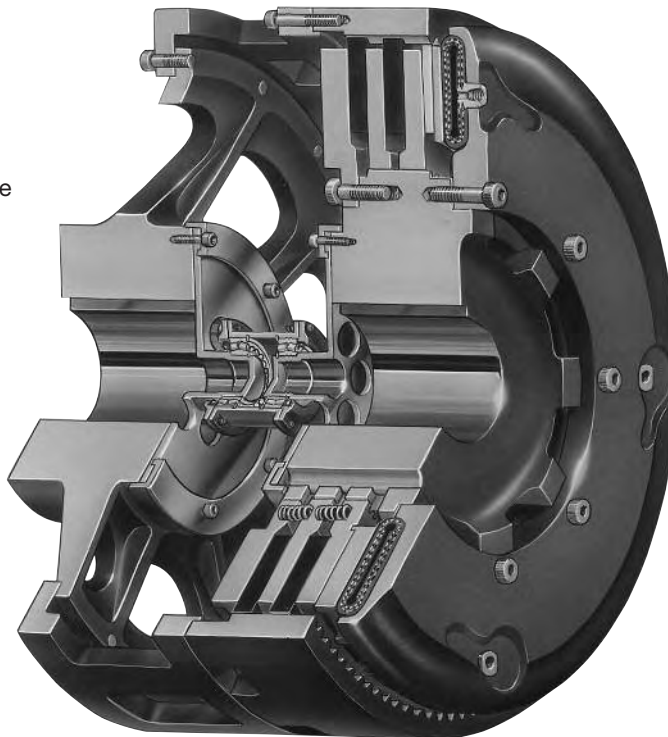

# Standard Vent Clutches

## Typical Applications

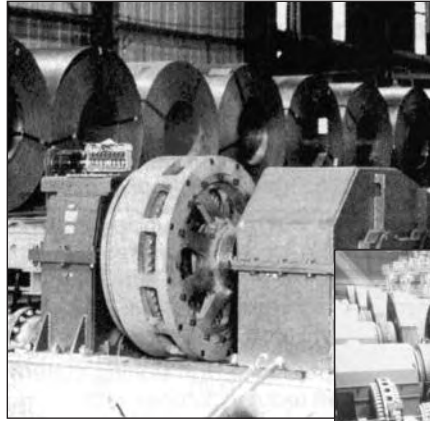

Wichita ATD-342 Clutches allow smooth acceleration of coil transporter.

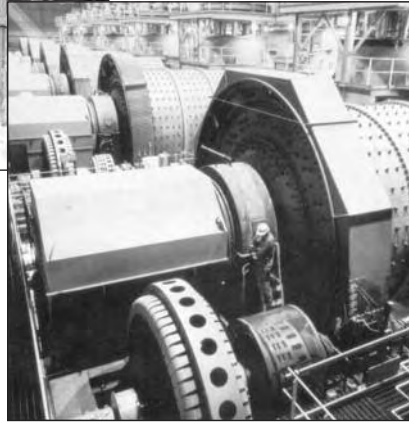

Reliable, trouble-free Wichita Standard Vent Clutches handle maximum loads on drilling rigs.

Wichita Grinding Mill Clutches provide shock-free start-up of large inertia loads.

### Application Guidelines

Clutch selection is made by knowing the application horsepower/100 RPM, the available air pressure, required torque and

the clutch heat horsepower. The Requirements Table (Chart A) gives application factors ranging from light duty (the A group) to extra heavy duty (the D group).

### Chart A

Field of Application	Group A	Group B	Group C	Group D
Pumps		Centrifugal compressors	Reciprocating compressors over 2 cylinders, centrifugal fans & blowers	Reciprocating compressors one or two cylinders
Agitators	Liquid	Semi-solid	Solids	
Brick manufacturing			Brick press, extruder, pug mill	
Can & bottling machine		Bottle-can feeders, filling, mixers		
Engine driven equipment			Crane, hoist, engine	Crowd
Grinding mills			Ball-rod-sag-pebble	Crushers, shakers
Lumber processing		Yarder	Carriages, conveyers	Chipper, logger
Marine		Propulsion clutch CP wheel	Shaft brakes, propulsion reversing type, anchor winch	
Bulk material handling	Conveyors evenly loaded, line shaft evenly loaded	Feeders	Elevators	
Metal production & metalforming		Coilers, slitters, press brake, non-g geared press, geared press	Draw bench, rolling mill, shear, back geared press, deep draw press, transfer press, toggle press	Hammer mill, forming press, forging press, header press, knuckle press
Paper industry dryer sections & calenders consult factory			Fourdrinier to 500 FPM, paper mill plane & smoothing press	Fourdrinier to 1800 RPM press selections, calenders & dryers
Petroleum production		Drilling & service rig master clutches, compound clutches, rotary, drum		Mud pumps, PTO clutches
Rubber manufacturing	Transfer machines evenly loaded		Banberry mixer, drum mixer, extruder, calender	Centrifuge



# Standard Vent Clutches

## Coupling and Grinding Mill Clutches

### Selection

Clutch sizes are affected by the following variables:

1. Machines that operate under smooth loads require smaller clutches. These machines are driven by either multi-cylinder high speed engines or electric motors with reduced starting current.
2. Drives that require high starting current motors will require clutches with sufficient torque to prevent excessive slipping while starting.
3. Starting torque may be high, which requires fast clutch response time to transmit the required torque or extended clutch slip time to protect the prime mover.
4. Starting torques may be very low compared to the normal torque, which may result in the clutch not being fully pressurized prior to the time of torque requirement. This will cause the clutch to over-heat from slippage. Clutch inflation time in this instance is very important.
5. Clutches on most machines are designed to slip prior to damage from shockloads. As a result, the clutch may require periodic maintenance; therefore the clutch should be located, for easy access, in the power train. Clutches should also be located for maximum cooling air. In instances where this is not possible, forced air cooling may be necessary for extended clutch life.
6. Safe operating speeds for clutches should be maintained in design. The following material specifications are recommended for safe operation. The maximum speeds shown are safe operating speeds based upon years of Wichita experience.

Maximum Clutch Contact Velocity FPM	Material
6,000 (Recommended upper limit for slip)	cast iron
9,000	ductile iron
12,000	steel

These velocities are measured at the nominal outside diameter of the clutch plates.

### Selection Example

To properly select a clutch for your application, the following information is required:

1. Application horsepower
2. Required air pressure
3. Required torque
4. Clutch heat horsepower
5. Shaft diameter

Chart A (page 123) gives application requirements ranging from light duty (the A group) to extra heavy duty (the D group). This chart will give the initial selection which is then compared with the selection made using the Clutch Heat Horsepower Chart B and the Clutch area (see "lining area" column) in the Specification Table (Chart C, page 125-126).

#### Machine required:

Rock crusher (Grinding mill)  
(Group D duty requirement)

WR<sup>2</sup> .....1,000 lb.ft.<sup>2</sup>  
 RPM .....1,800  
 Clutch Slip Time .....6 sec.  
 HP .....325 (diesel 8 cylinder)  
 Available air pressure .....120 PSI

Clutch must slip while bringing equipment up to speed.

### Chart B

Clutch heat horsepower absorption rate\*

Slip Time Seconds	Heat Input	
	ft.lb. in. <sup>2</sup>	HP in. <sup>2</sup>
0 to 1	380	.7
2	617	.56
3	820	.5
4	1,000	.45
5	1,175	.43
6	1,330	.4
7	1,485	.38
8	1,630	.37
9	1,770	.36
10	1,900	.34

\* This chart is for use when clutch is at ambient temperature of 120° F max.

# Standard Vent Clutches

## Coupling and Grinding Mill Clutches

### Calculations

$$\text{Engine torque} = \frac{(\text{HP}) (63,000)}{\text{RPM}} = \frac{(325) (63,000)}{1800}$$

$$\text{Engine torque} = 11,375 \text{ lb.in.}$$

Clutch torque required while slipping:

$$\text{Clutch torque} = \frac{(WR^2) (\text{RPM}) (\pi) \text{ lb.in.}}{(g) (t_s) (2.5)}$$

W = Weight to be accelerated lb.

R = Radius of gyration ft.<sup>2</sup>

g = Acceleration of gravity ft./sec.<sup>2</sup>

t<sub>s</sub> = Time of slip, in seconds

T<sub>c</sub> = Clutch torque = 11,707 lb.in.

Clutch heat HP is 1/2 of the total area in the diagram.

$$\text{Clutch heat HP} = \frac{(T_c) (\text{input RPM})}{63,000} (1/2)$$

$$\begin{aligned} \text{Clutch heat HP} &= \frac{(11,375) (1,800)}{63,000} (1/2) \\ &= 162.5 \text{ HP} \end{aligned}$$

From Clutch Heat Horsepower (Chart B) for a 6 second start:

$$\text{HP} / \text{in.}^2 = .4$$

$$\text{Area required} = \frac{162.5}{.4} = 406 \text{ in.}^2$$

To properly select a clutch for this rock crusher application, the following information is required:

1. Application horsepower
2. Required air pressure
3. Required torque
4. Clutch heat horsepower
5. Shaft diameter

The Specification Table on pages 126-127 gives application factors ranging from light duty (the A group) to extra heavy duty (the D group). This chart will give the initial selection which is then compared with the selection made using the Clutch Heat Horsepower Chart and the Clutch Area Chart.

### How to select

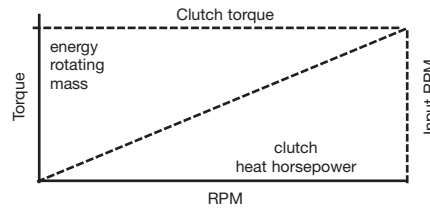

1. The area required is 406 inches. Consult the column head "Lining Area" in Specification Table (pages 126-127). Applicable clutches chosen are:

ATD-218, 528 in.<sup>2</sup>; ATD-124H, 574 in.<sup>2</sup>;  
ATD-314H, 504 in.<sup>2</sup>

2. Determine the application horsepower necessary:

$$\text{HP}/100 \text{ RPM} = \frac{325}{1,800} (100) \text{ HP}$$

$$\text{HP}/100 = 18 \text{ HP}/100 \text{ RPM}$$

Clutches selected with this application horsepower are as follows:

ATD-214H 18 HP/100 RPM, ATD-314H  
27 HP/100 RPM, ATD-118 21 HP/100 RPM.

The ATD-314 is selected as having both sufficient area and torque with minimum diameter.

$$\begin{aligned} \text{Contact velocity} &= \frac{(\text{clutch size}) (\pi) (1,800)}{12} \\ &= 6,597 \text{ ft./min.} \end{aligned}$$

Ductile material required.

**Note:** This application example is for preliminary sizing only. Contact a Wichita Sales Engineer or the factory for final selection.

Use engine torque for calculations.

When selecting the proper clutch, heat must be considered. When a clutch is slipped under load, heat is generated within the clutch. This heat as shown to the left is equal to the energy of the mass that was accelerated to speed by the clutch.

In applications where thermal requirements are of concern, consult factory for special ventilated and super ventilated clutch options.



# Standard Vent Clutches

## Coupling and Grinding Mill Clutch Selection

### Specifications

Chart C

Model Size ATD—	Slip Torque lb.in. at 100 PSI .3 CF	Max. Horsepower Per 100 RPM				Recom- mended Clear- ances Inches	Hi-Spd. Airtube Max. Speed RPM	Total Wt. lb.	Total WR <sup>2</sup> lb. ft. <sup>2</sup>	Driving Ring & Friction Disc		Lining Area in. <sup>2</sup>
		Duty								Wt.	WR <sup>2</sup>	
		A	B	C	D							
108 STVC	7,000	11.1	8	4	2	1/16-1/8	3,000	36	3	8	1.2	56
208 STVC	14,000	22.2	16	8	4	3/32-5/32	3,000	58	38	18	1.8	112
308 STVC	21,000	33.3	24	12	6	3/32-5/32	3,000	80	5.1	28	2.4	168
111 STVC	15,900	25	18	9	5	1/16-1/8	2,800	65	11	20	5	114
211 STVC	31,800	50	37	18	10	3/32-5/32	2,800	106	18	37	10	228
311 STVC	47,700	75	55	27	15	3/32-5/32	2,800	147	25	54	15	342
114H STVC	35,800	56	40	20	9	1/16-1/8	2,200	165	55	38	14	168
214H STVC	71,600	113	80	40	18	3/32-5/32	2,200	220	75	58	24	336
314H STVC	107,400	170	120	60	27	3/32-5/32	2,200	275	85	78	34	504
116 STVC	40,400	64	45	22	11	1/16-1/8	2,200	189	62	41	23	228
216 STVC	80,800	134	90	44	22	3/32-5/32	2,200	272	87	90	47	456
118 STVC	64,500	102	75	35	21	1/16-1/8	2,000	266	95	47	33	264
218 STVC	129,000	204	150	70	42	3/32-5/32	2,000	390	150	65	63	528
118H STVC	75,000	119	85	40	21	1/16-1/8	1,650	290	103	47	33	264
218H STVC	150,000	238	175	80	42	3/32-5/32	1,650	415	160	65	63	528
318H STVC	225,000	357	260	120	63	1/8-3/16	1,650	540	215	83	153	792
221STVC	175,300	278	195	97	49	3/32-5/32	1,650	500	256	127	114	724
321 STVC	263,000	417	300	150	84	1/8-3/16	1,650	735	360	210	185	1,086
124H STVC	153,700	243	180	90	40	3/32-5/32	1,400	580	390	90	100	574
224H STVC	307,400	487	360	180	80	1/8-3/16	1,400	790	535	180	200	1,148
324H STVC	461,100	731	540	270	120	5/32-7/32	1,400	1000	680	270	300	1,722
227 STVC	345,000	548	383	192	96	1/8-3/16	1,400	890	700	200	275	1,460
327 STVC	517,500	821	600	300	165	5/32-7/32	1,400	1,200	945	265	350	2,190
230H STVC	654,000	1,038	760	380	200	1/8-3/16	1,100	1,375	1,350	265	460	1,664
330H STVC	981,000	1,557	1,150	570	300	3/16-1/4	1,100	2,500	2,325	380	570	2,496
336 STVC	1,524,000	2,418	1,800	885	495	3/16-1/4	900	2,700	3,770	540	1,260	3,450
342 STVC	2,179,000	3,458	2,550	1,275	705	3/16-1/4	800	3,600	7,700	1,100	3,375	4,212
248 STVC	2,805,000	4,452	3,200	1,600	915	1/8-3/16	700	4,500	11,200	785	3,130	4,020
348 STVC	4,207,500	6,678	4,800	2,400	1,370	3/16-1/4	700	5,590	13,850	1,140	4,360	6,030
260 STVC	5,950,000	9,440	6,950	3,470	1,940	3/16-5/16	550	7,525	24,700	1,665	9,400	7,240
360 STVC	8,925,000	14,160	10,400	5,200	2,900	1/4-3/8	550	9,350	32,250	2,500	14,020	10,850
460 STVC	11,900,000	18,880	13,900	6,940	3,880	5/16-7/16	550	12,000	41,000	2,900	16,615	14,480
560 STVC	14,875,000	23,611	16,528	8,264	4,132	1/2-9/16	550	11,750	—	—	—	18,100
372 STVC	13,965,000	22,167	15,517	7,758	3,879	5/16-7/16	400	—	—	—	—	14,460

Note: Maximum air pressure – 100 PSI





# Standard Vent Clutches

## Coupling and Grinding Mill Clutch Selection Specifications

Inflation Coefficient Operating Air Pressure						Exhaust Coefficient Operating Air Pressure								
50 PSI		75 PSI		100 PSI		50 PSI			75 PSI			100 PSI		
K	U	K	U	K	U	R	E	V	R	E	V	R	E	V
15,800	2.2	7,100	2	265	1.2	60	.016	1	525	.02	1.6	240	.02	1.4
890	1.7	880	1.6	5,100	2.2	1,000	.032	2	8,200	.04	2.8	4,930	.048	2.8
456	2	825	2.2	300	1.75	3,180	.068	3	8,270	.076	3.5	8,000	.088	3.7
456	2	825	2.2	300	1.75	3,180	.068	3	8,270	.076	3.5	8,000	.088	3.7
9,600	3.1	1,560	2.4	9,600	3.8	44	.068	1.4	40	.072	1.4	34	.08	1.4
1,350	2.5	1,350	2.5	1,350	2.5	113	.052	1.6	36	.064	1.3	630	.076	2.5
1,350	2.5	1,350	2.5	1,350	2.5	71	.07	1.6	26	.077	1.3	490	.084	2.5
145	1.8	90	1.6	87	1.6	360	.096	2.5	240	.112	2.5	270	.136	2.8
145	1.8	90	1.6	87	1.6	360	.096	2.5	240	.112	2.5	270	.136	2.8
185	2	150	2	93	1.8	120	.104	2.1	140	.128	2.4	146	.158	2.7
170	2	250	2.2	160	2	124	.112	2.2	92	.128	2.2	76	.152	2.3
115	2	125	2	111	2	132	.12	2.3	89	.144	2.3	6.1	.168	2.3
25	1.6	22	1.6	26	1.8	20	.224	2	20	.256	2.2	19	.308	2.5
28	1.8	22	1.8	20	1.8	24	.264	2.4	10	.304	2.3	9.9	.352	2.2

E

# Standard Vent Clutches

## Coupling and Grinding Mill Clutch Selection Specifications

Model Size	ATD-Clutch Mounting Options	Assembly Number	Drawing Number	Model Size	ATD-Clutch Mounting Options	Assembly Number	Drawing Number	
STV 108	Clutch only	6-208-100-110-0	-900-9	STV 118H	Clutch only	6-119-100-100-0	-900-9	
	Clutch w/ SDA	6-208-100-302-0	-901-9		Clutch w/ QCDA	—		
STV 208	Clutch only	6-208-200-103-0	-900-9	STV 218H	Clutch w/ SDA	—		
	Clutch w/ SDA	6-208-200-309-0	-901-9		Clutch only	6-119-200-100-0	D-3709	
STV 308	Clutch only	6-208-300-101-0	-900-9	STV 318H	Clutch w/ QCDA	6-119-200-106-0	-106-9	
	Clutch w/ SDA	6-208-300-304-0	-901-9		Clutch w/ SDA	—		
STV 111	Clutch only	6-211-100-101-0	-900-9	STV 121	Clutch only	6-119-300-100-0		
	Clutch w/ QCDA	6-211-100-303-0	-904-9		Clutch w/ QCDA	6-119-304-305-0	-908-9	
	Clutch w/ SDA	6-211-100-304-0	-905-9		Clutch w/ SDA	6-121-100-106-0	D-2769	
STV 211	Clutch only	6-111-200-101-0	-902-9	STV 221	Clutch only	6-121-200-143-0	-903-9	
	Clutch w/ QCDA	6-111-200-311-0	-912-9		Clutch w/ QCDA	—		
	Clutch w/ SDA	6-111-200-312-0	-913-9		Clutch w/ SDA	—		
STV 311	Clutch only	6-111-300-103-0	-901-9	STV 321	Clutch only	6-121-300-120-0	-904-9	
	Clutch w/ QCDA	6-111-300-303-0	-903-9		Clutch w/ QCDA	—		
	Clutch w/ SDA	6-111-300-304-0	-904-9		Clutch w/ DIC Flange Ring	6-121-300-312-0	-912-9	
STV 114H	Clutch only	6-115-180-102-0	-902-9	STV 124H	Clutch only	6-125-100-110-0	-900-9	
	Clutch w/ QCDA	6-115-100-300-0	-903-9		Clutch w/ QCDA	—		
	Clutch w/ SDA	6-115-100-301-0	-904-9		Clutch w/ SDA	—		
STV 214H	Clutch only	6-115-280-104-0	-903-9	STV 224H	Clutch only	6-125-200-129-0	-915-9	
	Clutch w/ QCDA	6-115-200-300-0	-907-9		Clutch w/ QCDA	—		
	Clutch w/ SDA	6-115-200-301-0	-908-9		Clutch w/ SDA	—		
STV 314H	Clutch w/ DIC Flange Ring	6-115-204-301-0	-900-9	STV 324H	Clutch only	6-125-300-113-0	-912-9	
	Clutch only	6-115-380-100-0	-901-9		Clutch w/ QCDA	—		
	Clutch w/ QCDA	6-115-304-300-0	-900-9		Clutch w/ SDA	—		
STV 116	Clutch w/ SDA	6-115-300-100-0	-100-9	STV 127	Clutch only	6-127-100-112-0	-901-9	
	Clutch w/ DIC Flange Ring	6-115-300-104-0	-904-9		Clutch w/ QCDA	—		
	Clutch only	6-116-100-112-0	-900-9		Clutch w/ SDA	—		
STV 216	Clutch w/ QCDA	6-116-200-121-0	-900-9	STV 227	Clutch only	6-127-200-130-0	-905-9	
	Clutch w/ SDA	—			Clutch w/ QCDA	6-127-200-127-0	-905-9	
STV 316	Clutch only	6-116-300-118-0	-901-9	STV 327	Clutch w/ SDA	—		
	Clutch w/ QCDA	—			Clutch only	6-127-300-112-0	-903-9	
STV 118	Clutch w/ SDA	—		STV 130H	Clutch w/ QCDA	6-131-100-101-0	D-4008	
	Clutch w/ DIC Flange Ring	6-116-200-121-0	-900-9		Clutch w/ SDA	—		
STV 218	Clutch w/ QCDA	6-118-100-120-0	-904-9	STV 230H	Clutch only	6-131-200-307-0	-903-9	
	Clutch w/ DIC Flange Ring	6-118-100-304-0	D-3545		Clutch w/ QCDA	—		
STV 318	Clutch only	6-118-200-143-0	-909-9	STV 330H	Clutch w/ SDA	—		
	Clutch w/ QCDA	6-118-204-300-0	-901-9		Clutch only	6-131-300-303-0	-904-9	
	Clutch w/ DIC Flange Ring	6-118-204-300-0	-901-9		Clutch w/ QCDA	—		
	Clutch only	6-118-300-309-0	-908-9		Clutch w/ SDA	—		
	Clutch w/ QCDA	—						
	Clutch w/ DIC Flange Ring	6-118-300-311-0	-909-9					

**Note:** QCDA - Quick Change Driving Adapter. A favorite of OEMs for the extra clearance gap between the clutch and Quick Change Driving Adapter, making the clutch maintenance less time consuming. SDA - Standard Driving Adapter. A close couple design where clutch maintenance is not of prime importance.

# Standard Vent Clutches

## Coupling and Grinding Mill Clutch Selection Specifications

Model Size ATD-	Clutch Mounting Options	Assembly Number	Model Size ATD-	Clutch Mounting Options	Assembly Number
STV 430H	Clutch only	—	STV 248	Clutch only	6-148-200-100-0
	Clutch w/ QCDA	—		Clutch w/ QCDA	—
	Clutch w/ SDA	—			
STV 236	Clutch only	6-136-200-107-0	STV 348	Clutch only	6-148-300-100-0
	Clutch w/ QCDA	—		Clutch w/ QCDA	—
	Clutch w/ SDA	—			
STV 336	Clutch only	6-136-300-109-0	STV 448	Clutch only	—
	Clutch w/ QCDA	—		Clutch w/ QCDA	—
	Clutch w/ SDA	—			
STV 336H	Clutch only	6-137-300-300-0	STV 260	Clutch only	6-160-200-307-0
	Clutch w/ QCDA	6-137-300-301-0		Clutch w/ QCDA	—
	Clutch w/ SDA	—			
STV 242	Clutch only	6-142-200-301-0	STV 360	Clutch only	6-160-300-304-0
	Clutch w/ SDA	—		Clutch w/ QCDA	—
STV 342	Clutch only	6-142-300-300-0	STV 460	Clutch only	—
	Clutch w/ QCDA	—		Clutch w/ QCDA	6-160-430-301-0
	Clutch w/ SDA	—			
STV 442	Clutch only	—	STV 560	Clutch only	—
	Clutch w/ QCDA	—		Clutch w/ QCDA	6-160-582-300-0
	Clutch w/ SDA	—			

**Note:** QCDA - Quick Change Driving Adapter. A favorite of OEMs for the extra clearance gap between the clutch and Quick Change Driving Adapter, making the clutch maintenance less time consuming.  
SDA - Standard Driving Adapter. A close couple design where ease of clutch maintenance is not of prime importance.

# Standard Vent Clutches

## Coupling and Grinding Mill Clutch Selection

### Component Parts

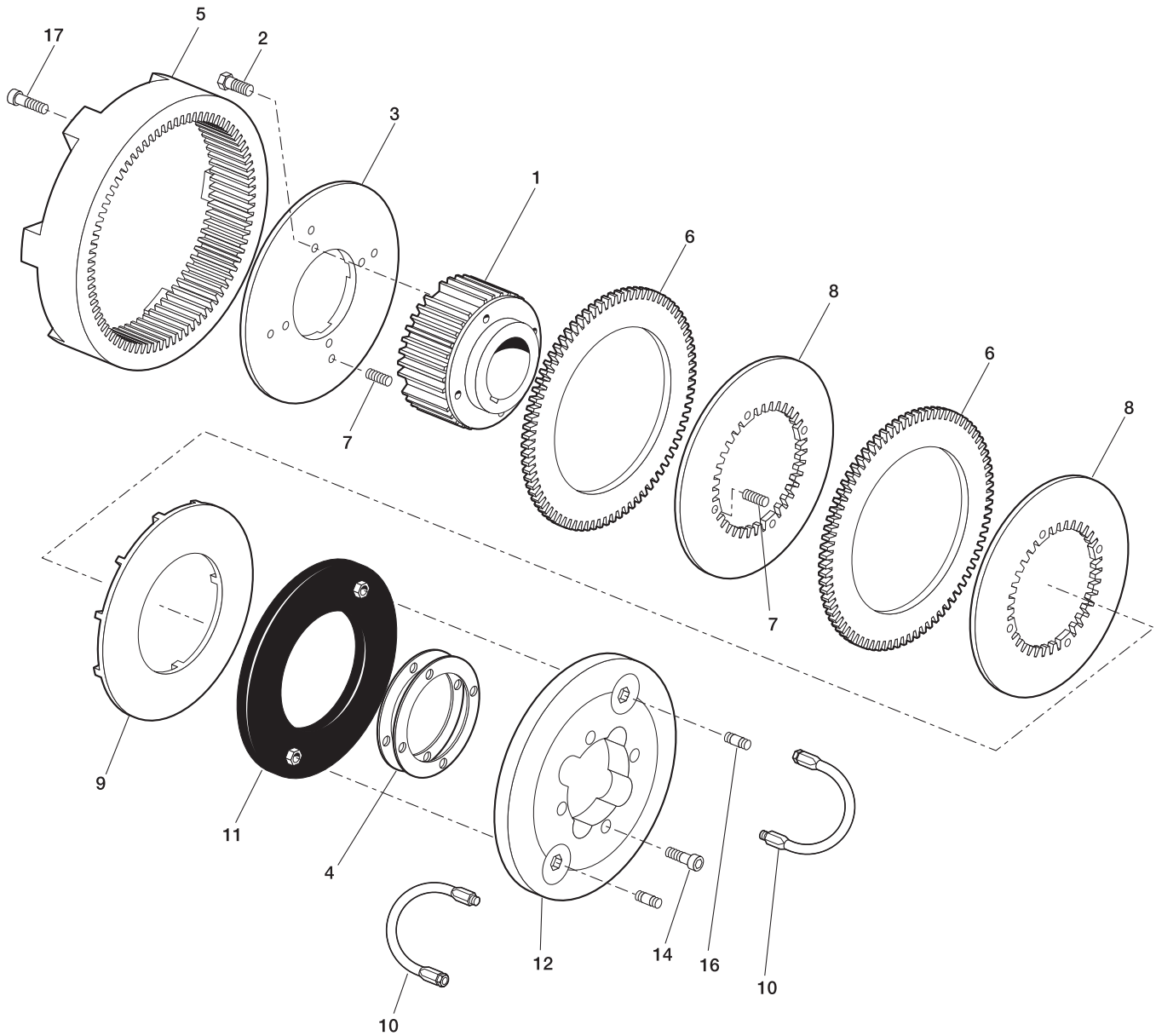

- |                   |                                  |
|-------------------|----------------------------------|
| 1. Hub            | 9. Pressure Plate                |
| 2. Hex Head Bolt  | 10. Hose Assembly                |
| 3. Backplate      | 11. Air Tube                     |
| 4. Shim           | 12. Air Tube Holding Plate       |
| 5. Driving Ring   | 14. Socket Head Capscrew         |
| 6. Friction Disc  | 16. Elbow                        |
| 7. Release Spring | 17. Bolt (Furnished by customer) |
| 8. Center Plate   |                                  |



# Standard Vent Clutches

## Coupling Clutches

- In-line power applications
- Smooth, controlled acceleration
- Unaffected by centrifugal force

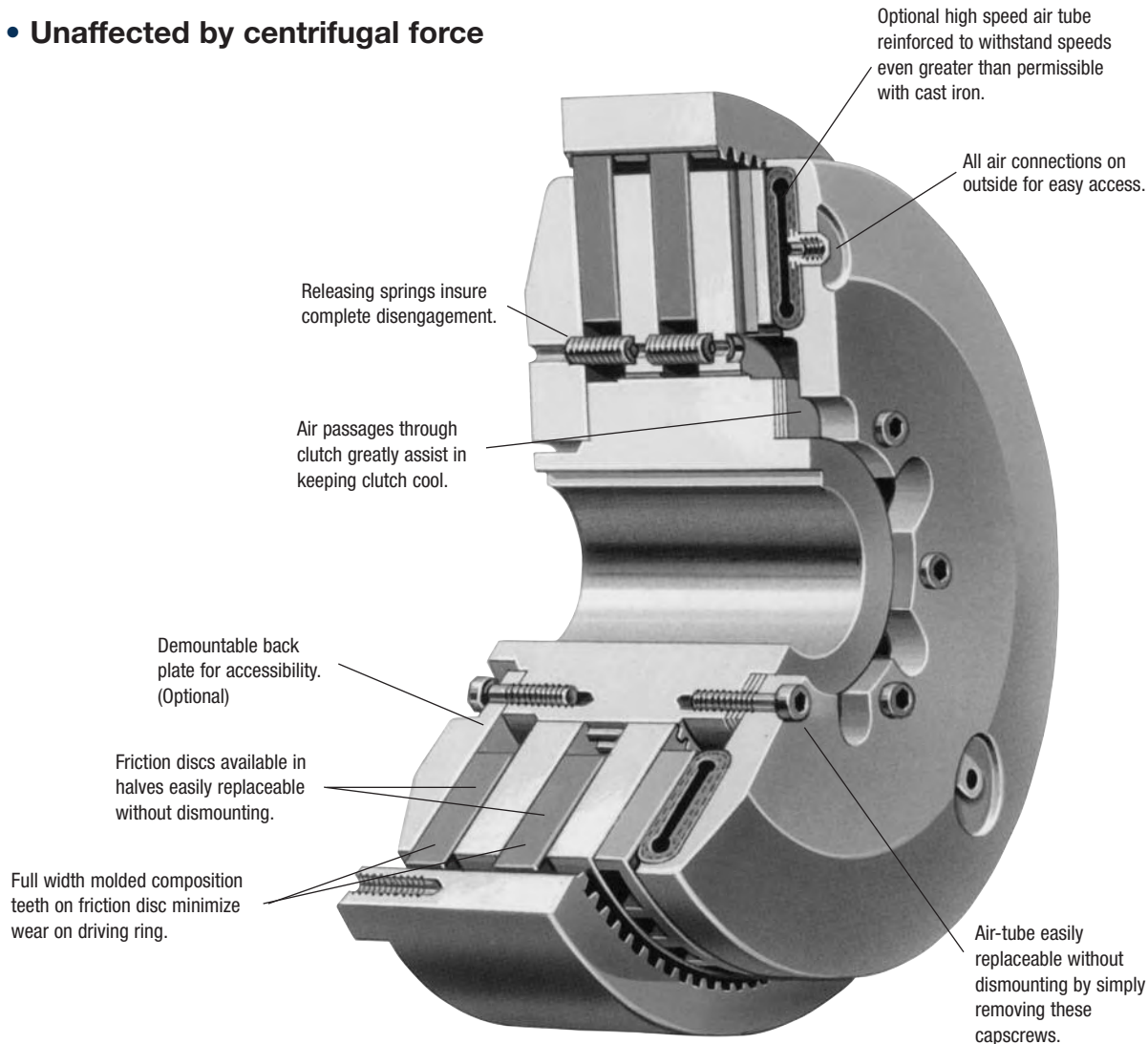

The Wichita Standard Vent Combination Clutch-Coupling is designed for reliable in-line power transmission. The simple air-tube design, with small air volume, speeds engagement and disengagement. It is unaffected by centrifugal force and has no self-energization like drum clutch designs. Ideally suited for large inertia loads where smooth controlled starts are needed.

The Wichita air-tube disc design combines all the best features of a disc type clutch with all the advantages of direct air engagement. It is

the simplest and most trouble-free method of applying air pressure yet designed.

Problems of speed, smoothness, engagement or disengagement with all types of loads...problems of compactness ...problems of simplifying maintenance and many other problems in a wide range of applications are quickly solved with Wichita clutches or brakes.

# Standard Vent Clutches

## Coupling Clutches

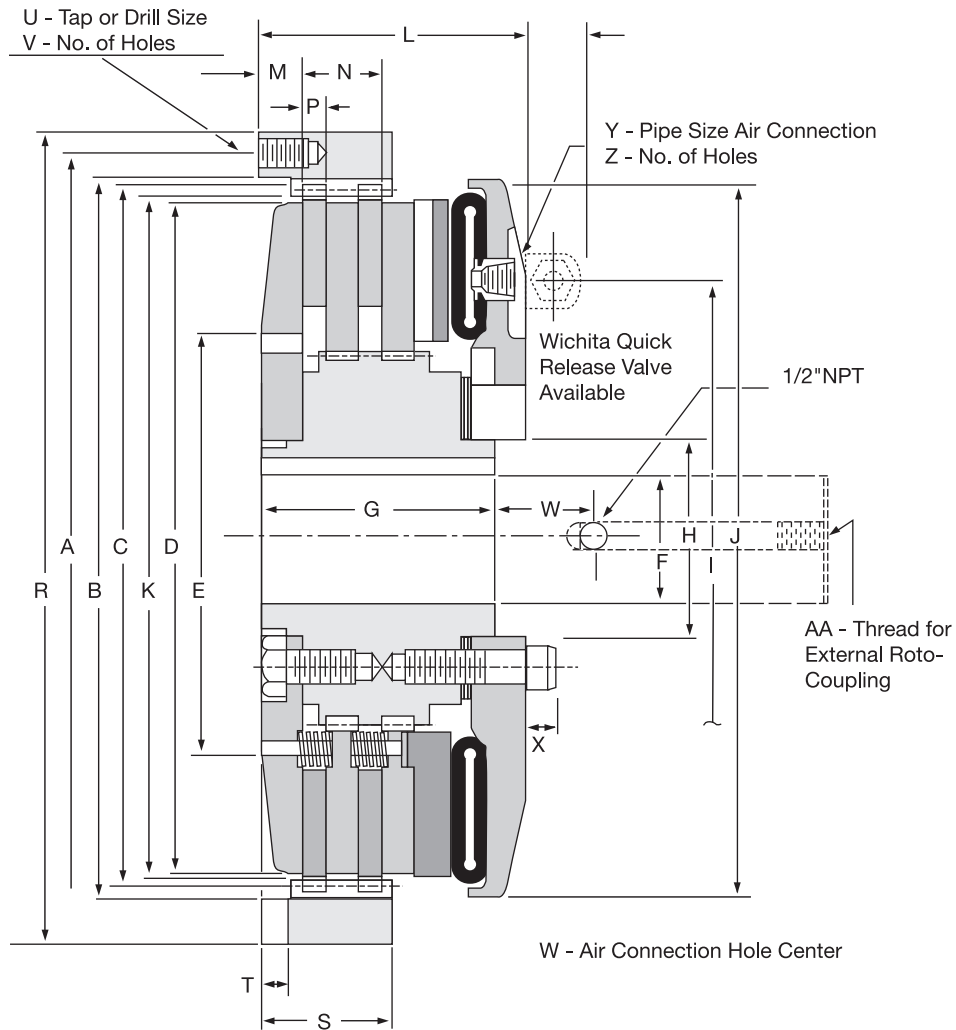

**Notes:**

1. Air Hose Kits, page 141.
2. Quick Release Valves, page 144.
3. Roto-couplings, page 144.

**Note:** For mounting, use socket head capscrews conforming to the ASTM-574-97a.

# Standard Vent Clutches

## Coupling Clutches

**Dimensions: inches** (Consult factory for drawing before final layout.)

Model Size ATD-	+.003" -.000"		Max Bore Rect. Key							
	A	B	C	D	E	F	G	H	I	J
108 STVC	9.625	8.873	8.50	8	8	1.93	2.75	1.938	6.625	9.625
208 STVC	9.625	8.873	8.50	8	8	1.93	4.125	1.938	6.625	9.625
308 STVC	9.625	8.873	8.50	8	8	1.93	5.50	1.938	6.625	9.625
111 STVC	13.375	12.375	12	11	11	3.00	3	3	8.50	11.938
211 STVC	13.375	12.375	12	11	11	3.00	4.25	3	8.50	11.938
311 STVC	13.375	12.375	12	11	11	3.00	5.563	3	8.50	11.938
114H STVC	16.25	15.125	14.67	14	9.375	3.38	4.313	4.50	12.50	16.313
214H STVC	16.25	15.125	14.67	14	9.375	3.38	5.75	4.50	12.50	16.313
314H STVC	16.25	15.125	14.67	14	9.375	3.38	7.188	4.50	12.50	16.313
118 STVC	20.75	19.500	18.75	18	11.50	4.00	4.75	5.25	14	19.375
218 STVC	20.75	19.500	18.75	18	11.50	4.00	6.25	5.25	14	19.375
118H STVC	20.75	19.500	18.75	18	11.50	4.00	4.75	5.25	16	21.625
218H STVC	20.75	19.500	18.75	18	11.50	4.00	6.25	5.25	16	21.625
318H STVC	20.75	19.500	18.75	18	11.50	4.00	7.75	5.25	16	21.625
321 STVC	23.75	22.500	21.75	21	14	5.38	9.125	7	16	21.625
124H STVC	26.75	25.500	24.75	24	16	5.38	5.875	7	21	27
224H STVC	26.75	25.500	24.75	24	16	5.38	7.25	7	21	27
324H STVC	26.75	25.500	24.75	24	16	5.38	9.375	7	21	27
327 STVC	29.75	28.500	27.75	27	19.50	7.00	9.75	9	21	27
230H STVC	32.75	31.500	30.75	30	22.50	7.00	8.50	9	24.75	32.375
330H STVC	32.75	31.500	30.75	30	22.50	7.00	11.50	9	24.75	32.375
336H STVC	39.75	38.500	37.50	36	28	8.00	12.625	13.50	30.50	38.25
342 STVC	47.25	45.000	44	42	42	10.00	11.875	21	35	44.125
248 STVC	54	52.000	51	48	35	12.00	10.875	21	40	52.375
348 STVC	54	52.000	51	48	35	12.00	13.625	21	40	52.375
260 STVC	64.75	62.750	62	60	36.125	14.00	16.25	22.625	46.50	61.50
360 STVC	64.75	62.750	62	60	36.125	14.00	20	22.625	46.50	61.50
460 STVC	64.75	62.750	62	60	36.125	14.00	23.50	22.625	46.50	61.50

Model Size ATD-	K	L	M	N	P	R	S	T	U	V	W	X	Y	Z
	108 STVC	8.247	4	.75	—	.438	10.375	1.375	.50	1/2 NC	6	2.25	.50	1/2
208 STVC	8.247	5.313	.75	1.75	.438	10.375	2.625	.50	1/2 NC	6	2.25	.50	1/2	2
308 STVC	8.247	6.625	.75	3.063	.438	10.375	3.875	.50	1/2 NC	6	2.25	.50	1/2	2
111 STVC	11.763	4.125	.875	—	.50	14.375	1.50	.50	5/8 NC	8	2.50	.438	1/2	2
211 STVC	11.763	5.25	.875	1.75	.50	14.375	2.875	.50	5/8 NC	8	2.50	.438	1/2	2
311 STVC	11.763	6.75	.875	3	.50	14.375	4.25	.50	5/8 NC	8	2.50	.438	1/2	2
114H STVC	14.451	5.125	1.125	—	.625	17.50	1.875	.625	5/8 NC	6	2.25	.75	1/2	2
214H STVC	14.451	6.50	1.125	2	.625	17.50	3.25	.75	5/8 NC	6	2.25	.75	1/2	2
314H STVC	14.451	8	1.125	3.375	.625	17.50	4.75	.75	5/8 NC	6	2.25	.75	1/2	2
118 STVC	18.375	5.625	1.313	—	.625	22	1.938	.75	5/8 NC	6	2.438	1	1/2	3
218 STVC	18.375	7.125	1.313	2.125	.625	22	3.50	.75	5/8 NC	6	2.438	1	1/2	3
118H STVC	18.375	5.625	1.313	—	.625	22	1.938	.75	5/8 NC	6	2.438	1	1/2	3
218H STVC	18.375	7.25	1.313	2.125	.625	22	3.50	.75	5/8 NC	6	2.438	1	1/2	3
318H STVC	18.375	8.688	1.313	3.75	.625	22	5.125	.75	5/8 NC	6	2.438	1	1/2	3
321 STVC	21.350	10.125	1.625	4.25	.75	25	6.125	1	5/8 NC	6	2.375	1	1/2	3
124H STVC	24.312	6.563	1.625	—	.875	28	2.813	.75	5/8 NC	6	2.75	1	1/2	3
224H STVC	24.312	8.625	1.625	2.75	.875	28	4.50	.75	5/8 NC	6	2.75	1	1/2	3
324H STVC	24.312	10.563	1.625	4.625	.875	28	6.25	.75	5/8 NC	6	2.75	1	1/2	3
327 STVC	27.361	10.75	1.625	4.625	.875	31	6.50	1.375	5/8 NC	12	2.375	1	1/2	3
230H STVC	30.361	10.125	1.625	3.75	1.25	34	5.625	1.125	5/8 NC	12	2.875	1	1/2	4
330H STVC	30.361	12.75	1.625	6.25	1.25	34	8.125	1.125	5/8 NC	12	2.875	1	1/2	4
336H STVC	37.159	14.375	1.938	7.125	1.375	41	9	1.50	5/8 NC	16	2.875	1	1/2	4
342 STVC	43.627	14	2	7.375	1.375	49.25	9.625	1.75	1" NC	12	3.50	1.25	1/2	4
248 STVC	50.815	13.75	2.625	4.125	1.375	56	7.125	2	1" NC	12	3.50	1.25	1/2	4
348 STVC	50.815	15.75	2.625	6.875	1.375	56	9.875	2	1" NC	12	3.50	1.25	1/2	4
260 STVC	61.700	16.25	3	5.50	3	66.75	9	2.50	1" NC	24	2	2	1/2	6
360 STVC	61.700	20	3	9	3	66.75	13	2.50	1" NC	24	2	2	1/2	6
460 STVC	61.700	23.375	3	12.50	3	66.75	16.50	2.50	1" NC	24	2	2	1/2	6

# Standard Vent Clutches

## Coupling Clutches

### Standard Driving Adapters

The driving adapter is designed to allow the clutch to be used in a shaft-to-shaft or through-shaft coupling arrangement.

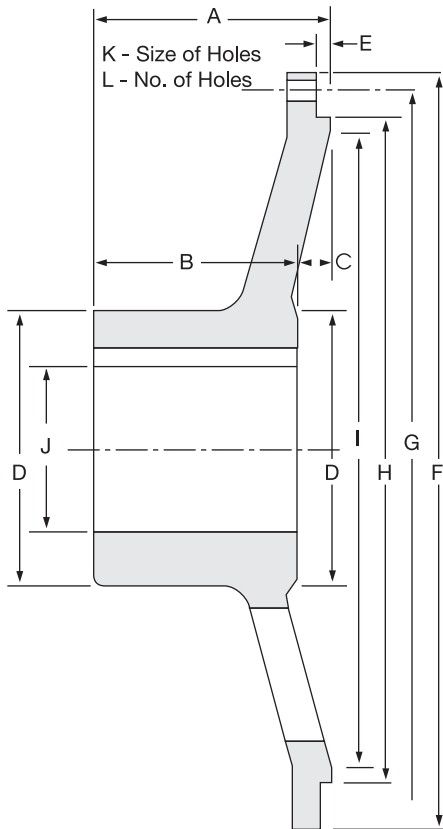

Standard Adapter (Standard Gap)

### Quick Change Adapters

The quick change feature, using a driving elbow piece between the driving adapter and the clutch driving ring, enables replacement of any wearing clutch part without disturbing either shaft.

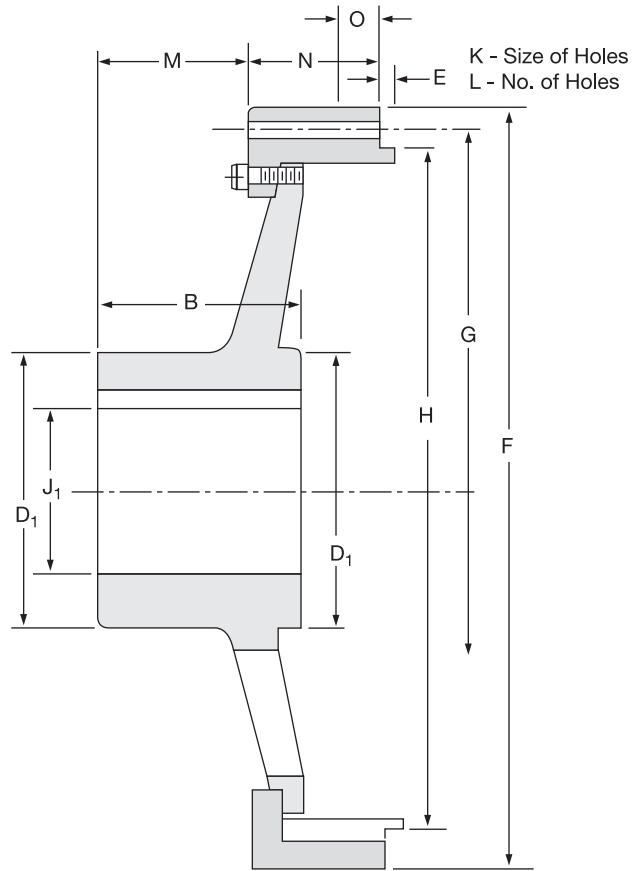

Quick Change Adapter (Access Gap)



# Standard Vent Clutches

## Coupling Clutches

### Dimensions: inches

Size	A	B	C	D	D <sub>1</sub>	E	F	G	H	+0.003" -0.000"
8	3.125	3	.125	3.75	—	.125	10.375	9.625	8.869	
11	3.625	3.25	.375	6.25	5	.125	14.375	13.375	12.371	
14H	5.375	4.75	.625	7	6.25	.25	17.50	16.25	15.121	
18	6.875	5.75	1.125	8	8	.375	22	20.75	19.496	
18H	6.875	5.75	1.125	8	8	.375	22	20.75	19.496	
21	6.75	6	.75	9.50	9	.25	25	23.75	22.496	
24H	8.375	7.313	1.063	10	12	.25	28	26.75	25.495	
27	8.75	7.75	1	11	11.50	.25	31	29.75	28.495	
30H	9.25	8.75	.50	14	14	.25	34	32.75	31.495	
36	10.50	10	.50	15	14	.25	41	39.75	38.495	
42	11	10	1	15	15	.25	49.25	47.25	44.995	
48	—	13.625	—	—	20	.50	56	54	52.000	
60	—	16.25	—	24	—	.375	66.75	64.75	62.750	

Size	I	Max. Bore Rect. Key J	J <sub>1</sub>	K	L	M	N	O
8	8.375	2.50	—	.531	6	1.875	*	—
11	11.75	4.13	3.375	.656	8	2	2.50	—
14H	14.50	4.75	4.125	.656	6	2.125	3.125	—
18	18.50	5.25	5.25	.688	6	4.375	3.50	—
18H	18.50	5.25	5.25	.688	6	4.375	3.50	—
21	21.75	6.25	6	.688	6	4	6.25	—
24H	24.50	6.63	6.625	.688	6	5.188	5.50	—
27	27.75	7.25	7.625	.688	12	5.563	4.625	—
30H	30.50	9.25	9.25	.688	12	6.50	5.75	—
36	37.50	10.00	9.25	.688	16	7.875	4.125	—
42	44	10.00	10	1.031	12	7.438	5.688	—
48	—	—	15	1.031	12	10.125	6.125	—
60	—	18.00	—	1.031	24	12.25	11.50	2.50

\* Consult Factory

**Note:** For mounting, use socket head capscrews conforming to the ASTM-574-97a.

E

# Standard Vent Clutches

## Grinding Mill Clutches

- Designed for heavy duty applications
- Quick, smooth starting
- High heat dissipation for jogging and inching

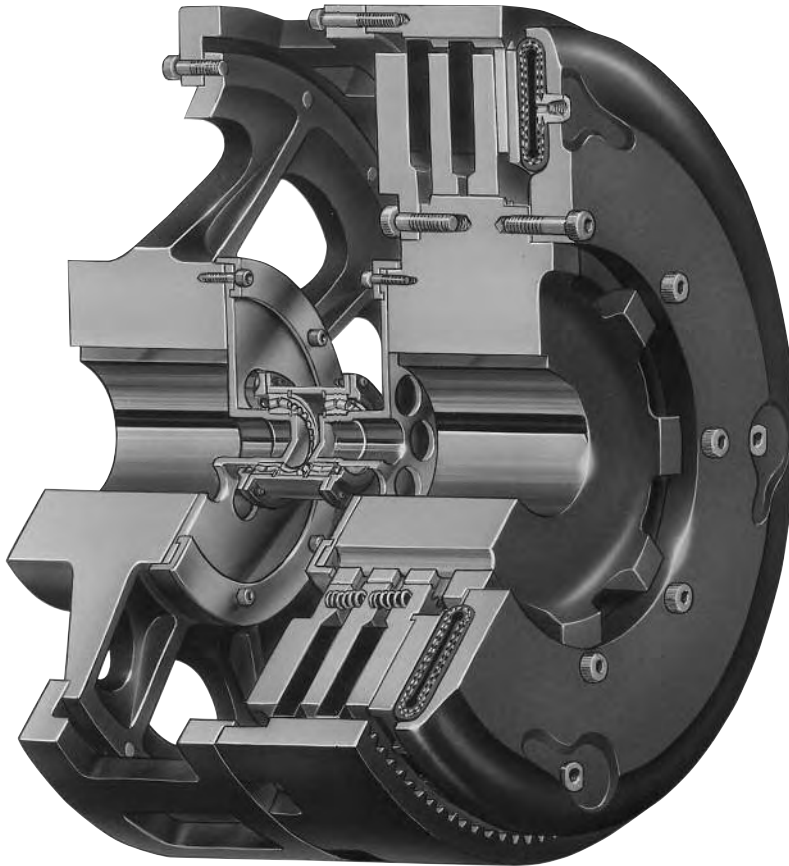

Wichita Grinding Mill Clutches are specially designed to provide quick, smooth starts with limited current surge for heavy duty grinding mills. The clutch is adaptable to remote control allowing centralized operation through simple air or electric circuits.

- No adjustment or lubrication
- Eliminates need for special high torque motors
- Torque capacity not affected by centrifugal force
- High heat dissipation for jogging and inching
- New high coefficient, high energy absorbing friction material standard for grinding mill applications

### Standard Torque Motor with Wichita Clutch vs. High Torque Motor

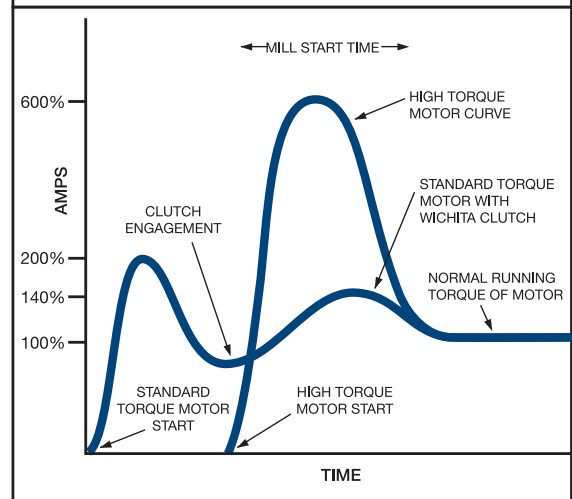

# Standard Vent Clutches

## Grinding Mill Clutches Specifications

Technical						Capacity				
Model Size ATD-	Air Supply	Total Weight lb.	Total WR <sup>2</sup> lb.ft. <sup>2</sup>	Driving Adapter Ring & Disc		Diameter Friction Disc-in.	Max. Speed (RPM) For 6000 FPM @ Fric Disc O.D.	HP per 100 RPM	Lining Area in. <sup>2</sup>	Rated Torq. in.lbs. 100 PSI
				Wt.	WR <sup>2</sup>					
211-X GMC	5/8"-18	130	24	57	16	11	2,100	18	228	42,294
214H-X GMC	5/8"-18	333	111	152	58	14	1,640	40	336	95,228
314H-X GMC	5/8"-18	385	132	190	75	14	1,640	60	504	142,842
318H-X GMC	1"-14	727	333	356	220	18	1,275	120	792	299,250
321-X GMC	1"-14	980	663	500	280	21	1,100	150	1,086	349,790
324H-X GMC	1"-14	1,350	970	590	600	24	950	270	1,722	613,130
327-X GMC	1"-14	1,580	1,130	675	540	27	850	300	2,190	688,275
230H-X GMC	1"-14	2,126	2,046	1,036	1,150	30	760	380	1,664	869,820
330H-X GMC	1"-14	2,600	2,100	1,125	1,250	30	760	570	2,496	1,304,730
430H-X GMC	1"-14	3,578	2,980	1,497	1,148	30	760	760	3,328	1,739,640
336H-X GMC	1"-14	3,550	4,650	1,510	2,215	36	640	885	3,450	2,134,650
342-X GMC	1-1/2"-12	4,815	10,505	2,315	6,130	42	540	1,275	4,212	2,898,070
248-X GMC	1-1/2"-12	6,580	16,275	2,825	9,523	48	475	1,600	4,020	3,730,650
348-X GMC	1-1/2"-12	7,540	18,470	3,274	9,700	48	475	2,400	6,030	5,595,975
448-X GMC	1-1/2"-12					48	475	3,200	8,040	7,461,300
260-X GMC	1-1/2"-12	10,600	37,300	5,750	23,600	60	380	3,470	7,240	7,913,500
360-X GMC	1-1/2"-12	13,390	47,850	5,900	27,550	60	380	5,200	10,850	11,870,250
460-X GMC	1-1/2"-12	16,860	57,705	7,500	33,238	60	380	6,940	14,480	15,827,000
560-X GMC	1-1/2"-12	20,050	78,642	8,300	28,512	60	380	8,675	18,100	19,783,750
372-X GMC	1-1/2"-12					72	300	7,758	14,460	18,573,450
472-X GMC	1-1/2"-12					72	300	10,344	19,280	24,764,600
572-X GMC	1-1/2"-12					72	300	12,930	24,100	30,955,750

E



# Standard Vent Clutches

## Grinding Mill Quick Selection Chart

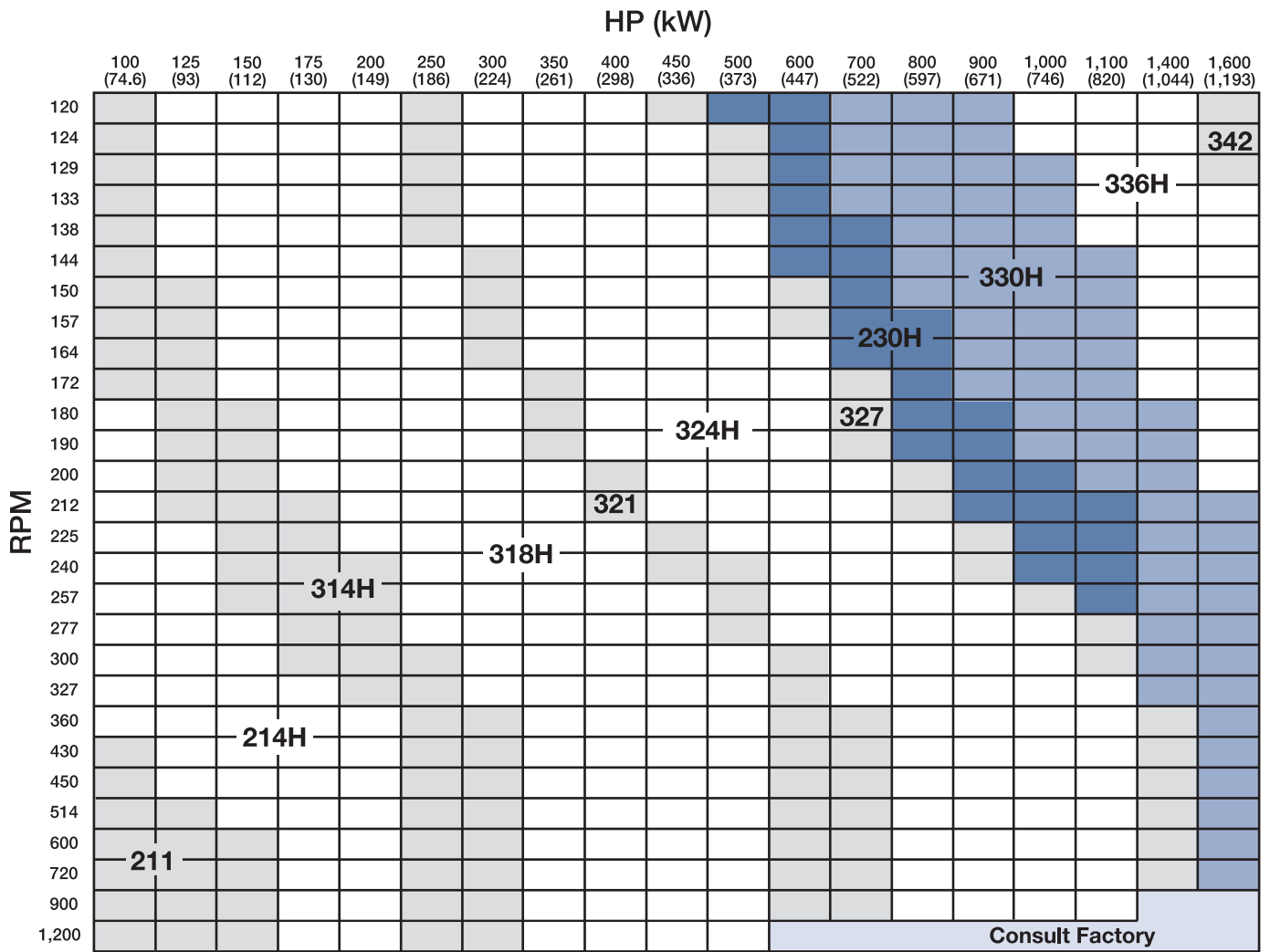

# Standard Vent Clutches

## Grinding Mill Quick Selection Chart

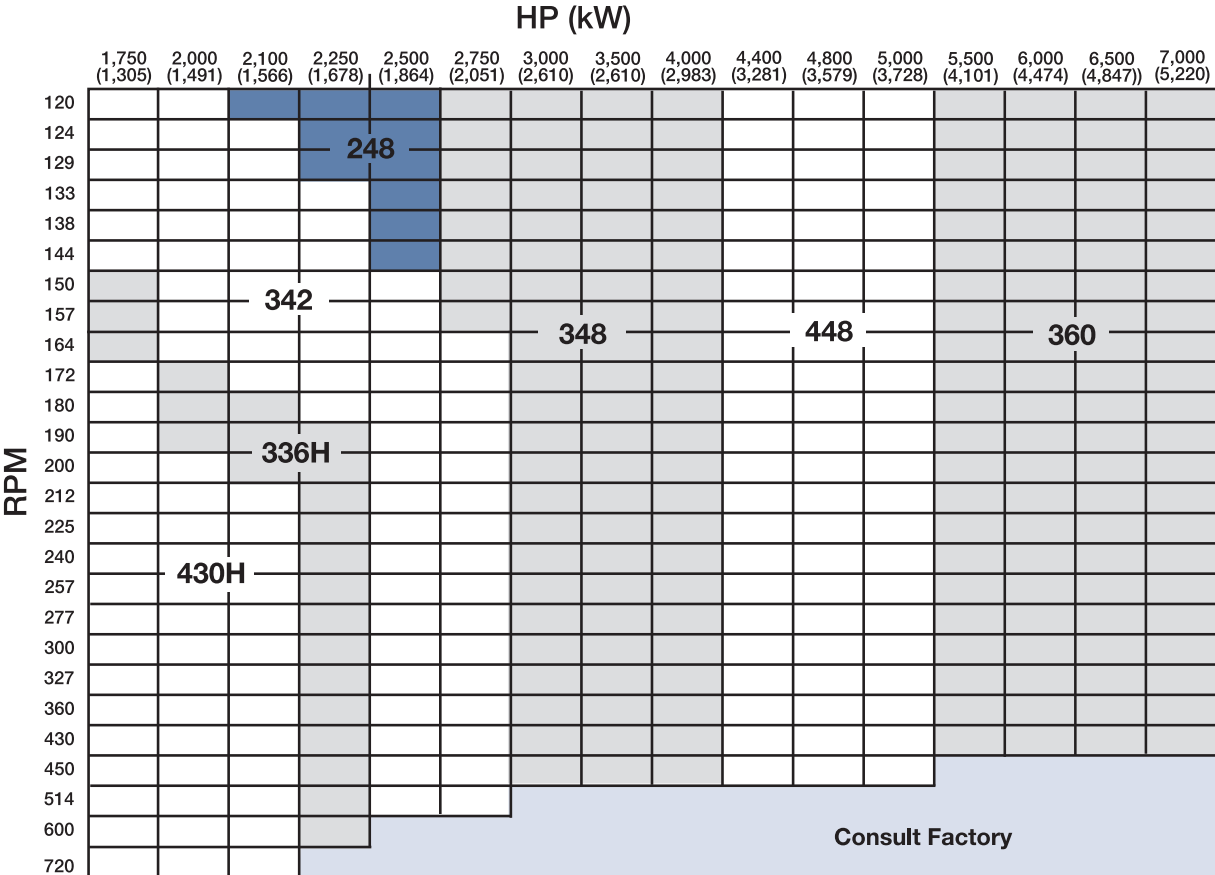
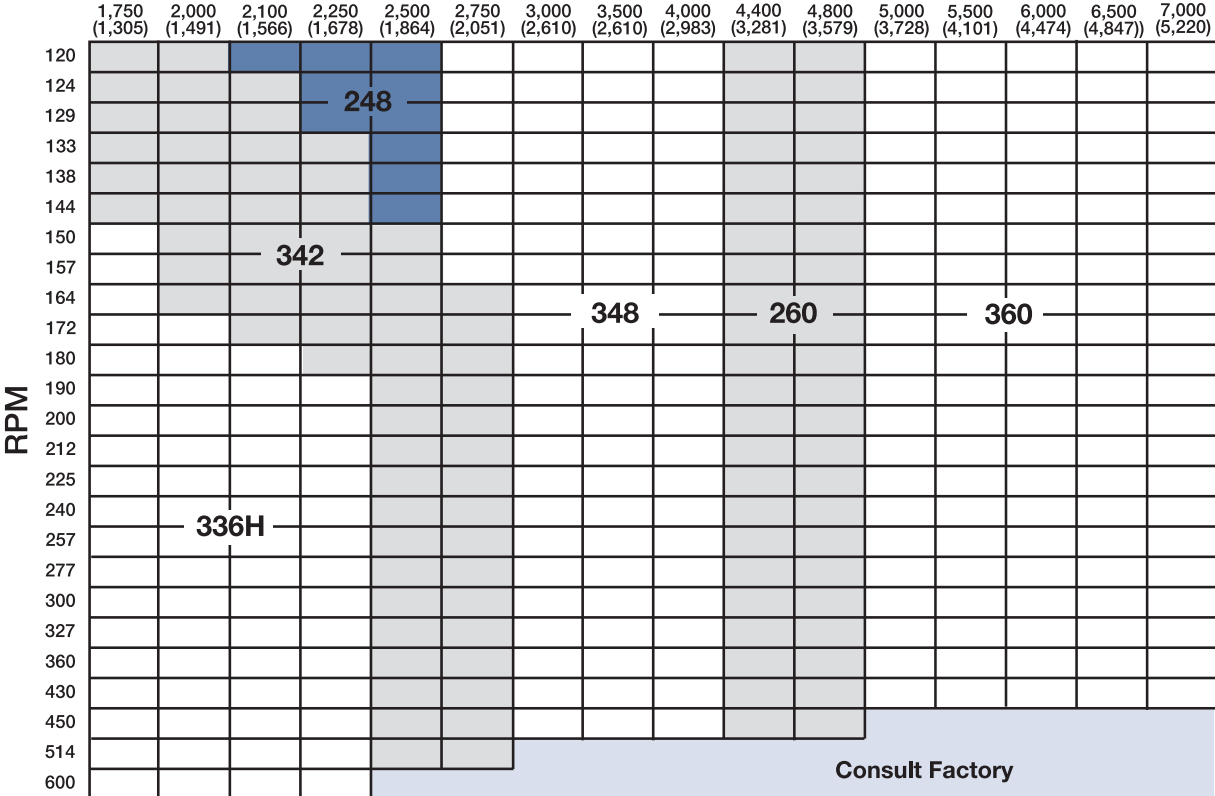

# Standard Vent Clutches

## Grinding Mill Quick Selection Chart

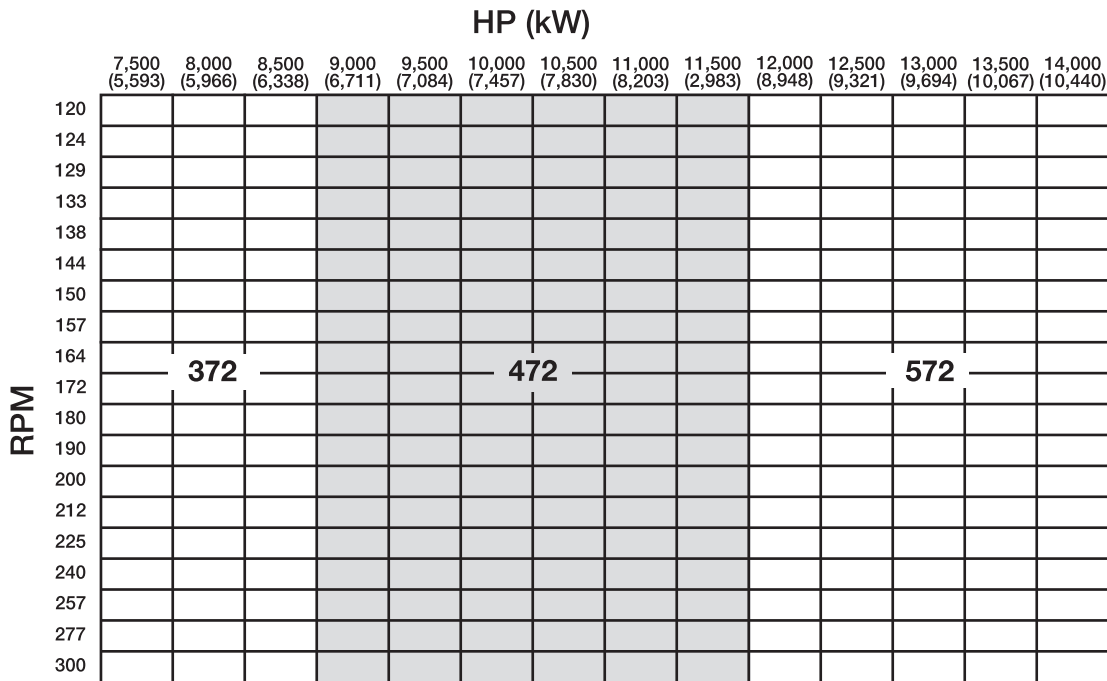
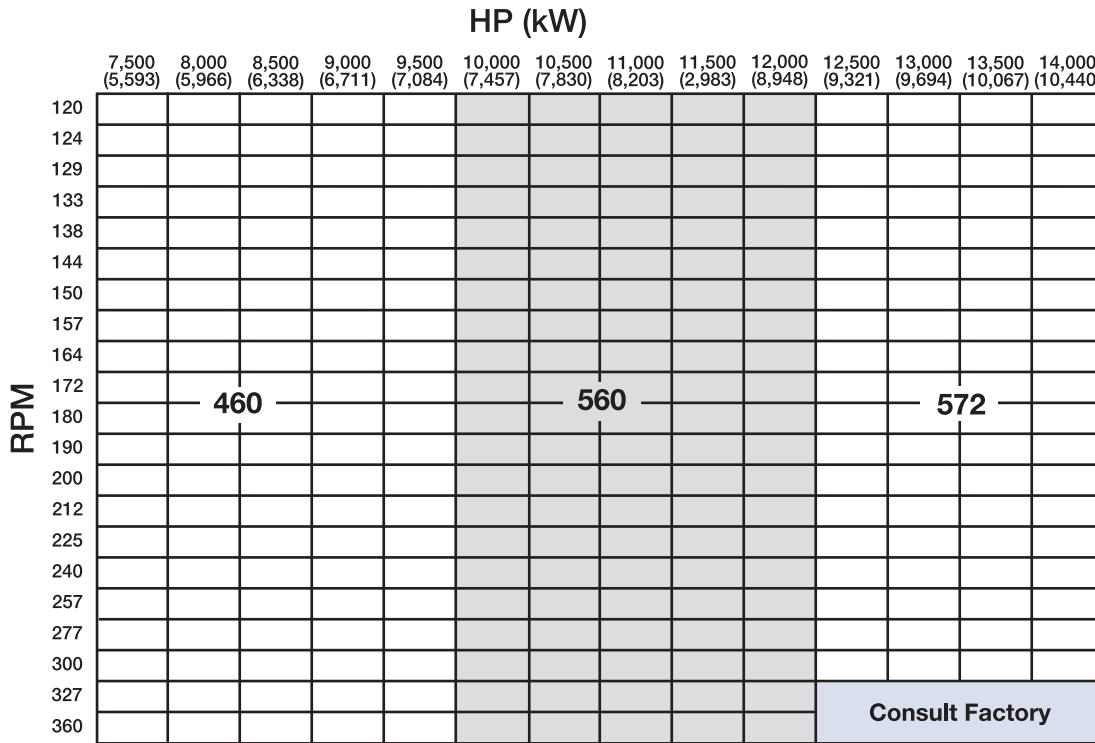

# Standard Vent Clutches

## Air Hose Kits

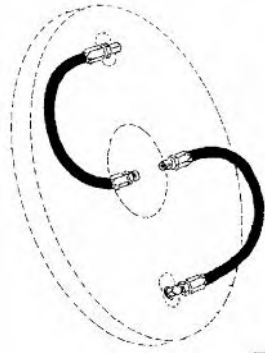

Model	Part Number
8"	8-908-812-200-3 8-908-821-200-4 QRV 8-911-813-200-3 HS
11"	8-911-812-200-4 8-911-821-200-5 QRV 8-911-813-200-3 HS
14"	8-914-812-201-5 8-914-821-202-5 QRV 8-914-813-204-3 HS

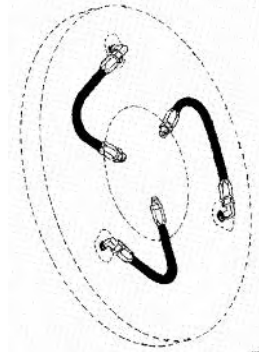

Model	Part Number
18"	8-918-812-301-5 8-918-821-300-5 QRV 8-918-815-301-3 HS
21"/18H	8-921-812-301-5 8-921-821-302-5 QRV 8-921-812-300-5 HS
24"	8-924-812-300-5 8-924-821-302-5 QRV
27"/24H	8-927-812-300-5 8-927-821-301-5 QRV 8-927-812-302-5 HS

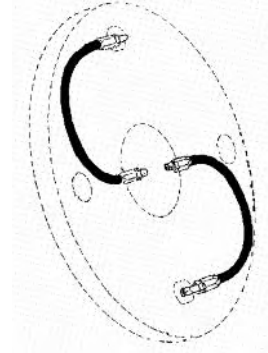

Model	Part Number
30"	8-930-815-201-5
30"H	8-931-821-200-5 QRV 8-931-812-200-5 HS
36"	8-936-815-200-5 8-936-821-200-5 QRV 8-936-815-201-5 HS
42"	8-942-815-200-5 8-942-821-200-5 QRV
48"	8-948-815-200-5 8-948-821-200-5 QRV

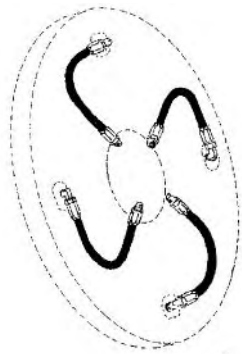

Model	Part Number
30"H	8-931-821-400-5 QRV

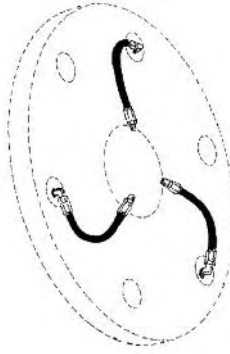

Model	Part Number
60"	8-960-812-300-5 8-960-834-300-5 QRV

### 1 Spud Hose Kits

Model	Part Number
18"	8-918-815-101-3 HS
21"	8-921-815-101-3 HS

Air hose kits contain all necessary parts (fittings, hoses and extensions) to completely plumb the clutch.

Optional Quick Release Valves can replace elbows on most units (see page 144).

Roto-couplings (see page 144).

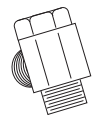

# Standard Vent Clutches

## Grinding Mill Clutches

### Driving Adapters

The driving adapter is designed to allow the clutch to be used in a shaft-to-shaft or through-shaft coupling arrangement. The quick-change feature, using a driving elbow piece between the driving adapter and the clutch driving ring, enables replacement of any wearing clutch part without disturbing either shaft.

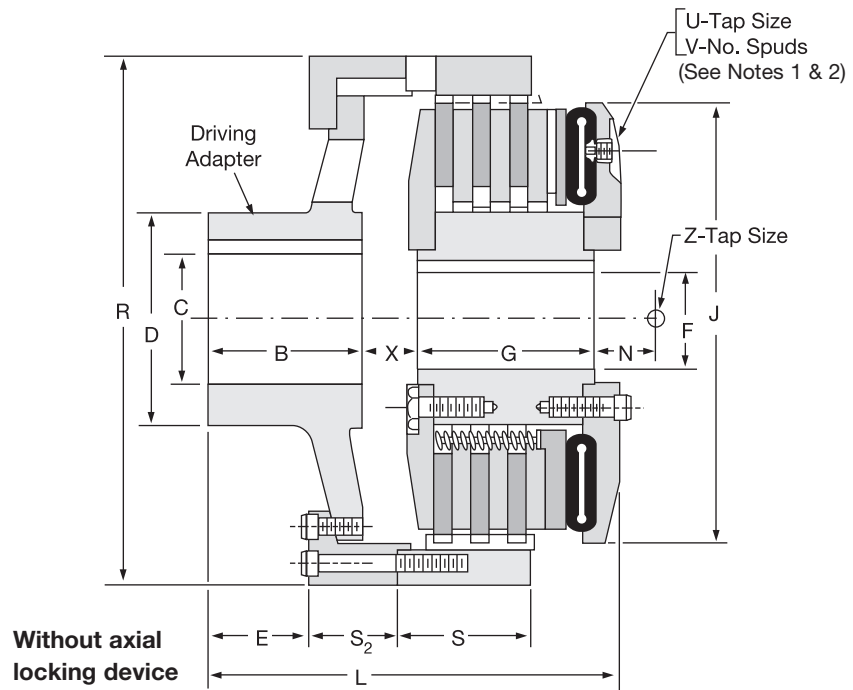

**Dimensions: inches** (Consult factory for drawing before final layout.)

Model Size	B	C* Max. Bore Rect. Key	C1* Max. Bore Rect. Key	D	E	F* Max. Bore Rect. Key	G	J	L	L <sub>1</sub>
211 GMC	3.00	3.00	—	5.00	2.00	3.00	4.25	11.94	10.00	—
214H GMC	3.25	4.13	—	6.25	2.13	3.38	5.75	16.31	11.88	—
314H GMC	3.25	4.13	—	6.25	2.13	3.38	7.18	16.31	13.38	—
318H GMC	6.00	4.00	—	6.00	4.38	4.00	7.31	21.31	17.43	—
321 GMC	6.00	6.50	—	9.00	4.00	5.38	8.63	21.31	20.50	—
324H GMC	7.31	7.50	—	10.00	5.56	5.38	8.43	27.00	21.56	—
327 GMC	7.31	7.63	—	11.50	5.56	7.00	9.00	27.00	20.94	—
230H GMC	8.75	9.38	9.38	14.00	6.50	7.00	7.88	32.38	22.63	24.43
330H GMC	8.75	9.38	9.38	14.00	6.50	7.00	10.88	32.38	25.25	26.94
336H GMC	10.00	9.38	9.38	14.00	7.88	8.00	12.88	38.25	26.75	34.75
342 GMC	10.00	12.00	12.00	18.00	7.43	10.00	11.88	44.13	27.63	34.50
248 GMC	13.63	15.00	13.25	20.00	10.13	12.00	10.88	52.38	29.63	36.88
348 GMC	13.63	15.00	13.25	20.00	10.13	12.00	13.63	52.38	32.13	39.50
260 GMC	16.25	18.00	15.00	24.00	12.25	14.00	16.25	61.50	40.00	42.50
360 GMC	16.25	18.00	15.00	24.00	12.25	14.00	20.00	61.50	43.75	46.25
460 GMC	16.25	18.00	15.00	24.00	12.25	14.00	23.50	61.50	47.13	49.63
560 GMC	20.25	17.00	17.00	30.00	16.25	17.00	27.00	61.50	—	57.20

\* Maximum bore uses rectangular key, contact Wichita Engineering.

**Note:** For mounting, use socket head capscrews conforming to the ASTM-574-97a.



# Standard Vent Clutches

## Grinding Mill Clutches

### With axial locking device

The axial locking device is an optional feature offered by Wichita. This device prevents damage to the mill motor bearings during motor start-up by axially locking the armature to magnetic center.

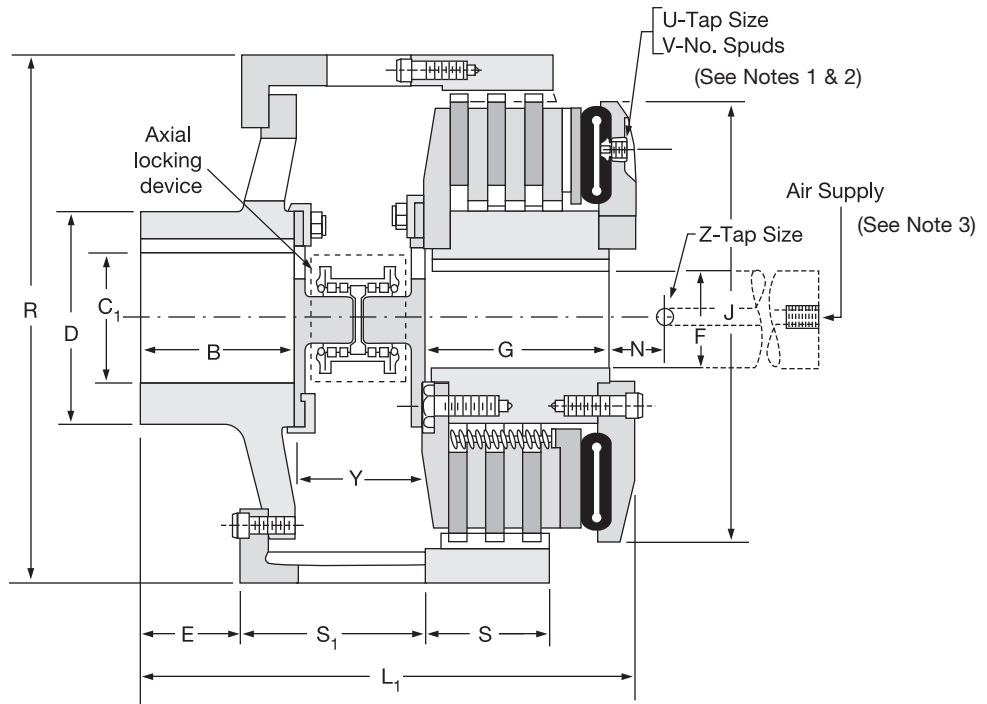

### Notes:

1. Air Hose Kits, page 141.
2. Quick Release Valves, page 144.
3. Roto-couplings, page 144.

Model Size ATD-	N	R	S	S <sub>1</sub>	S <sub>2</sub>	U tap size	V spuds	X	Y	Z tap size	Air Supply
211 GMC	2.25	13.63	N/A	—	5.38	1/2" NPT	2	1.62	—	1/2" NPT	5/8"-18
214H GMC	2.25	17.50	3.25	—	3.13	1/2" NPT	2	2.13	—	1/2" NPT	5/8"-18
314H GMC	2.25	17.50	4.75	—	3.13	1/2" NPT	2	2.13	—	1/2" NPT	5/8"-18
318H GMC	2.43	22.00	5.88	—	3.50	1/2" NPT	3	3.06	—	1/2" NPT	1"-14
321 GMC	2.38	25.00	6.25	—	6.25	1/2" NPT	3	4.75	—	1/2" NPT	1"-14
324H GMC	2.75	28.00	6.25	—	5.50	1/2" NPT	3	4.50	—	1/2" NPT	1"-14
327 GMC	2.38	31.00	6.50	—	4.63	1/2" NPT	3	3.75	—	1/2" NPT	1"-14
230H GMC	2.75	34.00	5.63	5.75	5.75	1/2" NPT	4	4.25	5.00	1/2" NPT	1"-14
330H GMC	2.88	34.00	8.13	7.43	5.75	1/2" NPT	4	4.25	5.00	1/2" NPT	1"-14
336H GMC	2.88	41.00	9.13	12.13	4.00	1/2" NPT	4	2.50	10.00	1/2" NPT	1"-14
342 GMC	3.50	49.25	9.63	12.69	5.69	1/2" NPT	4	3.50	10.00	1/2" NPT	1-1/2"-12
248 GMC	3.75	56.00	7.38	13.25	6.13	1/2" NPT	4	2.75	10.00	1/2" NPT	1-1/2"-12
348 GMC	3.50	56.00	9.88	13.38	6.13	1/2" NPT	4	2.75	10.00	1/2" NPT	1-1/2"-12
260 GMC	2.00	66.75	9.00	14.00	11.50	1/2" NPT	6	7.50	10.00	1/2" NPT	1-1/2"-12
360 GMC	2.00	66.75	13.00	14.00	11.50	1/2" NPT	6	7.50	10.00	1/2" NPT	1-1/2"-12
460 GMC	2.00	66.75	16.50	14.00	11.50	1/2" NPT	6	7.50	10.00	1/2" NPT	1-1/2"-12
560 GMC	4.0	74.25	20.13	14.60	—	1/2" NPT	6	—	10.00	1/2" NPT	1-1/2"-12

# Standard Vent Clutches

## Grinding Mill Clutches

### Quick Release Valve

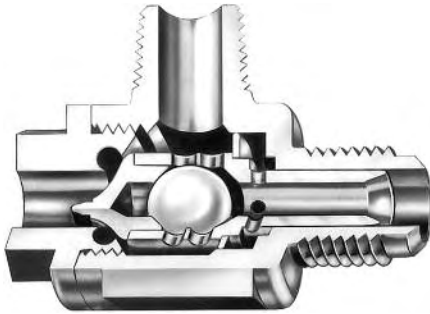

8-263-610-011-1 7/8" - 14 Thread  
8-263-610-021-1 1/2" NPT

The Wichita Springless Quick Release Valve discharges twice as fast as any other valve tested in our laboratory and is four to five times faster than some common makes of valves.

This valve will close and seal with less than 20 lbs. pressure. Most others require 25 to 30 lbs. to definitely seal. In actual tests, the Wichita Valve made many hundreds of thousands of engagements and disengagements before the slightest leak occurred, or any parts needed replacement. Other valves which were tested required major replacement in fewer than 20,000 cycles.

### Quality Material

- Body and Cap: High strength aluminum alloy
- Stem: Molded nylon
- Check Valve: Nylon ball
- "O" Ring: Neoprene

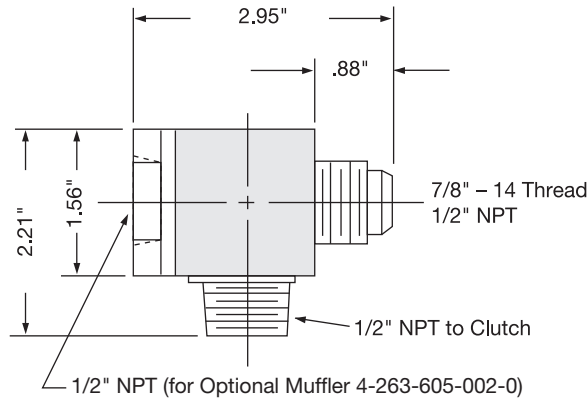

Standard thread arrangement of 1/2" size. 1/2" pipe thread on the tube connection and choice of 1/2" pipe thread, or standard 7/8-14NF thread for flared fitting thread on inlet connection. (Fits standard No. 10 high-pressure hose fitting.)

### Roto-Couplings

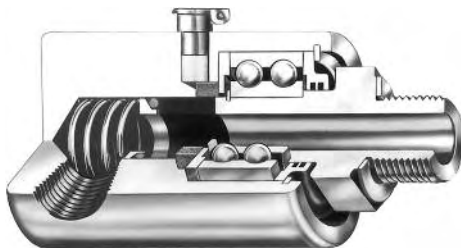

The Wichita Roto-coupling is a device to connect, or couple, a non-rotating air, gas, or fluid line to a rotating shaft.

- Long life, no maintenance
- Felt seal eliminates bearing contamination
- Fast, easy installation

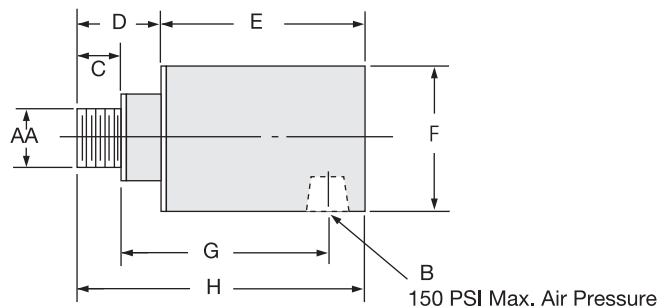

### Dimensions: inches

Wichita Part No.	AA	B	C	D	E	F	G	H	Max. RPM
8-240-701-003-1	5/8-18NF	1/4" NPT	.40	1.046	2.250	1.500	2.13	3.297	3,500
8-240-705-001-1	1"-14 NF	1/2" NPT	.75	1.250	3.188	2.500	3.00	4.438	3,500
8-240-708-001-1	1"-14 NF	3/4" NPT	.75	1.313	4.688	2.875	3.69	5.440	3,500
8-240-710-002-1	1-1/2"-12 NF	1" NPT	1.13	1.937	4.875	3.250	3.44	6.812	2,500
8-240-712-001-1	2"-12 NF	1-1/2" NPT	1.13	2.813	5.250	4.250	5.38	8.062	2,500
8-240-714-001-3	2" NPT	2" NPT	1.50	3.000	7.062	4.625	7.00	10.062	1,000
8-240-716-000-3	2-1/2" NPT	2-1/2" NPT	1.88	3.250	9.375	7.000	7.75	12.625	750

# Power Take-Off Clutches

## Superior Torque Control for Heavy Duty Diesel Engines

Wichita has instituted quality assurance procedures aimed at achieving the ultimate in product reliability and its Power Take-Offs represent industry's most advanced PTO design.

Two mechanically activated PTO's are now available in addition to the performance-proven Air Tube Disc Clutch PTO's. Complete clutch engagement of the mechanical PTO units is assured with each release of the hand lever due to the incorporation of a heavy-duty Fuller® "Solo" truck clutch. With its many outstanding features, the Fuller clutch used in the Wichita PTO prevents torsional vibration from damaging engine or transmission components, or causing spline wear. The result is superior Power Take-Off performance and durability!



### Mechanical Power Take-Off Clutches

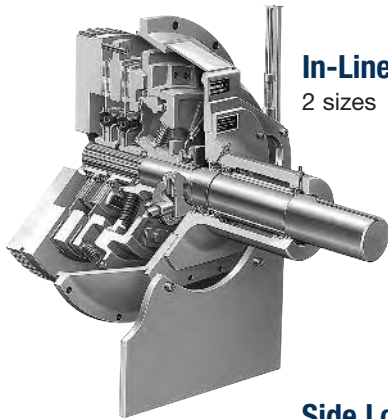

**In-Line PTO**  
2 sizes



**Side Load PTO**  
2 heavy duty models

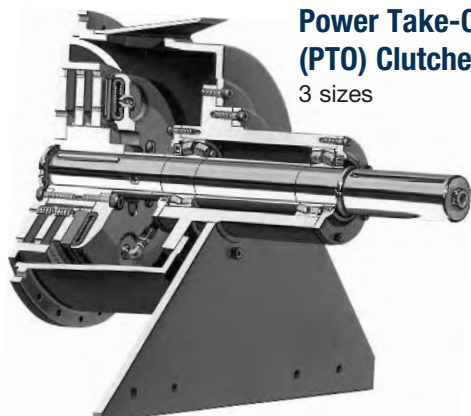

**Air-Tube Disc Power Take-Off (PTO) Clutches**  
3 sizes

### Typical Applications

The In-line PTO design provides direct drive operation with side load capability. It has an automatic self-adjusting feature and does not require a pilot bearing. Other features such as standard SAE flywheel mounting, interchangeable clutch and clutch housing, constant plate load and easy maintenance add up to superior performance.



Wichita 15-1/2" mechanical PTO provides long service life for Cummins 855 diesel on rock crusher.

Side Load PTO's utilize a pair of heavy-duty roller bearings fitted in to the shaft housing. The bearing support system eliminates the transmission of side loads that could reduce durability or even damage the engine's crankshaft. Its torque capacities range up to 420 HP @ 2100 RPM.



Wichita mechanical PTO handles shock and heavy loads for wood chippers.

Air-Tube Disc Power Take-Off Clutches provide dependable trouble-free performance on indirect drives with large overhung loads on engines of 250-700 HP. The Wichita design isolates the side load from the engine's crankshaft for long service life. Simple air controls can be utilized to remotely control the clutch as well as the throttle. Wichita PTO's have been successfully used for oil field, construction and marine applications.



Wichita PTO mounted on Caterpillar diesel engine.



# Power Take-Off Clutches

## Mechanical Design

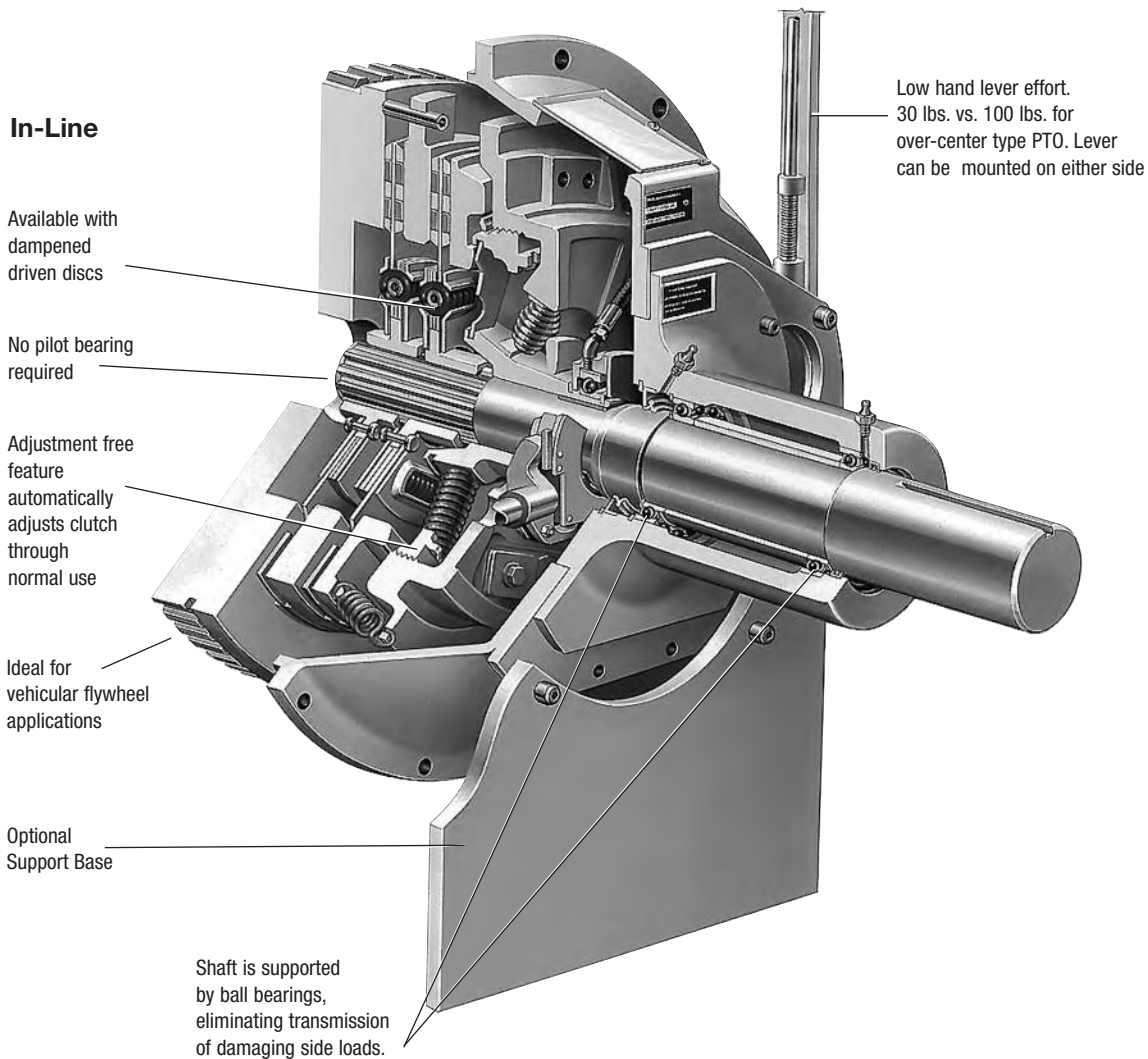

## Design Features

- Side Load version incorporates a rugged cylindrical roller bearing system which eliminates trouble-prone pilot bearings. Provides 100% external support of take-off shaft. Prevents transmission of side loads that fatigue or even damage the engine crankshaft.
- Precise alignment capabilities of the bearing system ensure flywheel/clutch concentricity to minimize effects of diesel engine torsional vibration.
- Performance-proven Fuller Solo Spring clutch provides easy engagement. Axial load is provided by three pairs of springs placed at an angle to the clutch centerline, reducing required axial force as the clutch is disengaged. The discs are raced with trapezoidal ceramic buttons, and are dampened with an assembly of coaxial springs mounted in the disc hub.
- Dampened clutch discs prevent torsional vibrations from damaging engine or components.
- Available in 2 sizes, from 14" to 15 1/2" for engines up to 420 HP @ 2100 RPM.

# Power Take-Off Clutches

## Mechanical In-line PTO (Truck Flywheel)

Size 14" Flat, 14" Pot & 15-1/2" Flat

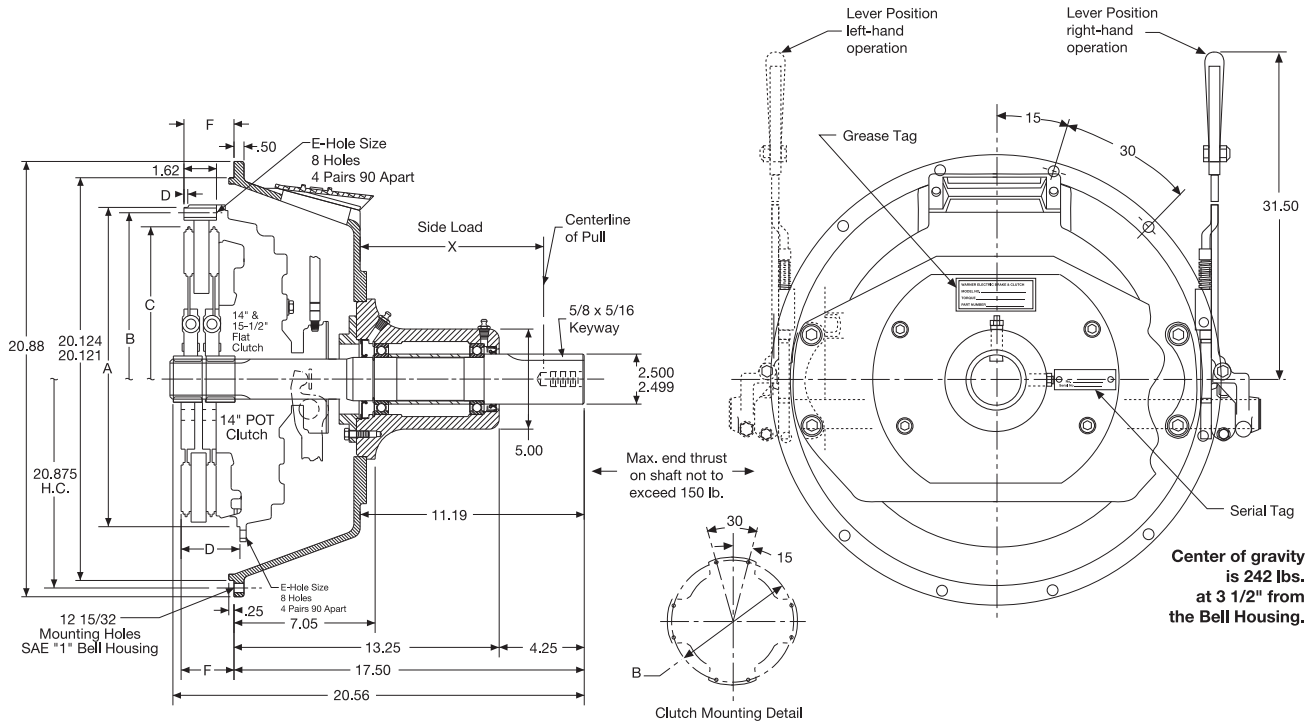

### Dimensions: inches

Clutch Size	SAE Bell Housing	A Pilot (+.000/- .002) in.	B Hole Circle	C Plate Dia.	D	E Hole Size - Qty	F
14" Flat	1	16.50*	15.500	13.56	N/A	13/32 8	2.62
14" Pot	1	14.750	15.500	13.75	2.94	13/32 8	2.50
15-1/2" Flat	1	17.155	16.625	15.22	0.19	15/32 8	2.50

\* Nominal diameter only, clutch is not piloted.

**Caution: Do not use with Drive Line**

Center of gravity is 242 lbs. located 3.50" from bell housing mounting surface

### Estimated Side Load Calculation

$$\#1 \quad L = \frac{126,000 \times \text{HP}}{N \times D} \times F \times \text{SF}$$

$$\#2 \quad L = \frac{1,945,000 \times \text{kW}}{N \times D} \times F \times \text{SF}$$

- L = Actual Applied Load (lbs. for #1 and kgs for #2)
- N = Shaft Speed (RPM)
- D = Pitch Diameter (in. for #1 and mm for #2) of Sheave
- F = Load Factor
  - 1.0 for Chain Drive or Gear Drive
  - 1.5 for Timing Belts
  - 2.5 for All V-belts
  - 3.5 for All Flat Belts

- SF = Service Factor
  - 2.1 for Reciprocating Compressors and other severe shock drives
  - 1.8 for Large Inertia Drives such as Crushers, Chippers, and Planers

### Allowable Side Load (lbs.) at 1,800 RPM

X Distance from Bell Housing	Side Load (lbs.) B <sub>10</sub> Bearing Life
3.62	1,600
4.62	1,100
5.62	850
6.62	680
7.62	565
8.62	450
9.62	400
10.26	370
11.25	340

At 2,100 RPM, derate side load by 20%.

**Note:** It is recommended that the optional support plate be used in side load applications.



# Power Take-Off Clutches

## Mechanical Side Load PTO (Truck Flywheel)

Size 15-1/2" Flat

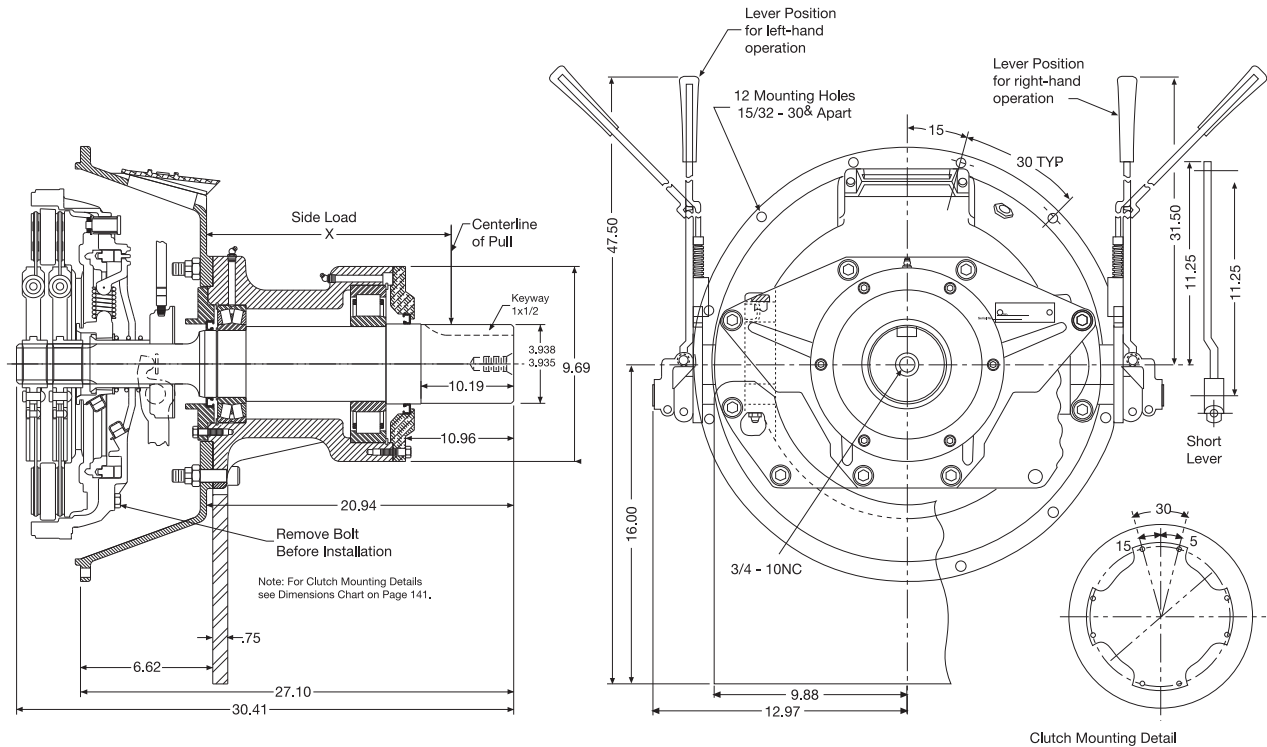

Clutch Mounting Detail

Clutch Size	Engine Manufacturers Common Truck Flywheels*		
	Caterpillar	Cummins	Detroit
14" Pot		FW1101	5129650 5101878
15-1/2" Flat	9N3136 4W6800	FW1134	5138863

\* Check with engine manufacturer for flywheel compatibility.

### Allowable Side Load (lbs.)

X Dimension	RPM				
	1000	1200	1800	2200	2400
11 in.	11,100	10,700	9,500	8,900	8,200
12 in.	10,000	9,500	8,500	8,000	7,400
13 in.	9,000	8,600	7,600	7,200	6,600
14 in.	8,200	7,800	7,000	6,500	6,100
15 in.	7,500	7,000	6,300	6,000	5,600
16 in.	7,000	6,600	5,800	5,500	5,300
17 in.	6,400	6,100	5,400	5,100	4,800
18 in.	6,000	5,700	5,000	4,700	4,400
19 in.	5,600	5,300	4,700	4,400	4,200
20 in.	5,400	5,200	4,500	4,200	4,000

### Engine Flywheel Housing SAE Standards

SAE Size No.	A in.	B in.	Bolt Circle		Tapped Holes	
			C in.	D in.	No.	Size
00	31.000/31.010	34-3/4	33-1/2	3-15/16	16	1/2-13
0	25.500/25.510	28	26-3/4	3-15/16	16	1/2-13
1/2	23.000/23.008	25-1/2	24-3/8	3-15/16	12	1/2-13
1	20.125/20.130	21-3/4	20-7/8	3-15/16	12	7/16-14
2	17.625/17.630	19-1/4	18-3/8	3-15/16	12	3/8-16
3	16.125/16.130	17-3/4	16-7/8	3-15/16	12	3/8-16
4	14.250/14.255	15-7/8	15	3-15/16	12	3/8-16
5	12.375/12.380	14	13-1/8	2-13/16	8	3/8-16
6	10.500/10.505	12-1/8	11-1/4	2-13/16	8	3/8-16

For flywheel standards consult the SAE standards manual.

**Note:** For mounting, use socket head capscrews conforming to the ASTM-574-97a. Support plate must be perpendicular to side load pull.

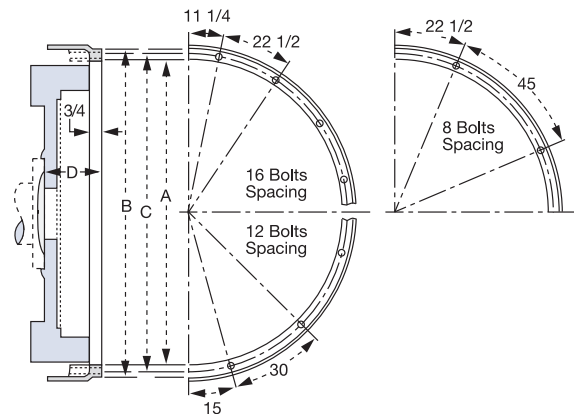

# Power Take-Off Clutches

## Specifications

Clutch Size	Torque* lb.in. (Nm)	Flywheel Bore Opening in.(cm)	Spline Dia. and Number of Splines in. - qty	Duty A to B <sup>1</sup> Light and Normal HP/100 RPM	Duty C to D <sup>1</sup> Heavy and Extra Heavy HP/100 RPM	Max. Speed RPM	Max. Slip Sec.
14" Flat (109504-10) Solo	10,800 (1,220)	7 (17.8)	2" - 10	17	13	2100	3
14" Pot <sup>3</sup> (108050-59) EP	16,800 (1,898)	7 (17.8)	2" - 10	27	20	2100	3
15-1/2" Flat (109701-74) Solo	19,800 (2,237)	8.5 (21.6)	2" - 10	32	20	2100	3
15-1/2" Flat HC** (109701-25) Solo	24,600 (2,779)	10 (25.4)	2" - 10	39	20	2100	3

\* On C & D duty applications, Clutch Torque must exceed Engine's Peak torque

\*\* 15-1/2" Flat, high capacity clutch model – available upon request.

## Power Take Off Chart

PTO Clutch	Flywheel Type	Type	SAE Bell Housing	Parts List Number	Drawing Number	Weight
14" Flat	Truck†	Inline	1	Available	Consult Factory	
14" Flat	Truck†	Inline	2	6-714-299-210-0	6-714-202-915-9	
14" Flat	Truck†	Side Load	1	6-714-299-211-0	6-714-202-916-9	
14" Flat	Truck†	Side Load	2	6-714-299-209-0	6-714-202-914-9	
14" Pot	Truck†	Inline	1	6-714-299-104-0	6-714-200-911-9	
14" Pot	Truck†	Inline	2	6-714-299-105-0	6-714-200-910-9	
15-1/2" Flat	Truck†	Inline	1	6-715-299-206-0	6-715-202-909-9	242 lbs.
15-1/2" Flat	Truck†	Inline	1	6-715-299-232-0	6-715-299-232-9	
15-1/2" Flat	Truck†	Inline	2	6-715-299-207-0	6-715-202-910-9	
15-1/2" Flat HC	Truck†	Inline	1	6-715-299-229-0	6-715-202-909-9	
15-1/2" Flat	Truck†	Side Load	1	6-715-299-208-0	6-715-202-912-9	
15-1/2" Flat	14" Industrial	Inline	1	6-715-299-209-0	6-715-202-913-9	340 lbs.
15-1/2" Flat	14" Industrial	Side Load	1	6-715-299-221-0	6-715-202-918-9	
15-1/2" Flat	18" Industrial	Side Load	0	See <sup>2</sup>	Consult Factory	

† Alternately referred to as a "Vehicular" flywheel.

Conversion Kits	Flywheels	SAE Bell Housing
8-560-320-017-0	15-1/2" Truck to 14" Industrial	1 to 1
8-560-320-073-1	15-1/2" Truck to 18" Industrial	1 to 0

## Mechanical Side Load PTO HP Rating based on side load using 12-1/2 P.D., 8-8V groove sheave at max. SF.

Speed	Bearing Carrier	Clutch Only
1,800	200 HP	360 HP
2,100	225 HP	420 HP

<sup>1</sup> See chart "A", on page 123.

<sup>2</sup> 15-1/2" Flat, Side Load PTO uses conversion kit 8-560-320-073-1.

<sup>3</sup> Old style flywheel, often not available on new engines.

See Engine manufacturer for flywheel availability.

## Estimated Side Load Calculation

$$\#1 \quad L = \frac{126,000 \times \text{HP}}{N \times D} \times F \times \text{SF}$$

$$\#2 \quad L = \frac{1,945,000 \times \text{kW}}{N \times D} \times F \times \text{SF}$$

L = Actual Applied Load (lbs. for #1 and kgs for #2)

N = Shaft Speed (RPM)

D = Pitch Diameter (in. for #1 and mm for #2) of Sheave

F = Load Factor

1.0 for Chain Drive or Gear Drive

1.5 for Timing Belts

2.5 for All V-belts

3.5 for All Flat Belts

SF = Service Factor

2.1 for Reciprocating Compressors and other severe shock drives

1.8 for Large Inertia Drives such as Crushers, Chippers, and Planers

# Power Take-Off Clutches

## Selection Example:

To properly select a Power Take Off (PTO), the following information is needed:

1. Power transmission type: Inline or Side Load
  2. Application engine horsepower @ speed
  3. Peak engine torque
  4. SAE bell housing size
  5. New engine installation or retrofit to an existing engine
  6. Duty selection: See chart "A", page 123  
Chart "A" gives application requirements ranging from "Light" to "Normal" duties (A to B) and "Heavy" to "Extra Heavy" duties (C to D)
  7. Inertia of machine/load
  8. Pitch diameters of drive and driven sheaves\*\*\*\*
  9. Width of drive sheave on Power Take Off shaft\*\*\*\*
- \*\*\*\* Not applicable to inline drives

## Machine Requirement:

Machine Required:	Mud Pump – Triplex piston type
Installation:	New engine installation
Power Transmission Type:	Side load
HP & Speed:	300 HP @ 1,800 RPM
Engine Peak Torque:	1,120 lb.ft.
SAE Bell Housing Size:	SAE bell housing 1
PD* Driver Sheave on PTO:	12.5 in.
PD* Driven Sheave on Mud Pump:	15.0 in.
Width of Driver Sheave on PTO:	9-3/8 in. (8 grooves – 8V section Belt Sheave**)
WR <sup>2</sup> – Inertia of Pump:	108 lb.ft. <sup>2</sup>

\* PD is Pitch Diameter of sheave/pulley.

\*\* See manufacturer for sheave details.

## Calculations:

$$1. \text{ Application Torque} = \frac{\text{HP} \times 63,000/\text{RPM}}{300 \times 63,000/1,800} = \text{lb.in.} = 10,500 \text{ lb.in.}$$

$$2. \text{ Engine Peak Torque} = \frac{\text{lb. ft.} \times 12}{1,120 \times 12} = \text{lb.in.} = 13,440 \text{ lb.in.}$$

$$3. \text{ Mud Pump's Speed} = \frac{\text{Engine Speed} \times \text{P.D. of PTO's sheave}}{\text{P.D. of Mud Pump's sheave}} = \text{RPM}$$

$$1,800 \times 12.5/15 = 1,500 \text{ RPM}$$

$$4. \text{ Reflect Pump's inertia up to PTO's shaft} = \text{Pump's Inertia} \times \left( \frac{\text{Pump's speed}}{\text{PTO's speed}} \right)^2 = \text{lb.ft.}^2$$

$$108 \times \left( \frac{1,500}{1,800} \right)^2 = 75 \text{ lb.ft.}^2 @ 1,800 \text{ RPM}$$

$$5. \text{ PTO's clutch slip time, (sec.)} = \frac{\text{WR}^2 \times \text{PTO's speed}}{25.6 \times \text{Application Torque}}$$

$$= \frac{75 \times 1,800}{25.6 \times 10,500} = 1/2 \text{ sec.}$$

$$6. \text{ Estimate Side Load, (lbs.)} = \frac{\text{HP} \times 378,000}{\text{Engines Speed} \times \text{PTO's sheave PD}}$$

$$\frac{300 \times 378,000}{1,800 \times 12-1/2} = 5,040 \text{ lbs.}$$

## How to Select:

### Part 1. PTO Clutch Calculation Follows:

1. Select clutch duty from field of application = Reference chart "A", page 123, Petroleum production shows Mud Pump under duty "D"
2. Determine required HP/100 RPM duty capacity = Application torque/630 = HP/100 RPM  
 $10,500/630 = 16-2/3 \text{ HP/100 RPM}$
3. Select clutches based on duty = On clutch capacity chart, page 149, shows the following clutches have sufficient capacity.  
14" Pot, 15-1/2" Flat & 15-1/2" Flat HC  
a.) This is a new engine installation and Note 3 states that there may be an availability problem with the 14" Pot style clutch.  
b.) There is not an advantage in capacity to warrant the use of the 15-1/2" Flat HC style clutch. Therefore, preliminary selection of the clutch is the 15-1/2" Flat style clutch.
4. Peak torque verses clutch torque = On "C" and "D" duty applications, it is required that the clutch torque is greater than engine's peak torque.  
15-1/2" Flat clutch torque from clutch specifications chart on page 149 is 19,800 lb. in.  
Engine's peak torque is 13,440 lb.in.  
Clutch torque > Engine's peak torque  
19,800 lb.in. > 13,440 lb.in.
5. Speed = Clutch capacity chart shows that it has a speed limit of 2,100 RPM which is greater than the required speed of 1,800 RPM.
6. Clutch slip time, (sec.) = Clutch capacity chart shows maximum clutch slip time as 3 sec. which is greater than the calculated 1/2 seconds.

### Part 2. Side Load Calculation Follows:

- Center of sheave's side pull =  
Sheave width/2 = (9-3/8)/2 = 4-11/16 in.
- Locate dimension from Bell housing to shaft's end = 20-15/16 in.  
Reference specific PTO drawing  
15-1/2" Flat PTO side load, page 148.
- Determine "X" distance on PTO =  
(Bell hsg. to shaft's end dim.) - (Center of sheave's side pull)  
(20-15/16) - (4-11/16") = 16-1/4 in.  
Round "X" distance to the nearest whole number = 16 in.
- Look up side load =  
Check side load at PTO's speed and "X" distance  
Page 148, allowable side load.  
At "X" distance of 16 in. and 1,800 RPM, chart yields a side load capacity of 5,800 lbs.
- Comparison on side load =  
Side load capacity > Required side load  
5,800 lbs. > 5,040 lbs.

## Final Selection:

15-1/2 in. Flat power take off,  
Side load version with SAE "1" Bell Housing  
Power take off chart, page 149, lists the associated parts lists and drawings.

Parts Lists Number = 6-715-299-208-0  
Drawing Number = 6-715-202-912-9



# Power Take-Off Clutches

## Air-Tube Disc Design (Industrial)

Ideal for automatic controls

Disc design provides smooth shock-free start-ups

High-speed air tube not affected by centrifugal force

No O-rings or diaphragms to wear out

Bearing support eliminates sideload on crankshaft

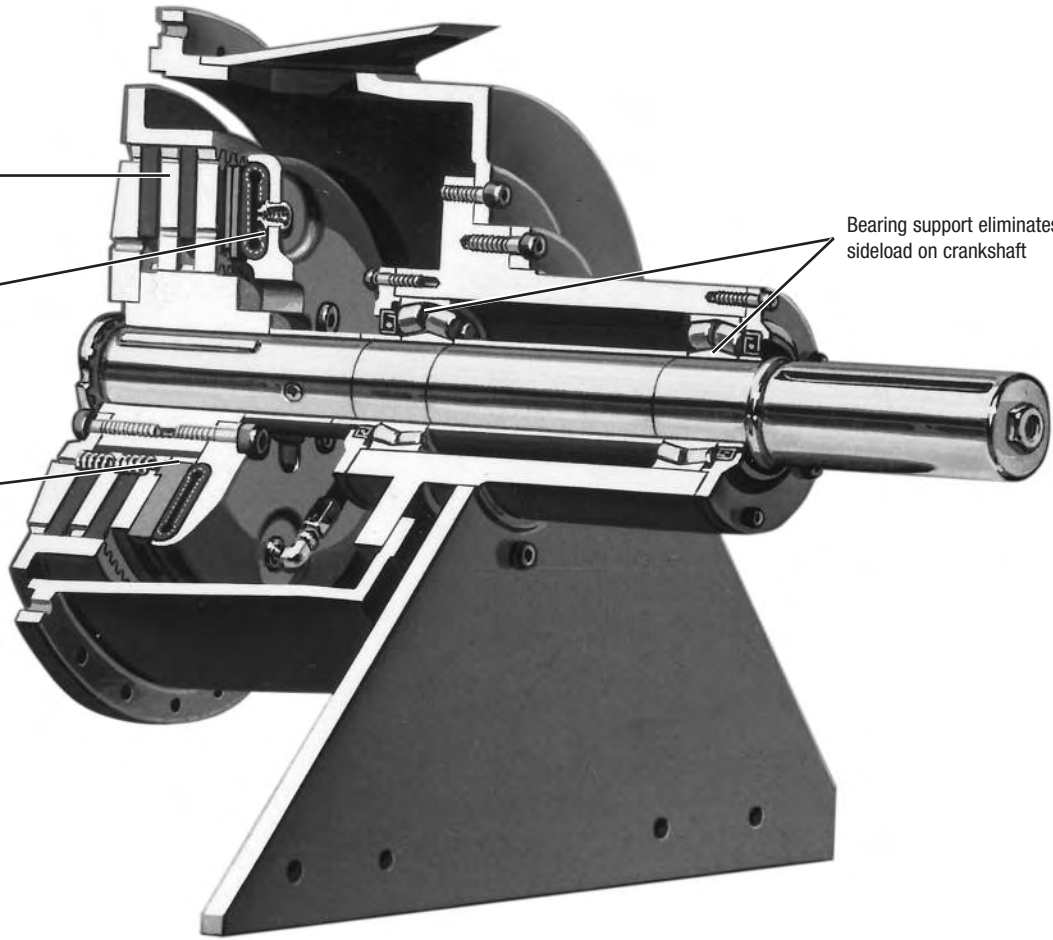

### Design Features

- Disc design provides smooth, shock free start-ups.
- Air activated-ideal for automatic or remote controls.
- Bearing support eliminates sideload on crankshaft.
- High speed air tube not affected by centrifugal force.
- No O-rings or diaphragms to wear out.
- Dynamically balanced for high speed operation.
- Models available for all popular diesel engines. Up to 700 HP capacity.

### Typical air control system

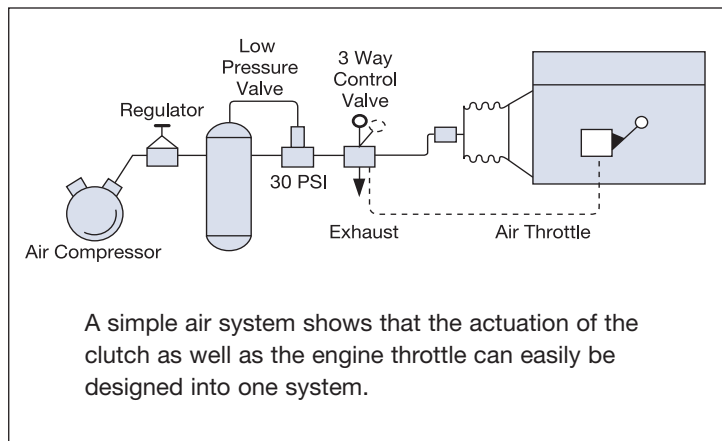

# Power Take-Off Clutches

## Air Tube Disc Side Load PTOs

Type A

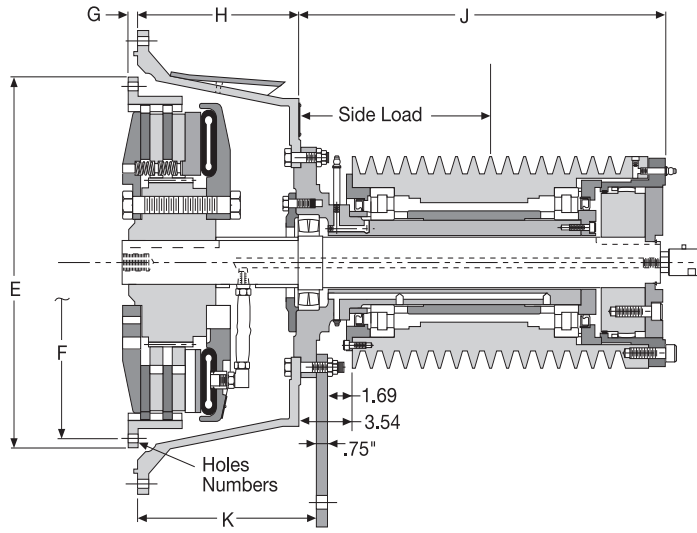

Type B

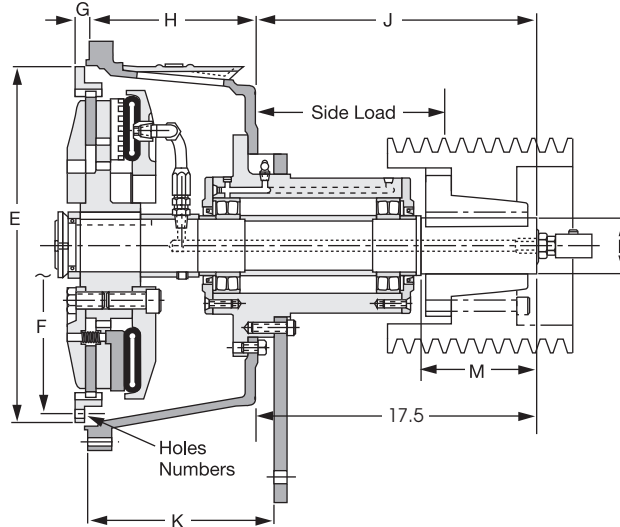

Type C

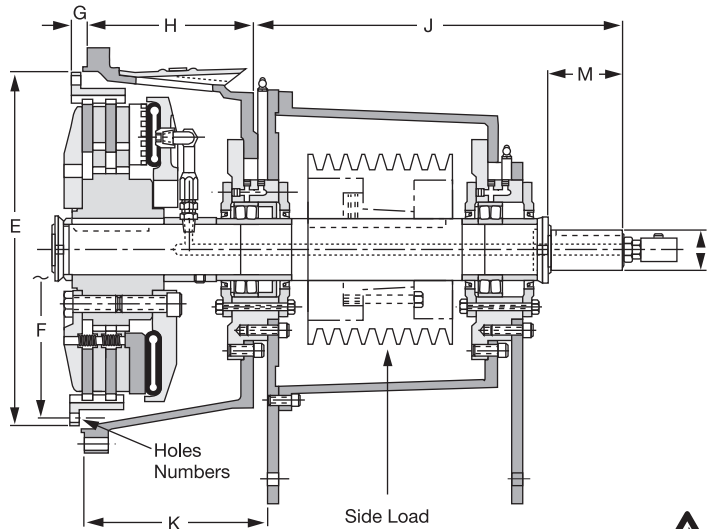

# Power Take-Off Clutches

## Dimensions and Specifications: inches

Parts List No.	Clutch Size	SAE No.	Type	E +- .000						L +.000 -.002		Holes No.	Keyway	No. & Type of Grooves	P.D. of Sheave	
				F	G	H	J	K	M							
6-715-204-302-0	214H	1	B	18.375	17-1/4	1.000	10-13/16	17-17/32	11-25/32	3.625	7-1/4	17/32	8	7/8 X 7/16	—	—
6-715-204-303-0	214H	1/2	B	18.375	17-1/4	1.750	10-13/16	17-17/32	11-1/32	3.625	7-1/4	21/32	6	7/8 X 7/16	—	—
6-715-204-304-0	214H	0	B	18.375	17-1/4	1.000	10-13/16	17-17/32	11-25/32	3.625	7-1/4	21/32	6	7/8 X 7/16	—	—
6-715-204-306-0	214H	1	C	18.375	17-1/4	1.000	10-13/16	23-15/16	11-13/16	2.500	4-5/8	17/32	8	5/8 X 5/16	8-"8V"	12.3
6-718-104-307-0	118	1/2	B	22.498	21-3/8	1.000	10-5/8	17-17/32	11-25/32	3.625	7-1/4	21/32	6	7/8 X 7/16	—	—
6-718-104-302-0	118	0	B	22.498	21-3/8	.625	10-13/16	17-17/32	11-25/32	3.625	7-1/4	21/32	6	7/8 X 7/16	—	—
6-718-104-306-0	118	0	A	22.498	21-3/8	.625	8-51/64	20-1/2	10-7/64	—	—	21/32	6	—	10-"8V"	15.2
6-718-104-304-0	118	0	A	22.498	21-3/8	.625	8-51/64	20-1/2	10-7/64	—	—	21/32	6	—	10-"D"	15.2
6-718-104-303-0	118	1/2	A	22.498	21-3/8	1.000	10-5/8	23-15/16	11-25/32	—	—	21/32	6	—	16-"8V"	12.5
6-718-104-305-0	118	0	A	22.498	21-3/8	.625	10-13/16	23-15/16	11-25/32	—	—	21/32	6	—	16-"8V"	12.5
6-718-104-301-0	118	1/2	A	22.498	21-3/8	1.000	10-5/8	23-15/16	11-25/32	—	—	21/32	6	—	20-"5V"	12.5
6-718-204-307-0	218	1/2	B	22.498	21-3/8	1.000	10-5/8	17-17/32	11-25/32	3.625	7-1/4	21/32	6	7/8 X 7/16	—	—
6-718-204-308-0	218	0	B	22.498	21-3/8	.625	11-3/16	17-17/32	12-5/32	3.625	7-1/4	21/32	6	7/8 X 7/16	—	—
6-718-204-303-0	218	1/2	A	22.498	21-3/8	1.000	10-5/8	23-15/16	11-25/32	—	—	21/32	6	—	16-"8V"	12.5
6-718-204-304-0	218	1/2	C	22.498	21-3/8	1.000	10-5/8	23-15/16	11-13/16	2.500	4-5/8	21/32	6	5/8 X 5/16	8-"8V"	12.3
6-718-204-301-0	218	0	A	22.498	21-3/8	.625	10-13/16	23-15/16	11-25/32	—	—	21/32	6	—	16-"8V"	12.5
6-718-204-306-0	218	0	C	22.498	21-3/8	.625	10-13/16	23-15/16	11-13/16	2.500	4-5/8	21/32	6	5/8 X 5/16	8-"8V"	12.3
6-718-304-300-0	318	0	B	22.498	21-3/8	.625	12-3/8	17-17/32	13-19/32	3.625	7-1/4	21/32	6	7/8 X 7/16	—	—

Note: For standard SAE engine flywheel dimensions see page 142.

## Allowable Side Load (lbs.) at 1,800 RPM

Type A	Distance X from base mount-in.	Load lb.	Distance X from base mount-in.	Load lb.
	0	—	14	8,900
	4	5,400	16	7,100
	6	6,300	18	6,000
	8	7,500	20	5,100
	10	9,200	22	4,400
	12	12,000	24	4,300

Note: Derate by 20% for 2,100 RPM.

Type B	Distance X from base mount-in.	side load lb.	Distance X from base mount-in.	Load lb.
	—	—	12	4,400
	4	11,500	13	4,100
	5	9,600	14	3,800
	6	8,200	15	3,600
	7	7,200	16	3,400
	8	6,400	17	3,200
	9	5,800	18	3,000
	10	5,200	19	2,900
	11	4,800	20	2,800

Note: Derate by 20% for 2,100 RPM.

## Type C 6,500 lb. Max. side load.

Note: Derate by 20% for 2,100 RPM.

## Clutch Specification Table

Clutch Model	Recommended Maximum PTO HP/100 RPM	Clutch Siip Torque lb.in. at 100 PSI .3 CF.*	Recommended Maximum PTO HP/100 RPM With Heavy Duty Friction Disc
214H	18	71,600	23
118	21	64,500	27
218	42	129,000	54

\* Recommend only 25% of rated torque on PTO's (in.lbs.) - 30% with heavy duty disc.

Note: For mounting, use socket head capscrews conforming to the ASTM-574-97a. Support plate must be perpendicular to sideload pull.

## Estimated Side Load Calculation

$$\#1 \quad L = \frac{126,000 \times \text{HP}}{N \times D} \times F \times \text{SF}$$

$$\#2 \quad L = \frac{1,945,000 \times \text{kW}}{N \times D} \times F \times \text{SF}$$

L = Actual Applied Load (lbs. for #1 and Kgs for #2)

N = Shaft Speed (RPM)

D = Pitch Diameter (in. for #1 and mm for #2) of Sheave.

F = Load Factor

1.0 for Chain Drive or Gear Drive

1.5 for Timing Belts

2.5 for All V-belts

3.5 for All Flat Belts

SF = Service Factor

2.1 for Reciprocating

Compressors and other severe shock drives

1.8 for Large Inertia Drives such as Crushers, Chippers, and Planers

# Mesur-Fil Fluid Couplings

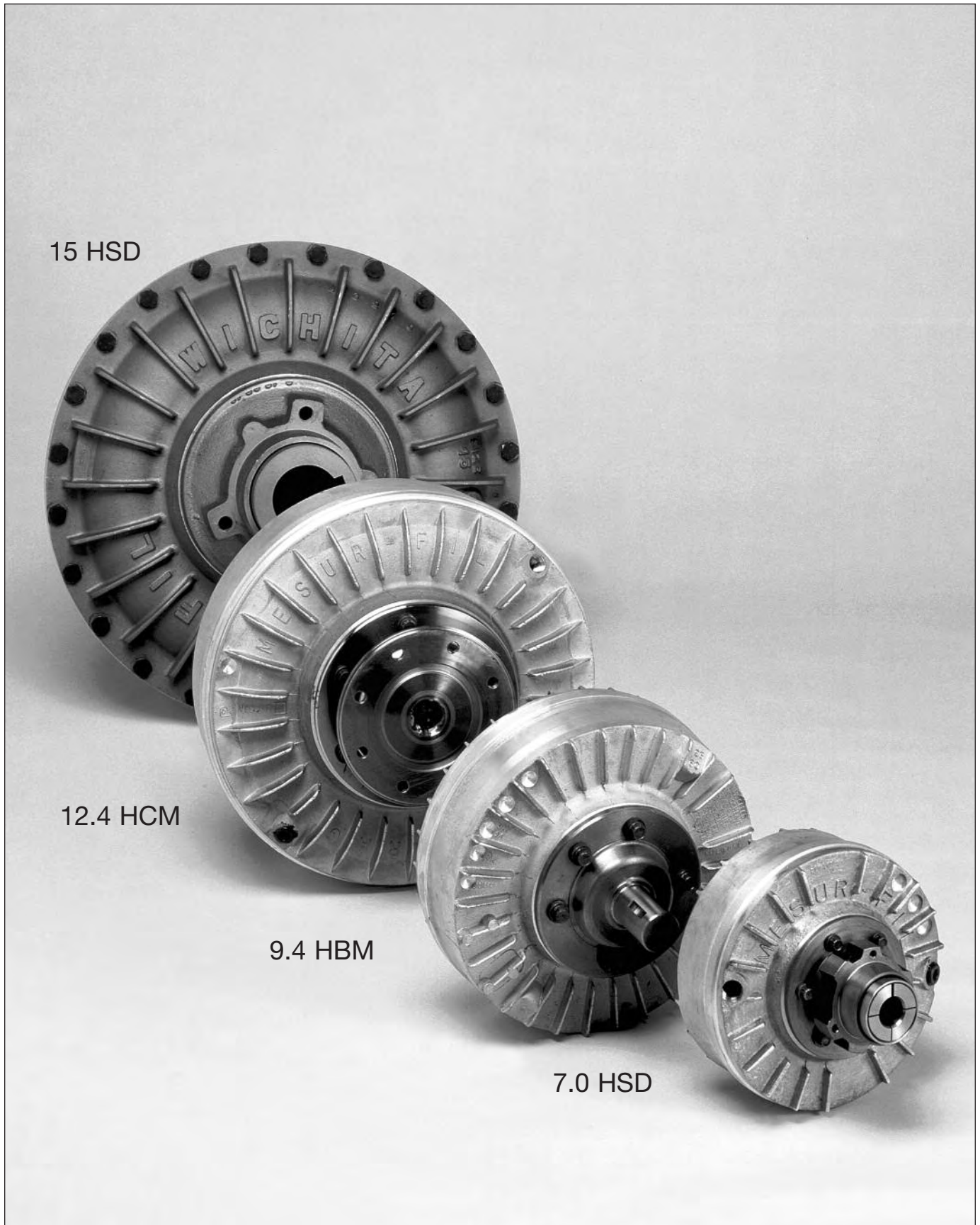

## Wichita Mesur-Fil® Fluid Couplings

deliver reliable smooth power transmission. To consistently deliver, we select only from the highest quality materials. Our manufacturing and product assembly are completed under the most exacting guidelines and established procedures. The result is unquestioned consistent product dependability.

Mesur-Fil Fluid Couplings are rated for motors up to 2,500 HP. They have earned a reputation for providing smooth, soft starts while reducing current draw on the motor by 33%.

Mesur-Fil Fluid Couplings are ideally suited for direct drive applications between electric motors and gear boxes.

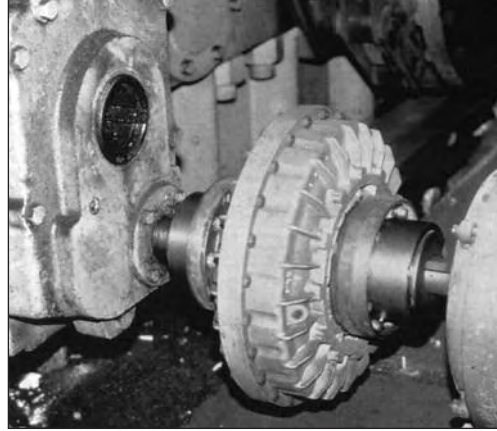

## Typical Applications

### Bulk Material Handling Equipment and Mining Related Industries:

- Conveyors of all types
- Crushers
- Excavators
- Fans
- Mills
- Mixers
- Pumps
- Screening Plants

### Petrochem and Chemical Processing:

- Agitators
- Blowers/Fans
- Centrifuges
- Compressors
- Mixers
- Pumps

### Other Applications include:

- Amusement park rides
- Construction
- Machine tools
- Oil Field
- Power Generation
- Ski resort chair lifts



Mesur-Fil 7.0 HSD allows shock-free acceleration on large inertia loads.

Picture Courtesy of Torpey Denver, Inc.



Mesur-Fil 7.0 HSD on amusement park ride, "Speed Boats," giving cushioned, smooth starts.

Picture Courtesy of Torpey Denver, Inc.

# Mesur-Fil Fluid Couplings

## Design Advantages

Mesur-Fil Fluid Couplings allow motors to start unloaded and to reach operating speed with smooth, controlled acceleration. This makes it ideal for applications with high inertia loads. They are available in either constant or delay fill versions.

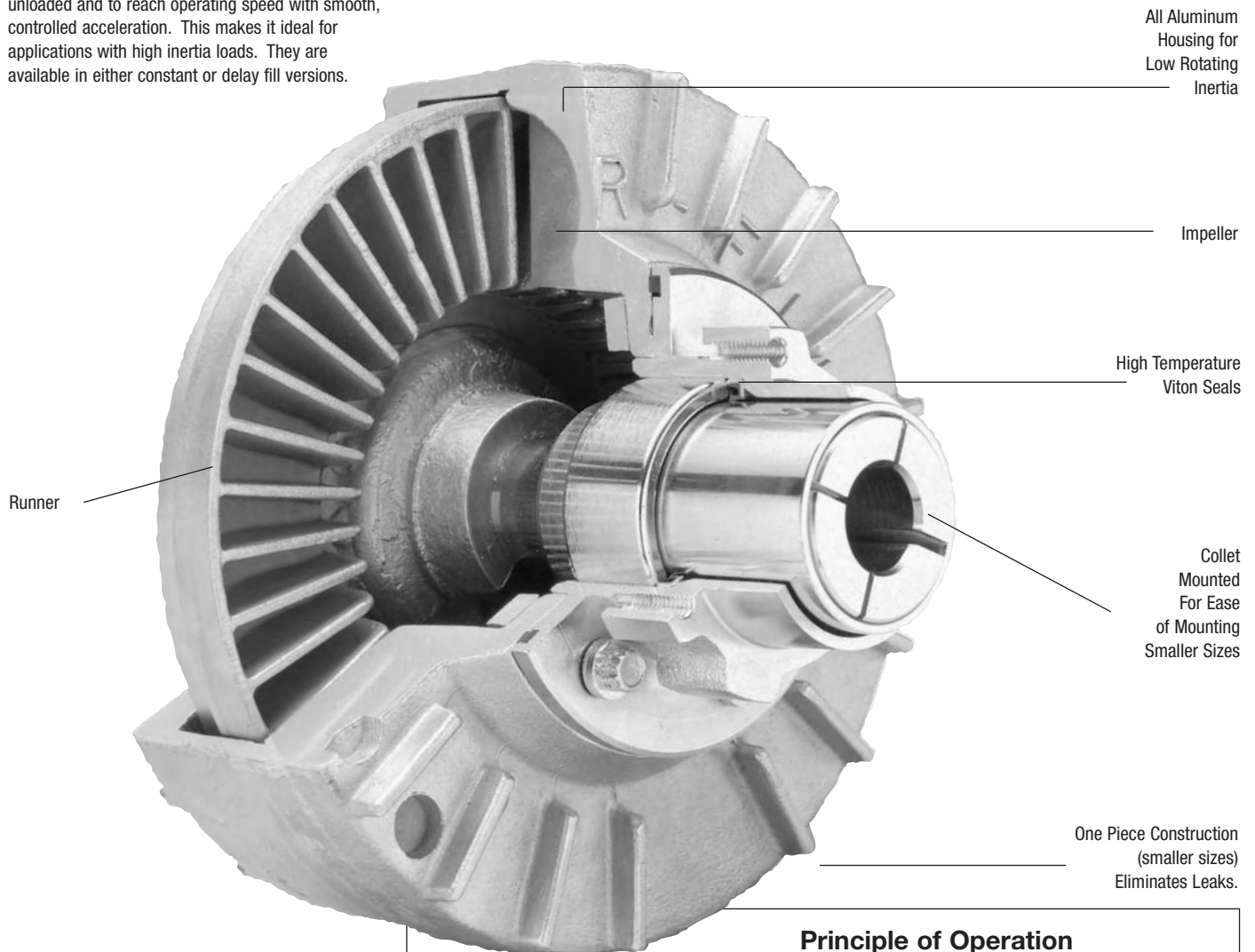

## Benefits

Mesur-Fil Fluid Couplings offer several advantages:

- Reduced energy consumption
- Jam/overload protection
- Shock load cushioning
- No metal-to-metal contact
- Wide range of available mounting options
- High temperature Viton seals
- Available from over 700 Formsprag Authorized Distributors.

## Principle of Operation

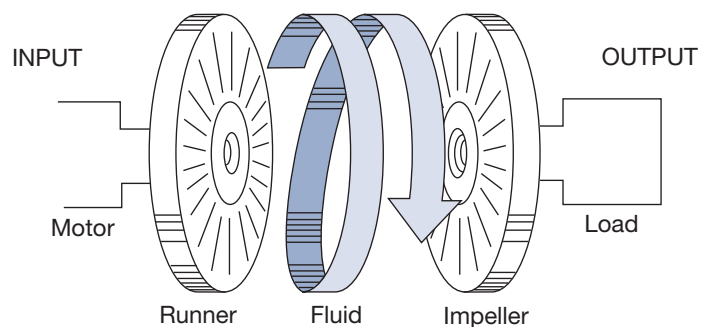

There are three primary components to Mesur-Fil Fluid Couplings:

1. Vaned runner
2. Vaned impeller
3. Fluid fill

Torque, produced by the prime mover (motor) acting on a vaned runner, is transmitted through the flow of fluid into

the chambers formed by the two coupling halves. The oil (fluid) is subsequently thrown into the vaned impeller connected to the load causing it to turn. It is important to note, that as this transmission of power takes place, there is virtually no wear on the transmitting parts because there is no mechanical contact between them.

## Fluid Requirements

Figure 2 reveals a typical NEMA B electric motor torque curve together with the particular operating characteristics of a specific coupling with a designated fill level. With no power supplied, all of the fluid is settled at the bottom of the coupling. Slip rate in this condition is 100% with the input free to turn. With the motor starting and increasing in speed to the breakdown point, torque builds in the coupling. As torque increases, the coupling begins to deliver the load to the motor, eventually bringing the load up to speed (refer to the load acceleration area in Figure 2).

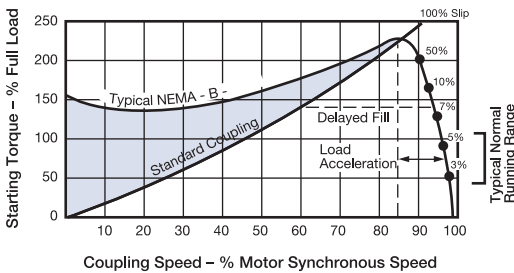

Figure 2 - Starting Torque

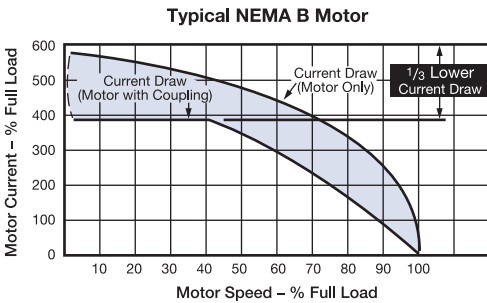

Figure 3 - Start-up Burnout Protection

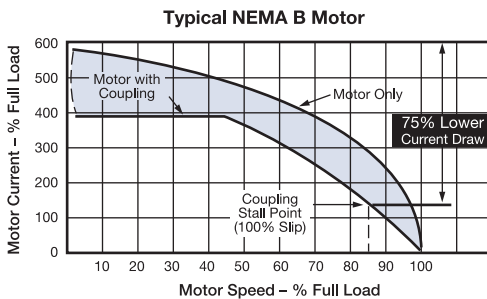

Figure 4 - Jam Load Burnout Protection

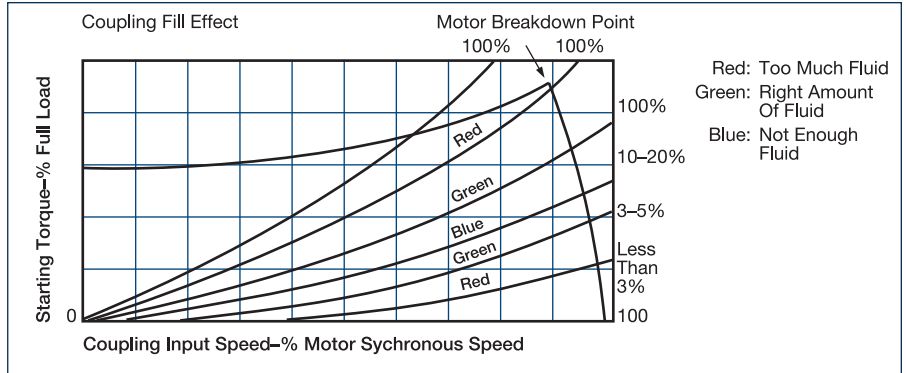

Figure 1 - Motor Breakdown Points

The area on the chart between the motor torque curve and the 100% slip curve represents the excess torque available to the motor to start itself without also having to start the load. It is this operating characteristic which permits a soft start with a one-third lower current draw on the motor (see Figure 3). (It should be noted that because the coupling torque can only be developed if the runner is turning at a slower speed than the impeller, an ideal small amount of slip of 3% to 5% is necessary).

The Mesur-Fil Fluid Coupling provides for jam load protection to the motor and other vital power system components. It is designed to allow the motor to decelerate only to its breakdown point (see Figure 4). The results without the fluid coupling could be a locked rotor condition, resulting in excessive current draw and potential motor damage. Additionally, the coupling distributes the shock of an overload over a longer time span, thus reducing the possibility of damage.

## Delayed Fill

Mesur-Fil Fluid Couplings, sizes 15 through 34 (30 to 1500 HP), have an available delayed fill option restricting starting torque to 140% of full load while still ensuring low slip at full speed. The result is a softer, more gradual start which can be advantageous for applications such as belt conveyors and mixers.

The operating principles are simple. With the idle coupling (see Figure 5) the purpose of the delayed fill chamber is to isolate a portion of the fluid from the main coupling. As the runner accelerates (see Figure 6), the chamber attached to the runner gradually releases fluid into the main coupling through specially calibrated orifices. The fill increases proportionally with the output speed. With acceleration complete (see Figure 7) at the high speed running position, almost all of the fluid has been released from the chamber into the coupling, giving the coupling high fill/low slip characteristics.

Figure 5 Standstill

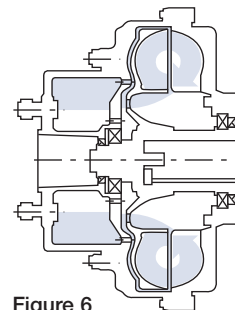

Figure 6 Accelerating

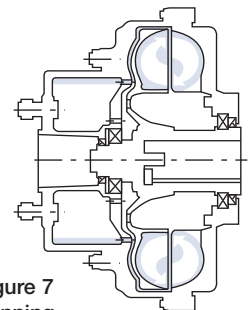

Figure 7 Running

# Mesur-Fil Fluid Couplings

## Mounting Types per Size

Mounting Type	Size											Mounting Application	
	7.0*	9.4*	12.4*	15	17	19	21	24	27	29	34		
<b>HC</b> (page 168)	•	•	•										Basic coupling for custom input & output
<b>HCM</b> (pages 170-171)	•	•	•	•	•	•	•	•	•	•	•	•	For use with flexible gear couplings
<b>HBM</b> (page 169)	•	•	•										Shaft to shaft applications For stub shaft input/output sizes 7-12.4
<b>HSD</b> (pages 172-173)	•	•	•	•	•	•	•	•					Parallel, QD sheave application

\* Modular design (See page 167)





**HC Sizes 7.0-12.4 Input and Output customer supplied.**  
(page 168)

This is a basic coupling with an input bore for direct mounting on the motor shaft end and a convenient bolt circle for customer-designed output configurations.

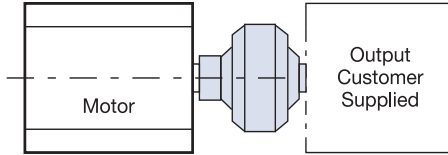

**HCM**  
(pages 170-171)

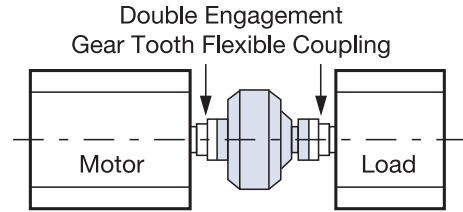

The Model HCM Fluid Coupling is a complete unit with both input and output flanges. It is intended for installation between two halves of a double engagement gear tooth flexible coupling which is customer supplied. This arrangement provides for a wide range of input and output configurations for ease of installation.

**HBM Sizes 7-12.4**  
(page 169)

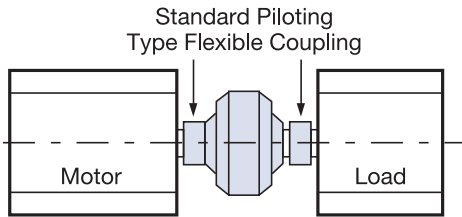

This coupling is a complete unit with straight input and output shaft. It is installed between two piloting type flexible couplings supplied by the customer.

**HSD**  
(pages 172-173)

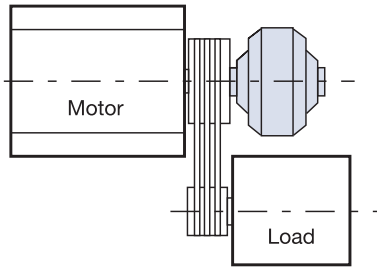

Hydro-sheave couplings are mounted to the motor shaft end and provide minimal overhung loads for parallel (belt-driven) shaft applications. The smaller sizes (7-12.4) are installed very quickly and easily utilizing a slotted collet in which no drilling or tapping is required. The slotted collet is finished bored to fit standard NEMA B motor shaft dimensions. The larger sizes (15-24) are installed with a center locating bolt that does require drilling and tapping to ensure proper mounting. The Model HSD Fluid Coupling consists of a basic fluid coupling, input and output group, and a standard customer supplied QD type sheave. The sheave is mounted on a coupling that has been installed on the end of a driveshaft.

# Mesur-Fil Fluid Couplings

## Selection and Sizing

### Fill Levels (NEMA B Motors)

The Quick Selection Chart (see Figure 8) provides the correct size coupling and fill level for any standard NEMA B motor within the Mesur-Fil range. It also provides the slip rate that can be anticipated at normal operating speed. Having the correct amount of oil in the coupling is extremely critical to ensure safe and proper operation. Figure 9 shows the effects of either too much or too little fluid. With an optimum amount of fluid, the breakdown point of the motor with the 100% slip line of the coupling provide the best combination of soft start with slip rate at normal speed. With too much fluid (red area), the slip rate is lower and the start is harder. With too little fluid (blue area), the start will be softer but the slip rate will be much higher. This can cause heat dissipation problems, and, in extreme situations, the coupling may completely fail to move the load.

A choice of fluids is also available. In a normal environment, petroleum oil is the best fluid to use. For hazardous conditions such as those encountering dust, paint spray, etc., a special fire-resistant fluid may be required.

### Delay chamber is recommended for the following applications:

- Overland conveyors
- Blowers/Fans
- Mixers
- Crushers
- Excavators
- Mills
- Large inertia drives
- Centrifuges

Figure 8 Quick Selection Chart

HP	1200 RPM			1800 RPM			HP	KW
	Cplg. Size	Fill No.	% Slip	Cplg. Size	Fill No.	% Slip		
1/2	7.0	12	6	7.0	8	3	1/2	0.38
3/4	9.4	8	3	7.0	8	4	3/4	0.56
1	9.4	8	3	7.0	9	4	1	0.75
1 1/2	9.4	8-1/2	3	7.0	11	5	1-1/2	1.1
2	9.4	9	4	7.0*	12	6	2	1.5
3	9.4	10	5	9.4	8	2	3	2.2
5	12.4	7	3	9.4	8-1/2	3	5	3.8
7 1/2	12.4	8	2-1/2	9.4	9	3	7-1/2	5.6
10	12.4	9	4	9.4	10	4-1/2	10	7.5
15	12.4	11	5	12.4	7	3	15	11.3
20	15	2	3-1/2	12.4	8	2-1/2	20	15.0
25	15	2	5	12.4	8-1/2	3	25	18.8
30	15	1	4 1/2	12.4	9	3-1/2	30	22.5
40	15	0	5 1/2	12.4	10	4	40	30.0
50	17	1-1/2	4	12.4	11	5	50	37.5
60	17	1	4	15*	3	3	60	45.0
75	19	2	4-1/2	15	2	3-1/2	75	56.3
100	21	1/2	3-1/2	15	0	3-3/4	100	75
125	21	1-1/2	4-1/2	17	2	3	125	94
150	24	2	2-1/2	17+	2	4	150	113
200	24	2	3-1/2	19+*	2	3-1/2	200	135
250	24	1	4	19+* or 21*	0 or 2	3-1/2 or 2	250	188
300	27	1		21+*	2	3	300	225
350	27	0		21+*	1	3	350	263
400	29	1		24	3		400	300
450	29	1		24	2		450	338
500	29	1		24	2		500	375
600	29	0		27	2		600	450
700	29	0		27	1		700	525
800	29	0		27	0		800	600
900	34	1						
1,000	34	1						
1,250	34	0						
1,500	34	0						

Figure 9 Coupling Fill Effect

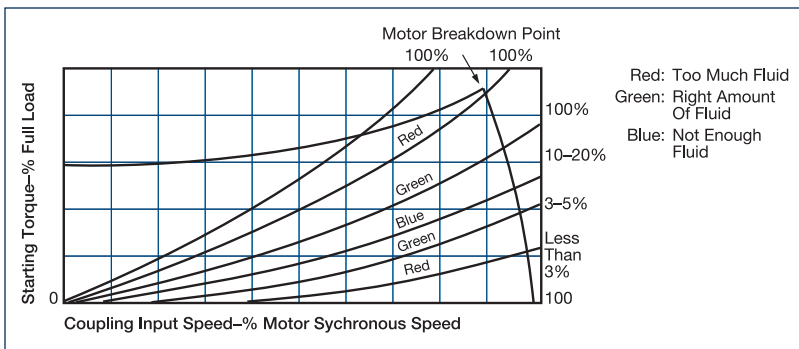

\* In these applications, coupling will develop stall torque somewhat higher than motor breakdown torque.

+ In these applications, frequent starts or overloads may overheat coupling. Use only for loads at or below rated torque of motor with infrequent starts.

• **Caution!** 7% or higher slips may cause overheating if coupling is cycled too rapidly.

For minimum operating temperature below -10° F, consult the factory.

**Note:** For vertical mounting order unit with both the standard and optional fill plugs on both sides of the unit.

## Input speed vs. Horsepower Graph

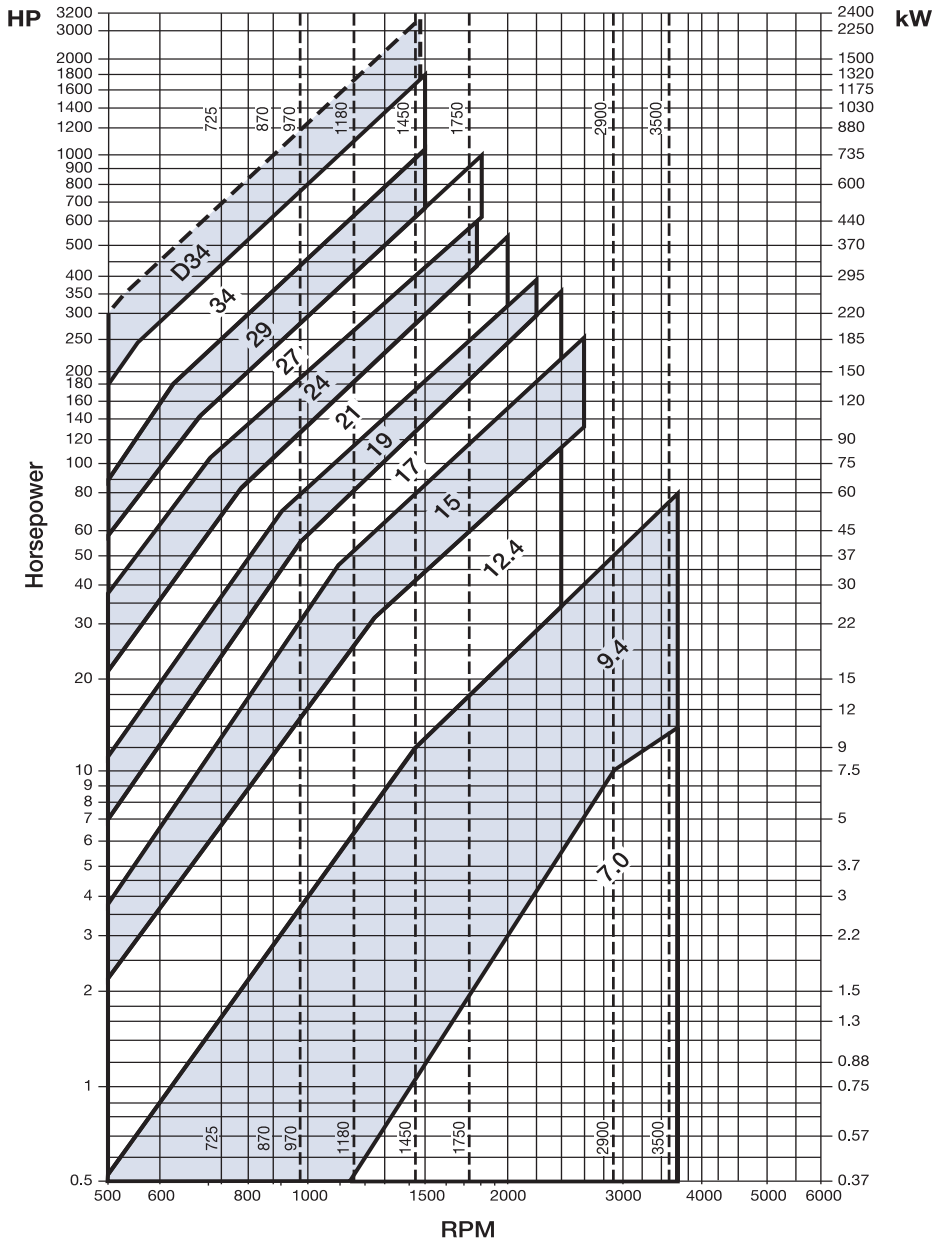

## Fluid quantities (fluid ozs.)

Fluid Quantities (U.S. Fluid Ounces)						
Fill Number						
Size	7	8	9	10	11	12
7.0		18.5	21	23	25.5	27.6
9.4		43	49	54	60	65
12.4	87	100	112	125	138	150

Fluid Quantities (U.S. Quarts)					
Fill Number					
Size	0	1	2	3	4
15	8	7.6	7.0	6.3	5.7
17	12.4	11.5	10.6	9.6	8.7
19	15	14	13	11.8	10.6
21	20	18.8	17.3	15.8	14.3
24	30	28	26	23.9	21.7
27	47	43.3	40.2	36.5	32.8
29	52	48.4	44.7	40.7	36.5
34	87.2	81	74.6	70	66

Delayed Fill			
Size	2	3	4
15	9.1	8.1	6.8
17	14.4	13.5	12.4
19	17.2	16.1	14.8
21	24.3	22.5	20.4
24	33	30.2	27.5
27	52.8	49.1	45.4
29	66.6	62.3	57
34	91.1	84.5	78.6

## Fluid Recommendation

**OIL: SAE 10W (Spec. MIL-L-2104 B)**  
 Chevron: Hydraulic Oil EP 32      Shell: Tellus 32  
 Esso: Nuto H 32                      Texaco: Rando HD 32  
 Mobil: DTE 24                          Total: Azolla ZS 32

### FIRE RESISTANT FLUID

Fyrquel: 220

## Overload Protection

### Fusible plug

In overload conditions, as the slip increases and the oil temperature rises, seals become damaged and begin to leak. In order to avoid this damage, in critical applications, it is advisable to install a fusible plug instead of a solid plug. Overload protection. For sizes 7.0 to 12.4 a 250° F fusible plug is available only as an option. For sizes 15 to 34 a 290° F fusible plug is standard. (A 250° F or 350° F fusible plug is available as an option.)

### Fusible pin For sizes 15-34

It's possible to avoid loss of oil from the unit by fitting a fusible pin. When temperature increases, reaching melting point of fusible element, a pin is released and touches a cam mounted on a relay which gives an alarm or switches off the electric motor. Like the fusible plug there are three different fusible elements. This solution needs only the replacing of the fusible element or fusible pin.

### Electronic overload controller (Torque limiter) For sizes 15-34

This device measures the speed of the coupling, stopping the motor or giving a signal when the preselected limit is exceeded. With this device nothing has to be replaced, and after having eliminated the cause of the overload, the transmission can run normally.

# Mesur-Fil Fluid Couplings

## Slip Curves

### Size 7.0

Maximum speed 3,600 RPM (All configurations)

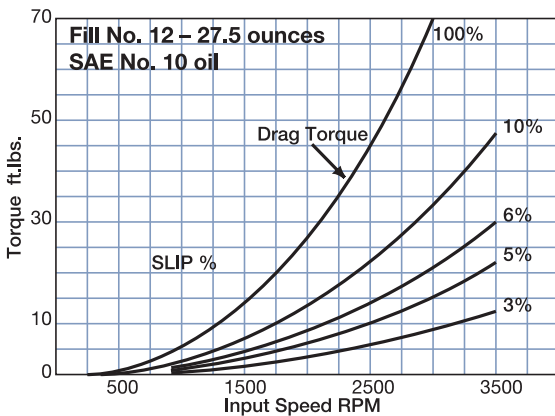
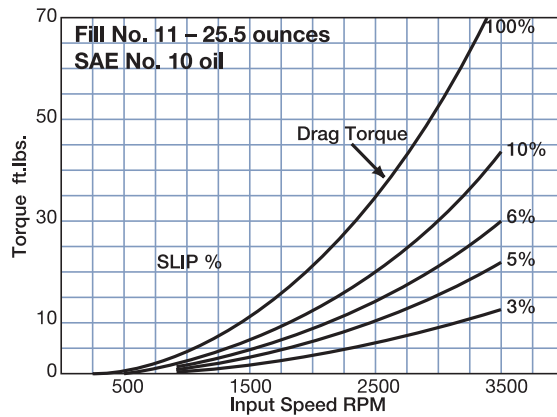
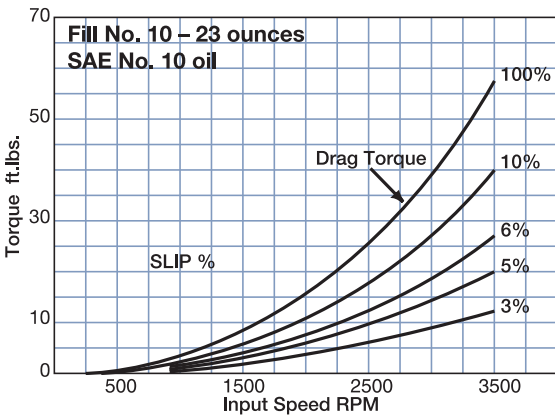
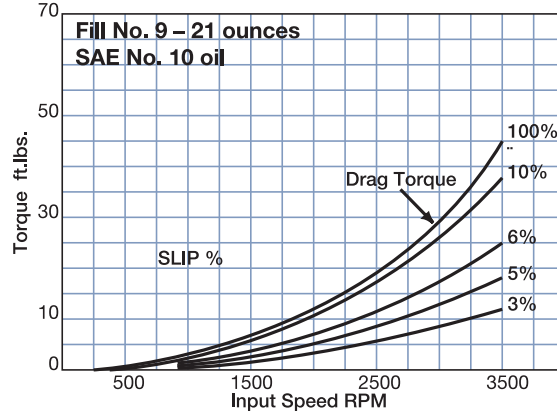
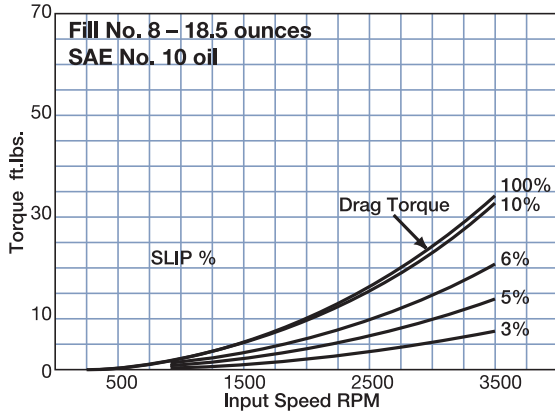

# Mesur-Fil Fluid Couplings

## Slip Curves

### Size 9.4

Maximum speed 3,600 RPM Except HSD-Max. 2,600 RPM

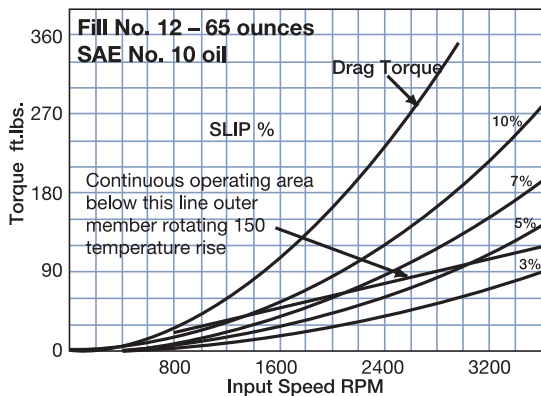
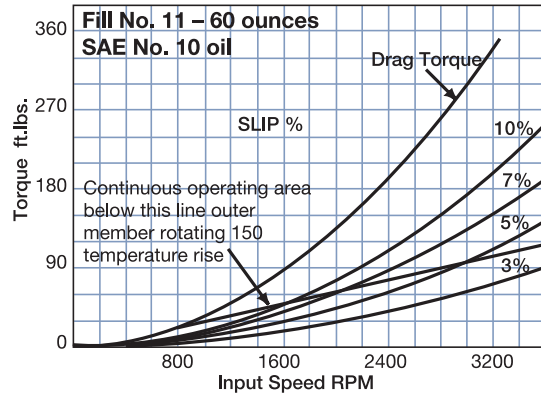
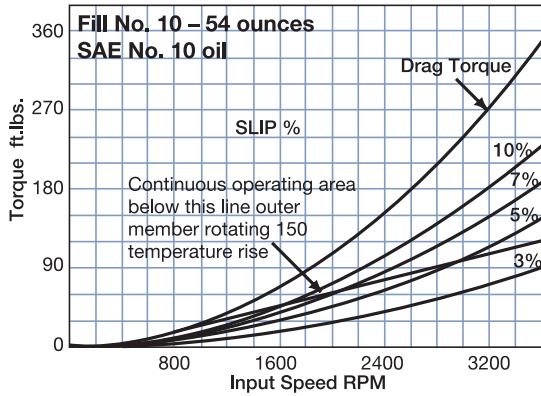
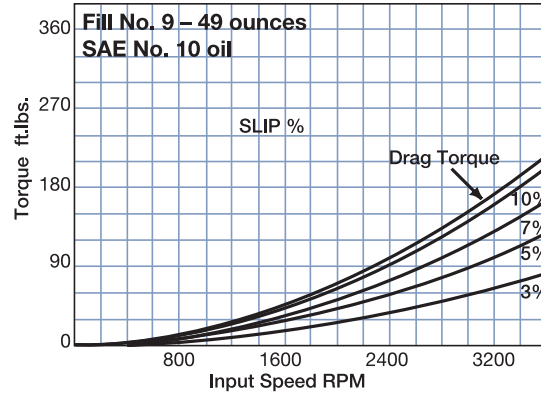
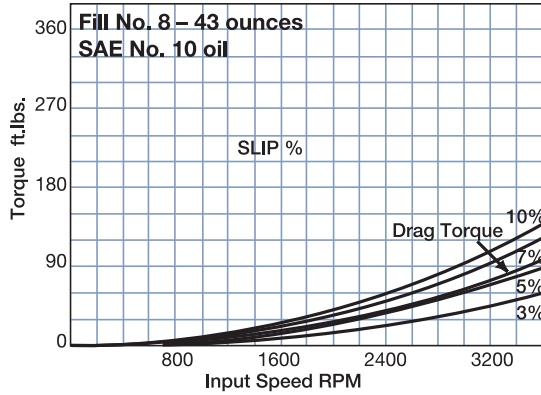

C

# Mesur-Fil Fluid Couplings

## Slip Curves

### Size 12.4

Maximum speed 2,400 RPM Except HSD-Max. 1,800 RPM

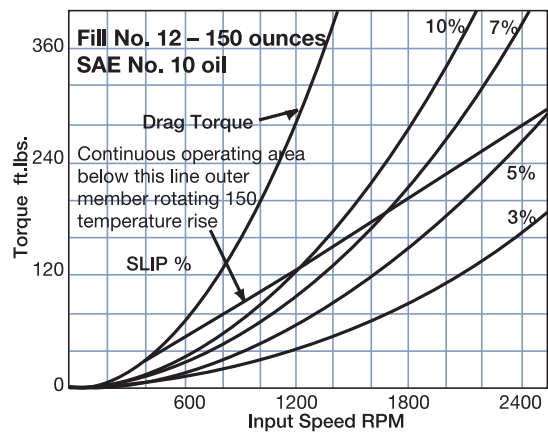
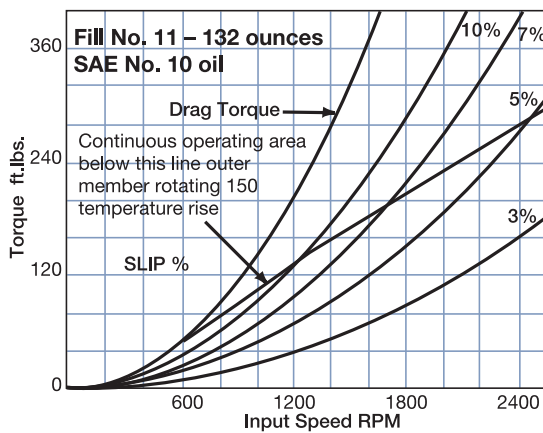
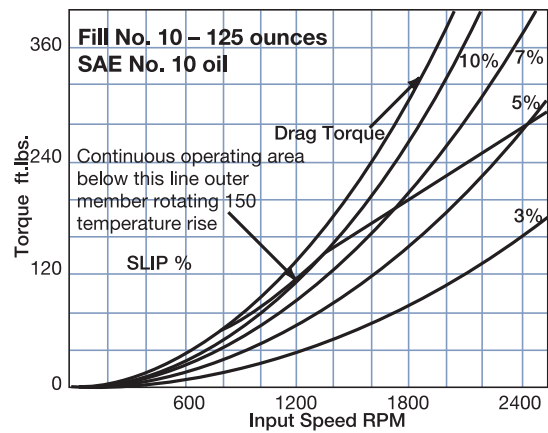
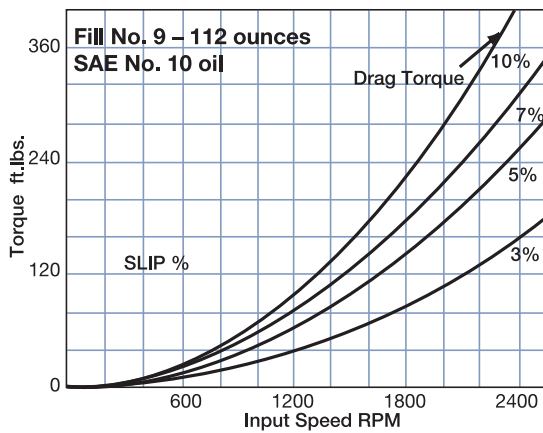
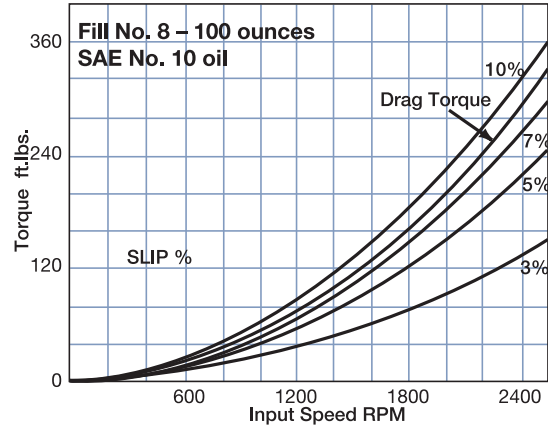
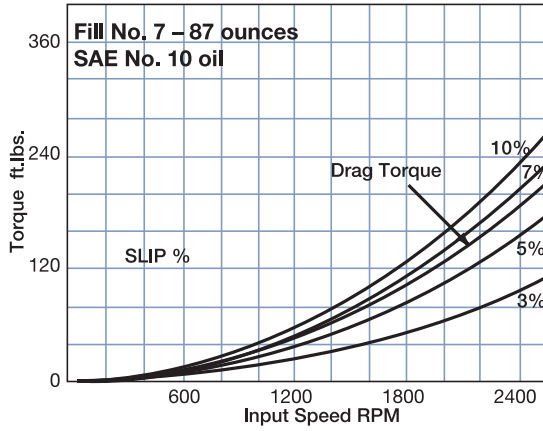

# Mesur-Fil Fluid Couplings

## Slip Curves

Size 15

Maximum speed 2,600 RPM (All configurations)

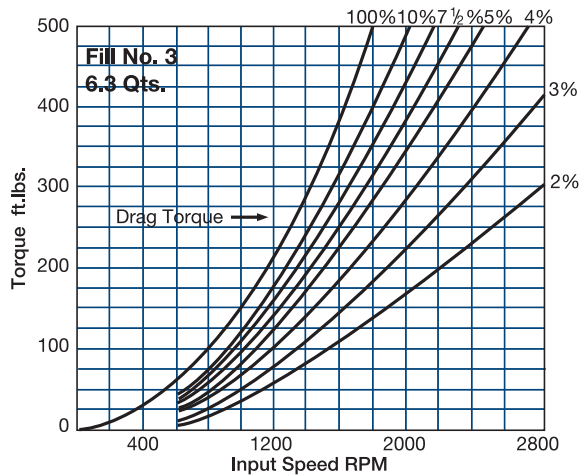
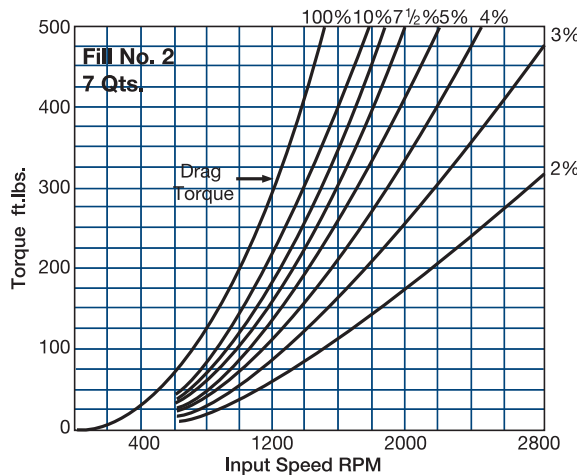
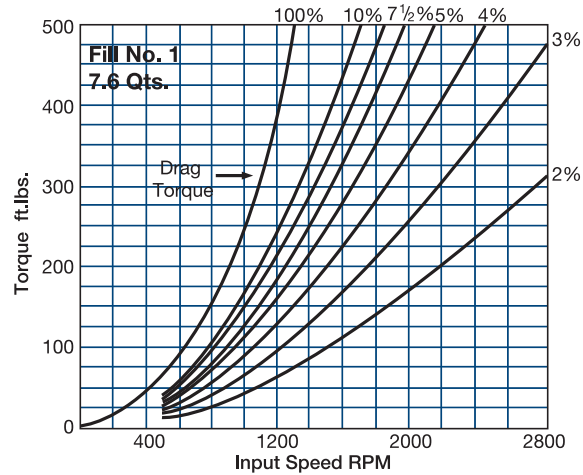
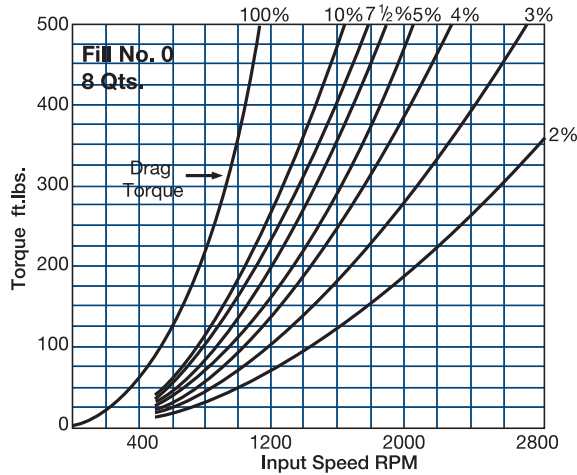

### Selection Example:

7.5 HP at 1,750 RPM

Normal running torque =

$$\frac{7.5 \text{ HP} \times 5,250}{1,750} = 22.5 \text{ lb.ft.}$$

Pullout torque is obtained at approximately 85% full motor speed and for NEMA B motors, this is approximately 200% normal rated torque.

If the pullout torque is unknown, then assume 200% of normal rating occurring at a speed of 1,540 RPM, with full motor speed of 1,750 RPM.

Pullout torque = 2 \* 22.5 lb.ft. = 45 lb.ft.

Locate the pullout torque against RPM curve to insure the point is slightly above the drag torque line.

Locate the normal torque against RPM curve to insure the point is below the 7% slip line. Ideally, plot the point between 3% and 5% slip line.

C

# Mesur-Fil Fluid Couplings

## Modular Design Concept

Sizes 7.0, 9.4, 12.4

### Configuration

#### HCF

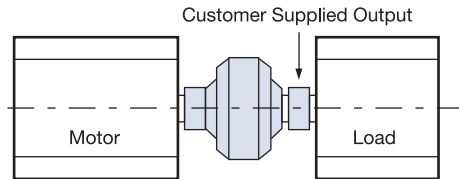

Consists of Model HC and input group. The input group is finish bored to fit standard NEMA B motor shafts. The optional output groups available (HCM, HBM) are shown on this page or the HCF output group must be supplied by the customer. Consult engineering for details.

#### HCM

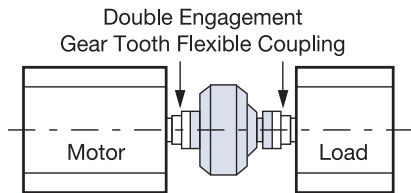

The Model HCM Fluid Coupling is a complete unit with both input and output flanges. It is intended for installation between two halves of a double engagement gear tooth flexible coupling which is customer supplied.

#### HBM

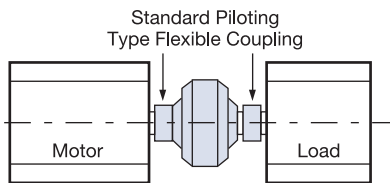

This coupling is a complete unit with a straight input and output shaft. It is installed between two piloting type flexible couplings supplied by the customer.

#### HSD

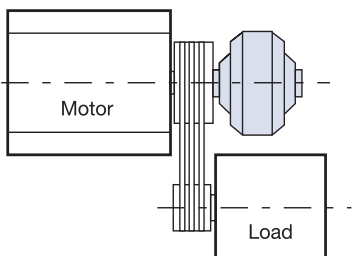

The Model HSD Fluid Coupling consists of a basic fluid coupling, input and output group, and a standard customer supplied QD type sheave. Hydro-sheave couplings provide minimal overhung loads for parallel (belt-driven) applications. The sheave is mounted on a coupling installed on the end of a driveshaft.

Mesur-Fil Couplings can be installed very quickly and easily utilizing a slotted collet for mounting on the motor shaft instead of the center bolt that is most commonly used with other sheave drives. Unlike the center bolt, the slotted collet requires no drilling and tapping of the end of the motor shaft. The slotted collet is finished bored to fit standard NEMA B motor shaft dimensions. Available bore sizes are found elsewhere in this brochure.



# Mesur-Fil Fluid Couplings

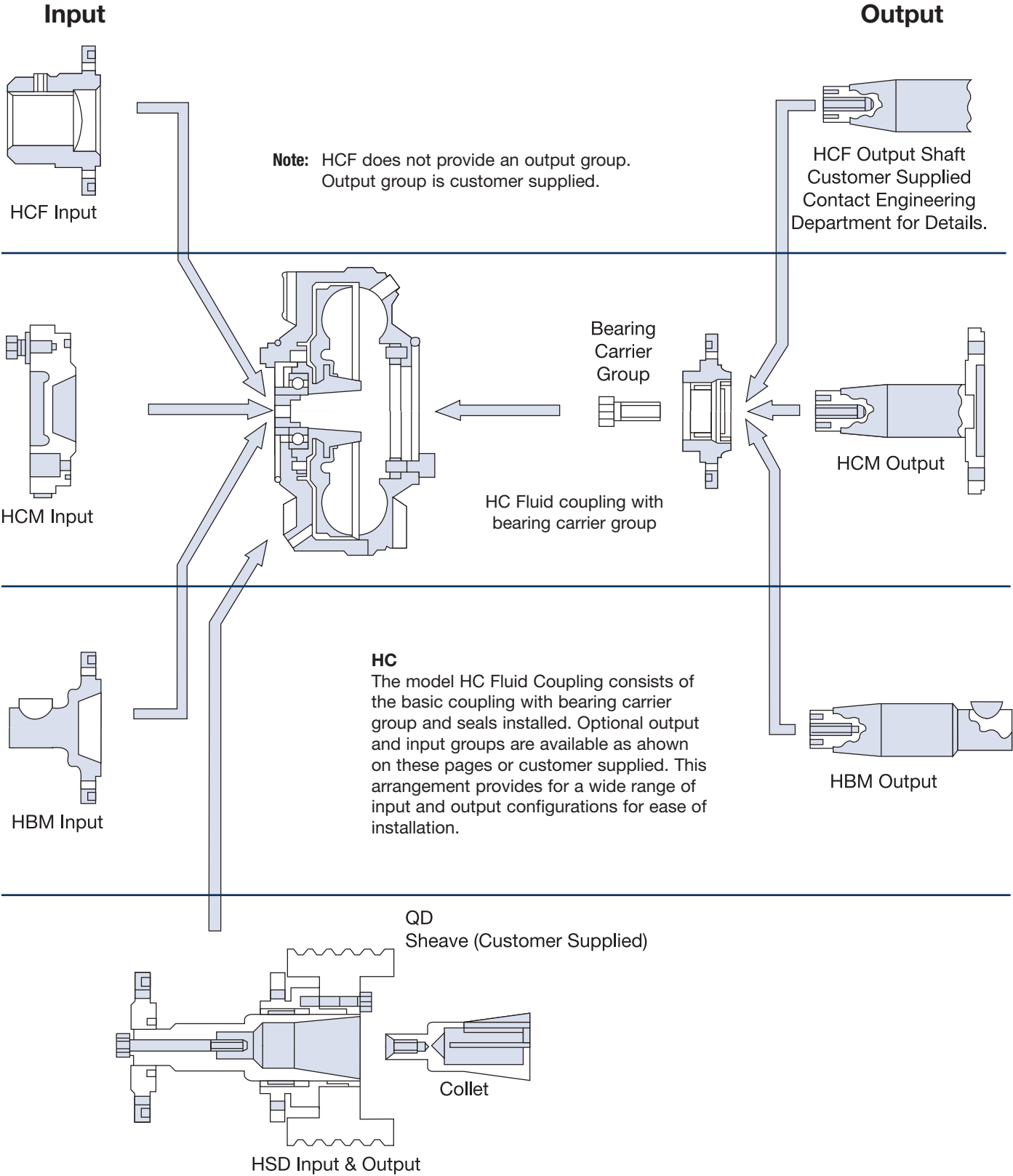

C

# Mesur-Fil Fluid Couplings

## Model HC (Custom Applications)

Sizes 7.0 – 12.4

Size	Assembly Number
7.0	6-607-001-002-0000
9.4	6-609-001-001-0000
12.4	6-612-001-002-0000
3/8" NPT Fusible Plug	4-619-068-000-0

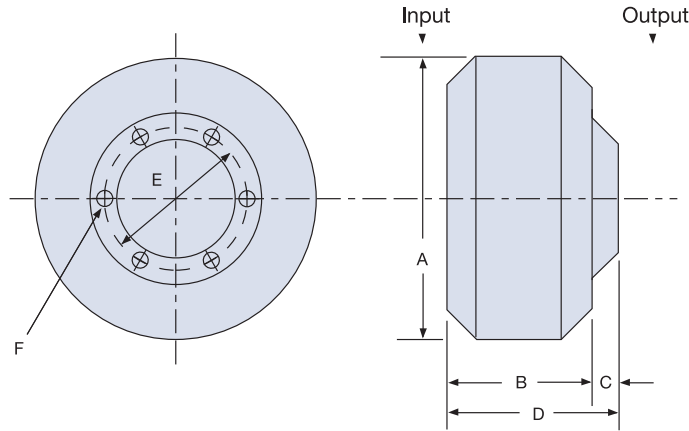

### Dimensions: inches

Size	A	B	C	D	E	F	Wt. Lb. Less Oil	Oil US Oz. Max.
7.0	7.81	3.67	.56	4.23	3.188	17/64	10.1	27.6
9.4	10.25	4.70	.77	5.47	4.250	25/64	20.5	65
12.4	13.50	5.98	.82	6.80	5.650	25/64	38.0	150

### Output Shaft

(Detail drawing)

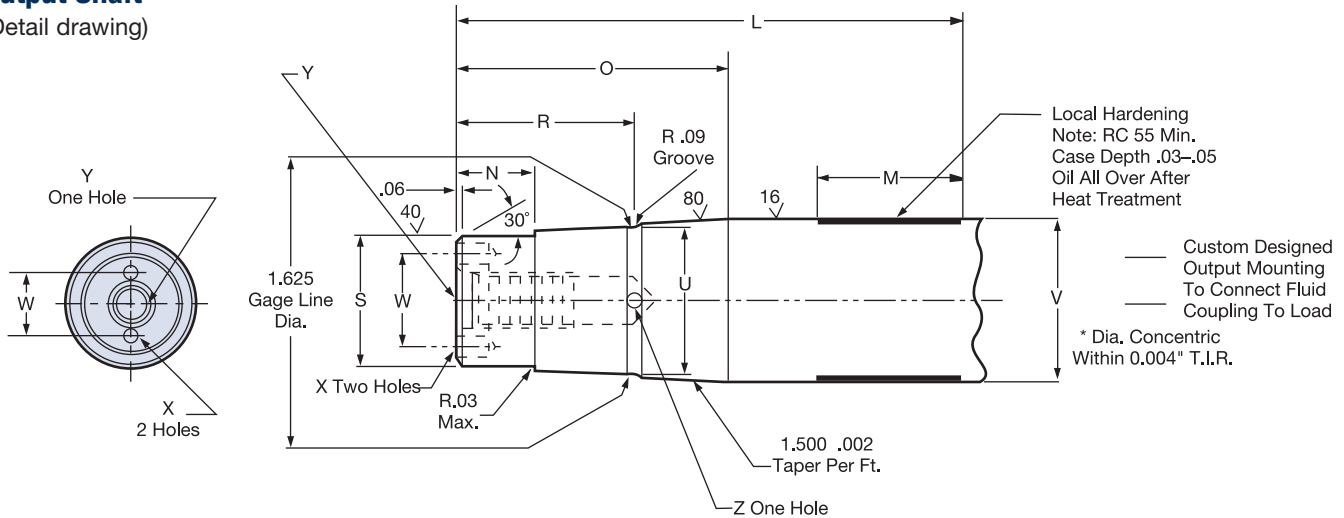

### Dimensions: inches

Size	L	M	N	O	R	S	U	V	W	X	Y	Z
7.0	4.17	1.50	1.270	1.91	.60	.9845	1.124	1.250	.750	9/64	1.10	.60
						.9839	1.116	1.249		x .26		
9.4	5.42	1.50	1.905	2.90	.83	1.3782	1.577	1.850	1.062	13/64	.96	.80
						1.3776	1.589	1.749		x .50		
12.4	6.75	1.80	2.05	3.156	.90	1.5746	1.785	2.000	1.125	13/64	.96	.90
						1.5750	1.777	1.994		x .50		

# Mesur-Fil Fluid Couplings

## Model HBM (Shaft-to-Shaft Applications)

Sizes 7.0 – 12.4

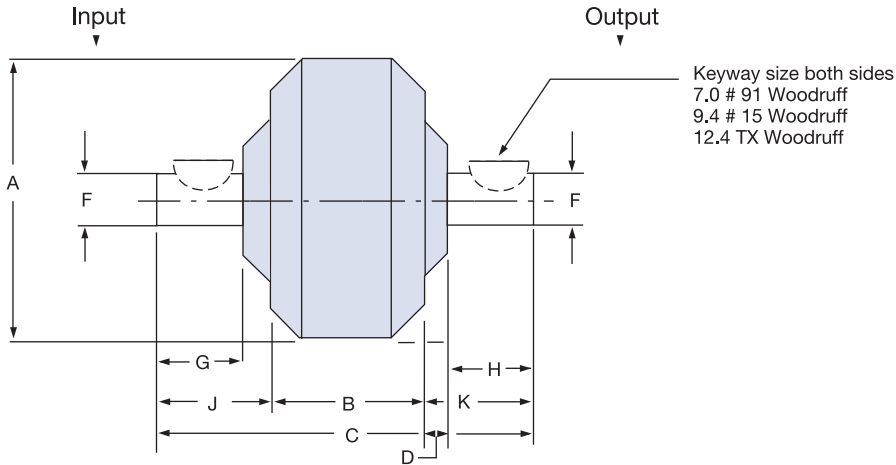

Size	Assembly Number
7.0	6-607-004-000-0000
9.4	6-609-004-000-0000
12.4	6-612-004-000-0000
3/8" NPT Fusible Plug	4-619-068-000-0

### Dimensions: inches

Size	A	B	C	D	F	G	H	J	K	Wt. lb. Less Oil	Max. oz.
7.0	7.81	3.67	8.25	.56 .999	1.000	1.62	1.62	2.34	2.24	12.65	27.6
9.4	10.25	4.70	10.89	.77 1.249	1.250	2.06	2.12	3.10	3.09	27.70	65
12.4	13.50	5.98	13.67	.82 1.624	1.625	2.12	2.75	3.88	3.88	51.07	150

### Single Flexing Coupling

7.0	AJ15*
9.4	AJ30*
12.4	AJ30*

\* Refers to TB Wood's Form-Flex couplings

# Mesur-Fil Fluid Couplings

## Model HCM (Flexible Gear Couplings with Shrouded Bolts)

Sizes 7.0 – 12.4

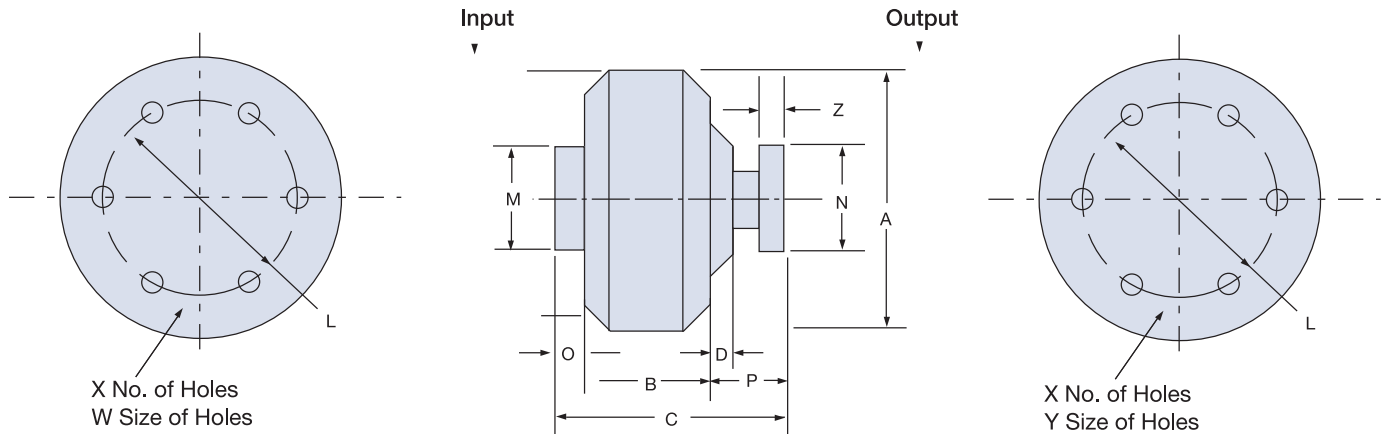

Size	Assembly Number
7.0	6-607-003-000-0000
9.4	6-609-003-000-0000
12.4	6-612-003-000-0000
3/8" NPT Fusible Plug	4-619-068-000-0

### Dimensions: inches

Size	A	B	C	D	L	M	N	O	P	W	X	Y	Z	Wt. lb. Less Oil	Oil Max. oz.	WR <sup>2</sup> lb.ft. <sup>2</sup>		Gear Coupling Size
																Outer	Inner	
7.0	7.81	3.67	5.98	.56	3.75	4.70	4.56	1.10	1.21	1/4-20 .56 Deep	6	.254 .256	3/16	16.10	27.6	.42	.10	1
9.4	10.25	4.70	7.49	.77	4.812	5.90	6.00	1.14	1.65	3/8-16 .65 Deep	8	.380 .382	1/4	32.25	65	1.27	.51	1-1/2
12.4	13.50	5.98	8.67	.82	4.812	6.85	6.00	1.14	1.55	3/8-16 .74 Deep	8	.380 .382	1/4	53.25	150	4.12	1.33	1-1/2

### HCM

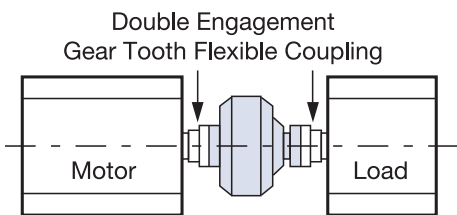

The Model HCM Fluid Coupling is a complete unit with both input and output flanges. It is intended for installation between two halves of a double engagement gear tooth flexible coupling which is customer supplied.

Size	Manufacturer	Model	Maximum Bore	Diameter of Shrouded Bolt Circle
7.0	TB Woods	1F	1.75	3.75
	Waldron	1W	1.63	3.750
	Poole	MXB 1	1.63	3.750
9.4 and 12.4	TB Woods	1.5F	2.25	4.812
	Amerigear	201.5	2.38	4.812
	Waldron	1.5 W	2.19	4.812
	Poole	MXB 1.5	2.19	4.812

**Note:** Gear couplings must be with Shrouded Bolts!

# Mesur-Fil Fluid Couplings

## Model HCM (Flexible Gear Couplings with Shrouded Bolts)

Sizes 15 – 34

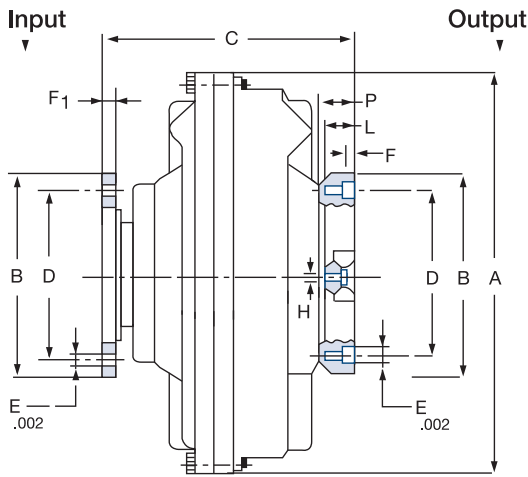

Standard (non-delayed)  
**HCM**

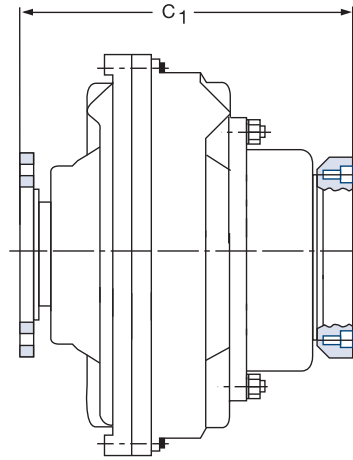

Delayed  
**HCMD**

### Assembly Numbers

Size	Standard (Non-Delay)	Delay Chamber
15	6-615-003-002-0000	6-615-003-004-1000
17	6-617-003-002-0000	6-617-003-002-1000
19	6-619-003-002-0000	6-619-003-002-1000
21	6-621-003-002-0000	6-621-003-002-1000
24	6-624-003-002-0000	6-624-003-002-1000
27	6-627-003-001-0000	6-627-003-001-1000
29	6-629-003-001-0000	6-629-003-001-1000
34	6-634-003-001-0000	6-634-003-001-1000

Size	E			Nr.	Dia.	F	F <sub>1</sub>	H	L	C	C <sub>1</sub>	Wt. lb. Less Oil	Oil U.S. gal. Max.	WR <sup>2</sup> lb.ft. <sup>2</sup>		Outer for HCMD	Gear Coupling
	A	B	D											Outer	Inner		
15	18.11	8.385	7.000	10	0.502	0.354	0.394	1/2-20	0.945	9.84	12.95	▲ 104 ▲ 112	2.02 ▲ 2.27	13.5	4.5	▲ 14.6	2-1/2
17	20.47	8.385	7.000	10	0.502	0.374	0.394	1/2-20	1.000	9.84	13.079	▲ 146 ▲ 158	3.09 ▲ 3.48	22.5	8.6	▲ 25.0	2-1/2
19	22.24	8.385	7.000	10	0.502	0.374	0.394	1/2-20	1.000	9.84	13.079	▲ 165 ▲ 178	3.75 ▲ 4.22	33	14.5	▲ 35.1	2-1/2
21	24.41	8.385	7.000	10	0.502	0.374	0.394	1/2-20	1.22	12.59	16.38	▲ 240 ▲ 262	5.02 ▲ 6.07	51	23	▲ 57.2	2-1/2
24	27.95	8.385	7.000	10	0.502	0.374	0.394	1/2-20	1.22	12.59	16.38	▲ 285 ▲ 307	7.50 ▲ 8.24	96	46	▲ 102.2	2-1/2
27	30.71	11.020	9.500	8	0.750	0.866	1.220	3/4-10	2.008	16.06	20.71	▲ 454 ▲ 505	11.09 ▲ 13.21	145	48	▲ 160.0	3 1/2*
29	33.86	11.020	9.500	8	0.750	0.866	1.220	3/4-10	2.008	17.20	21.85	▲ 562 ▲ 613	14.53 ▲ 16.64	220.5	66.4	▲ 235.4	3 1/2*
34	39.37	12.159	11.00	8	0.750	0.866	1.102	3/4-10	2.283	24.96	28.90	▲ 960 ▲ 978	21.80 ▲ 24.5	650	28.5	▲ 668.5	4*

▲ HCMD \*Exposed Bolts

# Mesur-Fil Fluid Couplings

## Model HSD (Parallel Shaft Applications)

Sizes 7.0 – 12.4

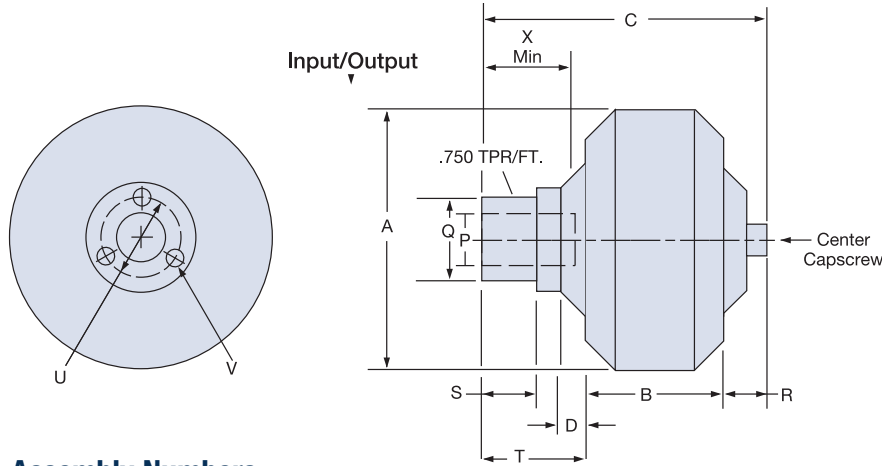

### P = Standard Input Sizes

Size	Bore	Key
7.0	7/8	3/16
	1	1/4
	1 1/8	1/4
	1 3/8	5/16

Size	Bore	Key
9.4	1 1/8	1/4
	1 3/8	5/16
	1 5/8	3/8

Size	Bore	Key
12.4	1 5/8	3/8
	1 7/8	1/2
	2 1/8	1/2
	2 3/8	5/8

### Assembly Numbers

Size	Bore (in.)	Assembly Number
7.0	7/8	6-607-005-001-0000
	1	6-607-005-002-0000
	1-1/8	6-607-005-003-0000
	1-3/8	6-607-005-004-0000
9.4	1-1/8	6-609-005-001-0000
	1-3/8	6-609-005-002-0000
	1-5/8	6-609-005-003-0000
12.4	1-5/8	6-612-005-001-0000
	1-7/8	6-612-005-002-0000
	2-1/8	6-612-005-003-0000
	2-3/8	6-612-005-004-0000
3/8" NPT Fusible Plug		4-619-068-000-0

### Dimensions: inches

Size	A	B	C	D	Q	R	S	T	U	V	X	Q.D. Hub Size	Dry Wt.
7	7.81	3.67	7.05	.56	2.149	.84	1.15	2.54	2.687	1/2-20	2.00	SD	12.75
9.4	10.25	4.70	9.35	.77	2.736	1.12	1.45	3.53	3.313	5/16-18	2.50	SK	37.75
12.4	13.50	5.98	12.12	.82	3.736	1.24	1.87	4.90	5.000	1/2-13	3.00	E	68.00

Do not use Eaton QD sheaves.  
Bolt pattern is not the same.

### Vertical Mounting For HSD

When mounting the 7.0, 9.4 or 12.4 HSD on a vertical shaft, the motor and collet should be mounted above the sheave and fluid coupling. This position insures even the smallest oil fill will react with the motor.

Furthermore, order the unit with the standard and optional fill plugs on both sides of the unit. This allows for the addition and maintenance of the oil level within the fluid coupling.

HSD	Maximum Speed
7.0	3,600 RPM
9.4	2,600 RPM
12.4	1,800 RPM

Model Size	Casting on Housing
7.0	216262 A
	216405 A
9.4	216438 A
	216439 A
12.4	219463 A
	219464 A

### Important note:

Size	Center Capscrew Torque
7.0	38-42 lb.ft.
9.4 and 12.4	177-195 lb.ft.

# Mesur-Fil Fluid Couplings

## Model HSD

### Sizes 15-24

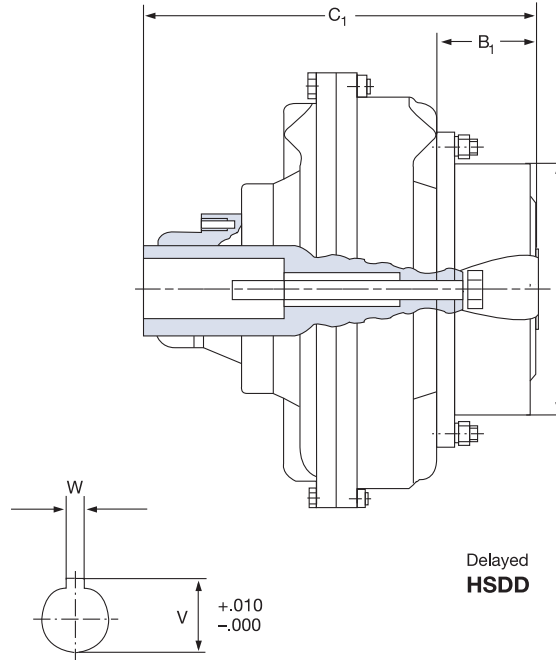
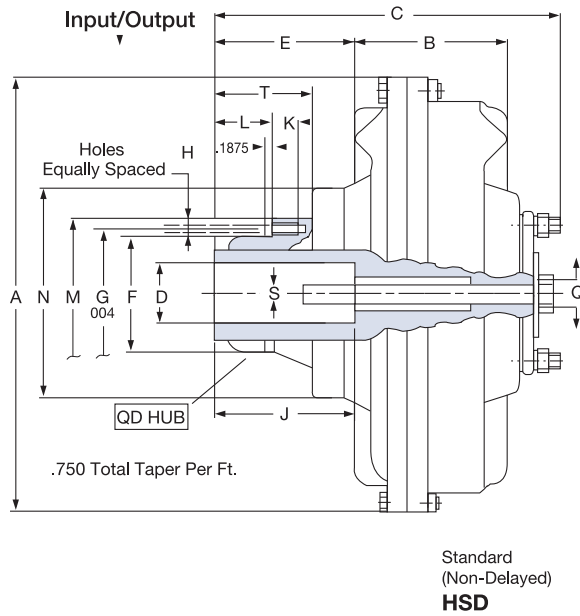

### Assembly Numbers

Size	Bore (in.)	Standard (Non-Delay)	Delay Chamber
15	2-7/8	6-615-005-001-0000	6-615-005-001-1000
	2-3/8	6-615-005-002-0000	6-615-005-002-1000
17	2-7/8	6-617-005-001-0000	6-617-005-001-1000
	3-3/8	6-617-005-002-0000	6-617-005-002-1000
19	3-3/8	6-619-005-001-0000	6-619-005-001-1000
	2-7/8	6-619-005-002-0000	6-619-005-002-1000
21	3-7/8	6-621-005-001-0000	6-621-005-001-1000
	3-3/8	6-621-005-002-0000	6-621-005-002-1000
24	3-3/8	6-624-005-001-0000	6-624-005-001-1000
	3-7/8	6-624-005-002-0000	6-624-005-002-1000

### Tolerance:

Dim D	up to 2 inch	+0.01
		-.000
Dim W	from 2 to 4 inch	+0.015
		-.000
Dim W	up to .500 inch	+0.002
		-.000
Dim W	from .625 to 1 inch	+0.003
		-.000

### Dimensions: inches

Size	D	J	W	V	A	B	B <sub>1</sub>	C Max.	C <sub>1</sub>	E	F	G	H Nr. Dia.	I	K	L	M	N	Q	T	S	QD Hub Size	Wt. Less Oil	Oil US Gal Max.
15	2.875	7.000	.750	2.992	18.110	5.945	3.425	15.118	17.244	7.677	4.4375	5.625	3	10.039	1.181	3.397	6.663	8.032	7/8 9 UNC	6.362	3/4 10 UNC	F	107	2.02
15	2.375	5.625	.625	2.651	18.110	5.945	3.425	15.118	17.244	7.677	4.4375	5.625	3	10.039	1.181	3.397	6.663	8.032	7/8 9 UNC	6.362	3/4 10 UNC	▲	115.8	▲ 2.27
17	3.375	8.250	.875	3.635	20.472	6.693	3.779	17.913	20.315	9.654	5.1484	6.250	3	12.992	1.378	4.331	7.25	8.976	7/8 9 UNC	8.449	7/8 9 UNC	J	156	3.09
17	2.875	7.000	.750	3.205	20.472	6.693	3.779	17.913	20.315	9.654	5.1484	6.250	3	12.992	1.378	4.331	7.25	8.976	7/8 9 UNC	8.449	7/8 9 UNC	▲	169.2	▲ 3.48
19	3.375	8.250	.875	3.635	22.244	7.480	3.779	17.913	20.315	8.858	5.1484	6.250	3	12.992	1.378	4.331	7.25	8.976	1-1/4 7 UNC	8.449	7/8 9 UNC	J	174	3.75
19	2.875	7.000	.750	3.205	22.244	7.480	3.779	17.913	20.315	8.858	5.1484	6.250	3	12.992	1.378	4.331	7.25	8.976	1-1/4 7 UNC	8.449	7/8 9 UNC	▲	187.2	▲ 4.22
21	3.875	8.500	1.000	4.314	24.409	8.071	4.330	21.456	24.408	11.811	6.500	7.875	4	15.748	1.575	7.085	9.00	9.842	7/8 9 UNC	10.236	3/4 10 UNC	M	270	5.02
21	3.375	8.250	.875	3.760	24.409	8.071	4.330	19.882	22.833	10.236	6.500	7.875	4	15.748	1.575	5.511	9.00	9.842	7/8 9 UNC	8.661	3/4 10 UNC	▲	292	▲ 6.08
24	3.875	8.500	1.000	4.314	27.953	9.015	4.528	21.456	24.408	10.866	6.500	7.875	4	15.748	1.575	7.085	9.00	10.394	7/8 9 UNC	11.024	3/4 10 UNC	M	307	7.50
24	3.375	8.250	.875	3.760	27.953	9.015	4.528	19.882	22.835	9.291	6.500	7.875	4	15.748	1.575	5.512	9.00	10.394	7/8 9 UNC	9.449	3/4 10 UNC	M	▲ 329	▲ 8.24

### ▲ HSDD

● Max. Bore

■ With Reduced Depth Keyway

# Engineering Data

## How to Calculate Inertia (WR<sup>2</sup>) of a Spoked Wheel

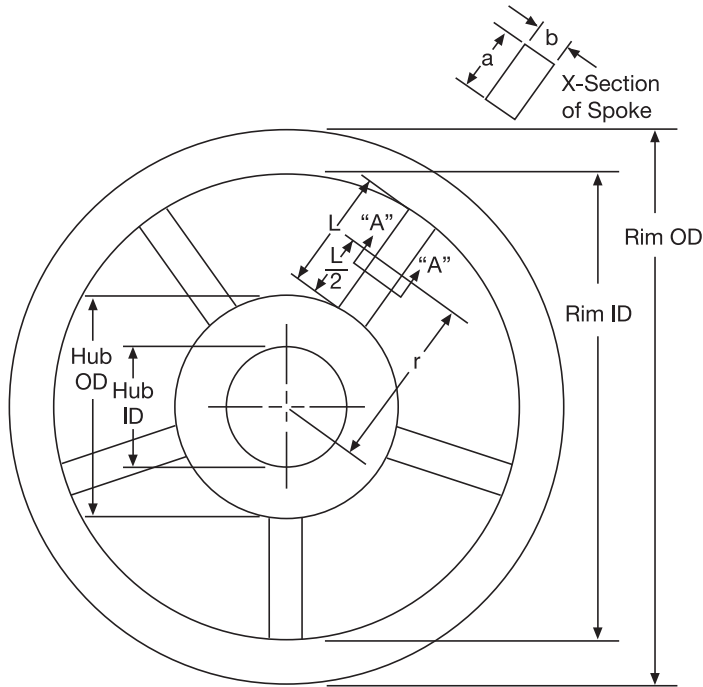

$$WR^2_S \text{ of Spokes} = \left[ \left( \frac{b^2 + L^3}{1728} \right) + \left( \frac{r^2}{144} \right) \right] \times (\text{wt of Spokes}) \times (\text{No. of Spokes}), \text{ lb.ft.}^2$$

$$WR^2 \text{ of Rim} = \left[ \frac{(\text{Rim OD})^2 + (\text{Rim ID})^2}{1152} \right] \times (\text{wt of Rim}), \text{ lb.ft.}^2$$

$$WR^2 \text{ of Hub} = \left[ \frac{(\text{Hub OD})^2 + (\text{Hub ID})^2}{1152} \right] \times (\text{wt of Hub}), \text{ lb.ft.}^2$$

$$\text{Total Flywheel Inertia} = WR^2_S + WR^2_R + WR^2_H$$

**Note:** All dimensions are in inches.

### Clutch heat horsepower absorption rate

Absorption rate/in.<sup>2</sup> of lining area. For one stop at 70°F ambient temperature.

Slip time seconds		0 to 1	2	3	4	5	6	7	8	9	10
Heat Input	$\frac{\text{lb.ft.}}{\text{in.}^2}$	380	617	820	1000	1175	1330	1485	1630	1770	1900
	$\frac{\text{HP}}{\text{in.}^2}$	.7	.56	.5	.45	.43	.4	.38	.37	.36	.34
	$\frac{\text{btu}}{\text{in.}^2}$	.49	.79	1.05	1.29	1.51	1.71	1.91	2.09	2.27	2.4

Consult factory for slip time over 10 seconds.





### Definitions

T	Torque-The moment of a system tends to cause rotation lb.in. % forces.
WR <sup>2</sup>	Inertia-weight times radius of gyration <sup>2</sup> lb.ft. <sup>2</sup>
PSI	Pounds per square inch.
Wt.	Weight-lbs.
Btu	British Thermal Unit = 778 lb.ft. or one Btu.
CPM	Cycles per minute.
CF	Coefficient of friction.
C°	Degrees Celcius.
F°	Degrees Fahrenheit.
LN	Natural base log.
K and U	Inflation coefficients for specific clutch and brake. See specification tables.
R, E and V	Exhaust coefficient for specific clutch and brake. See specification tables.
KW	Keyway.
RPM	Revolutions per minute.
t	Seconds.
TIR	Total Indicator run out.
V	Volume-in <sup>3</sup> .
HP	Given amount of work in a specific time. 1 horsepower = 33,000 lb.ft. per minute.

### Formulas

Torque lb. in. = $\frac{(HP) (63,000)}{RPM}$
Horsepower HP = $\frac{(\text{Torque lb.in.}) (RPM)}{(63,000)}$
Acceleration Torque (lb.in.) = $\frac{(WR^2) (RPM)}{(25.6)(t)}$ t= time in seconds for acceleration or deceleration.
HP/100 RPM = $\frac{(HP) (100)}{(RPM)} = \frac{\text{Required Torque lb.in.}}{(630)}$
Required Unit PSI = $\frac{(\text{Unit required Torque lb.in.}) (100 \text{ PSI})}{(\text{Unit rated torque lb.in.})}$
Contact velocity FPM = $\frac{(\text{Unit diameter in.}) (\pi)(RPM)}{(12)}$
Unit heat HP = $\frac{(\text{Total } WR^2) (RPM)^2 (CPM)}{1.9 \times 10^6}$

# Engineering Data

## Tension Value Charts

Material	Tension (lb.in. of web width)
Steel foils	1.5 to 4
Aluminum foils	0.5 to 1.5 (1.0 aver.)/mil
Cellophanes	0.5 to 1.0/mil
Acetate	0.5/mil
Mylar (Polyester)	0.25 to 0.30/mil
Polyethylene	0.25 to 0.30/mil
Polypropylene	0.25 to 0.30/mil
Polystyrene	1.0/mil
Saran	0.05 to 0.20 (0.10 aver.)/mil
Vinyl	0.05 to 0.20 (0.10 aver.)/mil
<b>Paper and Laminations</b>	
20#/R—32.54 gm/m <sup>2</sup>	0.50 to 1.0
40#/R—65.08 gm/m <sup>2</sup>	1.0 to 2.0
60#/R—97.62 gm/m <sup>2</sup>	1.5 to 3.0
80#/R—130.0 gm/m <sup>2</sup>	2.0 to 4.0
<b>Paper</b>	
15 lbs./ream (3000 sq.ft.)	0.5
20 lbs./ream	0.75
30 lbs./ream	1.0
40 lbs./ream	1.5
80 lbs./ream	2.5
<b>Laminations</b>	
25 LB. PAPER/.005	
PE/.00035" FOIL/.001"PE	3.0
.001" Cello/.0005"PE/.001"	
Cello	1.5
When these substrates are coated with polyethylene, nylon polypropylene EVA, EAA, and EEA, add the following tension to the values listed above for the substrate only.	
<b>Coating Thickness</b>	
0.0005" to 0.0001	0.12
0.0011" to 0.002	0.25
<b>Cellophane</b>	
.00075"	0.5
.001"	0.75
.002"	1.0

Material	Tension (lb.in. of web width)
<b>Nylon and Cast Propylene (non-Oriented)</b>	
.00075"	0.15
.001"	0.25
.002"	0.5
<b>Mylar and Oriented Propylene</b>	
0.0005"	0.25
0.001"	0.5
0.002"	1.0
<b>Paperboard</b>	
8 pt.	3.0
12 pt.	4.0
15 pt.	5.0
20 pt.	7.0
25 pt.	9.0
30 pt.	11.0
Material	Tension (lb./strand)
<b>Aluminum Wire</b>	
#20 AWG	4.00
#18 AWG	5.50
#16 AWG	9.00
#14 AWG	10.00
#12 AWG	12.00
#10 AWG	15.00
#8 AWG	25.00
<b>Copper Wire</b>	
#20 AWG	8.00
#18 AWG	10.00
#16 AWG	12.00
#14 AWG	15.00
#12 AWG	18.00
#10 AWG	20.00
#8 AWG	25.00

<b>ATHP</b>	<b>Air-tube Holding Plate:</b> A Plate having a cavity which houses the air-tube.	<b>DAF</b>	<b>Driving Adapter Flange:</b> A driving ring connecting the driving adapter and the clutch's driving ring.
<b>AT</b>	<b>Air-tube:</b> Actuating member, full circle polyester reinforced neoprene tube.	<b>DI</b>	<b>Ductile Iron:</b> Nodular cast iron, a semi-steel.
<b>AT/P</b>	<b>Air-tube Pancake Style:</b> Air-tube which does not have center hole as in regular air-tube.	<b>DSCP</b>	<b>Ductile Slotted Center Plate:</b> A ductile, cast iron center plate that has thermal growth slots in the plate to allow for thermal growth of center plate.
<b>AT/S</b>	<b>Air-tube Split:</b> A regular air-tube that is split radially for temporary replacement of a regular air-tube. This has a comparatively short life expectancy.	<b>DCP</b>	<b>Ductile Center Plate:</b> Center plate made of ductile iron (Nodular cast iron).
<b>ALD</b>	<b>Axial Locking Device:</b> This device axially locks two shafts together without transmitting torque. Its primary use is in attaching a sleeve bearing motor to an axially located pinion shaft.	<b>DR</b>	<b>Driving Ring:</b> Unit's outer housing. Transmits torque from friction discs.
<b>BP</b>	<b>Back Plate:</b> The retaining plate on the opposite end of the clutch or brake unit. It is either bolted to the low inertia driving ring or the standard-special ventilated clutch hub.	<b>DMBP</b>	<b>Demountable Backplate:</b> A removable backplate which allows access from rear of unit.
<b>CCB</b>	<b>Combination Clutch Brake</b>	<b>E to P</b>	<b>Current to Pneumatic Transducer</b>
<b>CI</b>	<b>Cast Iron:</b> Iron material with sufficient carbon so it is not malleable at any temperature.	<b>FD</b>	<b>Friction Disc:</b> Molded friction elements.
<b>C/P</b>	<b>Center Plate:</b> This plate is of metal and has a gear tooth spline or other driving system on the internal diameter of the plate that meshes with the clutch or brake hub.	<b>F/P</b>	<b>Floating Plate:</b> Similar to Center Plate, next to the pressure plate.
<b>CWJ</b>	<b>Center Water Jacket:</b> This is a two wear sided water jacket assembly that is splined on the outside diameter. This part is used in a water cooled clutch or brake of more than one drive plate.	<b>FWJ</b>	<b>Floating Water Jacket:</b> Similar to Center Water Jacket. Located between pressure plate and drive plate assembly.
<b>CWP</b>	<b>Copper Wear Plate:</b> Copper disc mounted to a water jacket.	<b>FP</b>	<b>Friction Puck:</b> Segmented friction element used on drive plate assemblies.
<b>DA</b>	<b>Driving Adapter:</b> A device to bolt a standard ventilated type clutch driving ring to a shaft.	<b>G1S</b>	<b>Friction Disc:</b> Grooved one side.
		<b>G1SSH</b>	<b>Friction Disc:</b> Grooved one side with spring holes.
		<b>G2SBB</b>	<b>Friction Disc:</b> Grooved two sides back to back.
		<b>G2SBBSH</b>	<b>Friction Disc:</b> Grooved two sides back to back with spring holes.
		<b>G2SSSH</b>	<b>Friction Disc:</b> Grooved two sides staggered with spring holes.

# Glossary Of Terms

---

<b>GID</b>	<b>Friction Disc:</b> Grooved on inside diameter.	<b>OSO</b>	<b>Obsolete Service Only:</b> Discontinued service.
<b>GPM</b>	<b>Gallons Per Minute</b>	<b>PLI</b>	<b>Pounds Per Linear Inch</b>
<b>HUB &amp; ATHP</b>	<b>Hub and Air-tube Holding Plate:</b> Special one piece design.	<b>PLK</b>	<b>Positive Lock:</b> Special unit allowing direct drive between air-tube holding plate and the ring in case of air-tube failure.
<b>HC</b>	<b>High Coefficient Friction</b>	<b>QRV</b>	<b>Quick Release Valve:</b> Springless exhausting air valve.
<b>HS</b>	<b>High Speed:</b> Special air-tube designed for high speed applications.	<b>QCRG</b>	<b>Quick Change Ring:</b> A driving ring connecting the driving adapter and the clutch's driving ring used for quick access to clutch's internal parts.
<b>HT</b>	<b>High Torque:</b> Clutch design with pancake air-tube.	<b>RCS</b>	<b>Roto Coupling Spider:</b> A clutch air manifold, with its center tapped to accept a roto coupling.
<b>HUB &amp; BP</b>	<b>Hub and Backplate:</b> Special one-piece design.	<b>RC</b>	<b>Roto Coupling:</b> An air rotary union having a hollow shaft in bearings located within a stationary housing to allow for a supply hose connection without twisting the air hose.
<b>HUB</b>	<b>Hub:</b> Splined tooth gear, keyed to the shaft.	<b>TSCP</b>	<b>Thin Slotted Center Plate:</b> This center plate is similar to the DSCP but is of the thin, usually nonventilated center plate design.
<b>LC</b>	<b>Low Coefficient Friction</b>		
<b>L/T</b>	<b>Low Temperature:</b> Special air-tube designed for low temperatures down to -40° F.		
<b>LPM</b>	<b>Liters Per Minute</b>		
<b>MR</b>	<b>Marine Reverse:</b> Special Standard Vent Clutch.		
<b>NC</b>	<b>National Course:</b> Thread type.		
<b>NF</b>	<b>National Fine:</b> Thread type.		
<b>NPT</b>	<b>National Pipe Thread:</b> Thread type.		
<b>OBS</b>	<b>Obsolete:</b> Discontinued part.		

# Parts List and Assembly Drawing Numbers

## Clutches and Brakes

( ) - ( ) ( ) ( ) - ( ) ( ) ( ) - ( ) ( ) ( ) - ( )

### Group Number

6	Clutch
7	Brake

### TYPE OF UNIT

#### Clutches

When Unit Number is (6)  
Use These Numbers

0	Low Inertia
1	Standard Ventilated
2	Special & Super Vent.
3	Kopper Kool
4	Water Cooled
5	Mechanical
6	Tooth Clutch
7	Power Take Off
8	E.P.
9	Other Than Above

#### Brakes

When Unit Number is (7)  
Use These Numbers

0	Low Inertia
1	Spring Set
2	Motor Brake
3	Kopper Kool
4	Water Cooled
5	Spot or Caliper
6	Band Brake
7	Tandem Mount
8	E.P.
9	Other Than Above And Combo Clutch/Brake

### Size of Unit

01	Less Than 2"
02	
03	
04	4"
05	5"
06	6"
07	7"
08	8"
09	9"
10	10"
11	11"
*	*
*	*
*	*
00	Cannot Be Classified In Two Digits

Note: "H" Clutches are indicated by next inch size up from actual size, i.e., 31 = 30H Unit.

15	14H
19	18H
25	24H
31	30H
37	36H

### Sequential Numbers

#### Numbers of Plates

1	1 Plate
2	2 Plate
3	3 Plate
4	4 Plate
5	5 Plate
6	6 Plate
7	7 Plate
8	8 Plate
9	9 Plate
0	Other Than Above

#### Type of Air Tube

0	No Air Tube
1	Regular
3	High Speed
4	Pancake
5	Low Temperature
8	Diaphragm
9	Other Than Above Or Any Of Above When an Assembly Drawing No.

### Origin

0	U.S.A.
1	English
2	Metric
3	Mixed
4	Drum Type
5	
6	
7	
8	Deleter
9	Indicates An Assembly Drawing No.

### Sequential Numbers

00-99

Use this chart only to interpret a part number issued by Wichita Clutch. Do not use it to determine your own part number.

# The Advantages of Genuine Wichita Replacement Parts

When you specify genuine replacement parts from Wichita Clutch, you automatically expect more... and get more. Especially better performance, longer life, and the peace of mind that comes with knowing that you are working with the industry's proven leader.

We have years of experience in building value into every Genuine Wichita Replacement Part. Our parts, made with quality materials and leading-edge technology, are long lasting, resulting in lower life cycle costs, they also fit precisely to give you the assurance of trouble-free performance.



## Longer Warranty

We have over 60 years of experience in building value into every Genuine Wichita Replacement Part. Our parts, made with quality materials and leading-edge technology, not only last longer than the competition, resulting in lower life cycle costs, they also fit precisely to give you the assurance of trouble-free performance. That's why we can confidently offer you the very best warranty in the business...

3 years on airtubes and 2 years on all other components.

## Faster Delivery

To help you lessen downtime problems, we've recently established new methods and procedures that will get Genuine Replacement Parts to you quicker than ever before. Over 600 of our parts can now be shipped within 24-hours of your order or are available off-the-shelf from your local distributor.

## Competitive Pricing

The good news is you don't have to pay a premium price for all the product and service advantages of Genuine Wichita Replacement Parts. You'll find our prices to be very competitive with any of the companies offering imitation replacement parts.

## Better Service

The expertise of your local distributor could be the difference between getting your machine up and running fast, or standing idle. Your local Wichita distributor is a power transmission specialist, trained and experienced in how to best maintain and repair equipment. Call 800-964-3262 for a FREE equipment check-up.

Wichita Clutch is a part of the heavy-duty clutch and brake division of Altra Industrial Motion, the global leader in power transmission for heavy-duty industrial pneumatic and hydraulically actuated clutches and brakes.

We make it quick and easy for you to find and get **product brochures, catalogs and service manuals** for any of our products.

Visit [www.warnernet.com/litportal](http://www.warnernet.com/litportal)

Simply chose from one of the dropdown lists to search by Brand, Product Family, or Markets Served. Select the download link to view PDF files of any literature item.

### Application Profiles and Published Article Reprints

Be sure to check out our growing list of Application Profiles for information on specific product application stories and Published Article reprints for more in-depth coverage of major application and product stories.



All Customer Service phone numbers shown in bold

## Electromagnetic Clutches and Brakes

### Warner Electric

*Electromagnetic Clutches and Brakes*

New Hartford, CT - USA  
1-800-825-6544

*For application assistance:*  
1-800-825-9050

St Barthelemy d'Anjou, France  
+33 (0) 2 41 21 24 24

*Precision Electric Coils and Electromagnetic Clutches and Brakes*

Columbia City, IN - USA  
1-260-244-6183

### Matrix International

*Electromagnetic Clutches and Brakes, Pressure Operated Clutches and Brakes*

Brechin, Scotland  
+44 (0) 1356 602000

New Hartford, CT - USA  
1-800-825-6544

### Inertia Dynamics

*Spring Set Brakes; Power On and Wrap Spring Clutch/Brakes*

New Hartford, CT - USA  
1-800-800-6445

## Linear Products

### Warner Linear

*Linear Actuators*

Belvidere, IL - USA  
1-800-825-6544

*For application assistance:*  
1-800-825-9050

St Barthelemy d'Anjou, France  
+33 (0) 2 41 21 24 24

## Couplings

### Ameridrives Couplings

*Mill Spindles, Ameriflex, Ameridisc*

Erie, PA - USA  
1-814-480-5000

*Gear Couplings*

San Marcos, TX - USA  
1-800-458-0887

### Bibby Transmissions

*Disc, Gear, Grid Couplings, Overload Clutches*

Dewsbury, England  
+44 (0) 1924 460801

Boksburg, South Africa  
+27 11 918 4270

### TB Wood's

*Elastomeric Couplings*

Chambersburg, PA - USA  
1-888-829-6637 – Press #5

*For application assistance:*  
1-888-829-6637 – Press #7

*General Purpose Disc Couplings*

San Marcos, TX - USA  
1-888-449-9439

### Ameridrives Power Transmission

*Universal Joints, Drive Shafts, Mill Gear Couplings*

Green Bay, WI - USA  
1-920-593-2444

### Huco Dynatork

*Precision Couplings and Air Motors*

Hertford, England  
+44 (0) 1992 501900  
Charlotte, NC - USA  
1-800-825-6544

## Heavy Duty Clutches and Brakes

### Wichita Clutch

*Pneumatic Clutches and Brakes*

Wichita Falls, TX - USA  
1-800-964-3262

Bedford, England  
+44 (0) 1234 350311

### Twiflex Limited

*Caliper Brakes and Thrusters*

Twickenham, England  
+44 (0) 20 8894 1161

### Industrial Clutch

*Pneumatic and Oil Immersed Clutches and Brakes*

Waukesha, WI - USA  
1-262-547-3357

## Gearing

### Boston Gear

*Enclosed and Open Gearing, Electrical and Mechanical P.T. Components*

Charlotte, NC - USA  
1-800-825-6544

*For application assistance:*  
1-800-816-5608

### Bauer Gear Motor

*Geared Motors*

Esslingen, Germany  
+49 (711) 3518-0

### Nuttall Gear and Delroyd Worm Gear

*Worm Gear and Helical Speed Reducers*

Niagara Falls, NY - USA  
1-716-298-4100

## Overrunning Clutches

### Formsprag Clutch

*Overrunning Clutches and Holdbacks*

Warren, MI - USA  
1-800-348-0881 – Press #1

*For application assistance:*  
1-800-348-0881 – Press #2

### Marland Clutch

*Roller Ramp and Sprag Type Overrunning Clutches and Backstops*

South Beloit, IL - USA  
1-800-216-3515

### Stieber Clutch

*Overrunning Clutches and Holdbacks*

Heidelberg, Germany  
+49 (0) 6221 30 47 0

## Belted Drives and Sheaves

### TB Wood's

*Belted Drives*

Chambersburg, PA - USA  
1-888-829-6637 – Press #5

*For application assistance:*  
1-888-829-6637 – Press #7

## Engineered Bearing Assemblies

### Kilian Manufacturing

*Engineered Bearing Assemblies*

Syracuse, NY - USA  
1-315-432-0700

*For information concerning our sales offices in Asia Pacific check our website  
www.altramotion.com.cn*



**DISTRIBUIDOR  
AUTORIZADO**

MEX (55) 53 63 23 31  
QRO (442) 1 95 72 60

MTY (81) 83 54 10 18  
ventas@industrialmagza.com

[www.wichitaclutch.com](http://www.wichitaclutch.com)

2800 Fisher Road  
Wichita Falls, TX 76302 - USA  
940-723-3400  
Fax: 940-723-3436

[www.wichitaclutch.co.uk](http://www.wichitaclutch.co.uk)

Ampthill Road  
Bedford MK42 9RD - UK  
+44 (0) 1234 350311  
Fax: +44 (0) 1234 350317