

Packaged Electromagnetic Clutches/Brakes



Please see the following replacement catalogs:

**NEMA C-Face Compatible
Clutches, Brakes & Clutch
Brake Combinations**

P-8586-WE

**Shaft Mounted
Clutches & Brakes**

P-8587-WE

**Base Mounted Clutch/
Brake Combinations**

P-8588-WE

**Electrically Released
Spring-Set Brakes
& Unibrake AC Motor
Brakes**

P-8589-WE

**Permanent Magnet
Electrically Released
Brakes**

P-8590-WE



A Broad Range of Clutches, Brakes and Clutch/Brake Combinations

Warner Electric packaged performance products are electric clutches and brakes, assembled and aligned at the factory, to offer maximum start-stop performance combined with quick and easy installation. They are offered as clutches, brakes, and clutch/brake combinations in a wide range of sizes and torque ratings.

All packaged performance products have been designed to mate easily with industry standard motors, reducers, and other power transmission components. They can be foot mounted, shaft mounted, or installed on C-face motors and reducers.

Bolt-it-down, wire-it-up . . . they're ready to go. Most packaged performance products are recognized and/or listed by Underwriters Laboratories.

Contents

Product Line Overview

C-face Compatible Units	3
Shaft and Base Mounted Units	4
Electrically Released Brakes	5
UM (UniModule) GEN 2 Clutches and Brakes.....	7

C-face Compatible Units

Electro Modules

EM Series Modular Clutches, Brakes and Motor Brakes.....	24
--	----

UniModules

UM Smooth-Start	40
UM-C Series Ceramic Faced Clutch/Brakes	42

Enclosed UniModules

EUM Series Clutch/Brakes and Clutch Combinations	49
EUM-W Series Washdown Clutch/Brakes	59

Shaft and Base Mounted Units

Electro Clutches and Brakes

Features and Applications.....	67
EC Series Shaft Mounted Clutches	68
EB Series Shaft Mounted Brakes	74

Advanced Technology Clutches and Brakes

Features and Applications.....	80
ATC Series Clutches.....	84
ATB Series Brakes	88

Packaged Stationary Field Clutches

Features and Applications.....	90
SFP Clutches	91

Electro Pack

EP Series Base Mounted Clutch/Brakes	94
EP-C Series Ceramic Faced Base Mounted Clutch/Brakes	100
Washdown Electro Pack	104

Electrically Released Brakes

Spring-Set Brakes

Features and Applications.....	106
ERS Series Static Engaged Brakes	109
NEMA C-face EM/ERS Spring-Set Brake Modules	117
ERD Series Dual Purpose Engagement Brakes	121

Permanent Magnet Brakes

Features and Applications.....	134
FB Series Shaft Mounted Brakes	135
ER Series Flange Mounted Brakes.....	138

Permanent Magnet NEMA C-face Modules

Features and Applications.....	142
UM-FBC Series Clutch/Electrically Released Brakes.....	144
EUM-FBB and EUM-MBFB Series Enclosed UniModules	151
EM-FBB, EM-FBC and EM-MBFB Series Brake Modules	159

UNIBRAKE AC Motor Brakes

Features and Applications.....	170
F Series.....	172
M Series.....	182

Mechanical Data

Application Engineering	186
NEMA Frame Dimensions/Ordering Information	187
Dynamic Torque.....	188
Rotational Speed.....	190
Clutch Field Restraining Devices	191

Electrical Data

Coil Ratings	192
Installation Procedure.....	195
Coil Suppression and Clutch/Brake Overlap	196
Overexcitation.....	197

Bushing Part Numbers	198
----------------------------	-----

Application Data Form	200
-----------------------------	-----

Clutch/Brake Controls Table of Contents	201
---	-----

Service Parts Table of Contents.....	230
--------------------------------------	-----

Part Numbers/Ordering Information	304
---	-----

Index	310
-------------	-----



©2011 Warner Electric, Inc.

Packaged Performance Products

Electromagnetic Clutches and Brakes

Packaged Products Benefits

Warner Electric Packaged Products come pre-assembled, ready to install right out of the box.

Warner Electric Packaged Products consist of a single part number in most cases. One part number to inventory, one part number to track in your engineering system.

All Warner Electric packaged products incorporate our Autogap™ mechanism that automatically adjusts for wear. This eliminates the need for maintenance, but more importantly, it ensures the same engagement time cycle after cycle after cycle through the whole life of the unit ensuring consistent product manufacturing processes.

Warner Electric Packaged designs are available for:

- C-face mount applications
- Parallel shaft applications
- Base mount applications

The Basics

The electric clutch and brake has been called the best thing that ever happened to the electric motor. It's simple, electric clutches and brakes do all the work, while permitting motors to run smoothly and continuously at their most efficient speed by connecting/disconnecting the motor and the load. Fast starts and stops, easy control interface, remote pushbutton operation and smooth acceleration and deceleration are outstanding user benefits.

Reliable Performance

- High cycle rates
- Smooth soft starts
- Cushioned stops
- Accurate positioning
- Indexing
- Jogging
- Reversing
- Speed changing



Packaged Performance Products

Electromagnetic Clutches and Brakes

Principle of Operation

A key feature of Warner Electric brakes and clutches is the method of actuation. Like an electromagnet, they have two basic parts. A magnetic field is generated as soon as the current flows through the magnet coil. This draws the armature into direct contact with the magnet. The strength of the magnetic field is directly proportional to the amount of current applied. Full range torque control from 0 to 100% is as simple as turning the knob on a light dimmer.

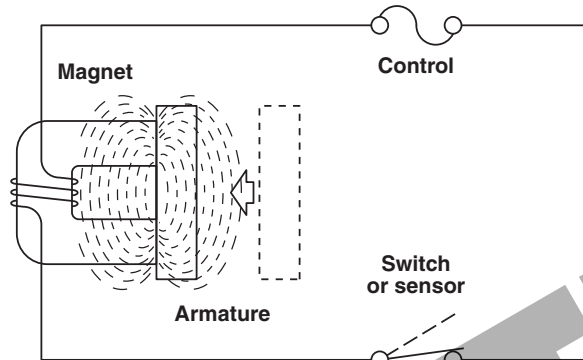

Fast and Accurate

The benefits of electric actuation combined with the use of small, low inertia components is fast response, high cycle rates, and increased accuracy. While other devices are often sluggish and slow to respond, electric brakes and clutches respond instantly, resulting in higher productivity and better consistency.

Controllable

Electric brakes and clutches are incredibly easy to control. The shift from positive, instantaneous engagement to soft, cushioned starts and stops is as simple as turning a knob.

Easy to Select

Most of the time, all you need to know is motor horsepower and the speed at the brake or clutch location. Warner Electric takes care of the rest. The performance you require is built in, and with the broad range of products to choose from, you won't have to compromise with a clutch or brake that's a little too big or a little too small.

Maintenance Free

Warner Electric brakes and clutches are clean and quiet. They require no maintenance. They never need lubrication, and they're completely self adjusting for wear. No complicated air system or messy hydraulics. Warner Electric brakes and clutches are outstandingly trouble free.

Torque/Current Curve

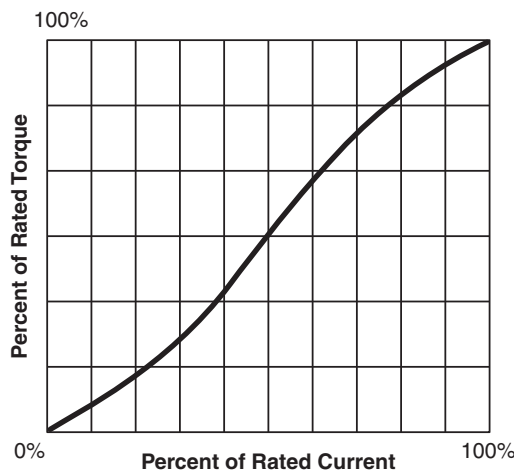

Packaged Performance Products

C-face Clutches and Clutch/Brake Assemblies

Electro Module

Individual Clutch and Brake Modules



EM Series

Page 24

Modular Components that are Easily Combined

- ❑ 5 sizes
- ❑ 16 clutch and brake modules
- ❑ 16 to 95 lb. ft. torque range

Individual modules may be used in combination to form clutches, brakes or clutch/brake packages.

Electro Modules can be bolted directly to NEMA C-face motors or reducers, or base mounted for stand alone operation.

Service Parts, see page 248.

UM Smooth-Start

Page 40

Soft Engage Designs

- ❑ 5 sizes
- ❑ 10-57 lb.ft. torque range

Smooth-Start designs allow for a soft engage clutch and brake without sacrificing unit life.

UniModule®

One Piece Preassembled Clutches and Clutch/Brakes



UM Series

Page 14

C-face or Base Mounted Units

- ❑ 5 sizes
- ❑ 20 combinations
- ❑ 16 to 95 lb. ft. torque range

UniModule clutches and clutch/brake packages offer the ultimate in installation convenience.

Can be motor or reducer mounted, or used as a separate drive unit powered from a prime mover.

Service Parts, see page 232.

UM-C Series

Page 42

High Performance Version for High Cycle Rate Applications

- ❑ 3 sizes
- ❑ 6 combinations
- ❑ 16 to 95 lb. ft torque range

The UM-C units are UniModules with ceramic faced components, specifically designed for long life, high energy, and high cycle rate applications.

Enclosed UniModule®

Preassembled Units Offer Clean, Quiet Operation



EUM Series

Page 49

Totally Enclosed Clutch and Brake Packages

- ❑ 5 sizes
- ❑ 3 combinations
- ❑ 16 to 95 lb. ft. torque range

Totally enclosed, rugged enclosure keeps wear particles in and contaminants out. Finned for rapid heat dissipation and long life.

Service Parts, see page 262.

EUM-W Series

Page 59

Washdown Version

- ❑ 5 sizes
- ❑ 8 combinations
- ❑ 16 to 95 lb. ft. torque range

The washdown version of the EUM uses stainless steel shafting, USDA approved coating, corrosion resistant fasteners and special seals.

Service Parts, see page 262.

See Page 7 for GEN 2 Information

Packaged Performance Products

Shaft and Foot Mounted Units

Electro Clutches Electro Brakes

Shaft Mounted Units



EC Series Clutches **Page 68**

Pre-Packaged Convenience

- ❑ 6 sizes
- ❑ 16 to 465 lb. ft. torque range

All the features of an electric clutch in a convenient, pre-packaged assembly. Mounts on any through shaft or extended motor shaft. Easy-to-assemble with standard sheaves, pulleys, gears and sprockets. Packaged design. No assembly required. Long life. No maintenance.

Service Parts, see page 270.

EB Series Brakes **Page 74**

Torque Arm Mounting

- ❑ 6 sizes
- ❑ 16 to 465 lb. ft. torque range

Torque arm feature makes Electro Brakes easy to mount on any motor or through shaft. Packaged design. No assembly required. Long life. No maintenance.

Service Parts, see page 276.

Advanced Technology Clutches and Brakes

Extra Rugged Design



ATC Series Clutches **Page 84** ATB Series Brakes **Page 88** Replaceable Friction Faces

- ❑ 3 sizes
- ❑ 25 to 115 lb. ft. torque range

Rugged, heavy duty units designed for extra long life and efficient operation. Cast components for durability. Finned armatures for high heat dissipation.

Friction faces are designed to allow for replacement without replacing valuable, non-wear components. Provides superior wear life with reduced engagement noise.

Service Parts, see page 282.

SFP Series Clutches **Page 90**

- ❑ Pre-assembled SF – No assembly required
- ❑ Ball bearing mounted field and armature
- ❑ 70 inch pound and 270 inch pound sizes
- ❑ Bore sizes from 3/8" to 1/2" and 1/2" to 1"

SFP clutches provide the simplicity and cost efficiency of the Basic SF design, but with a ball bearing mounted armature hub.

Electro Pack Clutch/Brakes

Foot Mounted Units



EP Series **Page 94**

Totally Enclosed Units

- ❑ 8 sizes
- ❑ 15 lb. to 1350 lb. ft. torque range

Electro Packs are rugged, pre-assembled clutch and brake combinations in enclosed, foot mounted housings.

Service Parts, see page 286.

EP-C Series **Page 100**

High Performance Version

- ❑ 2 sizes
- ❑ 15 and 70 lb. in. torque

Ceramic faced wear components provide long life for high cycle rate use. Consistent torque and cycle repeatability with Smooth-Start/stop control.

EP-W Series **Page 104**

Washdown Design

- ❑ 2 sizes
- ❑ 70 and 270 lb. in. static torque ranges
- ❑ USDA approved coating
- ❑ Stainless steel shaft and hardware
- ❑ Available in 24 or 90 volt DC

Electrically Released Brakes

Spring-Set Brakes

For Power-Off Static Holding and Emergency Stopping Applications

WARNING For general use in horizontal shaft applications only. For possible vertical applications, contact technical support.



ERS Series

Page 109

Static Engaged

- ❑ 5 sizes
- ❑ 1.5 to 100 lb. ft. holding torque

Designed for static holding, ERS models feature multiple coil springs that force armature and friction faces together to generate braking torque when power is off. The Electromagnet counters the spring force to disengage the brake when power is applied.

Although this brake should be engaged only when the shaft is at rest, it can occasionally act as a dynamic braking device to stop a rotating load in an emergency situation.

Spring Set Brake Module

Page 117

- ❑ 7 to 100 lb. ft. holding torque

NEMA C-face version of the ERS Series

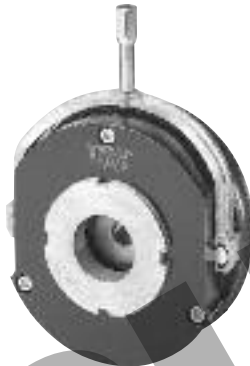

ERD Series

Page 121

Dynamic Braking

- ❑ 8 sizes
- ❑ 4 to 221 lb. ft. holding torque

ERD units are electrically released, static and dynamic engaged, spring-set brakes for power-off load holding applications. These spring-set brakes automatically stop and hold a load in the event of a power failure or other emergency stop situations. Fully dynamic friction material allows for repeated braking cycles from full motor speed with no torque fade. An optional manual release allows the brake to be released by hand.

Unibrake Series

Page 170

AC Motor Brakes

- ❑ Spring Set/Solenoid Released
- ❑ Direct acting/manual release standard 3 families
- ❑ 3, 6, 10 and 15 lb. ft. capacity
- ❑ Steel or cast iron covers
- ❑ Rear mount or double C-face designs

Permanent Magnet Brakes

For Power-Off Dynamic Stopping and Cycling Applications

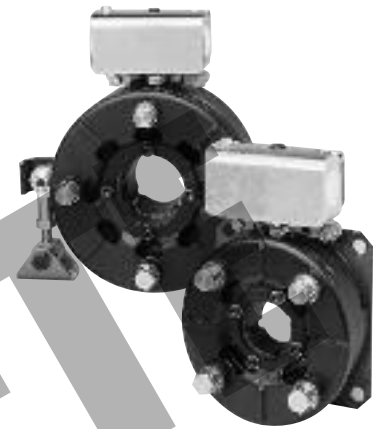

FB Series

Page 135

Shaft Mounted, Dynamic Braking

- ❑ 3 models
- ❑ 10.5 to 56 lb. ft. static torque

Permanent magnet brakes are designed to dynamically stop and hold a moving load and also for high cycle rate stopping. Electric power to the coil nullifies the attraction of the permanent magnet, releasing the brake.

FB models are pre-assembled and feature a torque arm for convenient shaft mounting.

Service Parts, see page 294.

ER Series

Page 138

Flange Mounted, Dynamic Braking

- ❑ 5 models
- ❑ 10.5 to 400 lb. ft. static torque

The ER style brake offers a bulk head flange mounting system, the highest torque rating offered by Warner Electric in the power released series, high cycle rate capability, and excellent life. They require some assembly.

Service Parts, see page 296.

Packaged Performance Products

Electrically Released Module Brakes

Permanent Magnet, Power-Off Brakes

C-face Brake Modules



Electro Module **Page 159**

Individual Module Components **EM-FBC (Clutch/Brakes)**

- ❑ 3 sizes
- ❑ 10.5 to 56 lb. ft. torque range

Used in combination with an Electro Module motor or input clutch module for clutch/brake applications. Electrical power applied to the brake coil nullifies the permanent magnets' force and the brake releases. No springs to limit cycle rates.

EM-FBB (Brake Modules)

- ❑ 5 sizes
- ❑ 10.5 to 56 lb. ft. torque range

Use for brake alone applications. Mounts between a C-face motor and reducer. Recommended for dynamic cycling operations only.

EM-MBFB (Motor Brakes)

- ❑ 4 sizes
- ❑ 56C to 215C frame motors

Mounts to the back of a double shafted C-face motor. Never needs adjustment or lubrication.

UniModule **Page 144**

One Piece Packages **UM-FBC (Clutch/Brakes)**

- ❑ 4 sizes
- ❑ 7 combinations
- ❑ 10.5 to 56 lb. ft. static brake torque

UniModule pre-assembled clutch and electrically released brake packages are available in both C-face and base mounted versions.

Unique design employs powerful permanent magnets for maximum torque when power is removed from the brake coil. A small amount of electrical power applied to the brake coil nullifies the permanent magnets and the brake releases. No springs to limit cycle rates. Never any adjustment. No lubrication. These brakes are recommended for dynamic cycling operations only.

Enclosed UniModule **Page 151**

Totally Enclosed **EUM-FBB (Brake Modules)**

- ❑ 4 sizes
- ❑ 6 to 32 lb. ft. static torque

Totally enclosed UniModule electrically released brake packages keep contaminants out and wear particles in for clean, quiet operation. Assembly, alignment, and preburnishing have been done at the factory. Use for brake alone applications, mountings between a motor and a gear reducer. Select the torque required for the application. Higher torque brakes stop loads faster. Lower torque models provide softer stopping to prevent boxes on conveyors from tipping or skidding.

EUM-MBFB (Motor Brakes)

- ❑ 4 sizes
- ❑ 56C to 215C frame motors

UniModule motor brakes are used for dynamic stopping and holding of loads when power is removed from the motor. Typical applications include conveyors, process equipment, and lifting devices. Mounts to a double shafted C-face motor.

See Page 7 for GEN 2 Information

The next evolution in Module Brake Technology is available today from Warner Electric

Warner Electric designed and patented the first electromagnetic clutch/brake more than 70 years ago and has pioneered most significant advances in the field since then including the introduction of the single piece UniModule in 1989.

Today, new technologies in the areas of design, materials and manufacturing have helped us develop our new **GEN 2** clutches and brakes which incorporate several changes that affect unit appearance and performance without affecting unit fit or wiring requirements.

Many models within our Packaged Clutch and Brake product offering are now available in the new **GEN 2** design. These units contain many shared parts while still meeting our high manufacturing standards and performance characteristics.

GEN 2... the latest example of how Warner Electric continues to lead the industry through innovation, service, and reliability.

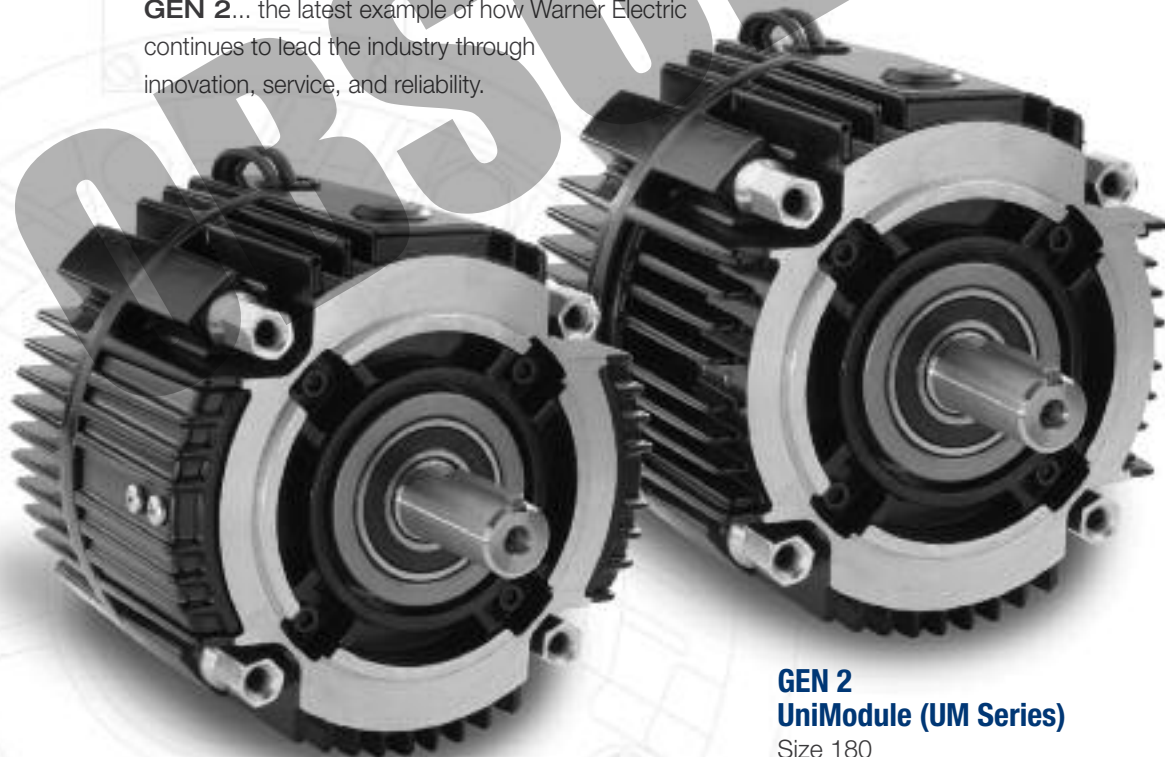

GEN 2
Enclosed UniModule (EUM Series)
Size 180

With optional Cover Kit (containing 2 covers and 4 screws) which converts a UniModule to an enclosed (non-washdown) design

GEN 2
UniModule (UM Series)
Size 180

With open housing vents (standard)

GEN 2 Clutches and Brakes

GEN 2 units are direct replacements for original models

GEN 2 Design













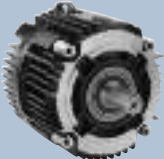



- Wiring and cycling are not affected by the new design
- Conduit box positions directly vertical on the top of the unit instead of 15° or 60° off of vertical
- Rotor set screw access is improved for easier installation
- Use of integrated mounting bolts make installation easier and faster



Original Design

GEN 2 Clutches and Brakes

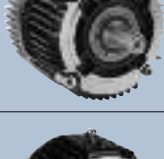
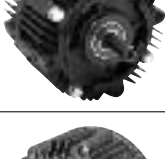
Only 50, 100, and 180 sizes of the models listed below will be converted to the new GEN 2 design. 210 and 215 sizes will continue to be offered only in the original design and will not be converted.

Pages	C-face Compatible Units	GEN 2 Models		Original Design Models	
			Sizes		Sizes
12–23	UniModules (UM Series) Enclosed UniModules (EUM Series)		50 100 180		210 215
24–39	Electro Modules (EM Series) Enclosed Option		50 100 180		210
40–41	Smooth-Start Modules		50 100 180		210 215
42–48	UniModules – Ceramic Faced (UM-C Series) Electrically Released Units		50 100 180		210
117–120	Spring Set Brake Modules (EM/ERS Series)		50 180		210
144–150	UniModules (UM-FBC Series)		50 100 180		210 215
151–158	Enclosed UniModules (EUM-FBB, MBFB Series)				
159–169	Electro Modules (EM-FBB, FBC, MBFB Series) Enclosed Option		50 100 180		210 215
	Enclosed UniModules - Washdown (EUM-W Series)				

GEN 2 Clutches and Brakes

Ordering
GEN 2 models is easy...

Selected models (50,100, and 180 sizes)
highlighted in blue tint throughout this catalog
have been converted to the new GEN 2 design

Part Numbers

(Blue shaded areas indicate GEN 2 design)

Model No.	Voltage D.C.	GEN 2 Part No.	Original Part
1020 Motor Clutch/Brake			
UM-50-1020	6	5370-273-201	5370-273-016
UM-50-1020	24	5370-273-203	5370-273-018
UM-50-1020	90	5370-273-204	5370-273-017
UM-100-1020	6	5370-273-206	5370-273-026
UM-100-1020	24	5370-273-208	5370-273-028
UM-100-1020	90	5370-273-209	5370-273-027
UM-180-1020	6	5370-273-211	5370-273-006
UM-180-1020	24	5370-273-213	5370-273-008
UM-180-1020	90	5370-273-214	5370-273-007
UM-210-1020	6		5371-273-002
UM-210-1020	24		5371-273-004
UM-210-1020	90		5371-273-003
UM-15-1020	6		5371-273-076
UM-15-1020	24		5371-273-077
UM-15-1020	90		5371-273-078

Only 50, 100, and 180 sizes of the models listed will be converted to the new GEN 2 design. 210 and 215 sizes will continue to be offered in the original design and will not be converted.

Model No.	Voltage D.C.	GEN 2 Part No.	Original Part
3040 Input Clutch Output Clutch			
UM-50-3040	6	5370-271-216	5370-271-009
UM-50-3040	24	5370-271-218	5370-271-011
UM-50-3040	90	5370-271-219	5370-271-010
UM-100-3040	6	5370-271-221	5370-271-029
UM-100-3040	24	5370-271-223	5370-271-031
UM-100-3040	90	5370-271-224	5370-271-030
UM-180-3040	6	5370-271-226	5370-271-019
UM-180-3040	24	5370-271-228	5370-271-021
UM-180-3040	90	5370-271-229	5370-271-020
UM-210-3040	6		5371-271-007
UM-210-3040	24		5371-271-009
UM-210-3040	90		5371-271-008
UM-215-3040	6		5371-271-021
UM-215-3040	24		5371-271-022
UM-215-3040	90		5371-271-023

Model No.	Voltage D.C.	GEN 2 Part No.	Original Part
Motor Clutch Output Clutch			
UM-1040	6	5370-271-201	5370-271-004
UM-1040	24	5370-271-203	5370-271-006
UM-1040	90	5370-271-204	5370-271-005
UM-1040	6	5370-271-206	5370-271-024
UM-1040	24	5370-271-208	5370-271-026
UM-1040	90	5370-271-209	5370-271-025
UM-1040	6	5370-271-211	5370-271-014
UM-1040	24	5370-271-213	5370-271-016
UM-1040	90	5370-271-214	5370-271-015
UM-1040	6		5371-271-002
UM-1040	24		5371-271-004
UM-1040	90		5371-271-003
UM-1040	6		5371-271-026
UM-1040	24		5371-271-027
UM-1040	90		5371-271-028

Accessories

Description	UM Size	Part No.
Conduit Box	All sizes	
Base Mount Kit for 2030, 3040	50/100	5370-101-042
	180	5370-101-004
	210/215	5370-101-002
Motor Mount Kit for 1020, 1040	50/100	5371-101-001
	180	5370-101-078
Cover Kit	210/215	5370-101-079
	50/100/180	5371-101-012
		5370-101-076

Non tinted, original design models

210 and 215 sizes will continue to be offered only in the original design and will not be converted.

How to Order

Motor or Reducer Mounted

Simply combine the size number with the configuration of the required UniModule. Specify voltage. See chart for specific part numbers. Power-off brake UniModules are found on page 106. Order optional conduit box if desired.

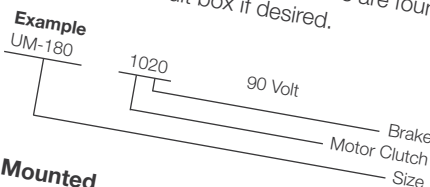

Base Mounted

Simply combine the size number with the configuration of the required UniModule. Specify voltage. See chart for specific part numbers. Power-off brake UniModules are found on page 106. Order optional conduit box if desired.

GEN 2 models share the same specifications with original design models but have different dimensions and a modified conduit box location.

New Conduit Box Location

The difference is shown on dimension drawings throughout this catalog. Conduit box positions directly vertical on the top of the unit instead of 15° or 60° off of vertical.

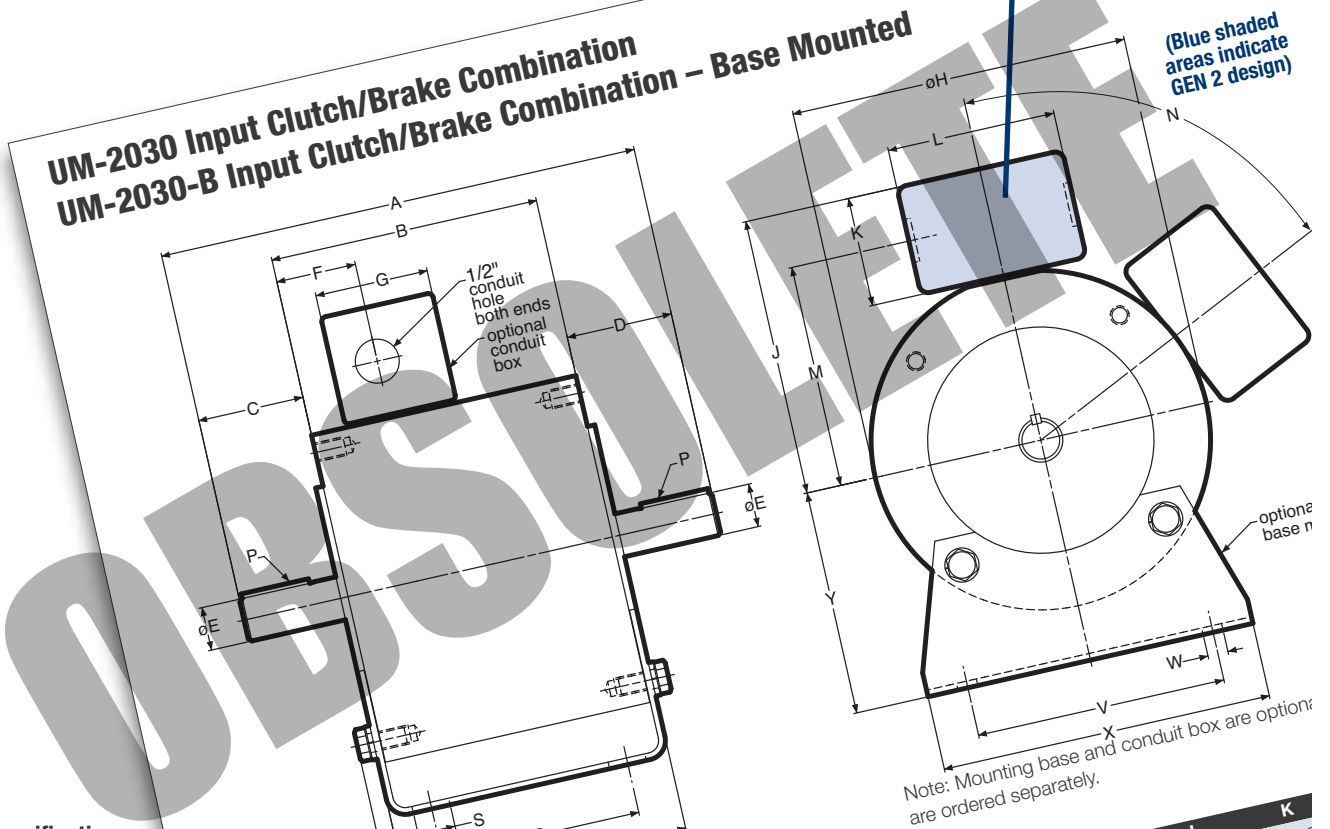

Same Specifications

All original design unit specifications are the same for the new GEN 2 models.

Note that new GEN 2 simplified dimension drawings on the right show only outline footprints of models with no internal details.

Dimensions (Blue shaded areas indicate GEN 2 design)

Size	A	B	C	D	E	F	G	H	J	K
50	9.492	5.390	2.062	2.040	.625	1.600	2.267	6.750	5.516	2.180
100	9.512	5.390	2.061	2.061	.625	1.600	2.267	6.750	5.516	2.180
180	9.632	5.390	2.121	2.121	.875	1.600	2.267	6.750	5.516	2.180
210	12.969	7.719	2.500	2.500	1.125	1.812	2.267	9.250	6.859	2.180
215	12.969	7.719	2.500	2.500	1.375	1.812	2.267	9.250	6.859	2.180

Specifications (Blue shaded areas indicate GEN 2 design)

Size	N	P	R	S	T	U	V	W	X
50	0°	3/16 x 3/16	4.000	.800	5.680	.329	5.000	.406	6.000
100	0°	3/16 x 3/16	4.000	.800	5.680	.329	5.000	.406	6.000
180	0°	3/16 x 3/16	4.000	.750	5.680	.329	5.000	.406	6.625
210	65°	1/4 x 1/4	6.000	.750	8.260	.437	7.750	.534	9.000
215	65°	5/16 x 5/16	6.000	.750	8.260	.437	7.750	.534	9.000

Packaged Performance Products

Original Design

210 and 215 sizes

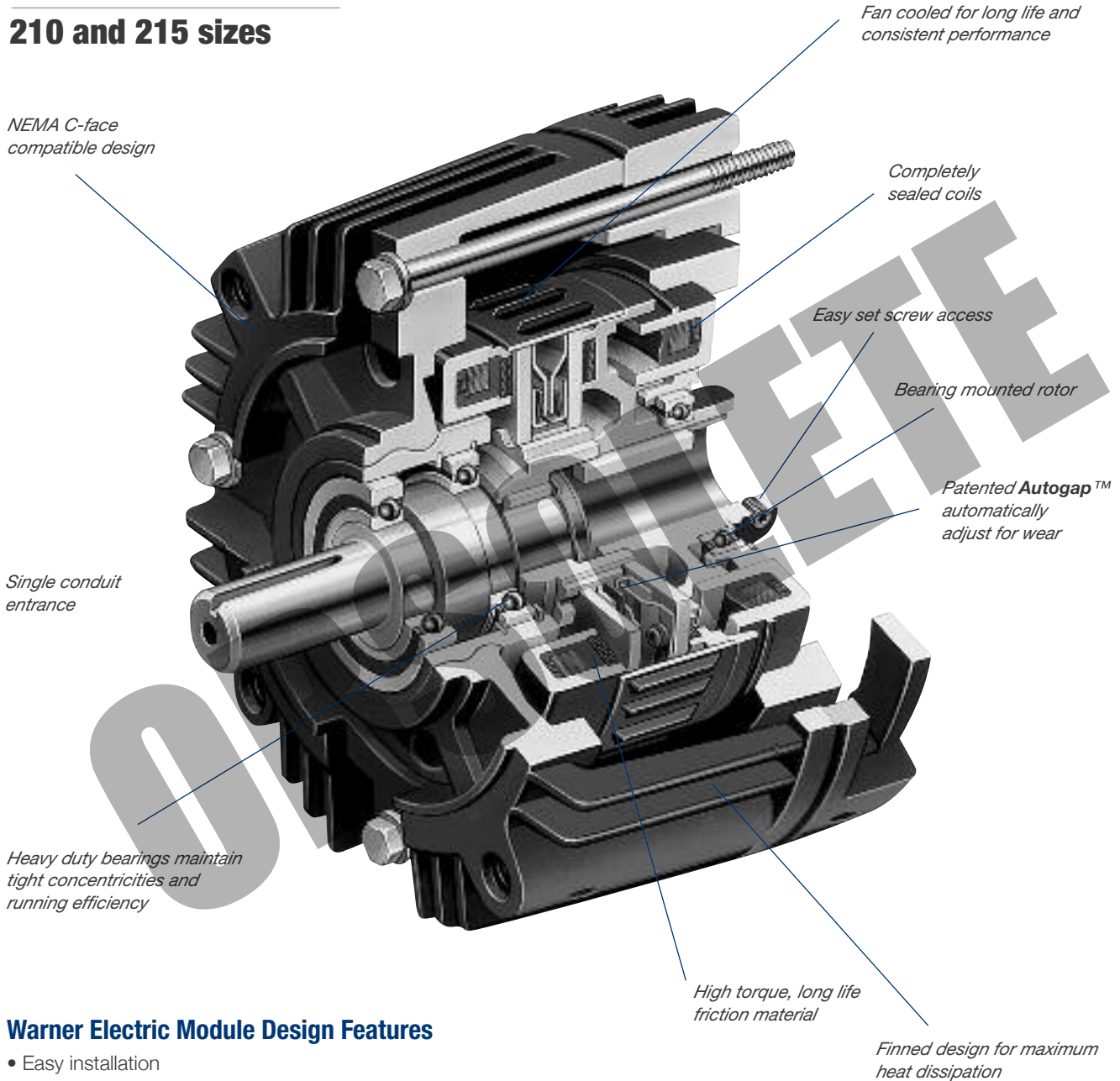

Warner Electric Module Design Features

- Easy installation
- Available with standard power-on and electrically released power-off brake units
- Fan cooled for high cycle rate operation
- Maintenance Free
- UL listed
- Can be applied with control fitted as standard
- Bearing mounted clutch rotor eases assembly alignment
- Single access hole for all wires

GEN 2 Design

50, 100, and 180 sizes

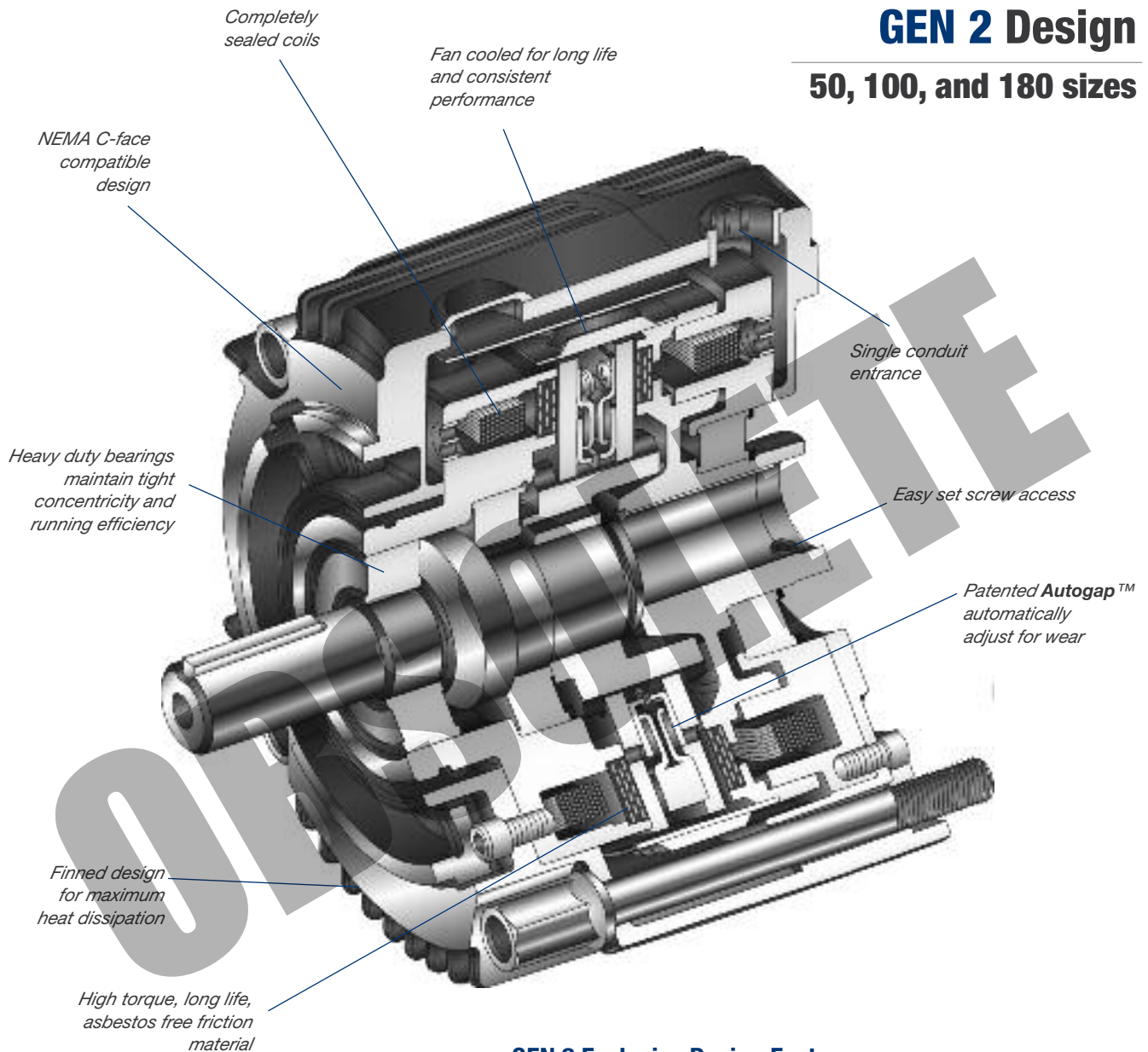

GEN 2 Exclusive Design Features

- Internal component changes make installation easier and faster
- Symmetric housing fin design increases heat dissipation capacity
- Available only in 50, 100, and 180 sizes, NEMA C-face design
- Conduit box relocation simplifies installation. Use of integrated mounting bolts allows for conduit box location directly on the top of the unit
- Available field installed conversion kit creates a totally enclosed clutch/brake package without the need to replace entire unit
- New design allows for more efficient assembly which yields greater availability and shorter lead times
- Improved input to output axis design reduces vibration and improves noise and wear factors
- Heavy-duty models available with increased spline length and higher load capacity bearings.



UM Series UniModule

Pre-assembled, C-face Clutches and Brakes

UniModules offer the ultimate in Clutch/ Brake performance and convenience. UniModules offer the same performance as EM's without the assembly required.

Completely pre-assembled one-piece clutch and clutch/brake packages in five sizes. Can be motor or reducer mounted or used as a separate drive unit powered by a prime mover.

Pre-assembled, pre-aligned, and pre-burnished at the factory for rated torque directly out-of-the-box.

- Easy installation
- Available with standard power-on and electrically released power-off brake units
- Fan cooled for high cycle rate operation
- Maintenance Free
- Available in 50, 100, 180, 210, and 215 sizes. NEMA C-face design
- UL listed
- Can be applied with control fitted as standard
- Bearing mounted clutch rotor eases assembly alignment
- Single access hole for all wires

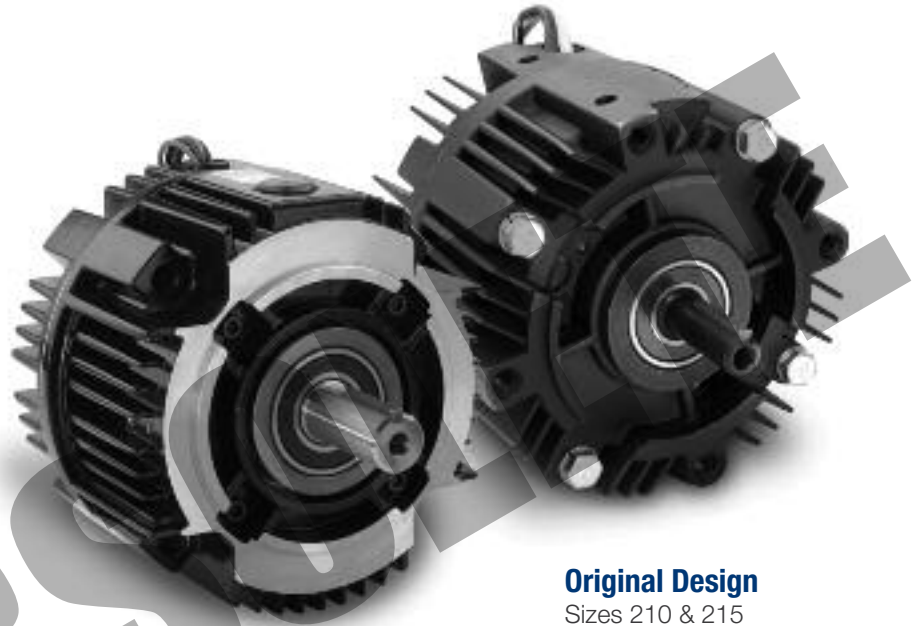

GEN 2 Design
Sizes 50, 100 & 180

Original Design
Sizes 210 & 215

Clutch Combinations



1040

Motor Clutch/Output Clutch

Use for clutch only applications. Has hollow bore input for mounting directly to C-face motors. Shaft and C-face on output side of unit accommodates reducer, parallel drive or coupling. Motor Clutch is fan cooled for long life and consistent performance. Basic components are field, rotor and armature. See page 21 in this catalog.



3040

Input Clutch/Output Clutch

Use for clutch only applications. Features dual C-faces and shafts. Unit input from parallel drive or coupling. Output to reducer. Input Clutch is fan cooled and has sealed coil. Twin bearing mounted shafts maintain tight concentricities. The Output Clutch utilizes Autogap™ which automatically adjusts armature for wear. Basic components are field, rotor and armature. See page 23 in this catalog.



3040-B

Input Clutch/Output Clutch – with Accessory Base Mounting

Base mounting allows the clutch unit to be utilized as a separate drive unit. Attach with pulleys, sprockets, etc. See page 23 in this catalog.

Clutch/Brake Combinations



1020

Motor Clutch/Brake

Use for clutch/brake applications. Has hollow bore input for mounting directly to C-face motors. Brake shaft and C-face on output side accommodate a reducer, parallel drive or coupling. Basic components: field, rotor, 2 armatures and power-on magnet. See page 20 in this catalog.

Heavy-duty models available with increased spline length and higher load capacity bearings.



2030

Input Clutch/Brake

Use for clutch/brake applications. Features dual C-faces and shafts. Input from parallel drive or coupling. Output to reducer. Basic components are field, rotor, 2 armatures and power-on magnet. See page 22 in this catalog.



2030-B

Input Clutch/Brake – with Accessory Base Mounting

Base mounting allows the clutch/brake units to be utilized as a separate drive unit. Attach with pulleys, sprockets, etc. See page 22 in this catalog.

UM Series UniModule

Selection

UniModule clutch, brake and clutch/brake units may be mounted directly to NEMA C-face motors and reducers, or can be base mounted.

1. Select Configuration

a. NEMA C-face Mounting

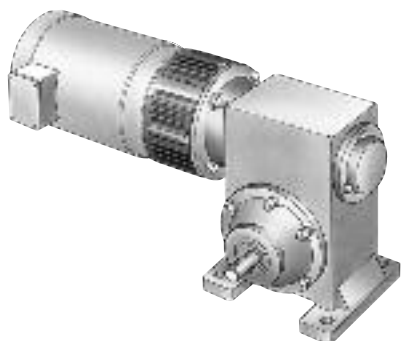

To select the correct UniModule package, determine the NEMA frame size of your motor and/or reducer, and choose the corresponding size UniModule from the Frame Size Selection chart.

Size UM-100 modules utilize a 5/8" diameter shaft to fit 56C/48Y motor frames with components of UM-180 units for higher torque and heat dissipation capacity than the UM-50.

UM-100 modules are available in 1020 and 2030 clutch/brake and 1040 and 3040 clutch configurations. For C-face mounting, select either a 1020 clutch/brake or a 1040 clutch configuration. The 2030 and 3040 configurations are for base mounting.

Frame Size Selection

NEMA Frame Size	UniModule Size
56C/48Y	UM-50* UM-100**
182C/143TC 184C/145TC	UM-180
213C/182TC 215C/184TC	UM-210
213TC/215TC	UM-215

* For 56C/48Y Frame motors 3/4 HP and smaller the UM-100 size may be used where extended life is desirable.
 ** UM-100 size is recommended for motors 1 HP and larger.

b. Base Mounting

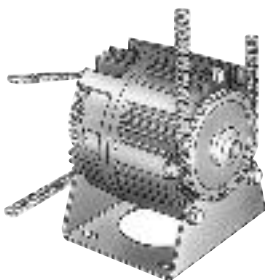

UniModule assemblies may be mounted as separate drive units driven from the prime mover by V-belts, chain and sprockets, couplings, timing belts and other standard power transmission components.

Select the correct size module from the Horsepower vs. Shaft Speed chart by determining the motor horsepower and RPM at the module location. The correct size UniModule is shown at the intersection of the HP and operating speed.

For additional sizing information, refer to the technical sizing procedure (step 2).

2. Determine Technical Requirements

Technical considerations for sizing and selection are torque and heat dissipation. Each merits careful consideration, especially heat dissipation as over time, use in excessive temperature environments will have an adverse effect on bearing life and coil wire insulation integrity.

Compare the calculated torque requirement with the average dynamic torque ratings. Select a unit with adequate torque. If the unit selected on torque is different than the unit selected based on heat, select the larger size unit.

Horsepower vs. Shaft Speed

HP	SHAFT SPEED AT CLUTCH (IN RPM)																	
	100	200	300	400	500	600	700	800	900	1000	1100	1200	1500	1800	2000	2400	3000	3600
1/4																		
1/2																		
3/4																		
1																		
1-1/2																		
2																		
3																		
5																		
7-1/2																		

a. Heat Dissipation Sizing

Friction surfaces slip during the initial period of engagement and, as a result, heat is generated. The clutch/brake selected must have a heat dissipation rating greater than the heat generated by the application. Therefore, in high inertia or high cycle rate applications, it is necessary to check the heat dissipation carefully. Inertia, speed and cycle rate are the required parameters.

Heat dissipation requirement is calculated as follows:

$$E = 1.7 \times WR2 \times (N/100)^2 \times F$$

where:

$$E = \text{Heat (lb. ft./min.)}$$

WR2 = Total reflected inertia at the clutch/brake shaft. Include the clutch/brake output inertia. (lb.ft.²)

N = Speed in revolutions per minute. (RPM)

F = Cycle rate in cycles per minute (CPM)

Compare the calculated heat generated in the application to the unit ratings using the heat dissipation curves. Select the appropriate unit that has adequate heat dissipation ability.

Heat Dissipation Curves

Size 50

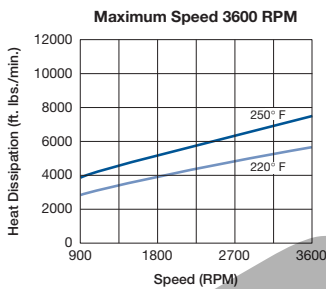

Size 100/180

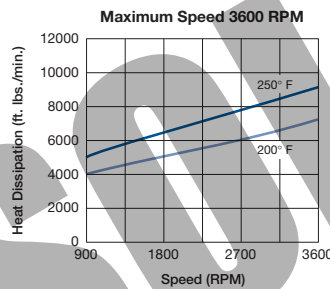

Size 210/215

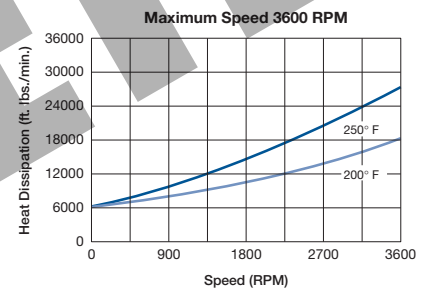

b. Torque Sizing

For most applications, the correct size clutch/brake can be selected from the Horsepower vs. Shaft Speed chart on page 16. Determine the motor horsepower and the RPM at the clutch/brake. The correct size unit is shown at the intersection of horsepower and shaft speed.

If the static torque requirements are known, refer to the technical ratings chart to select a unit.

For some applications, the torque requirement is determined by the time allowed to accelerate and decelerate the load. (This time is generally specified in milliseconds.) For these applications, it is necessary to determine the torque requirement based on load inertia and the time allowed for engagement.

The torque requirements are calculated as follows:

$$T = (WR2 \times N) / (308 \times t)$$

where:

T = Average Dynamic Torque (lb. ft.)

WR2 = Total reflected inertia at the clutch/brake shaft. Include the clutch/brake output inertia. (lb. ft.²)

N = Speed in revolutions per minute. (RPM)

t = Time allowed for the engagement (sec)

C-face Clutch/Power-on Brake Dynamic Torque Curves

Size 50

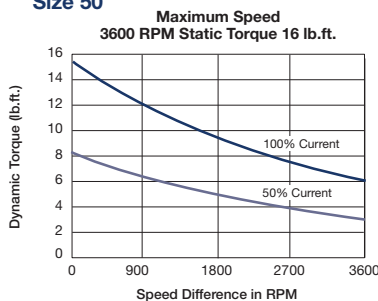

Size 100/180

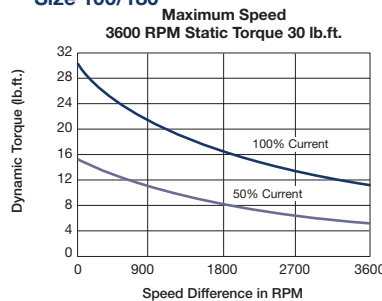

Size 210/215

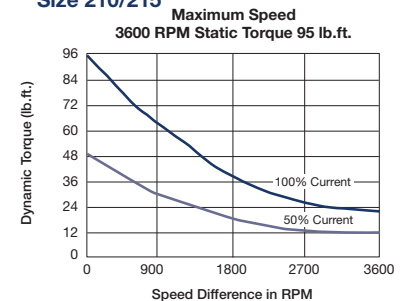

UM Series UniModule

Specifications (Blue shaded areas indicate GEN 2 design)

UM Size	Static Torque lb. ft.	Maximum RPM	Voltage DC
50	16	3600	6, 24, or 90
100	30	3600	6, 24, or 90
180	30	3600	6, 24, or 90
210	95	3600	6, 24, or 90
215	95	3600	6, 24, or 90

3. Accessories

Warner Electric UniModules can be fitted with several accessories to extend their capacity and ease of mounting.

a. Conduit Box

NEMA 4 and UL listed, available in standard and washdown versions.



b. Mounting Brackets

Two styles of mounting brackets are available for simplified installation. The base mount is used with the 2030 and 3040 configurations. A motor mount is also available and provides sturdy support for 1020 and 1040 units and a motor.

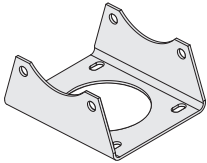

Base Mount

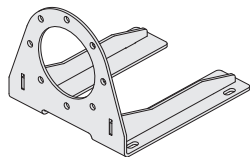

Motor Mount
For 50, 100 & 180 sizes

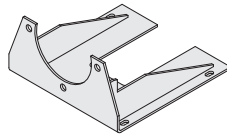

Motor Mount
For 210 & 215 sizes

c. Cover Kit – For sizes 50, 100 & 180



Each cover kit includes two (2) vent covers, two (2) gaskets and four (4) screws needed to convert a vented design into an enclosed design (non-washdown).

4. Select Control

Warner Electric manufactures clutch/brake controls to meet several system functions including:

- On/Off
- Torque adjust
- Over excitation
- Position loop

Many requirements beyond function can impact control selection. See the Controls Section on page 201 for complete information.

Model No.	Voltage D.C.	GEN 2 Part No.	Original Part No.	
UM-1020 w/Pre-installed control				
UM50-1020	w/CBC-150-1	90	5370-273-230	5370-9
UM100-1020	w/CBC-150-1	90	5370-273-231	5370-10
UM180-1020	w/CBC-150-1	90	5370-273-232	5370-273-122
UM180-1020 (heavy-duty)	w/CBC-150-1	90	5370-273-324	
UM210-1020	w/CBC-150-1	90		5371-4
UM215-1020	w/CBC-150-1	90		5371-273-090

Ordering Information

Part Numbers

(Blue shaded areas indicate GEN 2 design)

Only 50, 100, and 180 sizes of the models listed will be converted to the new GEN 2 design. 210 and 215 sizes will continue to be offered in the original design and will not be converted.

Model No.	Voltage D.C.	GEN 2 Part No.	Original Part No.
1020 Motor Clutch/Brake			
UM-50-1020	6	5370-273-201	5370-273-016
UM-50-1020	24	5370-273-203	5370-273-018
UM-50-1020	90	5370-273-204	5370-273-017
UM-100-1020	6	5370-273-206	5370-273-026
UM-100-1020	24	5370-273-208	5370-273-028
UM-100-1020	90	5370-273-209	5370-273-027
UM-180-1020	6	5370-273-211	5370-273-006
UM-180-1020	24	5370-273-213	5370-273-008
UM-180-1020	90	5370-273-214	5370-273-007
UM-210-1020	6		5371-273-002
UM-210-1020	24		5371-273-004
UM-210-1020	90		5371-273-003
UM-215-1020	6		5371-273-076
UM-215-1020	24		5371-273-077
UM-215-1020	90		5371-273-078
Heavy-Duty Models			
UM-180-1020	90	5370-273-323	
UM-180-1020*	90	5370-273-324	
1040 Motor Clutch Output Clutch			
UM-50-1040	6	5370-271-201	5370-271-004
UM-50-1040	24	5370-271-203	5370-271-006
UM-50-1040	90	5370-271-204	5370-271-005
UM-100-1040	6	5370-271-206	5370-271-024
UM-100-1040	24	5370-271-208	5370-271-026
UM-100-1040	90	5370-271-209	5370-271-025
UM-180-1040	6	5370-271-211	5370-271-014
UM-180-1040	24	5370-271-213	5370-271-016
UM-180-1040	90	5370-271-214	5370-271-015
UM-210-1040	6		5371-271-002
UM-210-1040	24		5371-271-004
UM-210-1040	90		5371-271-003
UM-215-1040	6		5371-271-026
UM-215-1040	24		5371-271-027
UM-215-1040	90		5371-271-028
2030 Input Clutch/Brake			
UM-50-2030	6	5370-273-216	5370-273-021
UM-50-2030	24	5370-273-218	5370-273-023
UM-50-2030	90	5370-273-219	5370-273-022
UM-100-2030	6	5370-273-221	5370-273-031
UM-100-2030	24	5370-273-223	5370-273-033
UM-100-2030	90	5370-273-224	5370-273-032
UM-180-2030	6	5370-273-226	5370-273-011
UM-180-2030	24	5370-273-228	5370-273-013
UM-180-2030	90	5370-273-229	5370-273-012
UM-210-2030	6		5371-273-007
UM-210-2030	24		5371-273-009
UM-210-2030	90		5371-273-008
UM-215-2030	6		5371-273-043
UM-215-2030	24		5371-273-044
UM-215-2030	90		5371-273-045

* Includes CBC-150-1

Model No.	Voltage D.C.	GEN 2 Part No.	Original Part No.
3040 Input Clutch Output Clutch			
UM-50-3040	6	5370-271-216	5370-271-009
UM-50-3040	24	5370-271-218	5370-271-011
UM-50-3040	90	5370-271-219	5370-271-010
UM-100-3040	6	5370-271-221	5370-271-029
UM-100-3040	24	5370-271-223	5370-271-031
UM-100-3040	90	5370-271-224	5370-271-030
UM-180-3040	6	5370-271-226	5370-271-019
UM-180-3040	24	5370-271-228	5370-271-021
UM-180-3040	90	5370-271-229	5370-271-020
UM-210-3040	6		5371-271-007
UM-210-3040	24		5371-271-009
UM-210-3040	90		5371-271-008
UM-215-3040	6		5371-271-021
UM-215-3040	24		5371-271-022
UM-215-3040	90		5371-271-023

Accessories

Description	UM Size	Part No.
Conduit Box	All sizes	5370-101-042
Base Mount Kit	50/100	5370-101-004
	180	5370-101-002
	210/215	5371-101-001
Motor Mount Kit	50/100	5370-101-078
	180	5370-101-079
	210/215	5371-101-012
Cover Kit	50/100/180	5370-101-076

How to Order

Motor or Reducer Mounted

Simply combine the size number with the configuration of the required UniModule. Specify voltage. See chart for specific part numbers. Power-off brake UniModules are found on page 106. Order optional conduit box if desired.

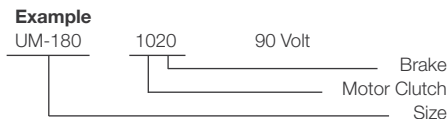

Base Mounted

Simply combine the size number with the configuration of the required UniModule. Specify voltage. See chart for specific part numbers. Power-off brake UniModules are found on page 106. Order optional conduit box if desired.

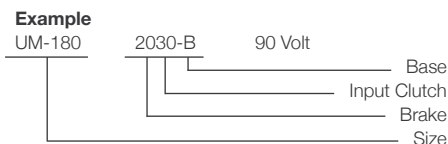

Select Appropriate Power Supply/Control.

UM Series UniModule

UM-1020 Motor Clutch/Brake Combination

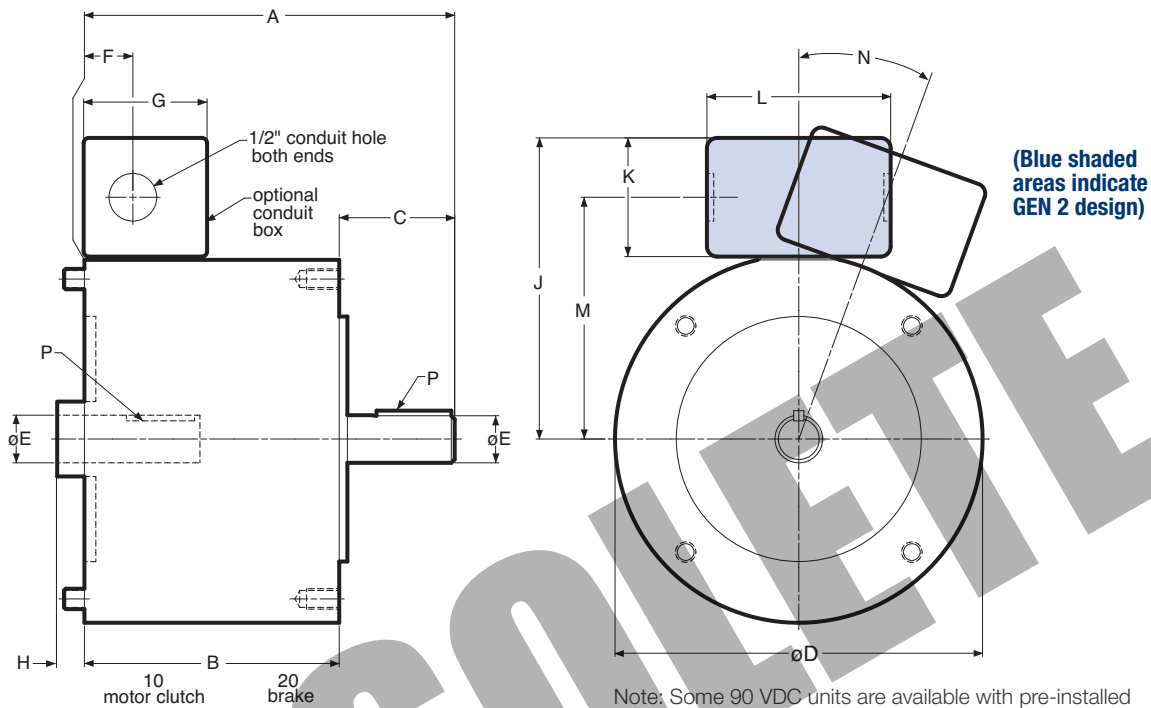

(Blue shaded areas indicate GEN 2 design)

Note: Some 90 VDC units are available with pre-installed controls. On all other modules, conduit box is optional and is ordered separately.

Dimensions (Blue shaded areas indicate GEN 2 design)

Size	A	B	C	D	E	F	G	H
50	6.720	4.680	2.040	6.750	.625	.890	2.267	—
100	6.741	4.680	2.061	6.750	.625	.890	2.267	—
180	6.801	4.680	2.121	6.750	.875	.890	2.267	—
210	8.891	5.922	2.500	9.250	1.125	.500	2.267	.500
215	9.391	5.922	3.000	9.250	1.375	.500	2.267	.500

Size	J	K	L	M	N	P
50	5.516	2.180	3.250	4.426	0°	3/16 x 3/16
100	5.516	2.180	3.250	4.426	0°	3/16 x 3/16
180	5.516	2.180	3.250	4.426	0°	3/16 x 3/16
210	6.859	2.180	3.250	5.766	20°	1/4 x 1/4
215	6.859	2.180	3.250	5.766	20°	5/16 x 5/16

Specifications (Blue shaded areas indicate GEN 2 design)

Model Size	Voltage DC	Static Torque lb. ft.	Max. RPM	NEMA Frame Size
50	6, 24, 90	16	3600	56C/48Y*
100	6, 24, 90	30	3600	56C/48Y**
180	6, 24, 90	30	3600	182C/143TC 184C/145TC
210	6, 24, 90	95	3600	213C/182TC 215C/184TC
215	6, 24, 90	95	3600	213TC/215TC

* For 56C/48Y Frame motors 3/4 HP and smaller the UM-100 size may be used where extended life is desirable.
 ** UM-100 size is recommended for motors 1 HP and larger.

For standard NEMA frame dimensions, see page 187.

Only 50, 100, and 180 sizes of the models listed will be converted to the new GEN 2 design.
 210 and 215 sizes will continue to be offered in the original design and will not be converted.

UM-1040 Motor Clutch/Output Clutch Combination

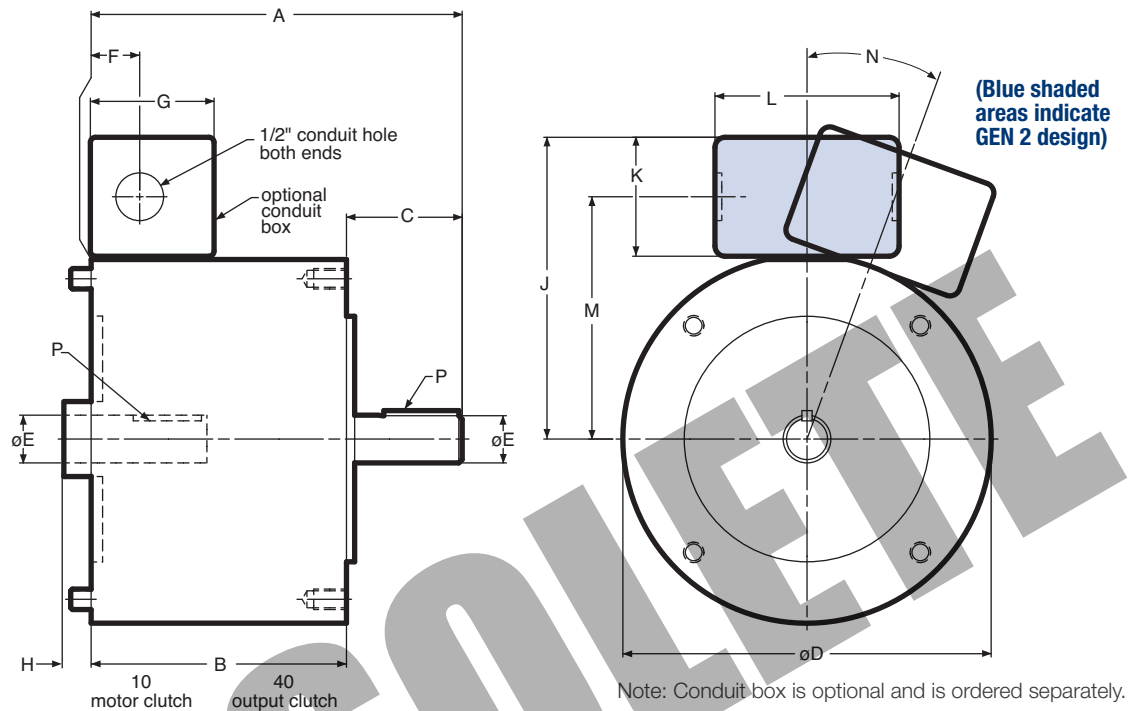

Dimensions (Blue shaded areas indicate GEN 2 design)

Size	A	B	C	D	E	F	G	H
50	6.720	4.680	2.040	6.750	.625	.890	2.267	—
100	6.741	4.680	2.061	6.750	.625	.890	2.267	—
180	6.801	4.680	2.121	6.750	.875	.890	2.267	—
210	8.891	5.922	2.500	9.250	1.125	.500	2.267	.500
215	9.391	5.922	3.000	9.250	1.375	.500	2.267	.500

Size	J	K	L	M	N	P
50	5.516	2.180	3.250	4.426	0°	3/16 x 3/16
100	5.516	2.180	3.250	4.426	0°	3/16 x 3/16
180	5.516	2.180	3.250	4.426	0°	3/16 x 3/16
210	6.859	2.180	3.250	5.766	20°	1/4 x 1/4
215	6.859	2.180	3.250	5.766	20°	5/16 x 5/16

Specifications (Blue shaded areas indicate GEN 2 design)

Model Size	Voltage DC	Static Torque lb. ft.	Max. RPM	NEMA Frame Size
50	6, 24, 90	16	3600	56C/48Y*
100	6, 24, 90	30	3600	56C/48Y**
180	6, 24, 90	30	3600	182C/143TC 184C/145TC
210	6, 24, 90	95	3600	213C/182TC 215C/184TC
215	6, 24, 90	95	3600	213TC/215TC

* For 56C/48Y Frame motors 3/4 HP and smaller the UM-100 size may be used where extended life is desirable.

** UM-100 size is recommended for motors 1 HP and larger.

For standard NEMA frame dimensions, see page 187.

Only 50, 100, and 180 sizes of the models listed will be converted to the new GEN 2 design. 210 and 215 sizes will continue to be offered in the original design and will not be converted.

UM Series UniModule

UM-2030 Input Clutch/Brake Combination

UM-2030-B Input Clutch/Brake Combination – Base Mounted

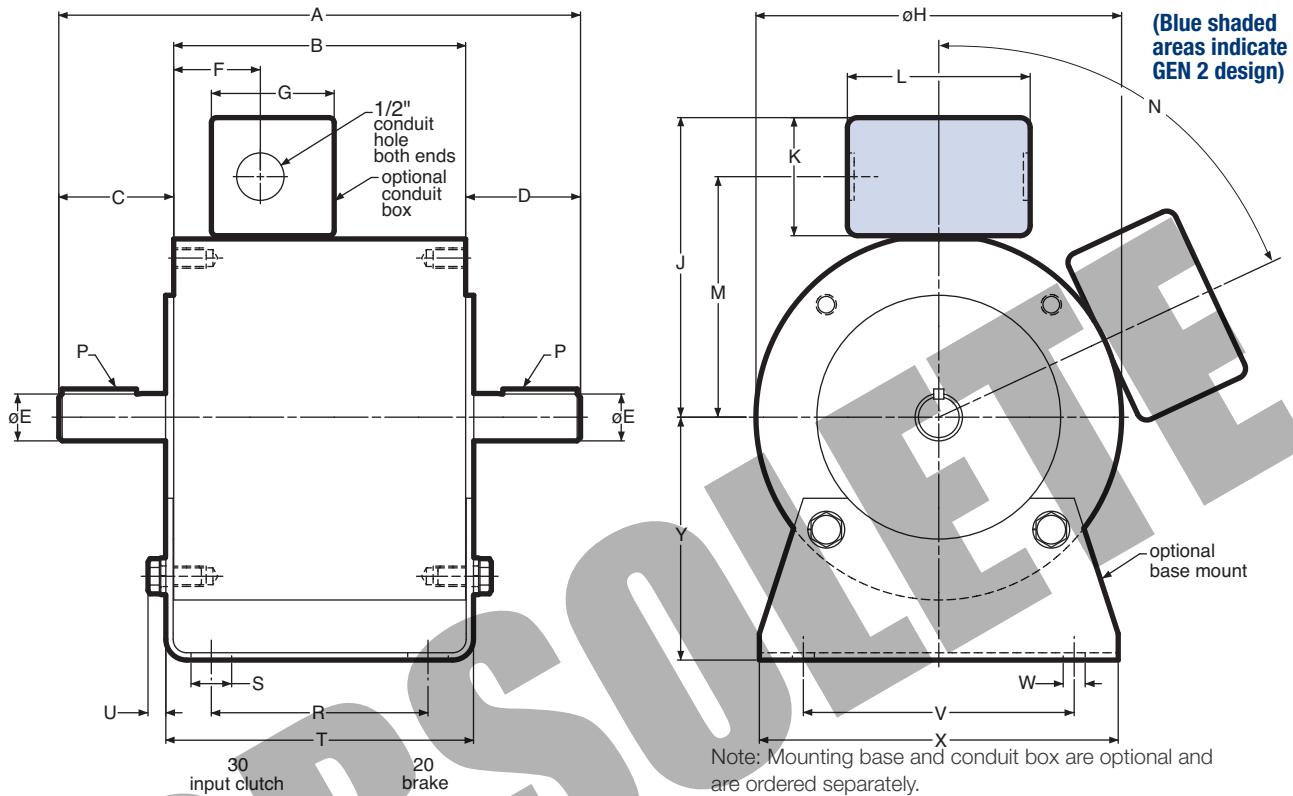

Dimensions (Blue shaded areas indicate GEN 2 design)

Size	A	B	C	D	E	F	G	H	J	K	L	M
50	9.492	5.390	2.062	2.040	.625	1.600	2.267	6.750	5.516	2.180	3.250	4.426
100	9.512	5.390	2.061	2.061	.625	1.600	2.267	6.750	5.516	2.180	3.250	4.426
180	9.632	5.390	2.121	2.121	.875	1.600	2.267	6.750	5.516	2.180	3.250	4.426
210	12.969	7.719	2.500	2.500	1.125	1.812	2.267	9.250	6.859	2.180	3.250	5.766
215	12.969	7.719	2.500	2.500	1.375	1.812	2.267	9.250	6.859	2.180	3.250	5.766

Size	N	P	R	S	T	U	V	W	X	Y
50	0°	3/16 x 3/16	4.000	.800	5.680	.329	5.000	.406	6.000	3.500
100	0°	3/16 x 3/16	4.000	.800	5.680	.329	5.000	.406	6.000	3.500
180	0°	3/16 x 3/16	4.000	.750	5.680	.329	5.000	.406	6.625	4.500
210	65°	1/4 x 1/4	6.000	.750	8.260	.437	7.750	.534	9.000	5.250
215	65°	5/16 x 5/16	6.000	.750	8.260	.437	7.750	.534	9.000	5.250

Specifications (Blue shaded areas indicate GEN 2 design)

Model Size	Voltage DC	Static Torque lb. ft.	Max. RPM
50	6, 24, 90	16	3600
100	6, 24, 90	30	3600
180	6, 24, 90	30	3600
210	6, 24, 90	95	3600
215	6, 24, 90	95	3600

For standard NEMA frame dimensions, see page 187.

Only 50, 100, and 180 sizes of the models listed will be converted to the new GEN 2 design. 210 and 215 sizes will continue to be offered in the original design and will not be converted.

UM-3040 Input Clutch/Output Clutch Combination UM-3040-B Input Clutch/Output Clutch Combination—Base Mounted

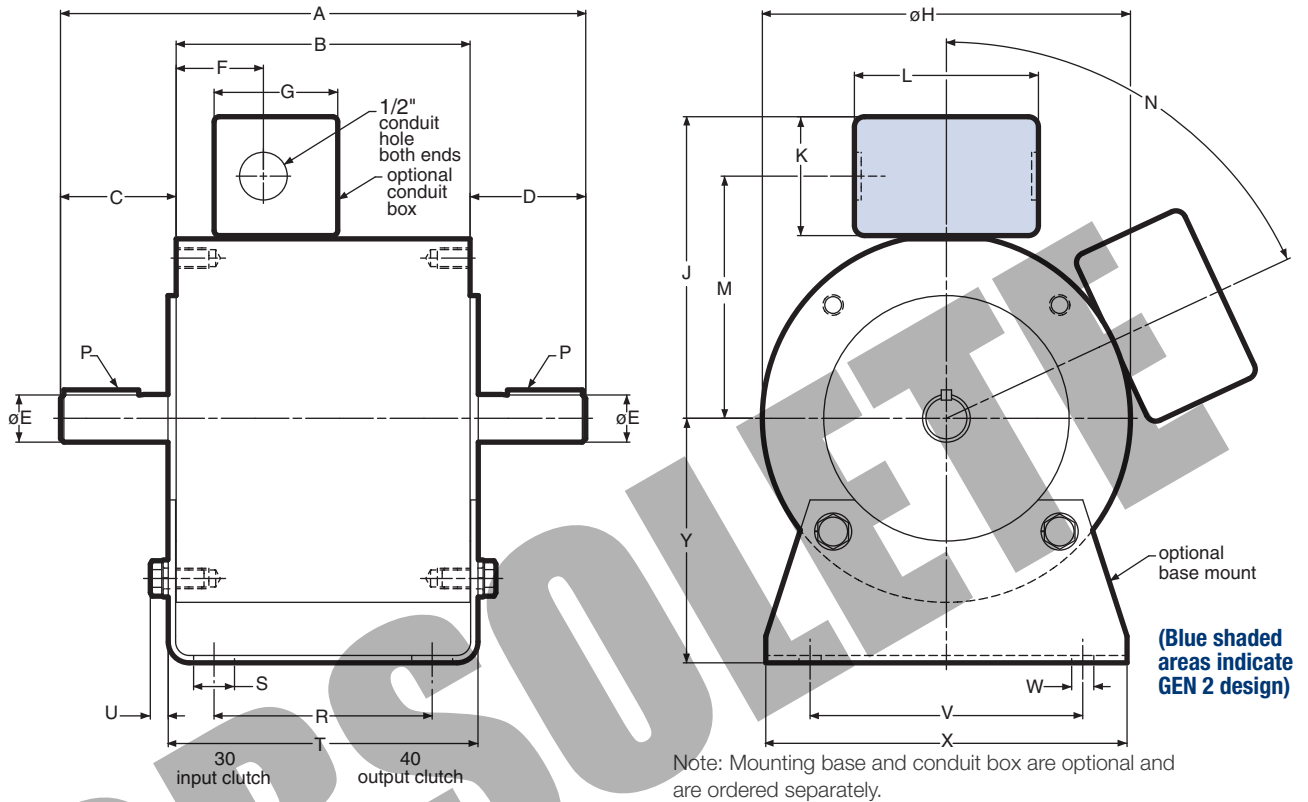

Dimensions (Blue shaded areas indicate GEN 2 design)

Size	A	B	C	D	E	F	G	H	J	K	L	M
50	9.492	5.390	2.062	2.040	.625	1.600	2.267	6.750	5.516	2.180	3.250	4.426
100	9.512	5.390	2.061	2.061	.625	1.600	2.267	6.750	5.516	2.180	3.250	4.426
180	9.632	5.390	2.121	2.121	.875	1.600	2.267	6.750	5.516	2.180	3.250	4.426
210	12.969	7.719	2.500	2.500	1.125	1.812	2.267	9.250	6.859	2.180	3.250	5.766
215	12.969	7.719	2.500	2.500	1.375	1.812	2.267	9.250	6.859	2.180	3.250	5.766

Size	N	P	R	S	T	U	V	W	X	Y
50	0°	3/16 x 3/16	4.000	.800	5.680	.329	5.000	.406	6.000	3.500
100	0°	3/16 x 3/16	4.000	.800	5.680	.329	5.000	.406	6.000	3.500
180	0°	3/16 x 3/16	4.000	.750	5.680	.329	5.000	.406	6.625	4.500
210	65°	1/4 x 1/4	6.000	.750	8.260	.437	7.750	.534	9.000	5.250
215	65°	5/16 x 5/16	6.000	.750	8.260	.437	7.750	.534	9.000	5.250

Specifications (Blue shaded areas indicate GEN 2 design)

Model Size	Voltage DC	Static Torque lb. ft.	Max. RPM
50	6, 24, 90	16	3600
100	6, 24, 90	30	3600
180	6, 24, 90	30	3600
210	6, 24, 90	95	3600
215	6, 24, 90	95	3600

For standard NEMA frame dimensions, see page 187.

Only 50, 100, and 180 sizes of the models listed will be converted to the new GEN 2 design. 210 and 215 sizes will continue to be offered in the original design and will not be converted.

EM Series Electro Module

Individual Clutch or Brake Module Combine to Comprise a Clutch, Brake or Clutch/Brake Combination

Electro Modules are individual clutch or brake units which are assembled together to comprise a clutch, brake, or clutch/brake combination. Electro Modules can be bolted directly to a NEMA C-face motor or reducer or they can be base mounted for stand alone operation. Electro Modules offer the ultimate in clutch/brake convenience. They are easy and quick to install and require no lubrication or maintenance for life.

Bolt-it-down and wire-it-up ... it's ready to go!

- Modular design flexibility
- 1/4 to 7-1/2 HP at 1800 RPM
- Outstanding controllability
- Fast cycling
- Smooth starts and stops
- Accurate
- Bidirectional
- Consistent performance
- Complete control capability

Selection Flexibility Clutch/Brake Combination

A wide range of module combinations for use with motors, reducers and other standard power transmission components is available. The flexibility of Electro Module enables you to pick the exact combination of function and design.

Power-On Applications

Electro Modules for power-on applications are purchased as individual clutches and brakes to be assembled for C-face, flange, or base mounting applications.

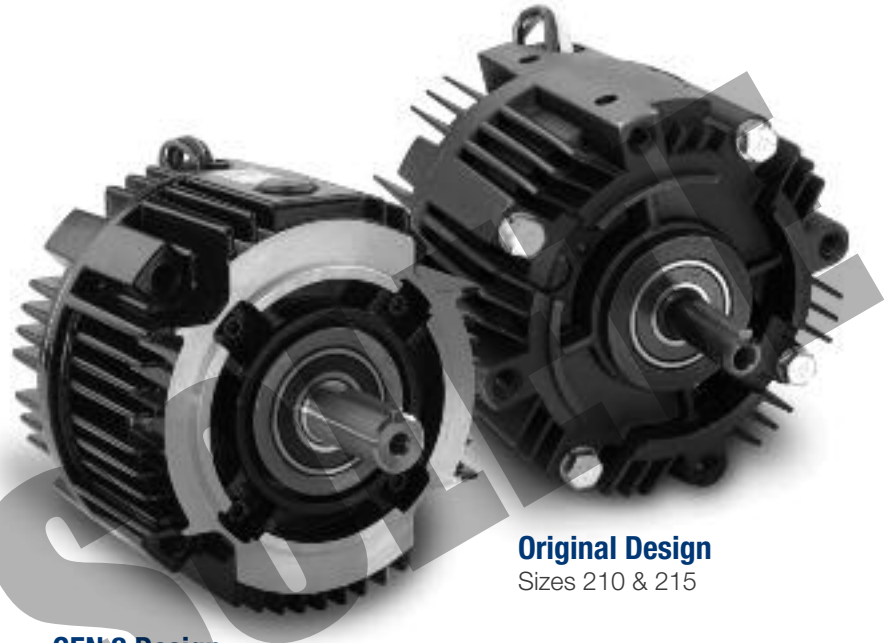

GEN 2 Design

Sizes 50, 100 & 180

Original Design

Sizes 210 & 215

Power-Off (Electrically Released) Applications

Electrically released operation is the primary feature of power-off Electro Module brakes. They can be used as brakes, motor brakes and in combination with clutches. See page 106 for complete information.

Selection

The correct size can be determined from easy-to-use selection charts based on NEMA frame sizes or horsepower and shaft speed. Examples show the right way to order the Electro Module required.

Controls

Warner Electric controls assure that you get the maximum performance from your Electro Module. See page 201.

Modular Components

Clutch Modules



10 Motor Clutch

Fan cooled for long life and consistent performance. See page 30.



30 Input Clutch

Fan cooled. Sealed coil. Twin bearing mounted shaft maintains tight concentricities. See page 33.



40 Output Clutch

Autogap™ automatically adjust armature for wear. Does not have a coil – use in combination with a 10 Motor Clutch or 30 Input Clutch module. See page 34.

Brake Modules



20 Brake

Bolts directly to C-face components. See page 31.



20MB Motor Brake

Does not have a shaft. Has end cap. See page 32.

Clutch Combinations



10/40 Motor Clutch/Output Clutch

Use for clutch only applications. Has hollow bore input for mounting directly to C-face motors. Shaft and C-face on output side of unit accommodates reducer, parallel drive or coupling. Basic components are field, rotor and armature. See page 36.

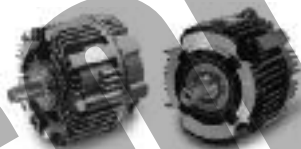

30/40 Input Clutch/Output Clutch

Use for clutch only applications. Features dual C-faces and shafts. Unit input from parallel drive or coupling. Output to reducer. Basic components are field, rotor and armature. See page 38.



30/40-B Input Clutch/Output Clutch-Base Mounted

Base mounting allows the clutch units to be utilized as a separate drive unit. Attach with pulleys, sprockets, etc. See page 38.

Clutch/Brake Combinations



10/20 Motor Clutch/Brake

Use for clutch/brake applications. Hollow bore input. Shaft on output side. Basic components are field, rotor, 2 armatures and power-on magnet. See page 35.



20/30 Brake/Input Clutch

Use for clutch/brake applications. Features dual C-faces and shafts. Input from parallel drive or coupling. Output to reducer. Basic components are field, rotor, 2 armatures and power-on magnet. See page 37.



20/30-B Brake/Input Clutch-Base Mounted

Stand alone units attach with pulleys, sprockets, etc. See page 37.

EM Series Electro Module

Selection

Electro Module clutch or brake units may be mounted directly to NEMA C-face motors and reducers, or can be base mounted.

1. Select Configuration

a. NEMA C-face Mounting

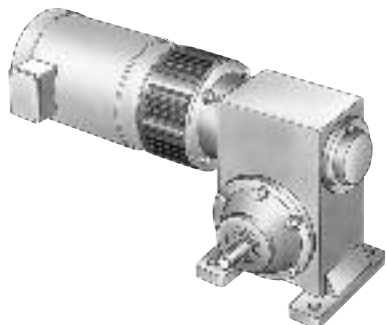

Based on the NEMA C-face frame size of the prime mover, select the correct clutch or brake module size from the Frame Size Selection chart. Size 100 houses the components of the size 180 in a size 50 frame, while size 215 incorporates size 210 components.

b. Base Mounting

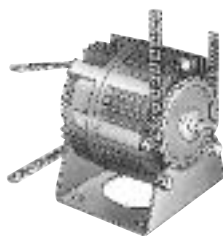

Electro Module assemblies may be mounted as separate drive units driven from the prime mover by V-belts, chain and sprockets, couplings, timing belts and other standard power transmission components.

Select the correct size module from the Horsepower vs. Shaft Speed chart by determining the motor horsepower and RPM at the module location. The correct size Electro Module is shown at the intersection of the HP and operating speed.

For additional sizing information, refer to the technical sizing procedure (step 2).

2. Determine Technical Requirements

Technical considerations for sizing and selection are torque and heat dissipation. Each merits careful consideration, especially heat dissipation as over time, use in excessive temperature environments will have an adverse effect on bearing life and coil wire insulation integrity.

Compare the calculated torque requirement with the average dynamic torque ratings. Select a unit with adequate torque. If the unit selected on torque is different than the unit selected based on heat, select the larger size unit.

Frame Size Selection

NEMA Frame Size	Electro Module Size
56C/48Y	EM-50* EM-100**
182C/143TC 184C/145TC	EM-180
213C/182TC	EM-210
215C/184TC	EM-215
213TC/215TC	EM-215

* For 56C/48Y Frame motors 3/4 HP and smaller the UM-100 size may be used where extended life is desirable.

** UM-100 size is recommended for motors 1 HP and larger.

Horsepower vs. Shaft Speed

HP	SHAFT SPEED AT CLUTCH (IN RPM)																		
	100	200	300	400	500	600	700	800	900	1000	1100	1200	1500	1800	2000	2400	3000	3600	
1/4																			
1/2														EM-50					
3/4																			
1																			
1-1/2														EM-100 or EM-180					
2																			
3																			
5																			
7-1/2																			

a. Heat Dissipation Sizing

Friction surfaces slip during the initial period of engagement and, as a result, heat is generated. The clutch/brake selected must have a heat dissipation rating greater than the heat generated by the application. Therefore, in high inertia or high cycle rate applications, it is necessary to check the heat dissipation carefully. Inertia, speed and cycle rate are the required parameters.

Heat dissipation requirement is calculated as follows:

$$E = 1.7 \times WR^2 \times (N/100)^2 \times F$$

where:

$$E = \text{Heat (lb. ft./min.)}$$

WR^2 = Total reflected inertia at the clutch/brake shaft. Include the clutch/brake output inertia. (lb.ft.²)

N = Speed in revolutions per minute (RPM)

F = Cycle rate in cycles per minute (CPM)

Compare the calculated heat generated in the application to the unit ratings using the heat dissipation curves. Select the appropriate unit that has adequate heat dissipation ability.

Heat Dissipation Curves

Size 50

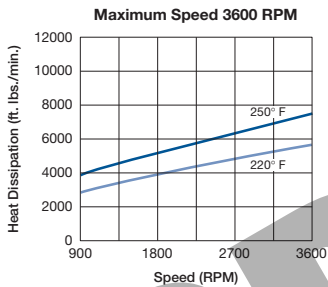

Size 100/180

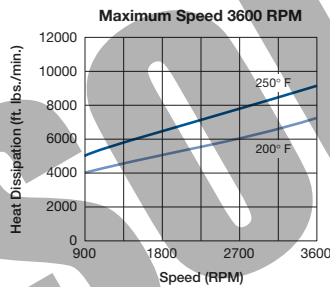

Size 210/215

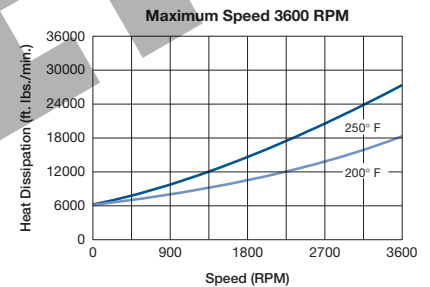

b. Torque Sizing

For most applications, the correct size clutch/brake can be selected from the Horsepower vs. Shaft Speed chart.

Determine the motor horsepower and the RPM at the clutch/brake. The correct size unit is shown at the intersection of horsepower and shaft speed.

If the static torque requirements are known, refer to the Specifications Table to select a unit.

For some applications, the torque requirement is determined by the time allowed to accelerate and decelerate the load. (This time is generally specified in milliseconds.) For these applications, it is necessary to determine the torque requirement based on load inertia and the time allowed for engagement.

The torque requirements are calculated as follows:

$$T = (WR^2 \times N) / (308 \times t)$$

where:

$$T = \text{Average Dynamic Torque (lb. ft.)}$$

WR^2 = Total reflected inertia at the clutch/brake shaft. Include the clutch/brake output inertia. (lb. ft.²)

N = Speed in revolutions per minute (RPM)

t = Time allowed for the engagement (sec)

C-face Clutch/Power-on Brake Dynamic Torque Curves

Size 50

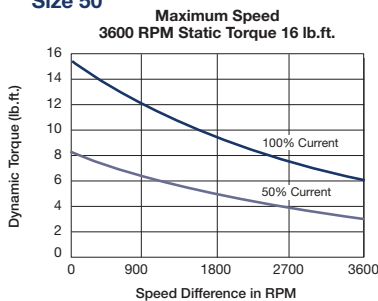

Size 100/180

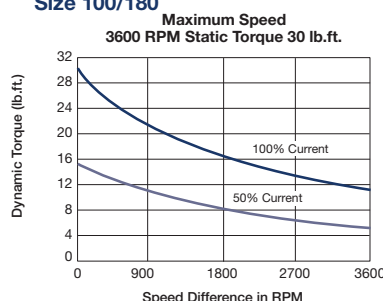

Size 210/215

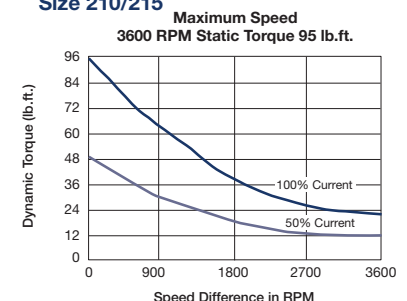

EM Series Electro Module

Specifications (Blue shaded areas indicate GEN 2 design)

EM Size	Static Torque lb. ft.	Maximum RPM	Voltage D.C.
50	16	3600	6, 24, or 90
100	30	3600	6, 24, or 90
180	30	3600	6, 24, or 90
210	95	3600	6, 24, or 90
215	95	3600	90

3. Accessories

Warner Electric Electro Modules can be fitted with several accessories to extend their capacity and ease of mounting.

a. Conduit Box

NEMA 4 and UL listed, available in standard and washdown versions.



b. Mounting Brackets

Two styles of mounting brackets are available for simplified installation. The base mount is used with the 20/30 and 30/40 configurations. A motor mount is also available and provides sturdy support for 20, 10/20 and 10/40 units and motor.

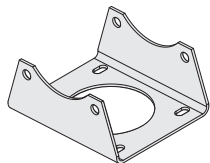

Base Mount

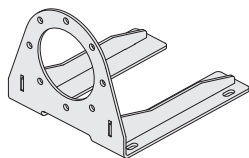

Motor Mount
For 50, 100 & 180 sizes

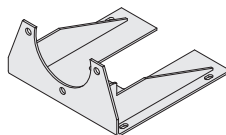

Motor Mount
For 210 & 215 sizes

c. Cover Kit – For sizes 50, 100 & 180



Each cover kit includes two (2) vent covers, two (2) gaskets and four (4) screws needed to convert a vented design into an enclosed design. For brake only modules, a cover plate is included to enclose the back of the brake.

4. Select Control

Warner Electric manufactures clutch/brake controls to meet several system functions including:

- On/Off
- Torque adjust
- Over excitation
- Position loop

Many requirements beyond function can impact control selection. See the Controls Section on page 201.

Ordering Information

Part Numbers

(Blue shaded areas indicate GEN 2 design)

Only 50, 100, and 180 sizes of the models listed will be converted to the new GEN 2 design. 210 and 215 sizes will continue to be offered in the original design and will not be converted.

Model No.	Voltage D.C.	GEN 2 Part No.	Original Part No.
10 Motor Clutch Module			
EM-50-10	6	5370-270-201	5370-270-020
EM-50-10	24	5370-270-203	5370-270-030
EM-50-10	90	5370-270-204	5370-270-015
EM-100-10	6	5370-270-206	5370-270-045
EM-100-10	24	5370-270-208	5370-270-056
EM-100-10	90	5370-270-209	5370-270-046
EM-180-10	6	5370-270-211	5370-270-021
EM-180-10	24	5370-270-213	5370-270-055
EM-180-10	90	5370-270-214	5370-270-017
EM-210-10	6		5371-270-011
EM-210-10	24		5371-270-027
EM-210-10	90		5371-270-009

Model No.	Voltage D.C.	GEN 2 Part No.	Original Part No.
20 Brake Module			
EM-50-20	6	5370-169-201	5370-169-043
EM-50-20	24	5370-169-203	5370-169-045
EM-50-20	90	5370-169-204	5370-169-042
EM-100-20	6	5370-169-206	5370-169-040
EM-100-20	24	5370-169-208	5370-169-072
EM-100-20	90	5370-169-209	5370-169-041
EM-180-20	6	5370-169-211	5370-169-050
EM-180-20	24	5370-169-213	5370-169-071
EM-180-20	90	5370-169-214	5370-169-051
EM-210-20	6		5371-169-022
EM-210-20	24		5371-169-034
EM-210-20	90		5371-169-023
EM-215-20	24		5371-169-102
EM-215-20	90		5371-169-076

Model No.	Voltage D.C.	GEN 2 Part No.	Original Part No.
20MB Motor Brake			
EM-50-20MB	6	5370-169-216	5370-169-047
EM-50-20MB	24	5370-169-218	5370-169-062
EM-50-20MB	90	5370-169-219	5370-169-048
EM-180-20MB	6	5370-169-221	5370-169-053
EM-180-20MB	24	5370-169-223	5370-169-073
EM-180-20MB	90	5370-169-224	5370-169-054
EM-210-20MB	6		5371-169-025
EM-210-20MB	24		5371-169-035
EM-210-20MB	90		5371-169-026

Model No.	Voltage D.C.	GEN 2 Part No.	Original Part No.
30 Input Clutch Module			
EM-50-30	6	5370-270-216	5370-270-019
EM-50-30	24	5370-270-218	5370-270-052
EM-50-30	90	5370-270-219	5370-270-016
EM-100-30	6	5370-270-221	5370-270-047
EM-100-30	24	5370-270-223	5370-270-054
EM-100-30	90	5370-270-224	5370-270-048
EM-180-30	6	5370-270-226	5370-270-049
EM-180-30	24	5370-270-228	5370-270-053
EM-180-30	90	5370-270-229	5370-270-050
EM-210-30	6		5371-270-023
EM-210-30	24		5371-270-026
EM-210-30	90		5371-270-024

Model No.	Voltage D.C.	GEN 2 Part No.	Original Part No.
40 Output Clutch Module			
EM-50-40		5370-536-200	5370-536-008
EM-100-40		5370-536-201	5370-536-007
EM-180-40		5370-536-202	5370-536-009
EM-210-40			5371-536-005

Accessories

Description	EM Size	Part No.
Conduit Box	All sizes	5370-101-042
Base Mount Kit for 2030, 3040	50/100	5370-101-004
	180	5370-101-002
	210/215	5371-101-001
Motor Mount Kit for 20, 1020, 1040	50/100	5370-101-078
	180	5370-101-079
	210/215	5371-101-012
Cover Kit	50/100/180	5370-101-076
	50/100/180 (20 or 20MB)	5370-101-082

How to Order

Motor or Reducer Mounted

Simply combine the size number with the configuration of the modular combination from page 25. Specify voltage. See chart for specific part numbers. Power-off brake Electro Modules are found on page 106. Order optional conduit box if desired.

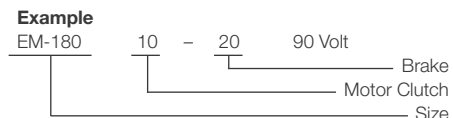

Base Mounted

Simply combine the size number with the configuration of the modular combination from page 25. Specify voltage. See chart for specific part numbers. Power-off brake Electro Modules are found on page 106. Order optional conduit box if desired.

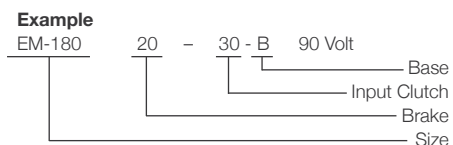

Select Appropriate Power Supply/Control. See the Controls Section beginning on page 201.

EM Series Electro Module

10 Motor Clutch Module

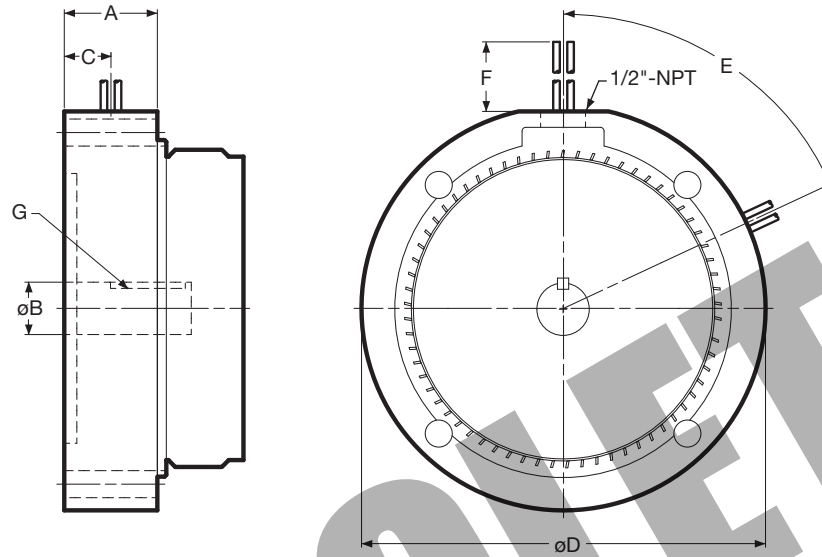

Dimensions (Blue shaded areas indicate GEN 2 design)

Size	A	B	C	D	E	F	G
50	1.555	.625	.780	6.750	0°	36	3/16 x 3/16
100	1.555	.625	.780	6.750	0°	36	3/16 x 3/16
180	1.555	.875	.780	6.750	0°	36	3/16 x 3/16
210	1.313	1.125	.700	9.250	65°	36	1/4 x 1/4

Specifications (Blue shaded areas indicate GEN 2 design)

Model Size	Voltage DC	Static Torque (lb. ft.)	Max. RPM	Inertia-WR ² (lb.ft. ²)	Weight (lbs)	NEMA Frame Size
50	6, 24, 90	16	3600	.020	6.4	56C/48Y*
100	6, 24, 90	30	3600	.046	7.6	56C/48Y**
180	6, 24, 90	30	3600	.046	7.6	182C/143TC 184C/145TC
210	6, 24, 90	95	3600	.188	9.1	213C/182TC 215C/184TC

* For 56C/48Y Frame motors 3/4 HP and smaller the UM-100 size may be used where extended life is desirable.

** UM-100 size is recommended for motors 1 HP and larger.

For standard NEMA frame dimensions, see page 187.

Only 50, 100, and 180 sizes of the models listed will be converted to the new GEN 2 design. 210 size will continue to be offered in the original design and will not be converted.

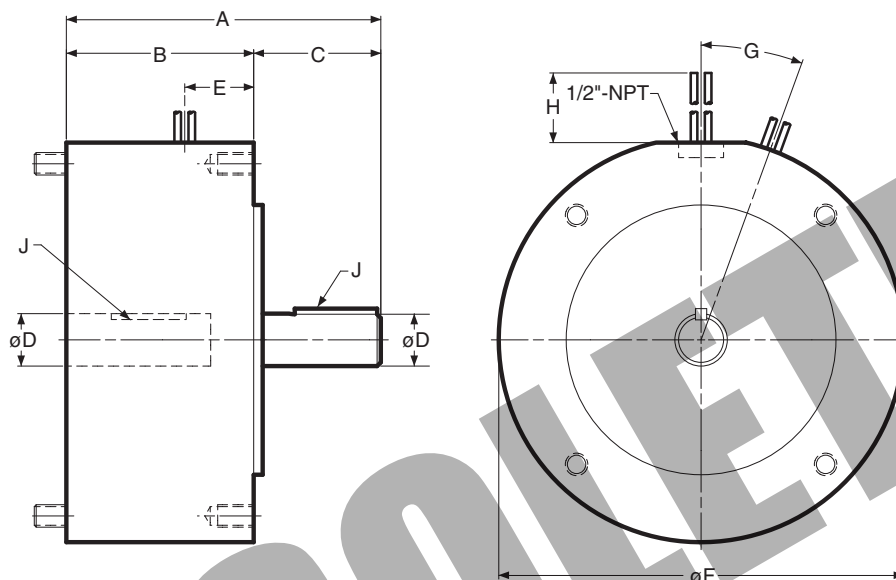

Dimensions (Blue shaded areas indicate GEN 2 design)

Size	A	B	C	D	E	F	G	H	J
50	5.165	3.125	2.040	.625	1.150	6.750	0°	36	3/16 x 3/16
100	5.186	3.125	2.061	.625	1.150	6.750	0°	36	3/16 x 3/16
180	5.246	3.125	2.121	.875	1.150	6.750	0°	36	3/16 x 3/16
210	7.578	4.609	2.500	1.125	1.812	9.250	20°	36	1/4 x 1/4
215	8.078	4.609	3.000	1.375	1.812	9.250	20°	36	5/16 x 5/16

Specifications (Blue shaded areas indicate GEN 2 design)

Model Size	Voltage DC	Static Torque (lb. ft.)	Max. RPM	Armatures (lb.ft. ²)	Inertia-WR ² Arm. Hub (lb.ft. ²)	Shaft (lb.ft. ²)	Weight (lbs)	NEMA Frame Size
50	6, 24, 90	16	3600	.014	.002	.001	9.2	56C/48Y*
100	6, 24, 90	30	3600	.036	.003	.002	11.2	56C/48Y**
180	6, 24, 90	30	3600	.036	.003	.002	11.2	182C/143TC 184C/145TC
210	6, 24, 90	95	3600	.162	.021	.017	21.5	213C/182TC 215C/184TC
215	24, 90	95	3600	.081(1)	.021	.022	22	213TC/215TC***

* For 56C/48Y Frame motors 3/4 HP and smaller the EM-100 size may be used where extended life is desirable.

** EM-100 size is recommended for motors 1 HP and larger.

*** For 7-1/2 HP max.

For standard NEMA frame dimensions, see page 187.

Only 50, 100, and 180 sizes of the models listed will be converted to the new GEN 2 design. 210 and 215 sizes will continue to be offered in the original design and will not be converted.

EM Series Electro Module

20MB Motor Brake Module

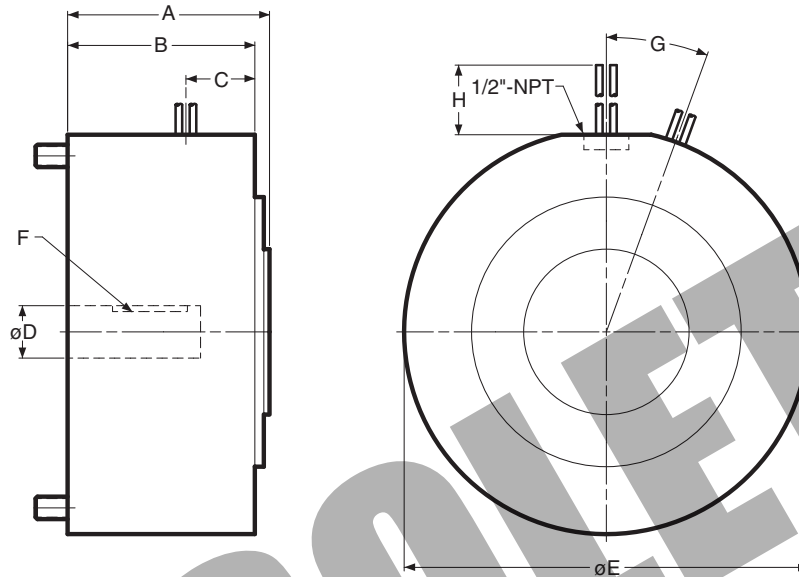

Dimensions (Blue shaded areas indicate GEN 2 design)

Size	A	B	C	D	E	F	G	H
50	3.368	3.125	1.150	.625	6.750	3/16 x 3/16	0°	36
180	3.368	3.125	1.150	.875	6.750	3/16 x 3/16	0°	36
210	5.150	4.610	1.812	1.125	9.250	1/4 x 1/4	20°	36

Specifications (Blue shaded areas indicate GEN 2 design)

Model Size	Voltage DC	Static Torque lb. ft.	Max. RPM	Armatures	Inertia-WR ² Arm. Hub	Input Hub	Weight (lbs)	NEMA Frame Size
50	6, 24, 90	16	3600	.014	.002	.001	9.2	56C/48Y*
180	6, 24, 90	30	3600	.036	.003	.002	11.2	182C/143TC 184C/145TC
210	6, 24, 90	95	3600	.162	.021	.017	21.5	213C/182TC 215C/184TC

*For 56C/48Y Frame motors 3/4 HP and smaller the EM-100 size may be used where extended life is desirable.

For standard NEMA frame dimensions, see page 187.

Only 50 and 180 sizes of the models listed will be converted to the new GEN 2 design.
210 size will continue to be offered in the original design and will not be converted.

EM Series Electro Module

30 Input Clutch Module

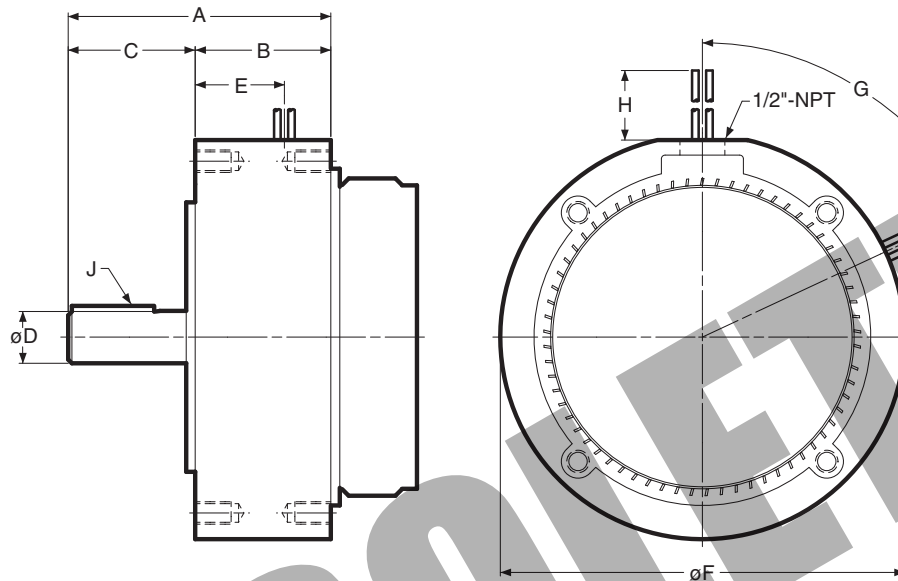

Dimensions (Blue shaded areas indicate GEN 2 design)

Size	A	B	C	D	E	F	G	H	J
50	4.327	2.265	2.040	.625	1.490	6.750	0°	36	3/16 x 3/16
100	4.326	2.265	2.061	.625	1.490	6.750	0°	36	3/16 x 3/16
180	4.386	2.265	2.121	.875	1.490	6.750	0°	36	3/16 x 3/16
210	5.391	2.438	2.500	1.125	1.812	9.250	65°	36	1/4 x 1/4

Specifications (Blue shaded areas indicate GEN 2 design)

Model Size	Voltage DC	Static Torque lb. ft.	Max. RPM	Inertia-WR ²		Weight (lbs)	NEMA Frame Size
				Rotor	Shaft		
50	6, 24, 90	16	3600	.020	.001	9.2	56C/48Y*
100	6, 24, 90	30	3600	.046	.002	10.5	56C/48Y**
180	6, 24, 90	30	3600	.046	.002	10.5	182C/143TC 184C/145TC
210	6, 24, 90	95	3600	.188	.017	19.8	213C/182TC 215C/184TC

* For 56C/48Y Frame motors 3/4 HP and smaller the EM-100 size may be used where extended life is desirable.

** EM-100 size is recommended for motors 1 HP and larger.

For standard NEMA frame dimensions, see page 187.

Only 50, 100, and 180 sizes of the models listed will be converted to the new GEN 2 design. 210 size will continue to be offered in the original design and will not be converted.

EM Series Electro Module

40 Output Clutch Module

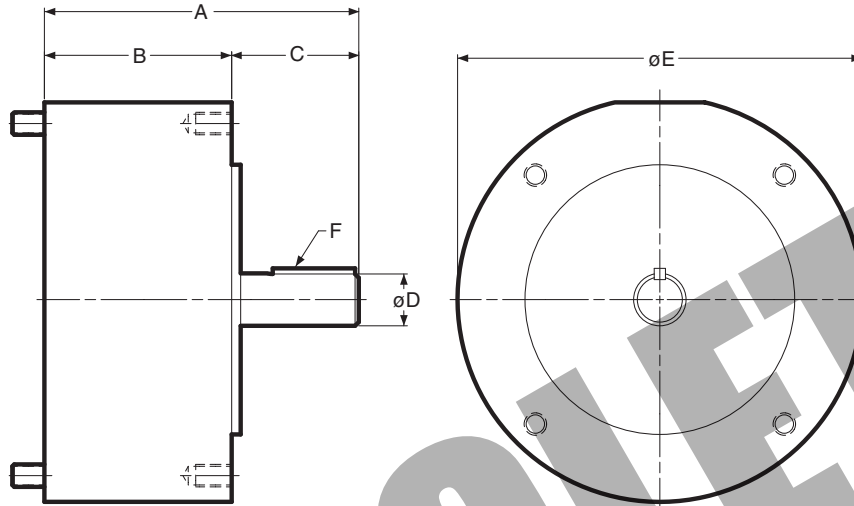

Dimensions (Blue shaded areas indicate GEN 2 design)

Size	A	B	C	D	E	F
50	5.165	3.125	2.040	.625	6.750	3/16 x 3/16
100	5.186	3.125	2.061	.625	6.750	3/16 x 3/16
180	5.246	3.125	2.121	.875	6.750	3/16 x 3/16
210	7.578	4.609	2.500	1.125	9.250	1/4 x 1/4

Specifications (Blue shaded areas indicate GEN 2 design)

Model Size	Voltage DC	Static Torque lb. ft.	Max. RPM	Armatures	Inertia-WR ² Arm. Hub	Shaft	Weight (lbs)	NEMA Frame Size
50	6, 24, 90	16	3600	.007	.002	.001	7.6	56C/48Y*
100	6, 24, 90	30	3600	.018	.003	.002	9.0	56C/48Y**
180	6, 24, 90	30	3600	.018	.003	.002	9.0	182C/143TC 184C/145TC
210	6, 24, 90	95	3600	.181	.021	.017	15.2	213C/182TC 215C/184TC

* For 56C/48Y Frame motors 3/4 HP and smaller the EM-100 size may be used where extended life is desirable.

** EM-100 size is recommended for motors 1 HP and larger.

For standard NEMA frame dimensions, see page 187.

Only 50, 100, and 180 sizes of the models listed will be converted to the new GEN 2 design. 210 size will continue to be offered in the original design and will not be converted.

EM Series Electro Module

EM-10/20 Motor Clutch/Brake Combination

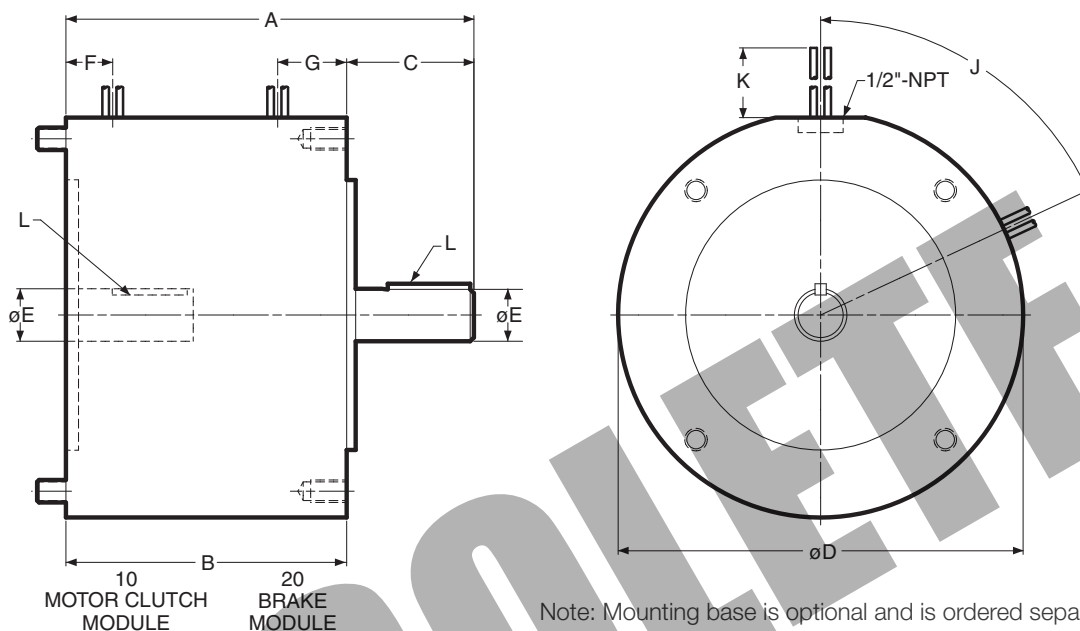

Note: Mounting base is optional and is ordered separately. Motor Clutch (10) and Brake (20) are ordered separately.

Dimensions (Blue shaded areas indicate GEN 2 design)

Size	A	B	C	D	E	F	G	J	K	L	NEMA Frame Size
50	6.720	4.680	2.040	6.750	.625	.780	1.150	0°	36	3/16 x 3/16	56C/48Y*
100	6.741	4.680	2.061	6.750	.625	.780	1.150	0°	36	3/16 x 3/16	56C/48Y**
180	6.801	4.680	2.121	6.750	.875	.780	1.150	0°	36	3/16 x 3/16	182C/143TC 184C/145TC
210	8.891	5.922	2.500	9.250	1.125	.700	1.812	65°	36	1/4 x 1/4	213C/182TC 215C/184TC

* For 56C/48Y Frame motors 3/4 HP and smaller the EM-100 size may be used where extended life is desirable.

** EM-100 size is recommended for motors 1 HP and larger.

For standard NEMA frame dimensions, see page 187.

Motor Mount (M) Dimensions (Blue shaded areas indicate GEN 2 design)

For use with 1020, 1040, 20, 20 FBB and 1020 FBC Combinations.

Size	R	S	T	U	V	W	Part No.
50/100	9.250	8.250	10.500	8.000	3.500	.800 x .406	5370-101-078
180	9.250	8.250	10.500	8.000	4.500	.800 x .406	5370-101-079
210/215	11.500	10.500	12.000	9.000	5.250	.750 x .409	5371-101-012

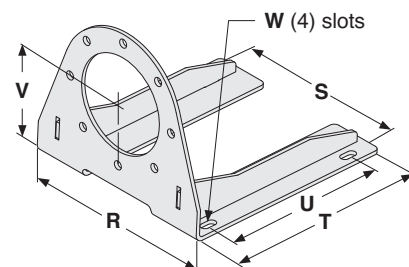

Only 50, 100, and 180 sizes of the models listed will be converted to the new GEN 2 design. 210 size will continue to be offered in the original design and will not be converted.

EM Series Electro Module

EM-10/40 Motor Clutch/Output Clutch Combination

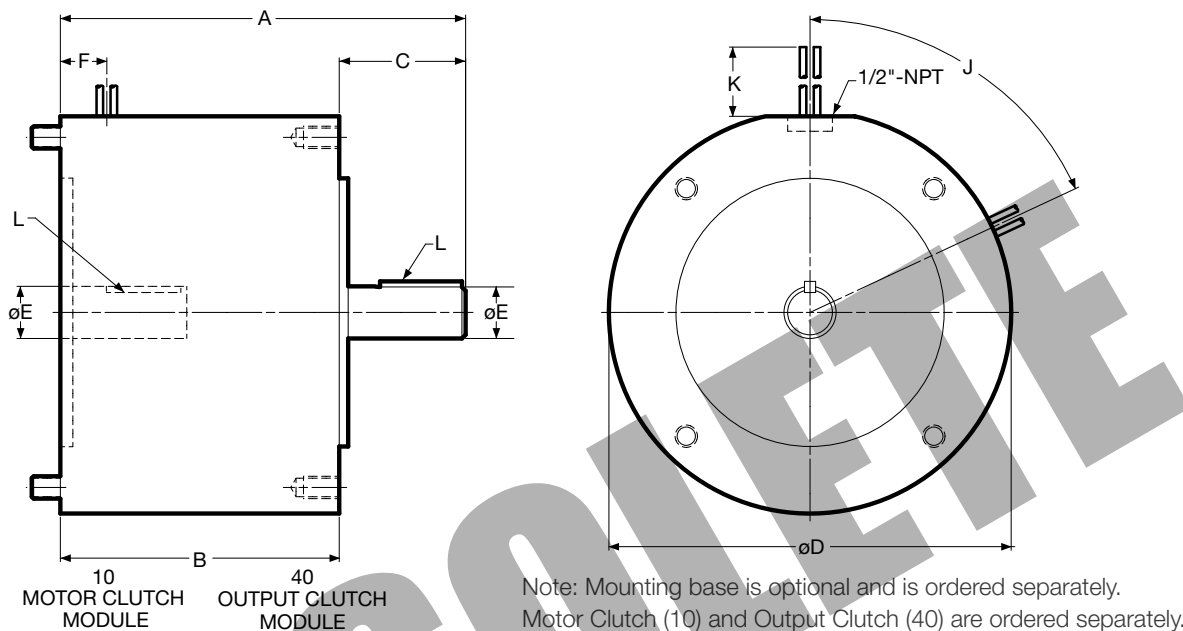

Dimensions (Blue shaded areas indicate GEN 2 design)

Size	A	B	C	D	E	F	G	J	K	L	NEMA Frame Size
50	6.720	4.680	2.040	6.750	.625	.780	1.150	0°	36	3/16 x 3/16	56C/48Y*
100	6.741	4.680	2.061	6.750	.625	.780	1.150	0°	36	3/16 x 3/16	56C/48Y**
180	6.801	4.680	2.121	6.750	.875	.780	1.150	0°	36	3/16 x 3/16	182C/143TC 184C/145TC
210	8.891	5.922	2.500	9.250	1.125	.700	1.812	65°	36	1/4 x 1/4	213C/182TC 215C/184TC

* For 56C/48Y Frame motors 3/4 HP and smaller the EM-100 size may be used where extended life is desirable.
 ** EM-100 size is recommended for motors 1 HP and larger.

For standard NEMA frame dimensions, see page 187.

Motor Mount (M) Dimensions (Blue shaded areas indicate GEN 2 design)

For use with 1020, 1040, 20, 20 FBB and 1020 FBC Combinations.

Size	R	S	T	U	V	W	Part No.
50/100	9.250	8.250	10.500	8.000	3.500	.800 x .406	5370-101-078
180	9.250	8.250	10.500	8.000	4.500	.800 x .406	5370-101-079
210/215	11.500	10.500	12.000	9.000	5.250	.750 x .409	5371-101-012

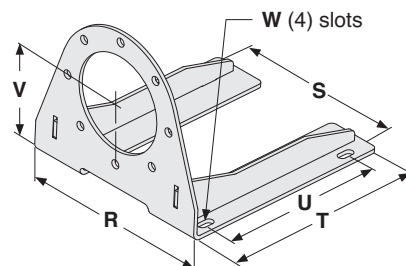

Only 50, 100, and 180 sizes of the models listed will be converted to the new GEN 2 design. 210 size will continue to be offered in the original design and will not be converted.

EM-20/30 Brake/Input Clutch Combination EM-20/30-B Brake/Input Clutch Combination – Base Mounted

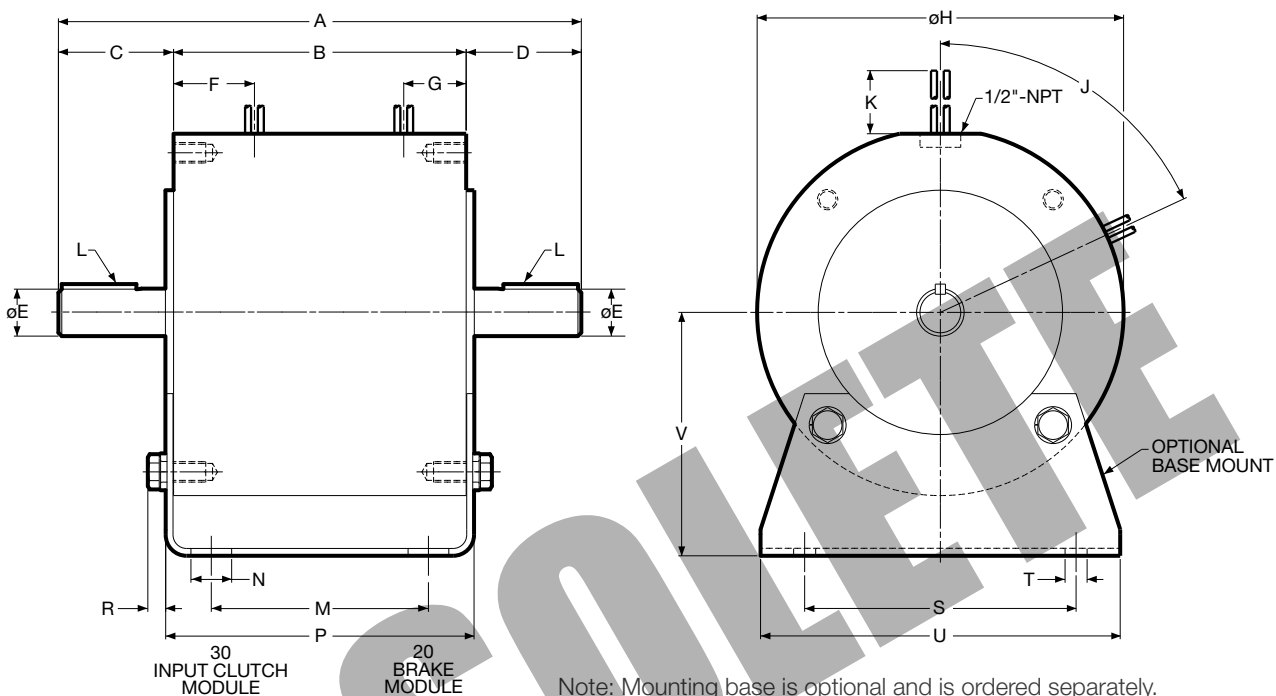

Note: Mounting base is optional and is ordered separately.
Input Clutch (30) module and Brake Module (20) are ordered separately.

Dimensions (Blue shaded areas indicate GEN 2 design)

Size	A	B	C	D	E	F	G	H	J	K	L
50	9.492	5.390	2.062	2.040	.625	1.490	1.150	6.750	0°	36	3/16 x 3/16
100	9.512	5.390	2.061	2.061	.625	1.490	1.150	6.750	0°	36	3/16 x 3/16
180	9.632	5.390	2.121	2.121	.875	1.490	1.150	6.750	0°	36	3/16 x 3/16
210	12.969	7.719	2.500	2.500	1.125	1.812	1.812	9.250	65°	36	1/4 x 1/4

Size	M	N	P	R	S	T	U	V
50	4.000	.800	5.680	.329	5.000	.406	6.000	3.500
100	4.000	.800	5.680	.329	5.000	.406	6.000	3.500
180	4.000	.750	5.680	.329	5.000	.406	6.625	4.500
210	6.000	.750	8.260	.437	7.750	.534	9.000	5.250

For standard NEMA frame dimensions, see page 187.

Only 50, 100, and 180 sizes of the models listed will be converted to the new GEN 2 design.
210 size will continue to be offered in the original design and will not be converted.

EM Series Electro Module

EM-30/40 Input Clutch/Output Clutch Combination

EM-30/40-B Input Clutch/Output Clutch Combination – Base Mounted

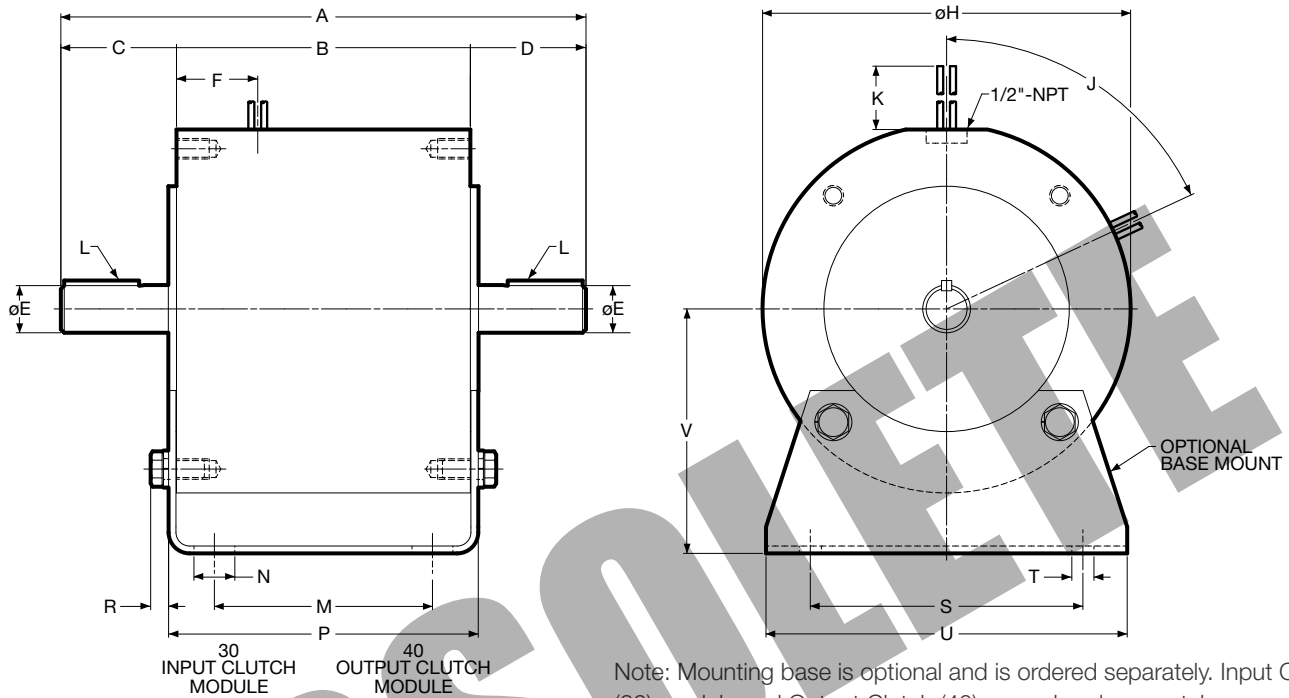

Dimensions (Blue shaded areas indicate GEN 2 design)

Size	A	B	C	D	E	F	G	H	J	K	L
50	9.492	5.390	2.062	2.040	.625	1.490	1.150	6.750	0°	36	3/16 x 3/16
100	9.512	5.390	2.061	2.061	.625	1.490	1.150	6.750	0°	36	3/16 x 3/16
180	9.632	5.390	2.121	2.121	.875	1.490	1.150	6.750	0°	36	3/16 x 3/16
210	12.969	7.719	2.500	2.500	1.125	1.812	1.812	9.250	65°	36	1/4 x 1/4

Size	M	N	P	R	S	T	U	V
50	4.000	.800	5.680	.329	5.000	.406	6.000	3.500
100	4.000	.800	5.680	.329	5.000	.406	6.000	3.500
180	4.000	.750	5.680	.329	5.000	.406	6.625	4.500
210	6.000	.750	8.260	.437	7.750	.534	9.000	5.250

For standard NEMA frame dimensions, see page 187.

Only 50, 100, and 180 sizes of the models listed will be converted to the new GEN 2 design. 210 size will continue to be offered in the original design and will not be converted.

Clean, quiet, operation. Nothing can get in, nothing can get out. Enclosed design eliminates damage to the working components. Prevents friction wear particles from escaping.

Totally Enclosed Version

The Enclosed Electro Module packages the hardworking components from EM products into a totally enclosed housing. This rugged housing keeps wear particles in and contaminants out and provides quiet operation. When enclosed, units are suitable for most industrial applications and tolerate infrequent, light washing.

- Keeps contaminants out
- Keeps wear particles in
- Quiet operation
- Finned for heat dissipation
- UL listed when optional conduit box is installed

To convert any Gen 2 Electro Module 50, 100, and 180 sizes to an enclosed model purchase optional Cover Kit

(part number 5370-101-076)

(part number 5370-101-082 for brake only)

Enclosed Electro Module (10-20, 10-40, 20-30, 30-40)

An optional cover kit (part number 5370-101-076) can be purchased separately to enclose the open vents in the housing. Each cover kit includes two vent covers, two gaskets and four screws needed to convert a vented Electro Module to an enclosed design (non-washdown).

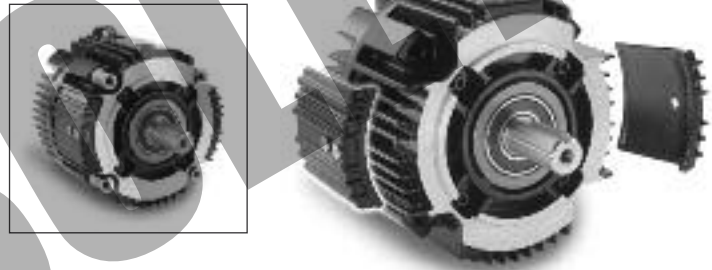

EUM-50

Maximum Speed 3600 RPM

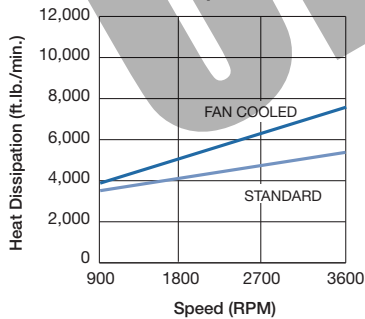

EUM-100/180

Maximum Speed 3600 RPM

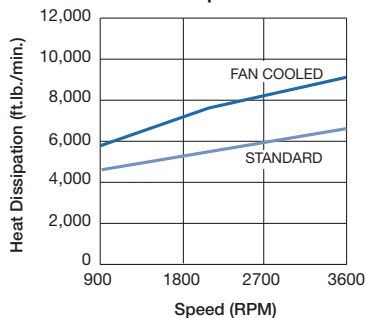

Enclosed Electro Module-Brake Only (20 or 20MB)

An optional cover kit (part number 5370-101-082) can be purchased separately to enclose the open vents in the housing and a cover plate to close off the back of the module. Each cover kit includes two vent covers, two gaskets, four screws and one cover plate needed to convert a vented Electro Module 20 to an enclosed design (non-washdown).



NOTE:

Enclosed option is not available for existing 210 & 215 size Electro Modules (EM)

UM Series Smooth-Start UniModules

Warner Electric Smooth-Start™ UniModules are designed for applications that require a softer than standard engagement. Through the use of LK friction material, the Smooth-Start design provides reduced torque to provide a less aggressive engagement, without suffering a loss of overall life due to the longer slip times.

When used with an adjustable power supply such as the CBC 300 or CBC 500/550, the Smooth-Start designs can provide a soft engagement that can be adjusted to meet specific application needs.



Smooth-Start™ UniModules

Warner Electric's new Smooth-Start UniModules are offered in 90 volt configurations as listed below. If you require another voltage, size or mounting configuration, please contact Warner Electric for assistance.

UniModule Size	NEMA Frame	Max. RPM	Static Torque (lb-ft)	Voltage (DC)	Original Part Number	GEN2 Part Number
50	56C/48Y	3600	10	90	5370-273-157	5370-273-236
100	56C/48Y	3600	18	90	5370-273-237	5370-273-237
180	182C/143TC 184C/145TC	3600	18	90	5370-273-158	5370-273-238
210	213C/182TC 215C/184TC	3600	57	90	5371-273-103	
215	213TC/215TC	3600	57	90	5371-273-080	

CBC-300 Dual Channel Torque Adjust Clutch/Brake Control

Conveyor applications occasionally require more clutch torque to start the line, and less brake torque to stop the line. With two independently adjustable channels, Warner Electric's CBC-300 allows you to set the torque levels for the clutch and brake independently of each other, so each can be tailored to every application to achieve optimum system performance.

Part Number	6021-448-001
Input Power	120 VAC +10% -15%, 50/60 Hz, single phase, 215 VA max.
Output	Pulse-width modulated full wave rectified D.C. Constant current, switch selectable ranges, 0-90 volt.
Current Adjust	Dual adjustable channels. Adjust via front panel potentiometers.
Other Features	UL listed; short circuit protection, line to line; torque limiting protects machine components from damage.

UM Series Smooth-Start UniModules

UM-1020 Motor Clutch/Brake Combination

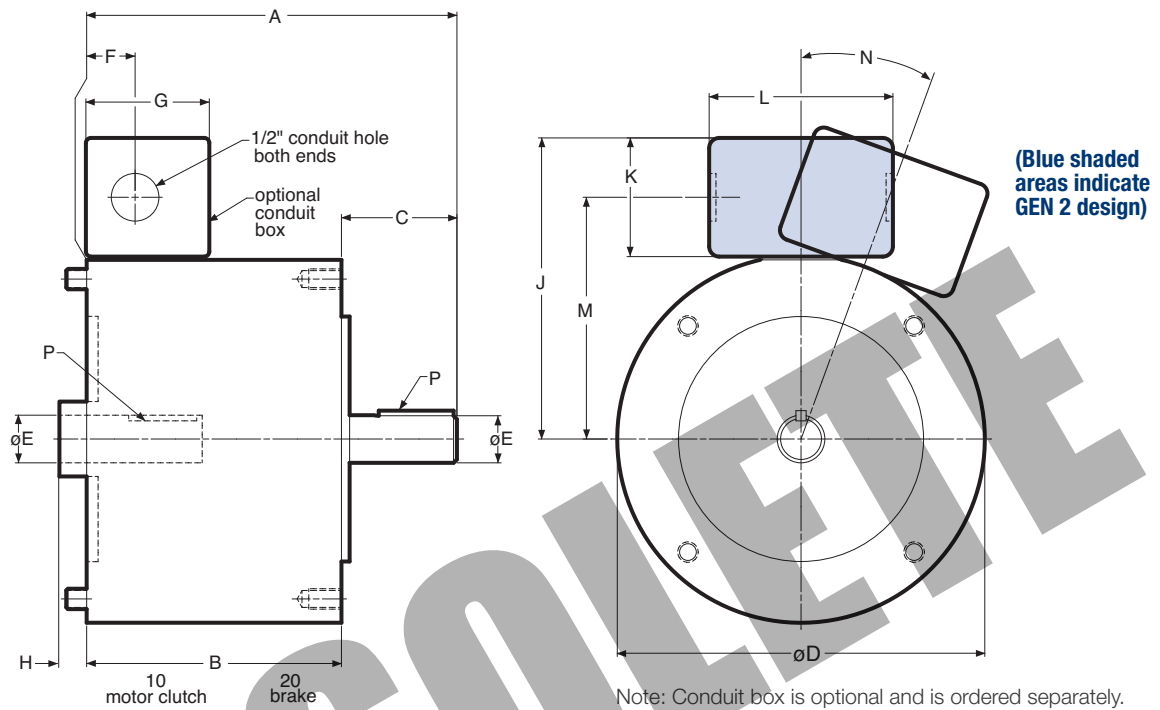

Dimensions (Blue shaded areas indicate GEN 2 design)

Size	A	B	C	D	E	F	G	H
50	6.720	4.680	2.040	6.750	.625	.890	2.267	—
100	6.741	4.680	2.061	6.750	.625	.890	2.267	—
180	6.801	4.680	2.121	6.750	.875	.890	2.267	—
210	8.891	5.922	2.500	9.250	1.125	.500	2.267	.500
215	9.391	5.922	3.000	9.250	1.375	.500	2.267	.500

Size	J	K	L	M	N	P
50	5.516	2.180	3.250	4.426	0°	3/16 x 3/16
100	5.516	2.180	3.250	4.426	0°	3/16 x 3/16
180	5.516	2.180	3.250	4.426	0°	3/16 x 3/16
210	6.859	2.180	3.250	5.766	20°	1/4 x 1/4
215	6.859	2.180	3.250	5.766	20°	5/16 x 5/16

Specifications (Blue shaded areas indicate GEN 2 design)

Model Size	Voltage DC	Static Torque lb. ft.	Max. RPM	NEMA Frame Size
50	90	10	3600	56C/48Y*
100	90	18	3600	56C/48Y*
180	90	18	3600	182C/143TC 184C/145TC
210	90	57	3600	213C/182TC 215C/184TC
215	90	57	3600	213TC/215TC

* For 56C/48Y Frame motors 3/4 HP and smaller the UM-100 size may be used where extended life is desirable.

** UM-100 size is recommended for motors 1 HP and larger.

For standard NEMA frame dimensions, see page 187.

Only 50, 100, and 180 sizes of the models listed will be converted to the new GEN 2 design. 210 and 215 sizes will continue to be offered in the original design and will not be converted.

UM-C Series UniModule – Ceramic Faced

High Performance with Extended Life

UniModules with ceramic friction material are pre-burnished during manufacturing to provide rated torque performance upon start up. They have been designed to mate easily with industry standard motors, reducers and other power transmission components.

- Bolt-it-down, wire-it-up... it's ready to go
- Available in 3 sizes; 50, 180 and 210 and 2 configurations; 1020 and 2030
- Standard voltages available 6V, 24V and 90V DC
- C-face or foot mounted
- No maintenance required
- Accurate positioning when used with CBC-700 OEX control

The Ceramic Difference . . .

Extended Life for High Cycle Rate Use

Ceramic faced clutches and brakes have been designed specifically for rapid cycling applications to satisfy today's needs for high speed equipment. Ceramic friction material provides excellent wear resistance that extends life 3 to 5 times that of standard clutch/brakes in demanding applications.

Consistent Torque and Cycle Repeatability

Preloaded armatures keep the ceramic friction surfaces lightly in contact to provide consistent torque and cycle-to-cycle repeatability. Variation is reduced by up to 30% over standard units. Autogap™ is not required.

Controllability – Smooth Start/Stop

With the ceramic friction surfaces always in contact, dynamic torque response is fast and precise. When used with a CBC-700 over-excitation control and CBC-1000 programmable counter, exceptional closed loop clutch/brake performance can be achieved approaching that of more expensive motion control technologies–The PerformancePlus difference!



UM-C Product Life

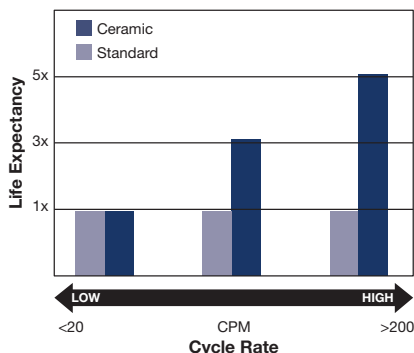

UM-C Cycle Repeat

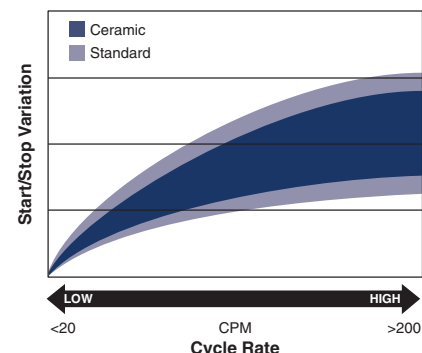

Ceramic UniModule clutch/brake units may be mounted directly to NEMA C-face motors and reducers, or can be base mounted.

1. Determine Mounting Configuration

a. NEMA C-face Mounting (1020 Configuration)

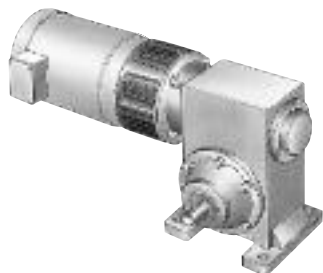

To select the correct Ceramic UniModule package, determine the NEMA frame size of your motor and/or reducer, and choose the corresponding size UniModule from the Frame Size Selection chart.

b. Base Mount (2030 Configuration)

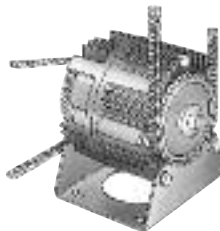

Ceramic UniModule assemblies may be mounted as separate drive units driven from the prime mover by V-belts, chain and sprockets, couplings, timing belts and other standard power transmission components.

Select the correct size module from the Horsepower vs. Shaft Speed chart by determining the motor horsepower and RPM at the module location. The correct size UniModule is shown at the intersection of the HP and operating speed. For additional sizing information, refer to the technical sizing procedure (step 2).

2. Determine Technical Requirements

Technical considerations for sizing and selection are torque and heat dissipation. Each merits careful consideration, especially heat dissipation as over time, use in excessive temperature environments will have an adverse effect on bearing life and coil wire insulation integrity.

Compare the calculated torque requirement with the average dynamic torque ratings. Select a unit with adequate torque. If the unit selected on torque is different than the unit selected based on heat, select the larger size unit.

Frame Size Selection

NEMA Frame Size	UniModule Size
56C/48Y	UM-50-C
182C/143TC 184C/145TC	UM-180-C
213C/182TC 215C/184TC	UM-210-C

Horsepower vs. Shaft Speed

HP	SHAFT SPEED AT CLUTCH (IN RPM)																		
	100	200	300	400	500	600	700	800	900	1000	1100	1200	1500	1800	2000	2400	3000	3600	
1/4																			
1/2																			
3/4																			
1																			
1-1/2																			
2																			
3																			
5																			
7-1/2																			
10																			

UM-C Series UniModule – Ceramic Faced

a. Heat Dissipation Sizing

Friction surfaces slip during the initial period of engagement and, as a result, heat is generated. The clutch/brake selected must have a heat dissipation rating greater than the heat generated by the application. Therefore, in high inertia or high cycle rate applications, it is necessary to check the heat dissipation carefully. Inertia, speed and cycle rate are the required parameters.

Heat dissipation requirement is calculated as follows:

$$E = 1.7 \times WR^2 \times (N/100)^2 \times F$$

where:

$$E = \text{Heat (lb. ft./min.)}$$

WR^2 = Total reflected inertia at the clutch/brake shaft. Include the clutch/brake output inertia. (lb.ft.²)

N = Speed in revolutions per minute (RPM)

F = Cycle rate in cycles per minute (CPM)

Compare the calculated heat generated in the application to the unit ratings using the heat dissipation curves. Select the appropriate unit that has adequate heat dissipation ability.

Note: At low cycle rates, the ceramic designs provide no additional wear life than standard designs.

Heat Dissipation Curves

UM-50-C

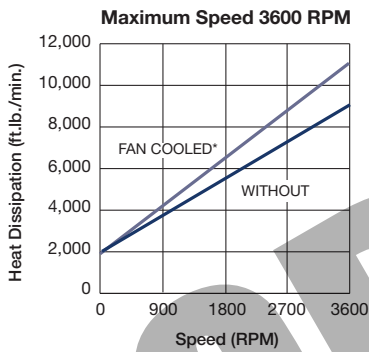

UM-180-C

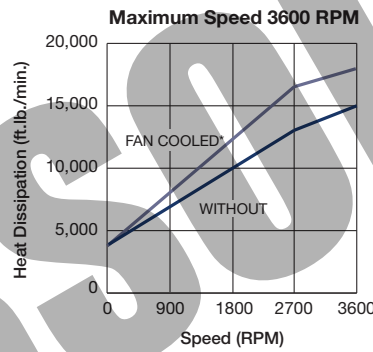

UM-210-C

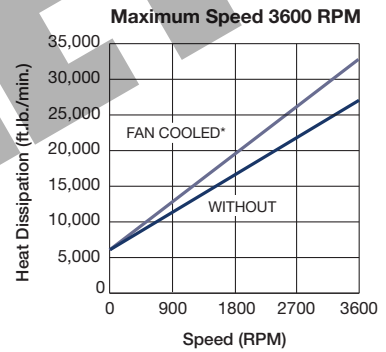

* Fan accessory kit available for 1020 configuration

b. Torque Sizing

For most applications, the correct size clutch/brake can be selected from the Horsepower vs. Shaft Speed chart.

Determine the motor horsepower and the RPM at the clutch/brake. The correct size unit is shown at the intersection of horsepower and shaft speed.

If the static torque requirements are known, refer to the Specifications Table to select a unit.

For some applications, the torque requirement is determined by the time allowed to accelerate and decelerate the load. (This time is generally specified in milliseconds.) For these applications, it is necessary to determine the torque requirement based on load inertia and the time allowed for engagement.

The torque requirements are calculated as follows:

$$T = (WR^2 \times N) / (308 \times t)$$

where:

$$T = \text{Average Dynamic Torque (lb. ft.)}$$

WR^2 = Total reflected inertia at the clutch/brake shaft. Include the clutch/brake output inertia. (lb. ft.²)

N = Speed in revolutions per minute (RPM)

t = Time allowed for the engagement (sec)

C-face Clutch/Power-on Brake Dynamic Torque Curves

Size 50

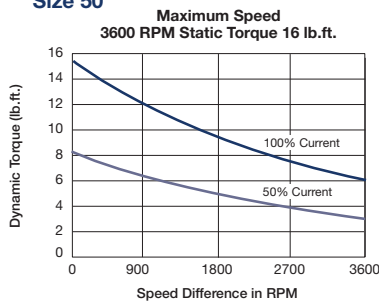

Size 180

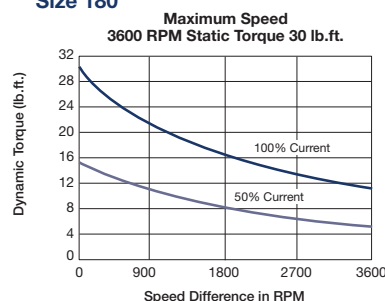

Size 210

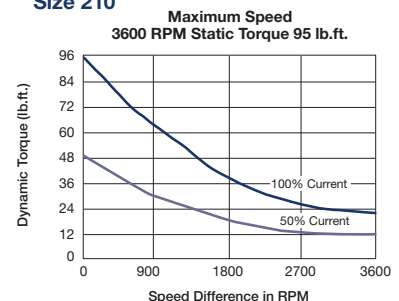

UM-C Series UniModule – Ceramic Faced

Selection/Ordering Information

Specifications (Blue shaded areas indicate GEN 2 design)

UniModule Size	Shaft Dia.	Static Torque lb. ft.	Horsepower	Max. RPM	Voltage DC	NEMA Frame Size
UM50-C	5/8"	16	1/4-3/4	3600	6, 24 and 90	56C/48Y
UM180-C	7/8"	30	1-2	3600	6, 24 and 90	182C/143TC 184C/145TC
UM210-C	1-1/8"	95	3-5	3600	6, 24 and 90	213/182TC 215C/184TC

3. Select Accessories

Warner Electric UniModules can be fitted with several accessories to extend their capacity and ease of mounting.

a. Conduit Box

NEMA 4 and UL listed.

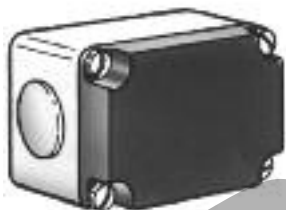

b. Mounting Brackets

Two styles of mounting brackets are available for simplified installation. The base mount is used with the 2030 configuration. A motor mount is also available and provides sturdy support for the 1020 and a motor.

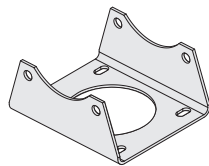

Base Mount

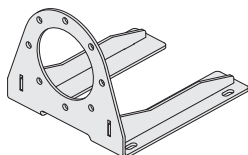

Motor Mount
For 50 & 180 sizes

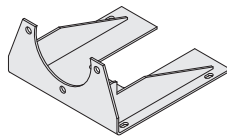

Motor Mount
For 210 size

c. Fan Kit (1020 only)

Extends the thermal capacity of any size UM. Mounts between motor and UM, includes shaft fan, guard and hardware.



4. Select Control

Warner Electric manufactures clutch/brake controls to meet several system functions including:

- On/Off
- Torque adjust
- Overexcitation
- Position loop

Many requirements beyond function can impact control selection. See the Controls Section on page 201 for complete information.

UM-C Series UniModule – Ceramic Faced

UM-1020-C Motor Clutch/Brake Combination

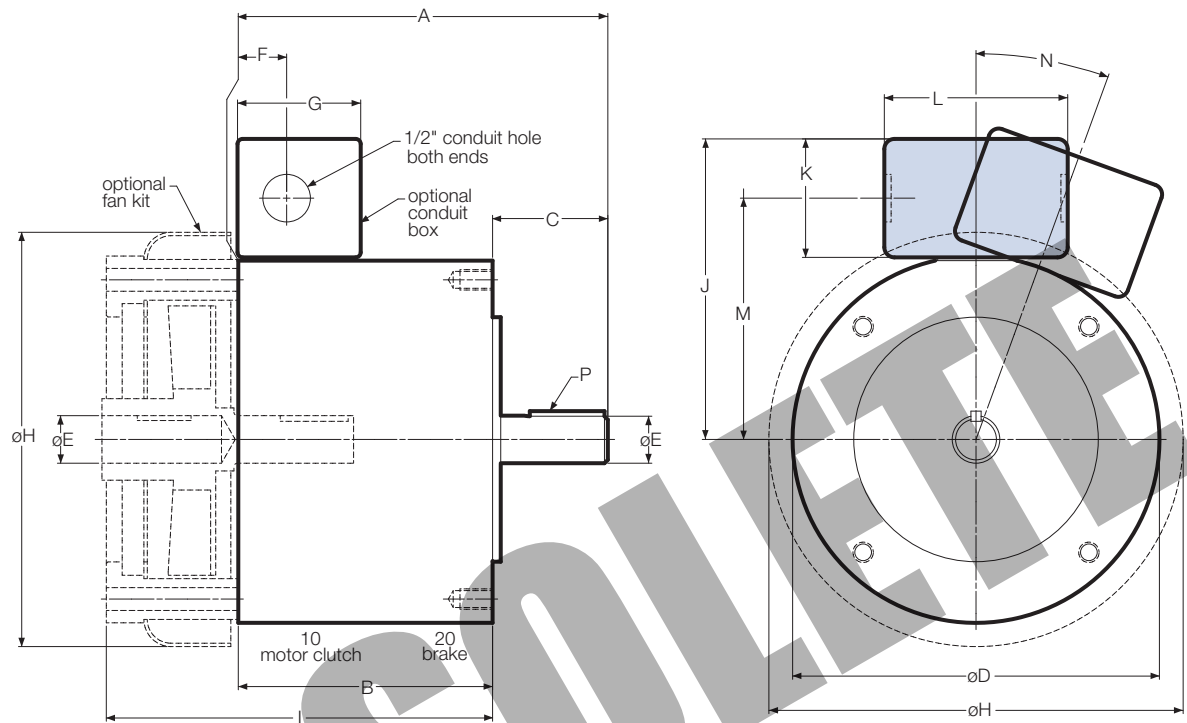

Dimensions (Blue shaded areas indicate GEN 2 design)

Size	A	B	C	D	E	F	G	H
50	6.720	4.680	2.040	6.750	.625	.890	2.267	7.620
180	6.801	4.680	2.121	6.750	.875	.890	2.267	7.620
210	9.391*	6.422*	2.500	9.250	1.125	.500	2.267	10.187

Size	I	J	K	L	M	N	P
50	7.110	5.516	2.180	3.250	4.426	0°	3/16 x 3/16
180	7.110	5.516	2.180	3.250	4.426	0°	3/16 x 3/16
210	9.297	6.859	2.180	3.250	5.766	20°	1/4 x 1/4

*Dimension includes the .500 thick adapter. Required for C-face mounting to a motor.

Specifications (Blue shaded areas indicate GEN 2 design)

UniModule Size	Static Torque lb. ft.	Horsepower	Max. RPM	Voltage DC	NEMA Frame Size
UM50-C	16	1/4-3/4	3600	6, 24 and 90	56C/48Y
UM180-C	30	1-2	3600	6, 24 and 90	182C/143TC 184C/145TC
UM210-C	95	3-5	3600	6, 24 and 90	213/182TC 215C/184TC

For standard NEMA frame dimensions, see page 187.

Only 50 and 180 sizes of the models listed will be converted to the new GEN 2 design. 210 size will continue to be offered in the original design and will not be converted.

UM-C Series UniModule – Ceramic Faced

UM-2030-C Brake/Input Clutch Combination

UM-2030-C-B Brake/Input Clutch Combination–Base Mounted

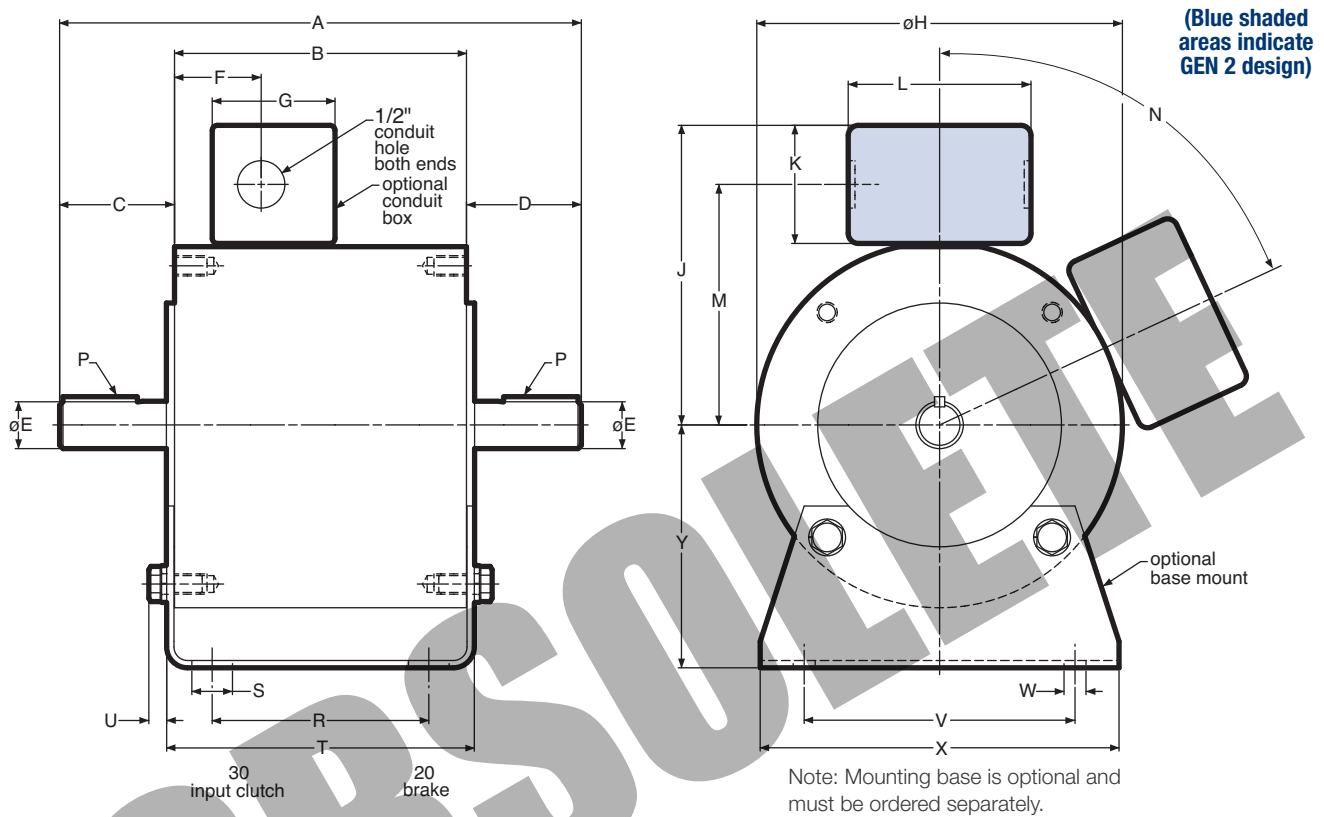

Dimensions (Blue shaded areas indicate GEN 2 design)

Size	A	B	C	D	E	F	G	H	J	K	L	M
50	9.492	5.390	2.062	2.040	.625	1.600	2.267	6.750	5.516	2.180	3.250	4.426
180	9.632	5.390	2.121	2.121	.875	1.600	2.267	6.750	5.516	2.180	3.250	4.426
210	12.969	7.719	2.500	2.500	1.125	1.812	2.267	9.250	6.859	2.180	3.250	5.766

Size	N	P	R	S	T	U	V	W	X	Y
50	0°	3/16 x 3/16	4.000	.800	5.680	.329	5.000	.406	6.000	3.500
180	0°	3/16 x 3/16	4.000	.750	5.680	.329	5.000	.406	6.625	4.500
210	65°	1/4 x 1/4	6.000	.750	8.260	.437	7.750	.534	9.000	5.250

For standard NEMA frame dimensions, see page 187.

Specifications (Blue shaded areas indicate GEN 2 design)

UniModule Size	Static Torque lb. ft.	Horsepower	Max. RPM	Voltage DC	NEMA Frame Size
UM50-C	16	1/4-3/4	3600	6, 24 and 90	56C/48Y
UM180-C	30	1-2	3600	6, 24 and 90	182C/143TC 184C/145TC
UM210-C	95	3-5	3600	6, 24 and 90	213/182TC 215C/184TC

For standard NEMA frame dimensions, see page 187.

Only 50 and 180 sizes of the models listed will be converted to the new GEN 2 design. 210 size will continue to be offered in the original design and will not be converted.

EUM Series Enclosed UniModule

EUM Series Clutch/Brakes and Clutch Combinations

Totally Enclosed Version

The Enclosed UniModule (EUM) packages the hardworking components from EM and UM products into a totally enclosed housing. This rugged housing keeps wear particles in and contaminants out and provides quiet operation. Pre-aligned at the factory, and pre-burnished for rated torque directly out-of-box.

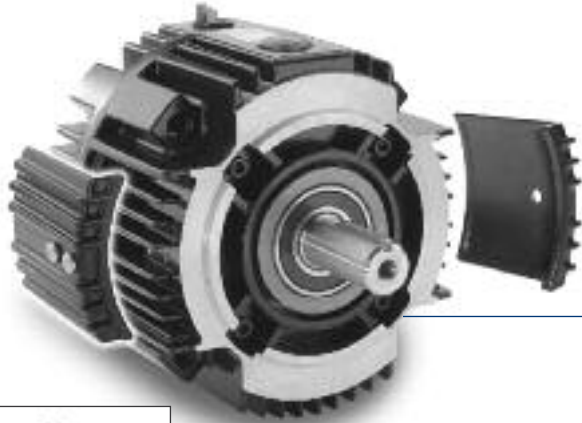

For 50, 100 and 180 Sizes

Enclosed UniModules, (EUMs) for 50, 100, and 180 sizes, are being replaced by GEN 2 UniModules (UMs) and an easy to install cover kit.



GEN 2 Design

For 210 and 215 Sizes

Original EUM (black) units are totally enclosed. They are suitable for most industrial applications and tolerate infrequent, light washing. They have aluminum endbells and a finned housing for rapid heat dissipation.



Original Design

EUM Series Enclosed UniModule

50, 100, and 180 sizes

Contamination-Resistant Design

Clean, quiet, operation. Nothing can get in, nothing can get out. Enclosed design eliminates damage to the working components. Prevents friction wear particles from escaping.

Totally Enclosed Version

The Enclosed UniModule (EUM) packages the hardworking components from UM products into a totally enclosed housing. This rugged housing keeps wear particles in and contaminants out and provides quiet operation. Pre-burnished at the factory for rated torque directly out-of-box. When enclosed, they are suitable for most industrial applications and tolerate infrequent, light washing.

- Keeps contaminants out
- Keeps wear particles in
- Quiet operation
- Finned for heat dissipation
- UL listed when optional conduit box is installed

To convert any Gen 2 UniModule 50, 100, and 180 sizes to an EUM, purchase optional Cover Kit

(part number 5370-101-076)

Enclosed UniModule Conversion

Enclosed UniModules, (EUMs) for 50, 100, and 180 sizes, are being replaced by GEN 2 UniModules (UMs) and an easy to install cover kit. Each kit contains (2) vent covers, (2) gaskets and (4) screws. A vent cover bolts to both sides of the UniModule unit to enclose the open vents of the housing creating a totally enclosed (non-washdown) brake package which keeps contaminants out and wear particles in for clean, quiet operation.

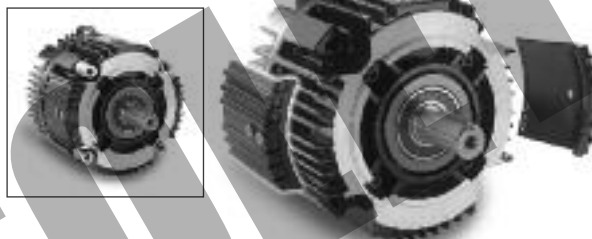

GEN 2 Heat Dissipation Curves

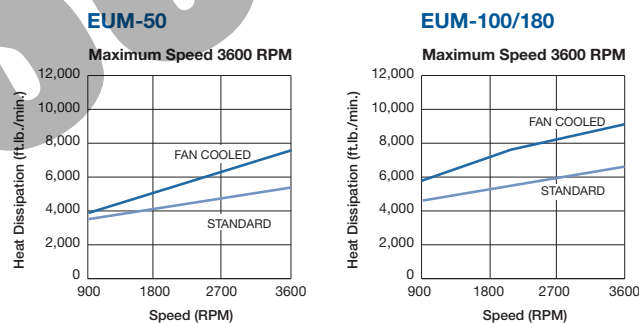

Note: For ORIGINAL DESIGN EUM 50,100 and 180 curves, see page 62.

How To Order

GEN 2 EUM models can be ordered in the following two ways:

1. Combined part number, UniModule including cover kit (ex. 5370-15)
2. Separate part numbers, UniModule and cover kit (ex. 5370-273-201 and 5370-101-076)

Totally Enclosed EUM Model No.	Voltage D.C.	Original Design Part No.	COMBINED OR SEPARATE	
			GEN 2 Part No. UniModule w/kit	GEN 2 Part Numbers UniModule and Cover Kit
1020 Configuration				
EUM-50-1020	6	5370-273-058	5370-15	5370-273-201 and 5370-101-076
	24	5370-273-059	5370-16	5370-273-203 and 5370-101-076
	90	5370-273-057	5370-17	5370-273-204 and 5370-101-076
EUM-100-1020	6	5370-273-092	5370-18	5370-273-206 and 5370-101-076
	24	5370-273-093	5370-19	5370-273-208 and 5370-101-076
	90	5370-273-091	5370-20	5370-273-209 and 5370-101-076
EUM-180-1020	6	5370-273-066	5370-21	5370-273-211 and 5370-101-076
	24	5370-273-067	5370-22	5370-273-213 and 5370-101-076
	90	5370-273-065	5370-23	5370-273-214 and 5370-101-076
1040 Configuration				
EUM-50-1040	90	5370-271-050	5370-24	5370-271-204 and 5370-101-076
EUM-180-1040	90	5370-271-051	5370-25	5370-271-214 and 5370-101-076
2030 Configuration				
EUM-50-2030	6	5370-273-062	5370-26	5370-273-216 and 5370-101-076
	24	5370-273-063	5370-27	5370-273-218 and 5370-101-076
	90	5370-273-061	5370-28	5370-273-219 and 5370-101-076
EUM-180-2030	6	5370-273-070	5370-29	5370-273-226 and 5370-101-076
	24	5370-273-071	5370-30	5370-273-228 and 5370-101-076
	90	5370-273-069	5370-31	5370-273-229 and 5370-101-076

EUM Series Enclosed UniModule

210 and 215 sizes

Clean, quiet, operation. Nothing can get in, nothing can get out. Enclosed design eliminates damage to the working components. Prevents friction wear particles from escaping.

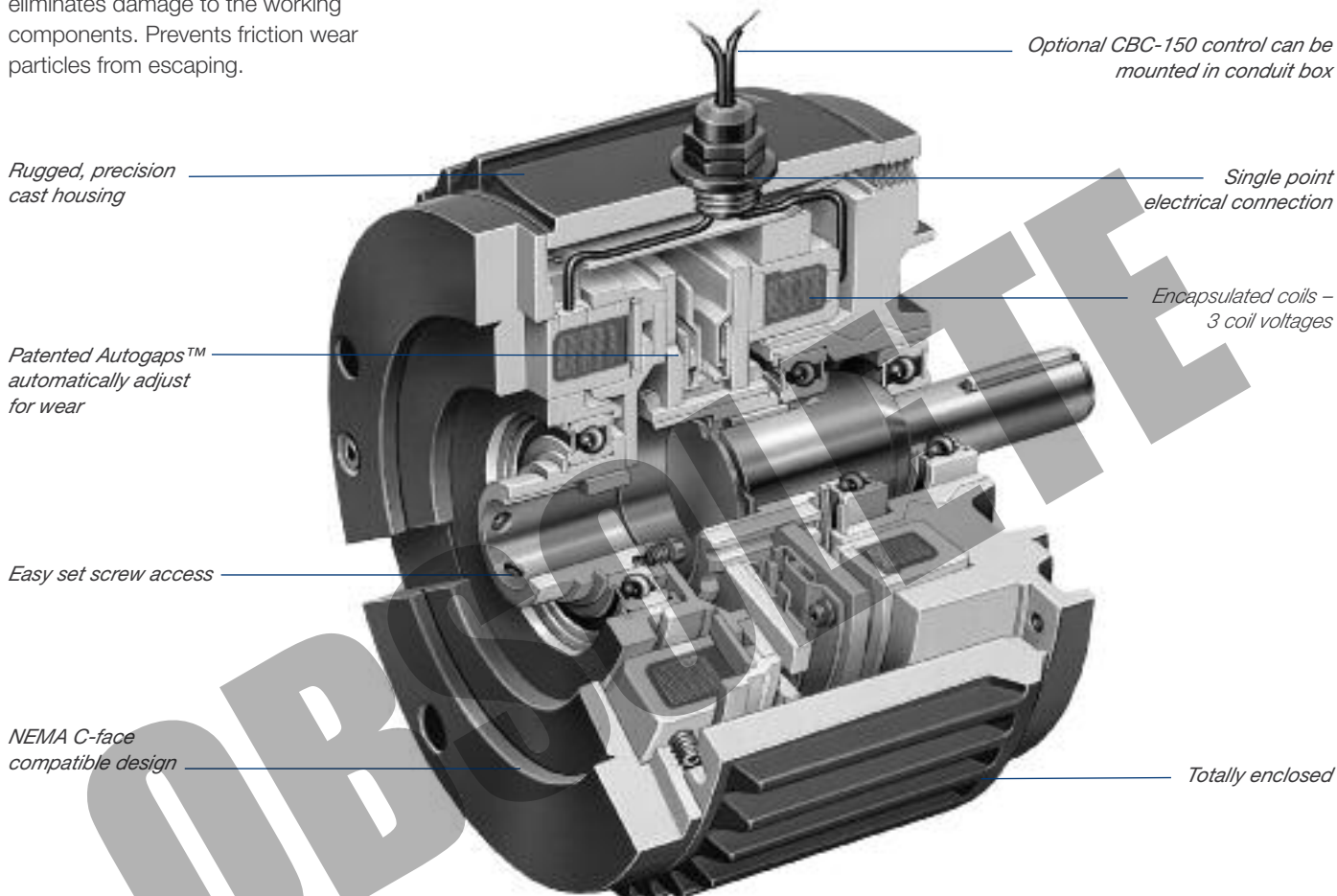

One piece, C-face package completely assembled and factory aligned. Mates easily with standard motors and reducers. Foot mounted package also available. Easy-to-install and no maintenance required.

Bolt-it-down, wire-it-up. UniModule is ready to go. Automatic adjustment for wear. Complete control capability.

Available with built-in power supply or used with separate controls for soft starts and stops . . . or for fast acting, accurate cycling.

- Factory burnished for out-of-box torque
- Superior heat transfer
- Dual endbell for easy repair
- Single point electrical connection
- Optional conduit box
- Optional integral control

Improved Hub Design/Autogap System

- Improved for longer spline life
- Autogap functions over broad current range
- New hub material

EUM Totally Enclosed

EUM (black) units are totally enclosed to keep wear particles in and exclude contaminants and are suitable for most industrial applications.

EUM Series Enclosed UniModule

Selection

EUM - Selection Procedure

Warner Electric EUM clutch/brake modules normally mount in either of two methods: NEMA C-face mounting or base mounting.

1. Select Configuration



a. NEMA C-face Mounting (1020 and 1040 Configurations)

Based on the NEMA C-face frame size of the prime mover, select the corresponding clutch/brake package size from the Frame Size Selection chart. Size 100 houses the components of the size 180 in a size 50 frame, while size 215 incorporates size 210 components.

Select either a 1020 or a 1040 (EUM only) configuration. The 1020 is a clutch/brake, while the 1040 is a clutch only. The 2030 configuration is a clutch/brake for base mounting.

Frame Size Selection

NEMA Frame Size	EUM Size
56C/48Y	EUM-50* EUM-100**
182C/143TC 184C/145TC	EUM-180
213C/182TC 215C/184TC	EUM-210
213TC/215TC	EUM-215

* For 56C/48Y Frame motors 3/4 HP and smaller the EUM-100 size may be used where extended life is desirable.
** EUM-100 size is recommended for motors 1 HP and larger.

b. Base Mounting (2030 Configuration)



Enclosed UniModule assemblies may be mounted as separate drive units driven from the prime mover by V-belts, chain and sprockets, couplings, timing belts and other standard power transmission components.

Select the correct size 2030 package from the Horsepower vs. Shaft Speed chart by determining the motor horsepower and RPM at the module location. The correct size EUM is shown at the intersection of the HP and operating speed. For additional sizing information, refer to the technical sizing procedure (step 2).

2. Determine Technical Requirements

Technical considerations for sizing and selection are torque and heat dissipation. Each merits careful consideration, especially heat dissipation as over time, use in excessive temperature environments will have an adverse effect on bearing life and coil wire insulation integrity.

Compare the calculated torque requirement with the average dynamic torque ratings. Select a unit with adequate torque. If the unit selected on torque is different than the unit selected based on heat, select the larger size unit.

Two heat dissipation curves are shown. A fan kit accessory is available for use with these units.

Horsepower vs. Shaft Speed

HP	SHAFT SPEED AT CLUTCH (IN RPM)																		
	100	200	300	400	500	600	700	800	900	1000	1100	1200	1500	1800	2000	2400	3000	3600	
1/4																			
1/2																			
3/4																			
1																			
1-1/2																			
2																			
3																			
5																			
7-1/2																			
10																			

a. Heat Dissipation Sizing

Friction surfaces slip during the initial period of engagement and, as a result, heat is generated. The clutch/brake selected must have a heat dissipation rating greater than the heat generated by the application. Therefore, in high inertia or high cycle rate applications, it is necessary to check the heat dissipation carefully. Inertia, speed and cycle rate are the required parameters.

Heat dissipation requirement is calculated as follows:

$$E = 1.7 \times WR^2 \times (N/100)^2 \times F$$

where:

$$E = \text{Heat (lb. ft./min.)}$$

WR^2 = Total reflected inertia at the clutch/brake shaft. Include the clutch/brake output inertia. (lb.ft.²)

N = Speed in revolutions per minute (RPM)

F = Cycle rate in cycles per minute (CPM)

Compare the calculated heat generated in the application to the unit ratings using the heat dissipation curves. Select the appropriate unit that has adequate heat dissipation ability.

Enclosed UniModule Heat Dissipation Curves

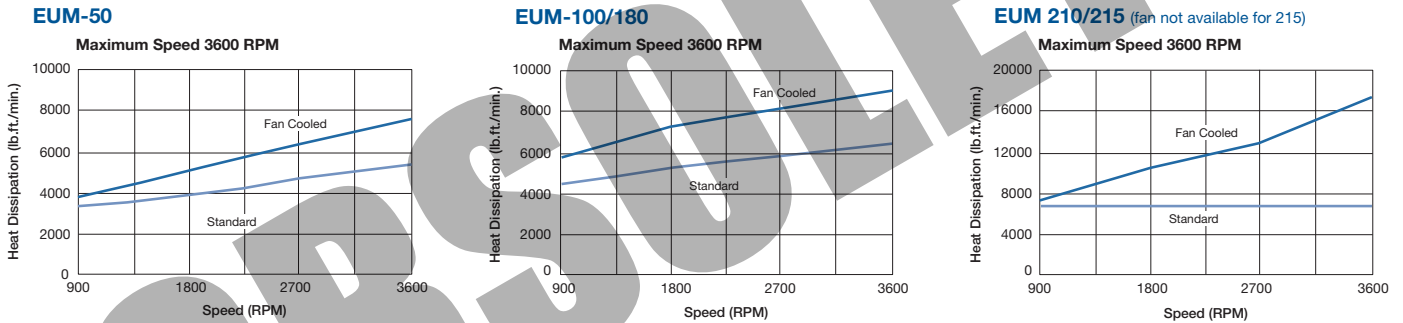

b. Torque Sizing

For most applications, the correct size clutch/brake can be selected from the Horsepower vs. Shaft Speed chart.

Determine the motor horsepower and the RPM at the clutch/brake. The correct size unit is shown at the intersection of horsepower and shaft speed.

If the static torque requirements are known, refer to the Specifications Table to select a unit.

For some applications, the torque requirement is determined by the time allowed to accelerate and decelerate the load. (This time is generally specified in milliseconds.) For these applications, it is necessary to determine the torque requirement based on load inertia and the time allowed for engagement.

The torque requirements are calculated as follows:

$$T = (WR^2 \times N) / (308 \times t)$$

where:

T = Average Dynamic Torque (lb. ft.)

WR^2 = Total reflected inertia at the clutch/brake shaft. Include the clutch/brake output inertia. (lb. ft.²)

N = Speed in revolutions per minute (RPM)

t = Time allowed for the engagement (sec)

C-face Clutch/Power-on Brake Dynamic Torque Curves

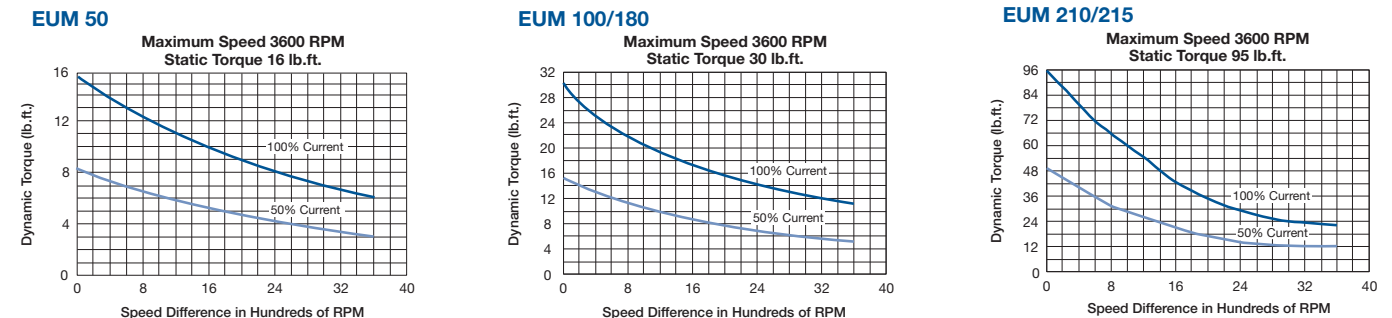

EUM Series Enclosed UniModule

Specifications

UniModule Size	Shaft Dia.	Static Torque lb. ft.	Horsepower	Max. RPM	Voltage DC	NEMA Frame Size
EUM50	.625	16	1/4-3/4	3600	6, 24 and 90	56C/48Y
EUM100	.625	30	1-2	3600	6, 24 and 90	56C/48Y
EUM180	.875	30	1-2	3600	6, 24 and 90	182C/143TC 184C/145TC
EUM210	1.125	95	3-5	3600	6, 24 and 90	213/182TC 215C/184TC
EUM215	1.375	95	7-1/2-10	3600	6, 24 and 90	213TC/215TC

Accessories

Warner Electric Enclosed UniModules can be fitted with several accessories to extend their capacity and ease of mounting.

Conduit Box

NEMA 4 and UL listed, available in standard and washdown versions.



Integral Control

The CBC-150 dual channel control fits into the cover of the conduit box. It is suitable for AC side switching (triac or relay) and includes high performance suppression.

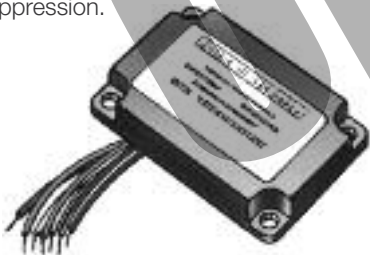

Fan Kit (UM and EUM 1020 only)

Extends the thermal capacity of an EUM. Mounts between motor and EUM, includes shaft, fan, guard and hardware. Available in standard black coating or food grade approved white coating.



Mounting Brackets

Two styles of mounting brackets are available for simplified installation. The base mount is used with the 2030 configuration. A motor mount is also available and provides sturdy support for a 1020 or 1040 combination with motor.

(Optional)

Motor Mount (M)

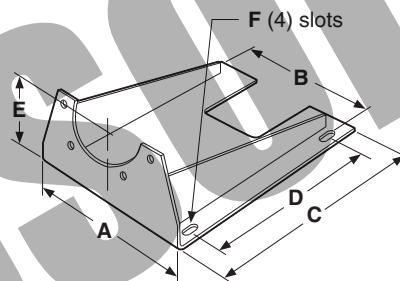

For use with 1020 and 1040 Combinations.

Size	A	B	C	D	E	F	Part No.
50/100	9.25	8.25	11.00	8.000	3.50	.797 x .406	5370-101-078
180	9.25	8.25	11.00	8.000	4.50	.797 x .406	5370-101-079
210/215	11.50	10.50	12.00	9.000	5.25	.750 x .406	5371-101-012

Base (B)

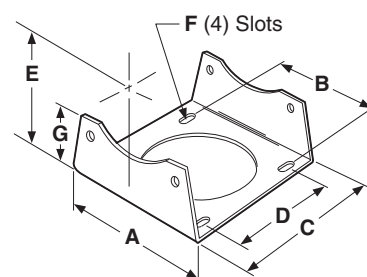

For use with 2030 and 3040 units.

Size	A	B	C	D	E	F	G	Part No.
50/100	6.000	5.000	5.672	4.000	3.500	.750 x .406	2.000	5370-101-004
180	6.625	5.000	5.672	4.000	4.500	.750 x .406	3.000	5370-101-002
210/215	9.000	7.750	8.203	6.000	5.250	.750 x .531	3.385	5371-101-001

EUM Series Enclosed UniModule

Selection and Ordering Information

Part Numbers

Totally Enclosed EUM Model No.	Voltage D.C.	Original Design Part No.	OR		SEPARATE GEN 2 Part Numbers	
			COMBINED GEN 2 Part No. UniModule w/kit		UniModule	and Cover Kit
1020 Configuration – Enclosed EUM						
EUM-50-1020	6	5370-273-058	5370-15		5370-273-201 and 5370-101-076	
	24	5370-273-059	5370-16		5370-273-203 and 5370-101-076	
	90	5370-273-057	5370-17		5370-273-204 and 5370-101-076	
EUM-100-1020	6	5370-273-092	5370-18		5370-273-206 and 5370-101-076	
	24	5370-273-093	5370-19		5370-273-208 and 5370-101-076	
	90	5370-273-091	5370-20		5370-273-209 and 5370-101-076	
EUM-180-1020	6	5370-273-066	5370-21		5370-273-211 and 5370-101-076	
	24	5370-273-067	5370-22		5370-273-213 and 5370-101-076	
	90	5370-273-065	5370-23		5370-273-214 and 5370-101-076	
EUM-210-1020	6	5371-273-028				
	24	5371-273-029				
	90	5371-273-027				
EUM-215-1020	6	5371-273-082				
	24	5371-273-083				
	90	5371-273-084				
20 Configuration (Power On Brake Only) – Enclosed EUM						
EUM-210-20	24	5371-169-105				
	90	5371-169-104				
EUM-215-20	24	5371-169-105				
	90	5371-169-104				
1040 Configuration – Enclosed EUM						
EUM-50-1040	90	5370-271-050	5370-24		5370-271-204 and 5370-101-076	
EUM-180-1040	90	5370-271-051	5370-25		5370-271-214 and 5370-101-076	
EUM-210-1040	90	5371-271-024				
2030 Configuration – Enclosed EUM						
EUM-50-2030	6	5370-273-062	5370-26		5370-273-216 and 5370-101-076	
	24	5370-273-063	5370-27		5370-273-218 and 5370-101-076	
	90	5370-273-061	5370-28		5370-273-219 and 5370-101-076	
EUM-180-2030	6	5370-273-070	5370-29		5370-273-226 and 5370-101-076	
	24	5370-273-071	5370-30		5370-273-228 and 5370-101-076	
	90	5370-273-069	5370-31		5370-273-229 and 5370-101-076	
EUM-210-2030	6	5371-273-032				
	24	5371-273-083				
	90	5371-273-031				

Accessories

Option	Size	Enclosed UniModule
Conduit box	All sizes	5370-101-042
Control	CBC-150-1	6004-448-001
	CBC-150-2	6004-448-002
Base Mount Kits for 2030	50	5370-101-004
	50/180*	5370-101-002
	210	5371-101-001
Motor Mount Kits for 1020, 1040, 20	50/100	5370-101-078
	50/100/180*	5370-101-079
	210/215	5371-101-012
Fan Kits for 1020, 1040	50/100	5370-101-055
	180	5370-101-054
	210	5371-101-029

* Because of diameter limitations, bases for original design EUMs are available in 4.5" center height (143/145TC) only.

How to Order

Motor or Reducer Mounted

Simply combine the size number with the configuration of the required UniModule. Specify voltage. See chart for specific part numbers. Order optional conduit box if desired.

Example

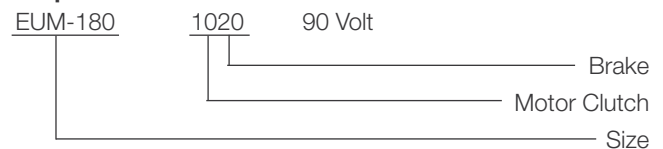

Base Mounted

Simply combine the size number with the configuration of the required UniModule. Specify voltage. See chart for specific part numbers. Order optional conduit box if desired.

Example

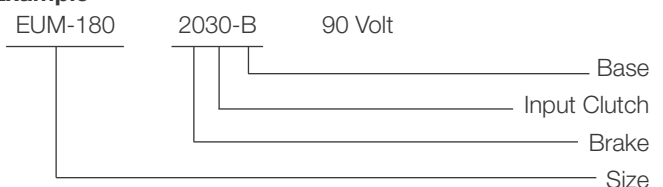

EUM Series Enclosed UniModule

EUM-1020 Motor Clutch/Brake Combination

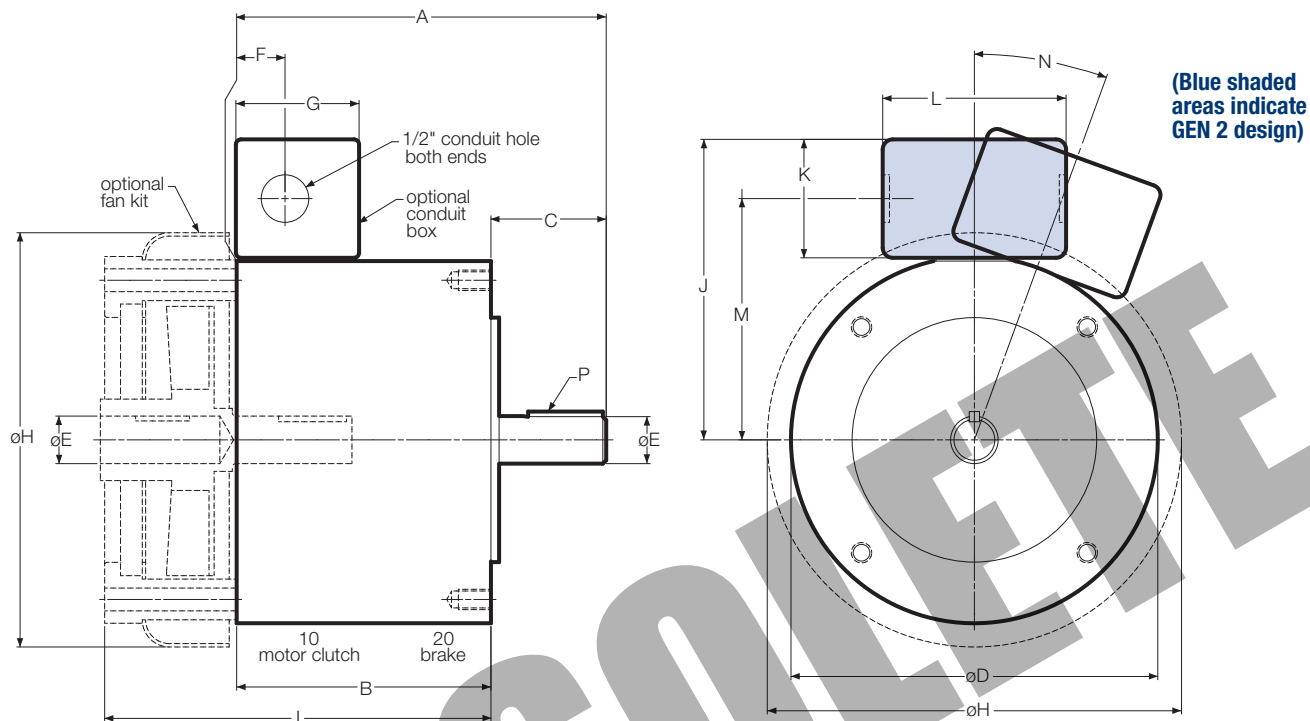

Dimensions (Blue shaded areas indicate GEN 2 design)

Size	A	B	C	D	E	F	G	H
50	6.720	4.680	2.040	6.750	.625	.890	2.267	7.620
100	6.741	4.680	2.061	6.750	.625	.890	2.267	7.620
180	6.801	4.680	2.121	6.750	.875	.890	2.267	7.620
210	9.391*	6.422*	2.500	10.000	1.125	3.053	2.267	10.187
215	9.391*	6.422*	2.500	10.000	1.375	3.053	2.267	10.187

Size	I	J	K	L	M	N	P
50	7.110	5.516	2.180	3.250	4.426	0°	3/16 x 3/16
100	7.110	5.516	2.180	3.250	4.426	0°	3/16 x 3/16
180	7.110	5.516	2.180	3.250	4.426	0°	3/16 x 3/16
210	9.297	7.146	2.180	3.250	6.056	35°	1/4 x 1/4
215	9.297	7.146	2.180	3.250	6.056	35°	5/16 x 5/16

* Dimension includes the .500 thick adapter required for mounting to a C-face motor.

Specifications (Blue shaded areas indicate GEN 2 design)

Model Size	Voltage DC	Static Torque lb. ft.	Max. RPM	NEMA Frame Size
50	6, 24, 90	16	3600	56C/48Y*
100	6, 24, 90	30	3600	56C/48Y**
180	6, 24, 90	30	3600	182C/143TC 184C/145TC
210	6, 24, 90	95	3600	213C/182TC 215C/184TC
215	6, 24, 90	95	3600	213TC/215TC

* For 56C/48Y Frame motors 3/4 HP and smaller the UM-100 size may be used where extended life is desirable.

** UM-100 size is recommended for motors 1 HP and larger.

For standard NEMA frame dimensions, see page 187.

Only 50, 100, and 180 sizes of the models listed will be converted to the new GEN 2 design. 210 and 215 sizes will continue to be offered in the original design and will not be converted.

EUM Series Enclosed UniModule

EUM-1040 Motor Clutch/Output Clutch Combination

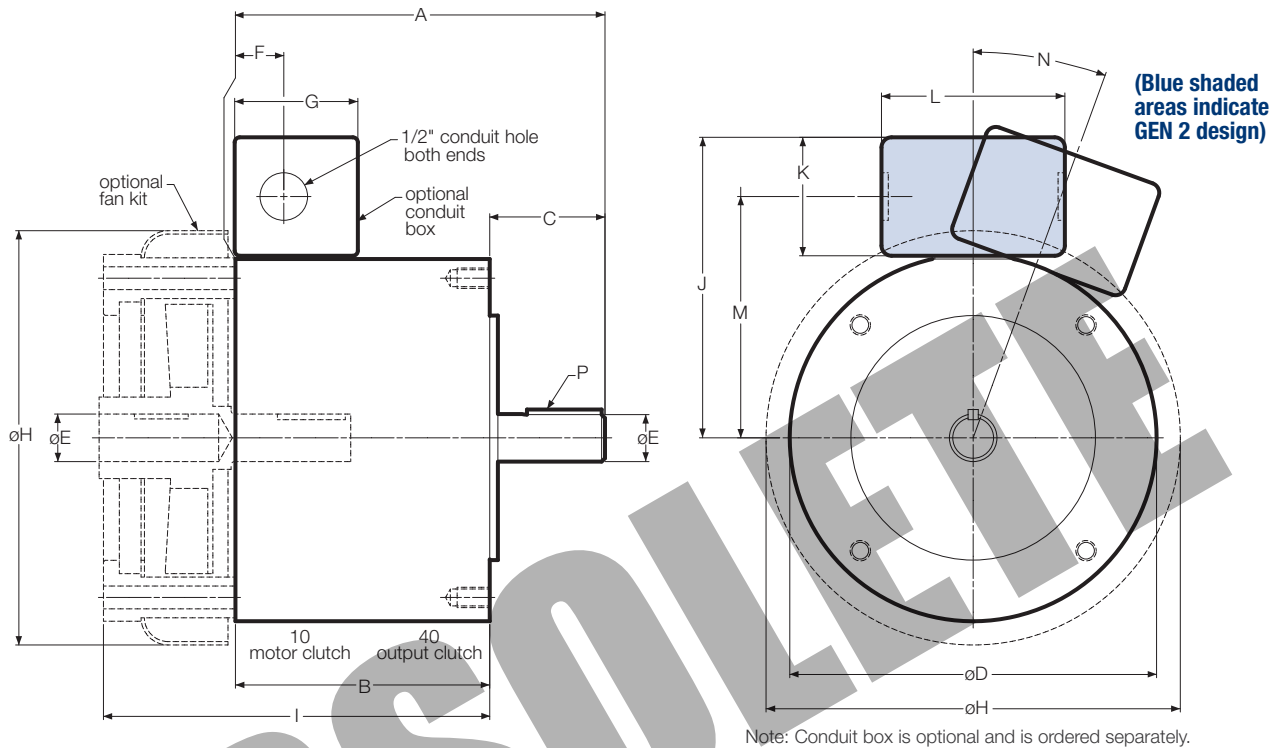

Dimensions (Blue shaded areas indicate GEN 2 design)

Size	A	B	C	D	E	F	G	H
50	6.720	4.680	2.040	6.750	.625	.890	2.267	7.620
180	6.801	4.680	2.121	6.750	.875	.890	2.267	7.620
210	9.391*	6.422*	2.500	10.000	1.125	3.053	2.267	10.187

Size	I	J	K	L	M	N	P
50	7.110	5.516	2.180	3.250	4.426	0°	3/16 x 3/16
180	7.110	5.516	2.180	3.250	4.426	0°	3/16 x 3/16
210	9.297	7.146	2.180	3.250	6.056	35°	1/4 x 1/4

* Dimension includes the .500 thick adapter required for mounting to a C-face motor.

Specifications (Blue shaded areas indicate GEN 2 design)

Model Size	Voltage DC	Static Torque lb. ft.	Max. RPM	NEMA Frame Size
50	90	16	3600	56C/48Y
180	90	30	3600	182C/143TC 184C/145TC
210	90	95	3600	213C/182TC 215C/184TC

For standard NEMA frame dimensions, see page 187.

Only 50 and 180 sizes of the models listed will be converted to the new GEN 2 design. 210 size will continue to be offered in the original design and will not be converted.

EUM Series Enclosed UniModule

EUM-2030 Input Clutch/Brake Combination

EUM-2030-B Input Clutch/Brake Combination – Base Mounted

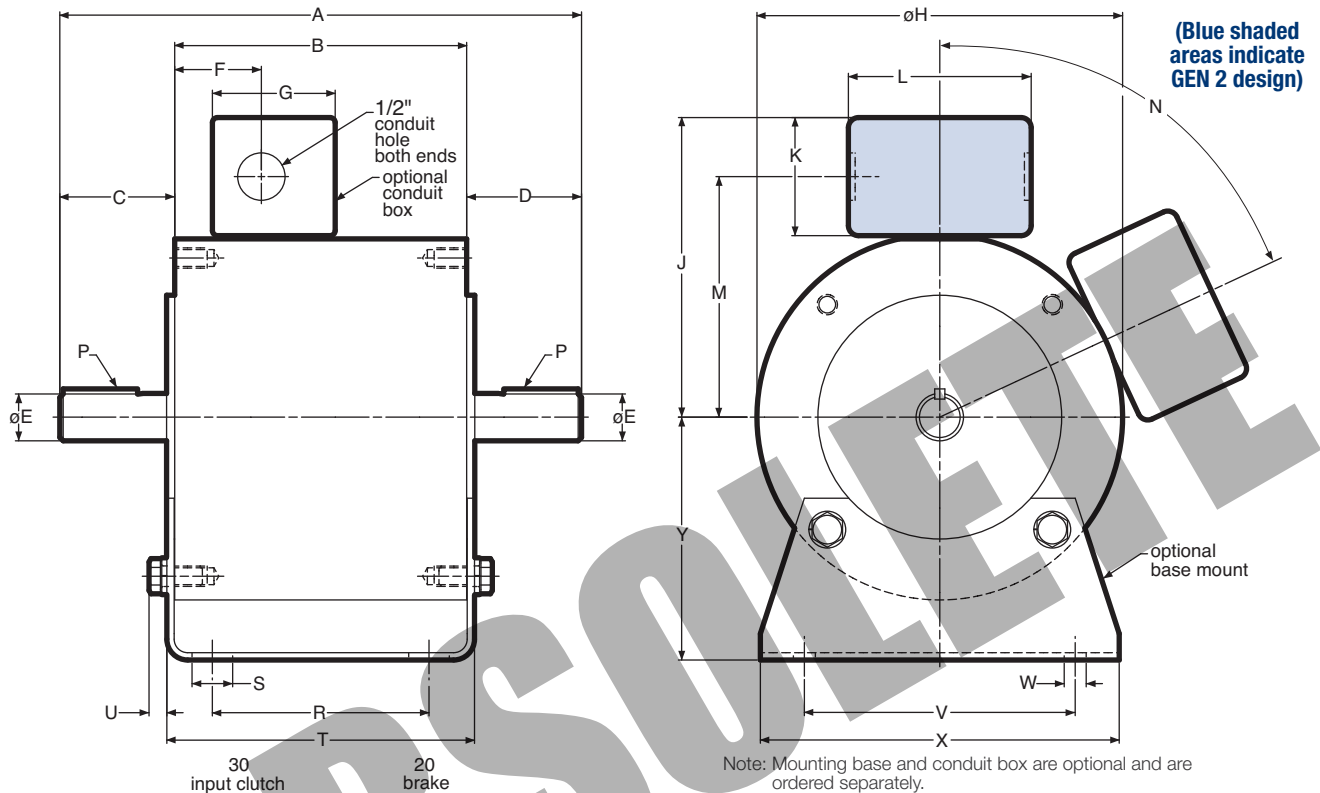

Dimensions (Blue shaded areas indicate GEN 2 design)

Size	A	B	C	D	E	F	G	H	J	K	L	M
50	9.492	5.390	2.062	2.040	.625	1.600	2.267	6.750	5.516	2.180	3.250	4.426
180	9.632	5.390	2.121	2.121	.875	1.600	2.267	6.750	5.516	2.180	3.250	4.426
210	12.969	7.719	2.500	2.500	1.125	4.514	2.267	10.000	7.146	2.180	3.250	6.056

Size	N	P	R	S	T	U	V	W	X	Y
50	0°	3/16 x 3/16	4.000	.800	5.680	.329	5.000	.406	6.000	3.500
180	0°	3/16 x 3/16	4.000	.750	5.680	.329	5.000	.406	6.625	4.500
210	35°	1/4 x 1/4	6.000	.750	8.260	.437	7.750	.534	9.000	5.250

Specifications (Blue shaded areas indicate GEN 2 design)

Model Size	Voltage DC	Static Torque lb. ft.	Max. RPM	NEMA Frame Size
50	6, 24, 90	16	3600	56C/48Y
180	6, 24, 90	30	3600	182C/143TC 184C/145TC
210	6, 24, 90	95	3600	213C/182TC 215C/184TC

For standard NEMA frame dimensions, see page 187.

Only 50 and 180 sizes of the models listed will be converted to the new GEN 2 design.
210 size will continue to be offered in the original design and will not be converted.

EUM-W Series Enclosed UniModule

Contamination-Proof Design

Clean, quiet, operation. Nothing can get in, nothing can get out. Enclosed design eliminates damage to the working components. Prevents friction wear particles from escaping.

Rugged, precision cast housing

Patented Autogaps™ automatically adjust for wear

Easy set screw access

NEMA C-face compatible design



Optional CBC-150 control can be mounted in conduit box

Single point electrical connection

Encapsulated coils – 3 coil voltages

Totally enclosed

One piece, C-face package completely assembled and factory aligned. Mates easily with standard motors and reducers. Foot mounted package also available. Easy-to-install and no maintenance required.

Bolt-it-down, wire-it-up. UniModule is ready to go. Automatic adjustment for wear. Complete control capability.

Available with built-in power supply or used with separate controls for soft starts and stops . . . or for fast acting, accurate cycling.

- Factory burnished for out-of-box torque
- Superior heat transfer
- Dual endbell for easy repair
- Single point electrical connection
- Optional conduit box
- Optional integral control

Improved Hub Design/Autogap System

- Improved for longer spline life
- Autogap functions over broad current range
- New hub material

EUM-W Washdown Unit

EUM-W (white) units are ideal for applications that require frequent washing with high pressure spray systems.

EUM-W Series Enclosed UniModule

EUM-W Series Clutch/Brakes and Clutch Combinations

EUM-W Series Clutch/Brakes Washdown Unit

The washdown version of the EUM uses stainless steel shafting, USDA approved coating, corrosion resistant fasteners and special sealing accessories for use in washdown applications.

EUM-W (white) units are ideal for applications that require frequent washing with high pressure spray systems. Their smooth exterior does not allow food particles, or other contaminants, to get trapped and become host to bacteriological growth.

- USDA approved coating
- Stainless steel shafting
- Sealing (gaskets and plugs)
- Smooth exterior – easy washdown
- Corrosion resistant hardware
- Sealed/shielded bearings
- Baffled ventilation system
- Designed for IP65 enclosure requirements
- UL listed when conduit box is employed



EUM-W - Selection Procedure

Warner Electric EUM-W clutch/brake modules normally mount in either of two methods: NEMA C-face mounting or base mounting.

1. Select Configuration

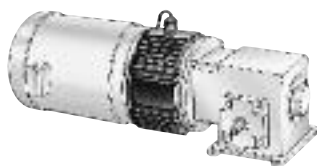

a. NEMA C-face Mounting (1020 and 1040 Configurations)

Based on the NEMA C-face frame size of the prime mover, select the corresponding clutch/brake package size from the Frame Size Selection chart. Size 100 houses the components of the size 180 in a size 50 frame, while size 215 incorporates size 210 components.

Select either a 1020 or a 1040 (EUM-W only) configuration. The 1020 is a clutch/brake, while the 1040 is a clutch only. The 2030 configuration is a clutch/brake for base mounting.

Frame Size Selection

NEMA Frame Size	EUM-W Size
56C/48Y	EUM50-W* EUM100-W**
182C/143TC	EUM180-W
184C/145TC	
213C/182TC	EUM210-W
215C/184TC	
213TC/215TC	EUM215-W

* For 56C/48Y Frame motors 3/4 HP and smaller the EUM100-W size may be used where extended life is desirable.

** EUM100-W size is recommended for motors 1 HP and larger.

b. Base Mounting (2030 Configuration)



Washdown enclosed UniModule assemblies may be mounted as separate drive units driven from the prime mover by V-belts, chain and sprockets, couplings, timing belts and other standard power transmission components.

Select the correct size 2030 package from the Horsepower vs. Shaft Speed chart by determining the motor horsepower and RPM at the module location. The correct size EUM-W is shown at the intersection of the HP and operating speed. For additional sizing information, refer to the technical sizing procedure (step 2).

Horsepower vs. Shaft Speed

HP	SHAFT SPEED AT CLUTCH (IN RPM)																
	100	200	300	400	500	600	700	800	900	1000	1100	1200	1500	1800	2000	2400	3000
1/4	EUM50-W																
1/2	EUM50-W																
3/4	EUM100/180-W																
1	EUM100/180-W																
1-1/2	EUM100/180-W																
2	EUM210/215-W																
3	EUM210/215-W																
5	EUM210/215-W																
7-1/2	EUM210/215-W																
10	EUM210/215-W																

2. Determine Technical Requirements

Technical considerations for sizing and selection are torque and heat dissipation. Each merits careful consideration, especially heat dissipation as over time, use in excessive temperature environments will have an adverse effect on bearing life and coil wire insulation integrity.

Compare the calculated torque requirement with the average dynamic torque ratings. Select a unit with adequate torque. If the unit selected on torque is different than the unit selected based on heat, select the larger size unit.

Two heat dissipation curves are shown. A fan kit accessory is available for use with these units.

EUM-W Series Enclosed UniModule

a. Heat Dissipation Sizing

Friction surfaces slip during the initial period of engagement and, as a result, heat is generated. The clutch/brake selected must have a heat dissipation rating greater than the heat generated by the application. Therefore, in high inertia or high cycle rate applications, it is necessary to check the heat dissipation carefully. Inertia, speed and cycle rate are the required parameters.

Heat dissipation requirement is calculated as follows:

$$E = 1.7 \times WR^2 \times (N/100)^2 \times F$$

where:

$$E = \text{Heat (lb. ft./min.)}$$

WR^2 = Total reflected inertia at the clutch/brake shaft. Include the clutch/brake output inertia. (lb.ft.²)

N = Speed in revolutions per minute (RPM)

F = Cycle rate in cycles per minute (CPM)

Compare the calculated heat generated in the application to the unit ratings using the heat dissipation curves. Select the appropriate unit that has adequate heat dissipation ability.

Washdown Enclosed UniModule Heat Dissipation Curves

EUM50-W

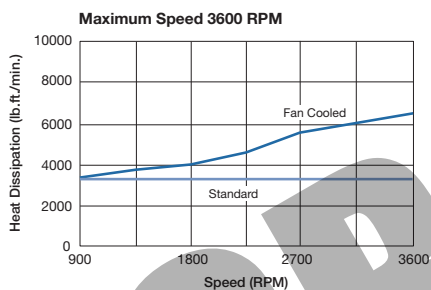

EUM100/180-W

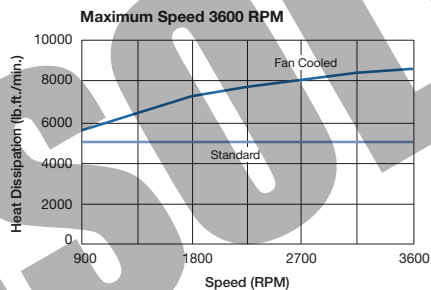

EUM210/215-W (fan not available for 215)

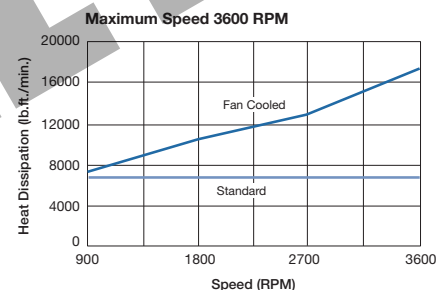

b. Torque Sizing

For most applications, the correct size clutch/brake can be selected from the Horsepower vs. Shaft Speed chart.

Determine the motor horsepower and the RPM at the clutch/brake. The correct size unit is shown at the intersection of horsepower and shaft speed.

If the static torque requirements are known, refer to the Specifications Table to select a unit.

For some applications, the torque requirement is determined by the time allowed to accelerate and decelerate the load. (This time is generally specified in milliseconds.) For these applications, it is necessary to determine the torque requirement based on load inertia and the time allowed for engagement.

The torque requirements are calculated as follows:

$$T = (WR^2 \times N) / (308 \times t)$$

where:

T = Average Dynamic Torque (lb. ft.)

WR^2 = Total reflected inertia at the clutch/brake shaft. Include the clutch/brake output inertia. (lb. ft.²)

N = Speed in revolutions per minute (RPM)

t = Time allowed for the engagement (sec)

C-face Clutch/Power-on Brake Dynamic Torque Curves

EUM50-W

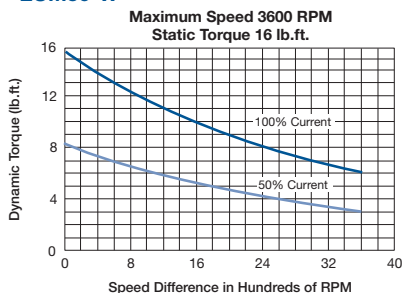

EUM100/180-W

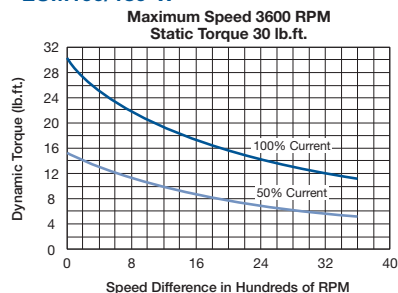

EUM210/215-W

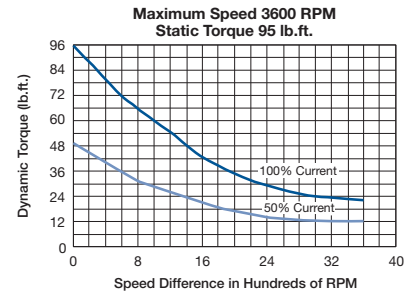

EUM-W Series Enclosed UniModule

Specifications

UniModule Size	Shaft Dia.	Static Torque lb. ft.	Horsepower	Max. RPM	Voltage DC	NEMA Frame Size
EUM50-W	.625	16	1/4-3/4	3600	6, 24 and 90	56C/48Y
EUM100-W	.625	30	1-2	3600	6, 24 and 90	56C/48Y
EUM180-W	.875	30	1-2	3600	6, 24 and 90	182C/143TC 184C/145TC
EUM210-W	1.125	95	3-5	3600	6, 24 and 90	213/182TC 215C/184TC
EUM215-W	1.375	95	7-1/2-10	3600	6, 24 and 90	213TC/215TC

3. Select Options

Accessories

Warner Electric Enclosed Washdown UniModules can be fitted with several accessories to extend their capacity and ease of mounting.

Conduit Box

NEMA 4 and UL listed, available in standard and washdown versions.

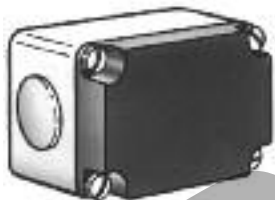

Integral Control

The CBC-150 dual channel control fits into the cover of the conduit box. It is suitable for AC side switching (triac or relay) and includes high performance suppression.



Fan Kit (UM and EUM 1020 only)

Extends the thermal capacity of an EUM-W. Mounts between motor and EUM-W, includes shaft, fan, guard and hardware. Available in standard black coating or food grade approved white coating.



Mounting Brackets

Two styles of mounting brackets are available for simplified installation. The base mount is used with the 2030 configuration. A motor mount is also available and provides sturdy support for a 1020 or 1040 combination with motor.

(Optional)

Motor Mount (M)

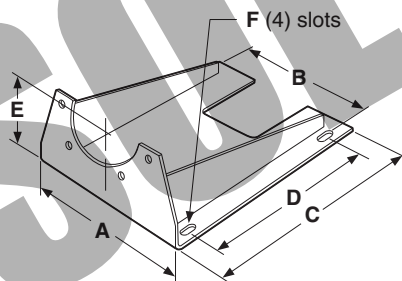

For use with 1020 and 1040 Combinations.

Size	A	B	C	D	E	F	Part No.
50/100/180*	9.25	8.25	10.50	8.000	4.50	.800 x .406	5370-101-080
210/215	11.50	10.50	12.00	9.000	5.25	.750 x .406	5371-101-026

* Because of diameter limitations, EUM-W bases are available in 4.5" center height (143/145TC) only.

Base (B)

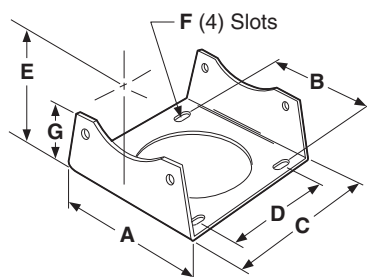

For use with 2030 and 3040 units.

Size	A	B	C	D	E	F	G	Part No.
50/180*	6.625	5.680	5.672	4.000	4.500	.750 x .406	3.000	5370-101-047
210	9.000	7.750	8.260	6.000	5.250	.750 x .531	3.375	5371-101-025

* Because of diameter limitations, EUM-W bases are available in 4.5" center height (143/145TC) only.

EUM-W Series Enclosed UniModule

Selection and Ordering Information

Part Numbers

Model No.	Voltage	Original Part No.
1020 Configuration – Washdown EUM-W		
EUM-50-1020W	6	5370-273-100
	24	5370-273-101
	90	5370-273-099
EUM-100-1020W	6	5370-273-108
	24	5370-273-109
	90	5370-273-107
EUM-180-1020W	6	5370-273-116
	24	5370-273-117
	90	5370-273-115
EUM-210-1020W	6	5371-273-056
	24	5371-273-057
	90	5371-273-055
EUM-215-1020W	6	5371-273-086
	24	5371-273-087
	90	5371-273-088
2030 Configuration – Washdown EUM-W		
EUM-50-2030W	6	5370-273-104
	24	5370-273-105
	90	5370-273-103
EUM-180-2030W	6	5370-273-120
	24	5370-273-121
	90	5370-273-119
EUM-210-2030W	6	5371-273-060
	24	5371-273-061
	90	5371-273-059

Accessories

Option	Size	Washdown UniModule
Conduit box	All sizes	5370-101-045
Control	CBC-150-1	6004-448-001
	CBC-150-2	6004-448-002
Base Mount Kits for 2030	50/180*	5370-101-047
	210	5371-101-025
Motor Mount Kits for 1020, 1040	50/100/180*	5370-101-080
	210/215	5371-101-026
Fan Kits for 1020	50/100	5370-101-060
	180	5370-101-061
	210	5371-101-033

* Because of diameter limitations, EUM bases are available in 4.5" center height (143/145TC) only.

How to Order

Motor or Reducer Mounted

Simply combine the size number with the configuration of the required UniModule. Specify voltage. See chart for specific part numbers. Order optional conduit box if desired.

Example

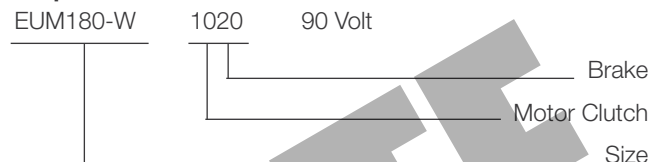

Base Mounted

Simply combine the size number with the configuration of the required UniModule. Specify voltage. See chart for specific part numbers. Order optional conduit box if desired.

Example

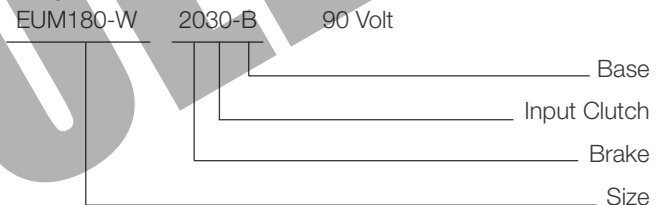

EUM-W Series Enclosed UniModule

EUM-W-1020 Clutch/Brake Combination

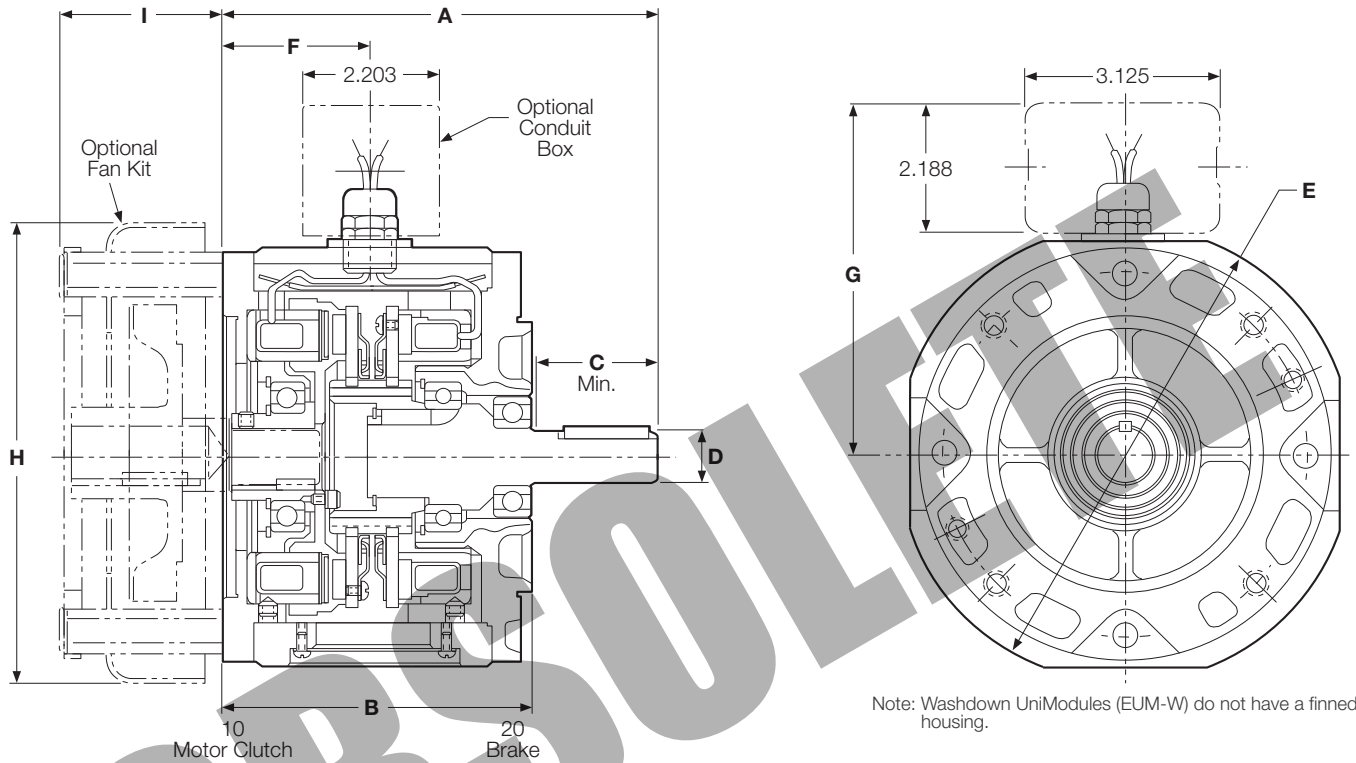

Dimensions

All dimensions are nominal, unless otherwise noted.

Size	A	B	C	D	E	F	G	H	I
50/100	6.750	4.844	1.813	.625	6.915	2.427	5.936	7.687	2.430
180	6.828	4.844	1.890	.875	6.915	2.427	5.936	7.687	2.430
210	8.891	5.922	2.500	1.125	10.00	3.053	7.146	10.187	3.375
215	9.391	5.922	3.000	1.375	10.00	3.053	7.146	10.187	3.375

Specifications

UniModule Size	Shaft Dia.	Horsepower	Static Torque lb. ft.	CPM @1750 RPM	Max. RPM	Voltage DC	NEMA Frame Size
EUM50-W	.625	1/4-3/4	16	125	3600	6, 24 or 90	56C/48Y
EUM100-W	.625	1	30	90	3600	6, 24 or 90	56C/48Y
EUM180-W	.875	1-2	30	90	3600	6, 24 or 90	182C/143TC 184C/145TC
EUM210-W	1.125	3-5	95	37	3600	6, 24 or 90	213/182TC 215C/184TC
EUM215-W	1.375	7-1/2	95	37	3600	6, 24 or 90	213TC/215TC

For NEMA standard frame dimensions, see page 187.

EUM-W Series Enclosed UniModule

EUM-W-2030 Clutch/Brake Combination—Base Mounted

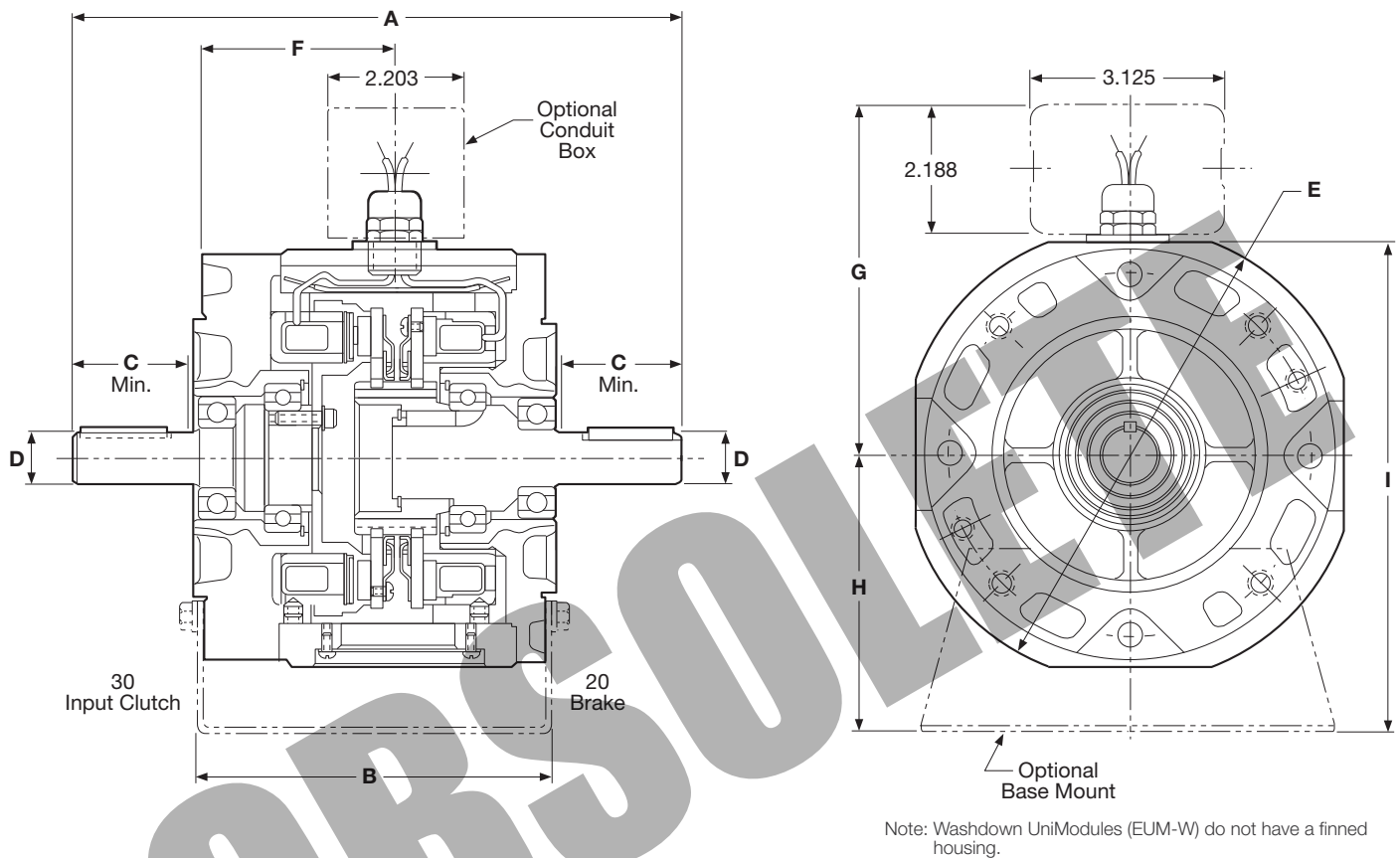

Dimensions

All dimensions are nominal, unless otherwise noted.

Size	A	B	C	D	E	F	G	H	I
50	9.516	5.672	1.813	.625	6.915	3.164	5.936	3.670	7.119
180	9.516	5.672	1.890	.875	6.915	3.164	5.936	4.484	8.119
210	12.969	8.260	2.500	1.125	10.00	4.514	7.146	5.234	10.234

Specifications

UniModule Size	Shaft Dia.	Horsepower	Static Torque lb. ft.	CPM @1750 RPM	Max. RPM	Voltage DC	NEMA Frame Size
EUM50-W	5/8"	1/4-3/4	16	125	3600	6, 24 or 90	56C/48Y
EUM100-W	5/8"	1	30	175	3600	6, 24 or 90	56C/48Y
EUM180-W	7/8"	1-2	30	175	3600	6, 24 or 90	182C/143TC 184C/145TC
EUM210-W	1-1/8"	3-5	95	32	3600	6, 24 or 90	213/182TC 215C/184TC

For NEMA standard frame dimensions, see page 187.

Shaft Mounted Clutches and Brakes

Shaft Mounted Clutches

EC Series

All the features of an electric clutch in a convenient, preassembled package. Mounts on any through shaft or double shafted motor. Easy-to-assemble with standard sheaves, pulleys, gears and sprockets.

Available in a wide range of bore sizes. Shaft extension makes pulley or sprocket installation easy.

Shaft Mounted Brakes

EB Series

Electro Brakes mount directly on a motor or through shaft for basic braking functions.

Torque arm feature makes Electro Brakes easy to install on any through shaft or double shaft motor.

Segmented and fluted armature disc provides maximum cooling of friction surfaces.

- Six sizes of clutches and brakes
- 16 lb. ft. to 465 lb. ft. torque range
- Preassembled. Factory aligned.
- Mounting flexibility
- Simple to install

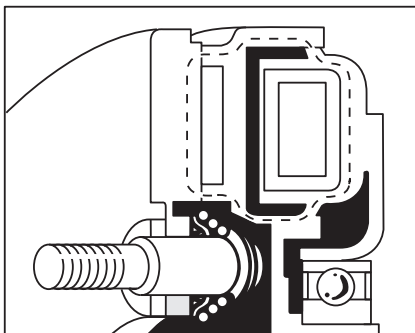

Brushless Design

Warner Electric designed electromagnetic circuit eliminates brushes.

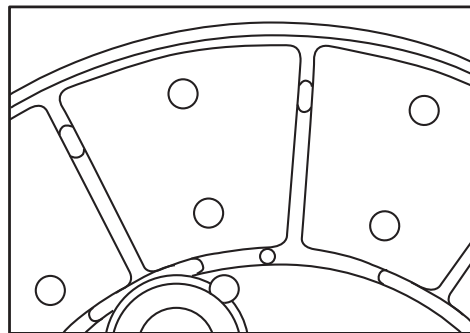

Heat Dissipation

Specially designed segmented armature disc is segmented and fluted to provide maximum cooling of friction surfaces. Automatically adjusts for wear.

Motor mounted Electro Clutch used in combination with an Electro Brake on a through shaft installation.

EC Series Electro Clutch

Shaft Mounted Clutches

Mounting flexibility

Standard Electro Clutches are offered in a wide variety of bore sizes.

UL listed

Conduit box meets industry standards.

Simple installation

Easy-to-install a pulley, sprocket, sheave or gear on the Electro Clutch shaft extension.

Long life – no maintenance

Specially designed armature disc is segmented and fluted to provide maximum cooling of friction surfaces. Automatically adjusts to wear.

No brushes to wear out

Warner Electric designed electro-magnetic circuit eliminates brushes.

Packaged Performance

The engineering is built-in. Warner Electric Packaged Performance products are factory aligned and pre-assembled. They have been designed to mate easily with industry standard motors, reducers and other power transmission components. "Bolt-it-down and wire-it-up". . . they're ready to go.

- Hubs mate to standard sheaves, sprockets, gears and pulleys
- Wide torque range from 16 to 465 lb. ft.
- Handle 1 to 20 HP at 1800 RPM

Typical Applications

Electro Clutches used for speed changing in a two speed drive.

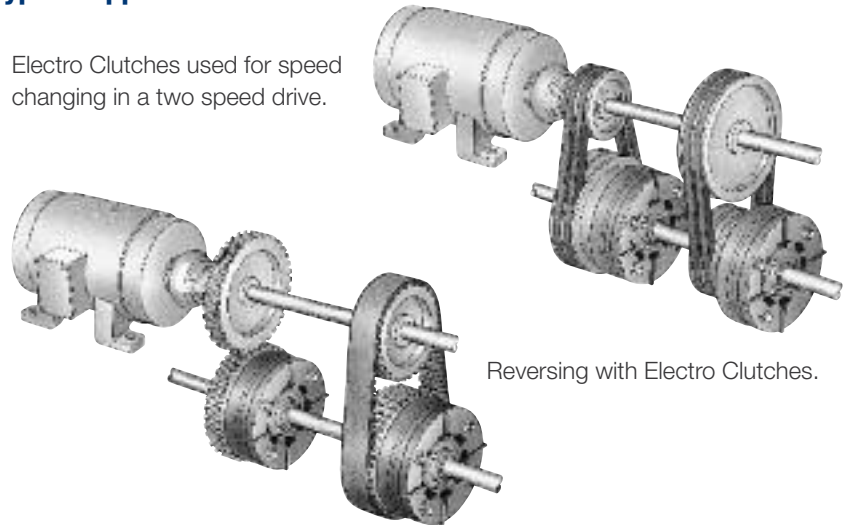

Reversing with Electro Clutches.

EC Series Electro Clutch

Selection/Ordering Information

Selection Procedure

1. Determine the motor horsepower and r.p.m. at the clutch location.
2. Use the Horsepower vs. Shaft Speed chart to determine the right size Electro Clutch.
3. When ordering, specify bore size and voltage.
4. To get maximum performance from your Electro Clutch, use a Warner Electric Control. See the Controls Section.

Note:
Electro Clutches require extended length motor shafts for motor mounting.

Part Numbers

Model Size	Bore Size	Voltage DC	Part No.
EC-375	1/2"	6	5180-271-006
		24	5180-271-004
		90	5180-271-009
EC-475	5/8"	6	5180-271-002
		24	5180-271-008
		90	5180-271-005
EC-475	3/4"	6	5181-271-033
		24	5181-271-037
		90	5181-271-036
EC-475	7/8"	6	5181-271-032
		24	5181-271-038
		90	5181-271-034
EC-650	1"	6	5181-271-031
		24	5181-271-039
		90	5181-271-035
EC-650	1-1/8"	6	5281-271-004
		24	5281-271-018
		90	5281-271-007
EC-650	1-1/4"	6	5281-271-002
		24	5281-271-019
		90	5281-271-005
EC-650	1-3/8"	6	5281-271-009
		24	5281-271-020
		90	5281-271-008
EC-825	1-1/8"	6	5281-271-003
		24	5281-271-016
		90	5281-271-006
EC-825	1-1/4"	6	5282-271-002
		24	5282-271-008
		90	5282-271-011
EC-825	1-3/8"	6	5282-271-003
		24	5282-271-009
		90	5282-271-012
EC-1000	1-3/8"	6	5282-271-004
		24	5282-271-010
		90	5282-271-013
EC-1000	1-1/2"	6	5283-271-002
		24	5283-271-010
		90	5283-271-003
EC-1000	1-5/8"	6	5283-271-012
		24	5283-271-013
		90	5283-271-013
EC-1225	1-5/8"	6	5283-271-004
		24	5283-271-011
		90	5283-271-005
EC-1225	2-1/8"	6	5284-271-008
		24	5284-271-013
		90	5284-271-010
EC-1225	1-7/8"	6	5284-271-002
		24	5284-271-014
		90	5284-271-003
EC-1225	2-1/8"	6	5284-271-004
		24	5284-271-015
		90	5284-271-005

Note: Metric bores available in some sizes, consult factory.

Horsepower vs. Shaft Speed

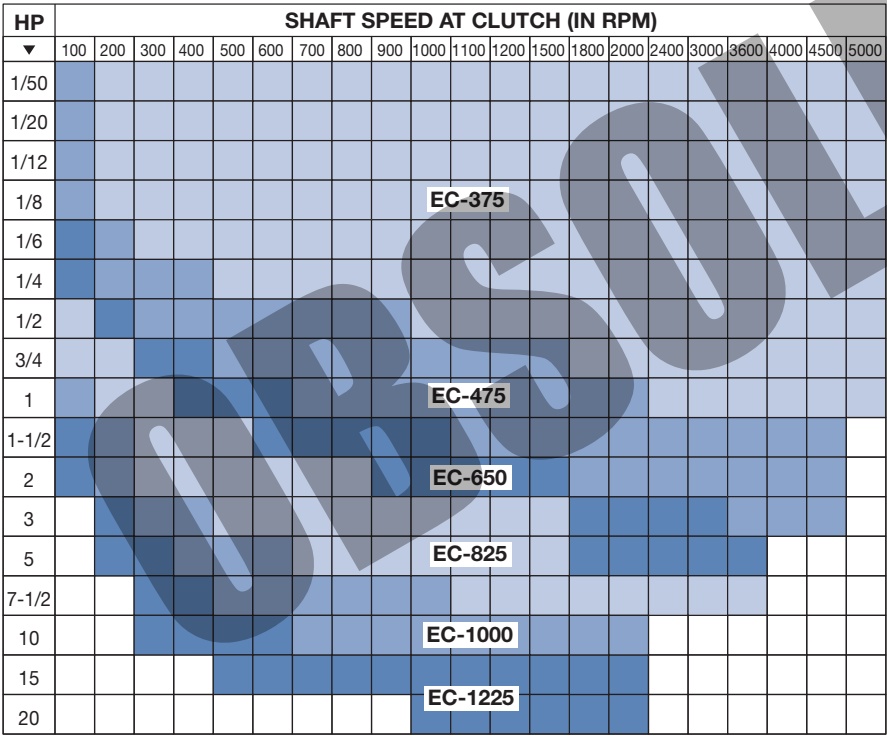

Specifications

Electro Clutch Size	Static Torque lb. ft.	Max. RPM	Voltage DC	Total Wt. lbs.
EC-375	16	5000	6, 24 or 90	4
EC-475	30	4500	6, 24 or 90	8
EC-650	95	3600	6, 24 or 90	18
EC-825	125	3600	6, 24 or 90	28
EC-1000	240	2000	6, 24 or 90	41
EC-1225	465	2000	6, 24 or 90	85

EC Series Electro Clutch

EC-375, EC-475, EC-650

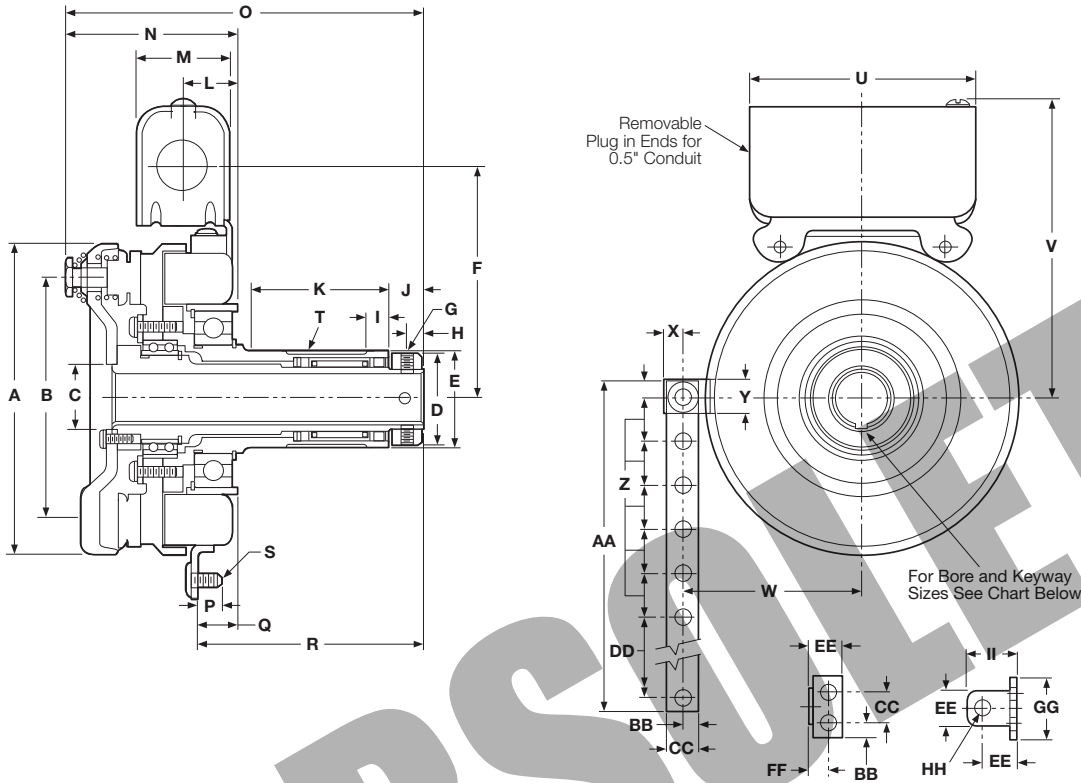

Dimensions

All dimensions are nominal, unless otherwise noted.

Size	A Max.	B Dia.	C Min.	D Dia.	E Dia.	F	G	H	I	J	K Max.	L	M
375	4.078	3.125	.7505	1.313	1.375	3.344	10-24 UNC	.188	.375	.344	2.047	.781	1.547
					1.374		-3A x 5/15						
475	5.172	4.000	1.0625	1.563	1.625	3.922	1/4-20 UNC	.281	.375	.578	2.359	.875	1.547
					1.624		-3A x 7/16						
650	6.578	5.125	1.625	2.375	2.5000	4.625	1/4-20 UNC	.281	.188	.563	3.047	.953	1.547
					2.4985		-3A x 1/2						

Bore Sizes and Keyways

Size	Bore Dia.	Keyway
375	.625	*3/16 x 1/16
	.500	1/8 x 1/16
475	.750	3/16 x 3/32
	.875	*3/16 x 1/16
	.625	3/16 x 3/32
650	1.125	*1/4 x 1/8
	1.375	*5/16 x 3/32
	1.000	1/4 x 1/8
	1.250	1/4 x 1/8

*Key Furnished

Size	N Max.	O Max.	P	Q Max.	R Min.	S	T	U	V Max.	W	X
375	2.484	4.984	.438	.609	3.000	1/4-20 UNC-2A	5/16 x 3/32	3.750	4.438	2.438	.313
475	3.219	6.266	.422	.658	3.641	1/4-20 UNC-2A	3/8 x 3/32	3.750	4.984	2.984	.313
650	3.547	7.141	.422	.722	4.359	1/4-20 UNC-2A	5/8 x 3/32	3.750	5.750	3.750	.313

Size	Y	Z	AA	BB	CC	DD	EE Dia.	FF	GG	HH Dia.	II
375	.563	.750	5.000	.250	.500	.750	.563	.313	1.000	.270 .260	.828
475	.578	.750	5.000	.250	.500	.750	.563	.313	1.000	.270 .260	.828
650	.563	.750	10.000	.250	.500	5.750	.563	.313	1.000	.270 .260	.828

Specifications

Size	Average Wt.-lbs.				Inertia-WR ² (lb.ft. ²)			
	Arm. & Carrier	Rotor	Outer Sleeve	Inner Sleeve	Arm. & Carrier	Rotor	Outer Sleeve	Inner Sleeve
EC-375	.60	.55	.49	.60	.010	.018	.001	.001
EC-475	1.13	1.12	.78	1.22	.072	.033	.006	.002
EC-650	2.3	2.5	1.6	2.37	.106	.202	.010	.013

EC Series Electro Clutch

EC-825

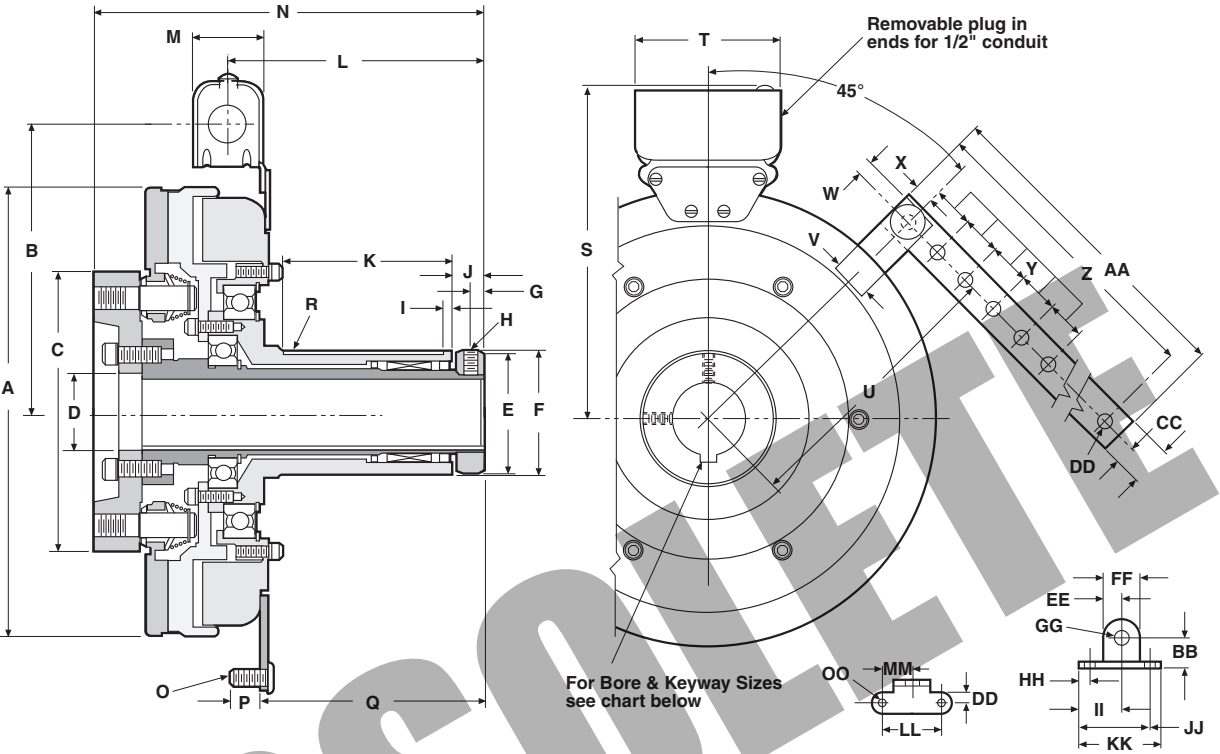

Dimensions

All dimensions are nominal, unless otherwise noted.

Size	A Max.	B Dia.	C	D Min.	E Dia.	F Dia.	G	H	I	J
825	8.656	5.656	4.625	1.437	2.375	2.5000 2.4985	.281	1/4-20 UNC -3A x 3/8	.188	.563

Size	K Max.	L	M	N Max.	O	P	Q Max.	R*	S	T
825	3.047	5.219	1.547	8.000	5/16-18 UNC-2A	1.547	4.468	5/8 x 3/32	6.813	3.750

Size	U	V	W	X	Y	Z	AA	BB	CC	DD Dia.
825	5.063	.875	—	.375	.750	16.625	17	.750	.375	.330 .321

Size	EE	FF	GG Dia.	HH	II	JJ	KK	LL	MM	NN	OO
825	.438	.875	.313	.250	1.000	1.750	2.000	1.500	.750	.250	.270 .260

* Key supplied

Specifications

Model Size	Voltage DC	Inertia-WR ² (lb. ft ²)		Total Weight lbs.	Average Weight-lbs.	
		Armature, Hub & Inner Sleeve	Rotor & Outer Sleeve		Armature, Hub & Inner Sleeve	Rotor & Outer Sleeve
EC-825	6	.35	.87	28	6.0	18.5
	24	.35	.87	28	6.0	18.5
	90	.35	.87	28	6.0	18.5

Bore Sizes and Keyways

Size	Bore Dia.	Keyway
825	1.125	1/4 x 1/8
	1.250	1/4 x 1/8
	1.375	5/16 x 3/32

EC Series Electro Clutch

EC-1000, EC-1225

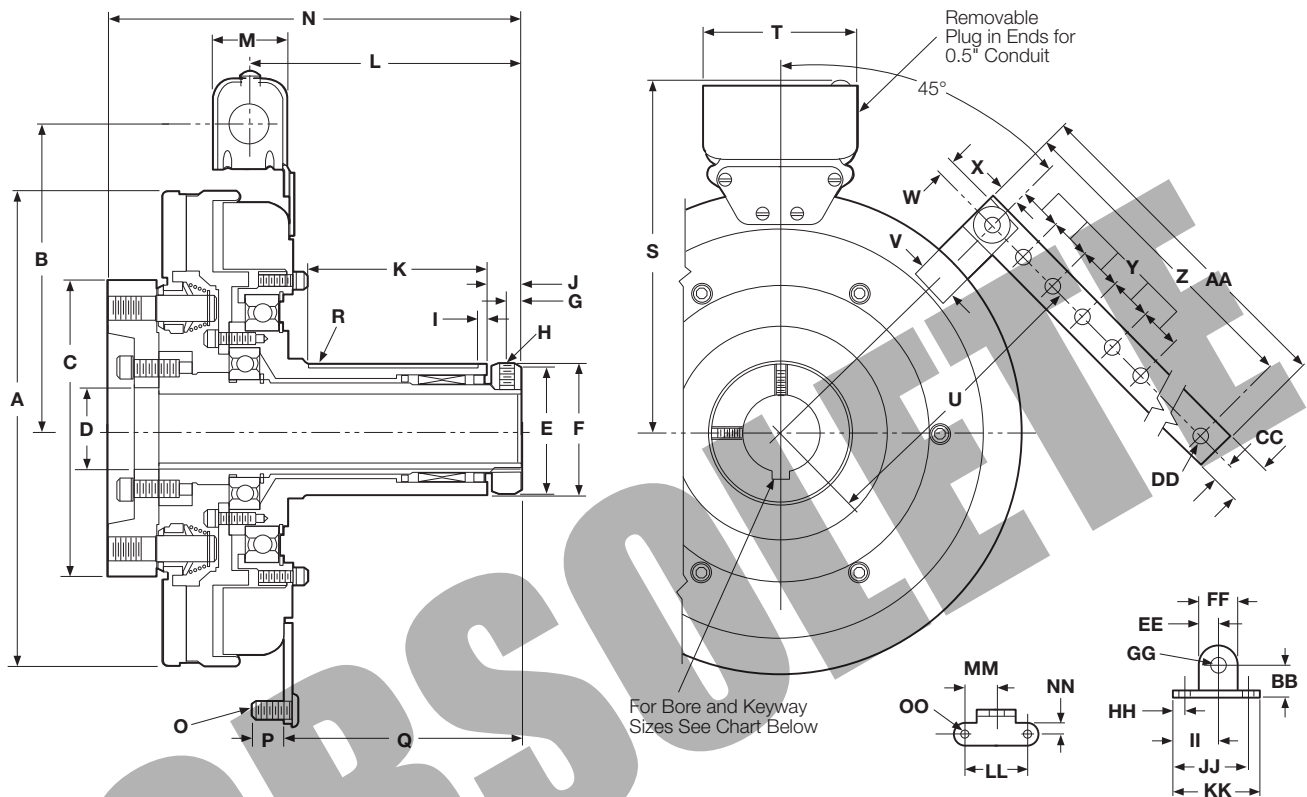

Specifications

Model Size	Voltage DC	Static Torque (lb. ft.)	Max. Speed RPM	Inertia-WR ² (lb. ft. ²)				Total Weight lbs.
				Arm. & Hub	Rotor	Outer Sleeve	Inner Sleeve	
EC-1000	6	240 lb. ft.	2000	.720	.894	.129	.036	41
	24	240 lb. ft.	2000	.720	.894	.129	.036	41
	90	240 lb. ft.	2000	.720	.894	.129	.036	41
EC-1225	6	465 lb. ft.	2000	1.8	2.4	.129	.061	85
	24	465 lb. ft.	2000	1.8	2.4	.129	.061	85
	90	465 lb. ft.	2000	1.8	2.4	.129	.061	85

EC Series Electro Clutch

EC-1000, EC-1225

Dimensions

All dimensions are nominal, unless otherwise noted.

Size	A Max.	B Dia.	C	D Min.	E Dia.	F Dia.	G	H	I	J	K Max.	L	M
1000	10.328	6.531	6.344	1.750	2.875	2.9375 2.9365	.344	5/16-18 UNC -3A x 3/8	.188	.750	3.969	6.000	1.547
1225	12.672	7.531	6.969	2.234	3.625	3.750 3.749	.406	5/81-16 UNC -3A x 3/4	.375	.859	5.219	7.781	1.547

Size	N Max.	O	P	Q Max.	R*	S	T	U	V	W	X	Y
1000	9.031	5/16-18 UNC-2A	1.547	5.281	3/4 x 1/8	7.688	3.750	6.125	.875	.344	.375	.750
1225	11.016	5/16-18 UNC-2A	1.547	7.047	7/8 x 1/8	8.688	3.750	7.000	.875	.344	.375	.750

Size	Z	AA	BB	CC	DD Dia.	EE	FF	GG Dia.	HH	II	JJ	KK	LL	MM	NN	OO
1000	16.625	17	.750	.375	.330 .321	.438	.875	.313	.250	1.000	1.750	2.000	1.500	.750	.250	.270 .260
1225	16.625	17	.750	.375	.330 .321	.438	.875	.313	.250	1.000	1.750	2.000	1.500	.750	.250	.270 .260

* Key supplied

Bore Sizes and Keyway

Size	Bore Dia.	Keyway
1000	1.375	*5/16 x 5/32
	1.500	*3/8 x 11/64
	1.625	*3/8 x 1/8
1225	1.625	*3/8 x 5/32
	1.875	*1/2 x 1/4
	2.125	*1/2 x 3/16

*Key Furnished

EB Series Electro Brake

Shaft Mounted Brakes for Power-On Applications

Pre-engineered, pre-packaged brakes mount on motor or thru shafts. They have been designed to mate easily with industry standard motors, reducers and other power transmission components. Bolt-it-down and wire-it-up . . . they're ready to go.

- Wide torque range from 16 to 465 lb. ft.
- Handle 1 to 75 HP at 1800 RPM
- Adjustable torque arm

Mounting Flexibility

Torque arm allows mounting anywhere on shaft. Standard bushings cover a wide range of shaft sizes.

UL Listed

Conduit box meets industry standards.

Long Life, No Maintenance

Automatically adjusts for wear. Designed for maximum heat dissipation. No lubrication necessary.

Packaged Design

No assembly required. Insert bushing for proper shaft size, slide on shaft and bolt down torque arm.

Typical Application

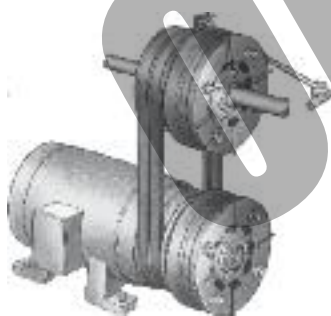

An Electro Brake mounted on a through shaft.

Horsepower vs. Shaft Speed

HP	SHAFT SPEED AT BRAKE (IN RPM)																				
	100	200	300	400	500	600	700	800	900	1000	1100	1200	1500	1800	2000	2400	3000	3600	4000	4500	5000
1/12																					
1/8																					
1/6																					
1/4																					
1/3																					
1/2																					
3/4																					
1																					
1-1/2																					
2																					
3																					
5																					
7-1/2																					
10																					
15																					
20																					
25																					
30																					
40																					
50																					
60																					
75																					

Selection/Ordering Information

Part Numbers

For Electro Brakes specifying a bushing, they need to be ordered separately. Please find specific bushing part numbers on pages 198 and 199 corresponding to the type of bushing indicated below and the required bore size.

Model Size	Bore Size or Bore Range & Bushing	Voltage DC	Part No.
EB-375	1/2"	6	5380-170-005
		24	5380-170-006
		90	5380-170-004
	5/8"	6	5380-170-003
		24	5380-170-007
		90	5380-170-002
	3/4"	6	5370-170-013
		24	5370-170-014
		90	5370-170-012
EB-475	1/2" to 1" Dodge 1008	6	5381-170-003
		24	5381-170-004
		90	5381-170-002
EB-650	1/2" to 1-3/8" Dodge 1310	6	5382-170-003
		24	5382-170-005
		90	5382-170-002
EB-825	1/2" to 1-1/2" Browning H	6	5383-170-002
		24	5383-170-004
		90	5383-170-005
EB-1000	1/2" to 1-5/8" Dodge 1615	6	5384-170-003
		24	5384-170-005
		90	5384-170-002
EB-1225	1/2" to 2-1/2" Dodge 2517	6	5385-170-003
		24	5385-170-005
		90	5385-170-002

Note: EB-375 also available in some metric bores.
EB-475-1225 use bushings which are available in metric bores.

Bore Sizes and Keyway

Size	Bore Dia.	Keyway
375	.501/.500	1/8 x 1/16
	.626/.625	3/16 x 3/32
	.751/.750	3/16 X 3/32
475 Through 1225	See bushing information on pages 198-199	

For Service Parts:

See pages 276-281.

For Motor Mounting:

See page 79 for adapter requirements.

EB Series Electro Brake

EB-375, EB-475, EB-650

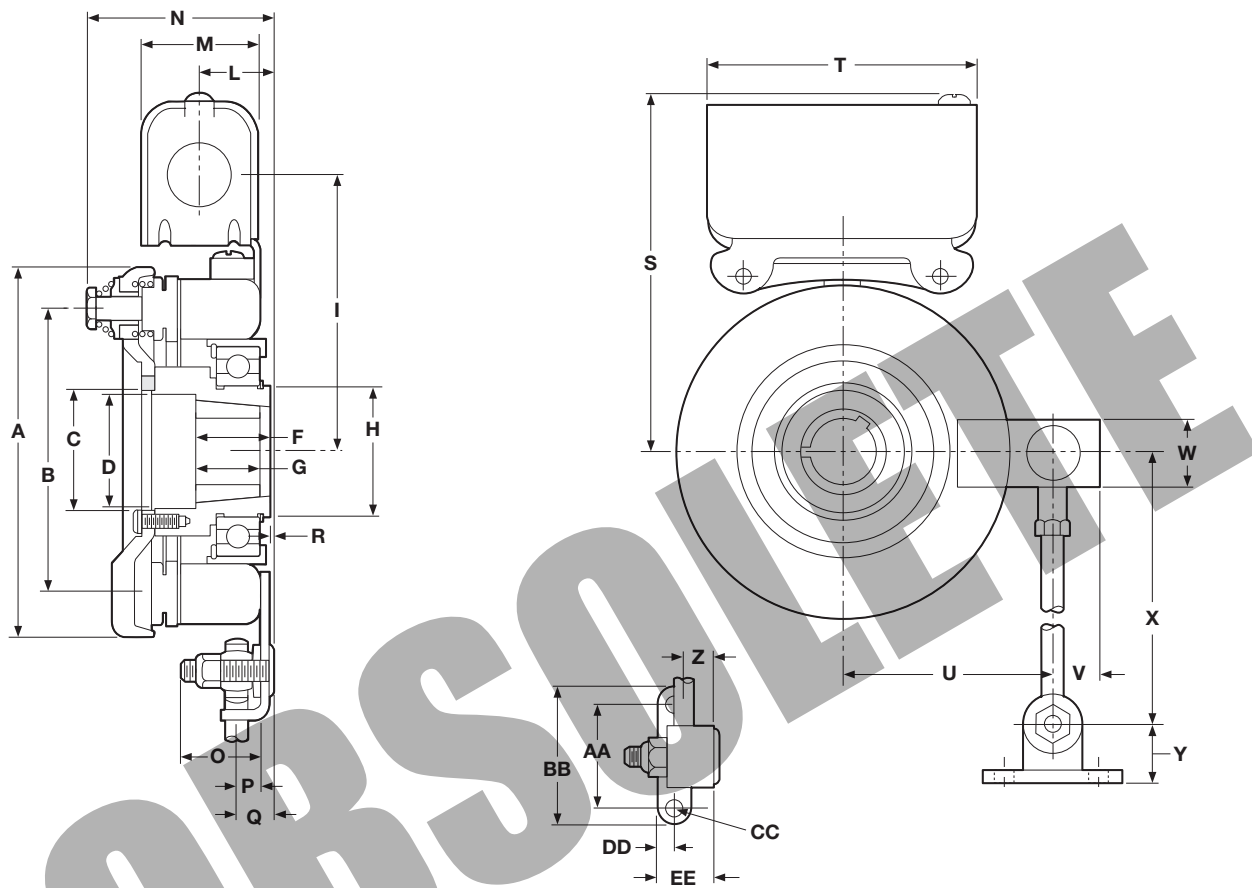

Dimensions

All dimensions are nominal, unless otherwise noted.

Size	A Max.	B Dia.	C Min.	D Dia.	E	F	G	H Dia.	I	J	K	L	M	N Max.	O
375	4.078	3.125	.7505	-	.031	1.656	-	1.375	3.344	10-32 UNF -3A x 1/4	.188	1.047	1.547	2.438	.844
475	5.172	4.000	1.663	1.594	-	1.000	1.000	1.781	3.875	-	-	.986	1.547	2.922	1.094
650	6.578	5.125	2.343	2.281	-	1.313	1.000	2.563	4.656	-	-	.986	1.547	3.109	1.031

Size	P	Q	R	S Max.	T	U	V	W	X	Y	Z	AA	BB	CC	DD	EE
375	.281	.625	.094 Min.	4.453	3.750	2.453	.666	1.000	8.000	.635	.359	1.500	2.000	.270 .260	.250	.781
475	.313	.531	.125 Max.	4.984	3.750	3.093	.697	1.000	10.000	.635	.391	1.500	2.000	.270 .260	.250	.781
650	.344	.641	.203 Max.	5.766	3.750	4.063	.843	1.125	11.000	.635	.438	1.500	2.000	.270 .260	.250	.781

Specifications

Model Size	Voltage DC	Static Torque (lb. ft.)	Max. Speed RPM	Inertia-WR ² (lb. ft ²)		Total Weight lbs.
				Arm. & Carrier	Hub	
EB-375	6, 24, 90	16	5000	.010	.001	4
EB-475	6, 24, 90	30	4500	.072	.006	7
EB-650	6, 24, 90	95	3600	.106	.010	11.3

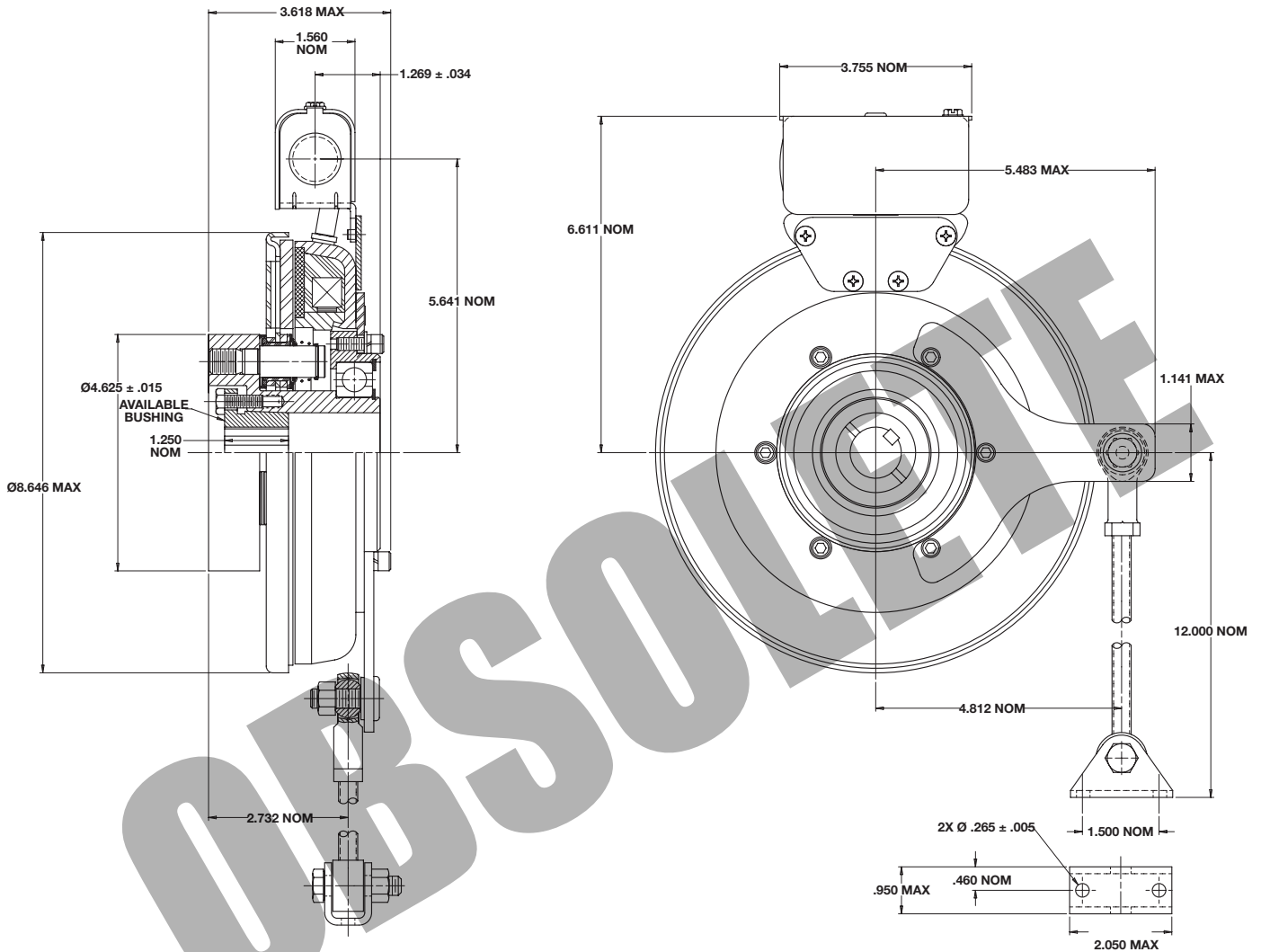

Specifications

Model Size	Voltage DC	Static Torque lb. ft.	Max. Speed RPM	Inertia-WR ² (lb. ft ²) Arm. & Hub	Total Weight lbs.
EB-825	6, 24, 90	125	3600	.459	20

EB Series Electro Brake

EB-1000, EB-1225

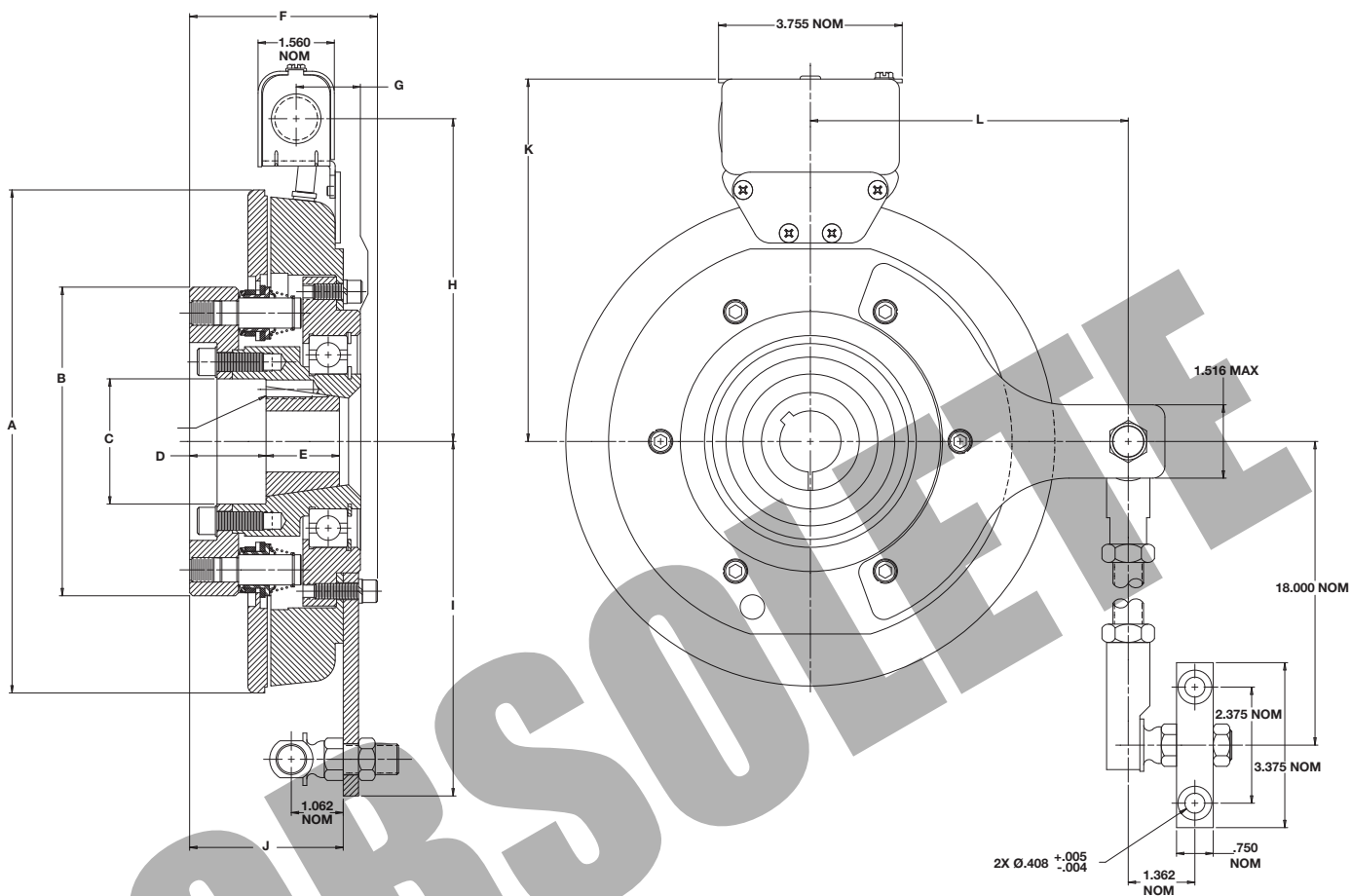

For thru-shaft mounting, specify bore size. Order bushing separately.
 For motor mounting, order adapter separate (see page 79).

Dimensions

All dimensions are nominal, unless otherwise noted.

Size	A Max.	B Max.	C Min.	D	E	F Max.	G	H	I	J	K	L
1000	10.318	6.328	2.558	1.563	1.500	3.891	1.308	6.515	7.265	3.141	7.411	6.500
1225	12.703	6.953	3.390	.875	1.750	4.082	1.176	7.620	8.000	3.322	8.481	7.250

Specifications

Model Size	Voltage DC	Static Torque lb. ft.	Max. Speed RPM	Inertia-WR ² (lb. ft ²)		Total Weight lbs.
				Arm. & Hub	Hub	
EB-1000	6, 24, 90	240	2000	.720	.129	35.5
EB-1225	6, 24, 90	465	2000	1.8	.129	52.5

Optional Motor Shaft Adapter

Ten motor shaft adapters are available as an option for mounting Electro-Brakes on single shaft extension motors. For double shaft extension motors the adapter can be eliminated. A standard sheave, pulley, or sprocket, with either a tapered bushing or straight bore, can be installed on the shaft adapter. The Electro Brake is mounted on the end of the shaft adapter and the complete assembly fits onto the motor shaft and is secured with setscrews. Fitting the belts or chain and attaching the torque arm completes the installation.

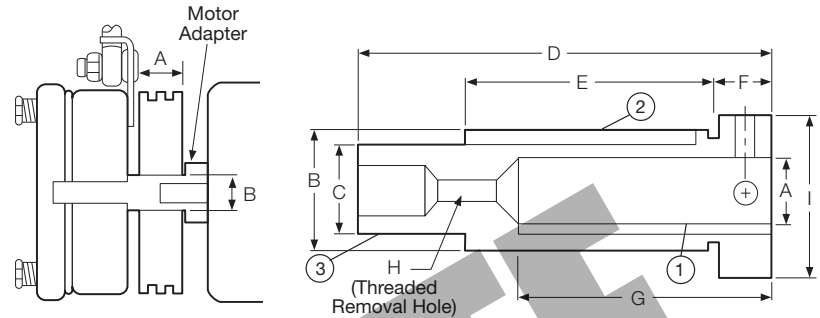

Dimensions

All dimensions are nominal, unless otherwise noted.

Model	A	Kwy.	Key Part No. ①	B	Kwy.	Key Part No. ②	C	Kwy.	Key Part No. ③	Dodge Bushing Size	D	E	F	G	H	I
EB-375	5/8	3/16x 3/32	*	7/8	3/16x 3/32	590-0016	5/8	3/16x 3/32	590-0043	None	4.391 4.359	2	.391 .359	2	1/4-20 UNC	1.125
EB-375	7/8	3/16x 3/32	*	1-1/4	1/4x 1/8	590-0022	5/8	3/16x 3/32	590-0043	None	4.578 4.742	2-1/4	.516 .484	2-1/4		1.500
EB-475	1-1/8	1/4x 1/8	*	1-5/8	3/8x 3/16	590-0041	1	1/4x 1/8	**	#1008 1"	4.516 4.484	2-3/4	.641 .609	2-3/4	1/2-13 UNC	1.750
EB-650	1-3/8	5/16x 5/32	*	2	1/2x 1/4	590-0042	1-3/8	5/16x 5/32	590-0044	#1310 1-3/8"	5.547 5.515	3-3/8	.641 .609	3-3/8	1/2-13 UNC	2.125
EB-650	1-5/8	3/8x 3/16	*	2-1/4	1/2x 1/4	590-0042	1-3/8	5/16x 5/32	590-0044	#1310 1-3/8"	6.172 6.140	4	.641 .609	4		2.375
EB-1000	1-5/8	3/8x 3/16	*	2-15/16	3/4x 7/16	590-0052	1-5/8	3/8x 7/32	**	#1615 1-5/8"	8.297 8.265	5-1/4		5	3/4-10 UNC	2.937
EB-1000	1-7/8	1/2x 7/32	*	2-15/16	3/4x 7/16	590-0052	1-5/8	3/8x 7/32	**	#1615 1-5/8"						2.937
EB-1000	2-1/8	1/2x 1/8	590-0062	2-15/16	3/4x 5/16	590-0069	1-5/8	3/8x 7/32	**	#1615 1-5/8"						2.937
EB-1225	2-1/8	1/2x 7/32	*	3-3/4	7/8x 7/16	590-0049	2-1/8	1/2x 9/32	590-0048	#2517 2-1/8"	10.672 10.640	7-1/4		6-7/8	7/8-9 UNC	3.750
EB-1225	2-3/8	5/8x 9/32	*	3-3/4	7/8x 7/16	590-0049	2-1/8	1/2x 9/32	590-0048	#2517 2-1/8"						3.750

*Standard Square Key Furnished with Motor.

**Special Key Furnished with Bushing.

Note: For adapter part numbers, see Service Parts beginning on page 276.

ATC / ATB Series AT Clutches and Brakes

Rugged, Durable, Heavy Duty Clutches and Brakes

Warner Electric's AT clutches and brakes are rugged and durable.

The ATC and ATB incorporate a molded friction material/pole assembly and replaceable armature faces with a rugged, durable clutch and brake assembly. Uniquely designed for ease of application and low maintenance.

Besides providing the ultimate in long life and durability, the AT units are easily repairable. Mounting a standard sheave, pulley or sprocket to the clutch is a snap.

The AT Clutches and Brakes feature a replaceable friction face. The results are long life, efficient operation, and minimal down time. Service kits of pre-selected parts enhance unit life.

ATC's and ATB's are completely assembled at the factory and have been specifically designed to match the torque ratings of standard motors, reducers, and other power transmission components. Easy-to-select and easy-to-install.

AT Clutches and Brakes are ideally suited for extremely rugged, heavy duty application demands.



Advanced Technology Design Advantages

- Replaceable friction face
- Steel wear surface and cast iron hub/armature carrier
- Non-asbestos, split molded friction disc.
- Autogap™ provides automatic wear take-up for consistent engagement.
- Cast iron components—finned, cast iron armature carriers
- Special coil design for high temperature operation.
- Sealed heavy duty bearings
- Rugged spline drive operation
- Easy to install
- Maintenance free

Options and Accessories

Warner Electric offers accessories and repair kits for AT clutches and brakes, including:

- Clutch field restraining straps
- Brake torque arms
- Conduit boxes
- Clutch pulleys
- Service kits

ATC / ATB Series AT Clutches and Brakes

Applications/Mounting Configurations

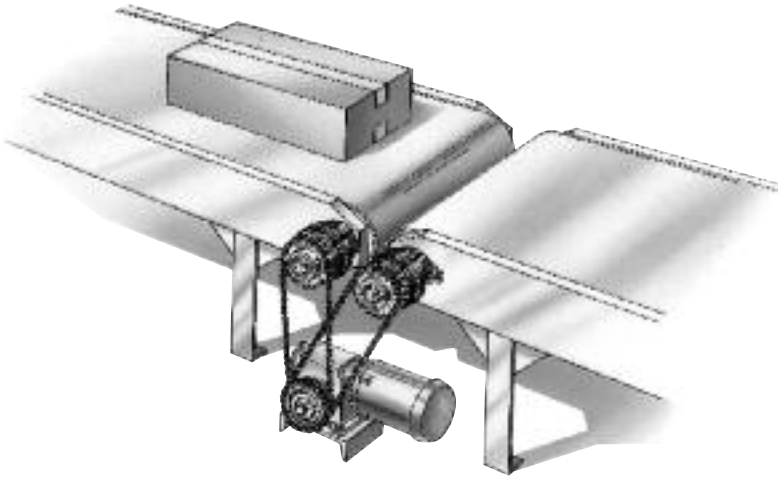

Two AT Clutches, easily mounted on conveyor headshafts, allow conveyor sections to be separately powered from a single drive.

The rugged durability of the AT Clutches and Brakes make them an obvious choice for heavy duty applications.

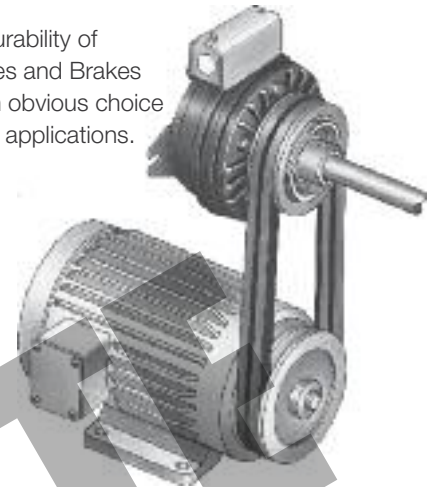

AT Clutch and AT Brake on through shaft



Shaft mounted AT Clutch

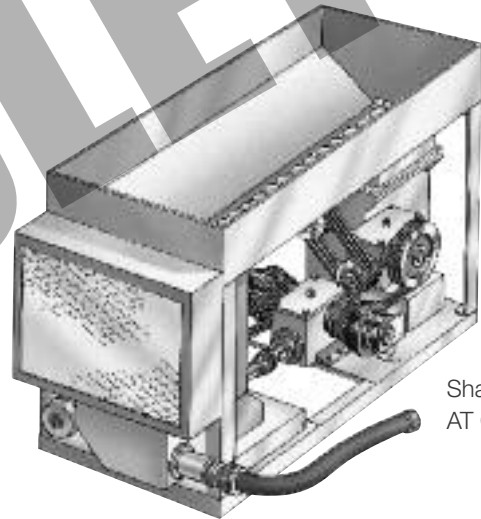

AT Clutches and Brakes are excellent for controlled torque applications.

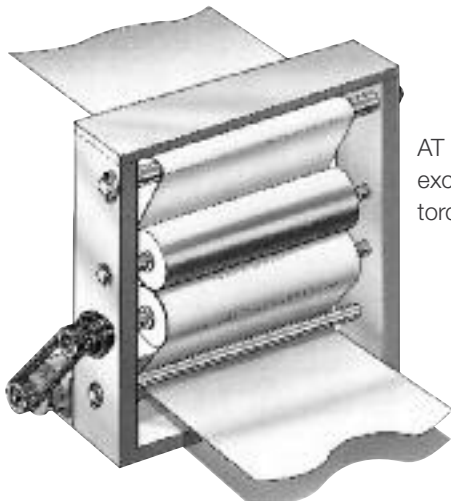

AT Clutch on motor, AT Brake on through shaft

ATC / ATB Series AT Clutches and Brakes

Performance Advantages

Principle of Operation

Ease of control is one of the most outstanding features of Warner Electric brakes and clutches. In operation, a magnetic field is generated as soon as current flows through the magnet coil. The magnetic poles are molded into a replaceable disc with the friction material. The electromagnetic force from the field or magnet passes through the poles to attract the armature, clamping the two together tightly. Strength of the magnetic field is directly proportional to the amount of current applied. The full torque range is completely controllable from 0 to 100% simply by turning the knob on the appropriate Warner Electric control.

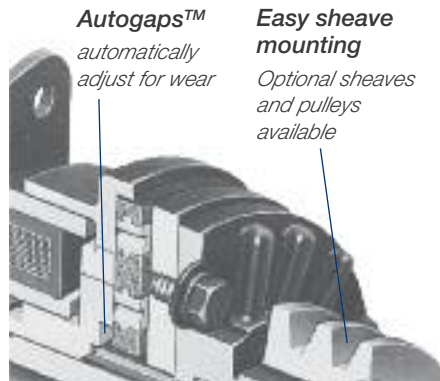

Replaceable Friction Discs

The AT Electric Clutches and Brakes feature a patented replaceable friction face incorporating a unique combination of electromagnetic poles and friction material in a simple component. Easily visible friction disc indicates when replacement is necessary—providing a helpful maintenance guide. The results are long life, efficient operation, and minimal down time. Rebuild kits of pre-selected parts enhance unit life.

The split friction disc and armature are replaceable without unit disassembly in less than 5 minutes in most applications.

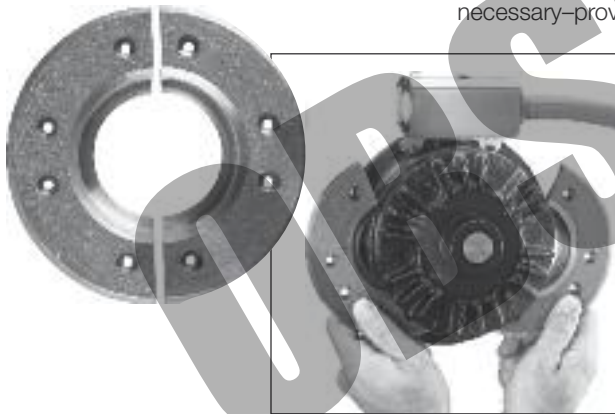

Autogap™ Alignment

Provides for automatic adjustment of the air gap between the wearing friction surfaces. Engagement times are consistent to maintain stopping and starting accuracy for the entire life of the unit.

Technical Considerations

Most normal duty applications will usually require a selection based only on horsepower and speed at the clutch or brake location as indicated on pages 83, 84 and 88. However, to insure the best possible overall performance and the most cost effective unit size selection, additional factors should be considered.

The main criteria are:

1. Horsepower
2. RPM
3. System inertia at the clutch or brake
4. Cycle rate and start/stop time
5. Static torque requirement, if any.

For instance, the HP and RPM sizing derived from the selection chart on page 84, may be different than the size required by the system inertia and cycle rate. In that case, the proper size is the larger size unit. Additional application information makes a very accurate and exacting unit size selection possible. To achieve this, system inertia and required cycle rate must be known.

Cycle Rate

Cycle rate capability is often an important selection criteria. Cycle rate is usually defined as the number of times the clutch and/or brake is switched on and off in a minute or Cycles per Minute (CPM). In order to determine the correct size unit, both required cycle rate and reflected inertia must be known. The inertia of the AT clutch/brake components has been factored into the charts, so these need not be considered. To determine size from the charts:

1. Estimate the size clutch or brake.
2. Read the chart for that size. The intersection of the reflected inertia (lb. ft.²) and speed difference (RPM) lines will indicate the maximum cycle rate for that size unit.
3. Compare cycle rates. If the cycle rate required falls within the units capability, proceed to step 4 below. If the required cycle rate is above the size selected, go to the next larger AT unit.
4. Verify selection. Compare the size selected in 2 and 3 above to the Horsepower/Speed simple selection made on page 84. If the size selected is not the same, choose the larger selected by the two methods.

Cycle Rate Capability

ATC 25/ATB 25

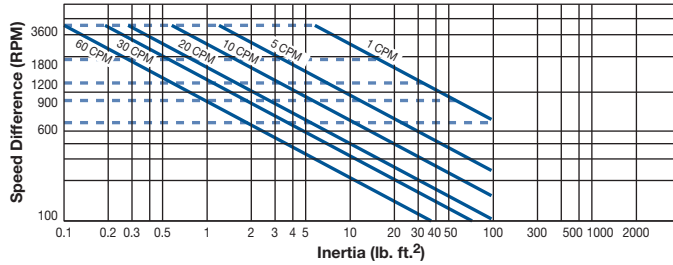

Stop/Start Time Capability

ATC 25/ATB 25

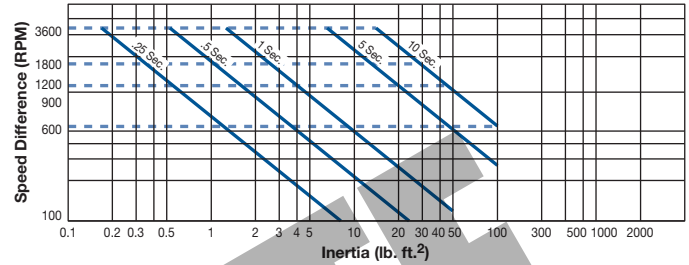

ATC 55/ATB 55

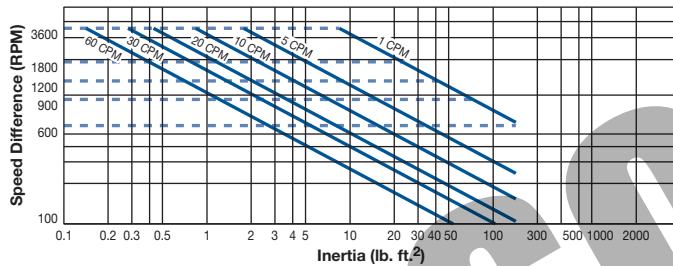

ATC 55/ATB 55

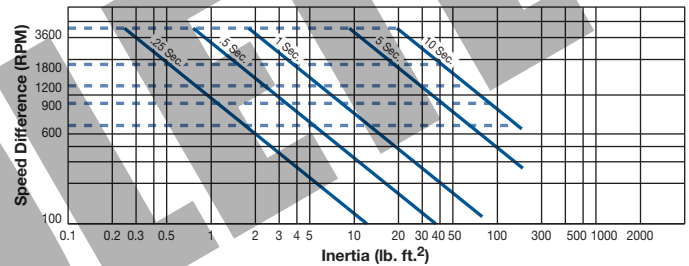

ATC 115/ATB 115

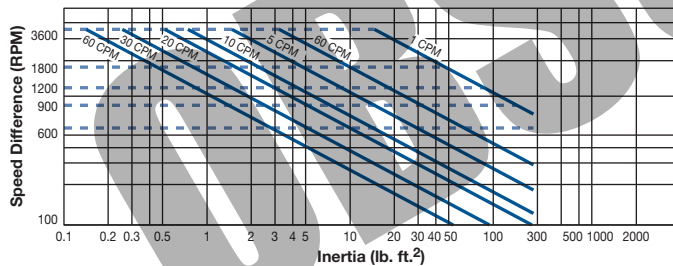

ATC 115/ATB 115

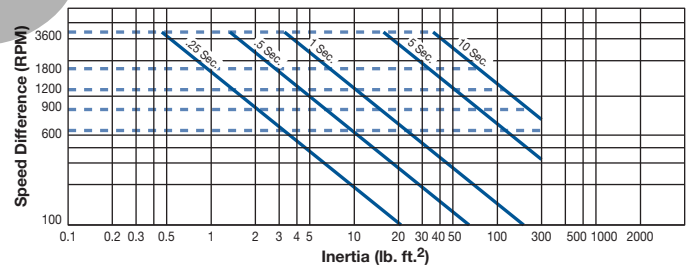

Start/Stop Times

In some applications, accelerating and/or decelerating the load within a specific time is a critical factor. In these start/stop time charts, AT unit inertias have already been factored in, so only reflected inertia need be considered. Selection for start/stop times can be made as follows:

1. Estimate the size clutch or brake required.
2. Read the chart for that size. Cross reference the speed difference (RPM) with the reflected inertia (lb. ft.²) to find the maximum start/stop capability for that size unit.
3. Compare start/stop times. If the start/stop time is equal to or less than that required for that application, the correct size unit has been selected. If shorter start/stop times are required, repeat the procedure on the chart for the next larger size unit.
4. Verify the selection. Compare the unit size chosen in steps 1, 2, and 3 to the unit size chosen by the simple Horsepower/Speed method on page 84. If the sizes selected are not identical, choose the larger selected by the two methods.

ATC Series AT Clutch

Rugged and Durable Operation

Autogaps™

automatically adjust for wear.

Rugged spline drive

for maximum durability.

Sealed, high temperature.

UL recognized.

Rugged steel wear surface

and precision cast iron components.

Easy sheave mounting.

Optional sheaves and pulleys available from Warner Electric.

Sealed heavy duty bearings

with high temperature lubricant.

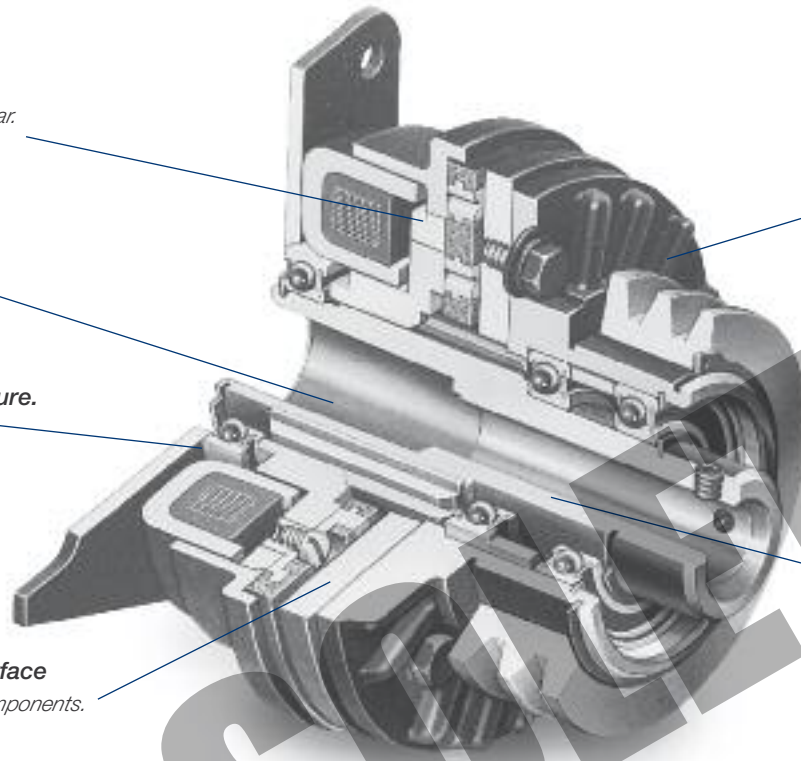

Mounting Flexibility

The ATC clutch design represents the best combination of features to allow mounting of the widest range of pulleys, sheaves or sprockets with keys and snap rings or bolts for maximum durability. The pulleys or sheaves selected as standard offerings to

support the line are matched to the torque capability of each clutch. The torques and wear lives have been designed to match industry-standard motors and reducers by shaft size and bore size.

Selection

1. Determine Model Size

Determine the motor horsepower and shaft speed (in R.P.M.) at the clutch location.

The correct size unit is shown at the intersection of HP and shaft speed.

2. Determine Bore Size

Select bore size and determine part number for correct size clutch from parts lists starting on page 85.

3. Select Options

Refer to the Standard Sheaves and Pulley chart to choose an optional Warner Electric standard pulley or obtain information for fitting other pulley or sprocket.

4. Select Control

A simple, built-in AC to DC control is optional for 90 volt AT Clutches.

Complete control information is found in the Controls Section.

Horsepower vs. Shaft Speed

HP	SHAFT SPEED (IN RPM)																		
	100	200	300	400	500	600	700	800	900	1000	1100	1200	1500	1800	2000	2400	3000	3600	
1/4																			
1/2																			
3/4																			
1											AT-25								
1-1/2																			
2																			
3																			
5											AT-55								
7-1/2											AT-115								
10																			
15																			
20																			
25																			
30																			
35																			

Selection/Ordering Information

Optional Equipment

Standard Sheaves and Pulleys

Sheave Pulley Type	Clutch or Brake Size	No. Grooves No. Teeth	Part Number	Pitch Diameter	Width	Dimensions O.D.
Timing Belt	25	26H100	689-0256	4.138"	1.312"	4.244"
	55	30H100	689-0278	4.755"	1.312"	4.881"
	115	40H150	689-0257	6.366"	1.812"	6.472"
"A" Section	25	1G3.60	689-0267	3.600"	.750"	3.850"
	55	2G4.80	689-0308	4.800"	1.445"	5.050"
	115	3G6.00	689-0271	6.000"	2.000"	6.250"
"3V" Section	25	1G3.65	689-0259	3.600"	.695"	3.650"
	55	2G4.12	689-0315	4.070"	1.094"	4.120"
	115	3G5.30	689-0263	5.250"	1.515"	5.300"
"B" Section	115	2G6.00	689-0275	6.000"	1.750"	6.350"

Other Sheaves, Pulleys and Sprockets

The unique AT Clutch design permits the installation of any customer provided sheave, pulley or sprocket that can be bored out and key seated to the Bore-to-Size dimensions shown on page 87.

Sprockets

The AT clutch design permits installation of customer supplied sprockets. Minimum size sprocket requirements found in the chart below can be bored out and drilled to the dimensions in that chart.

Part Numbers

Model Size	Bore Size	Voltage DC	Part No.
ATC-25	1/2"	6	5161-271-002
		24	5161-271-010
		90	5161-271-003
	5/8"	6	5161-271-004
		24	5161-271-011
		90	5161-271-005
	3/4"	6	5161-271-006
		24	5161-271-012
		90	5161-271-007
	7/8"	6	5161-271-008
		24	5161-271-013
		90	5161-271-009
ATC-55	3/4"	6	5162-271-002
		24	5162-271-010
		90	5162-271-003
	7/8"	6	5162-271-004
		24	5162-271-011
		90	5162-271-005
	1"	6	5162-271-006
		24	5162-271-012
		90	5162-271-007
	1-1/8"	6	5162-271-008
		24	5162-271-013
		90	5162-271-009
ATC-115	1-1/8"	6	5163-271-002
		24	5163-271-010
		90	5163-271-003
	1-1/4"	6	5163-271-004
		24	5163-271-011
		90	5163-271-005
	1-3/8"	6	5163-271-006
		24	5163-271-012
		90	5163-271-007
	1-1/2"	6	5163-271-008
		24	5163-271-013
		90	5163-271-009

Minimum Size Sprockets for Pilot Mount

Chain Size	Clutch Size		
	25	55	115
25	54T	—	—
35	35T	40T	—
41/40	28T	30T	40T
50	22T	24T	30T
60	—	20T	24T
80	—	—	20T
100	—	—	—
120	—	—	—
Bore size	2.500/2.502/ (63.500/63.551)	3.000/3.002/ (76.200/76.251)	4.00/4.002/ (101.600/101.651)
Bolt Circle	3.000/(76.200)	3.500/(88.900)	4.750/(120.650)
No. Holes and Sizes	(3) .281/[(3) 7.144]	(4) .281/[(4) 7.144]	(4) .344/[(4) 8.731]

Note: Spacer may be required to avoid chain interference with clutch.

ATC Series AT Clutch

ATC-25, ATC-55, ATC-115

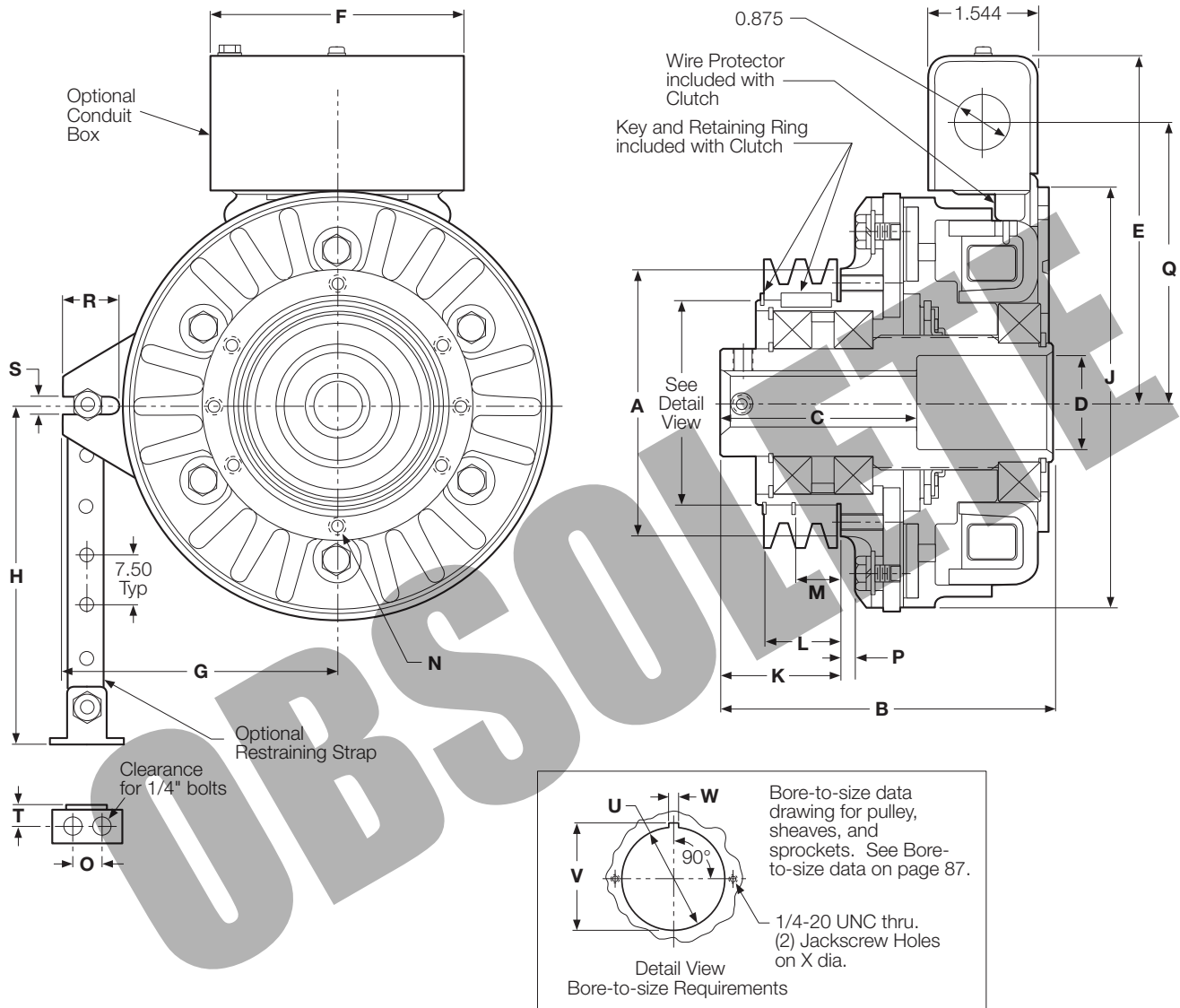

Specifications

Model Size	Voltage DC	Unit	Inertia*-WR ² (lb.ft. ²)	Max. RPM	Weight (lbs.)	Static Torque (lb.ft.)	Dynamic Torque @ 1800 RPM
25	6	Clutch	.048	3600	8	25	12 lb. ft.
	24		.048	3600	8	25	12 lb. ft.
	90		.048	3600	8	25	12 lb. ft.
55	6	Clutch	.173	3600	18	55	20 lb. ft.
	24		.173	3600	18	55	20 lb. ft.
	90		.173	3600	18	55	20 lb. ft.
115	6	Clutch	.483	3600	28	115	30 lb. ft.
	24		.483	3600	28	115	30 lb. ft.
	90		.483	3600	28	115	30 lb. ft.

ATC Series AT Clutch

ATC-25, ATC-55, ATC115

Dimensions

All dimensions are nominal, unless otherwise noted.

Model	A Max. Dia.	B Max.	C Nom.	D Nom. Dia.	E Max.	F Max.	G Max.	H Max.	J Max. Dia.	K Max.	L Nom.	M Max.	T Nom.
25	3.60 (91.44)	4.39 (111.51)	2.375 (60.33)	1.080 (27.43)	4.748 (120.60)	3.767 (95.68)	3.282 (83.36)	5.11 (129.79)	4.822 (122.49)	1.68 (42.67)	1.003/.991 (25.48/25.17)	.715/.703 (18.16/17.86)	.375 (9.53)
55	3.95 (100.33)	4.935 (125.35)	2.925 (74.30)	1.40 (35.56)	5.182 (131.62)	3.767 (95.682)	4.032 (102.412)	5.11 (129.792)	6.275 (159.39)	1.817 (46.152)	1.113/1.101 (28.27/27.97)	-	.375 (9.53)
115	5.254 (133.452)	5.977 (151.822)	3.102 (78.792)	1.86 (47.242)	6.089 (154.662)	3.767 (95.682)	4.246 (107.852)	10.11 (256.792)	7.906 (200.812)	2.467 (62.662)	1.539/1.523 (39.09/38.68)	-	.375 (9.53)

Model	No. of Holes	N Thread Size	Max. Depth	Bolt Circle	O Nom.	P Nom.	Q Nom.	R Min.	S Min.
25	3	1/4-20	.500	3.00	.500 (12.7)	.036 (0.91)	3.586 (91.10)	.752 (19.08)	.279 (7.09)
55	4	1/4-20	.635	3.50	.500 (12.7)	.081 (2.06)	4.156 (105.56)	.722 (18.34)	.265 (6.73)
115	4	5/16-18	.830	4.75	.500 (12.7)	.237 (6.02)	4.927 (125.15)	.504 (12.80)	.265 (6.73)

Bore to Size Data

Model	U Bore Dia.	V Keyway Height	W Keyway Width	X Bolt Circle
25	2.502/2.500 (63.55/63.50)	2.601/2.591 (66.06/65.81)	.1905/.1855 (4.84/4.79)	3.00 (76.20)
55	3.002/3.000 (76.25/76.20)	3.099/3.089 (78.71/78.46)	.1905/.1885 (4.84/4.79)	3.50 (88.90)
115	4.002/4.000 (101.65/101.60)	4.127/4.117 (104.83/104.57)	.378/.376 (9.60/9.55)	4.50 (114.30)

Bore Size and Keyways

Size	Unit Bore		Key
	(in.)	(mm)	
ATC-25	.5025	12.76	1/8 Sq.
	.5005	12.71	
	.6275	15.94	3/16 Sq.
	.6255	15.89	
ATC-25	.7525	19.11	3/16 Sq.
ATC-55	.7505	19.06	
ATC-25	.8775	22.29	3/16 Sq.
ATC-55	.8755	22.24	
ATC-55	1.0025	25.46	1/4 Sq.
ATC-55	1.0005	25.41	
ATC-55	1.1275	28.64	1/4 Sq.
ATC-115	1.1255	28.59	
ATC-115	1.2525	31.81	1/4 Sq.
	1.2505	31.76	
	1.3775	34.99	5/16 Sq.
	1.3755	34.94	
	ATC-115	1.5025	38.16
ATC-115	1.5005	38.11	

ATB Series AT Brake

Replaceable Armature Faces Assure Minimum Downtime

Rugged, two piece replaceable steel wear surface and precision cast iron components. Superior wear life, torque capacity and magnetic characteristics.

Two piece molded friction disc replaceable without disassembly of unit in most applications. Long life, low noise.

Sealed heavy duty bearing with high temperature lubricant maintain tight concentricities and running efficiency.

Sealed, high temperature coil with tough teflon lead wires for easy power hookup. UL recognized.

Rugged spline drive

Autogaps™ automatically adjust for wear. Consistent engagement times and repeatability for the life of the unit.

Shaft mounted with torque arm restraint.

ATB Brakes are completely assembled at the factory and have been specifically designed to match the torque ratings of standard motors, reducers, and other power transmission components. They feature a replaceable friction face, which has been designed to provide superior wear life with reduced engagement noise level wear and consistent torque capacity. Wear surfaces can, in many cases, be replaced without removing the unit from the shaft.

4. Select Control

A simple, built-in AC to DC control is optional for 90 volt AT Brakes.

Complete control information is found in the Controls Section. Selection is by required function.

Ordering Information

Part Numbers

Model Size	Bore Size	Voltage DC	Part No.
ATB-25	1/2"	6	5191-170-002
		24	5191-170-010
		90	5191-170-003
	5/8"	6	5191-170-004
		24	5191-170-011
		90	5191-170-005
	3/4"	6	5191-170-006
		24	5191-170-012
		90	5191-170-007
7/8"	6	5191-170-008	
	24	5191-170-013	
	90	5191-170-009	
ATB-55	3/4"	6	5192-170-002
		24	5192-170-010
		90	5192-170-003
	7/8"	6	5192-170-004
		24	5192-170-011
		90	5192-170-005
	1"	6	5192-170-006
		24	5192-170-012
		90	5192-170-007
1-1/8"	6	5192-170-008	
	24	5192-170-013	
	90	5192-170-009	
ATB-115	1-1/8"	6	5193-170-002
		24	5193-170-010
		90	5193-170-003
	1-1/4"	6	5193-170-004
		24	5193-170-011
1-3/8"	6	5193-170-005	
	24	5193-170-012	
	90	5193-170-007	
1-1/2"	6	5193-170-008	
	24	5193-170-013	
	90	5193-170-009	

Horsepower vs. Shaft Speed

HP	SHAFT SPEED (IN RPM)																		
	100	200	300	400	500	600	700	800	900	1000	1100	1200	1500	1800	2000	2400	3000	3600	
1/4																			
1/2																			
3/4																			
1											AT-25								
1-1/2																			
2																			
3																			
5											AT-55								
7-1/2												AT-115							
10																			
15																			
20																			
25																			
30																			
35																			

ATB Series AT Brake

ATB-25, ATB-55, ATB-115

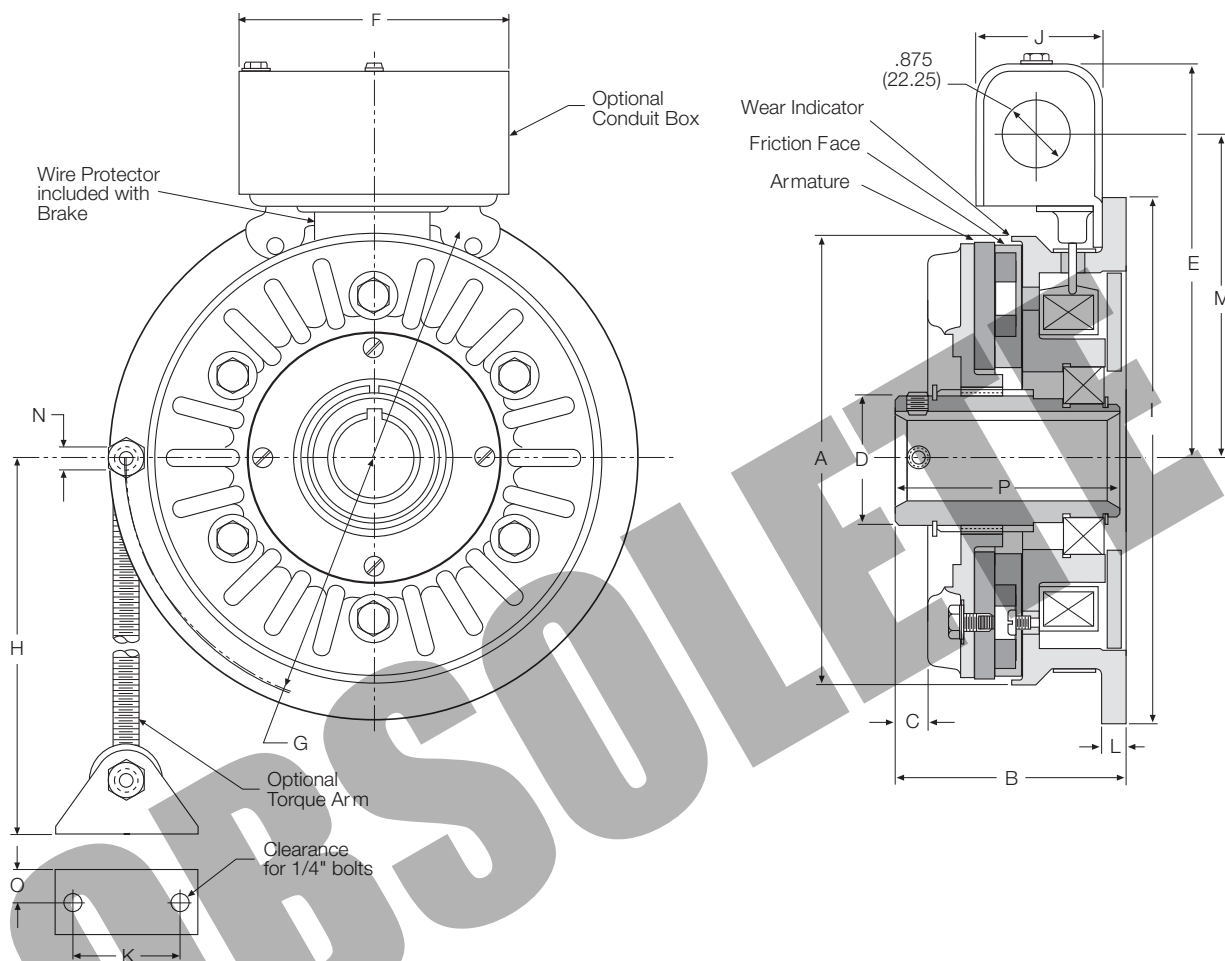

Dimensions

All dimensions are nominal, unless otherwise noted.

Model	A Max. Dia.	B Max.	C Min. Dia.	D Max.	E Nom.	F Max.	G Nom.	H Max.
25	4.822 (122.48)	2.843 (72.21)	.354 (8.99)	1.345 (34.16)	4.748 (120.60)	3.767 (95.68)	2.406 (61.11)	9.03 (229.36)
55	6.271 (159.28)	3.224 (91.89)	.281 (7.14)	1.756 (44.83)	5.37 (136.40)	3.767 (95.68)	3.00 (76.20)	11.19 (284.23)
115	7.906 (200.81)	4.115 (104.52)	.687 (17.45)	2.150 (54.61)	6.278 (159.46)	3.767 (95.68)	3.781 (96.04)	11.19 (284.23)

Model	I Max. Dia.	J Nom.	K Min. Nom.	L Max.	M Nom.	N Min.	O Nom.	P Max.
25	5.760 (146.30)	1.544 (39.22)	1.500 (38.10)	.195 (4.95)	3.586 (91.08)	.280 (7.11)	.312 (7.92)	2.765 (70.23)
55	7.375 (187.33)	1.544 (39.22)	1.50 (38.10)	.491 (12.47)	4.208 (106.88)	.375 (9.53)	.375 (9.53)	3.105 (78.87)
115	9.00 (228.60)	1.544 (39.22)	1.50 (38.10)	.463 (11.76)	5.116 (129.95)	.375 (9.53)	.375 (9.53)	3.955 (100.46)

Bore Sizes and Keyways

Size	Unit Bore	Key
ATB-25	.5025	12.76
	.5005	12.71
	.6275	15.94
ATB-25 ATB-55	.6255	15.89
	.7525	19.11
ATB-25 ATB-55	.7505	19.06
	.8775	22.29
ATB-25 ATB-55	.8755	22.24
	1.0025	25.46
ATB-55	1.0005	25.41
	1.1275	28.64
ATB-55 ATB-115	1.1255	28.59
	1.2525	31.81
ATB-115	1.2505	31.76
	1.3775	34.99
	1.3755	34.94
	1.5025	38.16
	1.5005	38.11

Specifications

Model Size	Voltage DC	Static Torque lb. ft.	Max. RPM	Weight lbs.	Inertia-WR ² lb.-ft. ²	Dynamic Torque @ 1800 RPM
25	6, 24 or 90	25	3600	7	.038	12 lb. ft.
55	6, 24 or 90	55	3600	15	.126	20 lb. ft.
115	6, 24 or 90	115	3600	24	.383	30 lb. ft.

Shaft Mounted Clutches

Warner Electric's packaged stationary field clutches are factory assembled and burnished to deliver the maximum rated torque immediately. In addition, a packaged product assures that all engineering factors regarding the proper alignment of components to one another have been established at the factory. This allows the unit to be 'slid on the shaft' after being shipped to you. The proper alignment of components is critical to achieving maximum torque and assuring long life.

Features

- No assembly required
- Anti-backlash armatures standard
- Ball bearing mounted field and armature hub
- Four sizes available
 - Size 180 – 15 in. lbs.
 - Size 250 – 70 in. lbs.
 - Size 325 – 125 in. lbs.
 - Size 400 – 270 in. lbs.

No brushes to wear out

Besides saving valuable assembly and run-in time, the SFP clutches incorporate an original Warner Electric concept. The concept of the stationary field eliminates the need for brushes. Brushes can be a high maintenance item in an electromagnetic clutch because of the mechanical friction seen at the collector ring. There is no mechanical friction with the stationary field design. In sum, all of the best possible features wrapped up into one compact package - **Warner Electric's SFP.**

Applications

- Packaging equipment
- Film readers
- Conveyors
- Medical equipment
- Sorting/feeding equipment

Functions

- Controlled, soft starts
- Speed variation
- High cycling



Shaft Mounted Clutches

Specifications

Model	Static Torque	Max.RPM
SFP-180	15 in.lb.	5000
SFP-250	70 in.lb.	7500
SFP-325	125 in.lb.	5000
SFP-400	270 in.lb.	5000

HP	SHAFT SPEED AT CLUTCH (IN RPM)																					
	100	200	300	400	500	600	700	800	900	1000	1100	1200	1500	1800	2000	2400	3000	3600	4000	4600	5000	
1/50																						
1/20																						
1/12															180							
1/8																						
1/6																						
1/4						325				250												
1/3																						
1/2																						
3/4																						
1																						
1-1/2																						
2																					400	
3																						

How to Order

1. Select the proper size from the chart (right).
2. Select the bore size and voltage.
3. Find the corresponding part number from the table below.
4. Select a Warner Electric Control if appropriate.

SFP-250

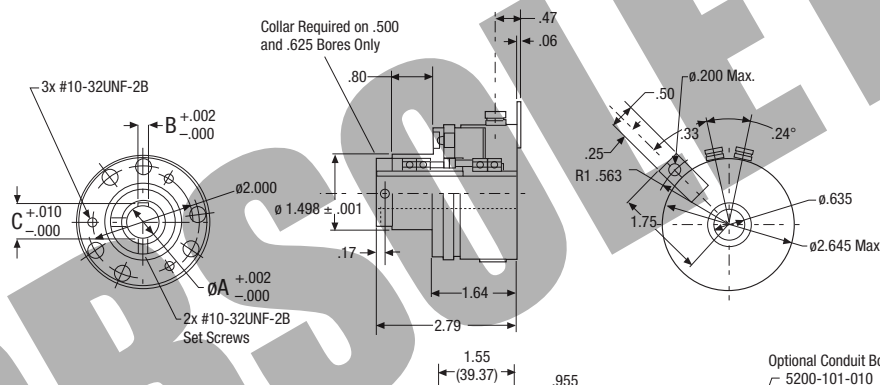

SFP-400

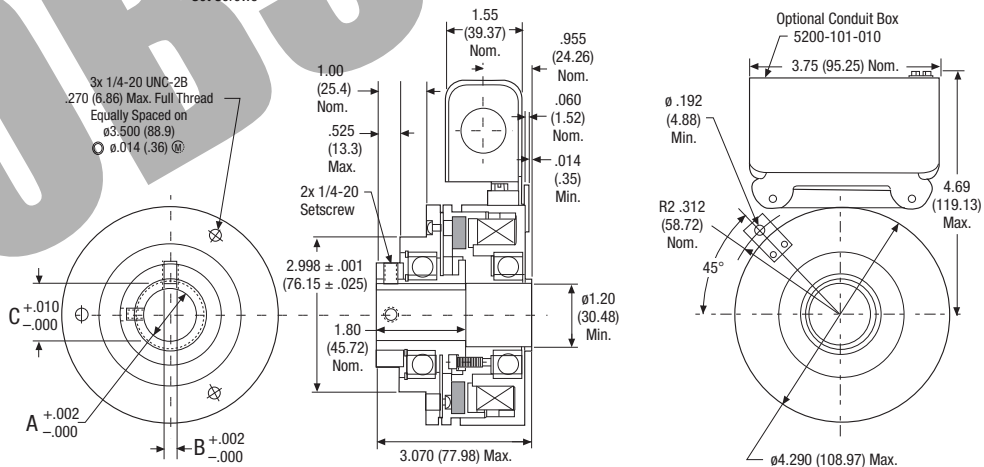

Tolerances

Model No.	A Bore	Keyway			Part Number		
		B	C	6V	24V	90V	
SFP-250	.375"	.0948	.421	5103-271-002	5103-271-006	5103-271-010	
	.438"	.126	.479	5103-271-003	5103-271-007	5103-271-011	
	.500"	.126	.560	5103-271-004	5103-271-008	5103-271-012	
	.6255"	.1885	.678	5103-271-005	5103-271-009	5103-271-013	
SFP-400	.5005"	.125	.560	5104-271-006	5104-271-016	5104-271-021	
	.6255"	.1875	.709	5104-271-007	5104-271-017	5104-271-022	
	.7505"	.1875	.837	5104-271-008	5104-271-018	5104-271-023	
	.8755"	.1875	.964	5104-271-009	5104-271-019	5104-271-024	
	1.0005"	.1875	1.090	5104-271-010	5104-271-020	5104-271-025	

Pre-Assembled SF Clutch For Parallel Shafts Model 180

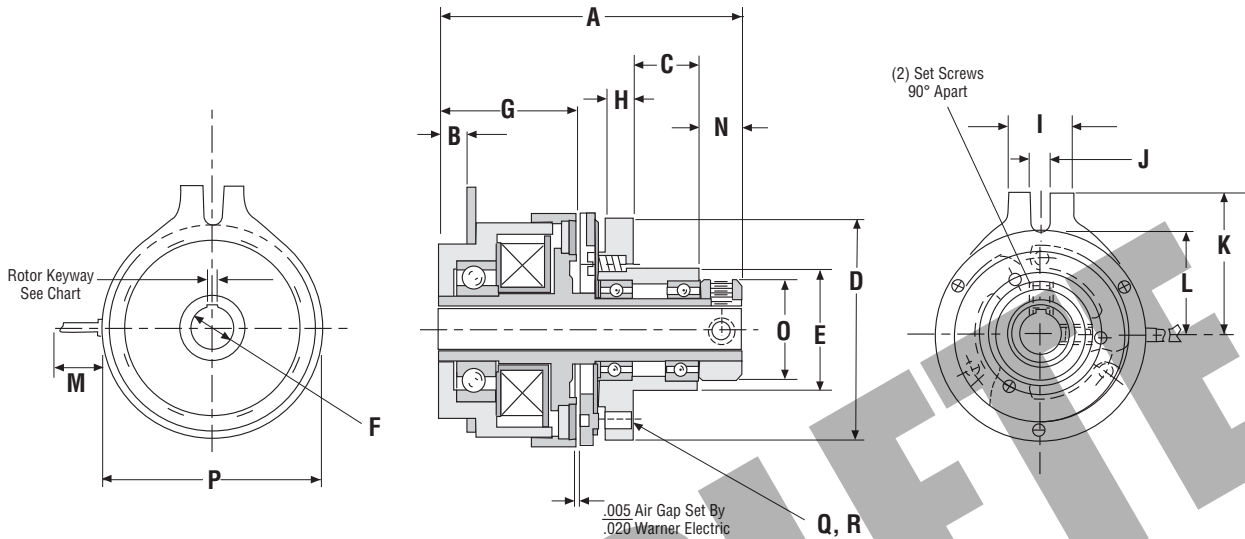

Dimensions

Model No.	A Max.	B Max.	C Nom.	D Max.	E ± .001	F Nom.	G Nom.	H Nom.	I Max.	J Min.	K Nom.	L Nom.	M ± .500	N Nom.	O Nom.	P Max.	Rotor Keyway			
																	Bore	Nominal Keyway	Q B.C.	R SIZE
180	2.515	.304	.500	1.755	.9985	$\frac{1}{4}$ $\frac{5}{16}$ $\frac{3}{8}$	1.290	.193	.505	.184	1.325	.975	12.00	.315	.875	1.620	N.A.	SET SCREWS ONLY	1.437 3-Holes	8-32 UNC-2B

Mechanical

Model No.	Static Torque lb. - in.	Inertia lb. - in. ²		Wt. oz.
		Rotor	Arm & Hub	
180	15	.052	.095	26

Electrical

Model No.	90 VDC		24 VDC	
	Amps	Ohms	Amps	Ohms
180	.066	1369	.289	83.1

Part Numbers

Model Size	Bore Size	Voltage DC	Part No.
180	1/4"	24	SFP180-14-24
	5/16"	24	SFP180-516-24
	3/8"	24	SFP180-38-24
	1/4"	90	SFP180-14-90
	5/16"	90	SFP180-516-90
	3/8"	90	SFP180-38-90

Customer shall maintain:

A loose-fitting pin through the anti-rotation tab to prevent preloading the bearings.

Pre-Assembled SF Clutch For Parallel Shafts
Model 325

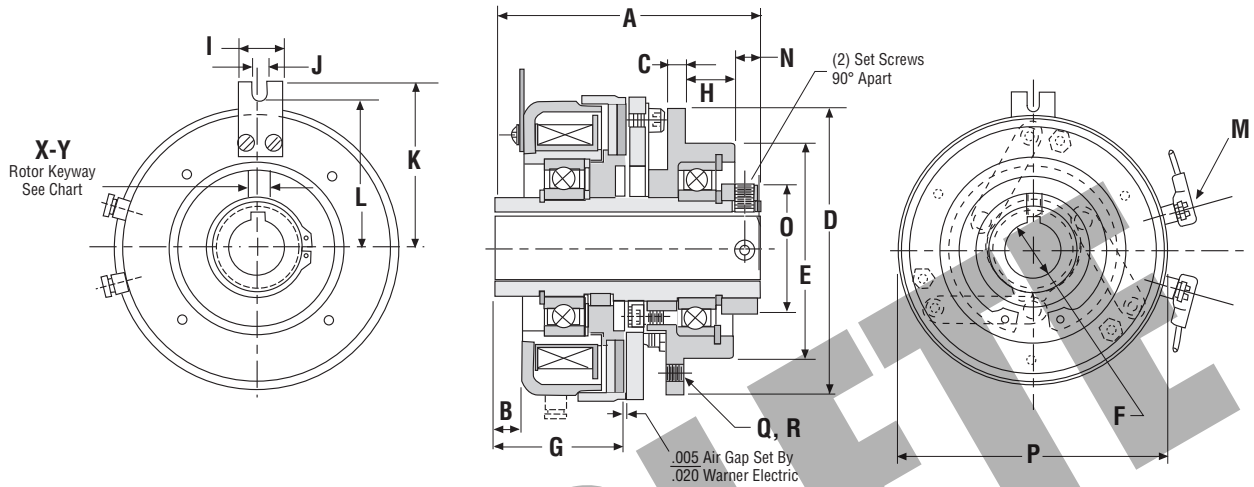

Dimensions

Model No.	A Max.	B Max.	C Nom.	D Max.	E ±.001	F Nom.	G Nom.	H Nom.	I Max.	J Min.	K Nom.	L Nom.	M ±.500	N Nom.	O Nom.	P Max.	Rotor Keyway		Q B.C.	R SIZE	
																	Nominal X*	Y*			
325	2.961	.140	.395	2.883	1.498	1/2	1.360	.500	.442	.170	2.050	1.740	Screw Terminals	.408	1.187	3.300	1/2	.125 - .128	.560 - .567	1.790 3-Holes	6-32 UNC-2B

*7/8 and 1 inch bore in rotor only.

Mechanical

Model No.	Static Torque lb. - in.	Inertia lb. - in. ²		
		Rotor	Arm & Hub	Wt. oz.
325	125	.560	.990	54

Electrical

Model No.	90 VDC		24 VDC	
	Amps	Ohms	Amps	Ohms
325	.091	988	.378	65.3

Lead wire is UL recognized style 1213, 1015 or 1430, 22 gage. Insulation is .0509 O.D. on 110 units; .0649 or .0959 O.D. on all other units.

Part Numbers

Model Size	Bore Size	Voltage DC	Part No.
325	1/2"	24	SFP325-12-24
	1/2"	90	SFP325-12-90

Customer shall maintain:

A loose-fitting pin through the anti-rotation tab to prevent preloading the bearings.

EP Series Electro Pack

Base Mounted Clutch/Brake Combinations in a Rugged Housing

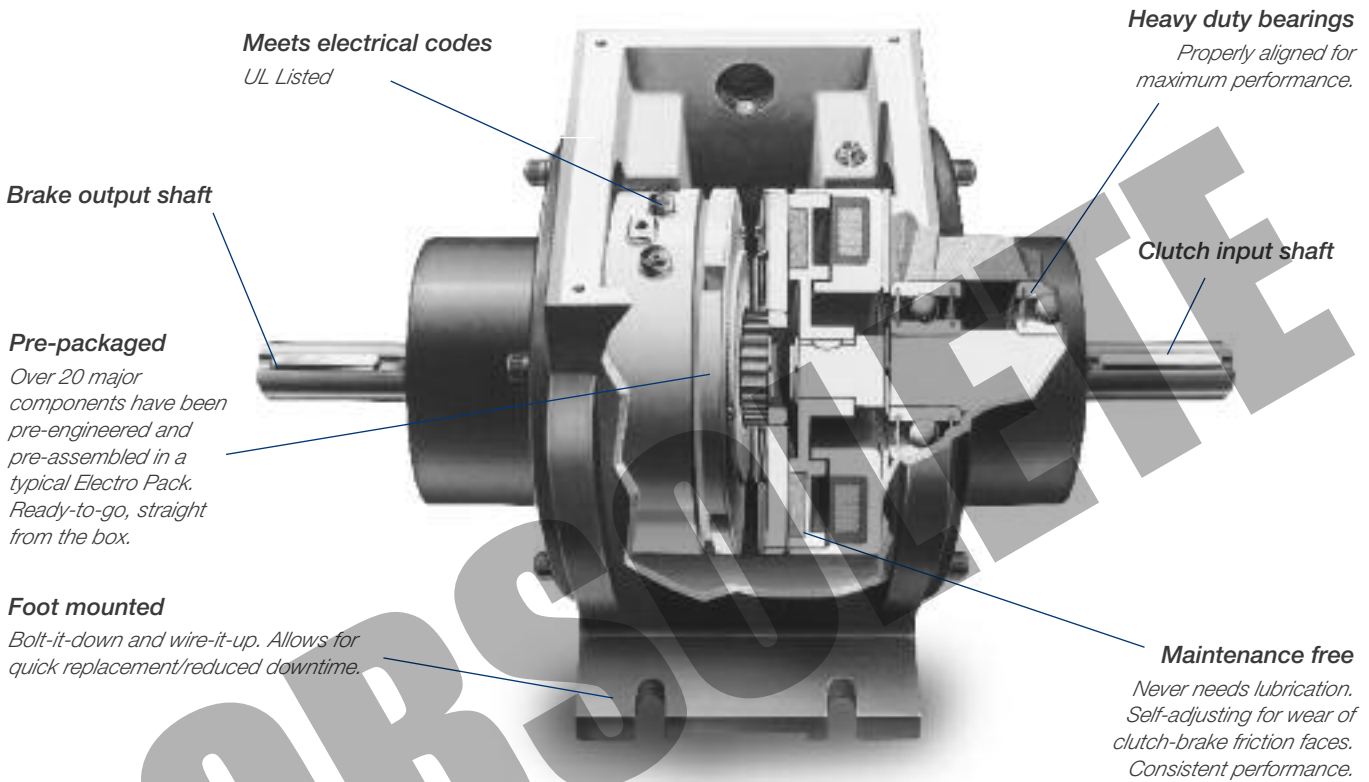

Electro Packs are rugged, pre-assembled clutch and brake combinations in an enclosed, foot mounted housing.

They are factory aligned and pre-assembled and have been designed to mate easily with industry standard motors and reducers with v-belts, pulleys, chain and sprockets, in line couplings and timing belt drives.

Features

- Bolt-it-down and wire-it-up . . . it's ready to go!
- Maintenance free
- A wide torque range from 15 lb. in. to 1350 lb. ft.

Typical Application

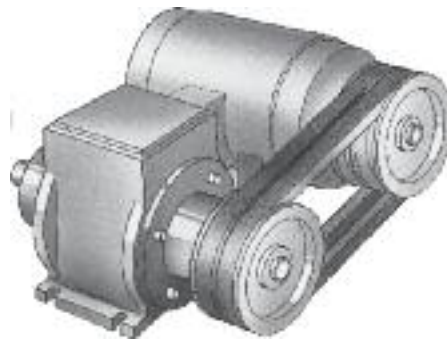

A foot mounted Electro Pack combines with a motor in a parallel shaft drive application.

Selection/Ordering Information

Horsepower vs. Shaft Speed

HP ▼	SHAFT SPEED AT CLUTCH (IN RPM)																					
	100	200	300	400	500	600	700	800	900	1000	1100	1200	1500	1800	2000	2400	3000	3600	4000	4500	5000	
1/50																						
1/20																						
1/12																						
1/8																						
1/6																						
1/4																						
1/3																						
1/2																						
3/4																						
1																						
1-1/2																						
2																						
3																						
5																						
7-1/2																						
10																						
15																						
20																						
25																						
30																						
40																						

Selection Procedure

Determine the shaft speed at the Electro Pack location. The number listed at the intersection of horsepower and speed is the size Electro Pack you require.

Part Numbers

Model No.	Voltage DC	Part No.
EP-170	6	5633-273-002
	24	5633-273-003
	90	5633-273-005
EP-250	6	5130-273-031
	24	5130-273-032
	90	5130-273-034
EP-400	6	5131-273-009
	24	5131-273-010
	90	5131-273-011
EP-500	6	5230-273-003
	24	5230-273-011
	90	5230-273-002
EP-825	6	5231-273-003
	24	5231-273-004
	90	5231-273-002
EP-1000	6	5232-273-003
	24	5232-273-005
	90	5232-273-002
EP-1525	6	5234-273-003
	90	5234-273-002
EP-1525HT	24	5234-273-017
	90	5234-273-012

When ordering, specify size, voltage, and part numbers.

Specifications

Electro-Pack Size	Horsepower @ 1800 RPM	Static Torque	Max. RPM	Voltage DC
EP-170	1/8	15 lb. in.	10,000	6, 24 or 90
EP-250	1/2	70 lb. in.	7,500	6, 24 or 90
EP-400	1	270 lb. in.	4,500	6, 24 or 90
EP-500	2	50/40 lb. ft.	4,000	6, 24 or 90
EP-825	7-1/2	125 lb. ft.	3,600	6, 24 or 90
EP-1000	10	240 lb. ft.	3,000	6, 24 or 90
EP-1525	25	700 lb. ft.	1,800	6 or 90
EP-1525HT	40	1350 lb. ft. clutch 700 lb. ft. brake	1,800	24, 90

EP Series Electro Pack

EP-170, EP-250, EP-400

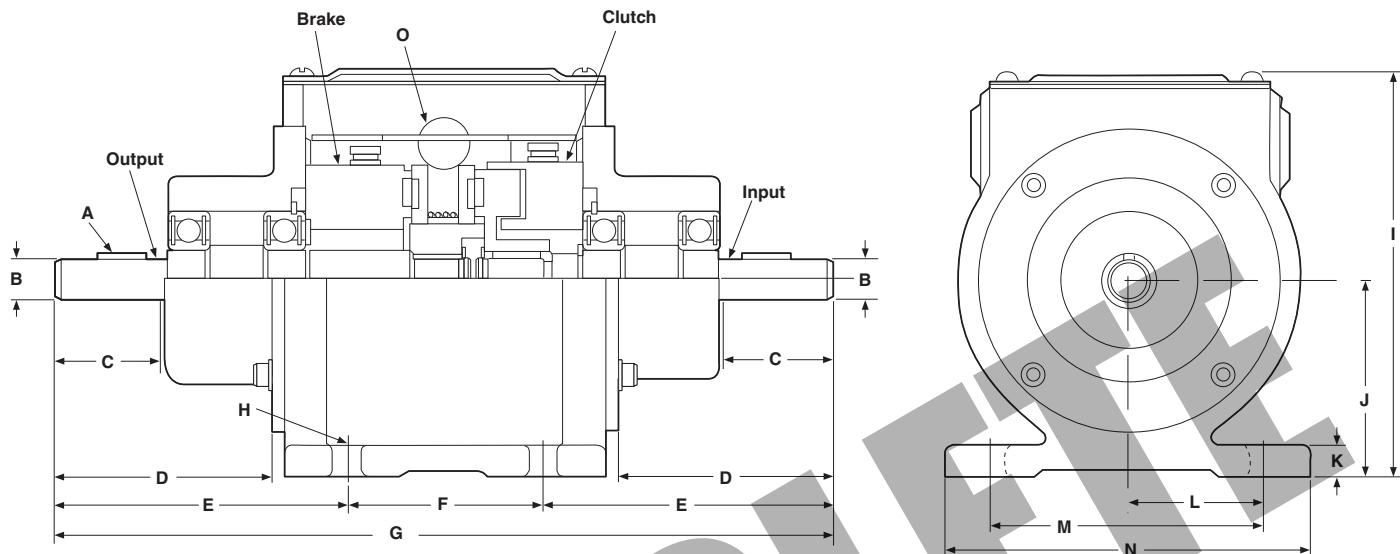

Dimensions

All dimensions are nominal, unless otherwise noted.

Size	A	B	C Min.	D	E	F	G Max.	H	I	J	K	L	M	N	O
170	3/32 x 3/64	.3745 .3735 Dia.	.750	1.406	2.203	1.500	6.000	.250 Wide (4 slots)	3.437	1.662 1.652	.312	1.110	2.220	3.250	1/2 14 NPT Conduit x 2
250	1/8 x 1/16	.4995 .4985 Dia.	1.250	2.468	3.312	2.250	8.968	.312 Wide (4 slots)	5.281	2.318 2.308	.375	1.625	3.250	4.250	1/2 14 NPT Conduit x 2
400	3/16 x 3/16 x 1-1/2	.7495 .7485 Dia.	1.875	3.515	4.593	2.500	11.781	.312 Wide (4 slots)	6.937	3.474 3.464	.500	2.578	5.156	6.000	1/2 14 NPT Conduit x 2

Specifications

Model Size	Voltage DC	Static Torque lb. in.	Inertia*—WR ² (lb-in ²)		Max. RPM	Weight lbs.
			Output	Input		
EP-170	6	15	.031	.036	10,000	2.5
	24	15	.031	.036	10,000	2.5
	90	15	.031	.036	10,000	2.5
EP-250	6	70	.331	.293	7,500	7.1
	24	70	.331	.293	7,500	7.1
	90	70	.331	.293	7,500	7.1
EP-400	6	270	2.566	2.222	4,500	19.7
	24	270	2.566	2.222	4,500	19.7
	90	270	2.566	2.222	4,500	19.7

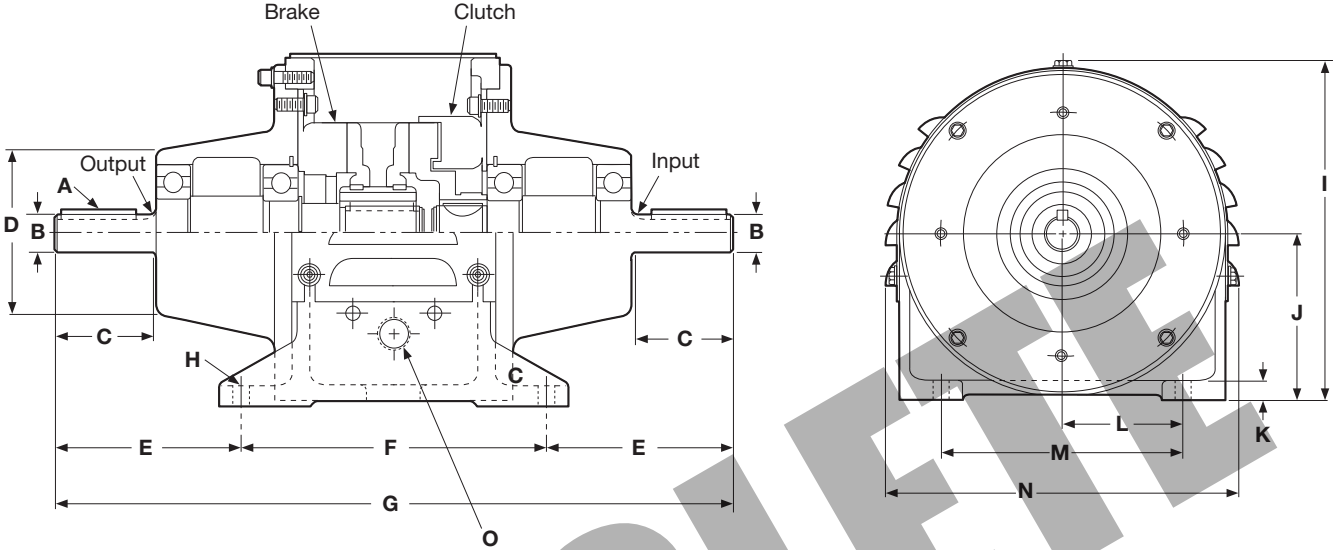

Dimensions

All dimensions are nominal, unless otherwise noted.

Size	A	B Dia.	C Min.	D Max. Dia.	E	F	G Max.	H Dia.	I	J	K	L	M	N Max.	O
500	3/16 x 1-3/4	.8750	2.218	3.796	4.234	7.000	15.515	.406 (4 holes)	8.218	4.004	.500	2.937	5.875	8.734	1/2 NPT Conduit x 2

Specifications

Model Size	Voltage DC	Unit	Static Torque	Inertia*—WR ² lb.ft. ²	Max. RPM	Weight lbs.
EP-500	6, 24 and 90	Clutch Brake	50 40	.039 .063	4000	56

EP Series Electro Pack

EP-825

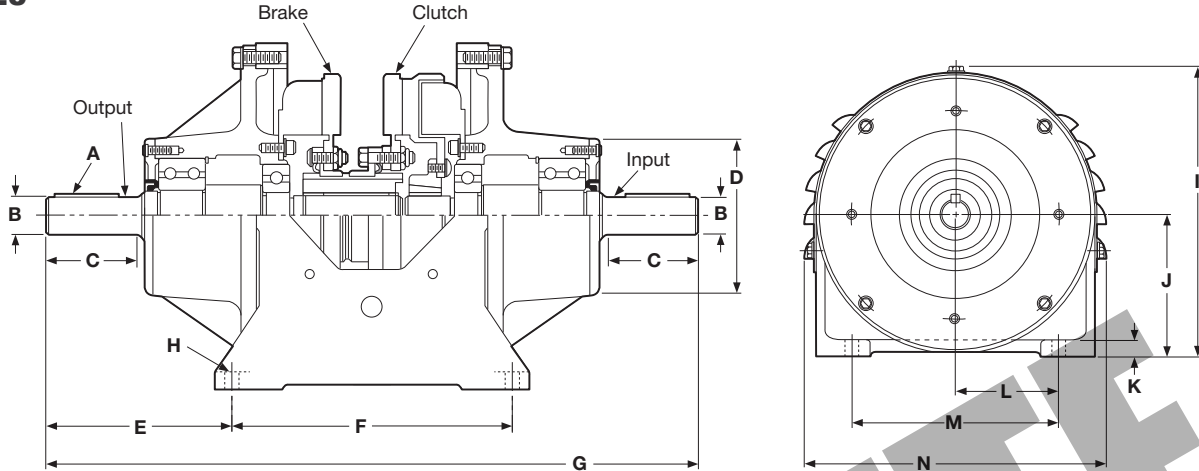

Dimensions

All dimensions are nominal, unless otherwise noted.

Size	A	B Dia.	C Min.	D Max. Dia.	E	F	G Max.	H	I	J	K	L	M	N Max.
825	1/4 x 1/4 x 2	1.1250 1.1245	2.875	5.000	5.734	8.500	20.031	.406 Dia. (4 holes)	10.812	5.254 5.252	.562	4.250	8.500	11.609

Specifications EP-825

Model Size	Voltage DC	Unit	Static Torque	Inertia*–WR ² lb.ft.2	Max. RPM	Weight lbs.
EP-825	6, 24 & 90	Clutch Brake	125 125	.651 .242	3600	123

EP-1000

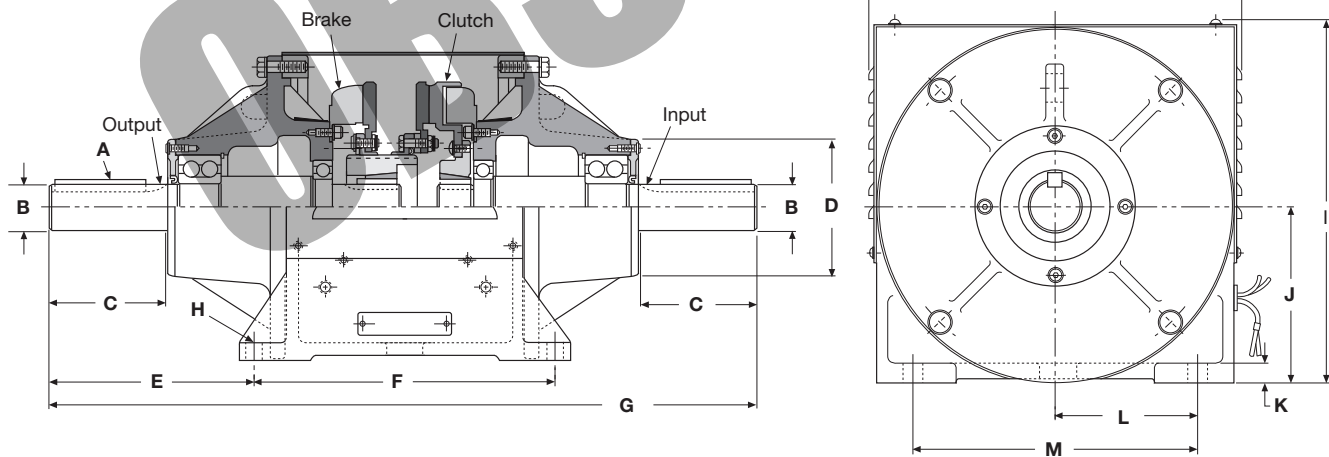

Dimensions

All dimensions are nominal, unless otherwise noted.

Size	A	B Dia.	C Min.	D Dia.	E	F	G Max.	H	I	J	K	L	M	N Max.
1000	1/2 x 1/2 x 3-3/4	1.875 1.874	4.750	5.687	8.250	12.250	28.750	.656 Dia. (4 holes)	12.500	6.255 6.241	.718	5.000	10.000	12.875

Specifications EP-1000

Model Size	Voltage DC	Static Torque	Inertia*–WR ² (lb-ft ²)		Max. RPM	Weight lbs.
			Output Side	Input Side		
EP-1000	6	240 lb.ft.	1.45	1.01	3000	288
	24	240 lb.ft.	1.45	1.01	3000	288
	90	240 lb.ft.	1.45	1.01	3000	288

EP Series Electro Pack

EP-1525, EP-1525HT

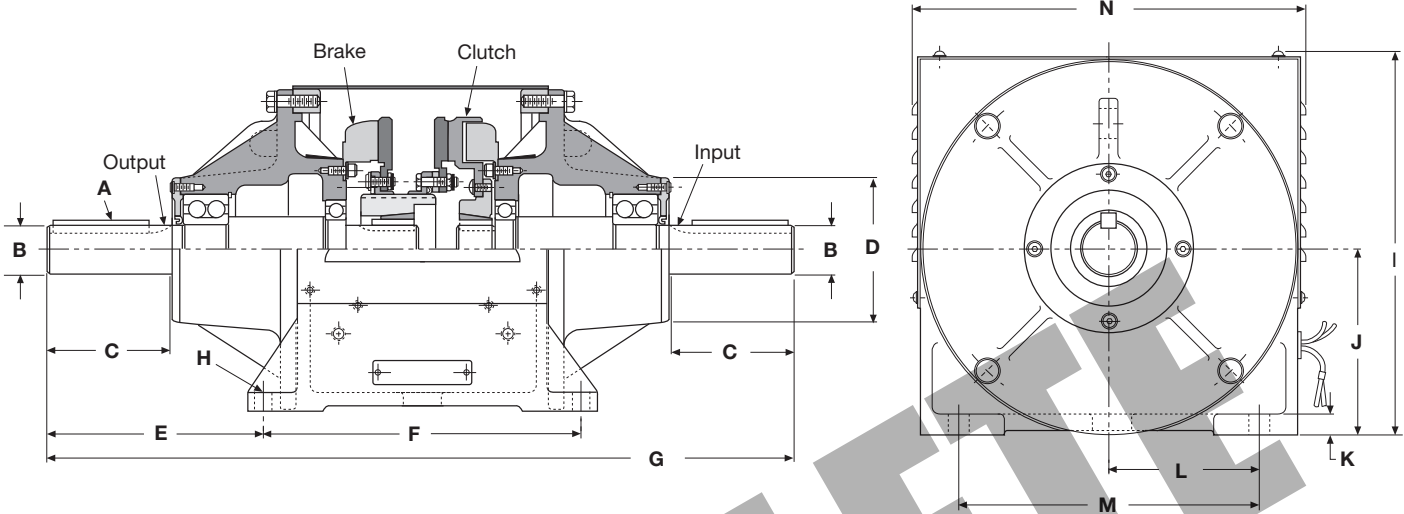

Dimensions

All dimensions are nominal, unless otherwise noted.

Size	A	B Dia.	C Min.	D Max. Dia.	E	F	G Max.	H	I	J	K	L	M	N Max.
1525	5/8 x 5/8 x 4-1/4	2.375 2.374	5.750	7.500	8.468	16.500	33.500	.796 Dia. (4 holes)	18.250	9.005 8.991	1.000	7.000	14.000	18.875
1525HT	5/8 x 5/8 x 4-1/4	2.375 2.374	5.750	7.500	8.468	16.500	33.500	.796 Dia. (4 holes)	18.250	9.005 8.991	1.000	7.000	14.000	18.875

Specifications

Model Size	Voltage DC	Unit	Static Torque lb.ft.	Inertia*—WR ² lb.ft. ²		Max. RPM	Weight lbs.
				Output	Input		
EP-1525	6, 90	Clutch Brake	700 700	7.89	5.68	1800	655
EP-1525HT	24, 90	Clutch Brake	1350 700	7.89	6.41	1800	656

EP-C Series Electro Pack – Ceramic Faced

PerformancePlus™ clutch/brake combination in a foot mounted housing

Single point wire exit

Pre-packaged

Major components have been pre-engineered and pre-assembled in a typical Electro Pack. Ready-to-go, straight from the box.

PerformancePlus™ Electro Packs use ceramic friction system technology. This technology has been in use for many years in specialized applications. Through the development of advanced manufacturing techniques, the improved performance of ceramic friction materials are now available as standard products off the shelf.

PerformancePlus™ Electro Packs with ceramic friction material are rugged, pre-assembled clutch and brake combinations in base mounted housings. They have been designed to be installed in standard power transmission systems with V-belts and pulleys, chain and sprockets, in line couplings, and timing belt drives.

When your application calls for a long life clutch/brake because of high cycle rates or demanding consistency, choose the PerformancePlus solution.

- Bolt-it-down and wire-it-up . . . it's ready to go!
- Available in two size; 170 and 250. Standard voltages are 24V and 90V DC.
- Maintenance free.
- Ideal for use with CBC 1000 indexers and CBC 700 OEX control.

PerformancePlus™ . . . the demanding application choice.

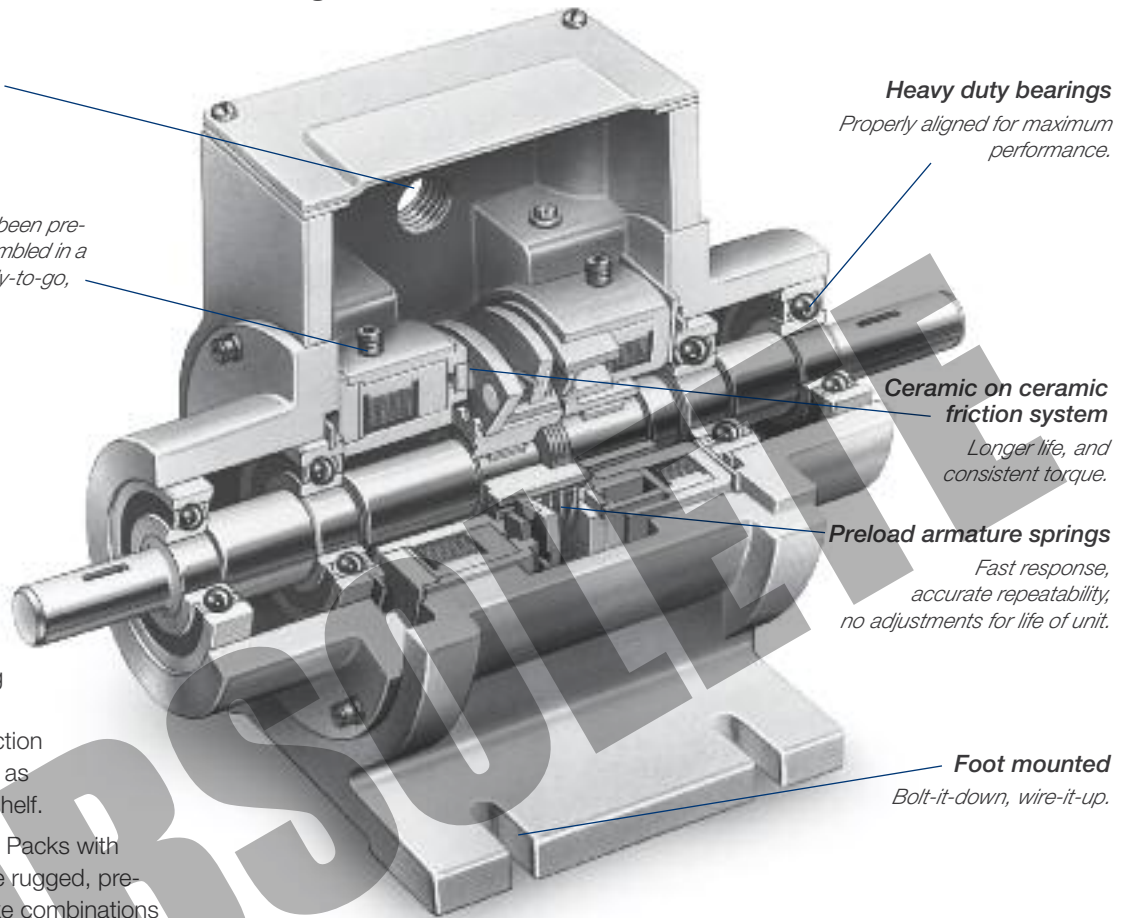

EP-C Product Life

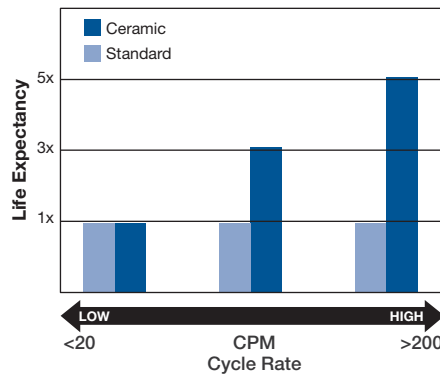

Extended Life for High Cycle Rate Use

Ceramic faced clutches and brakes have been designed specifically for rapid cycling applications to satisfy today's needs for high speed equipment. Ceramic friction material provides excellent wear resistance that extends life 3 to 5 times that of standard clutch/brakes in demanding applications.

EP-C Cycle Repeat

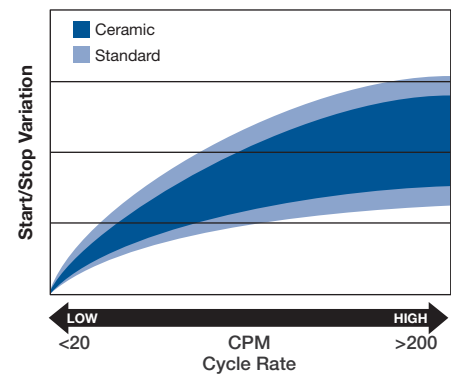

Consistent Torque and Cycle Repeatability

Preloaded armatures keep the ceramic friction surfaces in light contact, providing consistent torque and cycle-to-cycle repeatability. Variation is reduced by up to 30% over standard units.

EP-C Series Electro Pack – Ceramic Faced

Applications/Selection

Controllability Smooth Start/Stop

With the ceramic friction surfaces always in contact, dynamic torque response is fast and precise. When used with a CBC-700 over-excitation control and CBC-1000 programmable counter, exceptional closed loop clutch/brake performance can be achieved approaching that of more expensive motion control technologies – The PerformancePlus difference!

Selection

PerformancePlus Electro Packs are best suited for high energy applications where long life is a premium concern. The harder a ceramic friction surface is worked, the more wear life benefit is achieved. For slower cycle rates, up to 75 cycles per minute, dependable standard clutch/brakes are still a good choice.

For high cycle rates and high energy use (generally more than 50 cycles/minute for EP-170's and EP-250's) PerformancePlus clutch/brakes are the choice.

Technical considerations for sizing and selection are torque and heat dissipation. Each merits careful consideration, especially heat dissipation. Over temperature use will have an adverse effect on bearing life and coil wire insulation integrity.

For proper sizing information, refer to the Horsepower vs. Shaft Speed chart, and the technical sizing considerations below. When ordering, specify size, voltage, and part number.

Typical Applications

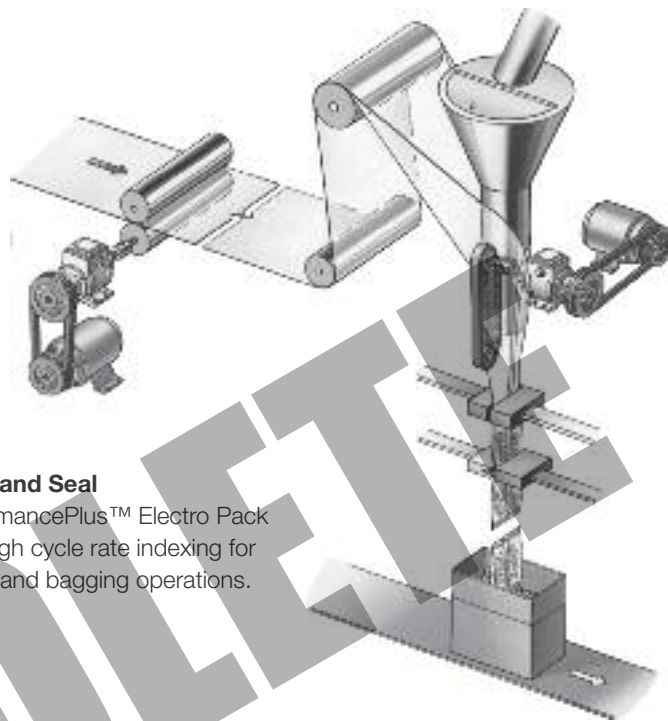

Form, Fill and Seal

The PerformancePlus™ Electro Pack provides high cycle rate indexing for packaging and bagging operations.

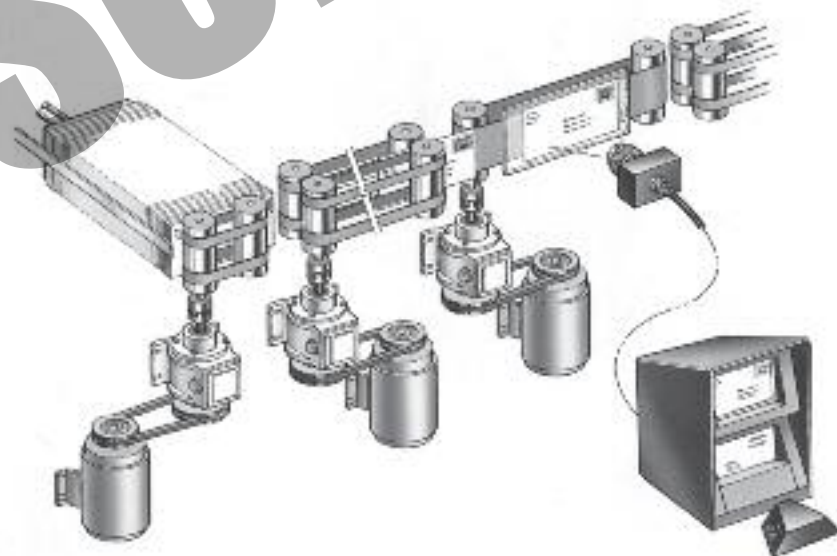

Mail Processing

The PerformancePlus Electro Pack provides fast cycling and accurate starting and stopping.

Horsepower vs. Shaft Speed

HP	SHAFT SPEED AT CLUTCH (IN RPM)																				
	100	200	300	400	500	600	700	800	900	1000	1100	1200	1500	1800	2000	2400	3000	3600	4000	4600	5000
1/50	■	■	■	■	■	■	■	■	■	■	■	■	■	■	■	■	■	■	■	■	■
1/20		■	■	■	■	■	■	■	■	■	■	■	■	■	■	■	■	■	■	■	■
1/12			■	■	■	■	■	■	■	■	■	■	■	■	■	■	■	■	■	■	■
1/8				■	■	■	■	■	■	■	■	■	■	■	■	■	■	■	■	■	■
1/6					■	■	■	■	■	■	■	■	■	■	■	■	■	■	■	■	■
1/4						■	■	■	■	■	■	■	■	■	■	■	■	■	■	■	■
1/3							■	■	■	■	■	■	■	■	■	■	■	■	■	■	■
1/2								■	■	■	■	■	■	■	■	■	■	■	■	■	■
1									■	■	■	■	■	■	■	■	■	■	■	■	■

EP-C Series Electro Pack – Ceramic Faced

Selection/Ordering Information

Heat Dissipation Sizing

Friction surfaces slip during the initial period of engagement and, as a result, heat is generated. The clutch/brake selected must have a heat dissipation rating greater than the heat generated by the application.

Therefore, in high inertia or high cycle rate applications, it is necessary to check the heat dissipation carefully. Inertia, speed and cycle rate are the required parameters.

These curves show the heat dissipation capability of the ceramic units.

Heat dissipation requirement is calculated as follows:

$$E = 1.7 \times WR^2 \times \left(\frac{N}{100}\right)^2 \times F$$

where:

- E = Heat (lb.ft./min.)
- WR² = Total reflected inertia at the clutch/brake shaft. Include the clutch/brake output inertia. (lb.ft.²)
- N = Speed in revolutions per minute. (RPM)
- F = Cycle rate in cycles per minute. (CPM)

Compare the calculated heat generated in the application to the unit ratings using the heat dissipation curves. Select the appropriate unit that has adequate heat dissipation ability.

EP-170-C

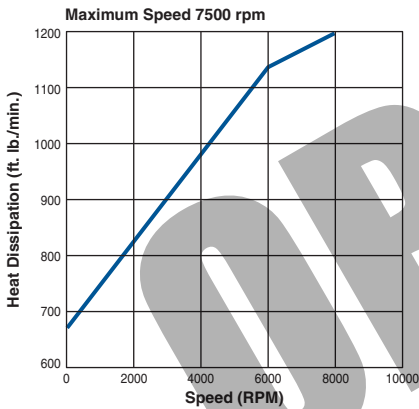

EP-250-C

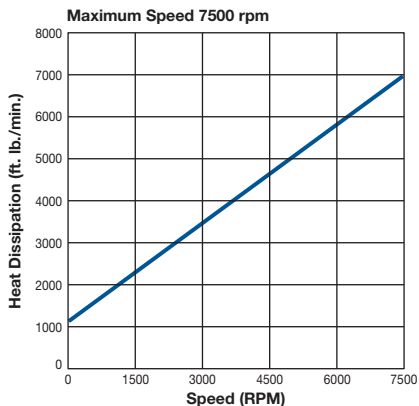

Dynamic Torque Sizing

These curves show the average dynamic torque during the slip period of engagement. Find the dynamic torque value on the curve at the clutch/brake input speed.

EP-170-C EP-250-C

EP-170-C Maximum Speed 10000 rpm
Static Torque 15 lb. in.
EP-250-C Maximum Speed 7500 rpm
Static Torque 70 lb. in.

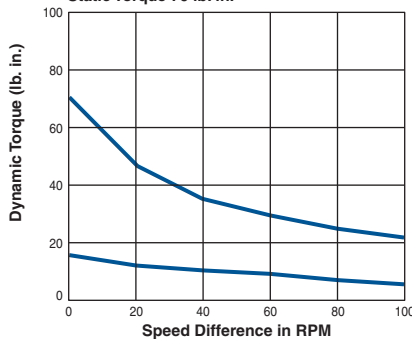

For most applications, the correct size clutch/brake can be selected from the horsepower/shaft speed selection chart. Determine the motor horsepower and the RPM at the clutch/brake. The correct size unit is shown at the intersection of horsepower and shaft speed.

If the static torque requirements are known, refer to the technical ratings chart to select a unit.

Torque Ratings

Model Size	Max. RPM	Static Torque	Voltage DC
EP-170-C	10,000	15 lb. in.	24 & 90
EP-250-C	7500	70 lb. in.	24 & 90

For some applications, the torque requirement is determined by the time allowed to accelerate and decelerate the load. (This time is generally specified in milliseconds.) For these applications, it is necessary to determine the torque requirement based on load inertia and the time allowed for engagement.

The torque requirements are calculated as follows:

$$T = \frac{WR^2 \times N}{308 \times t}$$

where:

- T = Average Dynamic Torque (lb. ft.) (For EP selection, multiply by 12 to convert to units of lb. in.)
- WR² = Total reflected inertia at the clutch/brake shaft. Include the clutch/brake output inertia. (lb. ft.²)
- N = Speed in revolutions per minute. (RPM)
- t = Time allowed for the engagement (sec)

Compare the calculated torque requirement with the average dynamic torque ratings. Select a unit with adequate torque. If the unit selected on torque is different than the unit selected based on heat, select the larger unit size.

Part Numbers

Model Size	Voltage DC	Part No.
EP-170-C	24V	5633-273-018
	90V	5633-273-019
EP-250-C	24V	5130-273-053
	90V	5130-273-054

EP-C Series Electro Pack – Ceramic Faced

EP-170-C, EP-250-C

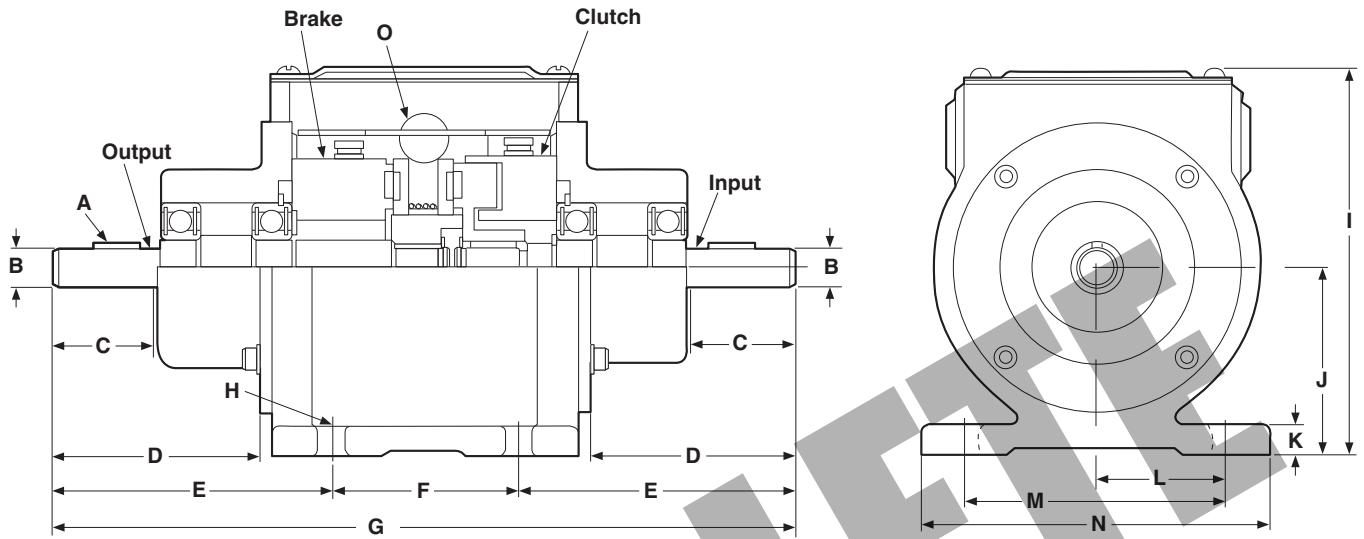

All dimensions are nominal, unless otherwise noted.

Size	A	B Dia.	C Min.	D	E	F	G Max.	H	I	J	K	L	M	N	O
170-C	3/32 x 3/64	.3745 .3735	.750	1.406	2.203	1.500	6.000	.250 Wide (4 slots)	3.437	1.662 1.652	.312	1.125	2.250	3.250	14 NPT 1/2 conduit
250-C	1/8 x 1/16	.4995 .4985	1.230	2.468	3.312	2.250	8.968	.312 Wide (4 slots)	5.281	2.318 2.308	.375	1.625	3.250	4.250	14 NPT 1/2 conduit

Specifications

Model Size	Voltage DC	Unit	Static Torque lb. in.	Inertia*–WR ² lb.ft. ²		Max. RPM	Weight lbs.
				Output	Input		
170-C	24	Clutch	15	.031	.036	10,000	2.8
		Brake	15	.031	.036	10,000	2.8
	90	Clutch	15	.031	.036	10,000	2.8
		Brake	15	.031	.036	10,000	2.8
250-C	24	Clutch	70	.331	.293	7,500	7.5
		Brake	70	.331	.293	7,500	7.5
	90	Clutch	70	.331	.293	7,500	7.5
		Brake	70	.331	.293	7,500	7.5

Washdown Electro Pack

If your clutch/brake application demands consistent, repeatable performance cycle after cycle, through wet and dry conditions, choose Warner Electric's Washdown Electro Pack Clutch/Brakes.

Even in the most demanding environments, Washdown Electro Pack Clutch/Brakes (EP-W) will weather the storm. Designed specifically for use in food, sanitary or any other washdown application, these packaged clutch/brakes are totally enclosed in smooth, completely sealed, rugged enclosures to keep wear particles in and contaminants out.

Washdown Electro Packs are factory aligned, assembled and burnished for consistent out-of-the-box performance.

- USDA Approved coating
- Smooth exterior
- Shielded/sealed bearings
- Available in 70 and 270 lb-in Static torque configurations
- Available in 24 and 90 vdc

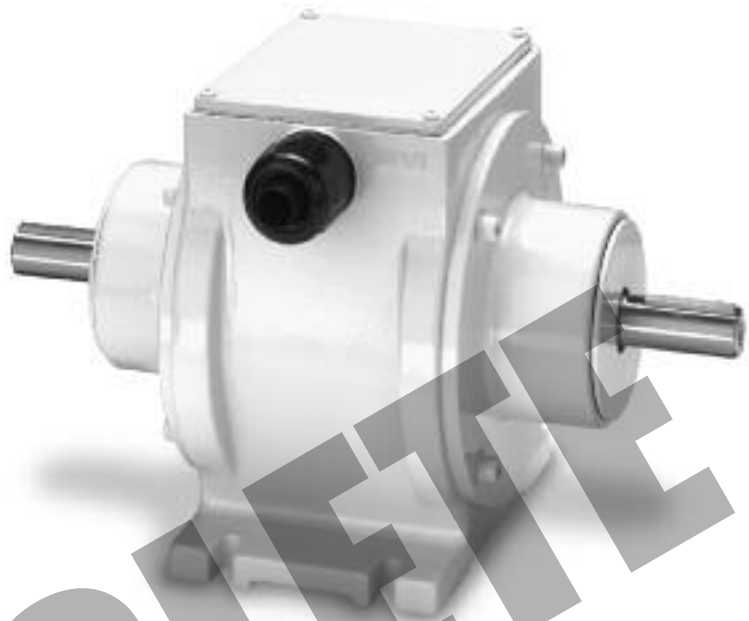

Horsepower vs. Shaft Speed

HP ▼	SHAFT SPEED AT CLUTCH (IN RPM)																					
	100	200	300	400	500	600	700	800	900	1000	1100	1200	1500	1800	2000	2400	3000	3600	4000	4500	5000	
1/50																						
1/20																						
1/12																						
1/8																						
1/6																						
1/4																						
1/3																						
1/2																						
3/4																						
1																						
1-1/2																						
2																						
3																						

Washdown Electro Pack Clutch/Brakes

Warner Electric's new Washdown Electro Packs are currently available in two sizes, and in 24 and 90 volt configurations. If your application requires a different voltage or mounting configuration, please contact Warner Electric for assistance.

Model	Voltage (DC)	Max RPM	Static Torque (lb-in)	Part Number
EP-250-W	24	7500	70	5130-273-060
	90			5130-273-061
EP-400-W	24	4500	270	5131-273-030
	90			5131-273-031

Washdown Electro Pack

EP-250 and EP-400

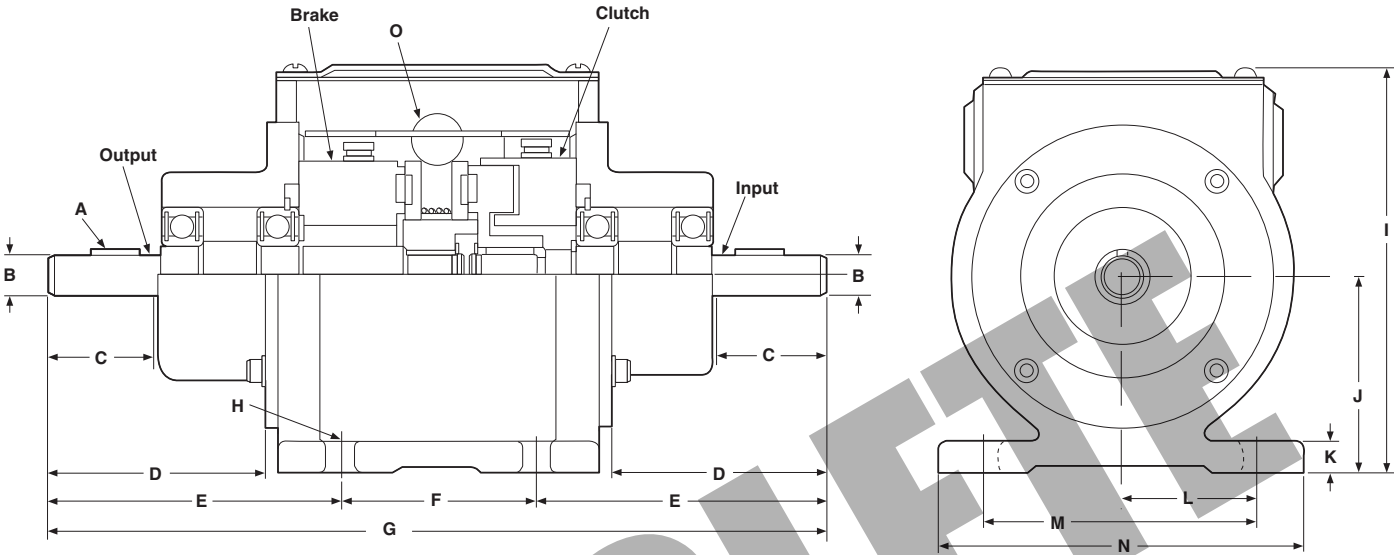

Dimensions

All dimensions are nominal, unless otherwise noted.

Size	A	B	C Min.	D	E	F	G Max.	H	I	J	K	L	M	N	O
250	1/8 x	.4995	1.250	2.468	3.312	2.250	8.968	.312 Wide (4 slots)	5.281	.2318	.375	1.625	3.250	4.250	1/2 14 NPT Conduit x 2
	1/16	.4985 Dia.								2.308					
400	3/16 x	.7495	1.875	3.515	4.593	2.500	11.781	.312 Wide (4 slots)	6.937	.3474	.500	2.578	5.156	6.000	1/2 14 NPT Conduit x 2
	3/16 x 1-1/2	.7485 Dia.								3.464					

Specifications

Model Size	Voltage DC	Static Torque lb. in.	Inertia*—WR ² (lb-in ²)		Max. RPM	Weight lbs.
			Output	Input		
EP-250-W	6	70	.331	.293	7,500	7.1
	24	70	.331	.293	7,500	7.1
	90	70	.331	.293	7,500	7.1
EP-400-W	6	270	2.566	2.222	4,500	19.7
	24	270	2.566	2.222	4,500	19.7
	90	270	2.566	2.222	4,500	19.7

Selection Guide Electrically Released Brakes

Electrically Released brakes fall within two categories: **Static Engage** and **Dynamic Stopping**. Static engage brakes are similar in function to an automotive parking brake: while they can be used to stop in an emergency, they are primarily to hold a load stationary after the load is already stopped. A static engage brake that is used as an active stopping brake at high cycle rate will wear out quickly.

Common industrial static applications are vertical or incline conveyors. The drive and motor may decelerate the conveyor to a stop and then engage the brake to hold the load in position. A second common application is where a servo or step motor will accelerate and decelerate the load and the brake holds the load in proper position.

Dynamic engage brakes are those designed to actively stop and hold the load. In these applications the brake is the force that stops the load as well as hold it. Dynamic engagement brakes are designed to provide appropriate life in applications where they experience frequent cycles per minute.











All electrically released brakes will engage when power is turned off and as such will provide emergency stop braking.

Static Engage Brakes

- ERS
- ERD
- EM/ERS

Dynamic Engage Brakes

- FB
- ER
- EM-FBB, FBC, MBFB
- UM-FBC and MBFB
- Unibrake

	Model	Description / Application
Static Engage	ERS 	The ERS family of brakes is a spring set/ electrically released design. Excellent for use in holding applications. Torque ranges from 1.5 to 100 foot pounds.
	ERD 	The ERD family of brakes is a spring set/ electrically released design similar in concept to the ERS designs. The ERD family extends the torque ratings from 3 to 220 foot pounds. The ERD family also includes an adjustable torque option and manual release option.
	EM/ERS 	For C-face mounted applications the EM/ERS provides the ERS design with the easy to mount C-face mounting.
Dynamic Engage	ER 	ER brakes provide a permanent magnet engage/electrically released design. The customer assembled design of the ER family allows for ease of installation into unique customer applications requiring torque ranges from 10 to 400 foot pounds.
	FB 	The bearing mounted FB products are a permanent magnet engage/electrically released design. The bearing mounted design allows for simple mounting using just a torque arm for applications where a pre-assembled unit is desired and no mounting flange is available. Torque ranges from 10 to 56 foot pounds.
	FBB 	The C-face mount FBB units are designed to mount on the output side of a C-face motor where a brake only configuration is appropriate.
	MBFB 	The MBFB designs are the same as the FBB, except they are for the back of motor mounting for double C-face motors.
	FBC 	The C-face mount FBC units are designed to work with the clutch design for applications needing an electrically engaged clutch and electrically released brake.
	Unibrake 	The Unibrake designs are a spring set/ solenoid release brake for mounting to the back of the motor. This is a lower cost, lower cycle rate design compared to the MBFB. Adjustable torque and manual release are standard features.
	Unibrake Coupler 	The coupler design of the Unibrake family is designed for mounting on the output side of a motor where a spring set/solenoid release brake is desired. Adjustable torque and manual release are standard features.

Selection Guide Electrically Released Brakes

Load Holding	Manual Release	Bearing Mount	Flange Mount	C-Face Mtg Front of Motor	C-Face Mtg Back of Motor	Back of Motor Mount	Back of Motor Enclosure	Coil Voltage	Adjustable Torque
yes	no	-	-	no	-	yes	no	DC	no
yes	yes	-	-	no	-	yes	no	DC	yes
yes	no	-	-	yes	-	no	no	DC	no
yes	no	no	yes	no	no	-	-	DC	yes
yes	no	yes	no	no	no	-	-	DC	yes
yes	no	no		brake only	no	-	-	DC	yes
yes	no	no		no	yes	-	-	DC	yes
yes	no	no		with clutch	no	-	-	DC	yes
yes	yes	no		no	yes	-	-	AC	yes
yes	yes	no		yes	no	-	-	DC or AC	yes

OBSOLETE

Spring-Set Electrically Released Brakes

Spring Set Brakes



Robotics

ERS Brakes can position and hold robotic equipment. Emergency braking in the event of power loss can prevent damage to equipment.



Medical Equipment

ERS brakes are used as parking brakes in wheelchairs and holding brakes in medical apparatus such as mammography and cat scan equipment.



Automated Material Handling Systems

ERS Brakes hold rollers and lift mechanisms in place, and lock drive wheels in place.

Overhead Door

The ERD can be used in conjunction with a photo eye. In this application, whenever the light beam is broken, voltage to the brake is removed. The brake then applies and holds the door in position. Further, the manual release feature allows the operator to open/close the door in the event of a power failure.

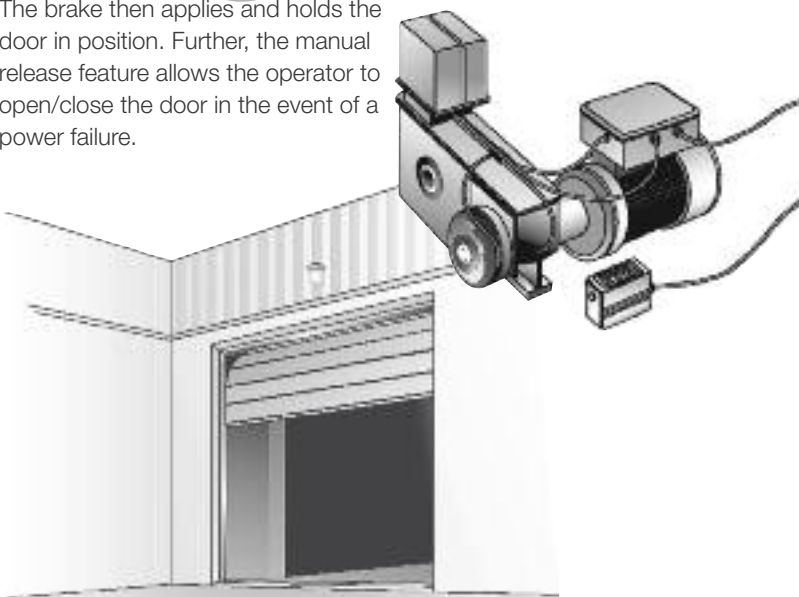

Mobile Equipment

ERS Brake, applied as a parking brake function on lift trucks, prevent rolling on slanted surfaces without the need for manual brake linkage or expensive hydraulic brakes.

ERS Series Electrically Released Brakes

For Static Holding and Emergency Stopping

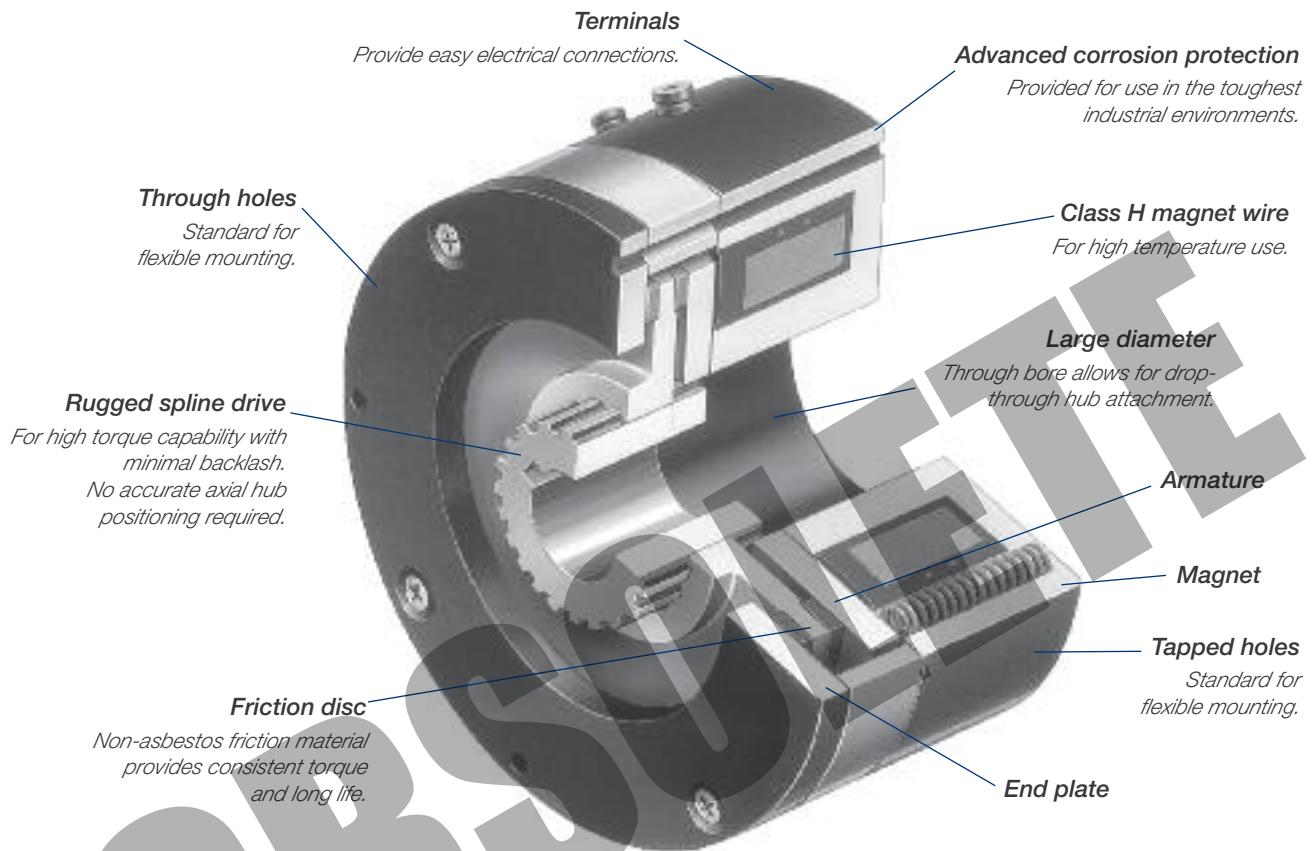

Packaged Performance

Warner Electric ERS Brakes are pre-assembled and burnished at the factory. The engineering is built-in. Each unit is checked to ensure full rated torque right out-of-the-box. Just secure the hub, bolt down the brake and wire it up. An optional AC to DC control is available for use with all 90 volt units. Unique mounting features make it easy to adapt the ERS Brake to almost any application requirement.

ERS brakes are available in NEMA C-face mounted modules. Please consult factory for assistance.

Features

- Designed for static holding operations
- Brake automatically engages when power is turned off
- Flexible mounting
- Electrically released – spring actuated
- Quick, quiet response for rapid engagement
- Compact, low profile design saves space
- Spline drive for high torque, minimal backlash and long life
- Available in five sizes. Static torque ratings from 1.5 lb.ft. to 100 lb.ft.
- UL listed – All sizes.

WARNING For general use in horizontal shaft applications only. For possible vertical applications, contact technical support.

Principle of Operation

ERS Brake torque is developed when springs apply a clamping force between the brake armature and the friction disc to the end plate. Spring clamping force provides the holding torque of the brake.

To release the brake, electrical power is applied to the magnet coil, generating a magnetic attractive force between the armature and magnet. The magnetic force overcomes the spring action, allowing the friction disc to rotate freely.

“Electrically Released” brakes are so named because, when power is removed, the brake will stop and hold a load. This occurs when power is lost either intentionally or unexpectedly due to a machine malfunction. When power is on, the brake electrically releases the load, allowing it to move freely.

ERS Series Electrically Released Brakes

Selection



Sizing

Three factors are important for proper sizing:

- Static holding torque requirement
- System inertia and brake RPM
- Stopping time

Step 1

Holding Torque

Select the size unit with torque capacity closest to, but not less than, the holding torque required.

Brake Size	Holding Torque Rating lb. ft.
ERS-26	1.5
ERS-42	7.0
ERS-49	15.0
ERS-57	34.0
ERS-68	100.0

Step 2

System Inertia/Emergency Stop

In an emergency stop (when power is interrupted), the ERS Brake will engage and bring the load to a stop. To properly size a brake for this application, load inertia must be known. This is the total inertia of all components which are to be brought to a stop. Adding the inertia of the ERS Brake is not necessary; it has been included in the selection chart.

With the load inertia and brake RPM known, use the Emergency Stop Selection Chart to verify your brake selection. Simply locate the intersection of your RPM and inertia and make sure you are not above the line for the brake you selected based on Holding Torque (Step 1). If you are above the line, select the brake designated by the next higher line.

Selection Procedure

ERS Brakes are available in five models for an optimum size to match your application requirements. Static torque capabilities range from 1.5 lb.ft. to 100 lb.ft.

The stopping function is an important consideration when deciding which brake to use. Will the brake be engaged and disengaged in a static condition (zero speed difference between the armature disc and the friction disc)? If yes, the ERS Brake is the right choice.

Will the brake be normally engaged and disengaged in a static condition with intermittent engagements dynamically? An emergency stop is a good example. If yes, the ERS Brake is the ideal choice.

Will the brake be subject to frequent dynamic braking action? If yes, then a Warner Electric ER, FB or ERD brake should be considered. The ERS Brake is not the best choice for use as a high cycle rate dynamic brake.

Emergency Stop Selection Chart

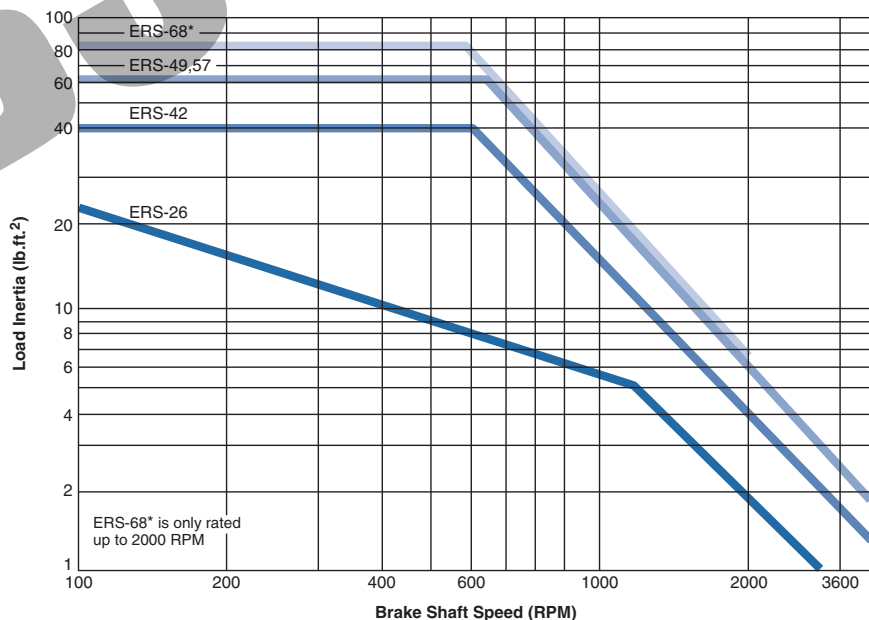

*ERS-68 is only rated up to 2000 RPM

Step 3

Stopping Time

In some applications, it is desirable to know how fast a brake will bring a load to rest. The time to stop a load can be determined if the system inertia and brake holding torque are known, according to the following equation:

$$\text{Where: } t = \frac{WR^2N}{308T}$$

t = time to stop the load in seconds (sec.)

WR² = system inertia at the brake location in pound-feet squared (lb.ft.²)

N = speed of the brake shaft in revolutions per minute (RPM)

T = rated brake holding torque in pound-feet (lb.ft.) See step 1, page 110.

Actual stopping times depend on application variables, which include brake temperature, electrical suppression (see the brake apply time data below), manufacturing tolerances, friction material wear, etc. For this reason, specific stop times should be evaluated under actual application conditions.

If your application has special requirements, please call us.

Step 4

Select Control

Consult the Controls Section for control product overview. The holding torque for an ERS is not adjustable. Therefore, an adjustable torque control is not required.

Brake Apply/Release Time (Typical Values)

Model	Brake Release Time (Seconds)		Brake Apply Time (Seconds)			
	24V	90V	Suppression Circuit A		Suppression Circuit B	
	24V	90V	24V	90V	24V	90V
ERS-26	0.03	0.03	0.04	0.04	0.01	0.01
ERS-42	0.05	0.06	0.10	0.10	0.01	0.02
ERS-49	0.07	0.08	0.15	0.15	0.02	0.02
ERS-57	0.11	0.11	0.15	0.15	0.02	0.02
ERS-68	0.16	0.20	0.20	0.20	0.03	0.03

Note: Release and Apply Times are armature engagement and release only.

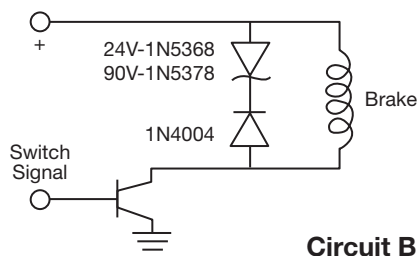
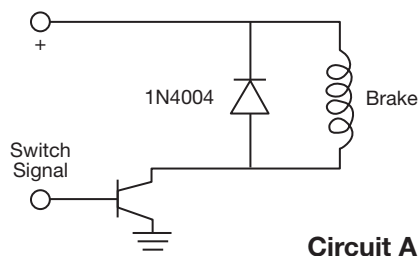

ERS Series Electrically Released Brakes

Armatures/Hubs

Armature Drives

The rugged splined drive provides flexibility in selecting the most efficient method of coupling a load to the ERS Brake. Each unit size has standard splined hubs available for common shaft sizes.

Recessed Hub

For maximum space efficiency, mount hub on shaft, then mount brake over hub.

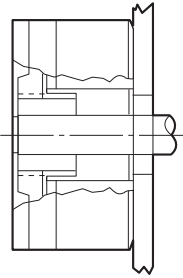

Extended Hub

Mount brake first, then position hub on shaft so hub is beyond the brake.

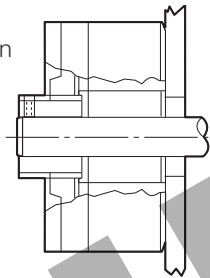

Mating Splined Member

Machined spline on drive member matches armature spline to operate brake.

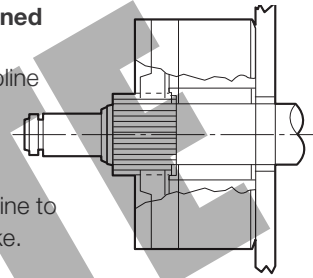

Drive Hub/Spline and Interface Data

Set Screw Orientation

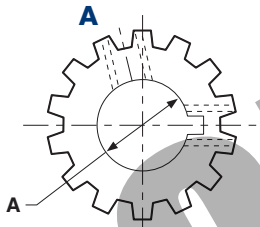

Set Screw Orientation

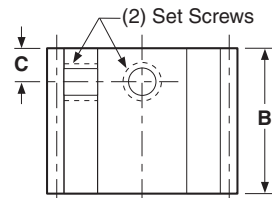
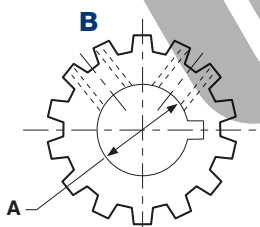

Model	A Bore	Mating Key (Not furnished)	Set screw Orientation	B Nom.	C Nom.	Set Screws	No. of Teeth	Dia. Pitch	Pressure Angle
ERS-26	.2525/.2505	1/16 x 1/16	B	.600	.135	6-32	14	20/40	30°
	.3150/.3130	1/16 x 1/16	B						
	.3775/.3755	3/32 x 3/32	B						
ERS-42	.3775/.3755	3/32 x 3/32	A	.700	.150	8-32	19	16/32	30°
	.5025/.5005	1/8 x 1/8	A						
	.6275/.6255	3/16 x 3/16	A						
	.7525/.7505	3/16 x 3/16	B						
ERS-49	.3775/.3755	3/32 x 3/32	A	.800	.160	10-32	21	16/32	30°
	.5025/.5005	1/8 x 1/8	A						
	.6275/.6255	3/16 x 3/16	A						
	.7525/.7505	3/16 x 3/16	B						
	.8775/.8755	3/16 x 3/16	B						
ERS-57	.5025/.5005	1/8 x 1/8	A	.800	.190	1/4-20	15	10/20	30°
	.6275/.6255	3/16 x 3/16	A						
	.7525/.7505	3/16 x 3/16	A						
	.8755/.8755	3/16 x 3/16	B						
	1.0025/1.0005	1/4 x 1/4	B						
ERS-68	1.0025/1.0005	1/4 x 1/4	A	.900	.190	1/4-20	22	10/20	30°
	1.1275/1.1255	1/4 x 1/4	A						
	1.2525/1.2505	1/4 x 1/4	A						
	1.3775/1.3755	5/16 x 5/16	A						
	1.5025/1.5005	3/8 x 3/8	B						

Note: Involute spline data per ANSI B92. 1a-1976, Class 5.

Backlash

Total unit backlash includes spline and armature movement. It is typically less than one degree of rotation. Spline backlash alone is typically 15 minutes of rotation or less.

ERS Series Electrically Released Brakes

Mounting

Mounting Orientation

ERS Brakes are easily modified to accommodate different mounting orientations. The brake can be mounted with either face against the mounting surface. The following mountings are possible with the standard ERS brake.

Mounting Requirements

1. Mounting surface to be perpendicular to shaft with in .006" T.I.R.
2. Mounting holes to be within .015" true position to the shaft.

Through Bolt

Provides rigid support. May be mounted on either side of brake.

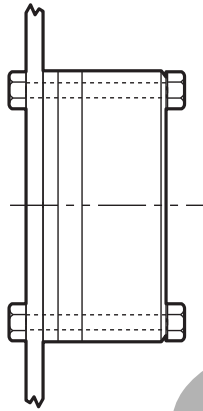

Tapped Hole

Works well where through bolt mounting is impractical.

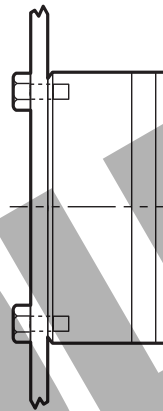

Flange

Flange mounting to brake tapped holes for most versatile attachment to many different housings, motors, and frames.

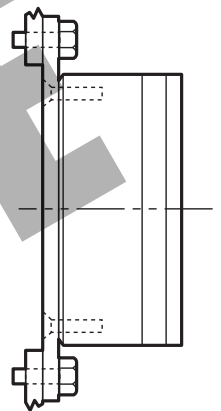

Optional Adapter Mounting Flange

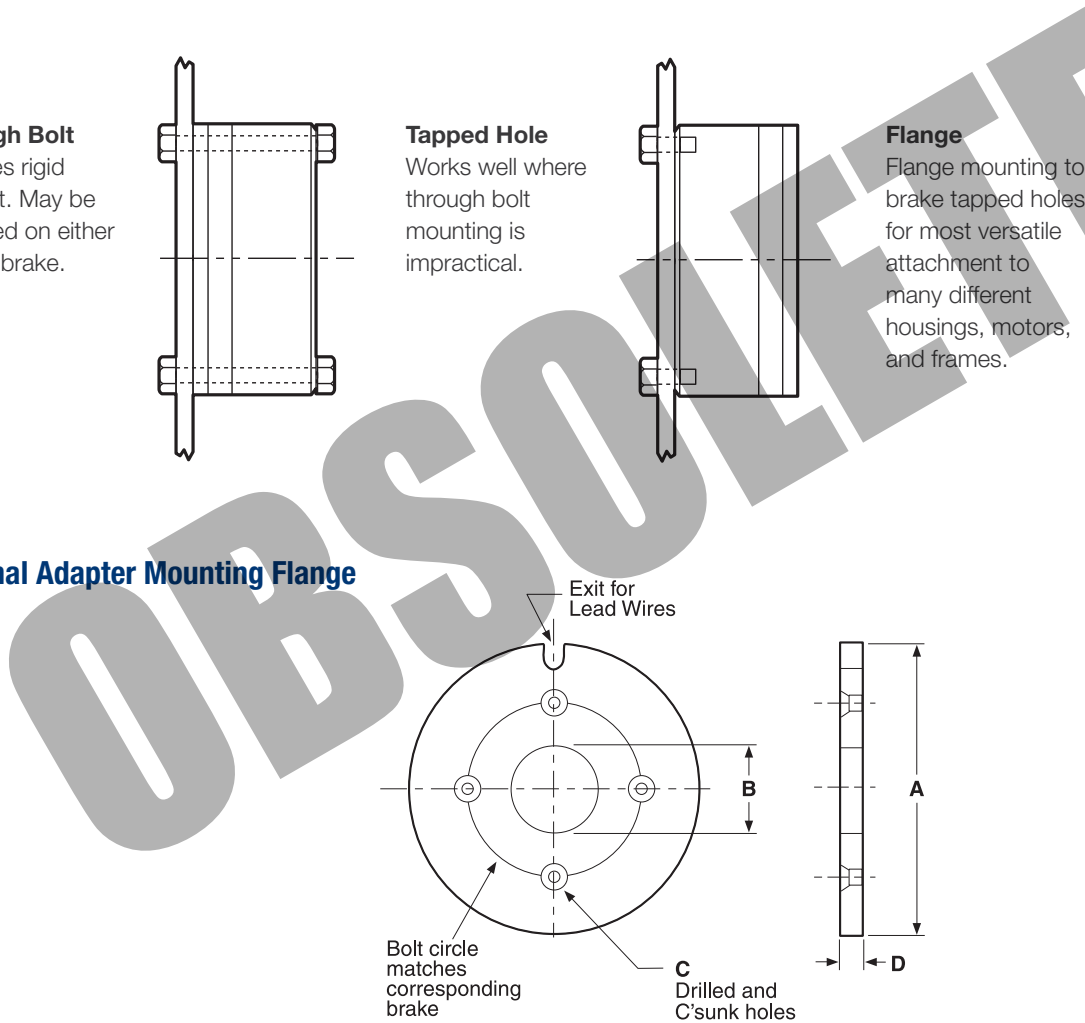

Model	A Nom.	B Nom.	C Holes	D Nom.
ERS-26	4.000	.935	#4	.100
ERS-42	5.000	1.450	#6	.144
ERS-49	6.250	1.575	#8	.193
ERS-57	7.500	1.825	#10	.193
ERS-68	9.500	2.500	1/4	.224

Note: Holes for attaching flange to mounting surface to be provided by customer.

ERS Series Electrically Released Brakes

Ordering Information

Accessories

Adapter Flanges

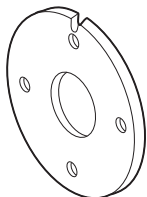

Model	Part Number
ERS-26	686-0182
ERS-42	686-0183
ERS-49	686-0184
ERS-57	686-0185
ERS-68	686-0186

Conduit Box

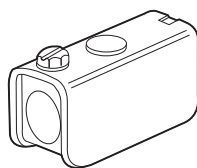

Model	Part Number
Conduit Box	5154-101-001
Mounts to ERS-49, 57 and 68 only	

Controls

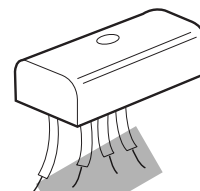

Model	Part Number
CBC-100-1	6003-448-101
AC to DC Control	
To be used with 90V ERS brakes	
See the Controls Section on page 201 for complete information.	
CBC-100-1 is 110 volt only	

Ordering Information

Ordering the appropriate ERS brake for your application is a simple, step-by-step procedure based on the intended function, brake size, mounting configuration and operating voltage of the unit best suited for your needs, including any optional parts and accessories that you may require. A Warner Electric sales representative or distributor is always happy to provide assistance.

How to Order

1. Verify that the brake is to be used in a static holding/intermittent engagement application.
2. Choose the correct size ERS Brake from the selection procedure on pages 110-111. Select the correct brake part number for the appropriate size and desired operating voltage.
3. Choose the splined hub part number for the required bore diameter and unit size.
4. Select optional accessories, such as: adapter flange kit, AC to DC control and conduit box kit.

ERS Brake

Model	Voltage	Part Number
ERS-26	24V	5158-170-016
	90V	5158-170-015
ERS-42	24V	5151-170-002
	90V	5151-170-001
ERS-49	24V	5155-170-002
	90V	5155-170-001
ERS-57	24V	5153-170-003
	90V	5153-170-002
ERS-68	24V	5154-170-002
	90V	5154-170-001

Splined Hub

Model	Bore Dia.	Part Number
ERS-26	.250	5158-541-006
	.312	5158-541-007
	.375	5158-541-008
ERS-42	.375	5151-541-002
	.500	5151-541-003
	.625	5151-541-004
ERS-49	.750	5151-541-005
	.375	5155-541-002
	.500	5155-541-003
ERS-57	.625	5155-541-004
	.750	5155-541-005
	.875	5155-541-006
ERS-68	1.000	5153-541-004
	.625	5153-541-005
	.750	5153-541-006
ERS-68	.875	5153-541-007
	1.000	5153-541-008
	1.125	5154-541-005
ERS-68	1.250	5154-541-006
	1.375	5154-541-007
	1.500	5154-541-008

Special Requirements

ERS Brake modifications such as metric bores, special voltages and low torque units are available. Consult factory.

ERS Series Electrically Released Brakes

ERS-26, ERS-42, ERS-49, ERS-57, ERS-68

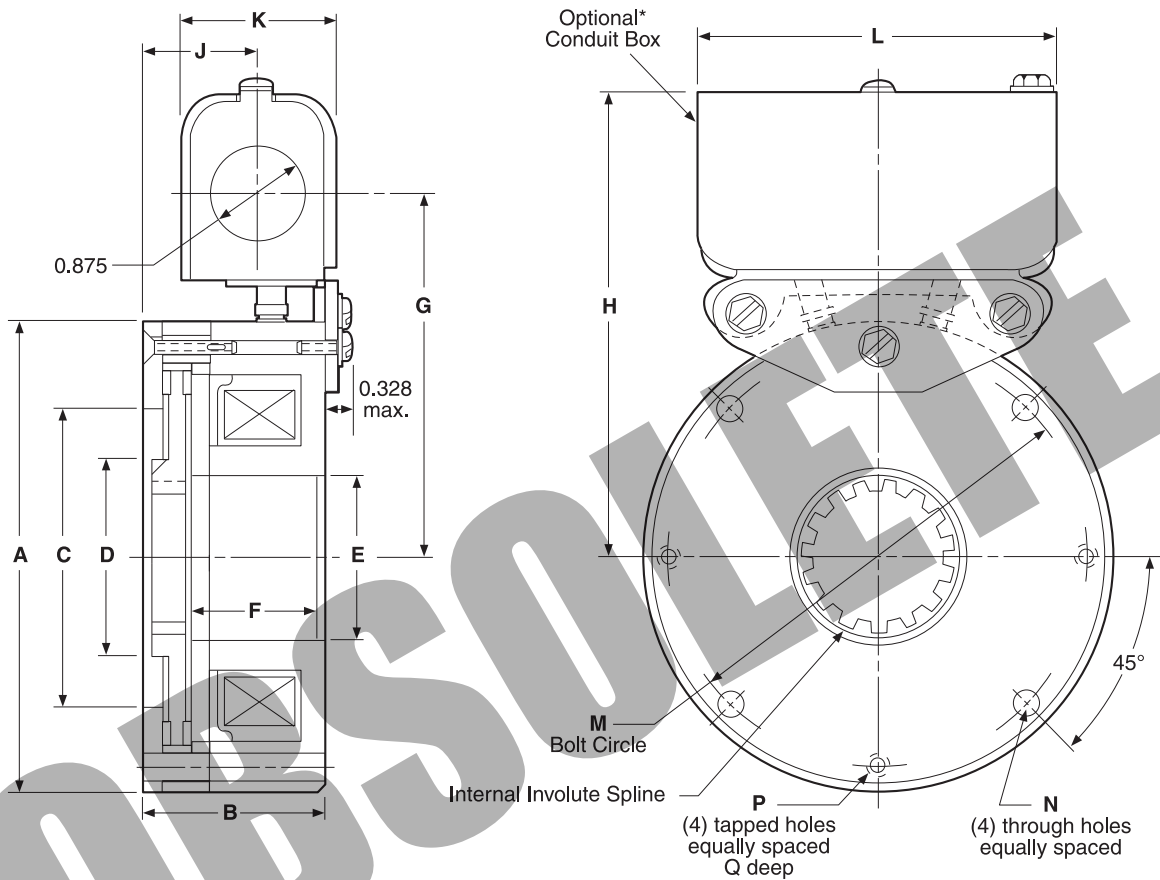

*Available only for the ERS-49, 57, and 68 sizes

ERS Series Electrically Released Brakes

ERS-26, ERS-42, ERS-49, ERS-57, ERS-68

Dimensions

All dimensions are nominal, unless otherwise noted.

Model	A Max.	B Max.	C	D	E	F	G
ERS-26	2.460	1.515	1.375	1.125	.860	1.250	—
ERS-42	3.520	1.595	2.000	1.600	1.375	1.255	—
ERS-49	4.270	1.767	2.600	1.750	1.500	1.332	3.625
ERS-57	5.020	1.937	3.240	2.100	1.750	1.503	4.000
ERS-68	6.520	2.030	4.504	2.800	2.425	1.565	4.750

Model	H	J	K	L	M Dia.	N Dia.	P	Q
ERS-26	—	—	—	—	2.125	.172/.164	4-40	.375
ERS-42	—	—	—	—	3.125	.200/.190	6-32	.400
ERS-49	4.625	1.000	1.625	3.750	3.750	.228/.218	8-32	.400
ERS-57	5.000	1.170	1.625	3.750	4.500	.288/.278	10-24	.400
ERS-68	5.750	1.265	1.625	3.750	5.875	.413/.404	1/4-20	.500

Specifications

Model	Voltage DC	Power (Watts)	Current (Amperes)	Resistance (Ohms)	Static Torque (lb.ft.)	Inertia (lb.in. ²)		Weight (lbs.)	
						Unit	Hub	Unit	Hub
ERS-26	24V	17.6	0.733	32.75	1.5	0.03	0.004	1.20	0.06
	90V	16.0	0.178	506.5					
ERS-42	24V	23.3	0.973	24.67	7	0.14	0.040	2.50	0.20
	90V	21.5	0.239	376.2					
ERS-49	24V	27.3	1.136	21.12	15	0.45	0.060	4.30	0.25
	90V	25.8	0.287	313.6					
ERS-57	24V	36.2	1.510	15.9	34	0.54	0.110	6.50	0.38
	90V	35.2	0.391	230.1					
ERS-68	24V	54.9	2.286	10.5	100	1.44	0.550	11.30	0.75
	90V	51.9	0.577	155.9					

Spring-Set Brake Modules Electrically Released Brakes

SSBM Series- EM/ERS

Packaged Spring-Set Brake Module for Holding Applications

The Spring-Set Brake Module is a NEMA C-face compatible unit designed to perform holding as well as occasional emergency stopping functions, making it particularly well-suited for motor brake applications. Because it is designed to be mounted on the front of a motor, it is an excellent choice for retrofitting an existing motor, or for use on custom designed machinery.

Features

- NEMA C-face compatible mounting
- Performs holding functions with occasional e-stops
- Completely assembled and preburnished at the factory
- Easy to install
- No adjustment required
- High torque, lead-free and asbestos-free friction material

WARNING For general use in horizontal shaft applications only. For possible vertical applications, contact technical support.

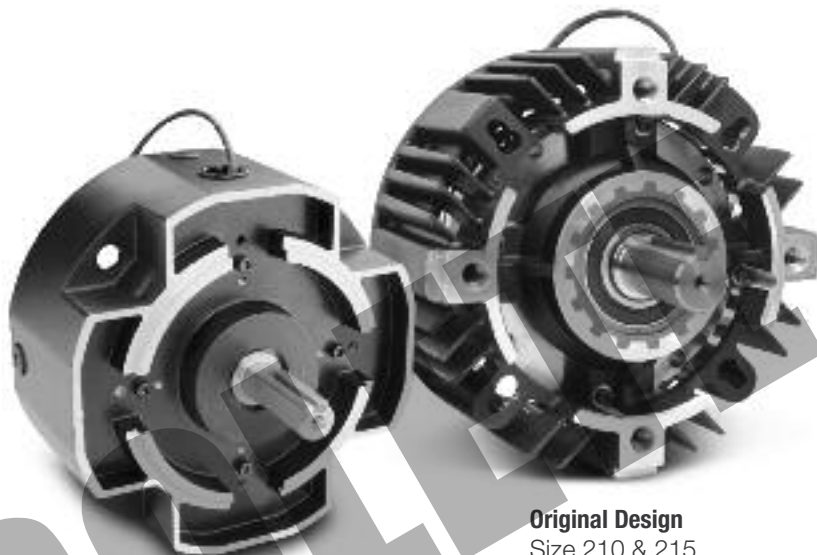

GEN 2 Design
Sizes 50 & 180

Original Design
Size 210 & 215

Principle of Operation

SSBM Brake torque is developed when springs apply a clamping force between the brake armature and the friction disc to the end plate. Spring clamping force provides the holding torque of the brake.

To release the brake, electrical power is applied to the magnet coil, generating a magnetic attractive force between the armature and magnet. The magnetic force overcomes the spring action, allowing the friction disc to rotate freely.

Specifications (Blue shaded areas indicate GEN 2 design)

Model	NEMA Frame Size	Holding Torque (ft-lbs)	Max RPM	Unit Weight (lbs)	Unit Inertia (lb-in ²)	Voltage (DC)	Power (Watts)	Current (Amperes)	Resistance (Ohms)	GEN 2 Part Number	Original Part Number
EM-50/ERS-42	56C/48Y	7.0	3600	6.4	.295	24 90	23.3 21.5	0.973 0.239	24.67 376.2	5370-170-201 5370-170-203	5370-170-122 5370-170-123
EM-50/ERS-49	56C/48Y	15.0	3600	8.2	.673	24 90	27.3 25.8	1.136 0.287	21.12 313.6	5370-170-206 5370-170-207	5370-170-124 5370-170-125
EM-180/ERS-49	143TC/145TC	15.0	3600	8.2	.673	24 90	27.3 25.8	1.136 0.287	21.12 313.6	5370-170-219 5370-170-220	
EM-180/ERS-57	143TC/145TC	34.0	3600	10.4	.955	24 90	36.2 35.2	1.510 0.391	15.90 230.1	5370-170-211 5370-170-212	5370-170-126 5370-170-127
EM-210/ERS-68	182TC/184TC	100.0	2000	24.7	3.842	24 90	54.9 51.9	2.286 0.577	10.50 156.5		5371-170-046 5371-170-047
EM-215/ERS-68	213TC/215TC	100.0	2000	24.7	3.842	24 90	54.9 51.9	2.286 0.577	10.50 156.5		5371-170-051 5371-170-052

Spring-Set Brakes Electrically Released Brakes

SSBM Series-EM/ERS

Applications

The Warner Electric Spring-Set Brake Module is an ideal holding device in applications where the motor is used to stop and accurately position the load. The SSBM brake will hold the load in that position until electrically released. The SSBM is also a cost effective emergency stopping device in the event of power failure, machine malfunction, or other occasional dynamic stopping.

Application examples include holding railroad crossing arms, basketball backboards, robotic arms, and assemblies on vertical ball screws.

Selection

SSBM Series Brakes are available in six models with static torque capabilities ranging from 7.0 lb.ft. to 100 lb.ft.

The stopping function is an important consideration when deciding which brake to use. Will the brake be engaged and disengaged in a static condition (zero speed difference between the armature disc and the friction disc)? If yes, then the SSBM Brake is the right choice.

Will the brake be normally engaged and disengaged in a static condition with intermittent engagements dynamically? An emergency stop is a good example. If yes, then the SSBM Brake is the ideal choice.

Will the brake be subject to frequent dynamic braking action? If yes, then a Warner Electric EM-FBB, EUM-FBB, EM-MBFB, EUM-MBFB, EM-FBC or UM-FBC should be considered because these are the best choices for use as high cycle rate dynamic brakes in NEMA C-face applications.

Sizing

Four factors are important for proper sizing:

- Motor frame size
- Static holding torque requirement
- System inertia and brake RPM
- Stop time

Be sure to consider each of these factors as outlined below to effectively select the most appropriate brake for your application.

1. NEMA C-face Mounting

Verify the brake is to be used in a static holding/intermittent engagement application.

Based on the NEMA C-face frame size of the prime mover, select the correct brake module size from the Frame Size Selection Chart.

Frame Size Selection Chart

NEMA Frame Size	Brake Model
56C/48Y	EM-50/ERS-42 EM-50/ERS-49
143TC/145TC	EM-180/ERS-49 EM-180/ERS-57
182TC/184TC	EM-210/ERS-68
213TC/215TC	EM-215/ERS-68

2. Holding Torque

Select the size unit with the torque capacity closest to, but not less than, the holding torque required.

Holding Torque Rating (ft.lb.)	Brake Model
7.0	EM-50/ERS-42
15.0	EM-50/ERS-49
15.0	EM-180/ERS-49
34.0	EM-180/ERS-57
100.0	EM-210/ERS-68
100.0	EM-215/ERS-68

3. System Inertia/Emergency Stop

In an emergency stop (when power is interrupted), the SSBM will engage and bring the load to a stop. To properly size a brake for this application, load inertia must be known. This is the total inertia of all components which are to be brought to a stop. Adding the inertia of the SSBM Brake is not necessary as it has been included in the selection chart.

With the load inertia and brake RPM known, use the Emergency Stop Selection Chart to verify your brake selection. Simply locate the intersection of your RPM and inertia and make sure you are not above the line for the brake you selected based on Holding Torque (Step 1). If you are above the line, select the brake designed by the next higher line.

Spring-Set Brakes Electrically Released Brakes

Emergency Stop Selection Chart

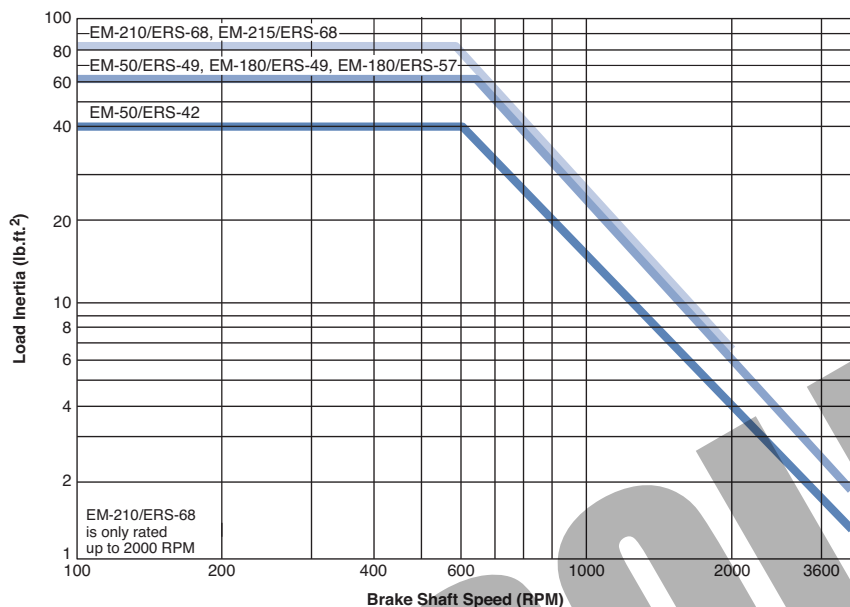

Actual stopping times depend on application variables, which include brake temperature, electrical suppression (see the brake apply time data below), manufacturing tolerances, friction material wear, etc. For this reason, specific stop times should be evaluated under actual application conditions.

If your application has special requirements, please call Warner Electric Technical Support.

5. Select Control

Consult the Controls Section on page 201 for control product overview. The holding torque for a SSBM is not adjustable; therefore, an adjustable torque control is not required.

4. Stopping Time

In some applications, it is desirable to know how fast a brake will bring a load to rest.

The time to stop a load can be determined if the system inertia and brake holding torque are known, according to the following equation:

Where: $t = (WR^2N)/(308T)$

t = time to stop the load in seconds (sec.)

WR^2 = system inertia at the brake location in pound-feet squared (ft.lb²)

N = speed of the brake shaft in revolutions per minute (RPM)

T = rated brake holding torque in foot-pounds (ft.lb.)

Special Requirements

SSBM brake modifications, such as special voltages, rear motor mounting, and low torque units are available.

Contact Warner Electric Technical Support at 800-825-9050.

Brake Apply/Release Time (Typical Values)

Model	Brake Release Time (Seconds)		Brake Apply Time (Seconds)			
	24V	90V	Suppression Circuit A		Suppression Circuit B	
			24V	90V	24V	90V
EM-50/ERS-42	0.05	0.06	0.10	0.10	0.01	0.02
EM-50/ERS-49 EM-180/ERS-49	0.07	0.08	0.15	0.15	0.02	0.02
EM-180/ERS-57	0.11	0.11	0.15	0.15	0.02	0.02
EM-210/ERS-68 EM-215/ERS-68	0.16	0.20	0.20	0.20	0.03	0.03

Note: Release and Apply Times are armature engagement and release only.

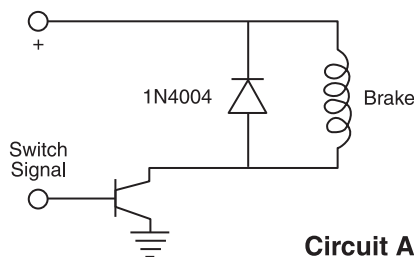

Circuit A

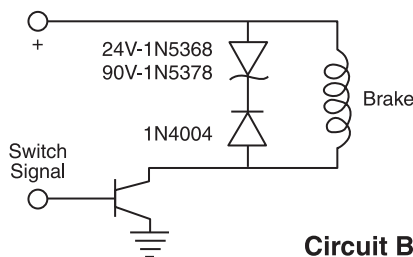

Circuit B

Spring-Set Brakes Electrically Released Brakes

SSBM Series-EM/ERS

SIZE 50/180

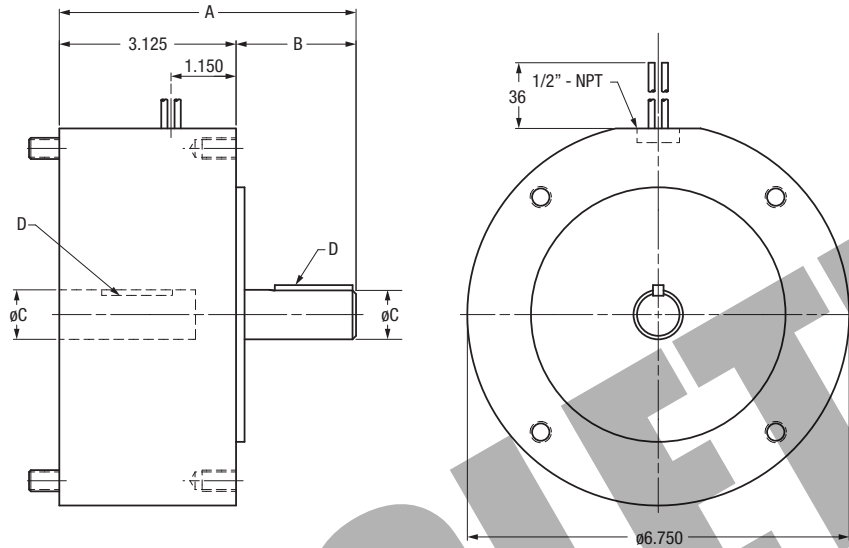

SIZE 210/215

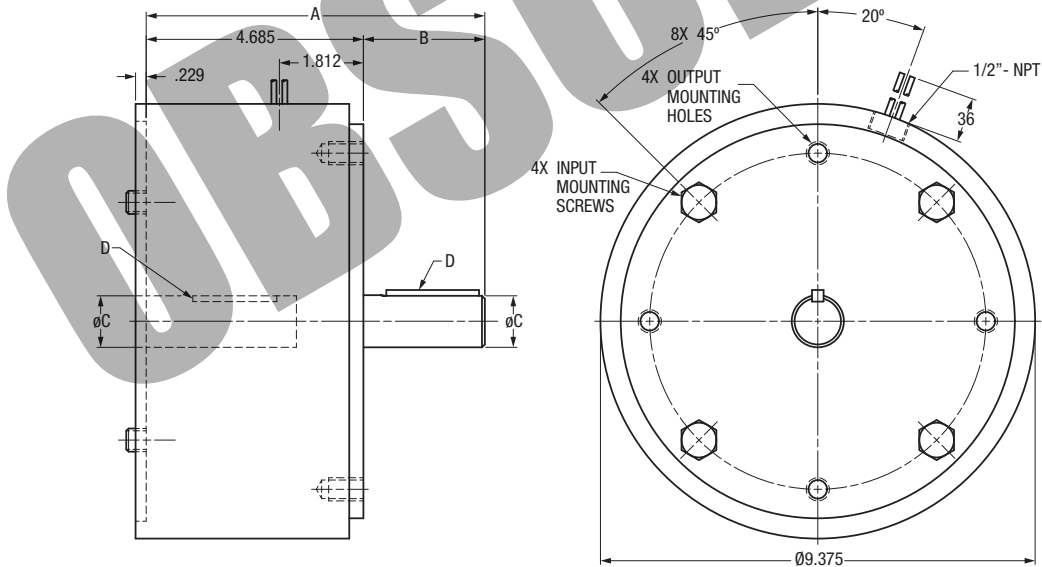

Dimensions (Blue shaded areas indicate GEN 2 design)

Size	A	B	C	D
50	5.197	2.072	.625	3/16 x 3/16
180	5.257	2.132	.875	3/16 x 3/16
210	7.304	2.619	1.125	1/4 x 1/4
215	7.804	3.119	1.375	5/16 x 5/16

For standard NEMA frame dimensions, see page 187.

Only 50 and 180 sizes of the models listed will be converted to the new GEN 2 design.
210 and 215 size will continue to be offered in the original design and will not be converted.

ERD Series Electrically Released Brakes

The Inside Story

Continuous duty coil is epoxy-sealed; windings have Class F insulation. Lead wires have standard Class B insulation rating on sizes 005–035. Sizes 060–300 have Class F rating.

Central Torque Adjustment (VAR 02) allows braking torque adjustment down to 50% of nominal rating; ideal for controlling stopping distances.

Compression Springs are used to provide balanced armature plate loading.

Friction Disc has double friction surfaces for increased torque in small package size.

Splined Center Hub is steel for wear resistance and available in a variety of bore sizes and keyways.

Friction Flange can easily be modified to suit unique bolt patterns. In special cases, brakes may be mounted directly to the motor without the need for the flange.

Air Gap is factory pre-set and easy to adjust during field maintenance.

ERD Series brakes are designed to safely keep the load in position in the event of a power or motor failure, whether intentional or accidental.

By applying voltage to the ERD, an electromagnetic field is created which causes the armature plate to pull-in against helical compression springs, thus releasing the brake. When power is removed, the springs force the armature to compress the friction carrier against the mounting flange, thus stopping and holding the load. Fully dynamic friction material on the carrier allows for repeated braking cycles from full motor speed with no torque fade.

An optional manual release allows the operator to safely move the load even when no power is available.

Brakes are available in eight different sizes ranging from 3.3 inches to 9.9 inches in diameter with torque capacities from 4 to 220 lb.ft.

Features/Benefits

- Dynamic friction material can stop loads from motor speeds up to 3600 RPM.
- Few moving parts means quiet operation.
- Lead and asbestos free, dynamic friction material is suited for high cycle rates.
- Variety of voltages available.
- Simple DC control (or AC with available rectifiers).
- Low power requirements for energy savings.
- Bi-directional stopping capability.
- Epoxy encapsulated coil for uniform heat transfer.
- Corrosion resistant.
- Low inertia rotating parts.
- Splined hub for quiet dependable operation.
- Metric and inch standard bore sizes.

WARNING For general use in horizontal shaft applications only. For possible vertical applications, contact technical support.

ERD Series Electrically Released Brakes

Applications

As a fail-safe, power-off brake, the ERD family is ideally suited for such load-stopping and holding applications as:

- Conveyors
- Machine Tools
- Robotics
- Medical X-Y Positioning
- Scooters
- Floor Sweepers/Cleaners
- Motor Brakes
- Overhead Doors
- Hoist/Winch
- Fork Lift

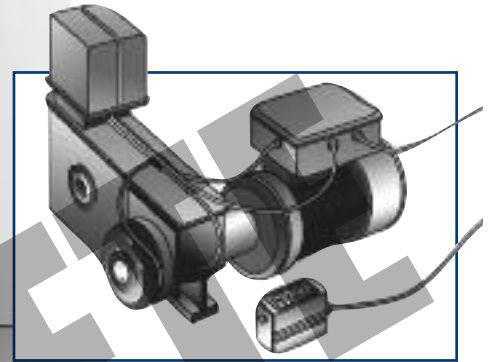
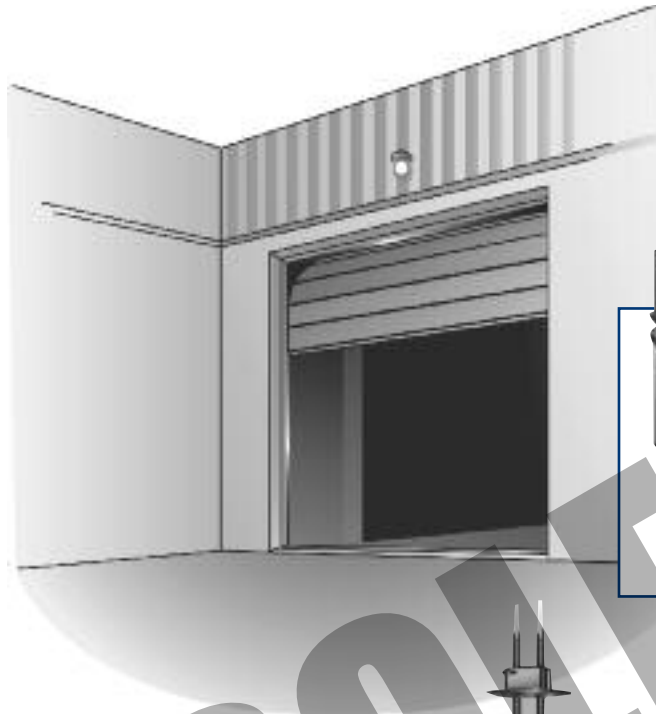

Overhead Door

The ERD can be used in conjunction with a photo eye. In this application, whenever the light beam is broken, voltage to the brake is removed. The brake then applies and holds the door in position. Further, the manual release feature allows the operator to open/close the door in the event of a power failure.

Hoist/Winch

The ERD with central torque adjustment can be used to consistently stop the rated load within a fixed distance by dialing-in the proper torque level on each production hoist. The addition of a manual release allows the load to be gradually and safely lowered to the ground in the event of power failure.

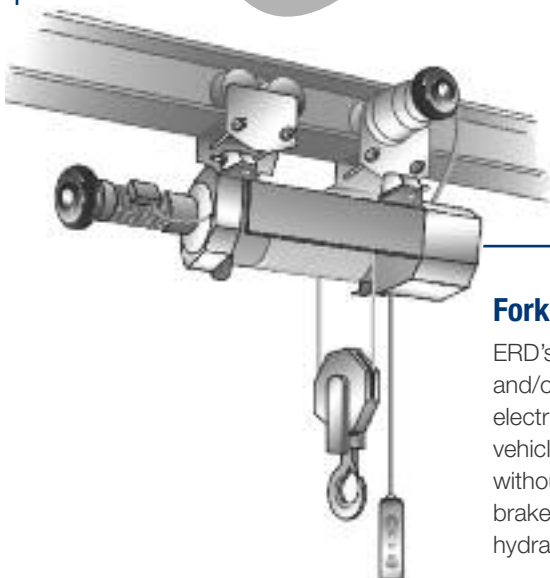
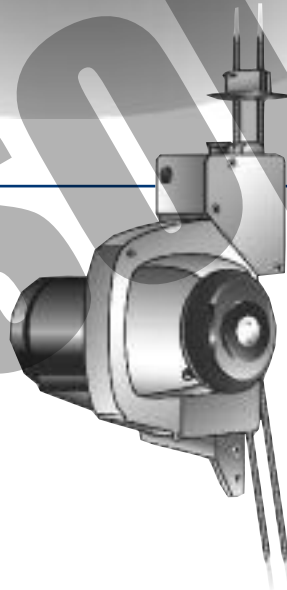

Fork Lift

ERD's are used as safety and/or parking brakes on electric fork trucks to hold the vehicle on inclines etc. without the need for manual brake linkage or expensive hydraulic brakes.

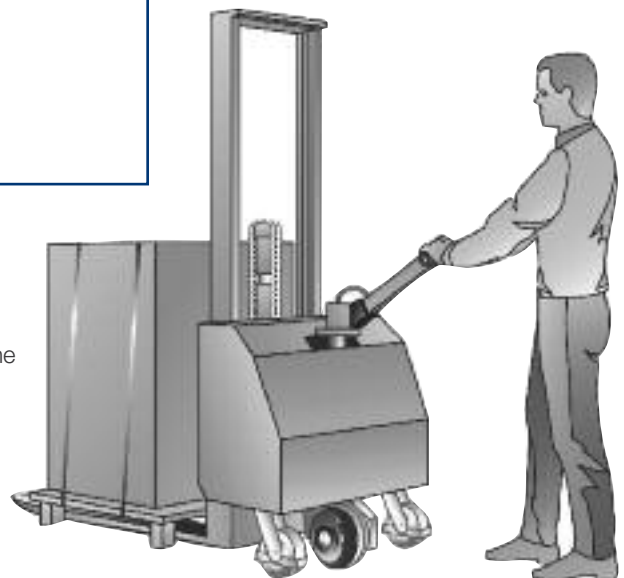

ERD Series Electrically Released Brakes

Selection Procedure

Proper fail-safe brake selection involves determining, in order:

1. Static Holding Torque

The ERD brake nominal holding torque should exceed the torque from the load by a minimum safety factor of 2.0.

2. Dynamic Torque

This is determined from the equation:

$$T = \frac{5250 P K}{N}$$

where:

- T = Dynamic Torque, ft.lb.
- N = Motor Speed, RPM
- P = Motor Horsepower
- K = Momentary Peak Torque Factor (Typically 2.5)

Once the dynamic torque has been calculated, check the dynamic torque curves (to the right) at the required operating speed to determine the suitable brake.

3. Energy Capacity (Heat Dissipation)

Sizing of the ERD by energy capacity is a function of the cycling frequency (cycles per hour) and the single cycle energy put into the brake as determined from the equation:

$$E = 1.7 WR^2 \left(\frac{N}{100} \right)^2$$

where:

- E = Single Cycle Energy, ft.lb.
- WR² = Load Inertia, lb.ft²
- N = Speed, RPM

Applying the energy per cycle with the cycle rate to the energy curve, the brake selection is verified.

Dynamic Torque

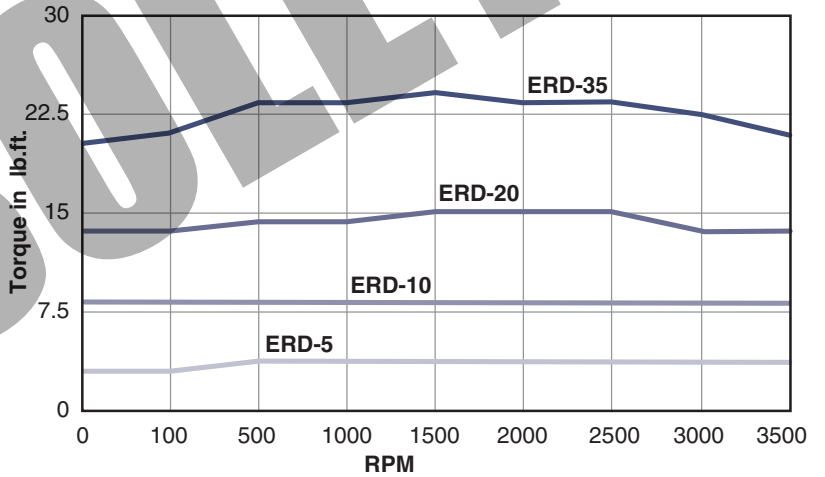
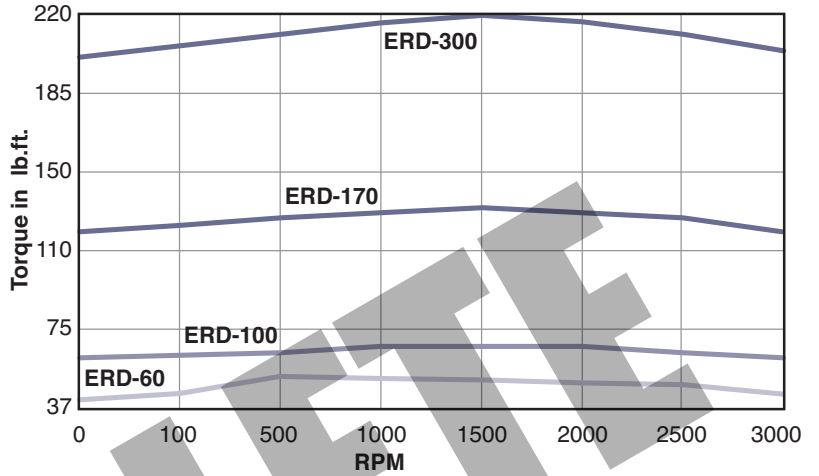

Energy Capacity (Heat Dissipation)

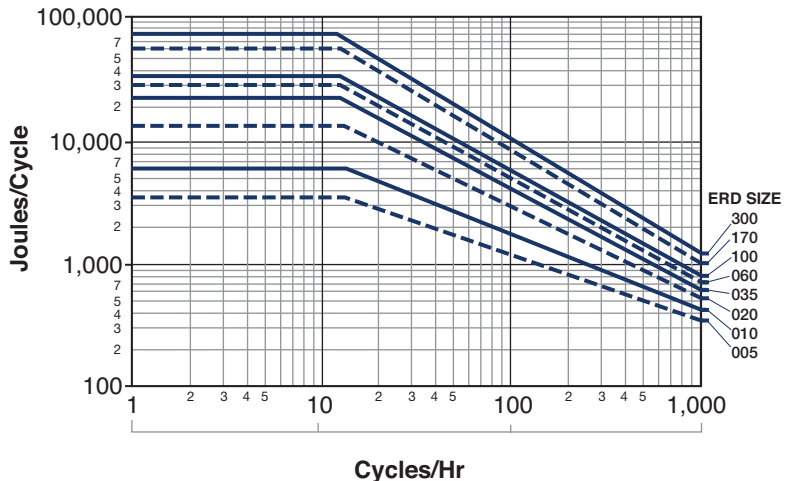

Note: To convert Joules/min. to ft.lbs./min, multiply times .7376

ERD Series Electrically Released Bakes

Specifications

	Options	Units	ERD 5	ERD 10	ERD 20	ERD 35	ERD 60	ERD 100	ERD 170	ERD 300
Holding Torque		in.lb.	45	85	175	310	530	890	1500	2650
		ft.lb.	4	7	15	26	44	75	125	221
Maximum Speed		RPM	3600	3600	3600	3600	3600	3600	3600	3600
Rotating Inertia	S	lb.in. ²	0.041	0.137						
	M	lb.in. ²	0.103	0.321	0.957	2.529	7.415	12.472	14.010	29.386
Current Draw		Amps								
	24 VDC		0.83	1.03	1.22	1.61	1.94	2.35	2.73	4.11
	103.5 VDC*		0.21	0.26	0.31	0.41	0.49	0.57	0.69	1.122
	207 VDC*		0.09	0.12	0.14	0.18				
Resistance at Ambient Temperature	24 VDC	Ohms	28.9	23.4	19.6	14.9	12.4	10.22	8.78	5.83
	103.5 VDC*		454	372	310	233	166.2	168.6	139.2	85.63
	207 VDC*		2380	1813	1545	1175				
Weight		lbs	2	4	7	10	14	22	34	57

* The controls designed on pages 130 and 131 provide output voltages to operate these brakes.

Ordering Procedure

Specify:

- Size: upon sizing criteria, select a size.
5, 10, 20, 35, 60, 100, 170, or 300
- Variation:
0 – No torque adjustment
2 – With central torque adjusting ring
- Friction Disc:
Metallic carrier is standard.
Thermoplastic carrier is available on sizes 5 & 10.
High torque carrier available on sizes 060 through 300.
- Options:
Dust Cover
Manual Release
- Friction Flange & Mounting Screws:
Thick Flange is standard – Requires Short Screws.
Intermediate Flange available up to Size 35 – Requires Long Screws.
No Mounting Flange is an option – Requires Long Screws.
- Voltage:
24 DC is standard.
103.5 (90)* & 207/215* DC are modifications.
- Bore Size:
Pilot bored hubs available in all sizes.
See table for US-English and Metric bore sizes available by ERD size.
Special bores available on request.
- Detection Kit – Micro Switch
For Service Manual, request catalog P-229. This option not retrofittable. Requires a 25 piece minimum order for sizes 005 thru 035.

Caution:

These units are designed for dry operation. The brake must be free from oil and grease. Exceeding the maximum rotation speed listed in the catalog will invalidate the guarantee.

* Coil voltages can vary slightly depending on unit size.

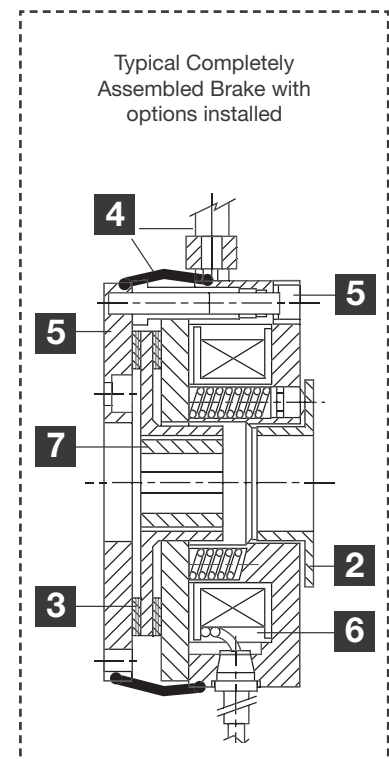

ERD Series Electrically Released Brakes

Product Configuration

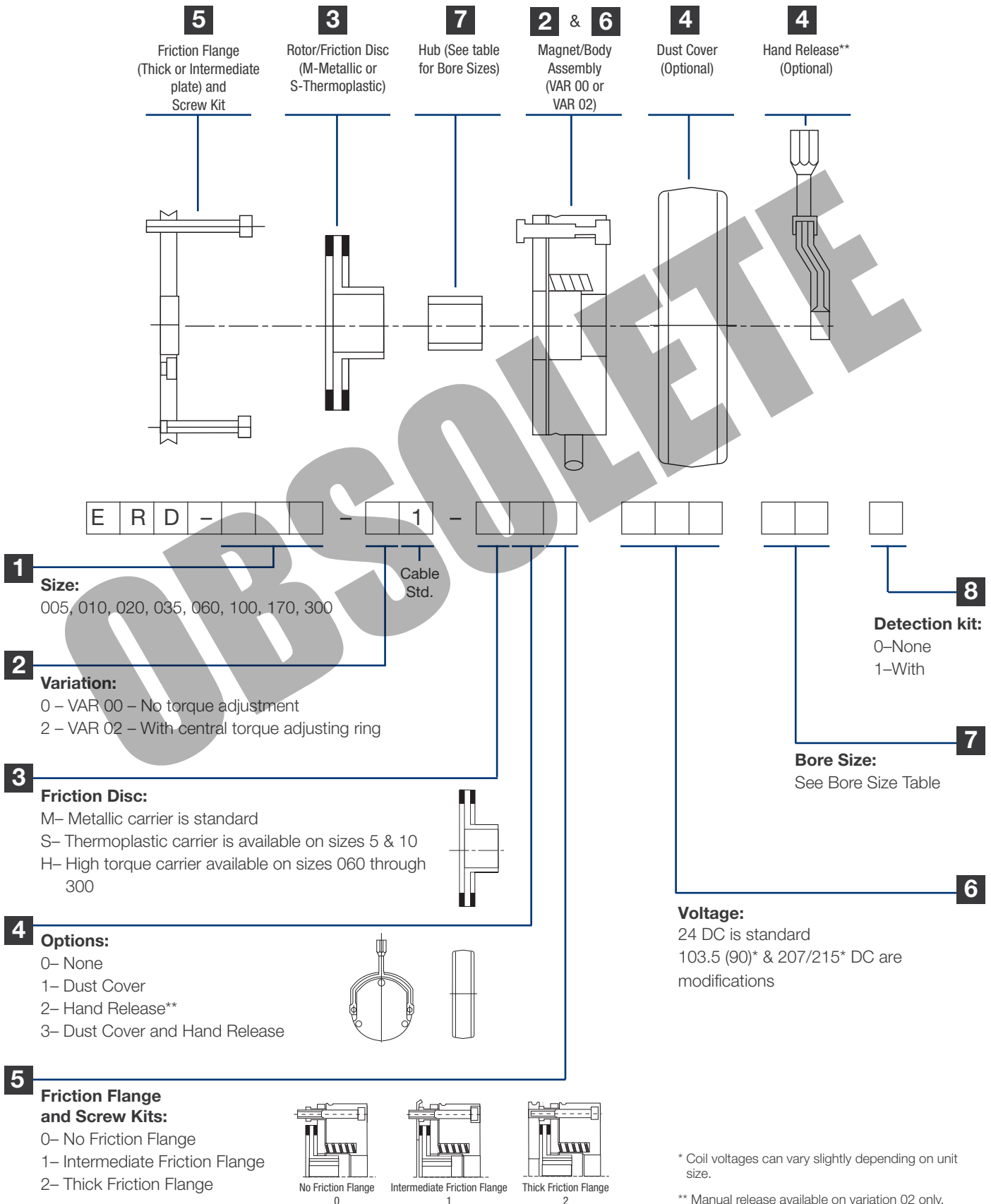

ERD Series Electrically Released Bakes

4 Mounting Options (by customer)

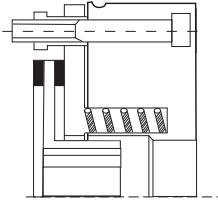

No Friction Flange
Requires long screw kit

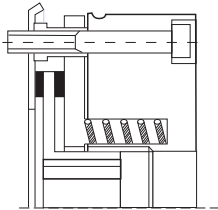

Intermediate Friction Flange
Requires long screw kit
Available on sizes 005 thru 035 only.

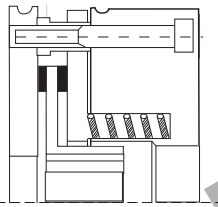

Thick Friction Flange (Standard)
Requires short screw kit

2 Magnet Assembly Variations

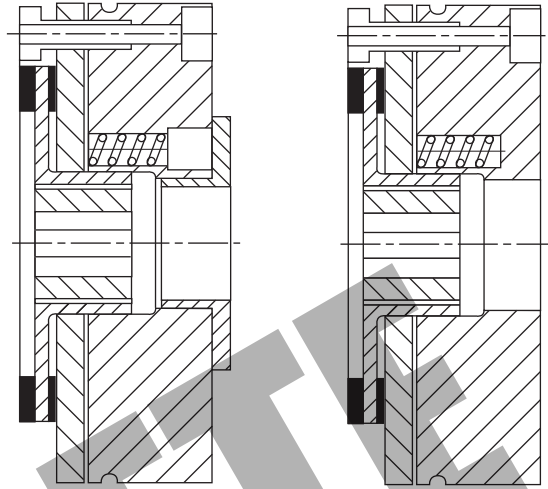

VAR 02

- Torque reduction up to 50% by loosening one nut.
- Available in all sizes.
- Central nut has several "Detents" per turn allowing accurate torque adjustment.
- The brake is factory set at the minimum torque (50% of max. torque).

VAR 00

- No torque adjustment possible
- Available in all sizes.
- No hand release option available.

3 Rotor/Friction Disc

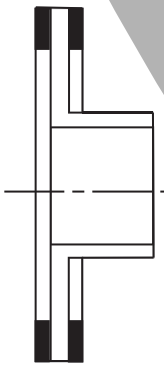

Available in two styles
M – Metallic (Standard)
S – Thermoplastic (Low inertia)
Sizes 005 & 010 only

- Large thermoplastic bore hubs (Available in sizes 005 and 010 only)
- Large bore metallic disc (Available in sizes 005 thru 035)
- High torque metallic discs (Available in sizes 060 thru 300. Requires lower speed of rotation.)

7 Hub

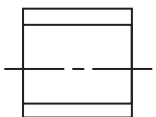

See Table for hub, bore and keyway size availability by ERD size.

4 Manual Release (Optional)

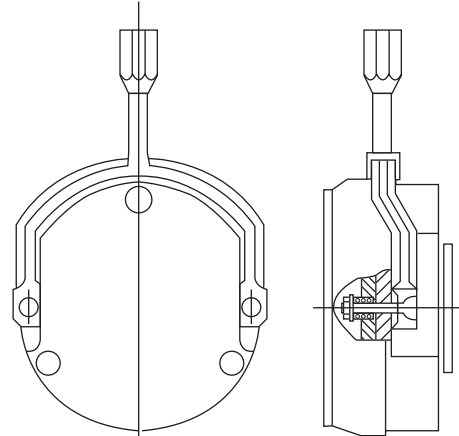

Automatically returns to "neutral position" when released, thereby restoring holding torque to the brake.

Designed to be retrofitted, except to VAR 00.

4 Dust Cover (Optional)

Available in all sizes.



ERD Series Electrically Released Brakes

Brakes

VAR 02

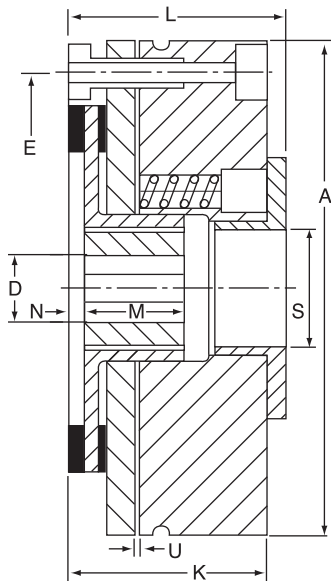

Dimensions

All dimensions are nominal, unless otherwise noted.

ERD Size	A	D Max.	E	K	L Max.	M +0.000/-0.008
5	3.307 (84)	0.5 (12)	2.835 (72)	1.378 (35)	1.575 (40)	0.709 (18)
10	4.016 (102)	0.625 (15)	3.543 (90)	1.614 (41)	1.831 (46.5)	0.787 (20)
20	5.000 (127)	1.0 (24)	4.409 (112)	1.870 (47.5)	2.185 (55.5)	0.787 (20)
35	5.787 (147)	1.125 (28)	5.197 (132)	2.146 (54.5)	2.559 (65)	0.984 (25)
60	6.378 (162)	1.25 (32)	5.709 (145)	2.520 (64)	2.933 (74.5)	1.181 (30)
100	7.402 (188)	1.500 (41)	6.693 (170)	2.795 (71)	3.209 (81.5)	1.181 (30)
170	8.465 (215)	1.95 (50)	7.717 (196)	3.268 (83)	3.780 (96)	1.378 (35)
300	9.921 (252)	2.125 (54)	9.055 (230)	3.819 (97)	4.528 (115)	1.575 (40)

VAR 00

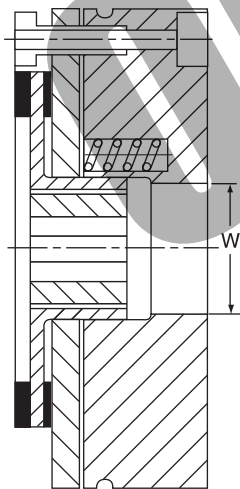

ERD Size	N	S	U +/-0.002	W
5	0.079 (2)	0.748 (19)	0.008 (0.2)	0.925 (23.5)
10	0.118 (3)	0.945 (24)	0.008 (0.2)	1.122 (28.5)
20	0.157 (4)	1.378 (35)	0.008 (0.2)	1.594 (40.5)
35	0.118 (3)	1.575 (40)	0.012 (0.3)	1.909 (48.5)
60	0.118 (3)	1.890 (48)	0.012 (0.3)	2.303 (58.5)
100	0.118 (3)	2.047 (52)	0.012 (0.3)	2.500 (63.5)
170	0.177 (4.5)	2.362 (60)	0.012 (0.3)	2.894 (73.5)
300	0.197 (5)	2.874 (73)	0.012 (0.3)	3.484 (88.5)

1. Concentricity of field mounting pilot diameter with rotor mounting shaft within .006 T.I.R.
2. Squareness of field mounting face with rotor mounting shaft within .006 T.I.R. measured at field mounting bolt circle.
3. Rotor mounting shaft concentric with armature center of rotation within .006 T.I.R.
4. Armature hub pilot diameter to be concentric with armature center of rotation within .010 T.I.R.
5. If customer does not use a friction flange, the mating surface must be square to their mounting shaft within .006" and flat within .002".

ERD Series Electrically Released Bakes

Friction Plates

Thick friction plate

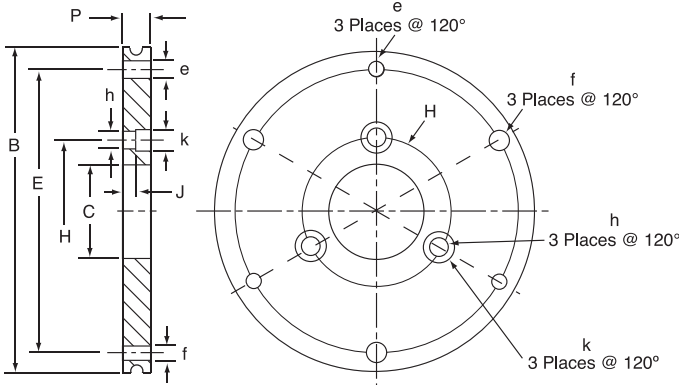

Intermediate friction plate

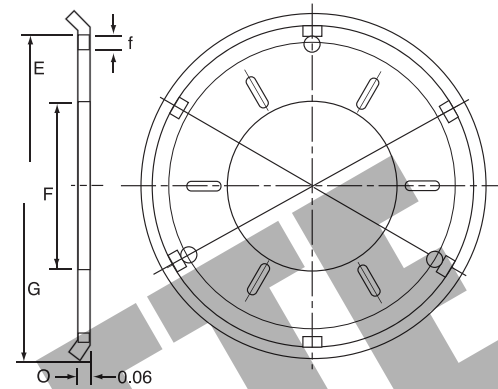

Dimensions

All dimensions are nominal, unless otherwise noted.

ERD Size	B	C	E	e Bolt Pattern	f Bolt Clearance Holes	F	G	H	h	k Bolt Clearance Holes	J	P	O
5	3.268 (83)	0.787 (20)	2.835 (72)	3xM4	3x0.177 3(4.5)	1.654 (42)	3.425 (87)	1.181 (30)	3x0.177 (4.5)	3x0.315 (8)	0.079 (2)		0.125 (3.2)
10	3.937 (100)	1.181 (30)	3.543 (90)	3xM5	3x0.217 3(5.5)	2.126 (54)	4.213 (107)	1.772 (45)	3x0.217 (5.5)	3x0.394 (10)	0.079 (2)		0.125 (3.2)
20	4.921 (125)	1.575 (40)	4.409 (112)	3xM6	3x0.256 3(6.5)	2.362 (60)	5.217 (132.5)	2.205 (56)	3x0.260 (6.5)	3x0.433 (11)	0.118 (3)		0.141 (3.6)
35	5.709 (145)	1.772 (45)	5.197 (132)	3xM6	3x0.256 3(6.5)	2.755 (70)	6.004 (152.5)	2.441 (62)	3x0.260 (6.5)	3x0.433 (11)	0.118 (3)		0.181 (4.6)
60	6.299 (160)	2.165 (55)	5.709 (145)	3xM8	3x0.335 3(8.3)			2.913 (74)	3x0.327 (8.3)	3x0.551 (14)	0.118 (3)	0.433 (11)	
100	7.283 (185)	2.559 (65)	6.693 (170)	3xM8	3x0.335 3(8.3)			3.307 (84)	3x0.327 (8.3)	3x0.551 (14)	0.118 (3)	0.433 (11)	
170	8.346 (212)	2.953 (75)	7.717 (196)	6xM8	6x0.335 6(8.3)			3.937 (100)	3x0.327 (8.3)	6x0.551 (14)	0.118 (3)	0.433 (11)	
300	9.843 (250)	3.543 (90)	9.055 (230)	6xM10	6x0.413 6(10.3)			4.724 (120)	3x0.406 (10.3)	6x0.670 (17)	0.118 (3)	0.433 (11)	

The thick mounting flange provides the proper material and mounting tolerances for the brake. The intermediate mounting flange provides the proper material in applications where flatness, squareness and concentricity requirements are met on the machine already.

Manual Release

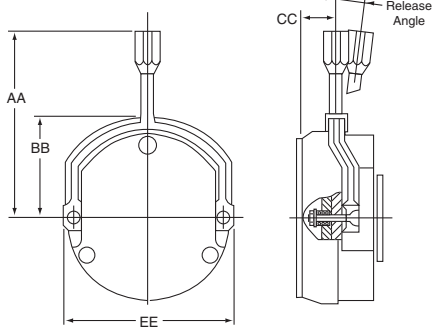

ERD Size	AA	BB	CC	DD	EE	Release Angle
5	3.86 (98)	2.09 (53)	0.67 (17)	3.46 (88)	3.46 (88)	10°
10	4.21 (107)	2.44 (62)	0.71 (18)	4.17 (106)	4.17 (106)	9°
20	5.08 (129)	2.99 (76)	0.98 (25)	5.20 (132)	5.20 (132)	8°
35	5.47 (139)	3.39 (86)	0.87 (22)	5.98 (152)	5.98 (152)	8°
60	7.44 (189)	4.09 (104)	1.57 (40)	6.53 (166)	6.54 (166)	15°
100	8.07 (205)	4.72 (120)	1.73 (44)	7.56 (192)	7.36 (187)	15°
170	9.45 (240)	5.51 (140)	2.09 (53)	8.62 (219)	8.78 (228)	15°
300	12.32 (313)	6.38 (162)	2.40 (61)	10.8 (256)	10.33 (262.5)	20°

Dust Cover



ERD Series Electrically Released Brakes

How To Order

Hub Bore and Keyway Sizes

U.S. English

Bore in.	Keyway		Available Bores							
	Width	Depth	5	10	20	35	60	100	170	300
3/8	3/32	3/64	Std.							
1/2	1/8	1/16	*	Std.	Std.					
5/8	3/16	3/32	*(Max.)	*	Std.	Std.	Std.	Std.		
3/4	3/16	3/32		*(Max.)	Std.	Std.				
7/8	3/16	3/32			Std.(Max.)	Std.			Std.	
1	1/4	1/8			*(Max.)	Std.	Std.	Std.	Std.	Std.
1-3/8	5/16	5/32				*(1-1/8Max.)		Std.	Std.	Std.
1-3/4	3/8	3/16							Std.	Std.

Metric

Bore (mm)	Keyway		Available Bores							
	Width	Depth	5	10	20	35	60	100	170	300
8			P.B.							
10			Std.	P.B.	P.B.					
11	4	2	Std.	Std.	Std.					
14	5	2.5	*	Std.	Std.	P.B.	P.B.			
15	5	2.5	*		Std.	Std.		P.B.		
18				*	Std.	Std.				
20	6	3		*(20Max.)	Std.	Std.			P.B.	
22	6	3			Std.	Std.				
24	8				*	Std.				
25	8	3.5				Std.	Std.	Std.		P.B.
28	8	3.5			*(28Max.)	*				
30	8	3.5				*(32Max.)	Std.	Std.		
35	10	4					(32Max.)	Std.	Std.	Std.
40	12	4						Max.	Std.	Std.
45	14	4.5							Std.	Std.
50	14	4.5							Max.	(54 Max.)

P.B. = Pilot Bore, * = Large Bore Hub, which requires use of a large bore friction disc.

Design Considerations/Limitations

1. Check the airgap periodically and reset as required per instructions found on page 4 of the service manual P-229. Inspection interval(s) depend on the frequency of brake application.
2. Check friction material thickness periodically per dimension N (see page 127) and replace when below the minimum shown below.

Inches (mm) millimeters

ERD Size	5	10	20	35	60	100	170	300
Min. Thickness	0.009 (0.22)	0.008 (0.21)	0.012 (0.31)	0.009 (0.22)	0.010 (0.24)	0.010 (0.24)	0.012 (0.31)	0.013 (0.32)

ERD Control Units

Dimensions

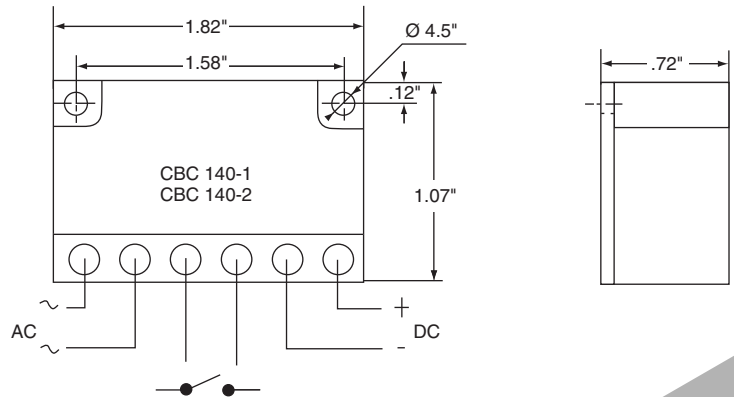

Specifications

	CBC-141-1	CBC-141-2
Part Number	ACG830A1P1	ACG830A1P2
Frequency (Hz)	50/60	50/60
Input Voltage	230 VAC	30 115 230
Output Voltage	103.5 VDC	24 103.5 207
Max. Current (A)	1	2 2 2

CBC-141-1: Supply unit with single wave rectification for low current.
 CBC-141-2: Supply unit with dual wave rectification for low current.

Dimensions

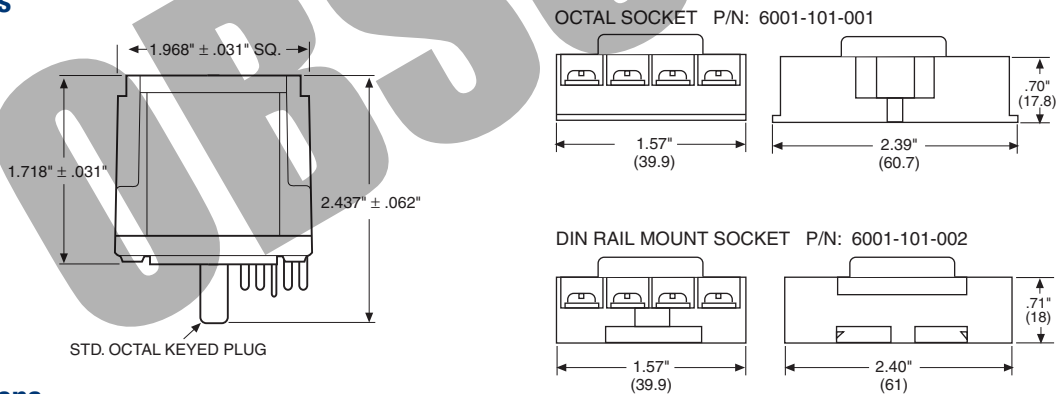

Specifications

	CBC-801-1	CBC-801-2
Part No.	6001-448-004	6001-448-006
Input Voltage	120 VAC, 50/60 Hz	220/240 VAC, 50/60 Hz
Output Voltage	90 VDC, 1.25 A max.	90 VDC, 1.25 A max.
Circuit Protection	Fused 1.6 Amp, 250 V fast-blo	Fused 1.6 Amp, 250 V fast-blo
Ambient Temperature	-23° to 116°F (-31° to 47°C)	
Max. Cycle Rate	Limited by the clutch or brake, variable with application	
Switching	Single pole, double throw Minimum contact rating: 10 Amp, 28 VDC resistive or 10 Amp, 120 VAC inductive	
Status Indicator	Red LED indicates brake is energized, Green LED indicates clutch is energized	
Mounting	Two versions of octal socket are available: 6001-101-001 foot mount 6001-101-002 DIN rail mount	

All dimensions nominal unless otherwise specified.

Dimensions

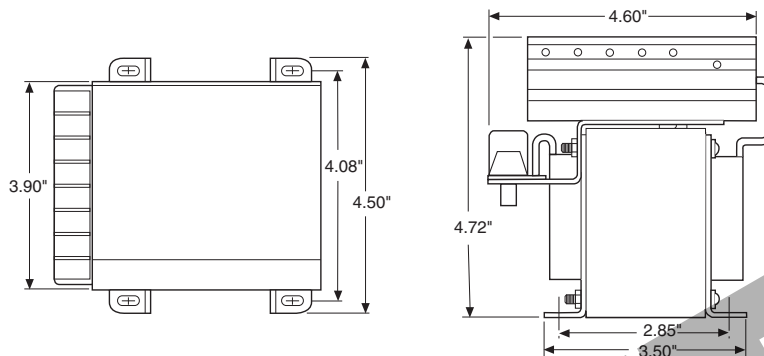

Specifications

	CBC-450-90	CBC-450-24
Part No.	6006-448-006	6006-448-005
Input Voltage	120/220/240/380/480 VAC	120/220/240/380/480 VAC
Output Voltage	90 VDC	24 VDC
Output Current	1 Amp/Channel 1.2 Amps Total	4 Amps/Channel 4 Amps Total
Auxiliary Supply	12 VDC 250 mA	12 VDC 250 mA
Circuit Protection	Fused 1.5 Amp	Fused 5 Amp
Ambient Temperature	+32° to 122°F (0° to 50°C)	+32° to 122°F (0° to 50°C)
Status Indicators	Red LED indicates channel is energized.	Red LED indicates channel is energized.
Adjustments	Jumper for single or dual operation.	Jumper for single or dual operation.
Inputs	3 Optically isolated, 10-30 VDC, 3-9 mA for Channel 1, Channel 2 and Channel 2 override (E-stop).	3 Optically isolated, 10-30 VDC, 3-9 mA for Channel 1, Channel 2 and Channel 2 override (E-stop).

ERD Series Electrically Released Brakes

1 ERD005

Description	Part Number
2 & 6 Variation 00 – 24 VDC	G5UE005A01P1
Variation 00 – 103.5 VDC	G5UE005A01P2
Variation 00 – 207 VDC	G5UE005A01P3
Variation 02 – 24 VDC	G5UE005A21P1
Variation 02 – 103.5 VDC	G5UE005A21P2
Variation 02 – 207 VDC	G5UE005A21P3
3 Friction Disc	
Standard Synthetic Disc	A5UE005B1P1
Large Bore Synthetic Disc	A5UE005B3P1
Standard Metallic Disc	A5UE005B9P1
Large Bore Metallic Disc	A5UE005B8P1
4 Options	
Hand Release	A5UE005K1P1
Dust Cover	A5UE005C4P1
5 Friction Flange & Screw Kit	
Intermediate Flange	A5UE005C309P2
Thick Flange	A5UE005C301P1
Short Screw	A5UE005K2P1
Long Screw	A5UE005K2P2
7 Hub Bore size	
Hub Pilot Bore – 8MM	A5UE005C500P1
Hub Bored W/Keyway – 11MM	A5UE005C500P2
Hub Bored W/Keyway – 10MM	A5UE005C500P5
Hub Bored W/O Keyway – 10MM	A5UE005C500P6
Hub Bored W/Keyway – 3/8"	A5UE005C500P9
Large Bore Hub W/Keyway – 1/2"	A5UE005C503P6
Large Bore Hub W/Keyway – 5/8"	A5UE005C503P5
8 Detection Kit	V4NST7

1 ERD010

Description	Part Number
2 & 6 Variation-00 – 24 VDC	G5UE010A01P1
Variation-00 – 103.5 VDC	G5UE010A01P2
Variation-00 – 207 VDC	G5UE010A01P3
Variation 02 – 24 VDC	G5UE010A21P1
Variation 02 – 103.5 VDC	G5UE010A21P2
Variation 02 – 207 VDC	G5UE010A21P3
3 Friction Disc	
Standard Synthetic Disc	A5UE010B1P1
Large Bore Synthetic Disc	A5UE010B3P1
Standard Metallic Disc	A5UE010B9P1
Large Bore Metallic Disc	A5UE010B15P1
4 Options	
Hand Release	A5UE010K1P1
Dust Cover	A5UE010C4P1
5 Friction Flange & Screw Kit	
Intermediate Flange	A5UE010C312P2
Thick Flange	A5UE010C301P1
Short Screw	A5UE010K2P1
Long Screw	A5UE010K2P2
7 Hub Bore size	
Pilot Bore – 10MM	A5UE010C500P1
Hub Bored W/Keyway – 1/2"	A5UE010C500P13
Large Bore Hub W/Keyway – 5/8"	consult factory
Large Bore Hub W/Keyway – 3/4"	consult factory
8 Detection Kit	V4NST7

1 ERD020

Description	Part Number
2 & 6 Variation 00 – 24 VDC	G5UE020A01P1
Variation 00 – 103.5 VDC	G5UE020A01P2
Variation 00 – 207 VDC	G5UE020A01P3
Variation 02 – 24 VDC	G5UE020A21P1
Variation 02 – 103.5 VDC	G5UE020A21P2
Variation 02 – 207 VDC	G5UE020A21P3
3 Friction Disc	
Standard Synthetic Disc	N/A
Large Bore Synthetic Disc	N/A
Standard Metallic Disc	A5UE020B9P1
Large Bore Metallic Disc	A5UE020B3P1
4 Options	
Hand Release	A5UE020K1P1
Dust Cover	A5UE020C4P1
5 Friction Flange & Screw Kit	
Intermediate Flange	A5UE020C308P2
Thick Flange	A5UE020C301P1
Short Screw	A5UE020K2P1
Long Screw	A5UE020K2P2
7 Hub Bore size	
Pilot Bore – 10MM	A5UE020C500P1
Hub Bored W/Keyway – 15MM	A5UE020C500P2
Hub Bored W/Keyway – 20MM	A5UE020C500P3
Hub Bored W/Keyway – 11MM	A5UE020C500P6
Hub Bored W/Keyway – 14MM	A5UE020C500P7
Hub Bored W/Keyway – 1/2"	A5UE020C500P15
Hub Bored W/Keyway – 5/8"	A5UE020C500P16
Hub Bored W/Keyway – 3/4"	A5UE020C500P17
Hub Bored W/Keyway – 7/8"	A5UE020C500P18
Large Bore Hub W/Keyway – 1"	consult factory
8 Detection Kit	V4NST7

1 ERD035

Description	Part Number
2 & 6 Variation-00 – 24 VDC	G5UE035A01P1
Variation-00 – 103.5 VDC	G5UE035A01P2
Variation-00 – 207 VDC	G5UE035A01P3
Variation 02 – 24 VDC	G5UE035A21P1
Variation 02 – 103.5 VDC	G5UE035A21P2
Variation 02 – 207 VDC	G5UE035A21P3
3 Friction Disc	
Standard Synthetic Disc	N/A
Large Bore Synthetic Disc	N/A
Standard Metallic Disc	A5UE035B2P1
Large Bore Metallic Disc	A5UE035B5P1-NM
4 Options	
Hand Release	A5UE035K1P1
Dust Cover	642-0013
5 Friction Flange & Screw Kit	
Intermediate Flange	A5UE035C311P2
Thick Flange	A5UE035C301P1
Short Screw	A5UE035K2P1
Long Screw	A5UE035K2P2
7 Hub Bore size	
Pilot Bore Hub – 14MM	A5UE035C500P1
Hub Bored W/Keyway – 20MM	A5UE035C500P2

ERD Series Electrically Released Brakes

Hub Bored W/Keyway – 25MM	A5UE035C500P3
Hub Bored W/Keyway – 15MM	A5UE035C500P7
Hub Bored W/Keyway – 5/8"	A5UE035C503P1
Hub Bored W/Keyway – 3/4"	A5UE035C503P3
Hub Bored W/Keyway – 7/8"	A5UE035C503P4
Hub Bored W/Keyway – 1"	A5UE035C503P2
Large Bore Hub W/Keyway - 1-1/8"	consult factory

8 Detection Kit	V4NST7	
Rectifiers		
Half Wave	MCS-141-1	ACG830A1P1
Full Wave	MCS-141-2	ACG830A1P2

1 ERD060

Description	Part Number
2 & 6 Variation 00 – 24 VDC	BT212094250
Variation 00 – 103.5 VDC	BT212094251
Variation 00 – 207 VDC	BT212094252
Variation 02 – 24 VDC	BT212094246
Variation 02 – 103.5 VDC	BT212094247
Variation 02 – 207 VDC	BT212094248

3 Friction Disc	
Standard Metallic Friction Disc (M)	BT212094481
Metallic Friction Disc (HT)	BT212094185

4 Options	
Dust Cover	BT312026932
Hand Release	BT212094492

5 Friction Flange & Screw Kit	
Thick Friction Plate	BT312026917
Short Screw (for Thick Friction Plate)	BT212094220
Long Screw (for No Friction Plate)	BT212094221

7 Hub Bore Size	
Pilot Bore Hub – 14MM	BT312026935
Hub Bored W/Keyway – 25MM	BT312026936
Hub Bored W/Keyway – 30MM	BT312026937
Hub Bored W/Keyway – 5/8"	BT312028396
Hub Bored W/Keyway – 1"	BT312028397

8 Detection Kit	BT212095409
------------------------	-------------

1 ERD100

Description	Part Number
2 & 6 Variation 00 – 24 VDC	BT212094258
Variation 00 – 103.5 VDC	BT212094259
Variation 00 – 207 VDC	BT212094260
Variation 02 – 24 VDC	BT212094254
Variation 02 – 103.5 VDC	BT212094255
Variation 02 – 207 VDC	BT212094256

3 Friction Disc	
Standard Metallic Friction Disc (M)	BT212094497
Metallic Friction Disc (HT)	BT212094186

4 Options	
Dust Cover	BT312026934
Hand Release	BT212094508

5 Friction Flange & Screw Kit	
Thick Friction Plate	BT312026928
Short Screw (for Thick Friction Plate)	BT212094223
Long Screw (for No Friction Plate)	BT212094224

7 Hub Bore Size	
Pilot Bore Hub – 15MM	BT312026938
Hub Bored W/Keyway – 25MM	BT312026939
Hub Bored W/Keyway – 30MM	BT312026940

Hub Bored W/Keyway – 35MM	BT312026941
Hub Bored W/Keyway – 5/8"	BT312028398
Hub Bored W/Keyway – 1"	BT312028398
Hub Bored W/Keyway – 1-3/8"	BT312028400

8 Detection Kit	BT212095409
------------------------	-------------

1 ERD170

Description	Part Number
2 & 6 Variation 00 – 24 VDC	BT212094358
Variation 00 – 103.5 VDC	BT212094359
Variation 00 – 207 VDC	BT212094360
Variation 02 – 24 VDC	BT212094355
Variation 02 – 103.5 VDC	BT212094356
Variation 02 – 207 VDC	BT212094357

3 Friction Disc	
Standard Metallic Friction Disc (M)	BT212094448
Metallic Friction Disc (HT)	BT212094329

4 Options	
Dust Cover	BT312027158
Hand Release	BT212094522

5 Friction Flange & Screw Kit	
Thick Friction Plate	BT312027135
Short Screw (for Thick Friction Plate)	BT212094350
Long Screw (for No Friction Plate)	BT212094351

7 Hub Bore Size	
Pilot Bore Hub – 20MM	BT312027150
Hub Bored W/Keyway – 35MM	BT312027151
Hub Bored W/Keyway – 40MM	BT312027152
Hub Bored W/Keyway – 45MM	BT312027153
Hub Bored W/Keyway – 7/8"	BT312028401
Hub Bored W/Keyway – 1-3/8"	BT312028402
Hub Bored W/Keyway – 1-3/4"	BT312028403

8 Detection Kit	BT212095409
------------------------	-------------

1 ERD300

Description	Part Number
2 & 6 Variation 00 – 24 VDC	BT212094364
Variation 00 – 103.5 VDC	BT212094365
Variation 00 – 207 VDC	BT212094366
Variation 02 – 24 VDC	BT212094361
Variation 02 – 103.5 VDC	BT212094362
Variation 02 – 207 VDC	BT212094363

3 Friction Disc	
Standard Metallic Friction Disc (M)	BT212094449
Metallic Friction Disc (HT)	BT212094334

4 Options	
Dust Cover	BT312027159
Hand Release	BT212094536

5 Friction Flange & Screw Kit	
Thick Friction Plate	BT312027146
Short Screw (for Thick Friction Plate)	BT212094353
Long Screw (for No Friction Plate)	BT212094354

7 Hub Bore Size	
Pilot Bore Hub – 25MM	BT312027154
Hub Bored W/Keyway – 35MM	BT312027155
Hub Bored W/Keyway – 40MM	BT312027156
Hub Bored W/Keyway – 45MM	BT312027157
Hub Bored W/Keyway – 1"	BT312028404
Hub Bored W/Keyway – 1-3/8"	BT312028405
Hub Bored W/Keyway – 1-3/4"	BT312028406

8 Detection Kit	BT212095409
------------------------	-------------

Permanent Magnet Electrically Released Brakes

Permanent Magnet Brakes

Frequent cycling applications which regularly engage the brake to stop a moving load call for FB or ER models. Frequent cycling keeps working surfaces burnished and operating at top efficiency. The convenience of power off braking combines with stopping capability in the event of power failure to provide the ideal brake for many applications.

FB Series (Shaft Mounted)



FB Series permanent magnet brakes are offered as off-the-shelf, pre-assembled packages in three sizes. Packaged products are easy to install.

ER Series (Flange Mounted)



ER Series permanent magnet brakes allow customers added flexibility and larger sizes. 825 and 1225 are available in both standard and heavy duty models.

Principle of Operation

Electrically Released Brakes automatically engage when the power goes off. Reliable permanent magnets provide a permanent holding force. Electrical power applied to the coil nullifies the attraction of the permanent magnet and the brake releases. No power is required to stop or hold a load.

Packaged Convenience for Power Off Applications

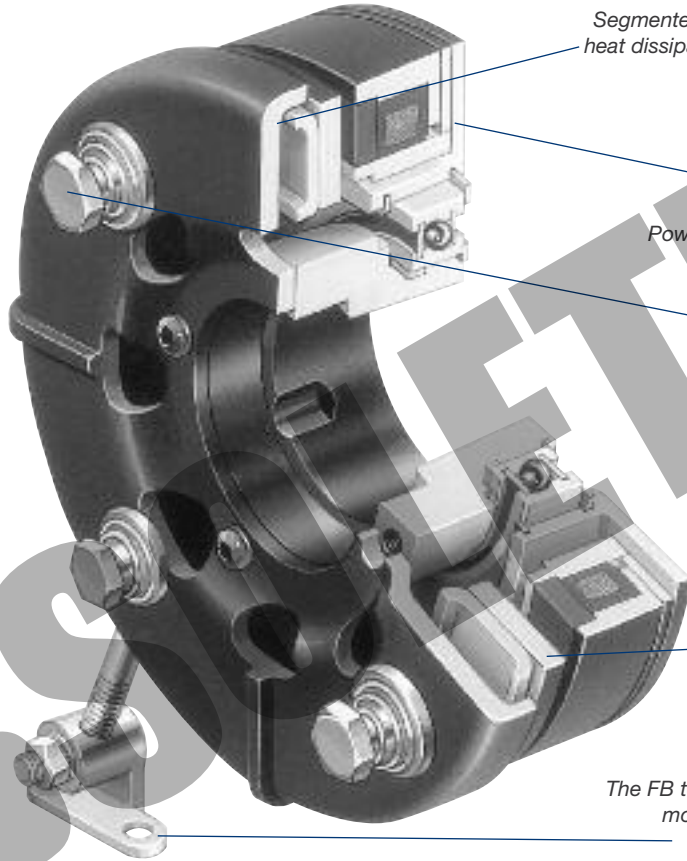

Long Life – High Cycle Rates

Segmented armature provides high heat dissipation and long service life. Capable of rapid cycling.

High Torque

Powerful permanent magnets.

Autogap™

Automatic wear adjust.

Electrically Released

Brake automatically engages when power is turned off– releases when power is applied.

Mounting Flexibility

The FB torque arm feature permits mounting on any shaft. Wide range of shaft sizes.

FB Magnetically Set, Electrically Released, Dynamic Engagement Brake

Packaged brake assembly complete with conduit box is ready to install.

This brake must be engaged while the shaft is in motion. Shaft speed should be 100 RPM or greater when the brake is engaged. This style brake offers quick and easy bearing mounting on the shaft, high cycle rate capability, and excellent life.

FB Brake on double shaft motor.



Features

- Designed for dynamic stopping operations
- Brake automatically engages when power is turned off
- High cycle rate capability
- Never needs adjustment – automatically compensates for wear
- Mounting flexibility
- Powerful permanent magnets
- Segmented armature design provides high heat dissipation and long service life.
- Complete controllability for soft stops.
- UL listed

FB Series Electrically Released Brakes

Selection/Ordering Information

Selection Procedure

FB (Shaft Mounted) Series brakes are available in three models to provide an optimum size to match your application requirements. Static torque capabilities range from 10.5 lb.ft. to 56 lb.ft.

1. Verify that the brake will be cycled frequently in normal operation.
2. Determine the horsepower and speed at the brake location.
3. The correct size Electrically Released Brake is shown at the intersection of the HP and shaft speed on the chart below.
4. Available bore sizes are listed in the bore data chart. When ordering, specify voltage and bore size.
5. Five motor adapters are also available for mounting Electrically Released Brakes on single shaft extension motors (see motor adapter bore size chart on page 136). For double shaft extension motors, the adapter can be eliminated. Specify motor shaft size.

Horsepower vs. Shaft Speed*

HP	SHAFT SPEED AT BRAKE (IN RPM)*																				
	100	200	300	400	500	600	700	800	900	1000	1100	1200	1500	1800	2000	2400	3000	3600	4000	4500	
1/12																					
1/8																					
1/6																					
1/4																					
1/3																					
1/2																					
3/4																					
1																					
1-1/2																					
2																					
3																					
5																					
7-1/2																					
10																					
15																					

* For applications which require stopping below 100 RPM, consult factory.

Specifications

Model	Voltage DC	Static Torque (lb.ft.)	Max. RPM	Total Weight (lbs.)
FB-375	24V 90V	10.5	5000	4.5
FB-475	24V 90V	21	4500	6.3
FB-650	24V 90V	56	3600	13.2

How to Order

1. Specify brake part number.
2. For FB-475 and FB-650, order bushing separately (see page 139). FB-375 does not require a bushing.
3. For single shaft motor mounting, order adapter separately (Item 2 below). Specify the following bore size for the FB brake. This is the bore size required for mounting the electrically released brake on the end of the motor adapter.
 FB-375 5/8" bore
 FB-475 1 bore
 FB-650 1-3/8" bore
4. See the Controls Section for controls. FB Series brakes require a control with a potentiometer to vary brake channel output.

CBC-200, 300 or 500/550 are recommended.

Electrically Released Brake Assemblies

Unit Size	Bore	Voltage DC	Part Number
FB-375	1/2"	24	5390-170-024
FB-375	1/2"	90	5390-170-021
FB-375	5/8"	24	5390-170-023
FB-375	5/8"	90	5390-170-022
FB-475	—	24	5391-170-012
FB-475	—	90	5391-170-009
FB-650	—	24	5392-170-010
FB-650	—	90	5392-170-007

Typical Application

Storage Elevator

These brakes will stop as well as keep a load in position until they are electrically released. They are also used as emergency stopping devices.

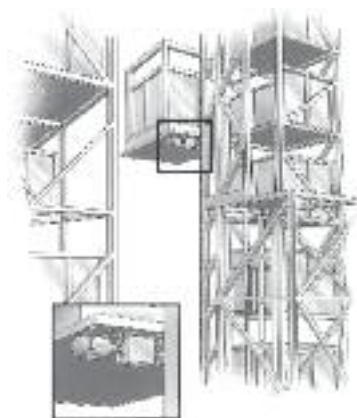

Permanent Magnet Electrically Released Brakes

Motor and Shaft Adapters

Motor Adapter Bore Sizes

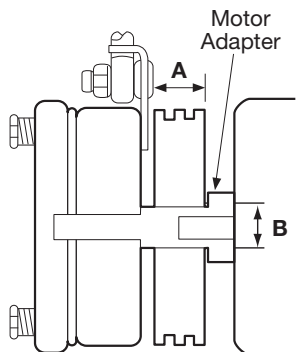

Model Size	Motor Shaft Size	A Usable Length	B Dia.	When using an adapter order the following Dodge Bushing	
				Adapter	
375	.625	2.000	.875	5380-101-005	*None
	.875	2.250	1.250	5380-101-004	*None
475	1.125	2.750	1.625	5381-101-003	#1008 1"
650	1.375	3.000	2.000	5382-101-003	#1310 1.375"
	1.625	3.625	2.250	5382-101-002	#1310 1.375"

*Order FB-375 with 5/8" bore.

FB Shaft Adapter

Shown below are dimensions and specifications for the optional shaft adapter available for mounting FB Series brakes on a motor. A standard sheave, pulley, or sprocket, with either a tapered bushing or straight bore, can be installed on the shaft adapter. The brake is mounted on the end of the shaft adapter and the complete assembly fits onto the motor shaft, secured with setscrews. Fitting the belts or chain and torque arm completes the installation.

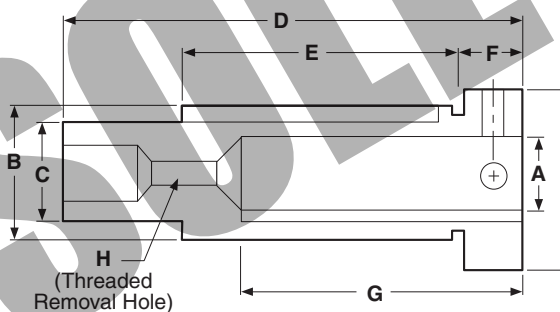

Model	A	Kwy.	B	Kwy.	Key Part No.	C	Kwy.	Key Part No.	Dodge Bushing Size	D	E	F	G	H	I
FB-375	5/8	3/16 x 3/32	7/8	3/16 x 3/32	590-0016	5/8	3/16 x 3/32	590-0043	None	4.391 4.359	2	.391 .359	2	1/4-20 UNC	1.125
FB-375	7/8	3/16 x 3/32	1-1/4	1/4 x 1/8	590-0022	5/8	3/16 x 3/32	590-0043	None	4.578 4.742	2-1/4	.516 .484	2-1/4	1/4-20 UNC	1.500
FB-475	1-1/8	1/4 x 1/8	1-5/8	3/8 x 3/16	590-0041	1	1/4 x 1/8	—	#1008 1"	4.516 4.484	2-3/4	.641 .609	2-3/4	1/2-13 UNC	1.750
FB-650	1-3/8	5/16 x 5/32	2	1/2 x 1/4	590-0042	1-3/8	5/16 x 5/32	590-0044	#1310 1-3/8"	5.547 5.515	3-3/8	.641 .609	3-3/8	1/2-13 UNC	2.125
FB-650	1-5/8	3/8 x 3/16	2-1/4	1/2 x 1/4	590-0042	1-3/8	5/16 x 5/32	590-0044	#1310 1-3/8"	6.172 6.140	4	.641 .609	4	1/2-13 UNC	2.375

All dimensions are nominal unless otherwise noted.

FB Series Electrically Released Brakes

FB-375, FB-475, FB-650

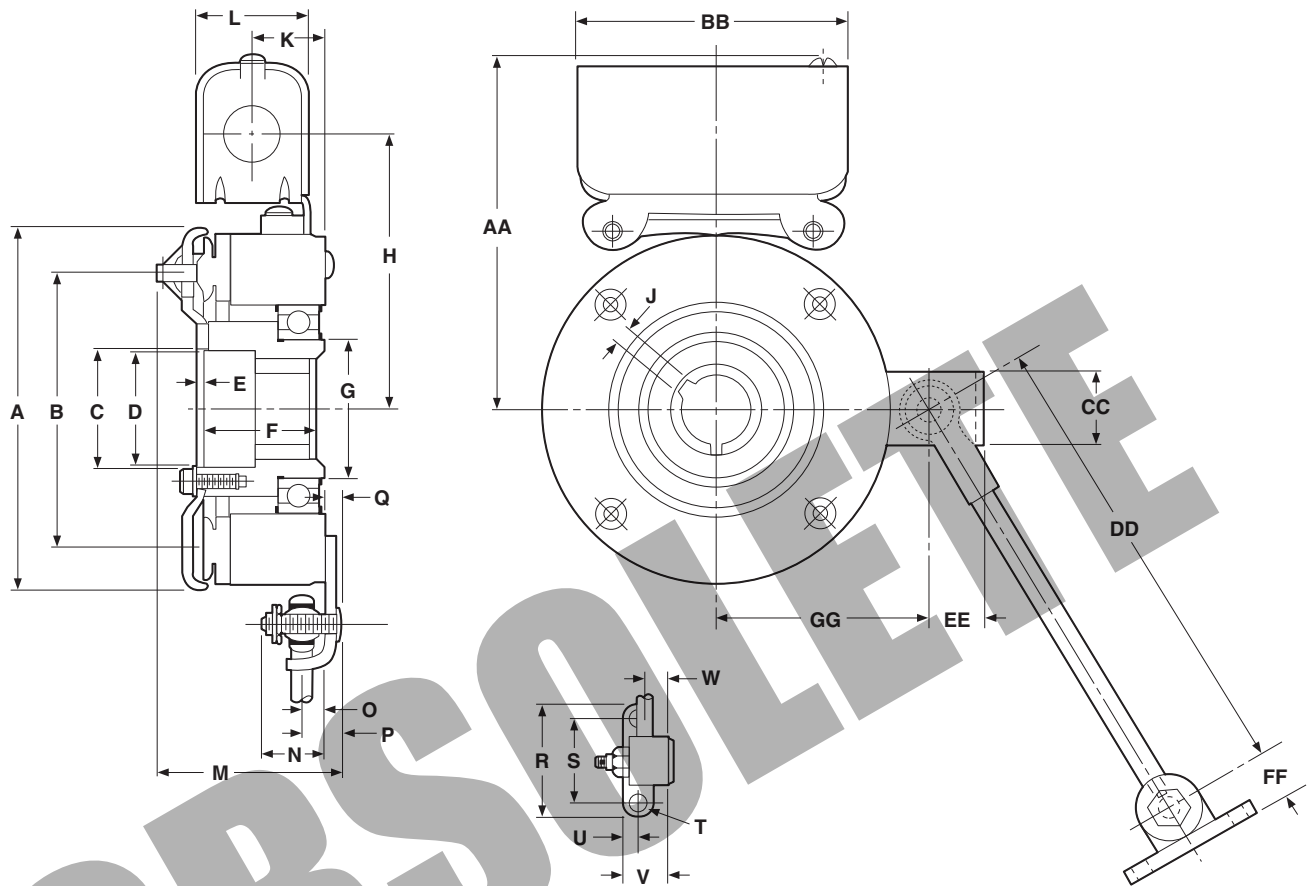

Dimensions

All dimensions are nominal, unless otherwise noted.

Size	A Max.	B Dia.	C Min.	D Dia.	E Min.	F	G Dia.	H	J	K	L	M Max.	N	O	P
375	4.078	3.125	.7505	—	.031	1.906	1.375	3.359	.187	1.281	1.546	2.716	.843	.281	.531
475	5.171	4.000	1.663	1.593	—	1.875	1.781	3.875	—	1.218	1.546	3.390	1.093	.312	.531
650	6.578	5.125	2.343	2.281	—	2.250	2.562	4.800	—	1.550	1.546	3.765	1.031	.343	.640

Size	Q Max.	R	S Dia.	T	U	V	W	AA Max.	BB	CC	DD	EE	FF	GG
375	—	2.000	1.500	.270	.270 .260	.781	.359	4.468	3.750	1.000	8.000	.666	.635	2.578
475	.281	2.000	1.500	.270	.270 .260	.781	.390	4.984	3.750	1.000	10.000	.697	.635	3.094
650	.359	2.000	1.500	.270	.270 .260	.781	.437	5.843	3.750	1.125	11.000	.843	.635	4.062

Bore Data (Key furnished)

Size	Bore Dia.	Keyway
FB-375	.626/.625 .501/.500	3/16 x 3/32 1/8 x 1/16
FB-475	.500 – .562	1/8 x 1/16
Dodge #1008	.625 – .875 .937 – 1.000	3/16 x 3/32 1/4 x 1/8
FB-650	.500 – .562	1/8 x 1/16
Dodge #1310	.625 – .875 .937 – 1.250 1.312 – 1.375	3/16 x 3/32 1/4 x 1/8 5/16 x 5/32

Note: FB-375 has a straight bore. Bushing not required.
Bushings also available in metric bores. See page 139.

ER Series Electrically Released Brakes

Ideal for Dynamic Braking Applications

ER Series Dynamic Engagement Brakes

This brake must be engaged while the shaft is in motion. Shaft speed should be 100 RPM or greater when the brake is engaged. This style brake offers a bulkhead flange mounting system, the highest torque rating offered by Warner Electric in the power released series, high cycle rate capability, and excellent life.

- Expands the electrically released product family with two larger sizes
- Designed for dynamic stopping operations
- High cycle rate capability
- Inside or outside mount options for 475 or 650 sizes
- Normal or heavy duty options available in larger sizes

Flange Mounted Brakes

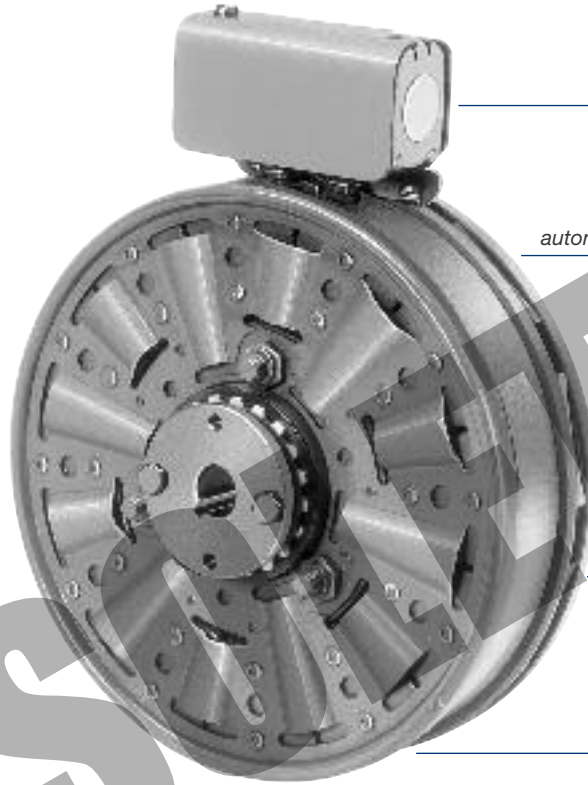

Powerful permanent magnets.

Never needs adjustment—automatically compensates for wear.

Brake automatically engages when power is turned off.

Pre-burnished to assure rated torque upon installation.

Segmented armature design provides high heat dissipation and long service life.

Selection Procedure

ER Series brakes are available in five sizes. Static torque ratings range from 10.5 lb.ft. to 400 lb.ft.

1. Verify that the brake will be cycled frequently in normal operation.
2. Determine the horsepower and speed at the brake location.
3. The correct size ER Series brake is shown at the intersection of the HP and shaft speed.
4. When ordering, specify voltage and bore size. Available bore sizes are listed in the specifications chart.

Horsepower vs. Shaft Speed

HP	SHAFT SPEED AT BRAKE (IN RPM)																			
	100	200	300	400	500	600	700	800	900	1000	1100	1200	1500	1800	2000	2400	3000	3600	4000	4500
1/12																				
1/8																				
1/6																				
1/4																				
1/3																				
1/2																				
3/4																				
1																				
1-1/2																				
2																				
3																				
5																				
7-1/2																				
10																				
15																				
20																				
25																				
30																				
40																				
50																				
60																				
75																				

How to Order

1. Specify model number
2. For thru-shaft mounting, specify bore size. For ER-475 and ER-650 order bushing separately, ER-375 does not require a bushing.
3. Models ER-475 and ER-650: Specify inside or outside mount. Models ER-825 and ER-1225: Specify normal or heavy duty.
4. See the Controls Section for controls. ER Series brakes require a control with a potentiometer to vary brake channel output. Recommended are:
For ER-825 use CBC-200, -500, or -550.
For ER-1225, use MCS-805-1 or -2.

ER Series Electrically Released Brakes

Specifications

Model	Bore Size	Voltage DC	Static Torque lb. ft.	Max. RPM	Drive	Inertia lb.ft. ²		Weight lbs.		Total Weight lbs.
						Arm. & Carrier	Hub	Arm. & Carrier	Hub	
ER-375	.500" & .625"	90V	10.5	5000	-	.010	.001	.60	.49	4.5
ER-475	.500" to 1.000" Dodge #1008	90V	21	4500	-	.072	.006	1.13		6.3
ER-650	.500" to 1.375" Dodge #1310	90V	56	3600	-	.106	.020	2.3	1.6	13.2
ER-825 ND	.500" to 1.625" Dodge #1615	90V	125	3600	Pin Spline	.323 .326	.043 .006	4.783 5.263	1.857 .834	15.6
ER-825 HD	.500" to 1.500" Browning #H-1	90V	125	3600	Pin Spline	.323 .326	.043 .006	4.783 5.263	1.857 .834	15.6
ER-1225 ND	.937" to 3.00" Dodge #3030	35-75V	400	3000	Pin Spline	1.667 1.737	.380 .077	10.227 13.317	6.716 3.582	60.3
ER-1225 HD	.75" to 2.687" Browning #Q-1	35-75V	400	3000	Pin Spline	1.667 1.737	.380 .077	10.227 13.317	6.716 3.582	60.3

Bushing Part Numbers

Shaft Size	Keyway Size	Bushing Number		Shaft Size	Keyway Size	Bushing Number		Shaft Size	Keyway Size	Bushing Number	
		Warner Electric	Browning			Warner Electric	Browning			Warner Electric	Browning
1/2	1/8 x 1/16	180-0002		2-5/16	5/8 x 5/16	180-0051		1-15/16	1/2 x 1/4	180-0278	
9/16	1/8 x 1/16	180-0003		2-3/8	5/8 x 5/16	180-0052		2	1/2 x 1/4	180-0279	
5/8	3/16 x 3/32	180-0004		2-7/16	5/8 x 5/16	180-0053		2-1/16	1/2 x 1/4	180-0280	
11/16	3/16 x 3/32	180-0005		2-1/2	5/8 x 5/16	180-0054	QI-2	2-1/8	1/2 x 1/4	180-0281	
3/4	3/16 x 3/32	180-0006		2-9/16	5/8 x 5/16	180-0055		2-3/16	1/2 x 1/4	180-0282	
13/16	3/16 x 3/32	180-0007		2-5/8	5/8 x 5/16	180-0056		2-1/4	1/2 x 1/4	180-0283	
7/8	3/16 x 3/32	180-0008		2-11/16	5/8 x 5/16	180-0057		2-5/16	5/8 x 5/16	180-0284	
15/16	1/4 x 1/8	180-0009	H-1	1/2	1/8 x 1/16	180-0131		2-3/8	5/8 x 5/16	180-0285	
1	1/4 x 1/8	180-0010		9/16	1/8 x 1/16	180-0132		2-7/16	5/8 x 5/16	180-0286	3030
1-1/16	1/4 x 1/8	180-0011		5/8	3/16 x 3/32	180-0133		2-1/2	5/8 x 5/16	180-0287	
1-1/8	1/4 x 1/8	180-0012		11/16	3/16 x 3/32	180-0134		2-9/16	5/8 x 5/16	180-0288	
1-3/16	1/4 x 1/8	180-0013		3/4	3/16 x 3/32	180-0135		2-5/8	5/8 x 5/16	180-0289	
1-1/4	1/4 x 1/8	180-0014		13/16	3/16 x 3/32	180-0136		2-11/16	5/8 x 5/16	180-0290	
1-5/16	5/16 x 5/32	180-0015		7/8	3/16 x 3/32	180-0137		2-3/4	5/8 x 5/16	180-0291	
1-3/8	5/16 x 5/32	180-0016		15/16	1/4 x 1/8	180-0138		2-13/16	3/4 x 3/8	180-0292	
1-7/16	3/8 x 3/16	180-0017	H-2	1	1/4 x 1/8	180-0139		2-7/8	3/4 x 3/8	180-0293	
1-1/2	3/8 x 3/16	180-0018		1-1/16	1/4 x 1/8	180-0140	1615	2-15/16	3/4 x 3/8	180-0294	
3/4	3/16 x 3/32	180-0026		1-1/8	1/4 x 1/8	180-0141		3	3/4 x 3/8	180-0295	
13/16	3/16 x 3/32	180-0027		1-3/16	1/4 x 1/8	180-0142		1/2	1/8 x 1/16	180-0410	
7/8	3/16 x 3/32	180-0028		1-1/4	1/4 x 1/8	180-0143		9/16	1/8 x 1/16	180-0411	
15/16	1/4 x 1/8	180-0029		1-5/16	5/16 x 5/32	180-0144		5/8	3/16 x 3/32	180-0412	
1	1/4 x 1/8	180-0030		1-3/8	5/16 x 5/32	180-0145		11/16	3/16 x 3/32	180-0413	
1-1/16	1/4 x 1/8	180-0031		1-7/16	3/8 x 3/16	180-0146		3/4	3/16 x 3/32	180-0414	1008
1-1/8	1/4 x 1/8	180-0032		1-1/2	3/8 x 3/16	180-0147		13/16	3/16 x 3/32	180-0415	
1-3/16	1/4 x 1/8	180-0033		1-9/16	3/8 x 3/16	180-0148		7/8	3/16 x 3/32	180-0416	
1-1/4	1/4 x 1/8	180-0034		1-5/8	3/8 x 3/16	180-0149		15/16	1/4 x 1/16	180-0417	
1-5/16	5/16 x 5/32	180-0035	QI-1	15/16	1/4 x 1/8	180-0262		1	1/4 x 1/16	180-0418	
1-3/8	5/16 x 5/32	180-0036		1	1/4 x 1/8	180-0263		1/2	1/8 x 1/16	180-0421	
1-7/16	3/8 x 3/16	180-0037		1-1/16	1/4 x 1/8	180-0264		9/16	1/8 x 1/16	180-0422	
1-1/2	3/8 x 3/16	180-0038		1-1/8	1/4 x 1/8	180-0265		5/8	3/16 x 3/32	180-0423	
1-9/16	3/8 x 3/16	180-0039		1-3/16	1/4 x 1/8	180-0266		11/16	3/16 x 3/32	180-0424	
1-5/8	3/8 x 3/16	180-0040		1-1/4	1/4 x 1/8	180-0267		3/4	3/16 x 3/32	180-0425	
1-11/16	3/8 x 3/16	180-0041		1-5/16	5/16 x 5/32	180-0268		13/16	3/16 x 3/32	180-0426	
1-3/4	3/8 x 3/16	180-0042		1-3/8	5/16 x 5/32	180-0269	3030	7/8	3/16 x 3/32	180-0427	
1-13/16	1/2 x 1/4	180-0043		1-7/16	3/8 x 3/16	180-0270		15/16	1/4 x 1/16	180-0428	1310
1-7/8	1/2 x 1/4	180-0044		1-1/2	3/8 x 3/16	180-0271		1	1/4 x 1/8	180-0429	
1-15/16	1/2 x 1/4	180-0045		1-9/16	3/8 x 3/16	180-0272		1-1/16	1/4 x 1/8	180-0430	
2	1/2 x 1/4	180-0046		1-5/8	3/8 x 3/16	180-0273		1-1/8	1/4 x 1/8	180-0431	
2-1/16	1/2 x 1/4	180-0047		1-11/16	3/8 x 3/16	180-0274		1-3/16	1/4 x 1/8	180-0432	
2-1/8	1/2 x 1/4	180-0048	QI-2	1-3/4	3/8 x 3/16	180-0275		1-1/4	1/4 x 1/8	180-0433	
2-3/16	1/2 x 1/4	180-0049		1-13/16	1/2 x 1/4	180-0276		1-5/16	15/16 x 5/32	180-0434	
2-1/4	1/2 x 1/4	180-0050		1-7/8	1/2 x 1/4	180-0277		1-3/8	15/16 x 5/32	180-0435	

Browning® is registered to Emerson Electric Co.
Dodge and Browning bushings are also available in metric bores.

ER Series Electrically Released Brakes

ER-375, ER-475, ER-650

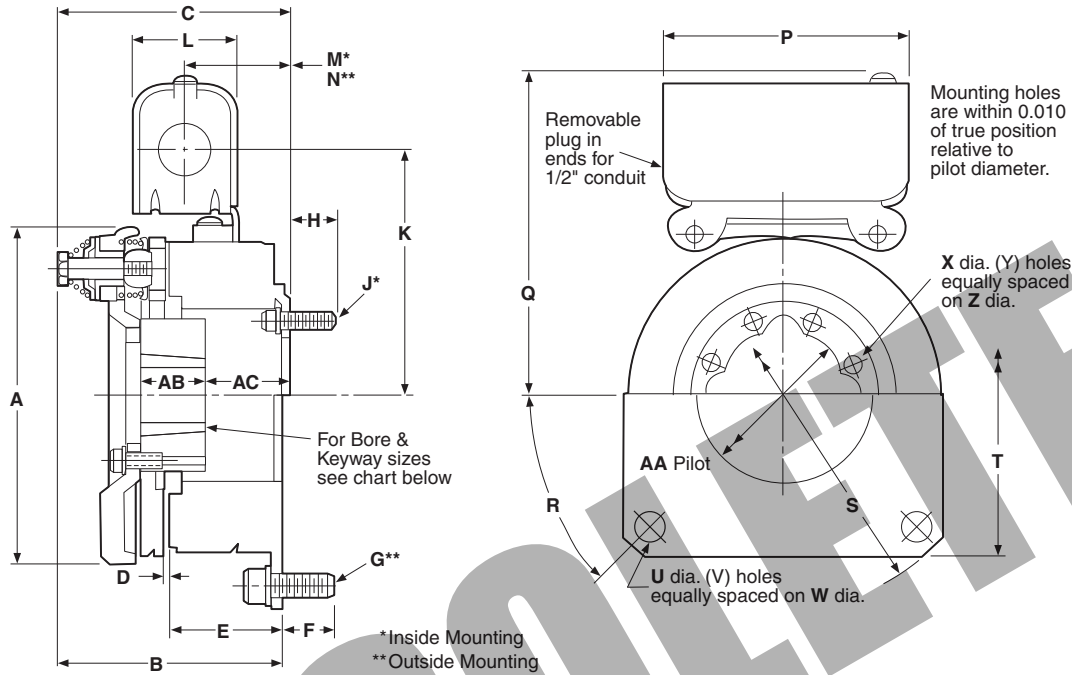

Dimensions

All dimensions are nominal, unless otherwise noted.

Size	A Max.	B Max.	C Max.	D	E	F Max.	G	H Max.	J	K	L	M	N	P
375	4.078	2.583	2.583	.032	1.410	.600	5/16-18 UNC-3A	—	—	3.325	1.547	—	—	3.750
475	5.172	3.195	3.274	.031	1.630	.431	3/8-16 UNC-3A	.390	8-32	3.875	1.547	1.354	1.236	3.750
650	6.578	3.525	3.525	.032	1.880	.542	5/16-18 UNC-3A	.542	5/16-18 UNC-3A	4.800	1.547	—	—	3.750

Size	Q Max.	R	S	T Sq.	U	V	W Dia.	X	Y	Z Dia.	AA Dia.	AB	AC
375	4.505	—	<u>5.625</u> 5.623	—	<u>.350</u> .341	3	5.000	—	—	—	—	23/32	1-3/4
475	5.000	45°	<u>6.500</u> 6.498	5.000	<u>.419</u> .403	4	5.875	<u>.208</u> .201	8	2.375	<u>2.065</u> 2.062	29/32	1-3/16 I.M. 1-1/16 O.M.
650	5.844	45°	<u>8.000</u> 7.998	6.500	<u>.358</u> .338	4	7.250	<u>.358</u> .338	4	3.688	<u>2.822</u> 2.820	1-1/32	1-3/8

Mounting Requirements

Customer Shall Maintain:

- Squareness of brake mounting face with armature hub shaft within .006 T.I.R.
- Concentricity of brake mounting pilot diameter with armature hub shaft within .010 T.I.R.

- If magnet mounting surface is a magnetic material, the magnet is to be insulated approximately 1/2" from that surface with a plate or spacers of non-magnetic material.

ER-375 available outside mounted only.

Bore and Keyway Dimensions

Size	Bore Dia.	Keyway
375	.501/.500	1/8 x 1/16
	.626/.625	3/16 x 3/32
475	.500 - .562	1/8 x 1/16
	.625 - .875	3/16 x 3/32
	.937 - 1.000	1/4 x 1/8
650	.500 - .562	1/8 x 1/16
	.625 - .875	3/16 x 3/32
	1.000 - 1.250 1.312 - 1.375	1/4 x 1/8 5/16 x 5/32

ER Series Electrically Released Brakes

ER-825, ER-1225

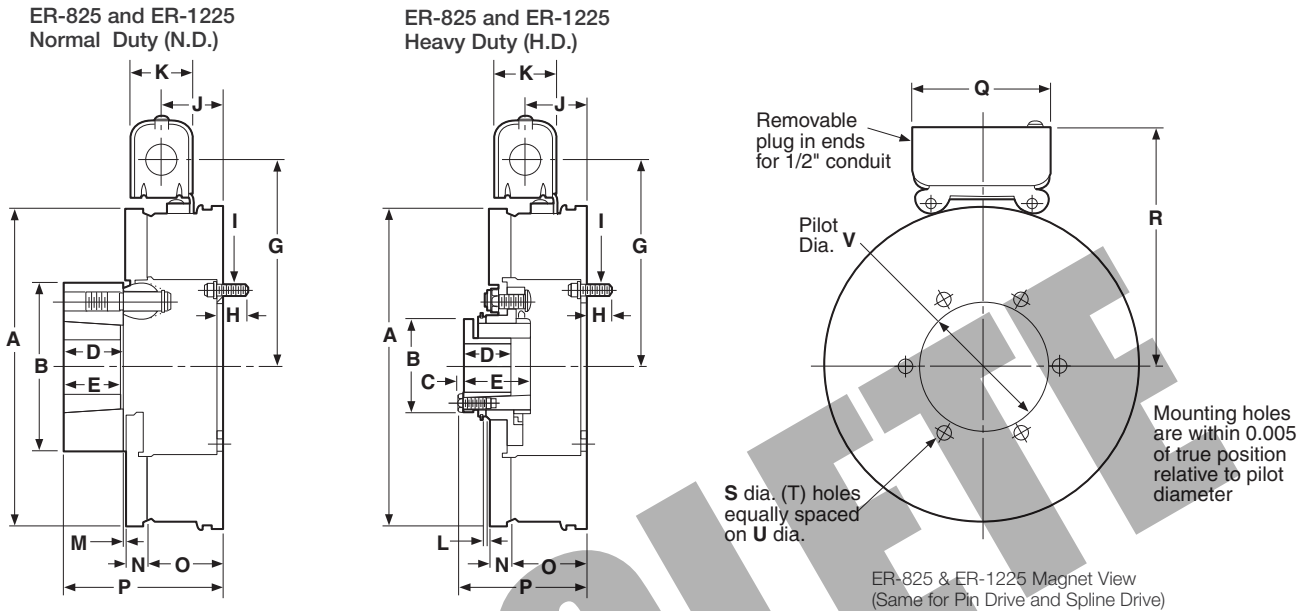

Size	A Max.	B Dia.	C	D	E	G	H Max.	I	J	K Min.	L Min.
825 N.D.	8.656	4.625	—	1.593	1.500	5.625	.531	5/16-18 UNC-3A	1.687	1.546	—
825 H.D.	8.656	2.500	.156	1.250	1.765	5.625	.531	5/16-18 UNC-3A	1.687	1.546	.062
1225 N.D.	12.671	6.875	—	3.000	3.000	7.671	.546	5/16-18 UNC-3A	1.718	1.546	—
1225 H.D.	12.671	4.093	.234	2.500	2.171	7.671	.546	5/16-18 UNC-3A	1.718	1.546	.062

Size	M When New	N	O	P Max.	Q	R Max.	S	T	U	V
825 N.D.	.093	.562	2.080 .338	4.359	3.750	6.750 3.501	.358	6	4.250	3.503
825 H.D.	—	.531	2.080 .338	3.546	3.750	6.750 3.501	.358	6	4.250	3.503
1225 N.D.	.156	.593	2.500 .338	6.218	3.750	8.796 6.376	.358	6	7.250	6.378
1225 H.D.	—	.562	2.500 .338	5.031	3.750	8.796 6.376	.358	6	7.250	6.378

Bore and Keyway Dimensions

ER-825	Bore Dia.	Keyway
Pin Drive	.500 - .562	1/8 x 1/16
	.625 - .875	3/16 x 3/32
	.937 - 1.250	1/4 x 1/8
	1.312 - 1.375	5/16 x 5/32
	1.437 - 1.500	3/8 x 3/16
	1.562 - 1.625*	3/8 x 3/16
Spline Drive	.500 - .562	1/8 x 1/16
	.375 - .625	3/16 x 3/32
	.937 - 1.187	1/4 x 1/8
	1.250*	1/4 x 1/8
	1.312 - 1.375*	5/16 x 5/32
	1.437 - 1.500*	3/8 x 3/16
ER-1225		
Pin Drive	.937 - 1.250	1/4 x 1/8
	1.312 - 1.375	5/16 x 5/32
	1.437 - 1.750	3/8 x 3/16
	1.812 - 2.250	1/2 x 1/4
	2.312 - 2.750	5/8 x 5/16
	2.187 - 3.000*	3/4 x 3/8
Spline Drive	.750 - .875	3/16 x 3/32
	.937 - 1.250	1/4 x 1/8
	1.312 - 1.375	5/16 x 5/32
	1.437 - 1.750	3/8 x 3/16
	1.812 - 2.062	1/2 x 1/4
	2.125 - 2.250*	1/2 x 1/4
	2.312 - 2.687	5/8 x 5/16

*Key furnished

Mounting Requirements

Customer Shall Maintain

1. Squareness of magnet mounting face with armature shaft within .006 T.I.R.
2. Concentricity of magnet mounting pilot diameter with armature shaft within .010 T.I.R.
3. If magnet mounting surface is a magnetic material, the magnet is to be insulated approximately 1/2" from that surface with a plate or spacers of non-magnetic material.

Electrically Released Brakes

For Dynamic Stopping and Cycling Applications

Warner Electric's modular design brakes and clutch/brake units offer material handling system users a high performance alternative to spring-set brakes. These modular units provide long life, maintenance free operation, and consistent performance with minimal downtime.

These brakes are offered in power-off types for double shaft motors and for installation between C-face motor and reducer or other drive device. Powerful permanent magnets generate braking torque. The brakes release when voltage is applied to the coil, countering the force of the permanent magnets. No power is required to stop or hold a load. An optional integral conduit box provides simple wiring direct from the motor power leads.

- Designed for dynamic stopping operations
- Brake automatically engages when power is turned off
- High cycle rate capability
- Never needs adjustment – automatically compensates for wear
- Powerful permanent magnets provide braking force
- Choice of open or enclosed brakes
- Prepackaged, preburnished UM version



Electrically Released Brakes

UM Series (UniModule Clutch/Brakes)

Pre-assembled clutch/electrically released brake modules



- The UM-1020-FBC brake/motor clutch combination is used for clutch/power-off brake applications. It mounts directly to C-face compatible components.
- The UM-2030-FBC brake/input clutch combination is used for clutch/power-off brake applications. It has shafts on both the input and output sides for base mounting.

EUM Series (Enclosed Motor Brakes)

Totally enclosed non-vented units that keep wear particles in and contaminants out



- The EUM-FBB brake unit can be mounted between two C-face compatible components.
- The EUM-MBFB motor brake is mounted directly to the rear of a double-shafted motor.

EM Series (Electro Module Brakes and Clutch/Brakes)

Comprised of individual units that may bolt together to form various combinations



- The EM-FBB brake module mounts between a C-face motor and a gear box or reducer.
- The EM-MBFB motor brake module is mounted to the rear of a double-shafted motor.
- The EM-FBC brake module is used in combination with a motor clutch or input clutch unit to make a clutch/electrically released brake or can be used alone as a brake only.

EEM Series (Enclosed Electro Module Brakes and Clutch/Brakes)

Enclosed electro modules package the hardworking components from EM products into totally enclosed housings



Brake Modules (FBB)

For mounting between a C-face motor and a gearbox or reducer



EM Series (shaft mounted, vented housing)

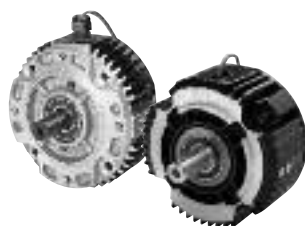

EUM Series (shaft mounted, totally enclosed non-vented housing)

Use for brake alone applications.

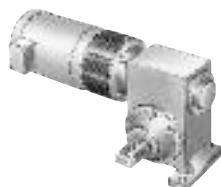
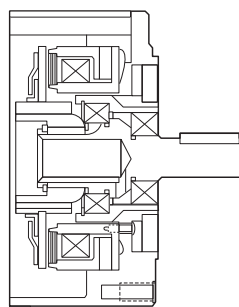

Features

- Single armature for brake alone applications
- Output shaft
- Permanent magnets
- UL listed

EM-FBB

Available in 5 sizes

EUM-FBB

Available in 5 sizes

EM-FBB Electro Module brake unit between a motor and a reducer.

UM-FBC Series Electrically Released Brakes

UniModule Clutch/Electrically Released Brake Combination

Warner Electric offers the convenience of pre-assembled UniModule clutch/electrically released brake packages. Assembly, alignment, and pre-burnishing have been done at the factory. Bolt it on, wire it up, and your clutch/electrically released brake is ready to go. Available in both C-face and base mounted versions.

Warner Electric's unique design employs powerful permanent magnets for maximum torque when power is removed from the brake coil. A small amount of electrical power applied to the brake coil nullifies the permanent magnets and the brake releases. No springs to limit cycle rates. Never any adjustments. No lubrication. These brakes are recommended for dynamic cycling operations only.



Original Design
Sizes 210 & 215

GEN 2 Design
Sizes 50, 100 & 180



1020-FBC

Motor Clutch/Electrically Released Brake

Use for clutch/power-off brake applications. Has clutch input and brake on output side. Employs powerful permanent magnets for maximum torque when power is removed from the brake coil. Basic components are field, rotor, 2 armatures and power-off magnet. See page 149 for specifications.



2030-FBC

Input Clutch/Electrically Released Brake

Use for clutch/power-off brake applications. Has shafts on input and output sides. When electrical power is applied to the brake coil the brake releases. Ideal for dynamic cycling operations. Basic components are field, rotor, 2 armatures and power-off magnet. See page 150 for specifications.



2030-FBC-B

Input Clutch/Electrically Released Brake with Accessory Base Mounting

See page 150 for specifications.

UM-FBC Series Electrically Released Brakes

Selection

UniModule clutch/electrically released brake units may be mounted directly to NEMA C-face motors and reducers, or can be base mounted.

1. Select Configuration

a. NEMA C-face Mounting (1020 Configuration)

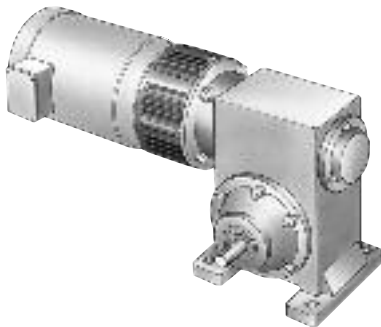

Verify the unit will be cycled frequently.

To select the correct UniModule package, determine the NEMA frame size of your motor and/or reducer, and choose the corresponding size UniModule from the Frame Size Selection chart. Verify torque ratings.

b. Base Mounting (2030 Configuration)

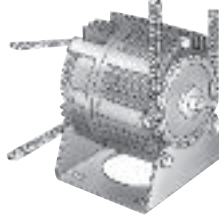

Verify the unit will be cycled frequently.

Select the correct size module from the Horsepower vs. Shaft Speed chart by determining the motor horsepower and RPM at the module location. The correct size UniModule is shown at the intersection of the HP and operating speed. For additional sizing information, refer to the technical sizing procedure (step 2).

2. Determine Technical Requirements

Technical considerations for sizing and selection are torque and heat dissipation. Each merits careful consideration, especially heat dissipation as over time, use in excessive temperature environments will have an adverse effect on bearing life and coil wire insulation integrity.

Compare the calculated torque requirement with the average dynamic torque ratings. Select a unit with adequate torque. If the unit selected on torque is different than the unit selected based on heat, select the larger size unit.

Horsepower vs. Shaft Speed

HP	SHAFT SPEED AT CLUTCH (IN RPM)																		
	100	200	300	400	500	600	700	800	900	1000	1100	1200	1500	1800	2000	2400	3000	3600	
1/4																			
1/2																			
3/4																			
1																			
1-1/2																			
2																			
3																			
5																			
7-1/2																			

Frame Size Selection and Technical Ratings Chart (Blue shaded areas indicate GEN 2 design)

NEMA Frame Size	UniModule Size	Static Torque Brake lb.ft.	Static Torque Clutch lb.ft.	Max. RPM	Voltage DC
56C/48Y	UM-50*	10.5	16	3600	24 or 90
	UM-100**	21	30		
182C/143TC 184C/145TC	UM-180	21	30	3600	24 or 90
213C/182TC 215C/184TC	UM-210	56	95	3600	24 or 90
213TC/215TC	UM-215	56	95	3600	24 or 90

*For 56C/48Y C-frame motors 3/4 HP and smaller, the UM-100 size may be used where extended life is desirable.

**The UM-100 size is recommended for motors 1 HP and larger.

UM-FBC Series Electrically Released Brakes

a. Heat Dissipation Sizing

Friction surfaces slip during the initial period of engagement and, as a result, heat is generated. The clutch/brake selected must have a heat dissipation rating greater than the heat generated by the application. Therefore, in high inertia or high cycle rate applications, it is necessary to check the heat dissipation carefully. Inertia, speed and cycle rate are the required parameters.

Heat dissipation requirement is calculated as follows:

$$E = 1.7 \times WR^2 \times (N/100)^2 \times F$$

where:

E = Heat (lb. ft./min.)

WR^2 = Total reflected inertia at the clutch/brake shaft. Include the clutch/brake output inertia. (lb.ft.²)

N = Speed in revolutions per minute (RPM)

F = Cycle rate in cycles per minute (CPM)

Compare the calculated heat generated in the application to the unit ratings using the heat dissipation curves. Select the appropriate unit that has adequate heat dissipation ability.

Heat Dissipation Curves

Size 50

Maximum Speed 3600 RPM

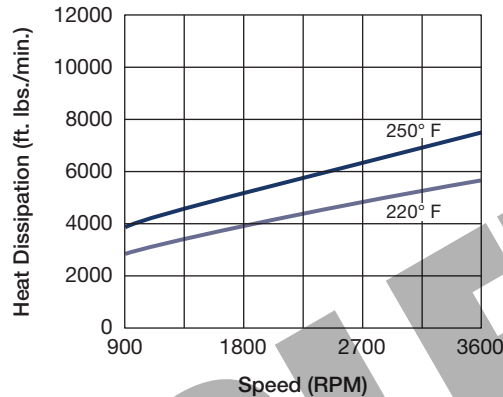

Size 100/180

Maximum Speed 3600 RPM

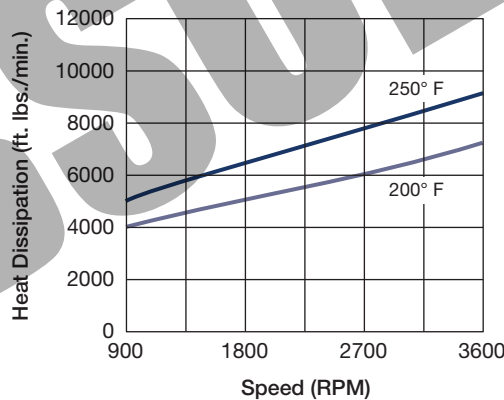

Size 210/215

Maximum Speed 3600 RPM

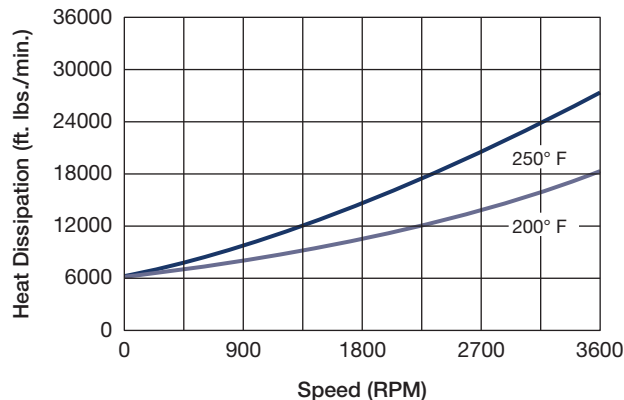

b. Torque Sizing

For most applications, the correct size clutch/brake can be selected from the Horsepower vs. Shaft Speed chart on page 145. Determine the motor horsepower and the RPM at the clutch/brake. The correct size unit is shown at the intersection of horsepower and shaft speed.

If the static torque requirements are known, refer to the technical ratings chart to select a unit.

For some applications, the torque requirement is determined by the time allowed to accelerate and decelerate the load. (This time is generally specified in milliseconds.) For these applications, it is necessary to determine the torque requirement based on load inertia and the time allowed for engagement.

The torque requirements are calculated as follows:

$$T = (WR^2 \times N) / (308 \times t)$$

where:

T = Average Dynamic Torque (lb. ft.)

WR^2 = Total reflected inertia at the clutch/brake shaft. Include the clutch/brake output inertia. (lb. ft.²)

N = Speed in revolutions per minute (RPM)

t = Time allowed for the engagement (sec)

C-face Electrically Released Brake Dynamic Torque Curves

Size 50

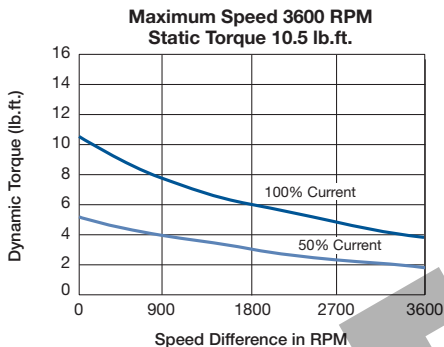

C-face Clutch Dynamic Torque Curves

Size 50

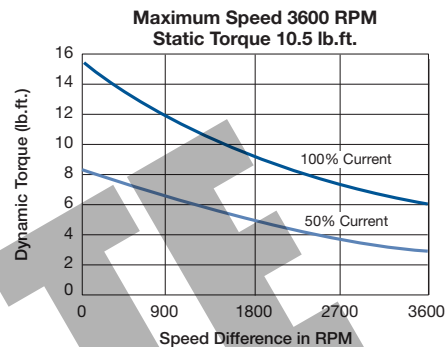

Size 100/180

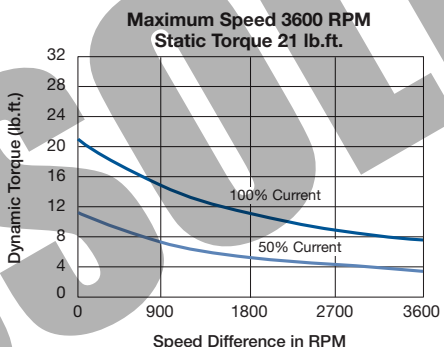

Size 100/180

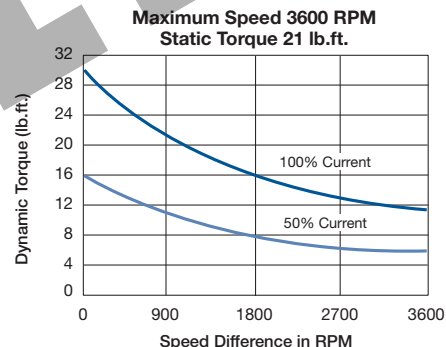

Size 210/215

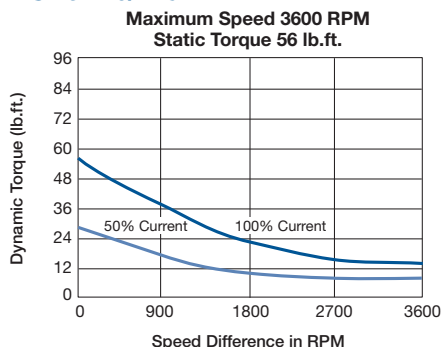

Size 210/215

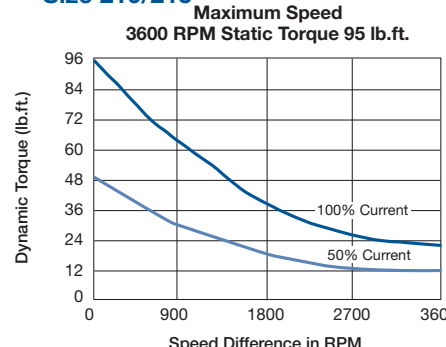

UM-FBC Series Electrically Released Brakes

Ordering Information

Specifications (Max. Speed 3600 RPM) (Blue shaded areas indicate GEN 2 design)

Size	Voltage DC	Weight (lbs.)		Armature		Component Inertia-WR ² (lb. ft. ²)					NEMA Frame Size
		1020		2030		1020		2030			
		1020	2030	(both)	Hub	Shaft	Rotor w/Fan and Hub	Output Shaft	Input Shaft	Rotor w/Fan and Hub	
50	24 90	15.6	18.4	.018	.001	.001	.020	.001	.001	.020	56C/48Y
100	24 90	18.7	21.7	.046	.002	.002	.046	.002	.002	.046	56C/48Y
180	24 90	18.7	21.7	.046	.002	.002	.046	.002	.002	.046	182C/143TC 184C/145TC
210	24 90	36	47	.162	.016	.014	.190	.016	.015	.183	213C/182TC 215C/184TC
215	24 90	37	48	.162	.016	.016	.190	.017	.016	.183	213TC/215TC

3. Select Options

Warner Electric Enclosed UniModules can be fitted with several accessories to extend their capacity and ease of mounting.

4. Select Control

All electrically released modules require a control with a potentiometer that will vary brake channel output. UM-FBC units require either a CBC-300 or a CBC 500/550 control.

Part Numbers (Blue shaded areas indicate GEN 2 design)

Model No.	Voltage DC	GEN 2 Part No.	Original Part No.
Motor Clutch/ ER Brake			
UM-50-1020FBC	24	5370-273-243	5370-273-037
UM-50-1020FBC	90	5370-273-244	5370-273-036
UM-100-1020FBC	24	5370-273-248	5370-273-153
UM-100-1020FBC	90	5370-273-249	5370-273-125
UM-180-1020FBC	24	5370-273-253	5370-273-047
UM-180-1020FBC	90	5370-273-254	5370-273-046
UM-210-1020FBC	24		5371-273-013
UM-210-1020FBC	90		5371-273-012
UM-215-1020FBC	24		5371-273-099
UM-215-1020FBC	90		5371-273-079
Input Clutch/ ER Brake			
UM-50-2030FBC	24	5370-273-258	5370-273-042
UM-50-2030FBC	90	5370-273-259	5370-273-041
UM-100-2030FBC	24	5370-273-263	5370-273-154
UM-100-2030FBC	90	5370-273-264	5370-273-155
UM-180-2030FBC	24	5370-273-268	5370-273-052
UM-180-2030FBC	90	5370-273-269	5370-273-051
UM-210-2030FBC	24		5371-273-018
UM-210-2030FBC	90		5371-273-017
UM-215-2030FBC	24		5371-273-100
UM-215-2030FBC	90		5371-273-101

Accessories

Description	UM Size	Part No.
Conduit Box	UM series All sizes	5370-101-042
Base Mount Kit for 2030 FBC	50/100	5370-101-004
	180	5370-101-002
	210/215	5371-101-019
Motor Mount Kit for 1020 FBC	50/100	5370-101-078
	180	5370-101-079
	210/215	5371-101-012
Cover Kit	50/100/180	5370-101-076

How to Order

1. Specify model number and voltage or the corresponding part number.
2. Specify conduit box, if desired.
3. Specify required control unit. See the Controls Section (page 201).

Ordering Example

UM-50-1020FBC, 90V or 5370-273-244; 5370-101-042 conduit box; CBC-300 control.

UM-FBC Series Electrically Released Brakes

UM-1020 FBC Motor Clutch/Electrically Released Brake

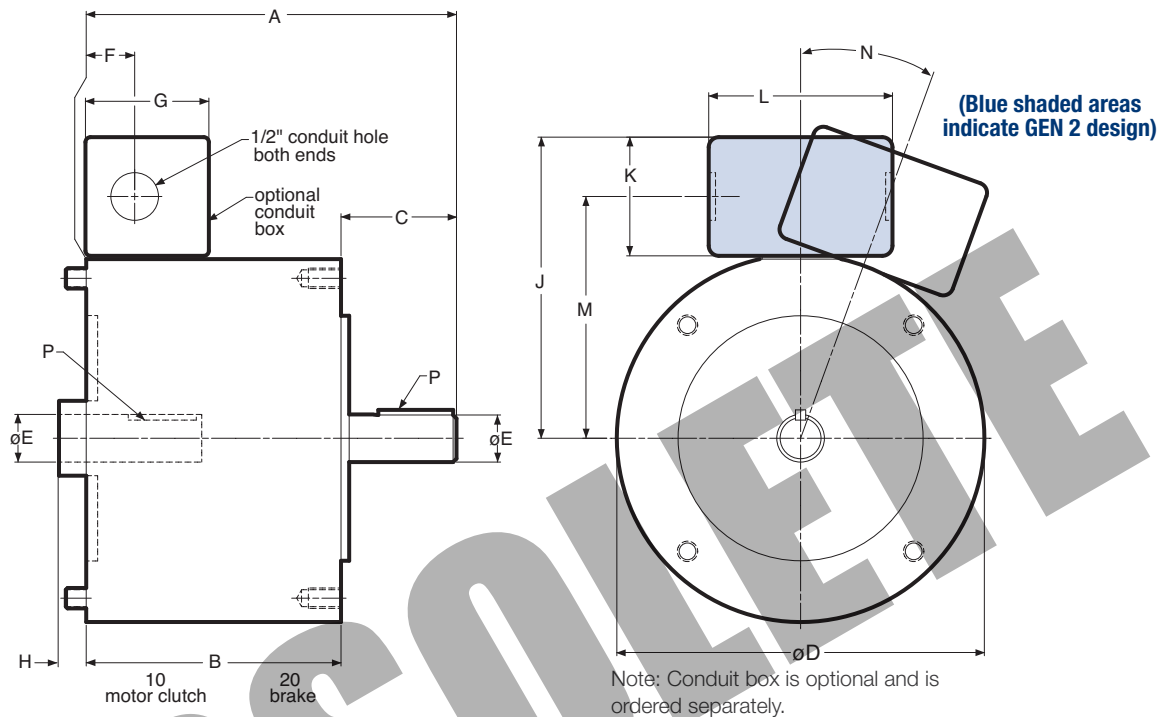

Dimensions (Blue shaded areas indicate GEN 2 design)

Size	A	B	C	D	E	F	G	H
50	6.720	4.680	2.040	6.750	.625	.890	2.267	—
100	6.741	4.680	2.061	6.750	.625	.890	2.267	—
180	6.801	4.680	2.121	6.750	.875	.890	2.267	—
210	9.688	7.031	2.500	9.250	1.125	.500	2.267	.500
215	10.568	7.440	3.125	9.250	1.375	.500	2.267	.500

Size	J	K	L	M	N	P
50	5.516	2.180	3.250	4.426	0°	3/16 x 3/16
100	5.516	2.180	3.250	4.426	0°	3/16 x 3/16
180	5.516	2.180	3.250	4.426	0°	3/16 x 3/16
210	6.859	2.180	3.250	5.766	20°	1/4 x 1/4
215	6.859	2.180	3.250	5.766	20°	5/16 x 5/16

For standard NEMA frame dimensions, see page 187.

Motor Mount (M) Dimensions (Blue shaded areas indicate GEN 2 design)

For use with 1020, 1040, 20, 20 FBB and 1020 FBC Combinations.

Size	R	S	T	U	V	W	Part No.
50/100	9.250	8.250	10.500	8.000	3.500	.800 x .406	5370-101-078
180	9.250	8.250	10.500	8.000	4.500	.800 x .406	5370-101-079
210/215	11.500	10.500	12.000	9.000	5.250	.750 x .409	5371-101-012

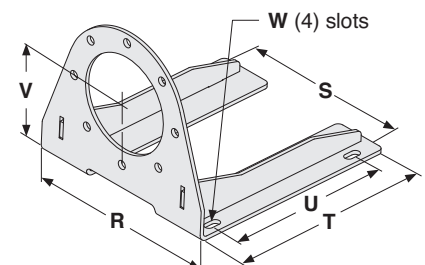

Only 50, 100, and 180 sizes of the models listed will be converted to the new GEN 2 design. 210 and 215 sizes will continue to be offered in the original design and will not be converted.

UM-FBC Series Electrically Released Brakes

UM-2030 FBC Input Clutch/Electrically Released Brake

UM-2030 FBC-B Input Clutch/Electrically Released Brake – Base Mounted

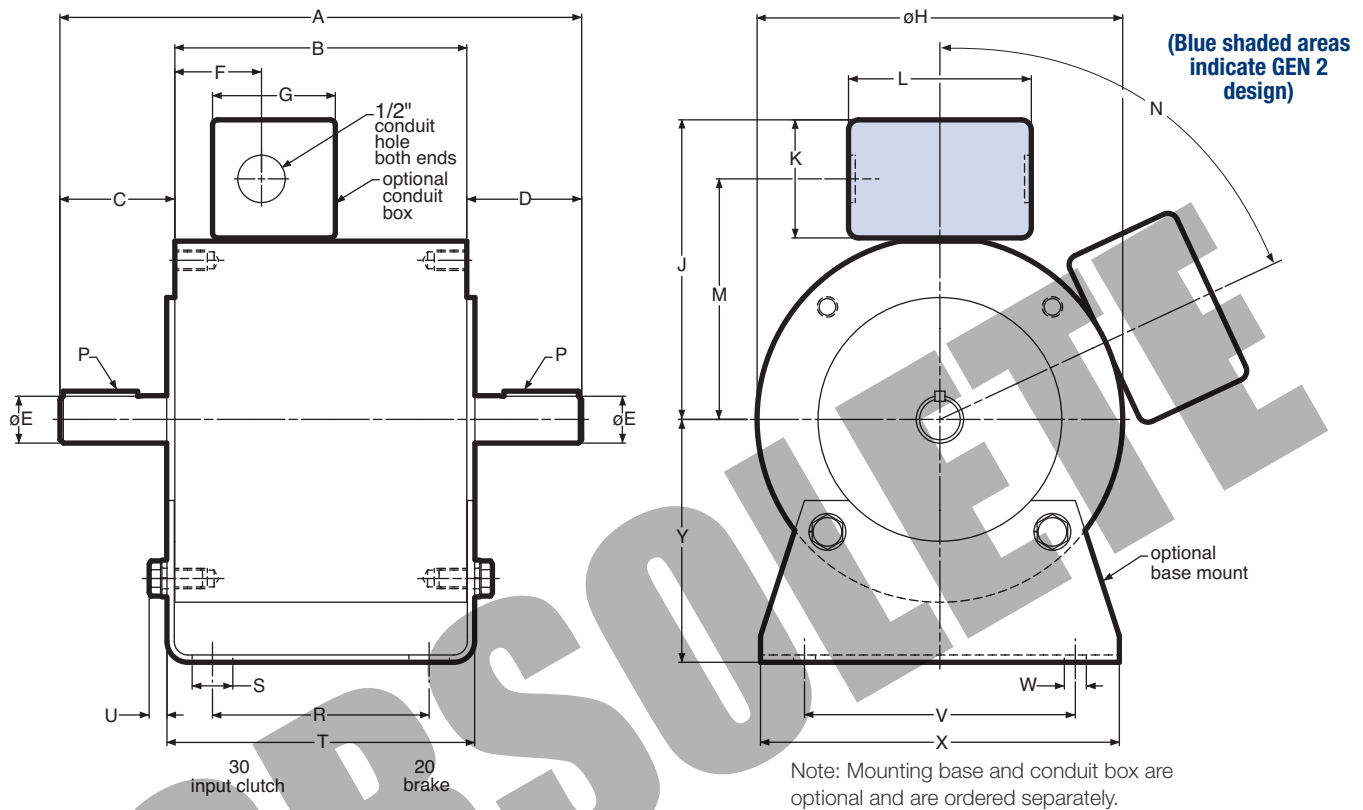

Dimensions (Blue shaded areas indicate GEN 2 design)

Size	A	B	C	D	E	F	G	H	J	K	L	M
50	9.492	5.390	2.062	2.040	.625	1.600	2.267	6.750	5.516	2.180	3.250	4.426
100	9.512	5.390	2.061	2.061	.625	1.600	2.267	6.750	5.516	2.180	3.250	4.426
180	9.632	5.390	2.121	2.121	.875	1.600	2.267	6.750	5.516	2.180	3.250	4.426
210	13.766	8.516	2.500	2.500	1.125	1.812	2.267	9.250	6.859	2.180	3.250	5.766
215	13.766	8.516	2.500	2.500	1.375	1.812	2.267	9.250	6.859	2.180	3.250	5.766

Size	N	P	R	S	T	U	V	W	X	Y
50	0°	3/16 x 3/16	4.000	.800	5.680	.329	5.000	.406	6.000	3.500
100	0°	3/16 x 3/16	4.000	.800	5.680	.329	5.000	.406	6.000	3.500
180	0°	3/16 x 3/16	4.000	.750	5.680	.329	5.000	.406	6.625	4.500
210	65°	1/4 x 1/4	6.000	.750	8.989	.437	7.750	.534	9.000	5.250
215	65°	5/16 x 5/16	6.000	.750	8.989	.437	7.750	.534	9.000	5.250

For standard NEMA frame dimensions, see page 187.

Only 50, 100, and 180 sizes of the models listed will be converted to the new GEN 2 design. 210 and 215 sizes will continue to be offered in the original design and will not be converted.

EUM Series Electrically Released Brakes

Enclosed UniModules Contamination-Proof Design

Clean, quiet, operation. Nothing can get in, nothing can get out. Enclosed design eliminates damage to the working components. Prevents friction wear particles from escaping.

Totally Enclosed Version

The Enclosed UniModule packages the hardworking components from UM products into a totally enclosed housing. This rugged housing keeps wear particles in and contaminants out and provides quiet operation. Pre-burnished at the factory for rated torque directly out-of-box. When enclosed, they are suitable for most industrial applications and tolerate infrequent, light washing.

- Keeps contaminants out
- Keeps wear particles in
- Quiet operation
- Finned for heat dissipation
- UL listed when optional conduit box is installed

To convert any Gen 2 UniModule 50, 100, and 180 sizes to an enclosed model purchase optional Cover Kit

(part number 5370-101-076)

Enclosed UniModule Conversion

Enclosed UniModules, (EUMs) for 50, 100, and 180 sizes, are being replaced by GEN 2 UniModules (UMs) and an easy to install cover kit. Each kit contains (2) vent covers, (2) gaskets and (4) screws. A vent cover bolts to both sides of the UniModule unit to enclose the open vents of the housing creating a totally enclosed (non-washdown) brake package which keeps contaminants out and wear particles in for clean, quiet operation.

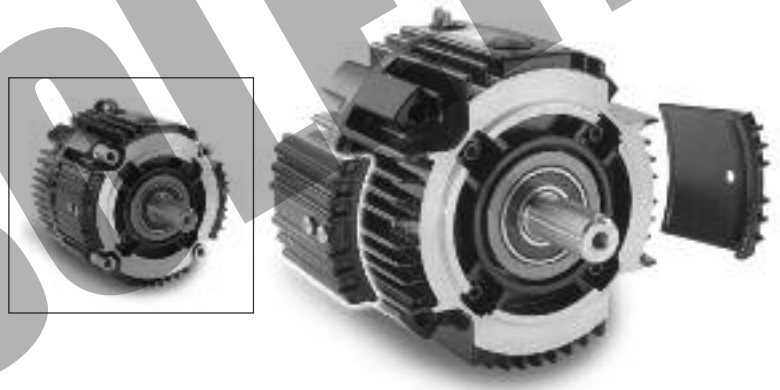

EUM-50

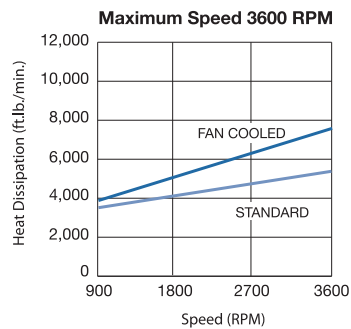

EUM-100/180

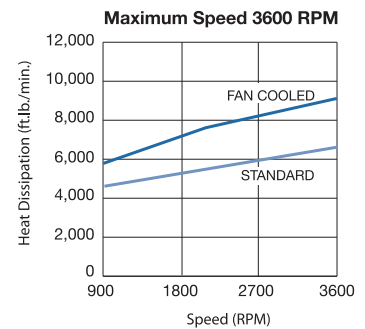

EUM Series Electrically Released Brakes

Preassembled, Totally Enclosed, Electrically Released Brake Units

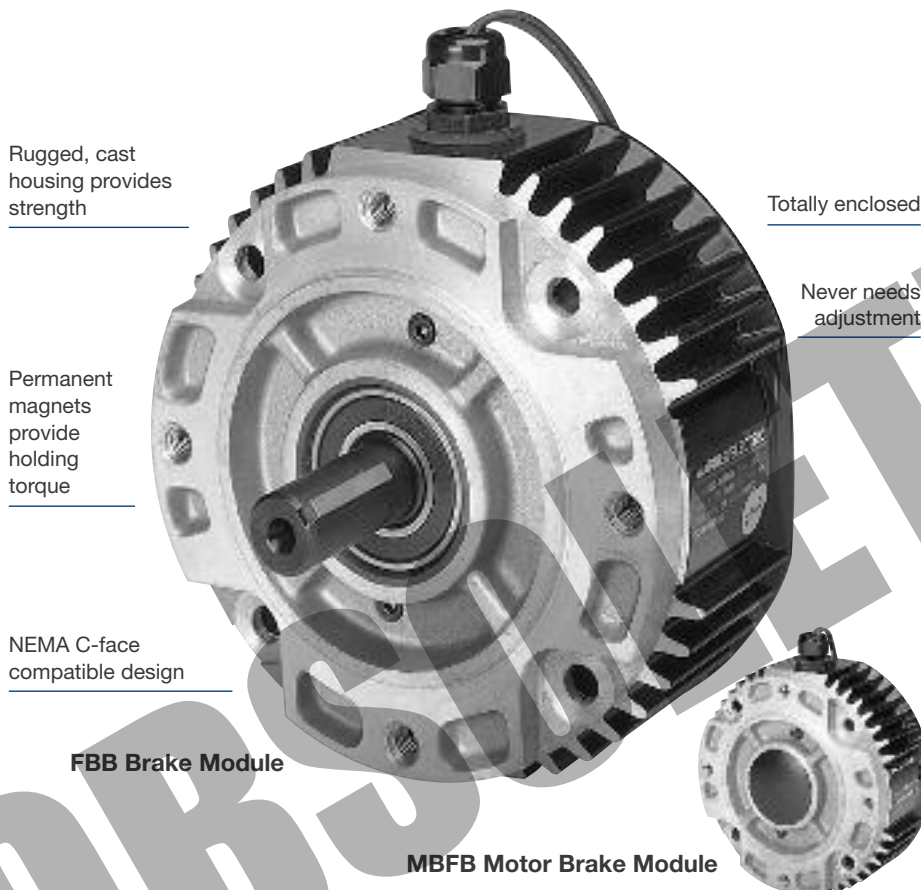

Available in Two Design Styles

EUM-FBB Brake Module

Use for brake alone applications. Mounts between a motor and gear box or reducer. Available in four sizes.

EUM-MBFB Motor Brake Module

Mounts to a double shafted C-face motor. Available in five sizes.

Warner Electric offers the convenience of pre-assembly in UniModule electrically released brake packages. Assembly, alignment, and preburnishing have been done at the factory. Bolt it on, wire it up, and your electrically released brake is ready to go. (Control and conduit box optional)

Care must be exercised to assure proper sizing and selection of electrically released brakes. Motor brakes are used for dynamic stopping and holding of loads when power is removed from the motor. Typical applications include conveyors, process equipment, and lifting devices.

Warner Electric brakes are designed for NEMA C-face motors which match the motor frame size and shaft diameter to the brake. To select a brake, determine the motor frame size and pick an MBFB for double shafted motors or an FBB for mounting between a motor and a gear reducer. Select the torque required for the

application. Higher torque brakes stop loads faster. Lower torque models provide softer stopping to prevent boxes on conveyors from tipping or skidding.

They are sized to provide nominal stopping of a motor in the event of power loss. If your application requires true "Fail safe" braking, the brake must be sized to meet or exceed peak motor torque and placed as close to the load shaft as possible. Peak motor torque can be determined by the formula:

$$\text{Peak Torque} = \frac{(\text{HP} \times 5250)}{\text{Motor Speed}}$$

EUM Series Electrically Released Brakes

EUM-FBB, EUM-MBFB Selection

Warner Electric Electrically Released Enclosed UniModules are available in two styles. The EUM-FBB Brake Module is used in brake only applications and mounts between a C-face motor and a gear box or reducer. The EUM-MBFB Motor Brake Module mounts to the back of a double shafted motor.

Note: Care must be exercised when selecting a brake to ensure it is sized properly for your application.

1. Select Configuration

a. FBB for NEMA C-face Mounting Between a Motor and Reducer

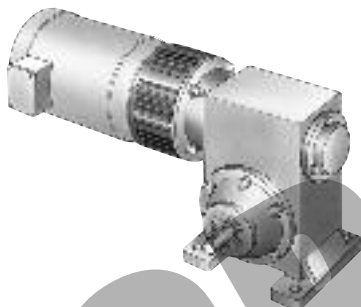

Verify that the brake will be cycled frequently.

Determine the NEMA C-face frame size of your motor and/or reducer, and choose the corresponding size Enclosed UniModule from the Frame Size Selection chart.

Size EUM-100 modules utilize a 5/8" diameter shaft to fit 56C/48Y motor frames with components of EUM-180 units for higher torque and heat dissipation capacity than the EUM-50.

EUM-FBB Frame Size Selection

NEMA Frame Size	EUM Size
56C/48Y	EUM-50* EUM-100**
182C/143TC	EUM-180
184C/145TC	EUM-180
213C/182TC	EUM-210
215C/184TC	EUM-210
213TC/215TC	EUM-215

*For 56C/48Y C-frame motors 3/4 HP and smaller, the EUM-100 size may be used where extended life is desirable.

**The EUM-100 size is recommended for motors 1 HP and larger.

b. MBFB for NEMA C-face Mounting on the Back of a Double Shafted Motor

Verify that the brake will be cycled frequently.

Determine the NEMA C-face frame size of your motor and/or reducer, and choose the corresponding size Enclosed UniModule MBFB from the Frame Size Selection chart, and verify that the motor shaft diameter and mounting bolt circle are the same for the brake and the motor.

Size EUM-100 modules utilize a 5/8" diameter shaft to fit 56C/48Y motor frames with components of EUM-180 units for higher torque and heat dissipation capacity than the EUM-50.

EUM-MBFB Frame Size Selection

NEMA Frame Size	EUM Brake Size	Bolt Hole Mounting Circle	Motor Shaft Dia.
56C/48Y	EUM-50* EUM-100**	5.875	0.625
182C/143TC	EUM-180	5.875	0.875
184C/145TC	EUM-180	5.875	0.875
213C/182TC	EUM-210-7/8	7.25	0.875
215C/184TC	EUM-210	7.25	1.125

*For 56C/48Y C-frame motors 3/4 HP and smaller, the EUM-100 size may be used where extended life is desirable.

**The EUM-100 size is recommended for motors 1 HP and larger.

2. Determine Technical Requirements

Technical considerations for sizing and selection are torque and heat dissipation. Each merits careful consideration, especially heat dissipation as over time, use in excessive temperature environments will have an adverse effect on bearing life and coil wire insulation integrity.

Compare the calculated torque requirement with the average dynamic torque ratings. Select a unit with adequate torque. If the unit selected on torque is different than the unit selected based on heat, select the larger size unit.

Horsepower vs. Shaft Speed

HP	SHAFT SPEED AT CLUTCH (IN RPM)																		
	100	200	300	400	500	600	700	800	900	1000	1100	1200	1500	1800	2000	2400	3000	3600	
1/4	Blue																		
1/2	Blue	Blue													EUM-50				
3/4	Blue	Blue	Blue																
1	Blue	Blue	Blue	Blue							EUM-100/180								
1-1/2	Blue	Blue	Blue	Blue	Blue														
2	Blue	Blue	Blue	Blue	Blue	Blue					EUM-210/215								
3	Blue	Blue	Blue	Blue	Blue	Blue	Blue												
5	Blue	Blue	Blue	Blue	Blue	Blue	Blue	Blue											
7-1/2	Blue	Blue	Blue	Blue	Blue	Blue	Blue	Blue	Blue										
10	Blue	Blue	Blue	Blue	Blue	Blue	Blue	Blue	Blue	Blue									

EUM Series Electrically Released Brakes

a. Heat Dissipation Sizing

Friction surfaces slip during the initial period of engagement and, as a result, heat is generated. The clutch/brake selected must have a heat dissipation rating greater than the heat generated by the application. Therefore, in high inertia or high cycle rate applications, it is necessary to check the heat dissipation carefully. Inertia, speed and cycle rate are the required parameters.

Heat dissipation requirement is calculated as follows:

$$E = 1.7 \times WR^2 \times (N/100)^2 \times F$$

where:

$$E = \text{Heat (lb. ft./min.)}$$

WR^2 = Total reflected inertia at the clutch/brake shaft. Include the clutch/brake output inertia. (lb.ft.²)

N = Speed in revolutions per minute. (RPM)

F = Cycle rate in cycles per minute (CPM)

Compare the calculated heat generated in the application to the unit ratings using the heat dissipation curves. Select the appropriate unit that has adequate heat dissipation ability.

Heat Dissipation Curves

Size 50

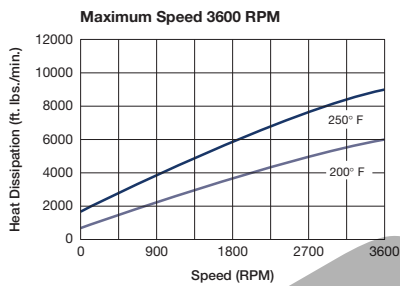

Size 100/180

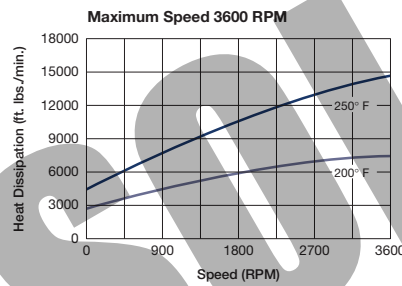

EUM 210/215 (fan not available for 215)

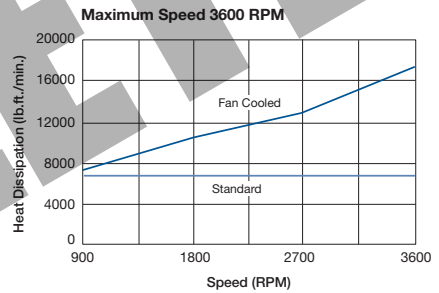

b. Torque Sizing

For most applications, the correct size clutch/brake can be selected from the Horsepower vs. Shaft Speed chart on page 153. Determine the motor horsepower and the RPM at the clutch/brake. The correct size unit is shown at the intersection of horsepower and shaft speed.

If the static torque requirements are known, refer to the technical ratings chart to select a unit.

For some applications, the torque requirement is determined by the time allowed to accelerate and decelerate the load. (This time is generally specified in milliseconds.) For these applications, it is necessary to determine the torque requirement based on load inertia and the time allowed for engagement.

The torque requirements are calculated as follows:

$$T = (WR^2 \times N) / (308 \times t)$$

where:

T = Average Dynamic Torque (lb. ft.)

WR^2 = Total reflected inertia at the clutch/brake shaft. Include the clutch/brake output inertia. (lb. ft.²)

N = Speed in revolutions per minute. (RPM)

t = Time allowed for the engagement (sec)

C-face Electrically Released Brakes Dynamic Torque Curves

Size 50

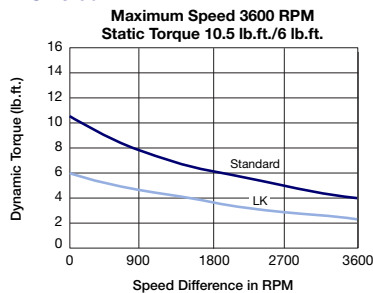

Size 100/180

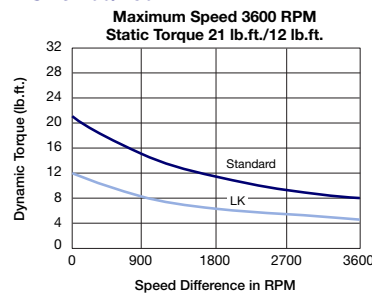

Size 210/215

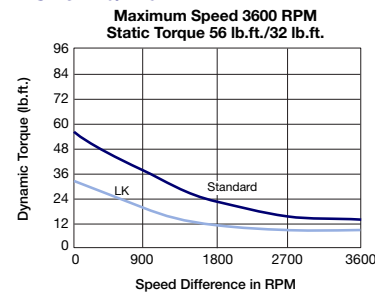

EUM Series Electrically Released Brakes

Preassembled, Totally Enclosed, Electrically Released Brake Units

Specifications

Size	Voltage DC	Static Torque (lb.ft.)	Max. Speed (RPM)	Total Weight (lbs.)	Armature (lb.ft. ²)	Component Inertia –WR ² (lb.ft. ²)				NEMA Frame Size
						FBB		MBFB		
						Hub (lb.ft. ²)	Shaft (lb.ft. ²)	Hub Spliced	Shaft Input	
50	24, 90	6, 10.5	3600	8.6	.009	.001	.0005	.001	.0003	56C/48Y
100	24, 90	12, 21	3600	10.5	.023	.002	.002	.002	.002	56C/48Y
180	24, 90	12, 21	3600	10.5	.023	.002	.002	.002	.002	182C/143TC 184C/145TC
210	90	32, 56	3600	27	.081	.016	.021	.016	.007	213C/182TC 215C/184TC
215	90	32, 56	3600	27	.081	.016	.022	N/A	N/A	213TC/215TC

3. Select Options

Warner Electric Enclosed UniModules can be fitted with several accessories to extend their capacity and ease of mounting.

4. Select Control

All electrically released modules require a control with a potentiometer that will vary brake channel output. For FBB and MBFB brake modules, the CBC-160, CBC-200, CBC-300, or CBC-500/550 is recommended. The FBC units require either a CBC-300 or a CBC 500/550 control.

EUM Series Electrically Released Brakes

Selection/Ordering Information

Selection Procedure

Note: Care must be exercised when selecting the proper brake size for your application.

The selection charts list NEMA motor frame sizes, motor shaft diameters, and the matching FBB or MBFB brakes.

To select a brake:

- Determine the motor NEMA C-face frame size.
- Select brake configuration
 - FBB to mount between a NEMA C-face motor and a gear reducer.
 - MBFB to mount on double shafted NEMA C-face motors.
- Select the brake model from the charts by the torque required - higher torque for faster stopping, lower torque for longer "soft" stopping, Ref: LK Facing. Note: LK facing is only available in 24 volts as a special - contact technical support for assistance.

Note: Size 100 brakes are typically used on motors with a rating of 1 HP or greater.

- Important:** Verify that the motor shaft diameter and mounting bolt circle dimensions are the same for the brake selected and the motor.

Control Selection

An optional conduit box enclosure is available. All electrically released units require a control with a potentiometer to vary brake channel output. For FBB and MBFB brake modules, control models CBC-160, CBC-200, CBC-300, or CBC-500/550 are recommended. (See Controls Section.)

How to Order

- Specify model number and voltage or the corresponding part number.
- Specify conduit box, if desired. See the Controls Section.
- Specify required control unit. See the Controls Section.

Ordering Example

EUM-50-20FBB-6, 90V or 5370-169-983; 5370-101-042 conduit box; CBC-160-2 control.

Totally Enclosed EUM Model No.	Voltage D.C.	Original Design Part No.	COMBINED GEN 2 Part No.		SEPARATE GEN 2 Part Numbers	
			UniModule w/kit	OR	UniModule	and Cover Kit
20 FBB Brake Module - Standard Facing						
EUM-50-20FBB-10	24	N/A	N/A		5370-169-278 and	5370-101-082
EUM-50-20FBB-10	90	5370-169-986	5370-32		5370-169-279 and	5370-101-082
EUM-100-20FBB-21	24	N/A	N/A		5370-169-283 and	5370-101-082
EUM-100-20FBB-21	90	5370-169-992	5370-33		5370-169-284 and	5370-101-082
EUM-180-20FBB-21	24	N/A	N/A		5370-169-288 and	5370-101-082
EUM-180-20FBB-21	90	5370-169-998	5370-34		5370-169-289 and	5370-101-082
EUM-210-20FBB-56	90	5371-169-082	N/A			N/A
EUM-215-20FBB-56	90	5371-169-090	N/A			N/A
20 FBB Brake Module - LK Facing						
EUM-50-20FBB-6	90	5370-169-983	5370-169-260			N/A
EUM-100-20FBB-12	90	5370-169-989	5370-169-261			N/A
EUM-180-20FBB-12	90	5370-169-995	5370-169-262			N/A
EUM-210-20FBB-32	90	5371-169-078	N/A			N/A
EUM-215-20FBB-32	90	5371-169-086	N/A			N/A
20 MBFB Motor Brake Module - Standard Facing						
EUM-50-20MBFB-10	24	N/A	N/A		5370-169-248 and	5370-101-082
EUM-50-20MBFB-10	90	5370-169-968	5370-35		5370-169-249 and	5370-101-082
EUM-100-20MBFB-21	24	N/A	N/A		5370-169-253 and	5370-101-082
EUM-100-20MBFB-21	90	5370-169-974	5370-36		5370-169-254 and	5370-101-082
EUM-180-20MBFB-21	24	N/A	N/A		5370-169-258 and	5370-101-082
EUM-180-20MBFB-21	90	5370-169-980	5370-37		5370-169-259 and	5370-101-082
EUM-210-7/8-20MBFB-56	90	5371-169-068	N/A			N/A
EUM-210-20MBFB-56	90	5371-169-060	N/A			N/A
20 MBFB Motor Brake Module- LK Facing						
EUM-50-20MBFB-6	90	5370-169-965	5370-169-263			N/A
EUM-100-20MBFB-12	90	5370-169-971	5370-169-264			N/A
EUM-180-20MBFB-12	90	5370-169-977	5370-169-265			N/A
EUM-210-7/8-20MBFB-32	90	5371-169-064	N/A			N/A
EUM-210-20MBFB-32	90	5371-169-056	N/A			N/A

Accessories

Description	FBB Size	Part No.
Conduit Box	FBB series	5370-101-042
	All sizes	
Motor Mount Kit for 20 FBB	50/100/180	5370-101-079
	210/215	5371-101-012

EUM-FBB Series Electrically Released Brakes

EUM-FBB Brake Module

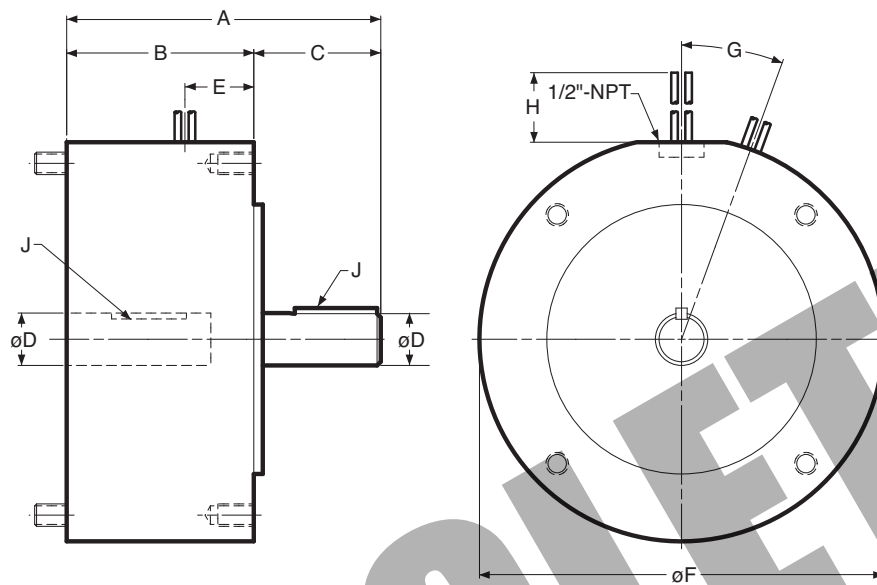

Dimensions (Blue shaded areas indicate GEN 2 design)

Size	A	B	C	D	E	F	G	H	J
50	5.165	3.125	2.040	.625	1.150	6.750	0°	36	3/16 x 3/16
100	5.186	3.125	2.061	.625	1.150	6.750	0°	36	3/16 x 3/16
180	5.246	3.125	2.121	.875	1.150	6.750	0°	36	3/16 x 3/16
210	7.578	4.609	2.500	1.125	1.812	9.250	20°	36	1/4 x 1/4
215	8.078	4.609	3.000	1.375	1.812	9.250	20°	36	5/16 x 5/16

For standard NEMA frame dimensions, see page 187.

Only 50, 100, and 180 sizes of the models listed will be converted to the new GEN 2 design. 210 and 215 sizes will continue to be offered in the original design and will not be converted.

EUM-MBFB Series Electrically Released Brakes

EUM-MBFB Motor Brake Module

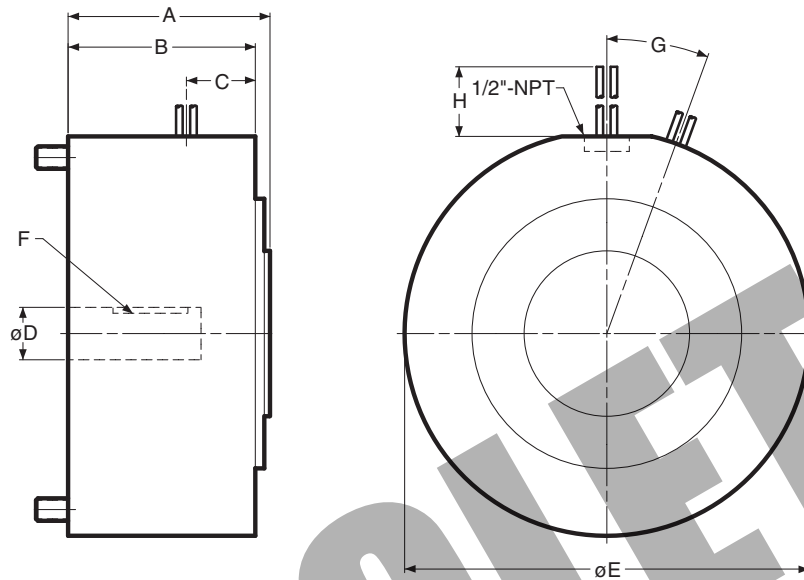

Dimensions (Blue shaded areas indicate GEN 2 design)

Size	A	B	C	D	E	F	G	H
50	3.368	3.125	1.150	.625	6.750	3/16 x 3/16	0°	36
100	3.368	3.125	1.150	.625	6.750	3/16 x 3/16	0°	36
180	3.368	3.125	1.150	.875	6.750	3/16 x 3/16	0°	36
210 7/8	5.150	4.610	1.812	.875	9.250	3/16 x 3/16	20°	36
210	5.150	4.610	1.812	1.125	9.250	1/4 x 1/4	20°	36

For standard NEMA frame dimensions, see page 187.

Only 50, 100, and 180 sizes of the models listed will be converted to the new GEN 2 design.
210 size will continue to be offered in the original design and will not be converted.

EM Series Electrically Released Brakes

For Dynamic Stopping and Cycling Applications

Warner Electric's modular design brakes and clutch/brake units offer material handling system users a high performance alternative to spring-set brakes. These modular units provide long life, maintenance free operation, and consistent performance with minimal downtime.

These brakes are offered in power-off types for double shaft motors and for installation between C-face motor and reducer or other drive device. Powerful permanent magnets generate braking torque. The brakes release when voltage is applied to the coil, countering the force of the permanent magnets. No power is required to stop or hold a load. An optional integral conduit box provides simple wiring direct from the motor power leads.

- Designed for dynamic stopping operations
- Brake automatically engages when power is turned off
- High cycle rate capability
- Never needs adjustment – automatically compensates for wear
- Powerful permanent magnets provide braking force
- Choice of open or enclosed brakes
- Prepackaged, preburnished UM version

Three C-face Compatible Designs

The UM Series (UniModule Clutch/Brakes) are preassembled clutch/electrically released brake modules.

- The UM-1020-FBC brake/motor clutch combination is used for clutch/power-off brake applications. It mounts directly to C-face compatible components.
- The UM-2030-FBC brake/input clutch combination is used for clutch/power-off brake applications. It has shafts on both the input and output sides for base mounting.

The EUM Series (Enclosed Motor Brakes) are totally enclosed non-vented units that keep wear particles in and contaminants out.

- The EUM-FBB brake unit can be mounted between two C-face compatible components.
- The EUM-MBFB motor brake is mounted directly to the rear of a double-shafted motor.

The EM Series (Electro Module Brakes and Clutch/Brakes) are comprised of individual units that may bolt together to form various combinations:

- The EM-FBB brake module mounts between a C-face motor and a gear box or reducer.
- The EM-MBFB motor brake module is mounted to the rear of a double-shafted motor.
- The EM-FBC brake module is used in combination with a motor clutch or input clutch unit to make a clutch/electrically released brake or can be used alone as a brake only.

Brake Modules (FBB) – For mounting between a C-face motor and a gearbox or reducer

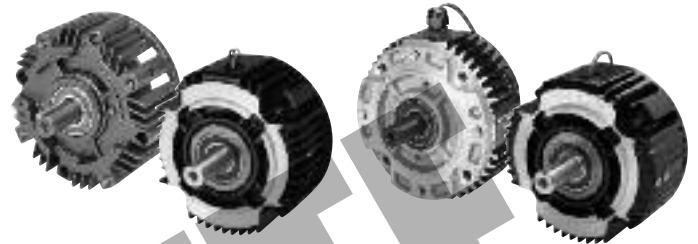

EM Series
Shaft mounted,
vented housing

EUM Series
Shaft mounted,
totally enclosed
non-vented housing

Use for brake alone applications.

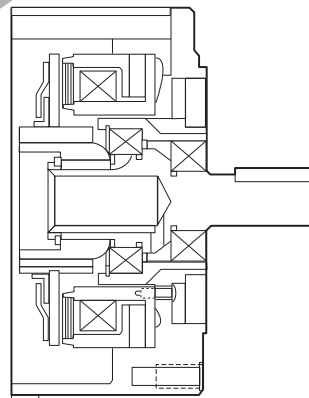

Features

- Single armature for brake alone applications
- Output shaft
- Permanent magnets
- UL listed

EM-FBB

Available in 5 sizes

EUM-FBB

Available in 5 sizes

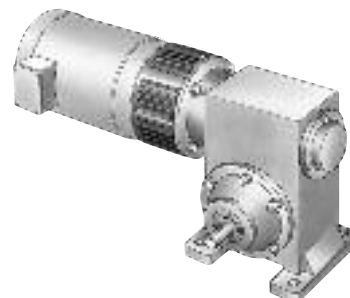

EM-FBB Electro Module
brake unit between a
motor and a reducer.

EM Series Electrically Released Brakes

Electro Module, Electrically Released Brakes and Clutch/Brake Units for Dynamic Stopping and Cycling Applications 210 and 215 sizes

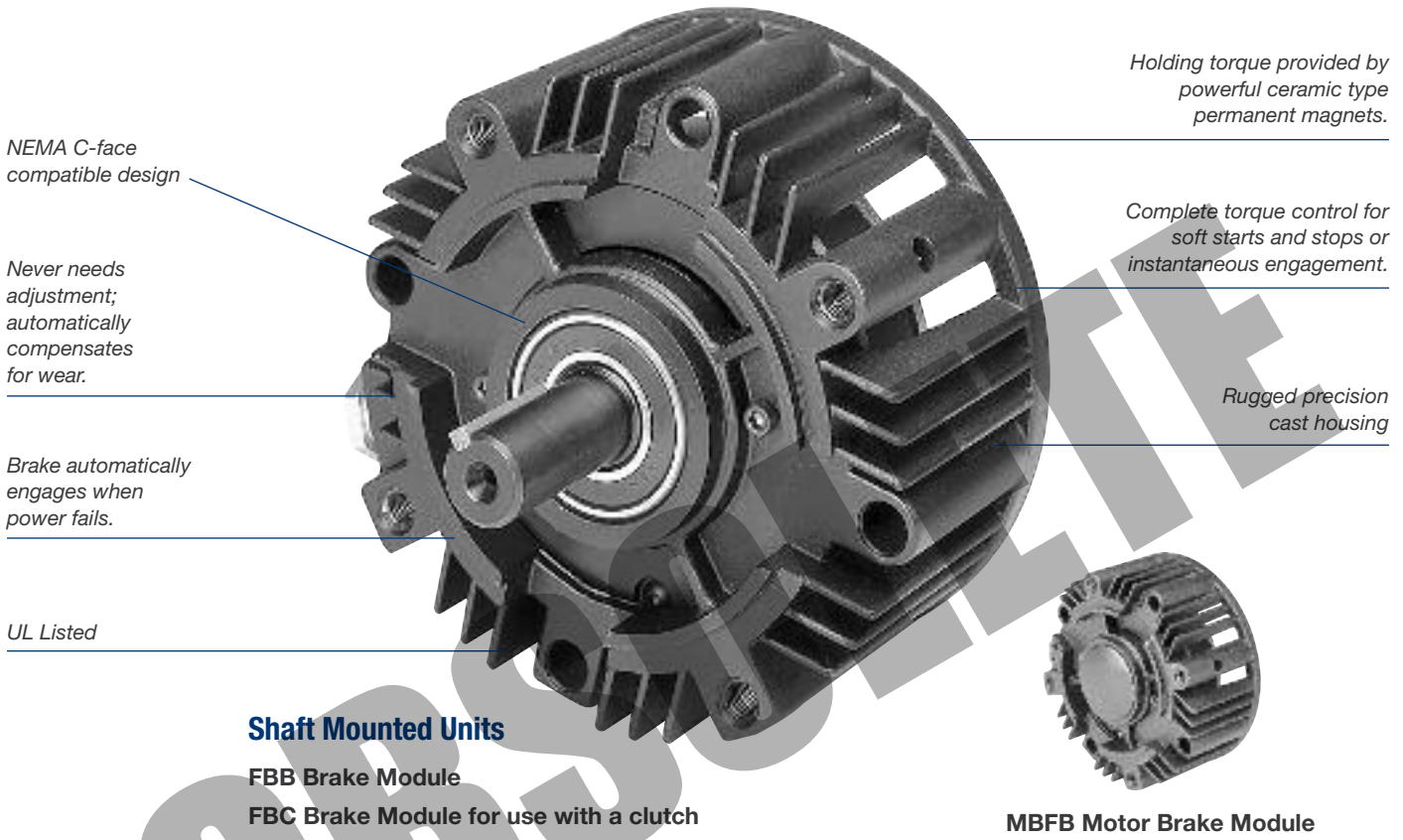

Shaft Mounted Units

- FBB Brake Module
- FBC Brake Module for use with a clutch

MBFB Motor Brake Module

Warner Electric's unique design employs powerful permanent magnets for maximum torque when power is removed from the brake coil. A small amount of electrical power applied to the brake coil nullifies the permanent magnets' force and the brake releases. No springs to limit cycle rates. Never need adjustment. No lubrication. These brakes are recommended for dynamic cycling operations only.

Available in Three Design Styles

EM-FBB Brake Module
Use for brake alone applications. Mounts between a C-face motor and a gear box or reducer. Available in five sizes.

EM-MBFB Motor Brake Module
Mounts to the back of a double shafted motor. Available in four sizes.

EM-FBC Brake Module for use with a Clutch
Combine with a motor or input clutch for clutch/brake applications. Three sizes are available.

Specifications

Size	Voltage DC	Static Torque (lb.ft.)		Max. Speed (RPM)	Total Weight (lbs.)	Component Inertia –WR ² (lb.ft. ²)				NEMA Frame Size
		Brake	Clutch			Armature		Hub	Shaft	
						FBB/MBFB	FBC			
EM-50	24 90	10.5	16	3600	8.6	.0071	.014	.003	.001	56C/48Y
EM-100	90	21	—	3600	10.5	.018	—	.004	.002	56C/48Y
EM-180	24 90	21	30	3600	10.5	.018	.036	.004	.002	182C/143TC 184C/145TC
EM-210	24 90	56	95	3600	27	.081	.162	.027	.017	213C/182TC 215C/184TC

EM Series Electrically Released Brakes

C-face Compatible Brakes and Clutch/Brakes

Motor Brake Modules (MBFB)

For mounting directly to the rear of a double-shafted motor



EM Series
vented housing

EUM Series
totally enclosed
non-vented
housing

Use as a motor brake on C-face type motors.

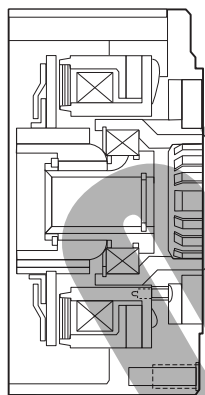

Features

- Single armature design
- Complete torque control
- Precision cast housing
- Ceramic type permanent magnets

EM-MBFB

Available in 5 sizes

EUM-MBFB

Available in 5 sizes

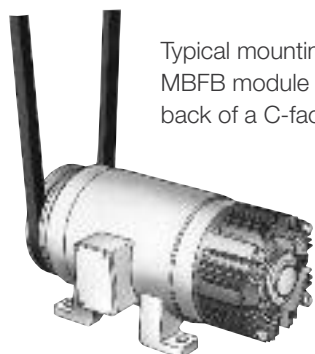

Typical mounting of an MBFB module on the back of a C-face motor

Clutch/Brake Modules (FBC)

Clutch/Fail-safe brake for mounting between a C-face motor and a gearbox or reducer



EM Series
Modular unit with
C/B capability

UM Series
Fully assembled
C/B combination
package

Combine with a motor or input clutch for clutch/brake applications or use alone as a brake only.

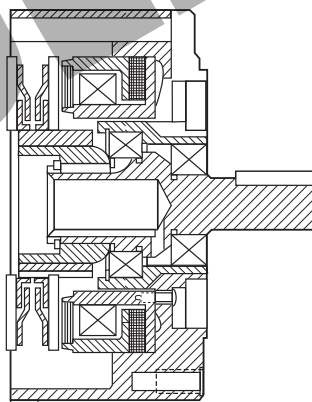

Features

- Dual armature for clutch/brake combination
- Output shaft
- Can be base mounted for use as a separate drive unit.

EM-FBC

Available in 4 sizes

UM-FBC

Available in 5 size combinations

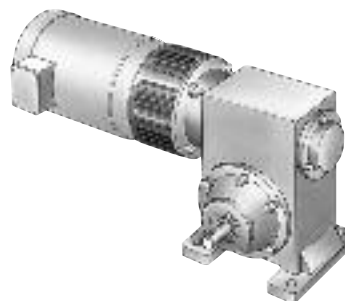

EM-FBC Electro Module brake unit combined with a motor clutch module

UM-FBC UniModule clutch/brake mounted on a base

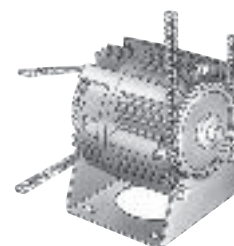

EM Series Electrically Released Brakes

EM-FBB, EM-FBC, EM-MBFB Selection

Warner Electric Electrically Released Electro Modules are available in three styles. The EM-FBB Brake Module is used in brake only applications and mounts between a C-face motor and a gear box or reducer. The EM-MBFB Motor Brake Module mounts to the back of a double shafted motor. The EM-FBC Brake Module is combined with a motor clutch (EM-10) or an input clutch (EM-30) for clutch/electrically released brake applications.

Note: Care must be exercised when selecting a brake to ensure it is sized properly for your application.

1. Select Configuration

a. For FBB and MBFB Modules NEMA C-face Mounting

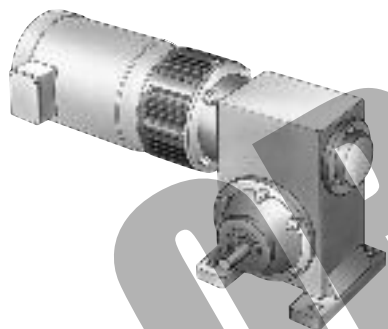

Verify that the brake will be cycled frequently.

Determine the NEMA C-face frame size of your motor and/or reducer, and choose the corresponding size Electro Module from the Frame Size Selection chart.

Size EM-100 modules utilize a 5/8" diameter shaft to fit 56C/48Y motor frames with components of EM-180 units for higher torque and heat dissipation capacity than the EM-50.

Select Brake Configuration: use an EM-FBB for mounting between a motor and a reducer; or an EM-MBFB for mounting on the rear of a double shafted motor.

NOTE: When selecting an MBFB, ensure the shaft dimensions on the rear of the motor are compatible with the EM-MBFB unit selected.

b. For FBC Modular Units, NEMA C-face Mounting

Verify that brake will be cycled frequently, and will be used with a motor mounted clutch (EM-10) for C-face mounting.

Determine the NEMA C-face frame size of your motor and/or reducer, and choose the corresponding size Electro Module from the Frame Size Selection chart.

FBC Frame Size Selection

NEMA Frame Size	EM Size
56C/48Y	EM-50* EM-100**
182C/143TC 184C/145TC	EM-180
213C/182TC 215C/184TC	EM-210

For torque ratings, refer to the "Specifications" chart. Note that separate torque ratings are listed for the clutch and brake segments of the module.

* For 56C/48Y C-frame motors 3/4 HP and smaller, the EM-100 size may be used where extended life is desirable.

** The EM-100 size is recommended for motors 1 HP and larger.

c. For FBC Modular Units, Base Mounting

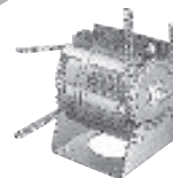

Verify that brake will be cycled frequently, and will be used with an input clutch (EM-30) for base mounting.

Select the correct size module from the Horsepower vs. Shaft Speed chart (at the bottom of this page) by determining the motor horsepower and RPM at the module location. The correct size EM is shown at the intersection of the HP and operating speed. For additional sizing information, refer to the technical sizing procedure (step 2).

FBB AND MBFB Frame Size Selection

NEMA Frame Size	EM Size
56C/48Y	EM-50* EM-100**
182C/143TC 184C/145TC	EM-180
213C/182TC 215C/184TC	EM-210
213TC/215TC	EM-215

*For 56C/48Y C-frame motors 3/4 HP and smaller, the EM-100 size may be used where extended life is desirable.

**The EM-100 size is recommended for motors 1 HP and larger.

Horsepower vs. Shaft Speed

HP	SHAFT SPEED AT CLUTCH (IN RPM)																		
	100	200	300	400	500	600	700	800	900	1000	1100	1200	1500	1800	2000	2400	3000	3600	
1/4																			
1/2														EM-50					
3/4																			
1																			
1-1/2														EM-100 or EM-180					
2																			
3																			
5																			
7-1/2																			

2. Determine Technical Requirements

Technical considerations for sizing and selection are torque and heat dissipation. Each merits careful consideration, especially heat dissipation as over time, use in excessive temperature environments will have an adverse effect on bearing life and coil wire insulation integrity.

Compare the calculated torque requirement with the average dynamic torque ratings. Select a unit with adequate torque. If the unit selected on torque is different than the unit selected based on heat, select the larger size unit.

a. Heat Dissipation Sizing

Friction surfaces slip during the initial period of engagement and, as a result, heat is generated. The clutch/brake selected must have a heat dissipation rating greater than the heat generated by the application. Therefore, in high inertia or high cycle rate applications, it is necessary to check the heat dissipation carefully. Inertia, speed and cycle rate are the required parameters.

Heat dissipation requirement is calculated as follows:

$$E = 1.7 \times WR^2 \times (N/100)^2 \times F$$

where:

$$E = \text{Heat (lb. ft./min.)}$$

WR^2 = Total reflected inertia at the clutch/brake shaft. Include the clutch/brake output inertia. (lb.ft.²)

N = Speed in revolutions per minute. (RPM)

F = Cycle rate in cycles per minute (CPM)

Compare the calculated heat generated in the application to the unit ratings using the heat dissipation curves. Select the appropriate unit that has adequate heat dissipation ability.

Heat Dissipation Curves

Size 50

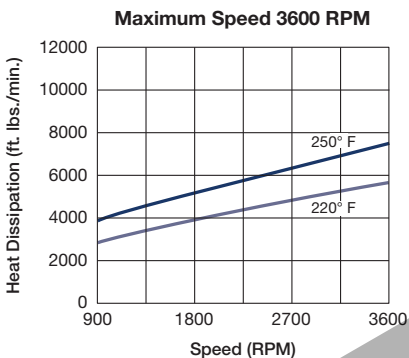

Size 100/180

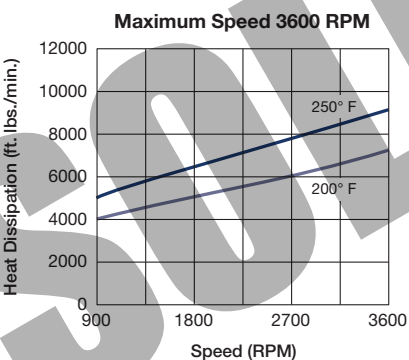

Size 210/215

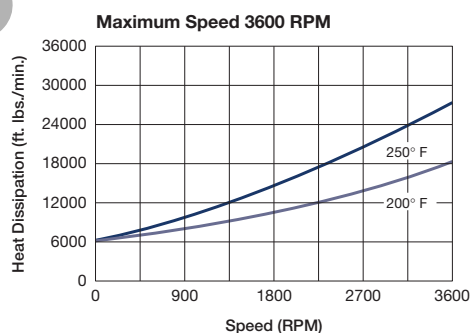

b. Torque Sizing

For most applications, the correct size clutch/brake can be selected from the Horsepower vs. Shaft Speed chart on page 162. Determine the motor horsepower and the RPM at the clutch/brake. The correct size unit is shown at the intersection of horsepower and shaft speed.

If the static torque requirements are known, refer to the technical ratings chart to select a unit.

For some applications, the torque requirement is determined by the time allowed to accelerate and decelerate the load. (This time is generally specified in milliseconds.) For these applications, it is necessary to determine the torque requirement based on load inertia and the time allowed for engagement.

The torque requirements are calculated as follows:

$$T = (WR^2 \times N) / (308 \times t)$$

where:

$$T = \text{Average Dynamic Torque (lb. ft.)}$$

WR^2 = Total reflected inertia at the clutch/brake shaft. Include the clutch/brake output inertia. (lb. ft.²)

N = Speed in revolutions per minute (RPM)

t = Time allowed for the engagement (sec)

EM Series Electrically Released Brakes

Ordering Information

C-face Electrically Released Brakes Dynamic Torque Curves

Size 50

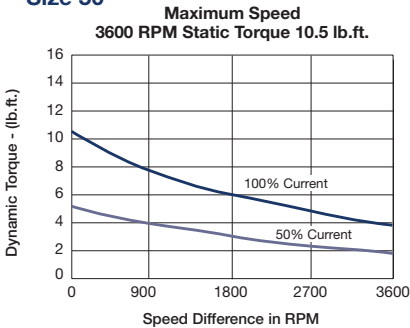

Size 100/180

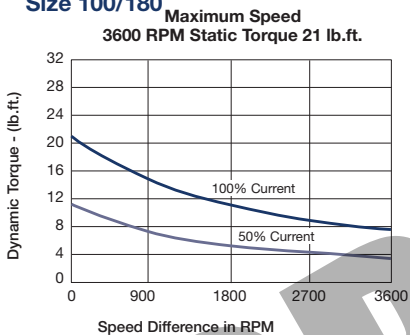

Size 210/215

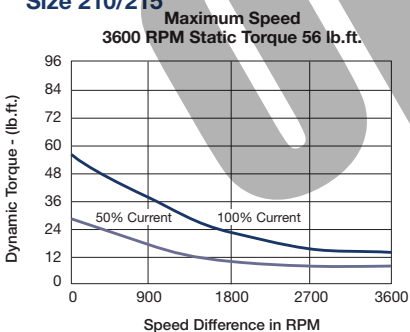

3. Select Accessories

Warner Electric Electro Modules can be fitted with several accessories to extend their capacity and ease of mounting.

4. Select Control

All electrically released modules require a control with a potentiometer that will vary brake channel output. For FBB and MBFB brake modules, the CBC-160, CBC-200, CBC-300, or CBC-500/550 is recommended. The FBC units require either a CBC-300 or a CBC 500/550 control.

How to Order

1. Specify model number and voltage or the corresponding part number.
2. Specify conduit box, if desired.
3. Specify required control. See the Controls Section (page 201).

Ordering Example

EM-50-20FBB, 90V or 5370-169-234;
5370-101-042 conduit box;
CBC-160-2 control.

Part Numbers (Blue shaded areas indicate GEN 2 design)

Model No.	Voltage DC	GEN 2 Part No.	Original Part No.
FBB Brake Module for use as brake only			
EM-50-20FBB	24	5370-169-278	5370-169-066
EM-50-20FBB	90	5370-169-279	5370-169-058
EM-100-20FBB	24	5370-169-283	5370-169-020
EM-100-20FBB	90	5370-169-284	5370-169-084
EM-180-20FBB	24	5370-169-288	5370-169-068
EM-180-20FBB	90	5370-169-289	5370-169-059
EM-210-20FBB	24		5371-169-032
EM-210-20FBB	90		5371-169-029
EM-215-20FBB	24		5371-169-100
EM-215-20FBB	90		5371-169-054
FBC Brake Module for use with EM clutch			
EM-50-20FBC	24	5370-169-233	5370-169-065
EM-50-20FBC	90	5370-169-234	5370-169-056
EM-100-20FBC	24	5370-169-238	5370-169-109
EM-100-20FBC	90	5370-169-239	5370-169-108
EM-180-20FBC	24	5370-169-243	5370-169-067
EM-180-20FBC	90	5370-169-244	5370-169-057
EM-210-20FBC	24		5371-169-031
EM-210-20FBC	90		5371-169-028
MBFB Motor Brake Module			
EM-50-20MBFB	24	5370-169-248	5370-169-063
EM-50-20MBFB	90	5370-169-249	5370-169-060
EM-100-20MBFB	24	5370-169-253	5370-169-007
EM-100-20MBFB	90	5370-169-254	5370-169-085
EM-180-20MBFB	24	5370-169-258	5370-169-069
EM-180-20MBFB	90	5370-169-259	5370-169-061
EM-210-7/8-20MBFB	24		5371-169-101
EM-210-7/8-20MBFB	90		5371-169-072
EM-210-20MBFB	24		5371-169-033
EM-210-20MBFB	90		5371-169-030

Accessories

Description	EM Size	Part No.
Conduit Box	EM series All sizes	5370-101-042
Base Mount Kit for 2030 FBC	50/100	5370-101-004
	180	5370-101-002
	210/215	5371-101-019
Motor Mount Kit for 20 FBB, 1020 FBC	50/100	5370-101-078
	180	5370-101-079
	210/215	5371-101-012
Cover Kit	50/100/180	5370-101-076
	50/180 (FBB or MBFB)	5370-101-082

EM-FBB Series Electrically Released Brakes

EM-20 FBB Brake Module

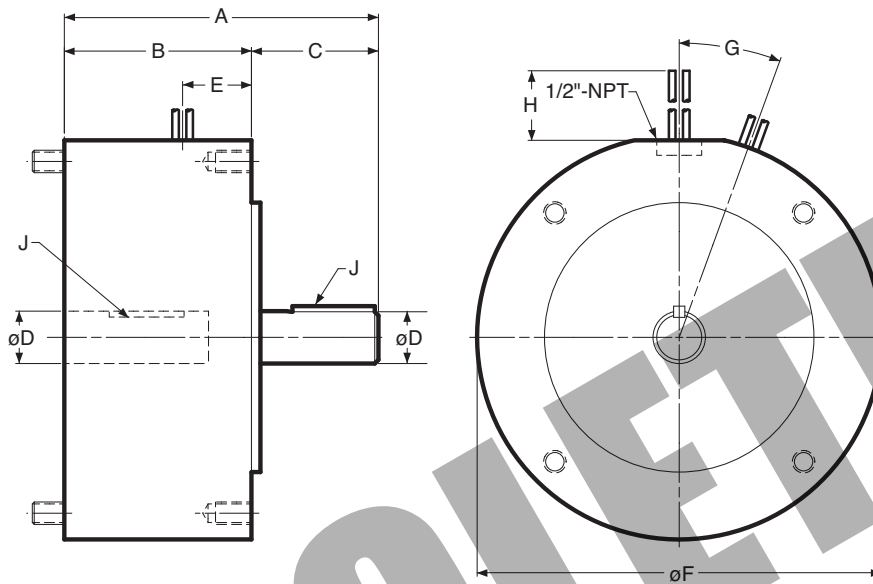

Dimensions (Blue shaded areas indicate GEN 2 design)

Size	A	B	C	D	E	F	G	H	J
50	5.165	3.125	2.040	.625	1.150	6.750	0°	36	3/16 x 3/16
100	5.186	3.125	2.061	.625	1.150	6.750	0°	36	3/16 x 3/16
180	5.246	3.125	2.121	.875	1.150	6.750	0°	36	3/16 x 3/16
210	7.578	4.609	2.500	1.125	1.812	9.250	20°	36	1/4 x 1/4
215	8.078	4.609	3.000	1.375	1.812	9.250	20°	36	5/16 x 5/16

For standard NEMA frame dimensions, see page 187.

Only 50, 100, and 180 sizes of the models listed will be converted to the new GEN 2 design. 210 and 215 sizes will continue to be offered in the original design and will not be converted.

EM-FBC Series Electrically Released Brakes

EM-20FBC Brake Module for use with a Clutch

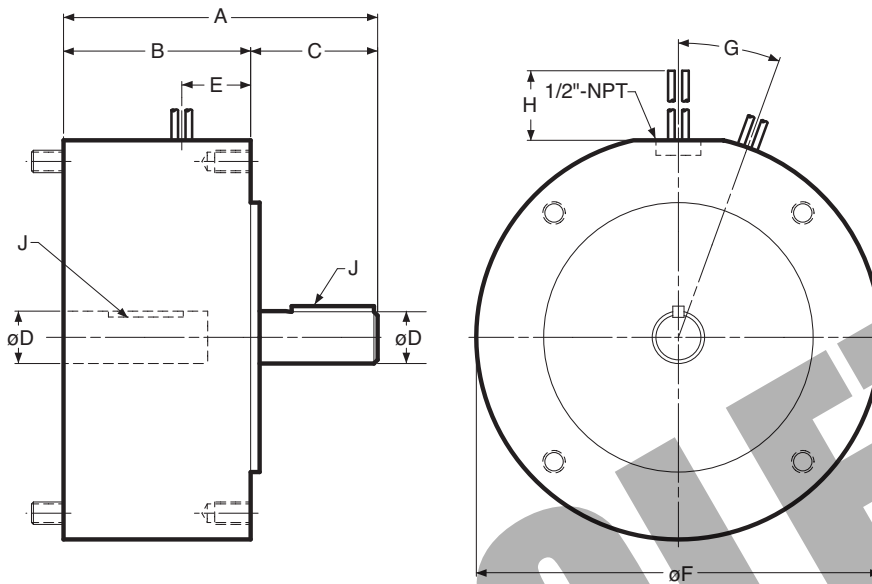

Dimensions (Blue shaded areas indicate GEN 2 design)

Size	A	B	C	D	E	F	G	H	J	K
50	5.165	3.125	2.040	.625	1.150	6.750	0°	36	3/16 x 3/16	—
100	5.186	3.125	2.061	.625	1.150	6.750	0°	36	3/16 x 3/16	—
180	5.246	3.125	2.121	.875	1.150	6.750	0°	36	3/16 x 3/16	—
210	7.578	4.609	2.500	1.125	1.812	9.250	20°	36	1/4 x 1/4	.785

For standard NEMA frame dimensions, see page 187.

Only 50, 100, and 180 sizes of the models listed will be converted to the new GEN 2 design. 210 size will continue to be offered in the original design and will not be converted.

EM-MBFB Series Electrically Released Brakes

EM-20 MBFB Motor Brake Module

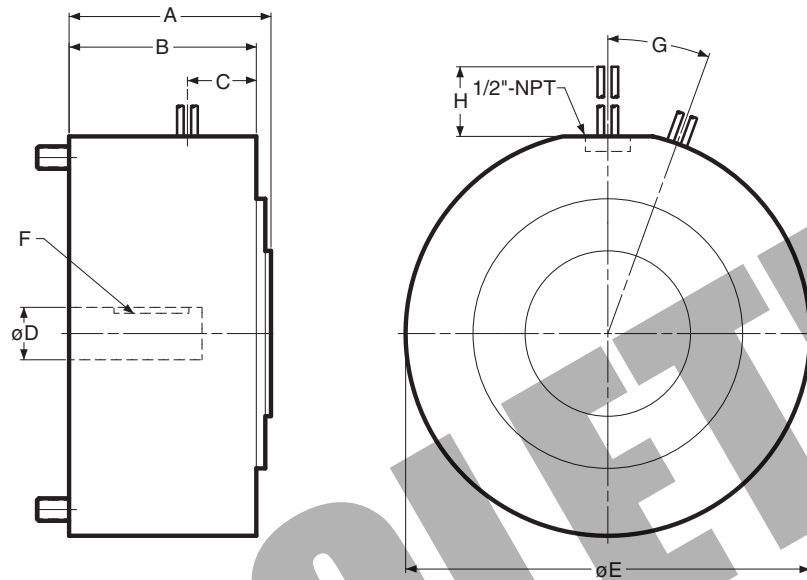

Dimensions (Blue shaded areas indicate GEN 2 design)

Size	A	B	C	D	E	F	G	H
50	3.368	3.125	1.150	.625	6.750	3/16 x 3/16	0°	36
100	3.368	3.125	1.150	.625	6.750	3/16 x 3/16	0°	36
180	3.368	3.125	1.150	.875	6.750	3/16 x 3/16	0°	36
210 7/8	5.150	4.610	1.812	.875	9.250	3/16 x 3/16	20°	36
210	5.150	4.610	1.812	1.125	9.250	1/4 x 1/4	20°	36

For standard NEMA frame dimensions, see page 187.

Only 50, 100, and 180 sizes of the models listed will be converted to the new GEN 2 design.
210 size will continue to be offered in the original design and will not be converted.

Enclosed Electro Modules Electrically Released Brakes

Contamination-Proof Design

Clean, quiet, operation. Nothing can get in, nothing can get out. Enclosed design eliminates damage to the working components. Prevents friction wear particles from escaping.

Totally Enclosed Version

The Enclosed Electro Module packages the hardworking components from EM products into a totally enclosed housing. This rugged housing keeps wear particles in and contaminants out and provides quiet operation. Pre-burnished at the factory for rated torque directly out-of-box. When enclosed, they are suitable for most industrial applications and tolerate infrequent, light washing.

- Keeps contaminants out
- Keeps wear particles in
- Quiet operation
- Finned for heat dissipation
- UL listed when optional conduit box is installed

To convert any Gen 2 Electro Module 50, 100, and 180 sizes to an enclosed model purchase optional Cover Kit

(part number 5370-101-076)

(part number 5370-101-082 for brake only)

Enclosed Electro Module Conversion (10-20FBC, 20-30FBC)

An optional cover kit (part number 5370-101-076) can be purchased separately to enclose the open vents in the housing. Each cover kit includes two vent covers, two gaskets and four screws needed to convert a vented Electro Module to an enclosed design (non-washdown).

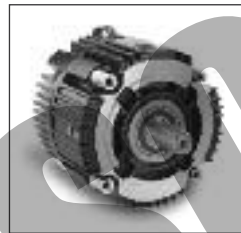

Enclosed Electro Module-Brake Only (20FBB or 20MBFB)

An optional cover kit (part number 5370-101-082) can be purchased separately to enclose the open vents in the housing and a cover plate to close off the back of the module. Each cover kit includes two vent covers, two gaskets, four screws and one cover plate needed to convert a vented Electro Module 20 to an enclosed design (non-washdown).



Enclosed Electro Modules Electrically Released Brakes

GEN 2 Heat Dissipation Curves

EUM-50

Maximum Speed 3600 RPM

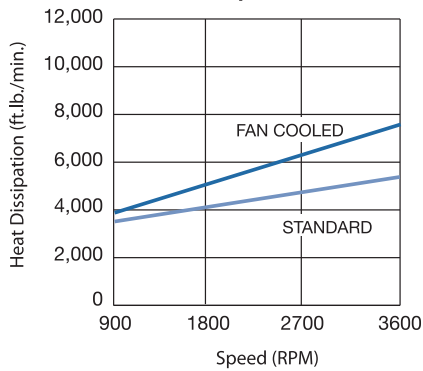

EUM-100/180

Maximum Speed 3600 RPM

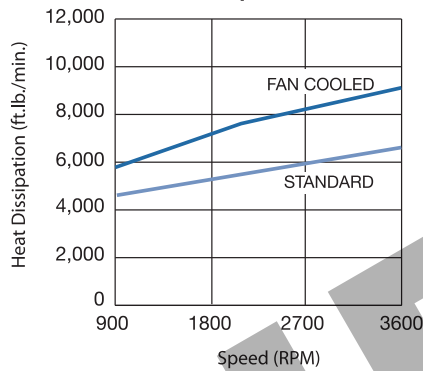

Note: For ORIGINAL DESIGN EUM 50,100 and 180 curves, see page 62.

How To Order

Some GEN 2 EUM models can be ordered in the following two ways:

1. Combined part number, UniModule including cover kit (ex. 5370-15)
2. Separate part numbers, UniModule and cover kit (ex. 5370-273-201 and 5370-101-076)

Totally Enclosed EUM Model No.	Voltage D.C.	Original Design Part No.	OR	
			COMBINED GEN 2 Part No. UniModule w/kit	SEPARATE GEN 2 Part Numbers UniModule and Cover Kit
EUM Series				
EUM-50-20FBB-6	90	5370-169-983	5370-169-260	N/A
EUM-100-20FBB-12	90	5370-169-989	5370-169-261	N/A
EUM-180-20FBB-12	90	5370-169-995	5370-169-262	N/A
EUM-50-20MBFB-6	90	5370-169-965	5370-169-263	N/A
EUM-100-20MBFB-12	90	5370-169-971	5370-169-264	N/A
EUM-180-20MBFB-12	90	5370-169-977	5370-169-265	N/A
EUM-50-20FBB-10	90	5370-169-986	5370-32	5370-169-279 and 5370-101-082
EUM-100-20FBB-21	90	5370-169-992	5370-33	5370-169-284 and 5370-101-082
EUM-180-20FBB-21	90	5370-169-998	5370-34	5370-169-289 and 5370-101-082
EUM-50-20MBFB-10	90	5370-169-968	5370-35	5370-169-249 and 5370-101-082
EUM-100-20MBFB-21	90	5370-169-974	5370-36	5370-169-254 and 5370-101-082
EUM-180-20MBFB-21	90	5370-169-980	5370-37	5370-169-259 and 5370-101-082

UNIBRAKE AC Motor Brakes

Warner Electric UNIBRAKE® decelerates or holds loads when power is off

C-Face, Power-Off Brakes

Single C-Face Power-Off Brakes are designed to decelerate or hold inertia loads when the power is turned off. The single C-Face mounts on the non-driven end of a motor. Brakes are available from 3 ft. lb. to 15 ft. lb.

C-Face, Power-Off Brakes with Heavy-Duty Enclosures

Our Single C-Face Power-Off Brake is also available with cast iron housing for applications involving corrosive environments. The heavy-duty housing also includes o-ring seals to create a dust-tight brake. Brakes are available from 3 ft. lb. to 15 ft. lb.

Double C-Face, Power-Off Brakes

The Double C-Face Brake is designed for use as a coupler between standard C-Face motors and C-Face gear reducers.



UNIBRAKE is available to meet the demands of a wide variety of applications



Applications

The motor brakes are commonly used as parking brakes to hold a load in place or as stopping brakes to dynamically decelerate a load.

Applications include:

- Material Handling
- Food Processing
- Machine Tools

Simple design with fewer moving parts means less downtime

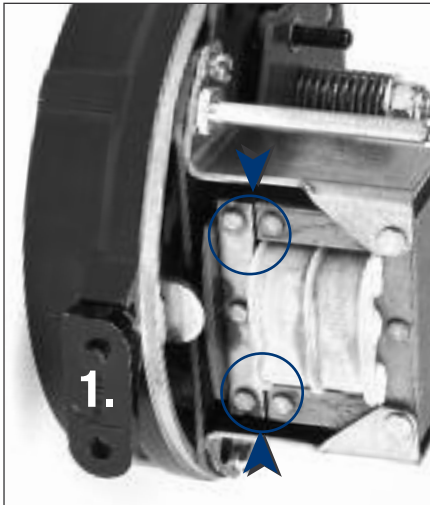

Figure 1:

When the motor is 'off', the driven load can be moved without energizing the motor by rotating the manual release lever 90° clockwise which removes the retarding torque from the motor shaft.

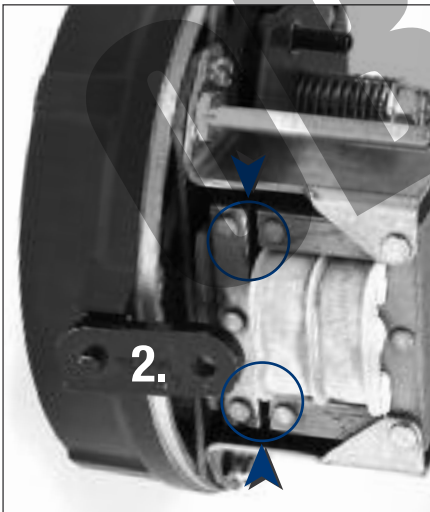

Figure 2:

The lever returns to the normal "set" position when the brake is re-energized.

Spring Applied — Power-Off Operation

Warner Electric spring applied motor brakes are designed to decelerate or park inertial loads when the voltage is turned off, either intentionally or accidentally, as in the case of power failure. The friction disc with the hub is coupled to the motor shaft to be braked but is capable of moving axially. When power is off, a spring force clamps the friction disc between a pressure plate and a stationary plate, hence retarding motion. When an AC voltage is applied, the solenoid creates a Direct Acting magnetic force which releases the friction disk without the use of a linkage. This allows the hub and motor shaft to turn freely.

Features

- External manual release lever
- Totally enclosed construction
- Torque adjustable from full rated torque down to 50%
- Single phase AC coils provide fast engagement and release times and easy wiring.

Mounting

Two styles are available: the single C-Face brake and the double C-Face brake. The single C-Face mounts on the non-driven end of a motor. The C-Face brake is interchangeable with existing brakes and can be used on motors that are modified to accept a brake. The double C-Face brake can be used as a coupler between standard C-Face motors and C-Face gear reducers. All motor brakes are interchangeable with competitive motor brakes.

F Series UNIBRAKES

C-Face AC Rear-Mounted Brakes with NEMA 2 Housing Aluminum Head-Steel Cover

56,000 NEMA 2; 56,100 NEMA 2; 56,300 NEMA 1

Warner Electric Single C-Face Power-Off Brakes are designed to decelerate or hold inertia loads when the power is turned off. The single C-Face mounts on the non-driven end of a motor. Brakes are available from 3 ft. lb. to 15 ft. lb.

Features:

- External manual release lever
- Totally enclosed construction
- Torque adjustable from full-rated torque down to 50%
- Single-phase AC coils to provide fast release times and easy wiring
- Single C-Face



Brake Part Numbers

Technical Data

Coil Voltage	3 ft. lb. Brakes (1 Disc)	6 ft. lb. Brakes (1 Disc)	10 ft. lb. Brakes (2 Discs)	15 ft. lb. Brakes (3 Discs)	Current Holding Amps	Current Inrush Amps
5/8 Bore Hub						
115/230, 60 HZ	F51A0321-W	F51A0621-W	F52A0721-W	F53A0821-W	.50/.25	3.66/1.83
230/460, 60 HZ	F51A0324-W	F51A0624-W	F52A0724-W	F53A0824-W	.28/.14	1.94/.97
287/575, 60 HZ	F51A0325-W	F51A0625-W	F52A0725-W	F53A0825-W	.22/.11	1.54/.77
115/230, 50 HZ	F51A0328-W	F51A0628-W	F52A0728-W	F53A0828-W	.45/.22	3.27/1.64
230/460, 50 HZ	F51A0329-W	F51A0629-W	F52A0729-W	F53A0829-W	.24/.12	1.76/.88
3/4 Bore Hub						
115/230, 60 HZ	F51B0321-W	F51B0621-W	F52B0721-W	F53B0821-W	.50/.25	3.66/1.83
230/460, 60 HZ	F51B0324-W	F51B0624-W	F52B0724-W	F53B0824-W	.28/.14	1.94/.97
287/575, 60 HZ	F51B0325-W	F51B0625-W	F52B0725-W	F53B0825-W	.22/.11	1.54/.77
115/230, 50 HZ	F51B0328-W	F51B0628-W	F52B0728-W	F53B0828-W	.45/.22	3.27/1.64
230/460, 50 HZ	F51B0329-W	F51B0629-W	F52B0729-W	F53B0829-W	.24/.12	1.76/.88
7/8 Bore Hub						
115/230, 60 HZ	F51C0321-W	F51C0621-W	F52C0721-W	F53C0821-W	.50/.25	3.66/1.83
230/460, 60 HZ	F51C0324-W	F51C0624-W	F52C0724-W	F53C0824-W	.28/.14	1.94/.97
287/575, 60 HZ	F51C0325-W	F51C0625-W	F52C0725-W	F53C0825-W	.22/.11	1.54/.77
115/230, 50 HZ	F51C0328-W	F51C0628-W	F52C0728-W	F53C0828-W	.45/.22	3.27/1.64
230/460, 50 HZ	F51C0329-W	F51C0629-W	F52C0729-W	F53C0829-W	.24/.12	1.76/.88

C-Face AC Rear-Mounted Brakes with NEMA 2 Housing Aluminum Head-Steel Cover

56,000 NEMA 2

Stearns®

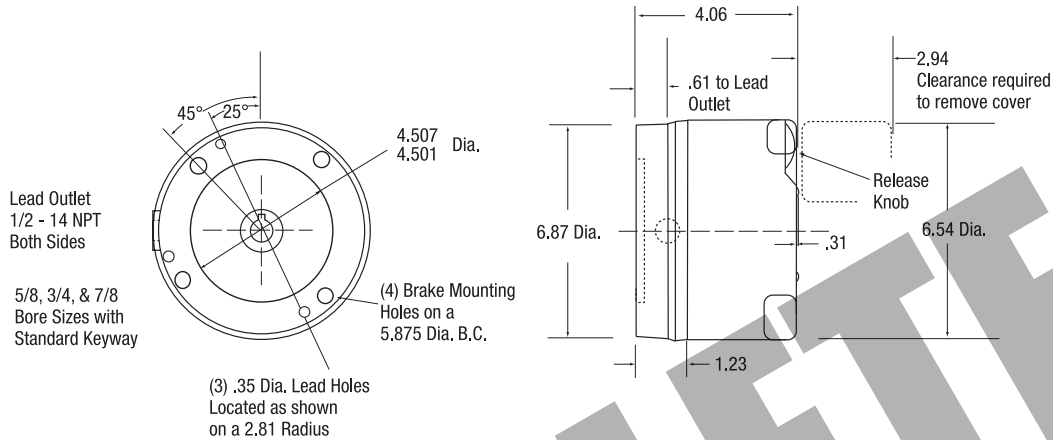

Warner UNIBRAKE

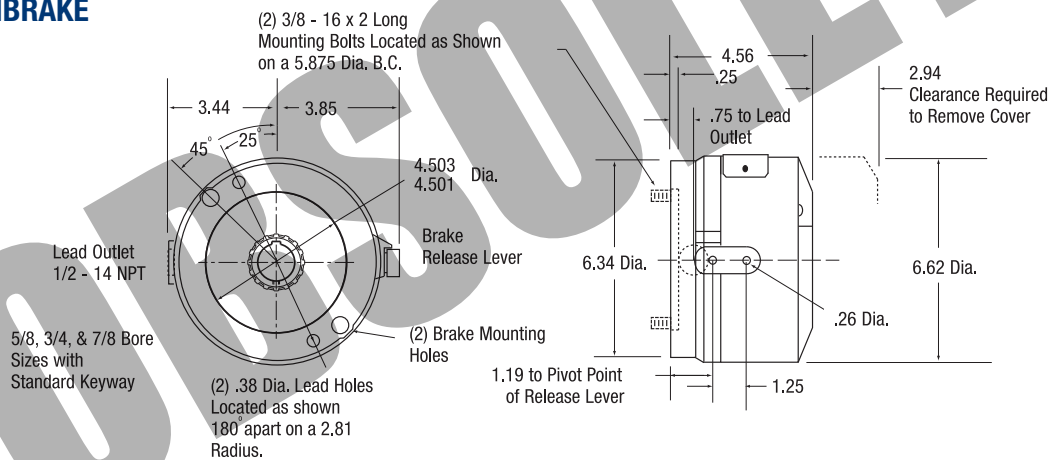

UNIBRAKE Interchange

Stearns® Part Number	Warner Electric Replacement	Stearns® Part Number	Warner Electric Replacement	Stearns® Part Number	Warner Electric Replacement
1-056-011-00-BNF	F51A0325-W	1-056-021-00-CNF	F51B0625-W	1-056-031-00-DNF	F52C0725-W
1-056-011-00-BOF	F51A0328-W	1-056-021-00-COF	F51B0628-W	1-056-031-00-DOF	F52C0728-W
1-056-011-00-BPF	F51A0321-W	1-056-021-00-CPF	F51B0621-W	1-056-031-00-DPF	F52C0721-W
1-056-011-00-BQF	F51A0324-W	1-056-021-00-CQF	F51B0624-W	1-056-031-00-DQF	F52C0724-W
1-056-011-00-CNF	F51B0325-W	1-056-021-00-DNF	F51C0625-W	1-056-041-00-BNF	F53A0825-W
1-056-011-00-COF	F51B0328-W	1-056-021-00-DOF	F51C0628-W	1-056-041-00-BOF	F53A0828-W
1-056-011-00-CPF	F51B0321-W	1-056-021-00-DPF	F51C0621-W	1-056-041-00-BPF	F53A0821-W
1-056-011-00-CQF	F51B0324-W	1-056-021-00-DQF	F51C0624-W	1-056-041-00-BQF	F53A0824-W
1-056-011-00-DNF	F51C0325-W	1-056-031-00-BNF	F52A0725-W	1-056-041-00-CNF	F53B0825-W
1-056-011-00-DOF	F51C0328-W	1-056-031-00-BOF	F52A0728-W	1-056-041-00-COF	F53B0828-W
1-056-011-00-DPF	F51C0321-W	1-056-031-00-BPF	F52A0721-W	1-056-041-00-CPF	F53B0821-W
1-056-011-00-DQF	F51C0324-W	1-056-031-00-BQF	F52A0724-W	1-056-041-00-CQF	F53B0824-W
1-056-021-00-BNF	F51A0625-W	1-056-031-00-CNF	F52B0725-W	1-056-041-00-DNF	F53C0825-W
1-056-021-00-BOF	F51A0628-W	1-056-031-00-COF	F52B0728-W	1-056-041-00-DOF	F53C0828-W
1-056-021-00-BPF	F51A0621-W	1-056-031-00-CPF	F52B0721-W	1-056-041-00-DPF	F53C0821-W
1-056-021-00-BQF	F51A0624-W	1-056-031-00-CQF	F52B0724-W	1-056-041-00-DQF	F53C0824-W

F Series UNIBRAKES

C-Face AC Rear-Mounted Brakes with NEMA 2 Housing Aluminum Head-Steel Cover

56,100 NEMA 2

Stearns®

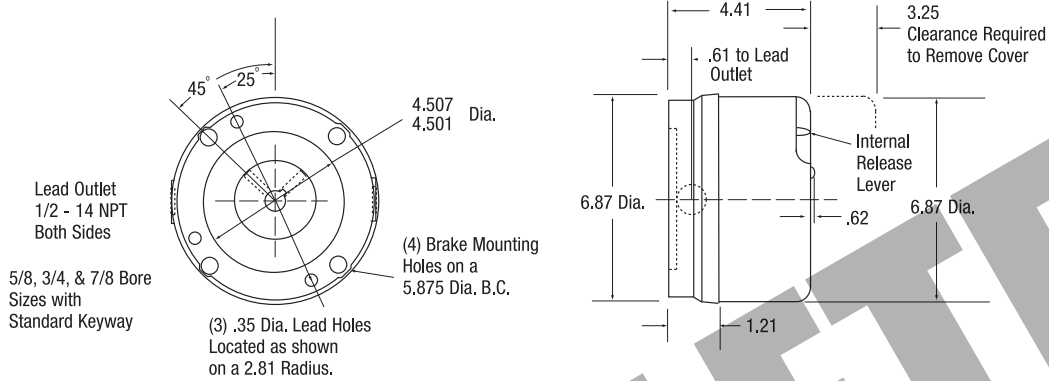

Warner UNIBRAKE

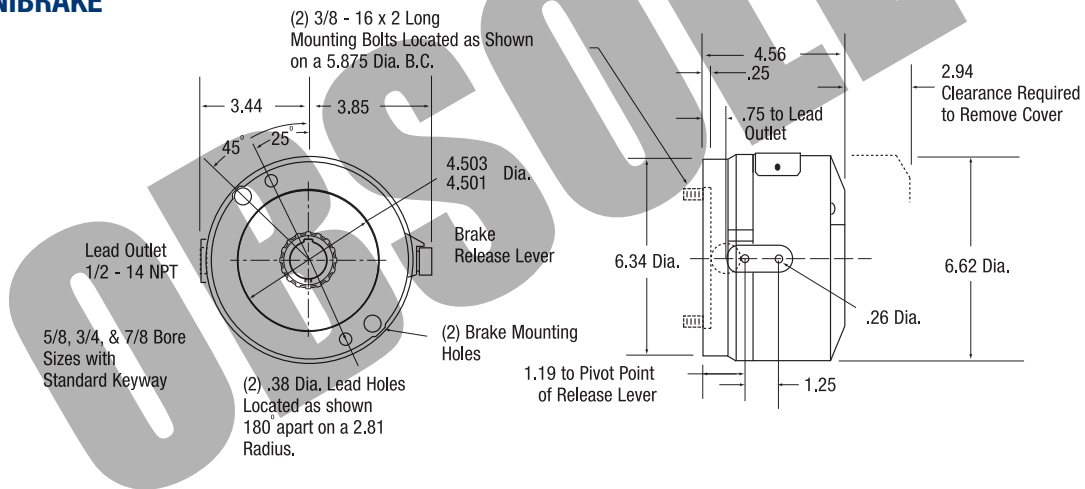

UNIBRAKE Interchange

Stearns® Part Number	Warner Electric Replacement	Stearns® Part Number	Warner Electric Replacement	Stearns® Part Number	Warner Electric Replacement
1-056-111-00-BNF	F51A0325-W	1-056-121-00-CNF	F51B0625-W	1-056-131-00-DNF	F52C0725-W
1-056-111-00-BOF	F51A0328-W	1-056-121-00-COF	F51B0628-W	1-056-131-00-DOF	F52C0728-W
1-056-111-00-BPF	F51A0321-W	1-056-121-00-CPF	F51B0621-W	1-056-131-00-DPF	F52C0721-W
1-056-111-00-BQF	F51A0324-W	1-056-121-00-CQF	F51B0624-W	1-056-131-00-DQF	F52C0724-W
1-056-111-00-CNF	F51B0325-W	1-056-121-00-DNF	F51C0625-W	1-056-141-00-BNF	F53A0825-W
1-056-111-00-COF	F51B0328-W	1-056-121-00-DOF	F51C0628-W	1-056-141-00-BOF	F53A0828-W
1-056-111-00-CPF	F51B0321-W	1-056-121-00-DPF	F51C0621-W	1-056-141-00-BPF	F53A0821-W
1-056-111-00-CQF	F51B0324-W	1-056-121-00-DQF	F51C0624-W	1-056-141-00-BQF	F53A0824-W
1-056-111-00-DNF	F51C0325-W	1-056-131-00-BNF	F52A0725-W	1-056-141-00-CNF	F53B0825-W
1-056-111-00-DOF	F51C0328-W	1-056-131-00-BOF	F52A0728-W	1-056-141-00-COF	F53B0828-W
1-056-111-00-DPF	F51C0321-W	1-056-131-00-BPF	F52A0721-W	1-056-141-00-CPF	F53B0821-W
1-056-111-00-DQF	F51C0324-W	1-056-131-00-BQF	F52A0724-W	1-056-141-00-CQF	F53B0824-W
1-056-121-00-BNF	F51A0625-W	1-056-131-00-CNF	F52B0725-W	1-056-141-00-DNF	F53C0825-W
1-056-121-00-BOF	F51A0628-W	1-056-131-00-COF	F52B0728-W	1-056-141-00-DOF	F53C0828-W
1-056-121-00-BPF	F51A0621-W	1-056-131-00-CPF	F52B0721-W	1-056-141-00-DPF	F53C0821-W
1-056-121-00-BQF	F51A0624-W	1-056-131-00-CQF	F52B0724-W	1-056-141-00-DQF	F53C0824-W

C-Face AC Rear-Mounted Brakes with NEMA 1 Housing Aluminum Head-Steel Cover

56,300 NEMA 1

Stearns®

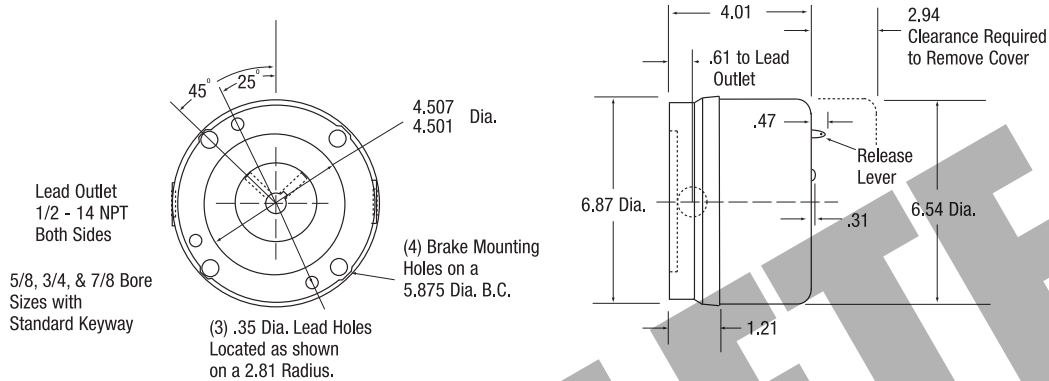

Warner UNIBRAKE

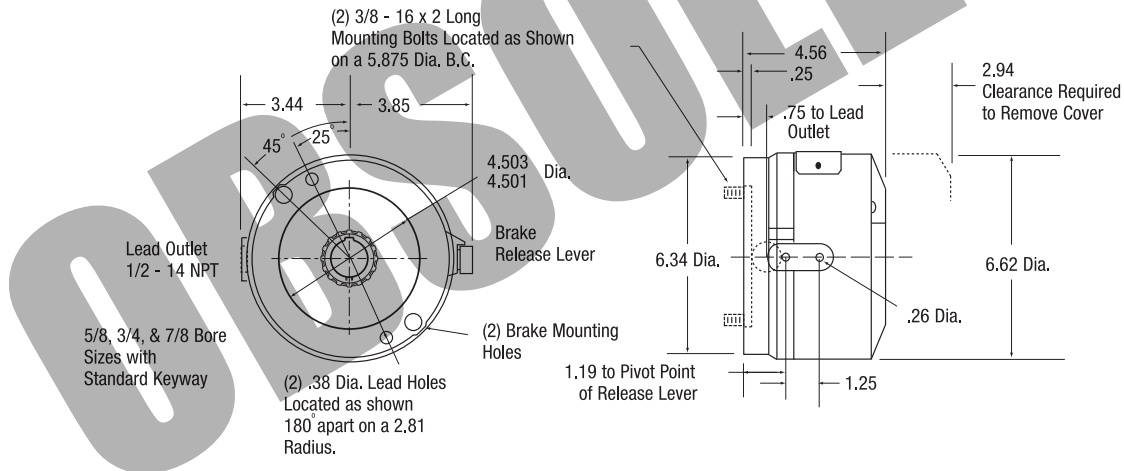

UNIBRAKE Interchange

Stearns® Part Number	Warner Electric Replacement	Stearns® Part Number	Warner Electric Replacement	Stearns® Part Number	Warner Electric Replacement
1-056-311-00-BNF	F51A0325-W	1-056-321-00-CNF	F51B0625-W	1-056-331-00-DNF	F52C0725-W
1-056-311-00-BOF	F51A0328-W	1-056-321-00-COF	F51B0628-W	1-056-331-00-DOF	F52C0728-W
1-056-311-00-BPF	F51A0321-W	1-056-321-00-CPF	F51B0621-W	1-056-331-00-DPF	F52C0721-W
1-056-311-00-BQF	F51A0324-W	1-056-321-00-CQF	F51B0624-W	1-056-331-00-DQF	F52C0724-W
1-056-311-00-CNF	F51B0325-W	1-056-321-00-DNF	F51C0625-W	1-056-341-00-BNF	F53A0825-W
1-056-311-00-COF	F51B0328-W	1-056-321-00-DOF	F51C0628-W	1-056-341-00-BOF	F53A0828-W
1-056-311-00-CPF	F51B0321-W	1-056-321-00-DPF	F51C0621-W	1-056-341-00-BPF	F53A0821-W
1-056-311-00-CQF	F51B0324-W	1-056-321-00-DQF	F51C0624-W	1-056-341-00-BQF	F53A0824-W
1-056-311-00-DNF	F51C0325-W	1-056-331-00-BNF	F52A0725-W	1-056-341-00-CNF	F53B0825-W
1-056-311-00-DOF	F51C0328-W	1-056-331-00-BOF	F52A0728-W	1-056-341-00-COF	F53B0828-W
1-056-311-00-DPF	F51C0321-W	1-056-331-00-BPF	F52A0721-W	1-056-341-00-CPF	F53B0821-W
1-056-311-00-DQF	F51C0324-W	1-056-331-00-BQF	F52A0724-W	1-056-341-00-CQF	F53B0824-W
1-056-321-00-BNF	F51A0625-W	1-056-331-00-CNF	F52B0725-W	1-056-341-00-DNF	F53C0825-W
1-056-321-00-BOF	F51A0628-W	1-056-331-00-COF	F52B0728-W	1-056-341-00-DOF	F53C0828-W
1-056-321-00-BPF	F51A0621-W	1-056-331-00-CPF	F52B0721-W	1-056-341-00-DPF	F53C0821-W
1-056-321-00-BQF	F51A0624-W	1-056-331-00-CQF	F52B0724-W	1-056-341-00-DQF	F53C0824-W

F Series UNIBRAKES

C-Face AC Rear-Mounted Brakes with NEMA 2 Housing Cast Iron Head-Steel Cover

56,400 NEMA 2

Warner Electric Single C-Face Power-Off Brakes are designed to decelerate or hold inertia loads when the power is turned off. The single C-Face mounts on the non-driven end of a motor. Brakes are available from 3 ft. lb. to 15 ft. lb.

Features:

- External manual release lever
- Totally enclosed construction
- Torque adjustable from full-rated torque down to 50%
- Single-phase AC coils to provide fast release times and easy wiring
- Single C-Face



Brake Part Numbers

Technical Data

Coil Voltage	3 ft. lb. Brakes (1 Disc)	6 ft. lb. Brakes (1 Disc)	10 ft. lb. Brakes (2 Discs)	15 ft. lb. Brakes (3 Discs)	Current Holding Amps	Current Inrush Amps
5/8 Bore Hub						
115/230, 60 HZ	F51A7321-W	F51A7621-W	F52A7721-W	F53A7821-W	.50/.25	3.66/1.83
230/460, 60 HZ	F51A7324-W	F51A7624-W	F52A7724-W	F53A7824-W	.28/.14	1.94/.97
287/575, 60 HZ	F51A7325-W	F51A7625-W	F52A7725-W	F53A7825-W	.22/.11	1.54/.77
115/230, 50 HZ	F51A7328-W	F51A7628-W	F52A7728-W	F53A7828-W	.45/.22	3.27/1.64
230/460, 50 HZ	F51A7329-W	F51A7629-W	F52A7729-W	F53A7829-W	.24/.12	1.76/.88
3/4 Bore Hub						
115/230, 60 HZ	F51B7321-W	F51B7621-W	F52B7721-W	F53B7821-W	.50/.25	3.66/1.83
230/460, 60 HZ	F51B7324-W	F51B7624-W	F52B7724-W	F53B7824-W	.28/.14	1.94/.97-W
287/575, 60 HZ	F51B7325-W	F51B7625-W	F52B7725-W	F53B7825-W	.22/.11	1.54/.77
115/230, 50 HZ	F51B7328-W	F51B7628-W	F52B7728-W	F53B7828-W	.45/.22	3.27/1.64
230/460, 50 HZ	F51B7329-W	F51B7629-W	F52B7729-W	F53B7829-W	.24/.12	1.76/.88
7/8 Bore Hub						
115/230, 60 HZ	F51C7321-W	F51C7621-W	F52C7721-W	F53C7821-W	.50/.25	3.66/1.83
230/460, 60 HZ	F51C7324-W	F51C7624-W	F52C7724-W	F53C7824-W	.28/.14	1.94/.97
287/575, 60 HZ	F51C7325-W	F51C7625-W	F52C7725-W	F53C7825-W	.22/.11	1.54/.77
115/230, 50 HZ	F51C7328-W	F51C7628-W	F52C7728-W	F53C7828-W	.45/.22	3.27/1.64
230/460, 50 HZ	F51C7329-W	F51C7629-W	F52C7729-W	F53C7829-W	.24/.12	1.76/.88

C-Face AC Rear-Mounted Brakes with NEMA 2 Housing Cast Iron Head-Steel Cover

56,400 NEMA 2

Stearns®

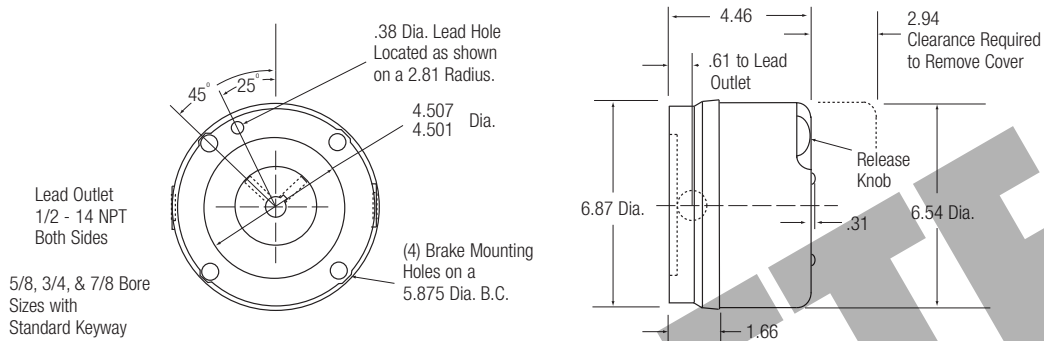

Warner UNIBRAKE

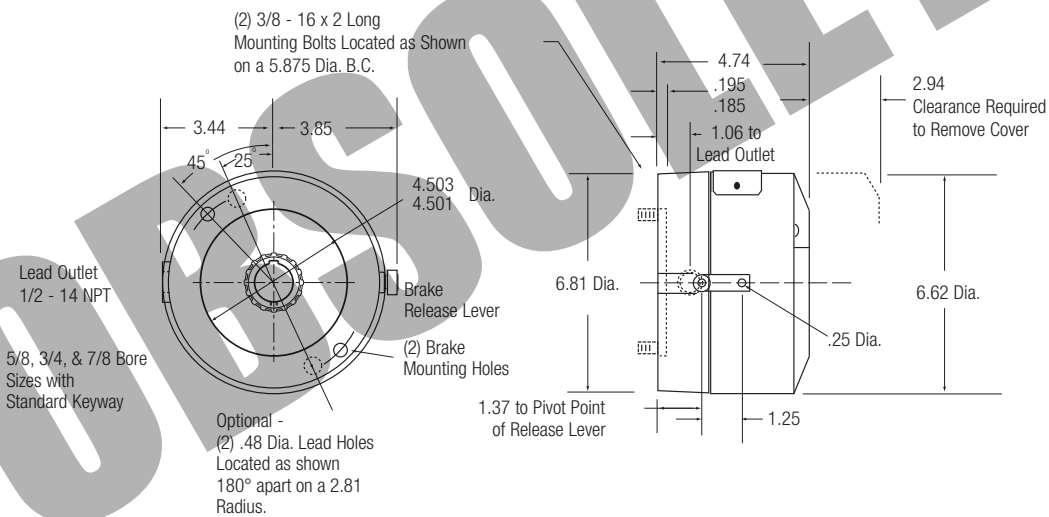

UNIBRAKE Interchange

Stearns® Part Number	Warner Electric Replacement	Stearns® Part Number	Warner Electric Replacement	Stearns® Part Number	Warner Electric Replacement
1-056-411-00-BNF	F51A7325-W	1-056-421-00-CNF	F51B7625-W	1-056-431-00-DNF	F52C7725-W
1-056-411-00-BOF	F51A7328-W	1-056-421-00-COF	F51B7628-W	1-056-431-00-DOF	F52C7728-W
1-056-411-00-BPF	F51A7321-W	1-056-421-00-CPF	F51B7621-W	1-056-431-00-DPF	F52C7721-W
1-056-411-00-BQF	F51A7324-W	1-056-421-00-CQF	F51B7624-W	1-056-431-00-DQF	F52C7724-W
1-056-411-00-CNF	F51B7325-W	1-056-421-00-DNF	F51C7625-W	1-056-441-00-BNF	F53A7825-W
1-056-411-00-COF	F51B7328-W	1-056-421-00-DOF	F51C7628-W	1-056-441-00-BOF	F53A7828-W
1-056-411-00-CPF	F51B7321-W	1-056-421-00-DPF	F51C7621-W	1-056-441-00-BPF	F53A7821-W
1-056-411-00-CQF	F51B7324-W	1-056-421-00-DQF	F51C7624-W	1-056-441-00-BQF	F53A7824-W
1-056-411-00-DNF	F51C7325-W	1-056-431-00-BNF	F52A7725-W	1-056-441-00-CNF	F53B7825-W
1-056-411-00-DOF	F51C7328-W	1-056-431-00-BOF	F52A7728-W	1-056-441-00-COF	F53B7828-W
1-056-411-00-DPF	F51C7321-W	1-056-431-00-BPF	F52A7721-W	1-056-441-00-CPF	F53B7821-W
1-056-411-00-DQF	F51C7324-W	1-056-431-00-BQF	F52A7724-W	1-056-441-00-CQF	F53B7824-W
1-056-421-00-BNF	F51A7625-W	1-056-431-00-CNF	F52B7725-W	1-056-441-00-DNF	F53C7825-W
1-056-421-00-BOF	F51A7628-W	1-056-431-00-COF	F52B7728-W	1-056-441-00-DOF	F53C7828-W
1-056-421-00-BPF	F51A7621-W	1-056-431-00-CPF	F52B7721-W	1-056-441-00-DPF	F53C7821-W
1-056-421-00-BQF	F51A7624-W	1-056-431-00-CQF	F52B7724-W	1-056-441-00-DQF	F53C7824-W

F Series UNIBRAKES

C-Face AC Rear-Mounted Brakes with NEMA 2 Housing Cast Iron Head and Cover

56,200 NEMA 2

Warner Electric Single C-Face Power-Off Brake is also available with cast iron housing for applications involving corrosive environments. Brakes are available from 3 ft. lb. to 15 ft. lb.

Features:

- External manual release lever
- Totally enclosed construction
- Torque adjustable from full-rated torque down to 50%
- Single-phase AC coils to provide fast release times and easy wiring
- Single C-Face



Brake Part Numbers

Technical Data

Coil Voltage	3 ft. lb. Brakes (1 Disc)	6 ft. lb. Brakes (1 Disc)	10 ft. lb. Brakes (2 Discs)	15 ft. lb. Brakes (3 Discs)	Current Holding Amps	Current Inrush Amps
5/8 Bore Hub						
115/230, 60 HZ	F51A8311-W	F51A8611-W	F52A8711-W	F53A8811-W	.50/.25	3.66/1.83
230/460, 60 HZ	F51A8314-W	F51A8614-W	F52A8714-W	F53A8814-W	.28/.14	1.94/.97
287/575, 60 HZ	F51A8315-W	F51A8615-W	F52A8715-W	F53A8815-W	.22/.11	1.54/.77
115/230, 50 HZ	F51A8318-W	F51A8618-W	F52A8718-W	F53A8818-W	.45/.22	3.27/1.64
230/460, 50 HZ	F51A8319-W	F51A8619-W	F52A8719-W	F53A8819-W	.24/.12	1.76/.88
3/4 Bore Hub						
115/230, 60 HZ	F51B8311-W	F51B8611-W	F52B8711-W	F53B8811-W	.50/.25	3.66/1.83
230/460, 60 HZ	F51B8314-W	F51B8614-W	F52B8714-W	F53B8814-W	.28/.14	1.94/.97
287/575, 60 HZ	F51B8315-W	F51B8615-W	F52B8715-W	F53B8815-W	.22/.11	1.54/.77
115/230, 50 HZ	F51B8318-W	F51B8618-W	F52B8718-W	F53B8818-W	.45/.22	3.27/1.64
230/460, 50 HZ	F51B8319-W	F51B8619-W	F52B8719-W	F53B8819-W	.24/.12	1.76/.88
7/8 Bore Hub						
115/230, 60 HZ	F51C8311-W	F51C8611-W	F52C8711-W	F53C8811-W	.50/.25	3.66/1.83
230/460, 60 HZ	F51C8314-W	F51C8614-W	F52C8714-W	F53C8814-W	.28/.14	1.94/.97
287/575, 60 HZ	F51C8315-W	F51C8615-W	F52C8715-W	F53C8815-W	.22/.11	1.54/.77
115/230, 50 HZ	F51C8318-W	F51C8618-W	F52C8718-W	F53C8818-W	.45/.22	3.27/1.64
230/460, 50 HZ	F51C8319-W	F51C8619-W	F52C8719-W	F53C8819-W	.24/.12	1.76/.88

C-Face AC Rear-Mounted Brakes with NEMA 2 Housing Cast Iron Head and Cover

56,200 NEMA 2

Stearns®

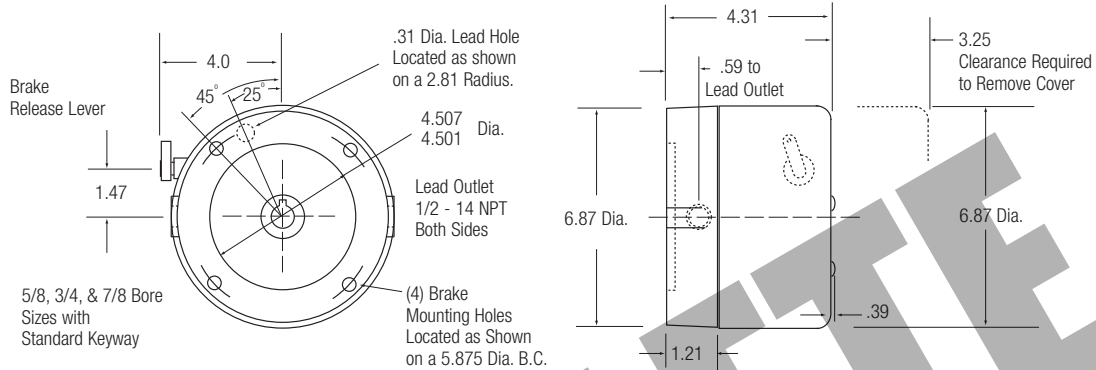

Warner UNIBRAKE

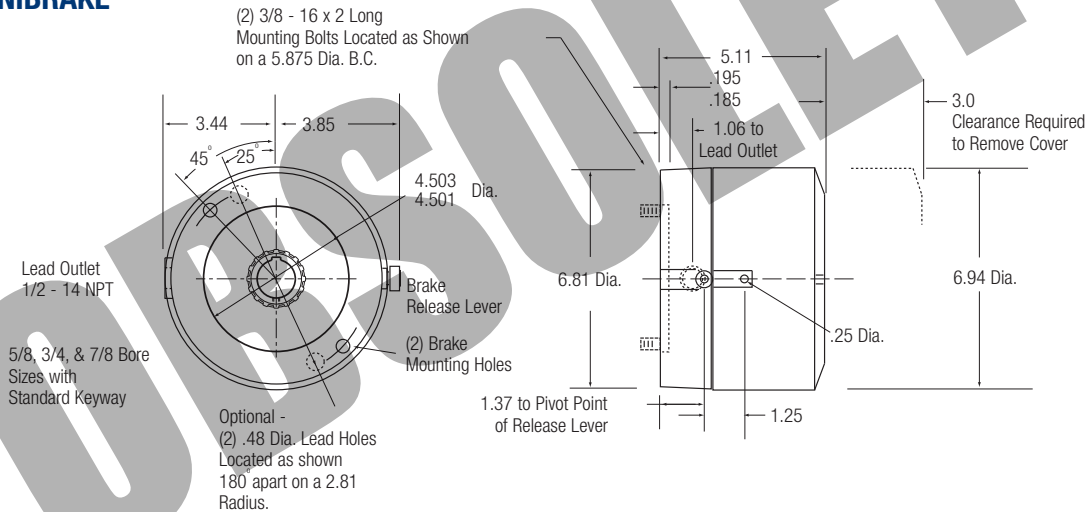

UNIBRAKE Interchange

Stearns® Part Number	Warner Electric Replacement	Stearns® Part Number	Warner Electric Replacement	Stearns® Part Number	Warner Electric Replacement
1-056-211-00-BNF	F51A8315-W	1-056-221-00-CNF	F51B8615-W	1-056-231-00-DNF	F52C8715-W
1-056-211-00-BOF	F51A8318-W	1-056-221-00-COF	F51B8618-W	1-056-231-00-DOF	F52C8718-W
1-056-211-00-BPF	F51A8311-W	1-056-221-00-CPF	F51B8611-W	1-056-231-00-DPF	F52C8711-W
1-056-211-00-BQF	F51A8314-W	1-056-221-00-CQF	F51B8614-W	1-056-231-00-DQF	F52C8714-W
1-056-211-00-CNF	F51B8315-W	1-056-221-00-DNF	F51C8615-W	1-056-241-00-BNF	F53A8815-W
1-056-211-00-COF	F51B8318-W	1-056-221-00-DOF	F51C8618-W	1-056-241-00-BOF	F53A8818-W
1-056-211-00-CPF	F51B8311-W	1-056-221-00-DPF	F51C8611-W	1-056-241-00-BPF	F53A8811-W
1-056-211-00-CQF	F51B8314-W	1-056-221-00-DQF	F51C8614-W	1-056-241-00-BQF	F53A8814-W
1-056-211-00-DNF	F51C8315-W	1-056-231-00-BNF	F52A8715-W	1-056-241-00-CNF	F53B8815-W
1-056-211-00-DOF	F51C8318-W	1-056-231-00-BOF	F52A8718-W	1-056-241-00-COF	F53B8818-W
1-056-211-00-DPF	F51C8311-W	1-056-231-00-BPF	F52A8711-W	1-056-241-00-CPF	F53B8811-W
1-056-211-00-DQF	F51C8314-W	1-056-231-00-BQF	F52A8714-W	1-056-241-00-CQF	F53B8814-W
1-056-221-00-BNF	F51A8615-W	1-056-231-00-CNF	F52B8715-W	1-056-241-00-DNF	F53C8815-W
1-056-221-00-BOF	F51A8618-W	1-056-231-00-COF	F52B8718-W	1-056-241-00-DOF	F53C8818-W
1-056-221-00-BPF	F51A8611-W	1-056-231-00-CPF	F52B8711-W	1-056-241-00-DPF	F53C8811-W
1-056-221-00-BQF	F51A8614-W	1-056-231-00-CQF	F52B8714-W	1-056-241-00-DQF	F53C8814-W

F Series UNIBRAKES

C-Face AC Rear-Mounted Brakes with NEMA 4 Housing Cast Iron Head and Cover

56,200 NEMA 4

Warner Electric Single C-Face Power-Off Brake is also available with cast iron housing for applications involving corrosive environments. The heavy-duty housing also includes o-ring seals to create a dust-tight brake. Brakes are available from 3 ft. lb. to 15 ft. lb.

Features:

- External manual release lever
- Totally enclosed construction
- Torque adjustable from full-rated torque down to 50%
- Single-phase AC coils to provide fast release times and easy wiring
- Single C-Face



Brake Part Numbers

Technical Data

Coil Voltage	3 ft. lb. Brakes (1 Disc)	6 ft. lb. Brakes (1 Disc)	10 ft. lb. Brakes (2 Discs)	15 ft. lb. Brakes (3 Discs)	Current Holding Amps	Current Inrush Amps
5/8 Bore Hub						
115/230, 60 HZ	F51A1311-W	F51A1611-W	F52A1711-W	F53A1811-W	.50/.25	3.66/1.83
230/460, 60 HZ	F51A1314-W	F51A1614-W	F52A1714-W	F53A1814-W	.28/.14	1.94/.97
287/575, 60 HZ	F51A1315-W	F51A1615-W	F52A1715-W	F53A1815-W	.22/.11	1.54/.77
115/230, 50 HZ	F51A1318-W	F51A1618-W	F52A1718-W	F53A1818-W	.45/.22	3.27/1.64
230/460, 50 HZ	F51A1319-W	F51A1619-W	F52A1719-W	F53A1819-W	.24/.12	1.76/.88
3/4 Bore Hub						
115/230, 60 HZ	F51B1311-W	F51B1611-W	F52B1711-W	F53B1811-W	.50/.25	3.66/1.83
230/460, 60 HZ	F51B1314-W	F51B1614-W	F52B1714-W	F53B1814-W	.28/.14	1.94/.97
287/575, 60 HZ	F51B1315-W	F51B1615-W	F52B1715-W	F53B1815-W	.22/.11	1.54/.77
115/230, 50 HZ	F51B1318-W	F51B1618-W	F52B1718-W	F53B1818-W	.45/.22	3.27/1.64
230/460, 50 HZ	F51B1319-W	F51B1619-W	F52B1719-W	F53B1819-W	.24/.12	1.76/.88
7/8 Bore Hub						
115/230, 60 HZ	F51C1311-W	F51C1611-W	F52C1711-W	F53C1811-W	.50/.25	3.66/1.83
230/460, 60 HZ	F51C1314-W	F51C1614-W	F52C1714-W	F53C1814-W	.28/.14	1.94/.97
287/575, 60 HZ	F51C1315-W	F51C1615-W	F52C1715-W	F53C1815-W	.22/.11	1.54/.77
115/230, 50 HZ	F51C1318-W	F51C1618-W	F52C1718-W	F53C1818-W	.45/.22	3.27/1.64
230/460, 50 HZ	F51C1319-W	F51C1619-W	F52C1719-W	F53C1819-W	.24/.12	1.76/.88

C-Face AC Rear-Mounted Brakes with NEMA 4 Housing Cast Iron Head and Cover

56,200 NEMA 4

Stearns®

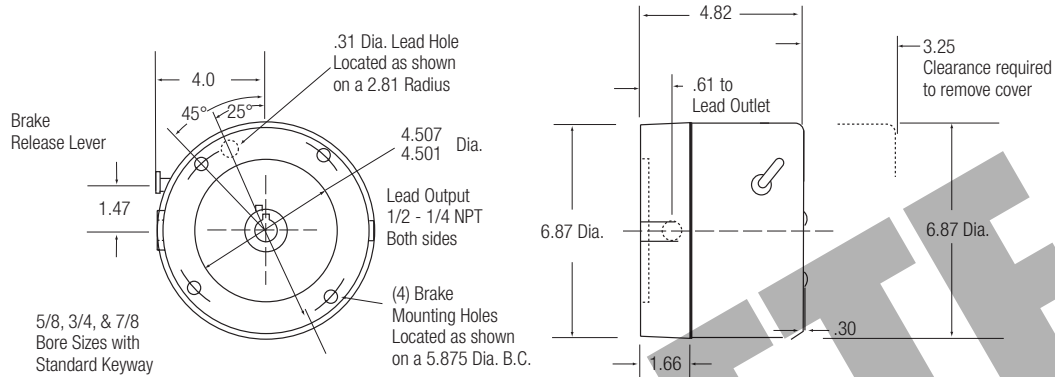

Warner UNIBRAKE

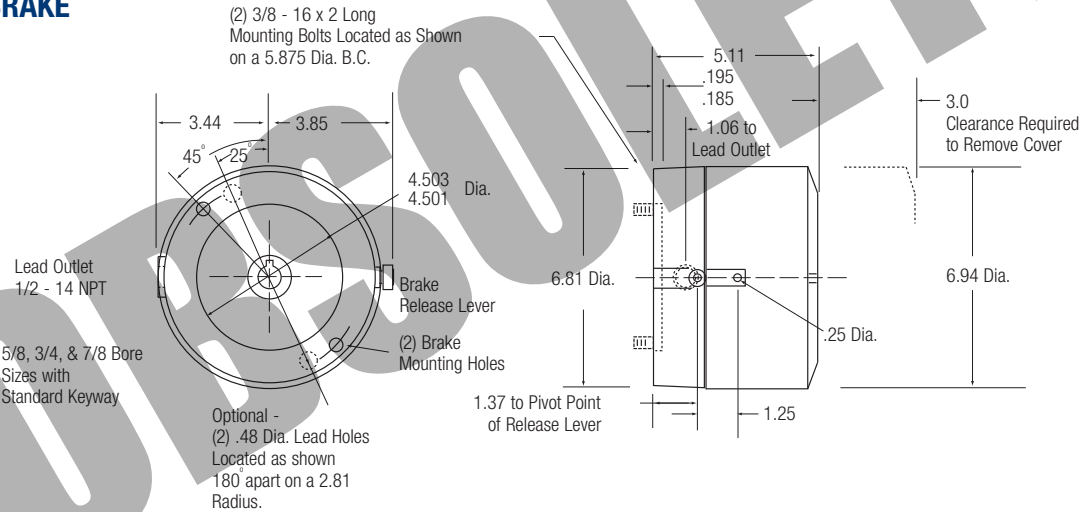

UNIBRAKE Interchange

Stearns® Part Number	Warner Electric Replacement	Stearns® Part Number	Warner Electric Replacement	Stearns® Part Number	Warner Electric Replacement
1-056-212-00-BNF	F51A1315-W	1-056-222-00-CNF	F51B1615-W	1-056-232-00-DNF	F52C1715-W
1-056-212-00-BOF	F51A1318-W	1-056-222-00-COF	F51B1618-W	1-056-232-00-DOF	F52C1718-W
1-056-212-00-BPF	F51A1311-W	1-056-222-00-CPF	F51B1611-W	1-056-232-00-DPF	F52C1711-W
1-056-212-00-BQF	F51A1314-W	1-056-222-00-CQF	F51B1614-W	1-056-232-00-DQF	F52C1714-W
1-056-212-00-CNF	F51B1315-W	1-056-222-00-DNF	F51C1615-W	1-056-242-00-BNF	F53A1815-W
1-056-212-00-COF	F51B1318-W	1-056-222-00-DOF	F51C1618-W	1-056-242-00-BOF	F53A1818-W
1-056-212-00-CPF	F51B1311-W	1-056-222-00-DPF	F51C1611-W	1-056-242-00-BPF	F53A1811-W
1-056-212-00-CQF	F51B1314-W	1-056-222-00-DQF	F51C1614-W	1-056-242-00-BQF	F53A1814-W
1-056-212-00-DNF	F51C1315-W	1-056-232-00-BNF	F52A1715-W	1-056-242-00-CNF	F53B1815-W
1-056-212-00-DOF	F51C1318-W	1-056-232-00-BOF	F52A1718-W	1-056-242-00-COF	F53B1818-W
1-056-212-00-DPF	F51C1311-W	1-056-232-00-BPF	F52A1711-W	1-056-242-00-CPF	F53B1811-W
1-056-212-00-DQF	F51C1314-W	1-056-232-00-BQF	F52A1714-W	1-056-242-00-CQF	F53B1814-W
1-056-222-00-BNF	F51A1615-W	1-056-232-00-CNF	F52B1715-W	1-056-242-00-DNF	F53C1815-W
1-056-222-00-BOF	F51A1618-W	1-056-232-00-COF	F52B1718-W	1-056-242-00-DOF	F53C1818-W
1-056-222-00-BPF	F51A1611-W	1-056-232-00-CPF	F52B1711-W	1-056-242-00-DPF	F53C1811-W
1-056-222-00-BQF	F51A1614-W	1-056-232-00-CQF	F52B1714-W	1-056-242-00-DQF	F53C1814-W

M Series UNIBRAKES

Double C-Face AC Coupler Brakes with NEMA 2 Housing Aluminum Head and Cover

56,700 NEMA 2

The Double C-Face brake is designed for use as a coupler between standard C-Face motors and C-Face gear reducers.

Features:

- External manual release lever
- Totally enclosed construction
- Torque adjustable from full-rated torque down to 50%
- Single-phase AC coils to provide fast release times and easy wiring



Brake Part Numbers

Technical Data

Coil Voltage	3 ft. lb. Brakes (1 Disc)	6 ft. lb. Brakes (1 Disc)	10 ft. lb. Brakes (2 Discs)	Current Holding Amps	Current Inrush Amps
5/8 Bore Shaft and Hub (56C)					
115/230, 60 HZ	M51A0321-W	M51A0621-W	M52A0721-W	.50/.25	3.66/1.83
230/460, 60 HZ	M51A0324-W	M51A0624-W	M52A0724-W	.28/.14	1.94/.97
287/575, 60 HZ	M51A0325-W	M51A0625-W	M52A0725-W	.22/.11	1.54/.77
115/230, 50 HZ	M51A0328-W	M51A0628-W	M52A0728-W	.45/.22	3.27/1.64
230/460, 50 HZ	M51A0329-W	M51A0629-W	M52A0729-W	.24/.12	1.76/.88
7/8 Bore Shaft and Hub (145TC)					
115/230, 60 HZ	M51C0321-W	M51C0621-W	M52C0721-W	.50/.25	3.66/1.83
230/460, 60 HZ	M51C0324-W	M51C0624-W	M52C0724-W	.28/.14	1.94/.97
287/575, 60 HZ	M51C0325-W	M51C0625-W	M52C0725-W	.22/.11	1.54/.77
115/230, 50 HZ	M51C0328-W	M51C0628-W	M52C0728-W	.45/.22	3.27/1.64
230/460, 50 HZ	M51C0329-W	M51C0629-W	M52C0729-W	.24/.12	1.76/.88

Double C-Face AC Coupler Brakes with NEMA 2 Housing Aluminum Head and Cover

56,700 NEMA 2

Stearns®

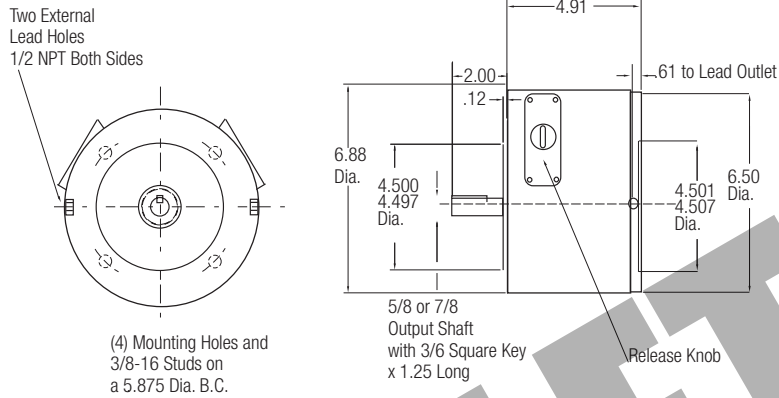

Warner UNIBRAKE

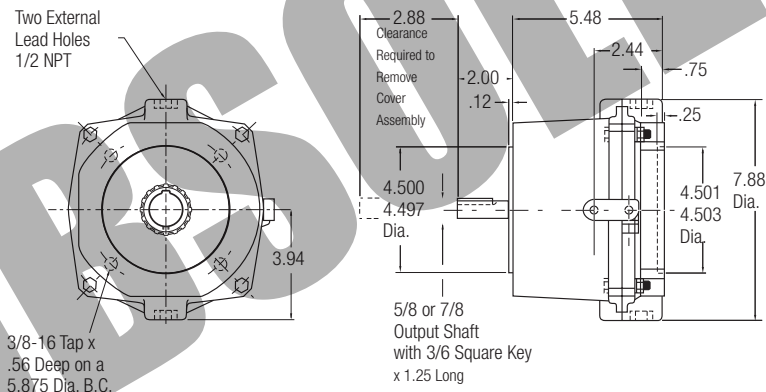

UNIBRAKE Interchange

Stearns® Part Number	Warner Electric Replacement	Stearns® Part Number	Warner Electric Replacement	Stearns® Part Number	Warner Electric Replacement
1-056-711-05-NF	M51A0325-W	1-056-721-05-NF	M51A0625-W	1-056-731-05-NF	M52A0725-W
1-056-711-05-OF	M51A0328-W	1-056-721-05-OF	M51A0628-W	1-056-731-05-OF	M52A0728-W
1-056-711-05-PF	M51A0321-W	1-056-721-05-PF	M51A0621-W	1-056-731-05-PF	M52A0721-W
1-056-711-05-QF	M51A0324-W	1-056-721-05-QF	M51A0624-W	1-056-731-05-QF	M52A0724-W
1-056-711-07-NF	M51C0325-W	1-056-721-07-NF	M51C0625-W	1-056-731-07-NF	M52C0725-W
1-056-711-07-OF	M51C0328-W	1-056-721-07-OF	M51C0628-W	1-056-731-07-OF	M52C0728-W
1-056-711-07-PF	M51C0321-W	1-056-721-07-PF	M51C0621-W	1-056-731-07-PF	M52C0721-W
1-056-711-07-QF	M51C0324-W	1-056-721-07-QF	M51C0624-W	1-056-731-07-QF	M52C0724-W

M Series UNIBRAKES

Double C-Face DC Coupler Brakes with NEMA 2 Housing Aluminum Head and Cover

56,700 NEMA 2

The Double C-Face Brake is designed for use as a coupler between standard C-Face motors and C-Face gear reducers.

Features:

- External manual release lever
- Totally enclosed construction
- Torque adjustable from full-rated torque down to 50%
- DC coils to provide fast release times and easy wiring



Brake Part Numbers

Technical Data

Coil Voltage	3 ft. lb. Brakes (1 Disc)	6 ft. lb. Brakes (2 Discs)	10 ft. lb. Brakes (3 Discs)	Current Holding Amps	Resistance Ohms
5/8 Bore Shaft and Hub (56C)					
24 VDC	M51A032Y-W	M52A062Y-W	M53A072Y-W	.91	26.4
90 VDC	M51A032X-W	M52A062X-W	M53A072X-W	.25	365
7/8 Bore Shaft and Hub (145TC)					
24 VDC	M51C032Y-W	M52C062Y-W	M53C072Y-W	.91	26.4
90 VDC	M51C032X-W	M52C062X-W	M53C072X-W	.25	365

Double C-Face DC Coupler Brakes with NEMA 2 Housing Aluminum Head and Cover

56,700 NEMA 2

Stearns®

Two External
Lead Holes
1/2 NPT Both Sides

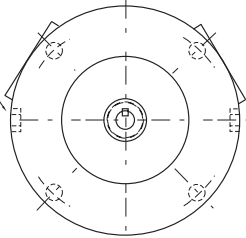

(4) Mounting Holes and
3/8-16 Studs on
a 5.875 Dia. B.C.

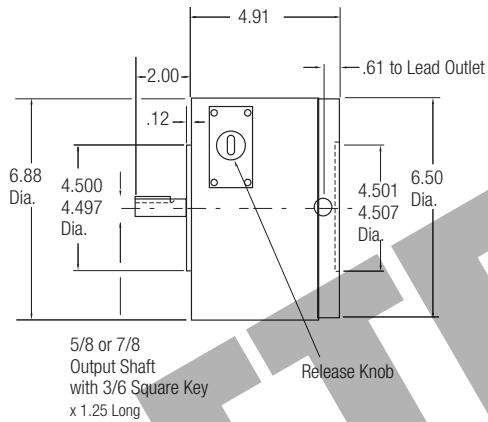

Warner UNIBRAKE

Two External
Lead Holes
1/2 NPT

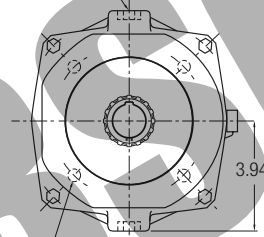

3/8-16 Tap x
.56 Deep on a
5.875 Dia. B.C.

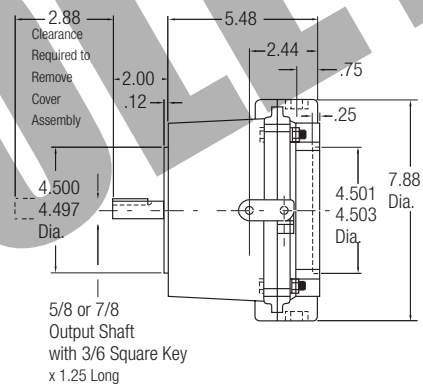

UNIBRAKE Interchange

Stearns® Part Number	Warner Electric Replacement
1-056-711-05-UF	M51A032Y-W
1-056-711-05-XF	M51A032X-W
1-056-711-07-UF	M51C032Y-W
1-056-711-07-XF	M51C032X-W
1-056-721-05-UF	M52A062Y-W
1-056-721-05-XF	M52A062X-W
1-056-721-07-UF	M52C062Y-W
1-056-721-07-XF	M52C062X-W
1-056-731-05-UF	M53A072Y-W
1-056-731-05-XF	M53A072X-W
1-056-731-07-UF	M53C072Y-W
1-056-731-07-XF	M53C072X-W

Ordering Information / Standard NEMA Frame Dimensions.....	187
Mechanical Data / Dynamic Torque	188
Mechanical Data / Rotational Speed.....	190
Mechanical Data / Clutch Field Restraining Devices	191
Electrical Data / Coil Ratings	192
Electrical Data / Installation Procedure	195
Electrical Data / Coil Suppression & Clutch/Brake Overlap	196
Electrical Data / Overexcitation.....	197
Bushing Part Numbers	198
Application Data Form	200

OBSOLETE

Standard NEMA Frame Dimensions Ordering Information

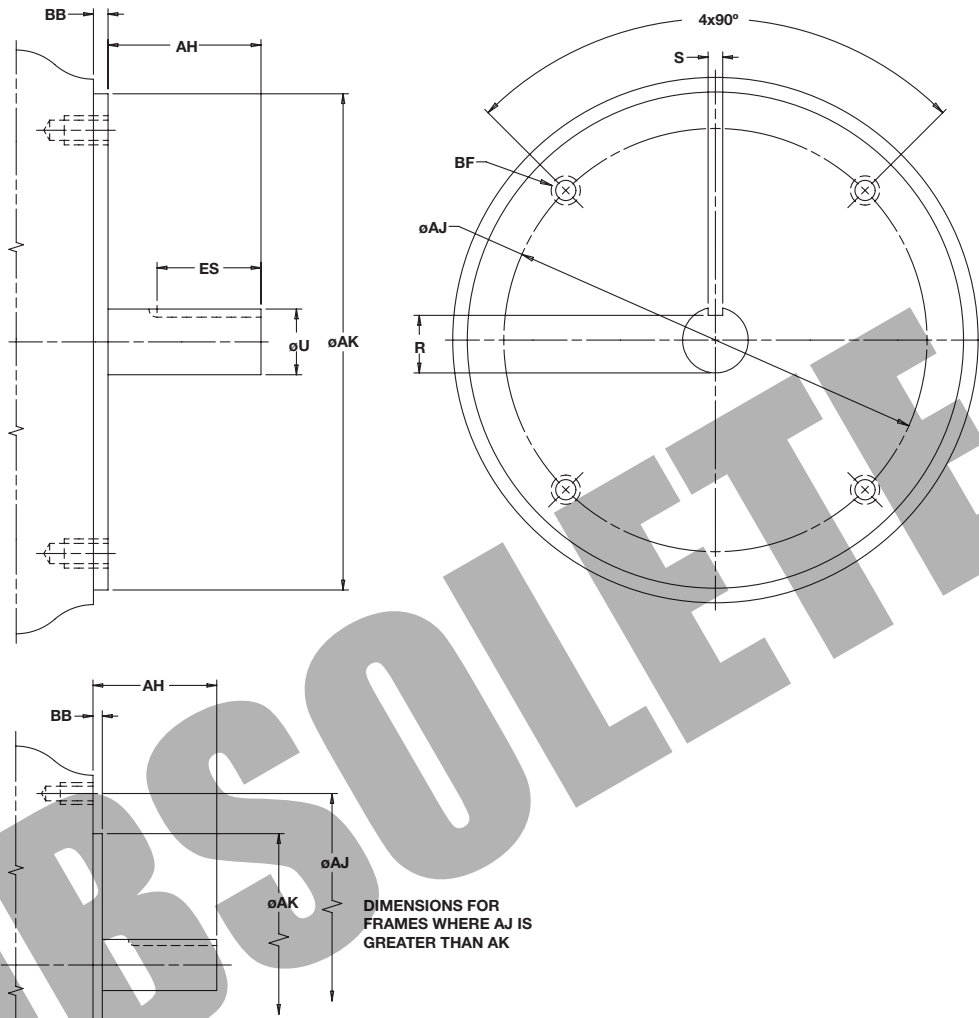

Specifications

Module Size	NEMA Frame Size	AH	AJ	AK	BB	BF	ES	R	S	U
50	56C/48Y	2.06	5.875	4.500	.16 MAX	3/8-16 UNC	1.41 MIN	0.517	0.188	0.625
100	56C/48Y	2.06	5.875	4.500	.16 MAX	3/8-16 UNC	1.41 MIN	0.517	0.188	0.625
180	143TC/145TC	2.12	5.875	4.500	.16 MAX	3/8-16 UNC	1.41 MIN	0.771	0.188	0.875
210	182TC/184TC	2.62	7.250	8.500	.25 MIN	1/2-13 UNC	1.78 MIN	0.986	0.250	1.125
215	213TC/215TC	3.12	7.250	8.500	.25 MIN	1/2-13 UNC	2.41 MIN	1.201	0.312	1.375

Note: Warner Electric Modules are designed to comply with standard NEMA frame dimensions for mounting. Reference to each particular frame size is given in the individual selection tables for each type of Warner Electric module.

Mechanical Data Dynamic Torque

NOTES:

Speed difference means the difference in speed between one friction face and the other at the moment of engagement. The intersection of the top curve and the speed difference is the maximum torque produced by the unit. When both friction faces are engaged and rotating at the same speed, the unit is said to be locked-in and produces the maximum static torque (zero speed difference).

The % lines indicate the percentage of full voltage being used. Example: If 90 volt unit runs at 45 volts, use the 50% line.

Average Torque = Dynamic Torque at $1/2$ operating speed. Example: If operating speed is 1800, use dynamic torque at 900.

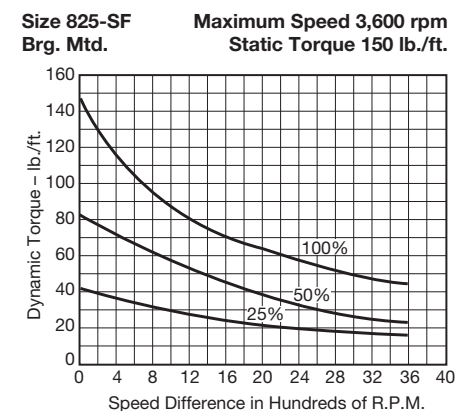
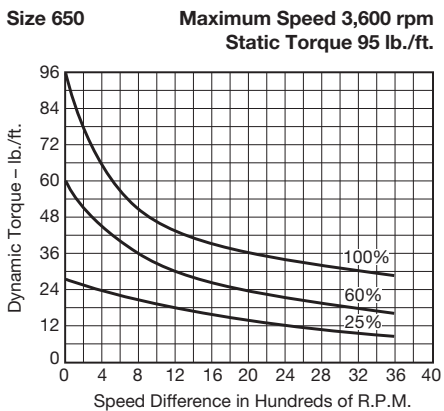
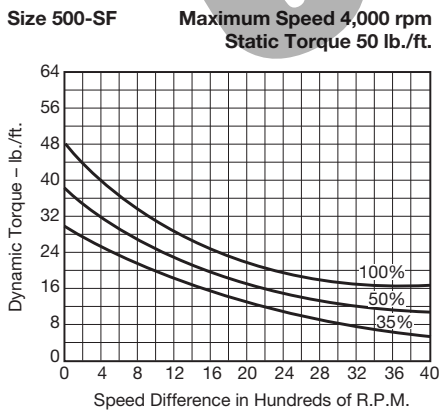
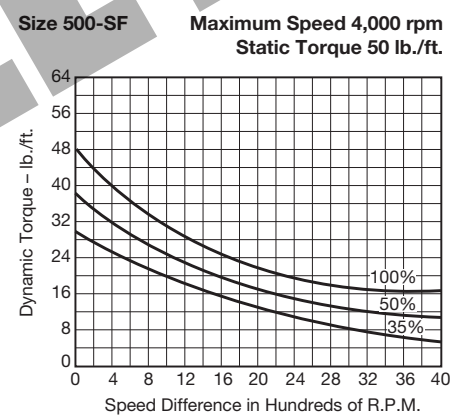
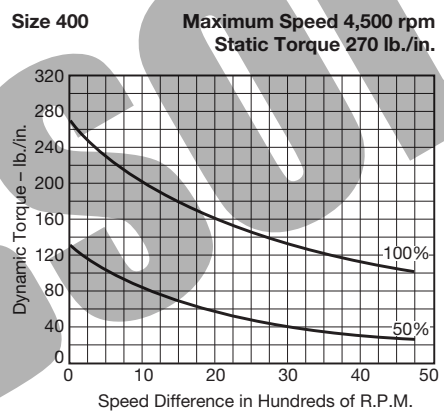
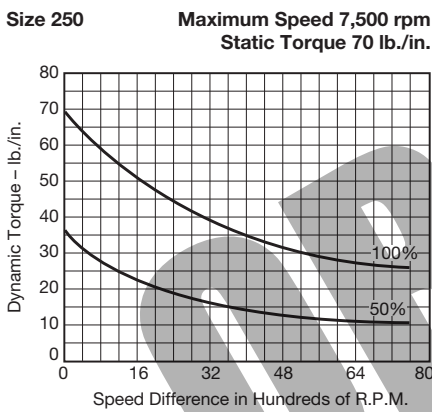
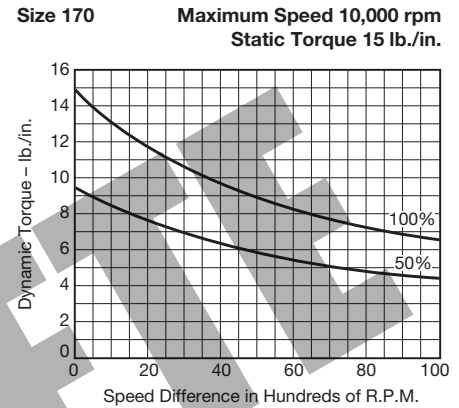
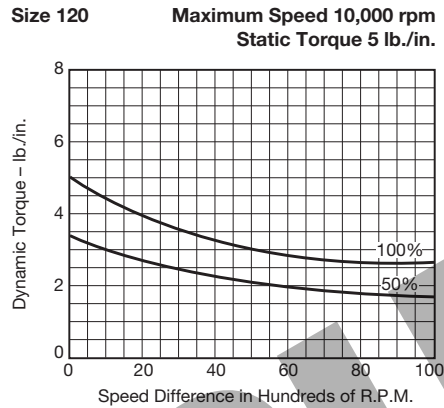

NOTE: Torque values are in inch lbs. for size 400 and smaller, and in ft.lbs. for size 500 and larger.

Mechanical Data Dynamic Torque

Size 825 Maximum Speed 4,000 rpm
Electro-Pack 3,600 rpm
Static Torque 125 lb./ft.

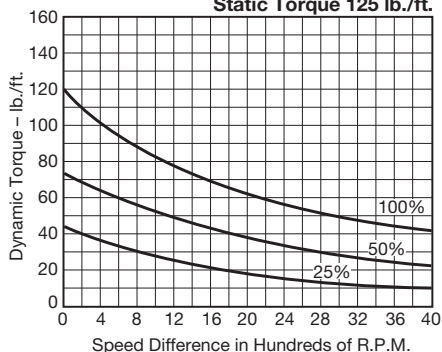

Size 825-MB Maximum Speed 4,000 rpm
Static Torque 80 lb./ft.

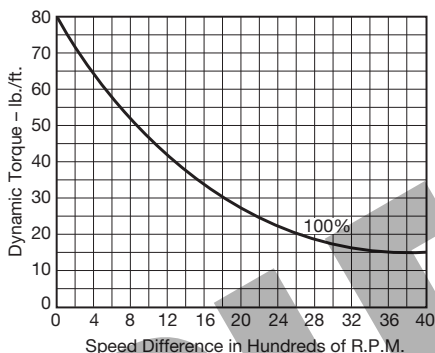

Size 1000 Maximum Speed 3,600 rpm
Electro-Pack 3,000 rpm
Static Torque 240 lb./ft.

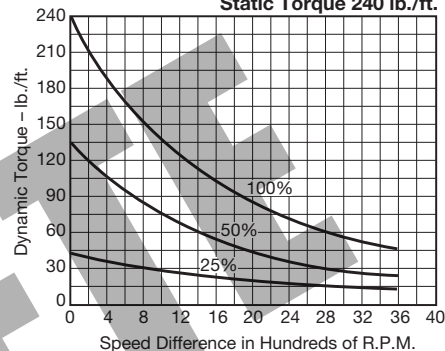

Size 1000-MB Maximum Speed 3,600 rpm
Static Torque 160 lb./ft.

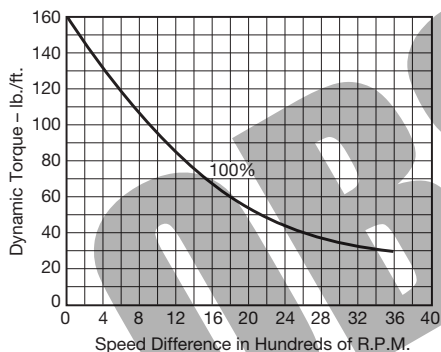

Size 1225 Maximum Speed 3,000 rpm
Static Torque 465 lb./ft.

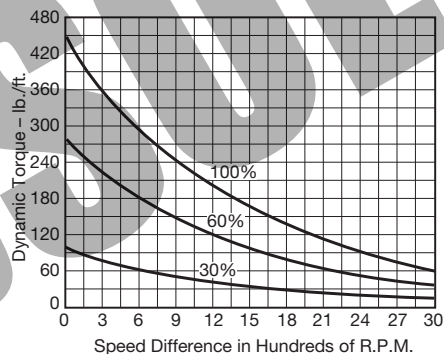

Size 1225-MB Maximum Speed 3,000 rpm
Static Torque 260 lb./ft.

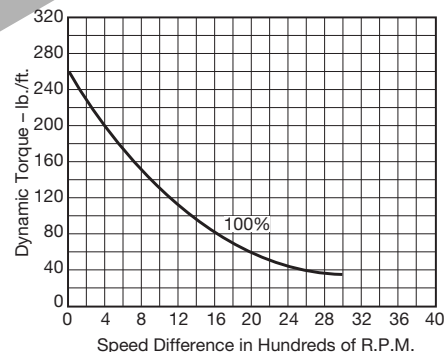

Size 1525 Maximum Speed 2,000 rpm
Electro-Pack 1,800 rpm
Static Torque 700 lb./ft.

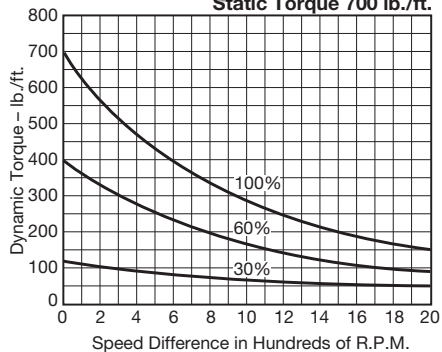

Size 1525-Hi Torque Maximum Speed 2,000 rpm
Static Torque 1,350 lb./ft.

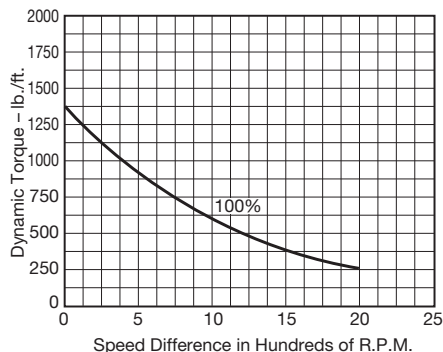

Rotational Speed

Rotational speed of a clutch or brake is an important consideration when selecting a unit for a particular application. Numerous factors must be considered, such as the maximum rated speed of the clutch/brake unit, the dynamic torque required, the heat dissipation needed, the effect of speed on wear rate, and torque stability at very low speeds. Each of these issues are separate, and sometimes interrelated, but always important in selecting the right product for an application.

Maximum RPM Rating

The most important rotational speed consideration is the maximum rated RPM capability of a unit. DO NOT exceed this rating. Exceeding the maximum RPM of a unit may cause personal injury and/or machine damage. Maximum rated speeds are based on the structural integrity of the rotating components and associated shaft and bearing capabilities. If the RPM rating is exceeded, structural failure may occur, or the unit may experience premature bearing failure and/or premature friction material wear out.

Dynamic Torque

When determining the correct size clutch/brake for an application, dynamic torque at the highest slip speed is often the determining factor. As you can see by reviewing the dynamic torque curves for different units as shown starting on page 188, dynamic clutch/brake torque usually decreases with higher speeds. As slip RPM increases, the coefficient of friction of a unit decreases, causing a decrease in dynamic torque availability. Be careful to consider this when selecting the appropriate unit size needed.

Heat Dissipation

Heat dissipation is inversely related to dynamic torque. As RPM increases, the heat dissipation ability of a unit increases. When an armature is rotating, the heat dissipation rate is proportional to the aerodynamic fan effect of the rotating armature. The faster the armature rotates, the greater the heat dissipation. This is illustrated with a typical catalog curve as shown in Figure 1. It's interesting to note that, at zero RPM, the unit still has some heat dissipation capability. This is due to convection and radiation, but is usually not an important consideration.

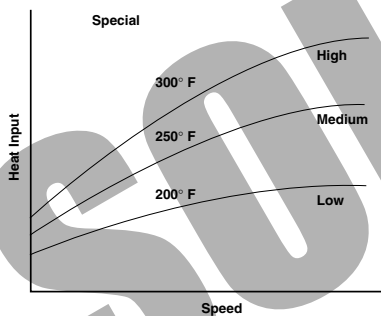

Figure 1: Typical Heat Dissipation Characteristics

Wear Rate

The wear rate of friction surfaces is dependent on the clamping pressure of the mating surfaces as well as the surface velocity between the wearing surfaces. Many variables are involved in predicting wear life, of which RPM is probably the most influential. Typically, the wear rate will increase directly with the rubbing velocity distance. Another way of stating this is the higher the relative engagement speeds of two rotating parts, the longer they are allowed to slip against each other and the faster the wear rate.

Low Speed Operation

The effect of low speed usage should also be considered in applications. Performance of clutch/brake units at less than 100 RPM may be very different than at higher RPM. This is due to "burnish" characteristics of friction surfaces.

Wear In

"Burnish" is the wear in, or mating of two surfaces. When new, these surfaces have manufacturing features which include roughness and waviness. When these surfaces come into initial contact, only the high spots actually meet. See Figure 2. This results in only a small surface area in contact, while the non-contact surface area is "air." The result is low torque. As the mating surfaces continue to engage and slip against each other, the high spots are worn down and more surface area is in contact, thus increasing torque capability. This wear in period, or burnish, typically occurs in the first few hundred cycles of a clutch/brake's life. Faster slip speeds and higher loads mean fewer cycles needed to complete the burnish process. For applications where the speed is less than

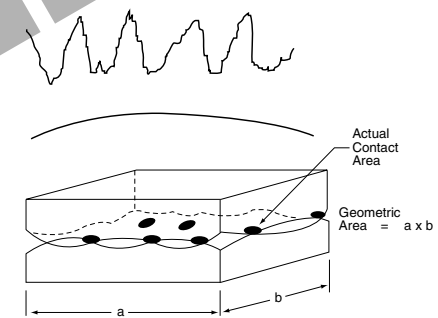

Figure 2: Unburnished Contact Areas

100 RPM, the required application torque should be doubled to compensate for the low speed "burnish" that the unit experiences. A low speed burnish will require many cycles before full torque and stability are achieved. For example, if an application is determined to need 20 ft.lbs. of static torque, an SF-400 clutch could be selected. But, if the application is only 100 RPM or less, then an SF-500 unit should be the choice to compensate for the low RPM usage, as indicated on the selection chart found on page 188.

Careful consideration of rotating speeds will help the selection process of an application. Follow these guidelines and the proper clutch/brake selected will provide troublefree operation.

Mechanical Data Clutch Field Restraining Devices

Many Warner Electric clutch assemblies have a bearing mounted stationery field. By design the bearing maintains its proper position between the field and rotor making it easy for the customer to mount the field-rotor assembly. However, the bearing has a slight drag which tends to make the field rotate if not restrained. And, since the field has lead wires attached, it must be restrained to prevent rotation and pulling of these wires. To counteract this rotational force, the field has a "torque tab" to which the customer must attach an appropriate anti-rotational restraint.

A few hints regarding proper torque tab restraints are in order. First and foremost, it is important to recognize that the force to be overcome is very small and the tab should not be restrained in any manner which will preload the bearing. For example, if the clutch is mounted with the back of the field adjacent to a rigid machine member the customer should not attach a capscrew tightly between the tab and the machine member. This may pull the tab back against the rigid member as shown in Figure 1 and preload the bearing. The recommended methods are illustrated in Figures 2, 3, and 4. The method selected is primarily a matter of customer preference or convenience.

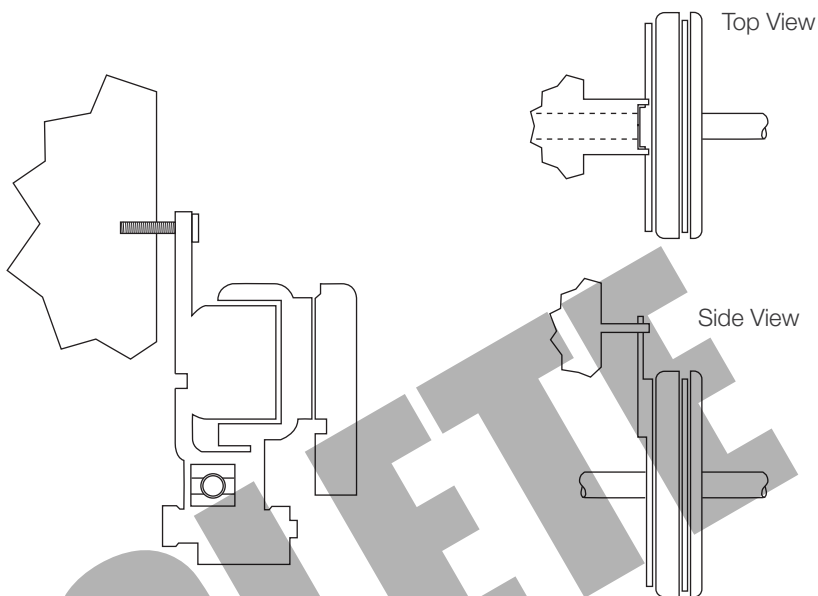

Figure 1:
Rigid member

Figure 2:
Rigid Member with Slot
Straddling Tab
(Preferred)

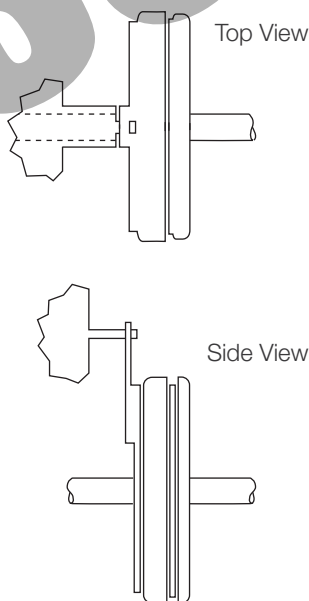

Figure 3:
Pin in Hole
Loosely
(Preferred)

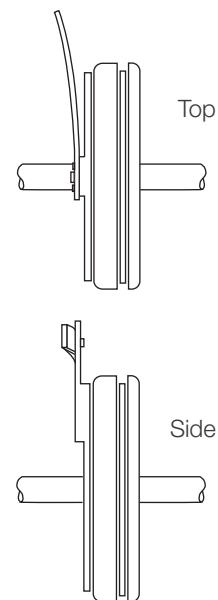

Figure 4:
Flexible Strap
(Preferred)

Electrical Data Coil Ratings

EC/EB-375	EC			EB		
Voltage – DC	90	24	6	90	24	6
Resistance @ 20° C – Ohms	453.5	29.3	2.10	446.8	29.3	1.96
Current – Amperes	.198	.82	2.85	.201	.82	3.07
Watts	17	20	17	18	20	18
Coil Build-up – milliseconds	62	60	59	50	60	52
Coil Decay – milliseconds	13	14	15	8	14	10

EC/EB-475	EC			EB		
Voltage – DC	90	24	6	90	24	6
Resistance @ 20° C – Ohms	368.9	37.8	2.32	443.1	28.8	2.05
Current – Amperes	.244	.64	2.58	.203	.88	2.93
Watts	22	15	16	18	21	18
Coil Build-up – milliseconds	92	91	90	80	75	70
Coil Decay – milliseconds	18	17	16	8	9	9

EC/EB-650	EC			EB		
Voltage – DC	90	24	6	90	24	6
Resistance @ 20° C – Ohms	225	17.7	1.16	257.2	18.3	1.24
Current – Amperes	.4	1.36	5.19	.35	1.3	4.84
Watts	36	33	31	32	31	29
Coil Build-up – milliseconds	120	115	110	112	108	105
Coil Decay – milliseconds	20	20	20	12	13	14

FB/ER-375, 475, 650	FB-375		FB-475		FB-650	
Resistance @ 20° C – Ohms	446	29	310	22	235	16
Current – Amperes	.201	.822	.800	1.09	.380	1.426
Watts	18	19	27	26	34	34
Coil Build-up – milliseconds	40	40	80	80	90	90
Coil Decay – milliseconds	5	10	8	10	10	10

ER-825, 1225	ER-825		ER-1225	
Voltage – DC	90		35-75	
Resistance @ 20° C – Ohms	304		235	
Current – Amperes	.29		.383	
Watts	26		35	
Coil Build-up – milliseconds	400		700	
Coil Decay – milliseconds	20		20	

EC/EB-825	EC			EB		
Voltage – DC	90	24	6	90	24	6
Resistance @ 20° C – Ohms	221	20.9	1.098	223.3	20.4	1.27
Current – Amperes	.407	1.15	5.464	.4	1.18	4.74
Watts	37	28	33	36	28	28
Coil Build-up – milliseconds	225	200	180	170	170	170
Coil Decay – milliseconds	130	122	115	80	75	70

EC/EB-1000	EC			EB		
Voltage – DC	90	24	6	90	24	6
Resistance @ 20° C – Ohms	248.7	19.7	1.23	248.7	19.7	1.23
Current – Amperes	.36	1.22	4.87	.36	1.22	4.87
Watts	33	29	29	33	29	29
Coil Build-up – milliseconds	250	235	220	235	220	205
Coil Decay – milliseconds	70	75	80	70	75	80

EC/EB-1225	EC			EB		
Voltage – DC	90	24	6	90	24	6
Resistance @ 20° C – Ohms	207.3	15.1	1.04	261.7	22.3	1.33
Current – Amperes	.43	1.59	5.79	.34	1.08	4.5
Watts	39	38	35	31	26	27
Coil Build-up – milliseconds	500	490	480	460	445	435
Coil Decay – milliseconds	220	230	240	190	160	140

ATC, ATTC, ATB, ATTB-25	ATC			ATB		
Voltage – DC	6	24	90	6	24	90
Resistance @ 20° C – Ohms	1.37	20.2	290	1.37	20.2	290
Current – Amperes	4.38	1.19	.31	4.38	1.19	.31
Watts	26.3	28.6	27.9	26.3	28.6	27.9
Coil Build-up – milliseconds	145	145	145	145	145	145
Coil Decay – milliseconds	8	8	8	9	9	9

ATC, ATTC, ATB, ATTB-55	ATC			ATB		
Voltage – DC	6	24	90	6	24	90
Resistance @ 20° C – Ohms	1.21	19.6	230	1.21	19.6	230
Current – Amperes	4.96	1.22	.39	4.96	1.22	.39
Watts	29.8	29.3	35.2	29.8	29.3	35.2
Coil Build-up – milliseconds	200	200	200	210	210	210
Coil Decay – milliseconds	20	20	20	35	35	35

ATC, ATTC, ATB, ATTB-115	ATC			ATB		
Voltage – DC	6	24	90	6	24	90
Resistance @ 20° C – Ohms	1.02	16.5	182	1.02	16.5	182
Current – Amperes	5.91	1.46	.50	5.91	1.46	.50
Watts	35.4	35	44.6	35.4	35	44.6
Coil Build-up – milliseconds	145	145	145	150	150	150
Coil Decay – milliseconds	40	40	40	45	45	45

Electrical Data Coil Ratings

(Blue shaded areas indicate GEN 2 design)

UM/EM/UMFB/EMFB		Clutch	UM/EM Brake	Clutch	UM/EM Brake	Clutch	UM/EM Brake	UMFB/EMFB Brake	UMFB/EMFB Brake
Voltage – DC		90	90	24	24	6	6	24	90
Resistance (ohms)	EM-50	452	429	31.8	28.8	1.9	1.9	28.8	429
	EM-100	392	392	26.7	26.7	1.8	1.8	21.7	308
	EM-180	392	392	26.7	26.7	1.8	1.8	21.7	308
	EM-210/215	248	248	17.9	17.9	1.22	1.22	13.3	205
Amperes	EM-50	.20	.21	.76	.83	3.2	3.2	.83	.21
	EM-100	.23	.23	.90	.90	3.3	3.3	1.1	.29
	EM-180	.23	.23	.90	.90	3.3	3.3	1.1	.29
	EM-210/215	.36	.36	1.3	1.3	4.9	4.9	1.8	.38
Watts	EM-50	18	19	19	20	20	20	20	19
	EM-100	21	21	22	22	20	20	27	27
	EM-180	21	21	22	22	20	20	27	27
	EM-210/215	33	33	32	32	30	30	43	34
Build-up (millisecond)	EM-50	52	53	52	53	52	53	40	40
	EM-100	72	75	72	75	72	70	80	80
	EM-180	72	75	72	75	72	70	80	80
	EM-210/215	120	100	120	100	110	100	90	90
Decay (millisecond)	EM-50	6	5	6	5	6	5	5	5
	EM-100	12	10	12	10	12	10	8	8
	EM-180	12	10	12	10	12	10	8	8
	EM-210/215	20	10	20	10	20	10	10	10

OBSOLETE

Electrical Data Coil Ratings

Unit Size	SF/PB 120			SF/PB 170			SF/PB 250		
Voltage – DC	6	24	90	6	24	90	6	24	90
Resistance @ 20°C – Ohms	6.32	104	1386	6.96	111.2	1506	5	76.4	1079
Current – Amperes	.949	.230	.065	.861	.215	.060	1.2	.314	.084
Watts	5.69	5.52	5.85	5.85	5.16	5.37	7.2	7.5	7.51
Coil Build-up – milliseconds	12	12	11	17	17	16	48	48	44
Coil Decay – milliseconds	8	8	7	8	7	6	15	15	13

Unit Size	SF/PB 400			SF-500			PB & PC 500			SF-650		
Voltage – DC	6	24	90	6	24	90	6	24	90	6	24	90
Resistance @ 20°C – Ohms	4.88	73	1087	1.076	14.9	206.1	1.36	23.8	251.1	1.16	17.7	225
Current – Amperes	1.23	.322	.083	5.58	1.61	.44	4.4	1.01	.36	5.19	1.36	.4
Watts	7.39	7.96	7.45	34	39	39	26	24	32	31	33	36
Coil Build-up – milliseconds	154	154	154	82	85	90	84	87	93	110	115	120
Coil Decay – milliseconds	62	60	55	40	40	40	38	35	30	50	50	50

Unit Size	PB-650			SF-825			SF-825 Brg			PB & PC 825			SF-1000			PB & PC 1000		
Voltage – DC	6	24	90	6	24	90	6	24	90	6	24	90	6	24	90	6	24	90
Resistance @ 20°C – Ohms	1.24	18.3	257.2	1.23	20.9	267.0	1.098	14.6	221	1.27	20.4	223.3	1.07	14.4	214.4	1.23	19.7	248.7
Current – Amperes	4.84	1.31	.35	4.9	1.15	.34	5.464	1.65	.407	4.74	1.18	.4	5.61	1.67	.42	4.87	1.22	.36
Watts	29	31	32	29	28	30	33	40	37	28	28	36	34	40	38	29	29	33
Coil Build-up – milliseconds	100	105	110	222	200	245	180	200	225	170	170	170	256	275	283	205	220	235
Coil Decay – milliseconds	50	50	50	105	120	100	115	120	130	70	75	80	123	105	90	70	75	80

Unit Size	SF-1225			PB & PC 1225			SF-1525			PB & PC 1525			SF-1525 H.T.	
Voltage – DC	6	24	90	6	24	90	6	24	90	6	24	90	6	90
Resistance @ 20°C – Ohms	1.21	19.5	268.3	1.33	22.3	261.7	1.11	15.5	239.1	1.45	19.8	258.4	55	113.4
Current – Amperes	4.97	1.23	.34	4.5	1.08	.34	5.41	1.55	.38	4.13	1.21	.35	10.83	.794
Watts	30	30	30	27	26	31	32	37	34	25	29	31	65	72
Coil Build-up – milliseconds	475	490	510	300	320	350	505	535	575	470	490	512	480	560
Coil Decay – milliseconds	240	230	220	190	190	190	230	237	215	200	170	140	210	160

NOTES: Build-up time equals current to approximately 90% of steady state value and flux to 90%. Decay time equals current to approximately 10% of steady state value and flux to 10%. Approximately because current leads or lags flux by a small amount.

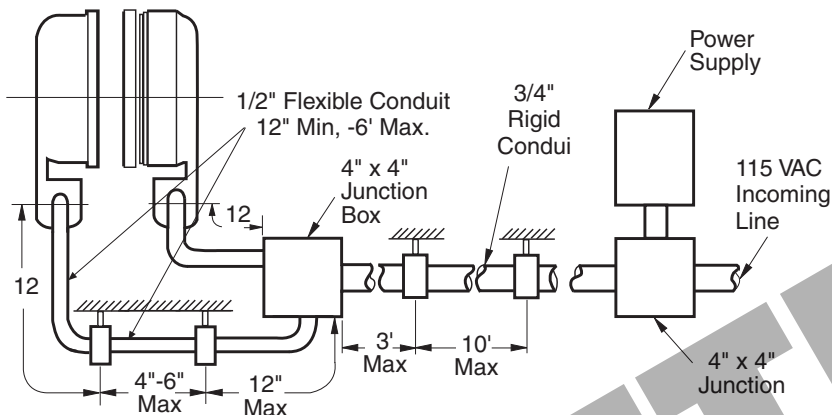

Recommended Electrical Installation Procedure for Warner Electric Clutches and Brakes

Warner Electric clutches and brakes conform to UL (Underwriters Laboratories) requirements. All packaged products come with conduit boxes or are enclosed in housings with provision for electrical conduit connection. All sizes 400 and larger SF clutch fields and brake magnets accept UL conforming conduit boxes available from Warner Electric.

The National Electrical Code (NEC) requires that conductors subject to physical damage be adequately protected. When electrical conduit is used, a minimum of 12" of 1/2" flexible conduit is to be used between each brake and/or clutch and its box. This construction will prevent improper bearing loading in bearing mounted units and ease field and magnet assembly and disassembly.

Refer to the information below for proper installation practices and wire sizes.

Notwithstanding the above recommendations, all electrical installations should conform to NEC and/or other governing electrical codes.

Recommended wire size versus maximum distance

Wire Size AWG	Fractional Horsepower Sizes 170-400			Integral Horsepower Sizes 500-1525		
	Distance (feet)			Distance (feet)		
	6 Volt	24 Volt	90 Volt	6 Volt	24 Volt	90 Volt
18	20	280	1000	4	65	700
16	30	430		6	95	
14	50	720		10	160	
12	75	720		10	160	
10	125			25	400	
8	200			40		

General construction wire type MTW or THW recommended.
 #6 terminal screws (size 400 and smaller) are to be torqued to 15 in.lb.
 #8 terminal screws (size 500 and larger) are to be torqued to 20 in.lb.

Electrical Data Coil Suppression & Clutch/Brake Overlap

Users of electric clutch and brake systems are sometimes concerned that a clutch and brake will oppose each other or “overlap” during switching, i.e., when the clutch is switched off and the brake is switched on, or vice versa. This concern relates primarily to dual armature type clutch/brakes similar to the Warner Electric Electro Module product line, as compared to shuttle armature clutch/brakes.

In use, Warner Electric clutches and brakes are not subject to overlap when simple coil suppression techniques are applied to the clutch/brake control. All Warner Electric clutch/brake controls use suppression to eliminate any overlap situations.

The charts below graphically display clutch current decay and the current rise of the brake with and without current suppression. In Chart 1, which shows brake and clutch operation with suppression, the “Overlap Area” below the intersection of the brake and clutch current lines shows potential for the

devices to fight one another. But this intersection occurs at an extremely low current level and the armature Autogap™ springs keep the friction surfaces of the brake armature and magnet separate at such low currents. Even though there is the appearance of a minor clutch/brake overlap in this instance, the brake armature has not yet contacted the brake magnet. Chart 2 shows a much larger overlap area since no coil suppression is used in this circuit. Clutch current has not decayed fully as the brake is engaged and the load is brought to zero speed.

Clutch and brake coils are inductors. Inductance is the electrical equivalent to mechanical inertia and an energized coil dissipates its energy when turned “off.” Upon removal of power, polarity across an inductor reverses and current flows in the opposite direction. Without suppression in the control circuit, an arc can result from the strength of this current flow which can damage the electrical switching contacts.

Consequently, suppression circuitry has two major benefits:

- Protects the switching contacts
- Hastens coil decay

The schematics below show circuits with no suppression and both diode and zener suppression types.

The rapid coil decay of suppression circuitry lets users enjoy the major advantages which dual armatures have over single, “shuttle” armatures. These include:

- Better heat dissipation – greater area to give off heat and more “off” time
- Longer life – two armatures absorb wear
- Self adjusting for the life of the unit
- Enhanced repeatability – armatures may remain in light contact with their mating surface, eliminating armature movement time and reducing noise and spline wear.

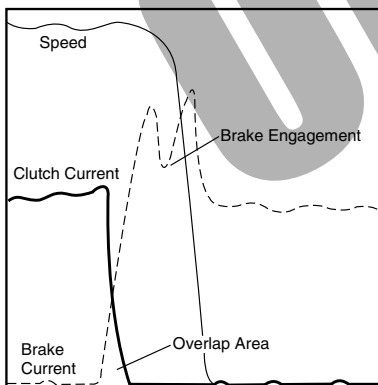

Chart 1

Brake Engagement with Zener Diode Suppression

Clutch current decay and brake current rise overlap, but the brake armature is not engaged until well past the overlap point. Note that the “blip” in the brake current trace coincides with the sharp decline in the “speed” trace, indicating brake armature engagement at that point.

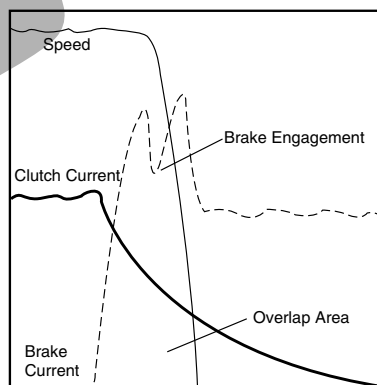
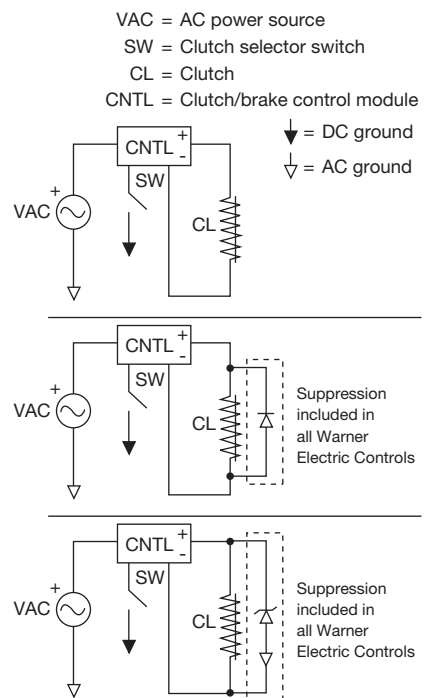

Chart 2

Brake Engagement with No Suppression

Clutch current decay is much slower than with suppression as shown in Chart 1, greatly increasing the overlap area. The current level in the clutch coil is much higher at the point of brake engagement than with the suppression circuit.



Overexcitation is a technique which makes a clutch or brake engage faster and have greatly improved starting and stopping accuracy. It involves applying over voltage to the clutch or brake coil to reduce current build up time, thereby reducing the magnetizing time.

The graphs below show current rise and shaft speed for an identical system using a Warner Electric EP-400 clutch/brake both with and without overexcitation. The effect of overexcitation is to reduce the time needed to achieve full current and thereby reduce the time required to achieve full speed with a clutch or zero speed with a brake. In the example below, "time to start" is approximately

70 ms without overexcitation. This is reduced to 30 ms when overexcitation is applied. This time is comparable to the coil buildup times stated on page 194. The "time to stop" has been similarly reduced; the nominally excited system requires about 110 ms to stop the load, while this is accomplished in only 50 ms with overexcitation.

Overexcitation does not increase torque. Rather, the reduction in start-stop times comes from reduced coil current build up times (or "time to current"). For many common industrial applications, the reduction in "time to speed" and "time to stop" is one half when using overexcitation.

The use of overexcitation on a clutch/brake system does not increase system wear. In fact, the clutch/brake wear rate may be reduced because slippage and energy dissipation is marginally reduced in the clutch/brake. Compliance in the drivetrain may absorb some of the start/stop inertia or wear may be observed in other drivetrain components. Whenever overexcitation is used, adequate coil suppression must be employed. Please refer to "Coil Suppression and Clutch/Brake Overlap" on page 196.

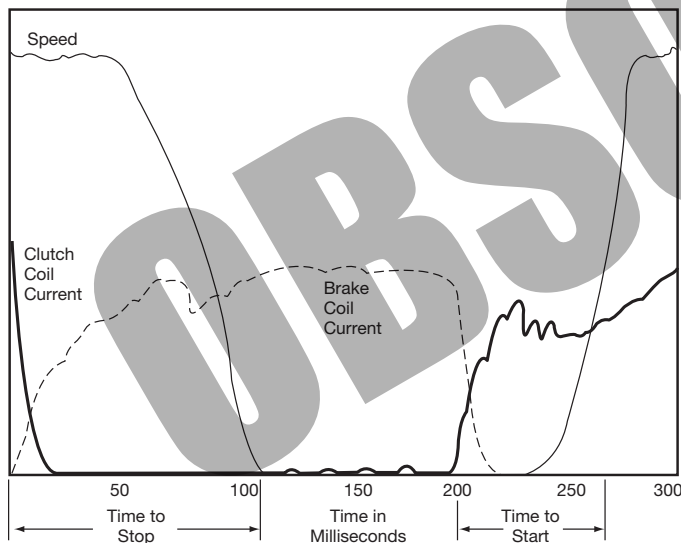

Chart 1

Without Overexcitation

Current/speed trace of EP400 clutch/brake being run through a single stop/start cycle. Note that 110 milliseconds is required to stop from the time the clutch coil is de-energized and the brake coil is energized. At the 200 milliseconds point on the graph the clutch coil is energized and the load is at speed 70 milliseconds later. Note that the coil current is still increasing after the load is at full speed.

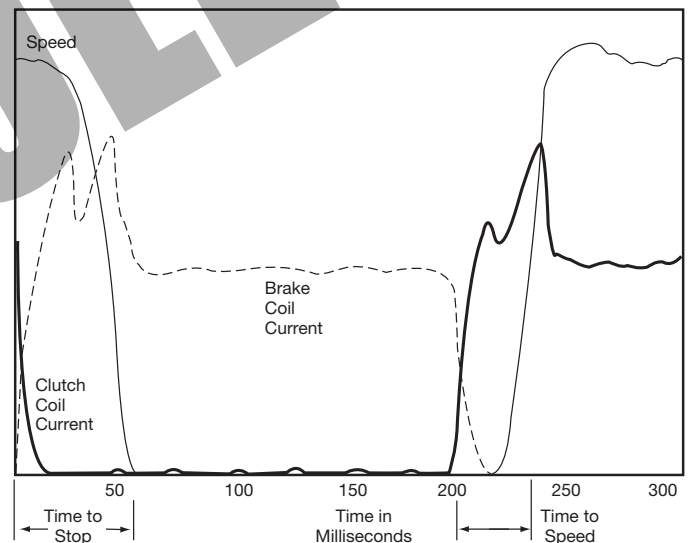

Chart 2

With Overexcitation

Current/speed trace of EP400 clutch/brake being run through a single stop/start cycle. With overexcitation, both brake and clutch coil currents build much faster with concurrent reductions in both stop and start times, when compared with Chart 1.

Bushing Part Numbers

Browning® Bushing

Shaft Size	Keyway Size	Bushing Number	
		Warner Electric	Browning
1/2	1/8 x 1/16	180-0002	
9/16	1/8 x 1/16	180-0003	
5/8	3/16 x 3/32	180-0004	
11/16	3/16 x 3/32	180-0005	
3/4	3/16 x 3/32	180-0006	
13/16	3/16 x 3/32	180-0007	
7/8	3/16 x 3/32	180-0008	
15/16	1/4 x 1/8	180-0009	H Type-1
1	1/4 x 1/8	180-0010	
1 1/16	1/4 x 1/8	180-0011	
1 1/8	1/4 x 1/8	180-0012	
1 3/16	1/4 x 1/8	180-0013	
1 1/4	1/4 x 1/8	180-0014	
1 5/16	5/16 x 5/32	180-0015	
1 3/8	5/16 x 5/32	180-0016	
1 7/16	3/8 x 3/16	180-0017	H Type-2
1 1/2	3/8 x 3/16	180-0018	
3/4	3/16 x 3/32	180-0026	
13/16	3/16 x 3/32	180-0027	
7/8	3/16 x 3/32	180-0028	
15/16	1/4 x 1/8	180-0029	
1	1/4 x 1/8	180-0030	
1 1/16	1/4 x 1/8	180-0031	
1 1/8	1/4 x 1/8	180-0032	
1 3/16	1/4 x 1/8	180-0033	
1 1/4	1/4 x 1/8	180-0034	
1 5/16	5/16 x 5/32	180-0035	Q1 Type-1
1 3/8	5/16 x 5/32	180-0036	
1 7/16	3/8 x 3/16	180-0037	
1 1/2	3/8 x 3/16	180-0038	
1 9/16	3/8 x 3/16	180-0039	
1 5/8	3/8 x 3/16	180-0040	
1 11/16	3/8 x 3/16	180-0041	
1 3/4	3/8 x 3/16	180-0042	
1 13/16	1/2 x 1/4	180-0043	
1 7/8	1/2 x 1/4	180-0044	
1 15/16	1/2 x 1/4	180-0045	
2	1/2 x 1/4	180-0046	
2 1/16	1/2 x 1/4	180-0047	
2 1/8	1/2 x 1/4	180-0048	
2 3/16	1/2 x 1/4	180-0049	
2 1/4	1/2 x 1/4	180-0050	
2 5/16	5/8 x 5/16	180-0051	Q1 Type-2
2 3/8	5/8 x 5/16	180-0052	
2 7/16	5/8 x 5/16	180-0053	
2 1/2	5/8 x 5/16	180-0054	
2 9/16	5/8 x 5/16	180-0055	
2 5/8	5/8 x 5/16	180-0056	
2 11/16	5/8 x 5/16	180-0057	

(Browning® is registered to Emerson Electric Co.)

Dodge Bushing

Shaft Size	Keyway Size	Bushing Number	
		Warner Electric	Dodge
1/2	1/8 x 1/16	180-0101	
9/16	1/8 x 1/16	180-0102	
5/8	3/16 x 3/32	180-0103	
11/16	3/16 x 3/32	180-0104	
3/4	3/16 x 3/32	180-0105	
13/16	3/16 x 3/32	180-0106	1210
7/8	3/16 x 3/32	180-0107	
15/16	1/4 x 1/8	180-0108	
1	1/4 x 1/8	180-0109	
1 1/16	1/4 x 1/8	180-0110	
1 1/8	1/4 x 1/8	180-0111	
1 3/16	1/4 x 1/8	180-0112	
1 1/4	1/4 x 1/8	180-0113	
1/2	1/8 x 1/16	180-0116	
9/16	1/8 x 1/16	180-0117	
5/8	3/16 x 3/32	180-0118	
11/16	3/16 x 3/32	180-0119	
3/4	3/16 x 3/32	180-0120	
13/16	3/16 x 3/32	180-0121	1215
7/8	3/16 x 3/32	180-0122	
15/16	1/4 x 1/8	180-0123	
1	1/4 x 1/8	180-0124	
1 1/16	1/4 x 1/8	180-0125	
1 1/8	1/4 x 1/8	180-0126	
1 3/16	1/4 x 1/8	180-0127	
1 1/4	1/4 x 1/8	180-0128	
1/2	1/8 x 1/16	180-0131	
9/16	1/8 x 1/16	180-0132	
5/8	3/16 x 3/32	180-0133	
11/16	3/16 x 3/32	180-0134	
3/4	3/16 x 3/32	180-0135	
13/16	3/16 x 3/32	180-0136	
7/8	3/16 x 3/32	180-0137	
15/16	1/4 x 1/8	180-0138	
1	1/4 x 1/8	180-0139	
1 1/16	1/4 x 1/8	180-0140	1615
1 1/8	1/4 x 1/8	180-0141	
1 3/16	1/4 x 1/8	180-0142	
1 1/4	1/4 x 1/8	180-0143	
15/16	5/16 x 5/32	180-0144	
13/8	5/16 x 5/32	180-0145	
17/16	3/8 x 3/16	180-0146	
1 1/2	3/8 x 3/16	180-0147	
19/16	3/8 x 3/16	180-0148	
15/8	3/8 x 3/16	180-0149	
1/2	1/8 x 1/16	180-0155	
9/16	1/8 x 1/16	180-0156	
5/8	3/16 x 3/32	180-0157	
11/16	3/16 x 3/32	180-0158	
3/4	3/16 x 3/32	180-0159	
13/16	3/16 x 3/32	180-0160	
7/8	3/16 x 3/32	180-0161	2012
15/16	1/4 x 1/8	180-0162	
1	1/4 x 1/8	180-0163	
1 1/16	1/4 x 1/8	180-0164	
1 1/8	1/4 x 1/8	180-0165	
1 3/16	1/4 x 1/8	180-0166	
1 1/4	1/4 x 1/8	180-0167	

Bushing Part Numbers

Dodge Bushing – Continued

		Bushing Number				Bushing Number				Bushing Number	
Shaft Size	Keyway Size	Warner Electric	Dodge	Shaft Size	Keyway Size	Warner Electric	Dodge	Shaft Size	Keyway Size	Warner Electric	Dodge
15/16	5/16 x 5/32	180-0168		111/16	3/8 x 3/16	180-0235		1/2	1/8 x 1/16	180-0326	
13/8	5/16 x 5/32	180-0169		13/4	3/8 x 3/16	180-0236		9/16	1/8 x 1/16	180-0327	
17/16	3/8 x 3/16	180-0170		113/16	1/2 x 1/4	180-0237		5/8	3/16 x 3/32	180-0328	
11/2	3/8 x 3/16	180-0171		17/8	1/2 x 1/4	180-0238		11/16	3/16 x 3/32	180-0329	
19/16	3/8 x 3/16	180-0172		115/16	1/2 x 1/4	180-0239		3/4	3/16 x 3/32	180-0330	
15/8	3/8 x 3/16	180-0173	2012	2	1/2 x 1/4	180-0240		13/16	3/16 x 3/32	180-0331	
111/16	3/8 x 3/16	180-0174		21/16	1/2 x 1/4	180-0241		7/8	3/16 x 3/32	180-0332	
13/4	3/8 x 3/16	180-0175		21/8	1/2 x 1/4	180-0242		15/16	1/4 x 1/8	180-0333	
113/16	1/2 x 1/4	180-0176		23/16	1/2 x 1/4	180-0243		1	1/4 x 1/8	180-0334	1610
17/8	1/2 x 1/4	180-0177		21/4	1/2 x 1/4	180-0244		11/16	1/4 x 1/8	180-0335	
115/16	1/2 x 1/4	180-0178		25/16	5/8 x 5/16	180-0245	3020	11/8	1/4 x 1/8	180-0336	
2	1/2 x 1/4	180-0179		23/8	5/8 x 5/16	180-0246		13/16	1/4 x 1/8	180-0337	
1/2	1/8 x 1/16	180-0185		27/16	5/8 x 5/16	180-0247		11/4	1/4 x 1/8	180-0338	
9/16	1/8 x 1/16	180-0186		21/2	5/8 x 5/16	180-0248		15/16	5/16 x 5/32	180-0339	
5/8	3/16 x 3/32	180-0187		29/16	5/8 x 5/16	180-0249		13/8	5/16 x 5/32	180-0340	
11/16	3/16 x 3/32	180-0188		25/8	5/8 x 5/16	180-0250		17/16	3/8 x 3/16	180-0341	
3/4	3/16 x 3/32	180-0189		211/16	5/8 x 5/16	180-0251		11/2	3/8 x 3/16	180-0342	
13/16	3/16 x 3/32	180-0190		23/4	5/8 x 5/16	180-0252		19/16	3/8 x 3/16	180-0343	
7/8	3/16 x 3/32	180-0191		213/16	3/4 x 3/8	180-0253		15/8	3/8 x 3/16	180-0344	
15/16	1/4 x 1/8	180-0192		27/8	3/4 x 3/8	180-0254		1/2	1/8 x 1/16	180-0410	
1	1/4 x 1/8	180-0193		215/16	3/4 x 3/8	180-0255		9/16	1/8 x 1/16	180-0411	
11/16	1/4 x 1/8	180-0194		3	3/4 x 3/8	180-0256		5/8	3/16 x 3/32	180-0412	
11/8	1/4 x 1/8	180-0195		15/16	1/4 x 1/8	180-0262		11/16	3/16 x 3/32	180-0413	
13/16	1/4 x 1/8	180-0196		1	1/4 x 1/8	180-0263		3/4	3/16 x 3/32	180-0414	1008
11/4	1/4 x 1/8	180-0197		11/16	1/4 x 1/8	180-0264		3/16	3/16 x 3/32	180-0415	
15/16	5/16 x 5/32	180-0198		11/8	1/4 x 1/8	180-0265		7/8	3/16 x 3/32	180-0416	
13/8	5/16 x 5/32	180-0199		13/16	1/4 x 1/8	180-0266		15/16	1/4 x 1/8	180-0417	
17/16	3/8 x 3/16	180-0200		11/4	1/4 x 1/8	180-0267		1	1/4 x 1/8	180-0418	
11/2	3/8 x 3/16	180-0201	2517	15/16	5/16 x 5/32	180-0268		1/2	1/8 x 1/16	180-0421	
19/16	3/8 x 3/16	180-0202		13/8	5/16 x 5/32	180-0269		9/16	1/8 x 1/16	180-0422	
15/8	3/8 x 3/16	180-0203		17/16	3/8 x 3/16	180-0270		5/8	3/16 x 3/32	180-0423	
111/16	3/8 x 3/16	180-0204		11/2	3/8 x 3/16	180-0271		11/16	3/16 x 3/32	180-0424	
13/4	3/8 x 3/16	180-0205		19/16	3/8 x 3/16	180-0272		3/4	3/16 x 3/32	180-0425	
113/16	1/2 x 1/4	180-0206		15/8	3/8 x 3/16	180-0273		13/16	3/16 x 3/32	180-0426	
17/8	1/2 x 1/4	180-0207		111/16	3/8 x 3/16	180-0274		7/8	3/16 x 3/32	180-0427	
115/16	1/2 x 1/4	180-0208		13/4	3/8 x 3/16	180-0275		15/16	1/4 x 1/16	180-0428	1310
2	1/2 x 1/4	180-0209		113/16	1/2 x 1/4	180-0276		1	1/4 x 1/8	180-0429	
21/16	1/2 x 1/4	180-0210		17/8	1/2 x 1/4	180-0277	3030	11/16	1/4 x 1/8	180-0430	
21/8	1/2 x 1/4	180-0211		115/16	1/2 x 1/4	180-0278		11/8	1/4 x 1/8	180-0431	
23/16	1/2 x 1/4	180-0212		2	1/2 x 1/4	180-0279		13/16	1/4 x 1/8	180-0432	
21/4	1/2 x 1/4	180-0213		21/16	1/2 x 1/4	180-0280		11/4	1/4 x 1/8	180-0433	
25/16	5/8 x 5/16	180-0214		21/8	1/2 x 1/4	180-0281		15/16	5/16 x 5/32	180-0434	
23/8	5/8 x 5/16	180-0215		23/16	1/2 x 1/4	180-0282		13/8	5/16 x 5/32	180-0435	
27/16	5/8 x 5/16	180-0216		21/4	1/2 x 1/4	180-0283					
21/2	5/8 x 5/16	180-0217		215/16	5/8 x 5/16	180-0284					
15/16	1/4 x 1/8	180-0223		23/8	5/8 x 5/16	180-0285					
1	1/4 x 1/8	180-0224		27/16	5/8 x 5/16	180-0286					
11/16	1/4 x 1/8	180-0225		21/2	5/8 x 5/16	180-0287					
11/8	1/4 x 1/8	180-0226		29/16	5/8 x 5/16	180-0288					
13/16	1/4 x 1/8	180-0227		25/8	5/8 x 5/16	180-0289					
11/4	1/4 x 1/8	180-0228		211/16	5/8 x 5/16	180-0290					
15/16	5/16 x 5/32	180-0229	3020	23/4	5/8 x 5/16	180-0291					
13/8	5/16 x 5/32	180-0230		213/16	3/4 x 3/8	180-0292					
17/16	3/8 x 3/16	180-0231		27/8	3/4 x 3/8	180-0293					
11/2	3/8 x 3/16	180-0232		215/16	3/4 x 3/8	180-0294					
19/16	3/8 x 3/16	180-0233		3	3/4 x 3/8	180-0295					
15/8	3/8 x 3/16	180-0234									

Warner Electric's electronic controls are designed to provide simple setup and maximum performance when used with electric clutches and brakes. Our controls offer a range of functions from on-off to torque control to over-excitation.

Selection

Many parameters beyond function can impact control selection. Warner Electric produces a variety of control options to suit numerous application requirements. Control selection parameters include:

- Mounting Location – Panel or conduit box mounting
- Switching – Relay switching of A.C. or D.C. lines or solid state switching
- Output Voltage – Controls are available for 6, 24 and 90 VDC clutch/brake coils
- Input Voltage – Controls with input power transformers are available for connection to high voltage mains.

If your application requires something special, please call us. We will be happy to provide solutions.

Clutch and Brake Controls 202

On-Off Controls

CBC-100	204
CBC-150	204
CBC-160	205
CBC-801	206
CBC-802	207
CBC-400 (Obsolete, replaced by CBC-500)	208
CBC-450 (Obsolete, replaced by CBC-550)	209

Adjustable Torque Controls

MCS-103-1	210
MCS-805-1	211
MCS-805-2	211
CBC-200 <i>(Obsolete, replaced by CBC-300)</i>	212
CBC-300	214
CBC-500	216
CBC-550	218
CBC-1825R	220

Overexcitation Controls

CBC-700	222
CBC-750	224

Appendix 226

Questions & Answers 227

Ordering Information 228



Clutch and Brake Controls

Functions

On-Off (Basic start-stop)

Many applications are controlled by energizing the clutches and brakes with their rated D.C. voltages. Warner Electric controls are available with various mounting, input voltage and switching options.

Adjustable Torque

(Soft start-stop)

The torque transmitted by a clutch or brake is proportional to the coil current. Warner Electric offers several products that provide torque control for smooth and repeatable starts and stops.

Adjustable Accel-Decel

(Soft start-stop with full torque)

Warner Electric offers a control that allows for adjustment of the acceleration and deceleration time ramps to achieve a repeatable soft start or stop while still allowing for full torque.

Overexcitation

(Rapid cycling)

The clutch/brake speed of response can be increased for improved accuracy and performance through overexcitation, which is the application of a short high voltage pulse to provide nearly instantaneous torque.

Control Type

On-Off
Conduit Box
Mount



On-Off
Octal Socket
Mount



Adjustable
Torque



Adjustable Accel-Decel



Overexcitation



Clutch and Brake Controls

Model Number	No. of Channels	Torque Control Channels	A.C. Input Voltages	D.C. Output Voltages	Over-Excitation	Customer Supplied Switching Options	Description	Page Number
CBC-100-1	1	No	120	90	No	Relay A.C.	Single channel control to mount inside standard conduit box	204
CBC-100-2	1	No	220/240					
CBC-150-1	2	No	120	90	No	Relay A.C.	Dual channel control for clutch/brake to mount inside module conduit box	204
CBC-150-2	2	No	220/240					
CBC-160-1			120					
CBC-160-2	1	1	220/240	90	No	Relay A.C.	Single channel control with torque adjust for module electrically released brakes	205
CBC-801-1	2	No	120	90	No	Relay D.C.	Dual channel control for 2 clutches and/or brakes	206
CBC-801-2	2		220/240					
CBC-802	2	No	120	90	No	Transistor or Relay D.C.	Dual channel control with transistor switching	207
MCS-103-1	2	1	120	90	No	Relay D.C.	Dual channel control with torque adjust for one channel	210
MCS-805-1	1	1	120/240	35-75	No	Relay D.C.	Single adjustable channel control for use with ER-1225 brake.	211
MCS-805-2								
CBC-300	2	2	120	90	No	Transistor or Relay D.C.	Dual channel adjustable current control	214-
CBC-300-1								
CBC-500-90	2	2	120	90	No		Dual channel control for two clutches and/or brakes with	216-
CBC-500-24	2	2	24-30	24	No	Transistor or Relay D.C.	two torque adjust channels;	219
CBC-550-90	2	2	120/220/240/380/480	90	No		Emergency stop input	
CBC-550-24	2	2	120/220/240/380/480	24	No			
CBC-1825-R	2	2	120	90	No	Transistor or Relay D.C.	Dual channel adjustable time ramp with short circuit protection	220-221
CBC-700-90	2	No	120	90	Yes	Transistor or Relay D.C.	Dual channel compact overexcitation control for 24 or 90 volt clutches and brakes	222-223
CBC-700-24	2		24-28	24				
CBC-750-6	2	2	120/220/240	6	Yes	Transistor, Relay D.C. or Triac A.C.	Dual channel full function overexcitation control; provides input/output logic, torque adjustable current and remote inputs	224-225

CBC-100/CBC-150 On-Off Controls

Integral/Conduit Box Mounted Controls

The CBC-100 and CBC-150 series are UL listed, conduit box mounted controls for 90 volt clutches and brakes. Models are available for either 120 VAC or 220/240 VAC input.



CBC-100 series Single unit capacity

The CBC-100 mounts inside a standard Warner Electric conduit box and includes rectification and suppression circuits.

- US
- Compact
- Single channel
- Mounts inside conduit box



CBC-150 series Dual channel capacity

The CBC-150 replaces the cover on the standard module conduit box (part no. 5370-101-042). Provides rectification and suppression for two devices. Green LED indicates power to clutch. Red LED indicates power to brake.

- US
- Dual channel
- Replaces the cover on the module conduit box

Specifications

	CBC-100-1	CBC-100-2	CBC-150-1	CBC-150-2
Part No.	6003-448-101	6003-448-103	6004-448-001	6004-448-002
Input	120 VAC 50/60 Hz	220/240 VAC 50/60 Hz	120 VAC 50/60 Hz	220/240 VAC 50/60 Hz
Output	90 VDC full wave rectified .8 Amp max.	90 VDC half wave rectified .8 Amp	90 VDC full wave rectified Dual .8 Amp	90 VDC half wave rectified Dual .8 Amp
Ambient Temperatures	-20° to 113°F (-29° to 45°C)			
Switching	External to control, accomplished on A.C. line using relay or triac.			
	SPST	SPST	SPDT	SPDT
Solid State (maximum leakage current <2 mA)	140 VAC, 1 Amp min.	280 VAC, 1 Amp min.	140 VAC, 2 Amp min.	280 VAC, 2 Amp min.
Electro- mechanical	120 VAC, 1 Amp min.	240 VAC, 1 Amp min.	120 VAC, 1 Amp min.	240 VAC, 1 Amp min.

Connection diagrams

CBC-100-1, -2

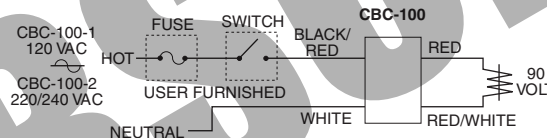

Dimensions

CBC-100-1, -2

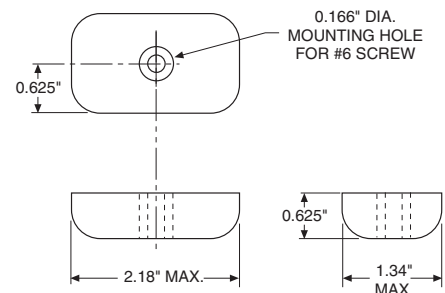

CBC-150-1, -2

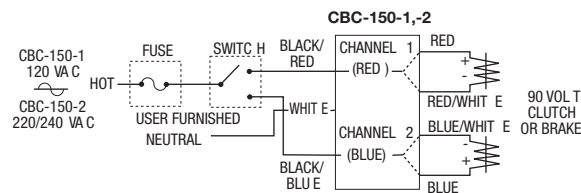

CBC-150-1, -2

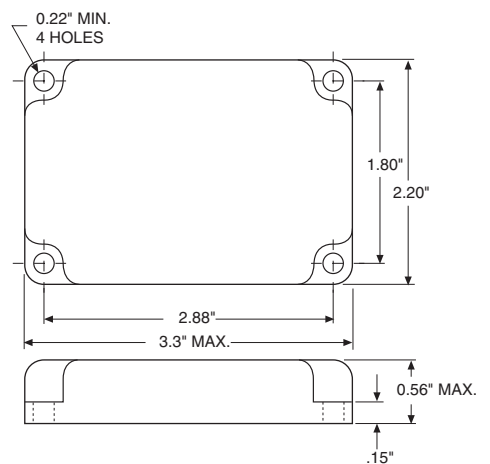

All dimensions nominal unless otherwise specified.

Integral/Electrically Released Motor Brake Controls

CBC-160

The CBC-160 series clutch/brake controls provide a single 90 VDC adjustable output for use with any clutch/brake unit. The adjustable output will provide consistent and repeatable release for Warner Electric's 90 VDC permanent magnet electrically released brakes. The CBC-160 mounts as the cover on the standard module conduit box (part number: 5370-101-042).



The 160-1 accommodates 120 volts A.C. motors.

- Adjustable 30-100 VDC
- LED indicator
- 120 volt A.C. input

The power to the 160-2 control can come from either a 230 volt or 460 volt A.C. motor. Customer-provided switching is accomplished through the motor starter on the A.C. input. This allows convenient retrofit of spring-set style motor brakes and inexpensive installation of new applications.

- Adjustable 30-100 VDC
- Power from motor
- Easy retrofit
- 230/460 motors

Dimensions

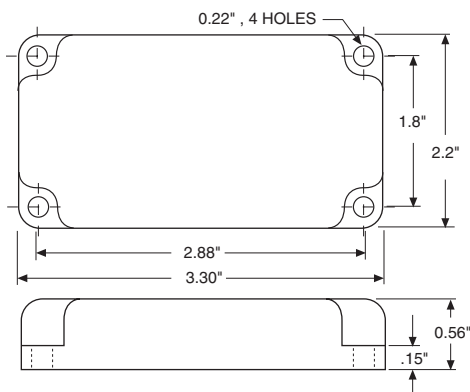

All dimensions nominal unless otherwise specified.

Specifications

	CBC-160-1	CBC-160-2
Part No.	6013-448-001	6013-448-002
Input	120 VAC, 50/60 Hz	220/240 VAC, 60 Hz, 1 Phase, 100 VA max.
Status Indicator	Red LED indicates power to the brake	—
Output	Single Channel, 30-100 VDC half-wave rectified nominal, 0.8 Amps maximum	
Ambient Temperatures	0° to 122°F (-18° to 50°C)	
Switching	Accomplished through motor starter or on A.C. line using relay or triac	

Connection Diagrams

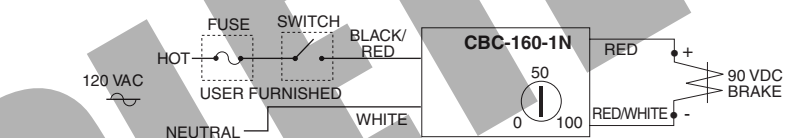

WYE Connected Motor

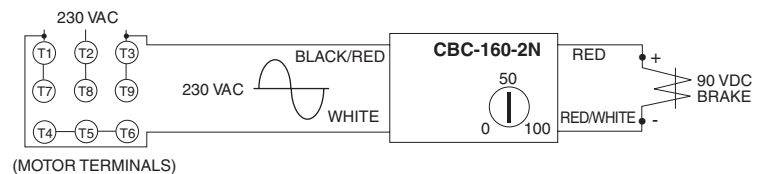
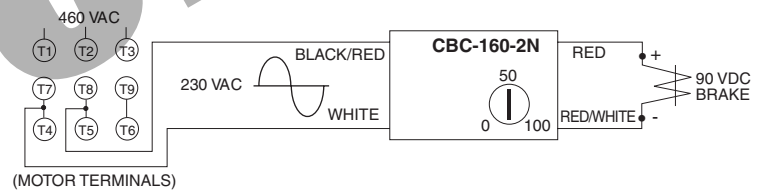

DELTA Connected Motor

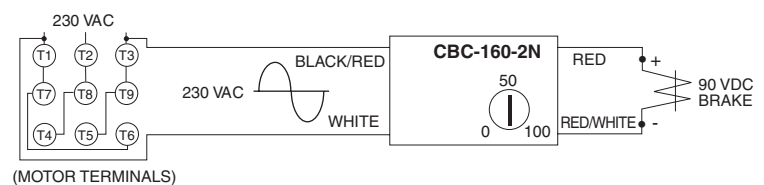
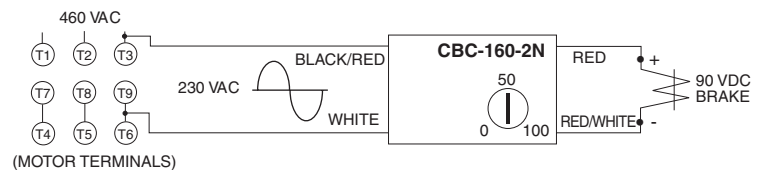

CBC-801 On-Off Controls

Plug-in Octal Socket Power Supplies

The CBC-801 is a basic on-off power supply that provides full voltage to a 90 volt clutch or brake and is activated by an external switch. This type of power supply is sufficient for many clutch/brake applications.

CBC-801 series Multi-unit capacity

The CBC-801 is a plug-in power supply which is used with an octal socket. The wiring connections are made at the socket. The CBC-801 will operate two units separately—or simultaneously. Octal socket is purchased separately.

Dimensions

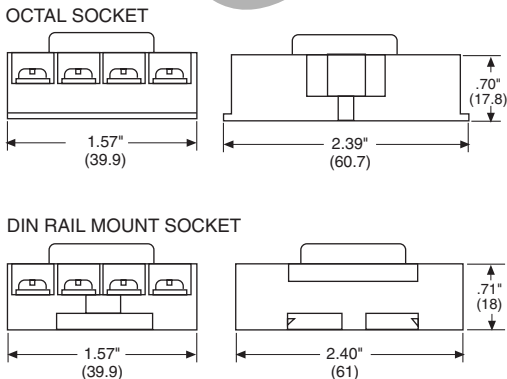
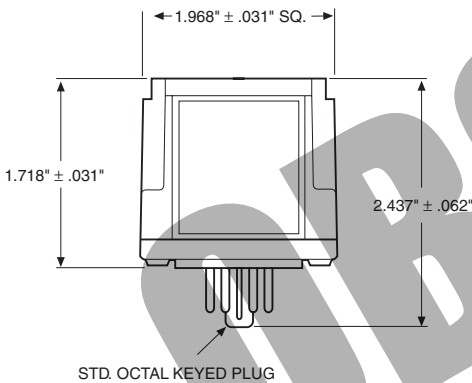

All dimensions nominal unless otherwise specified.

- ULus
- For basic on-off operation
- Wiring connections made at octal socket
- Arc suppression circuitry extends switch life
- Fused for overload protection
- LED output indicators
- DIN rail mountable



Specifications

	CBC-801-1	CBC-801-2
Part No.	6001-448-004	6001-448-006
Input Voltage	120 VAC, 50/60 Hz	220/240 VAC, 50/60 Hz
Output	90 VDC, 1.25 A max.	
Circuit Protection	Fused 1.6 Amp, 250 V fast-blo	
Ambient Temperature	-23° to 116°F (-31° to 47°C)	
Max. Cycle Rate	Limited by the clutch or brake, variable with application	
Switching	Single pole, double throw Minimum contact rating: 10 Amp, 28 VDC resistive or 10 Amp, 120 VAC inductive	
Status Indicator	Red LED indicates brake is energized, Green LED indicates clutch is energized	
Mounting	Two versions of octal socket are available: 6001-101-001 foot mount 6001-101-002 DIN rail mount	

Connection Diagrams

Connection diagram for operating clutch/brake separately.

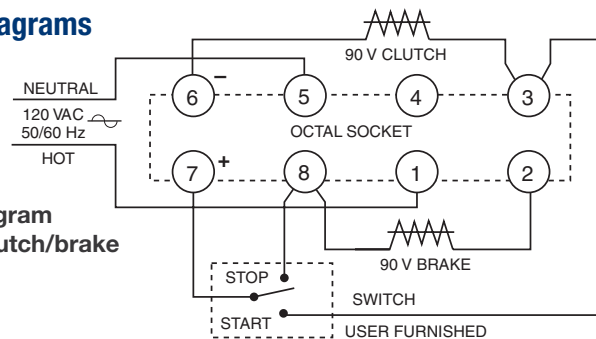

Connection diagram for operating clutch/brake simultaneously.

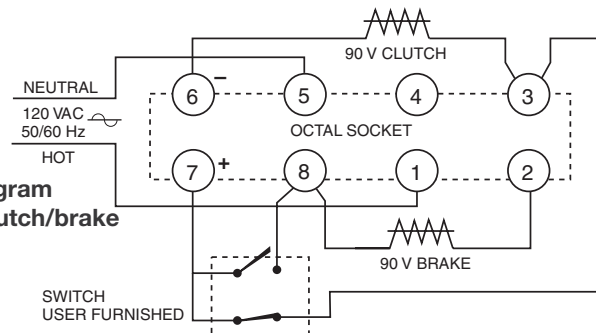



CBC-802 PLC compatible

The CBC-802 is a power supply with solid state switching circuits for load switching. A brake and clutch may be operated separately—or, two brakes or two clutches, one unit on at a time. The CBC-802 mounts on an octal socket (purchased separately), and the wiring connections are made at the socket terminals. Octal socket sold separately, refer to mounting specifications for part number.

- Plug-in power supply with solid state switching circuits—increases switch service life
- Adjustable time delay for controlling clutch/brake overlap
- Internally fused for overload protection
- DIN rail mountable
- LED output indicators

Dimensions

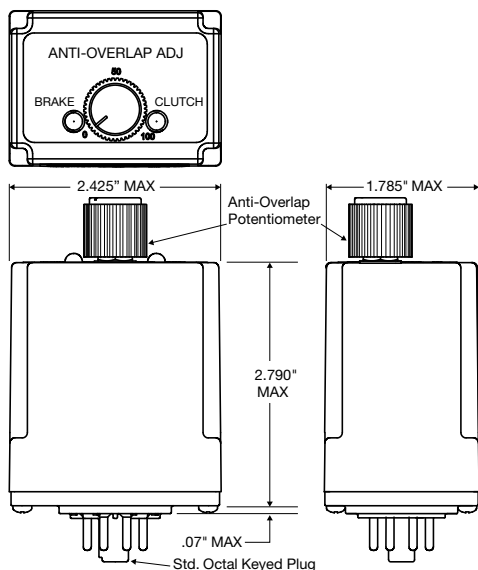

Specifications

CBC-802	
Part No.	6002-448-002
Input	120 VAC, 50/60 Hz
Output	90 VDC, 0.5 A max.
Status Indicator	Red LED indicates brake energized. Green LED indicates clutch energized.
Circuit Protection	Fused 0.5 Amps, 250 V
Ambient Temperature	-20° to 113°F (-29° to 45°C)
Leakage Current	500 uA max. for solid state switches
Max. Cycle Rate	Limited by the clutch or brake, variable with application
Switching	Momentary contact, maintained contact, or solid state open collector logic Minimum contact rating 20 VDC resistive, 0.01 Amps Minimum input pulse—1 millisecond
Adjustments	Externally adjusted potentiometer sets overlap between clutch and brake from 0 to 130 MS.
Mounting:	Two versions of octal socket are available: 6001-101-001 foot mount 6001-101-002 DIN rail mount

Connection Diagram

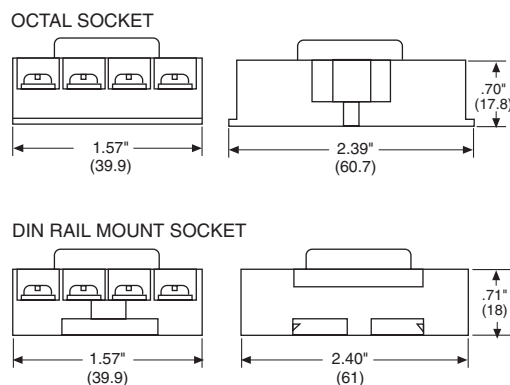
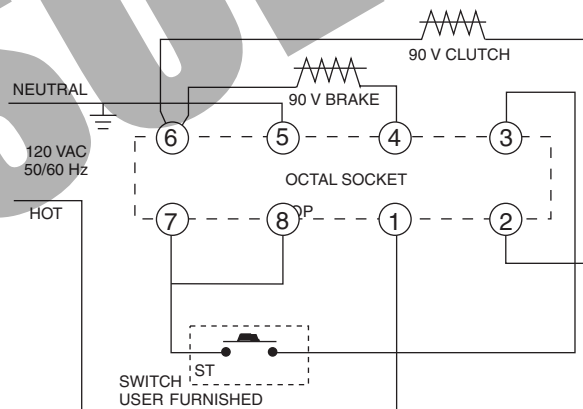

All dimensions nominal unless otherwise specified.

CBC-400 On-Off Controls

Panel Mounted Control



CBC-400 series Dual channel controls

The CBC-400 series is a basic on-off control which supplies 24 or 90 VDC for electric clutch/brake operation. They offer optically isolated switching inputs for start, stop, and emergency stop (E-stop). These controls can be set up to operate the two outputs alternately (single) or simultaneously (dual). Refer to the Appendix for additional setup and switching information.

- 24 or 90 Volt DC output
- Auxiliary 12V supply
- Fast coil suppression
- Single or dual channel operation
- Optically isolated input switching

Specifications

	CBC-400-90	CBC-400-24
Part No.	6006-448-003	6006-448-002
Input Voltage	120 VAC	24-30 VAC
Output Voltage	90 VDC	24 VDC
Output Current	1 Amp/Channel 2 Amps Total	5 Amps/Channel 5 Amps Total
Auxiliary Supply	12 VDC 250 mA	
Circuit Protection	Fused 2.5 Amp, 250 V fast-blo	Fused 6.3 Amp, 250 V fast-blo
Ambient Temperature	+32° to 122°F (0° to 50°C)	
Status Indicators	Red LED indicates channel is energized.	
Adjustments	Jumper for single or dual operation. See Appendix for explanation.	
Inputs	3 Optically isolated, 10-30 VDC, 3-9 mA for Channel 1, Channel 2 and Channel 2 override (applies full voltage to channel 1 output).	

Enclosure (Optional)



- Lift off hinge
- Quick-release latches
- Conforms to NEMA Type 13
- European Standard IEC 529, IP65

Connection Diagram

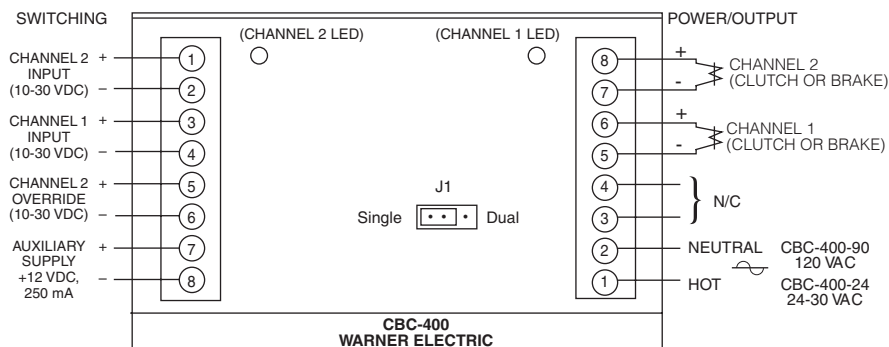

All dimensions nominal unless otherwise specified.

Part No. 6042-101-004

Size 8"H x 6"W x 4"D
(203.2 x 152.4 x 101.6 mm)

Dimensions

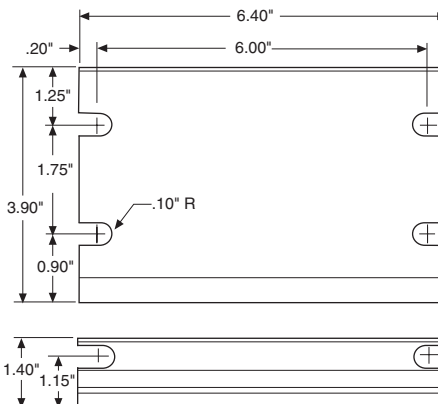

Panel Mounted Control

CBC-450 series Dual channel control with transformer for variable input voltage

The CBC-450 series is a basic on-off control which supplies 24 or 90 VDC for electric clutch/brake operation. They offer optically isolated switching inputs for start, stop, and emergency stop (E-stop). These controls can be set up to operate the two outputs, alternately (single) or simultaneously (dual). Refer to the Appendix for additional setup and switching information. The CBC-450 series has a power transformer which will operate with a 120, 220, 240, 380 or 480 VAC input.

- 24 or 90 Volt DC output
- Auxiliary 12V supply
- Fast coil suppression
- Single or dual channel operation
- Optically isolated switching

Enclosure (Optional)



- Lift off hinge
- Quick-release latches
- Conforms to NEMA Type 13
- European Standard IEC 529, IP65

Part No.	6006-101-007
Size	6"H x 6"W x 6"D (152.4 x 152.4 x 152.4 mm)

Specifications

	CBC-450-90	CBC-450-24
Part No.	6006-448-006	6006-448-005
Input Voltage	120/220/240/380/480 VAC	
Output Voltage	90 VDC	24 VDC
Output Current	1 Amp/Channel 1.2 Amps Total	4 Amps/Channel 4 Amps Total
Auxiliary Supply	12 VDC 250 mA	
Circuit Protection	Fused 1.5 Amp	Fused 5 Amp
Ambient Temperature	+32° to 122°F (0° to 50°C)	
Status Indicators	Red LED indicates channel is energized.	
Adjustments	Jumper for single or dual operation. See Appendix for explanation.	
Inputs	3 Optically isolated, 10-30 VDC, 3-9 mA for Channel 1, Channel 2 and Channel 2 override (E-stop).	

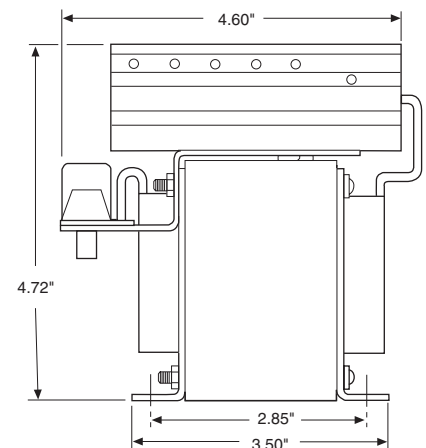
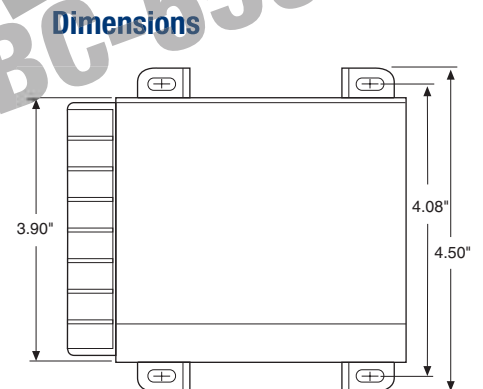

Connection Diagram

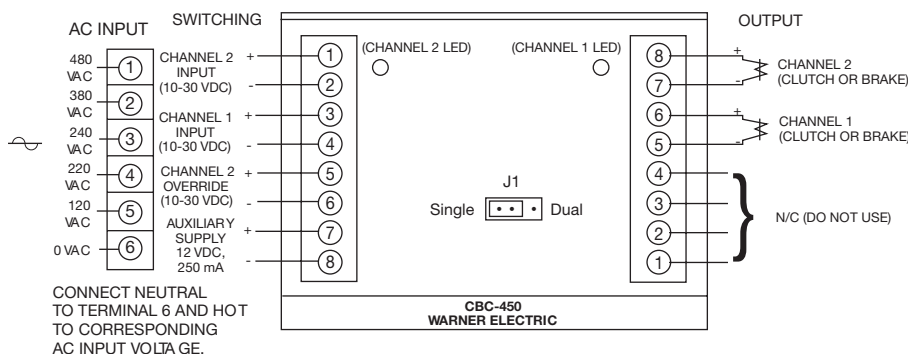

All dimensions nominal unless otherwise specified.

MCS-103-1 Adjustable Torque Controls

Adjustable Torque Control

The MCS-103-1 is an enclosed control complete with a cover and mounting provisions. A brake and clutch may be operated separately with this control – or up to four units, two at a time. The external wiring is connected to the terminal strip located behind the cover.



- Can be used with electrically released brakes

- Torque control for one 90 VDC clutch or brake
- Operates up to four units, two on at a time
- Easy-to-install. Compact. 120 VAC input
- Convenient terminal strip behind an easy-to-remove cover



Dimensions

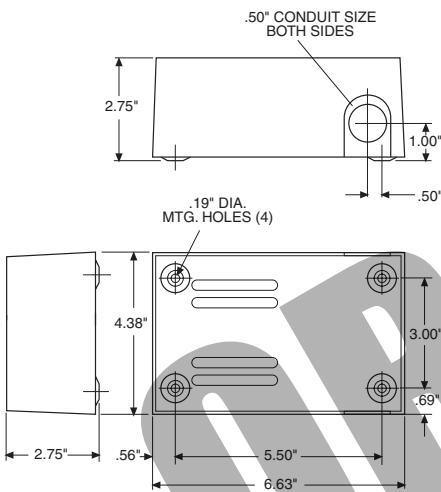

All dimensions nominal unless otherwise specified.

Specifications

MCS-103-1	
Part No.	6010-448-002
Input	120 VAC, 50/60 Hz
Output	1.25 Amp 90 V full wave rectified for one unit and adjustable from 0-90 volts full wave rectified for second unit
Circuit Protection	Fused 1.5 Amp, 250 V
Ambient Temperature	-20° to 113°F (-29° to 45°C)
Maximum Cycle Rate	Limited by the clutch or brake and will vary with application.
Mounting	Mounting centers 5-1/2" wide, 3" high. Knockouts for 1/2" conduit
External Switches (User furnished)	Double pole, double throw maintained contact. Minimum contact rating: 10 Amp, 28 VDC resistive or 10 Amp, 120 VAC inductive. Contact ratings given will operate all Warner Electric brake and clutch units. However, switches with ratings less than those given may be used with fractional horsepower units provided the rating is equal to or greater than the coil current.

Connection Diagrams

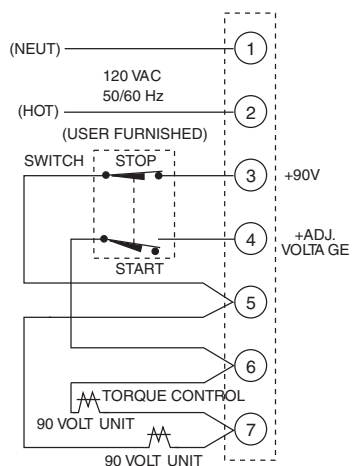

Normal Clutch/Brake Operation
(One unit on at a time)

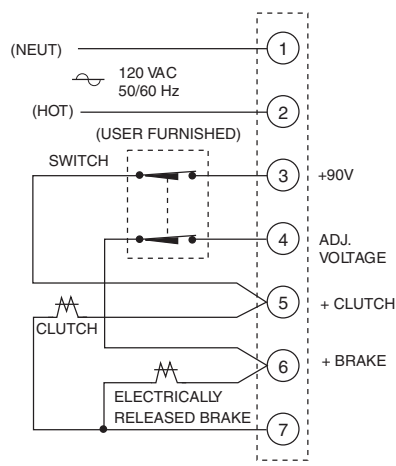

Clutch/Electrically Released
Brake Operation
(Both units on at a time)

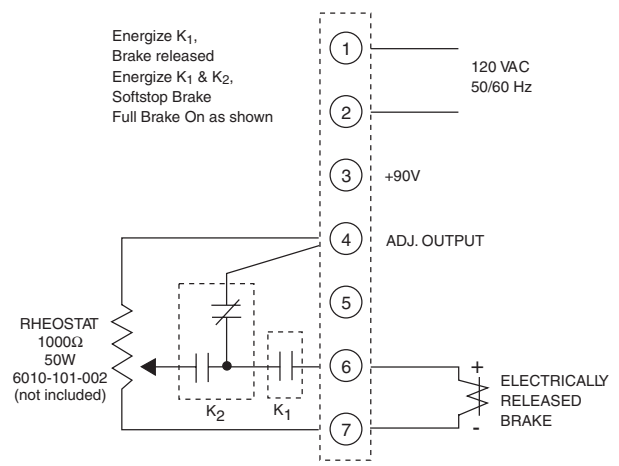

Soft Stop for
Electrically Released Brake

MCS-805-1/MCS-805-2 Power Supply

The DC voltage required to release the Warner Electric ER-1225 Brake is supplied by the MCS-805-1 or MCS-805-2 Power Supply. The correct brake release voltage—approximately 35-75 volts DC—is set by adjusting the power supply at the time of brake installation. Temperature compensating circuits provide proper operation over the entire operating range of 0°F to 150°F. Switching may be provided on either the AC or DC side of the power supply. The MCS-805-1 may be mounted on its back panel or on 1/2" conduit. The MCS-805-2 has a torque adjustment capability for soft stop applications. The MCS-805-2 requires two switching circuits when used for those applications requiring soft engagement.

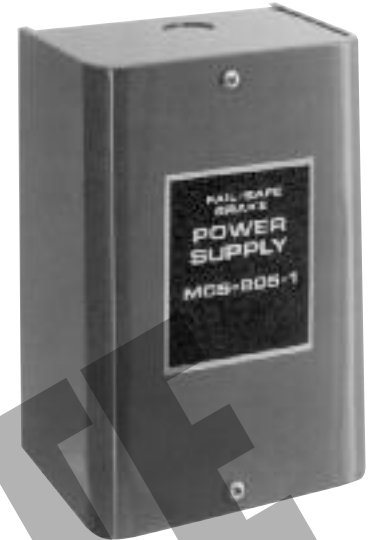

Specifications

	MCS-805-1	MCS-805-2
Part No.	6090-448-006	6090-448-007
Input	115/230 VAC, 50/60 Hz ±10%	115/230 VAC, 50/60 Hz ±10%
Output	0.4 Amp, 35/75 VDC	0.4 Amp, 35/75 VDC
Ambient Temperature	-20° to 150°F (-29° to 65°C)	-20° to 150°F (-29° to 65°C)
Maximum Cycle Rate	Limited by the clutch or brake and will vary with application. Consult factory for specifics.	
External Switches (User furnished)	For DC switching: single pole, single throw. Minimum contact rating 1 amp, 120 volts DC resistive. For AC switching: single pole, single throw. Minimum contact rating 1 amp, 120 volts AC.	
Circuit Protection	.75 Amp 250V Slow Blow 3 AG	

Dimensions

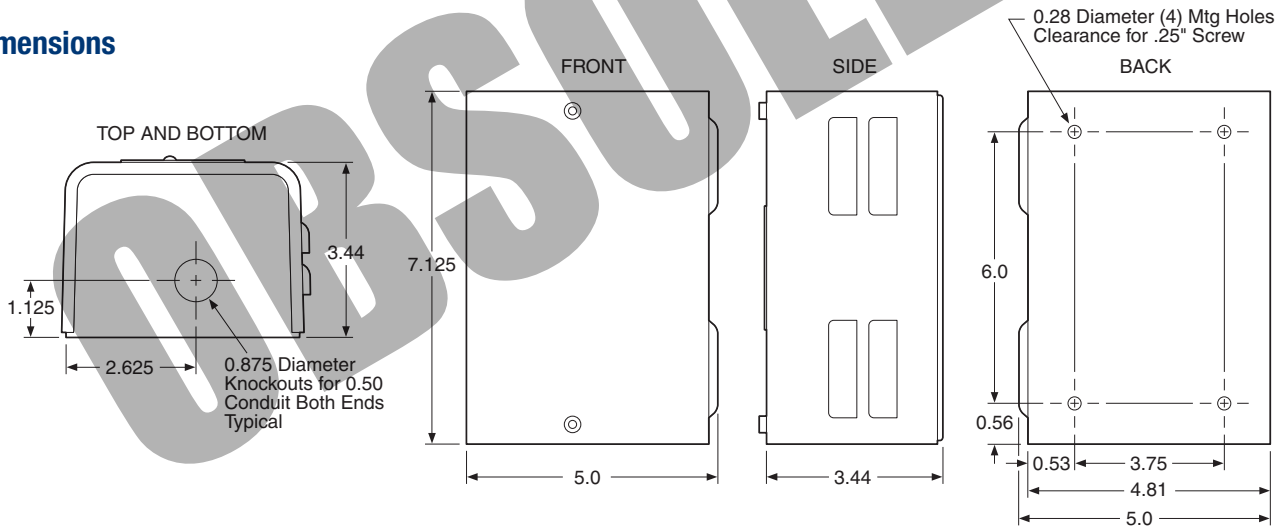

Connection Diagrams

Connect the MCS-805-1 or MCS-805-2 Power Supply per the following diagram and instructions:

MCS 805-1

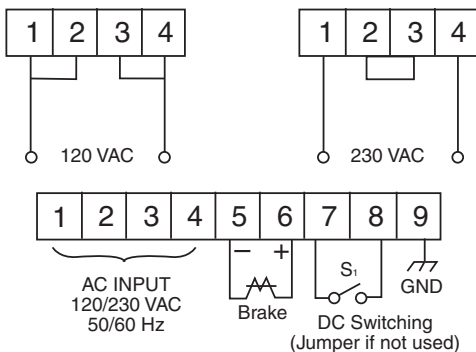

MCS 805-2

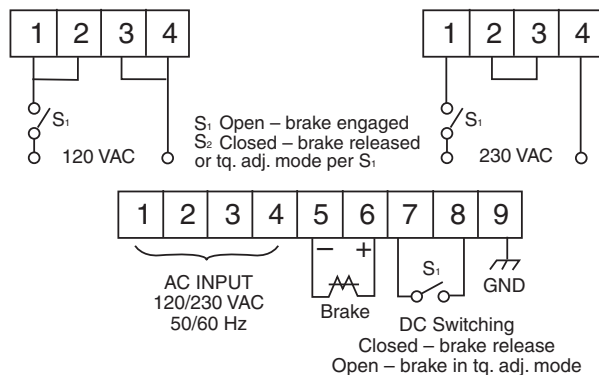

For AC switching, switch may be in series with input supply.
For DC switching, use terminals 7 and 8 as shown.
DO NOT put switch in series with load on terminals 5 and 6.

CBC-200 Adjustable Torque Controls

Single or Dual Channel Adjustable Torque Control

The CBC-200 Series Controls provide single torque control when connected to any of Warner Electric's 90 volt clutches and brakes.

-  US
- Current monitored output maintains consistent torque regardless of variation in coil temperature.
- Switch selection tunes control to exactly match power requirements and operating characteristics of each clutch or brake.
- Individual torque adjust allows preset maximum torque tailored to application requirements.
- Short circuit protection, line to line.
- Torque limiting protects machine components from damage.
- Can be used with electrically released brakes.



CBC-200 Series Dual channel/Single channel torque adjust

The CBC-200 is a dual channel control with one adjustable current and one fixed voltage.

Specifications

CBC-200													
Part No.	6011-448-001												
Input Power	120 VAC +10% -15%, 50/60 Hz, single phase, 215 VA max.												
Output	Pulse-width modulated full wave rectified D.C. Constant current, switch selectable ranges, 0-90 volt												
Ambient Temperature	+32°F to +113°F (0°C to 45°C) with plastic cover installed +32°F to +150°F (0°C to 66°C) with plastic cover removed												
Circuit Protection	Internal line to line short circuit protection Optional customer supplied fusing on A.C. line, 1.5 Amps, 250 VAC. Fast-acting fuse recommended												
Current Adjust (via front panel potentiometers)	Single adjustable channel												
Status indicators	"POWER" – green LED indicates A.C. power is applied to the control. "SHORT" – red LED indicates a short circuit condition exists on one or both outputs.												
Internal Adjustments	Set DIP switches SW1 and SW2 to suit the current draw of the connected connected clutch/brake coil: <table border="1"> <thead> <tr> <th>Switch Range</th> <th>1</th> <th>2</th> <th>3</th> <th>4</th> <th>5</th> </tr> </thead> <tbody> <tr> <td>Max Current Draw (mA)</td> <td>60</td> <td>175</td> <td>245</td> <td>305</td> <td>533</td> </tr> </tbody> </table>	Switch Range	1	2	3	4	5	Max Current Draw (mA)	60	175	245	305	533
Switch Range	1	2	3	4	5								
Max Current Draw (mA)	60	175	245	305	533								
External Switching	Mechanical or electromechanical – customer supplied: 1 Amp, 125 V minimum rating Solid-state, NPN isolated transistor – customer supplied: 2 Amp, J250 V minimum rating. Maximum off state leakage current <1 mA												

Connection Diagram

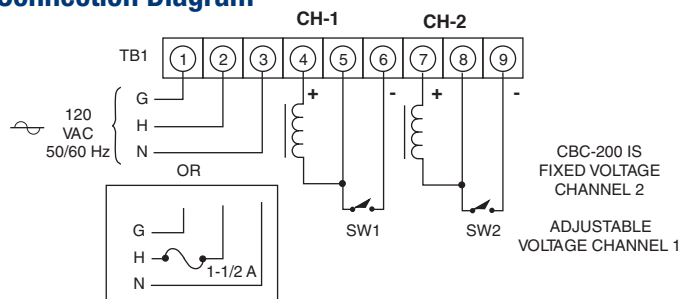

CBC-200 Adjustable Torque Controls

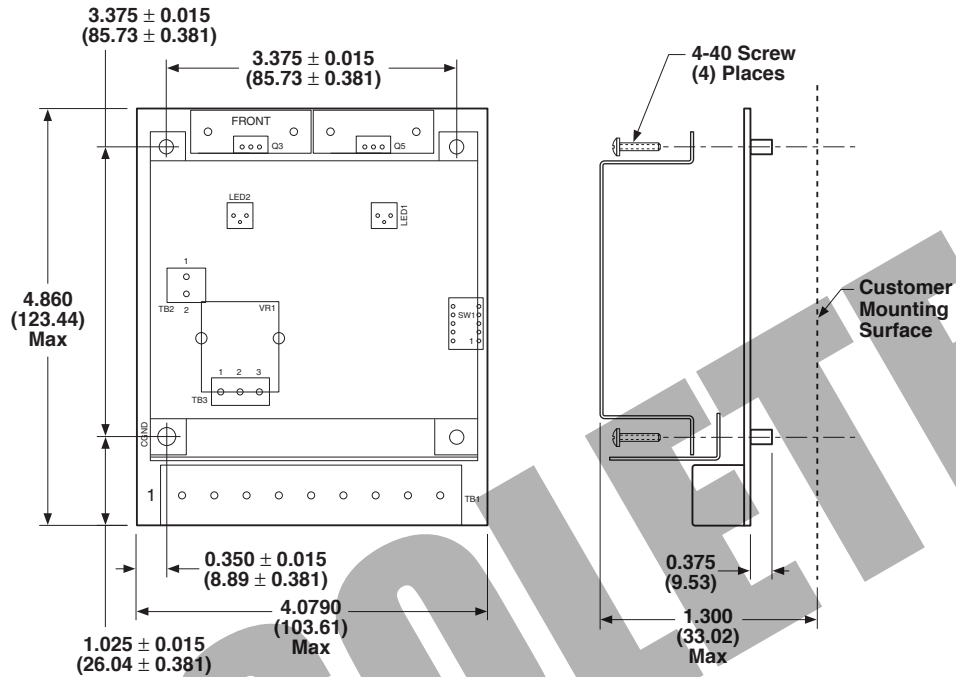

Pots for remote current adjustment: 6011-101-001 single turn
6011-101-002 ten turn

Pots for output level adjustment: 6011-101-003 single turn
6011-101-004 ten turn

Selection Guide

	CBC 200	CBC 200-1	CBC 200-2	CBC 200-3
NEMA 1 Enclosure	6011-448-001	6011-448-002	6011-448-003	6011-448-004
	One channel fixed One channel adjustable	One channel fixed One channel adjustable	One channel fixed One channel adjustable	One channel fixed One channel adjustable
	Adjustable by knob on unit	Adjustable by remote pot	Adjustable by knob on unit	Adjustable by remote pot
	Max. output at 100%	Max. output at 100%	Max. output Adjustable by external pot	Max. output Adjustable by external pot
Chassis Design*	CBC 200-C 6011-448-005	CBC 200-1-C 6011-448-006	CBC 200-2-C 6011-448-007	CBC 200-3-C 6011-448-008

* Provides the same features as the enclosed design in an open chassis mounting.

CBC-300 Adjustable Torque Controls

The CBC-300 Series Controls provide dual torque controls when connected to any of Warner Electric's 90 volt clutches and brakes.

-  UL US
- Current monitored output maintains consistent torque regardless of variation in coil temperature.
- Switch selection tunes control to exactly match power requirements and operating characteristics of each clutch or brake.
- Individual torque adjust allows preset maximum torque tailored to application requirements.
- Short circuit protection, line to line.
- Torque limiting protects machine components from damage.
- Can be used with electrically released brakes.
- Internally Fuse Protected



CBC-300 Series Dual channel/Dual channel torque adjust

The CBC-300 has two adjustable current channels.

Specifications

CBC-300													
Part No.	6021-448-009												
Input Power	120 VAC +10% -15%, 50/60 Hz, single phase, 215 VA max.												
Output	Pulse-width modulated full wave rectified D.C. Constant current, switch selectable ranges, 0-90 volt												
Ambient Temperature	+32°F to +113°F (0°C to 45°C) with plastic cover installed +32°F to +150°F (0°C to 66°C) with plastic cover removed												
Circuit Protection	Internal line to line short circuit protection Optional customer supplied fusing on A.C. line, 1.5 Amps, 250 VAC. Fast-acting fuse internal 300 (recommended 300-1)												
Current Adjust (via front panel potentiometers)	Dual adjustable channels												
Status indicators	"POWER"—green LED indicates A.C. power is applied to the control. "SHORT"—red LED indicates a short circuit condition exists on one or both outputs.												
Internal Adjustments	Set DIP switches SW1 and SW2 to suit the current draw of the connected connected clutch/brake coil: <table border="1"> <thead> <tr> <th>Switch Range</th> <th>1</th> <th>2</th> <th>3</th> <th>4</th> <th>5</th> </tr> </thead> <tbody> <tr> <td>Max Current Draw (mA)</td> <td>60</td> <td>175</td> <td>245</td> <td>305</td> <td>533</td> </tr> </tbody> </table>	Switch Range	1	2	3	4	5	Max Current Draw (mA)	60	175	245	305	533
Switch Range	1	2	3	4	5								
Max Current Draw (mA)	60	175	245	305	533								
External Switching	Mechanical or electromechanical—customer supplied: 1 Amp, 125 V minimum rating Solid-state, NPN isolated transistor—customer supplied: 2 Amp, J250 V minimum rating. Maximum off state leakage current <1 mA												

Connection Diagram

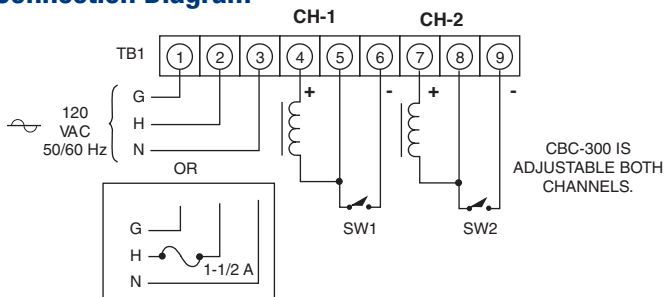

CBC-300 Adjustable Torque Controls

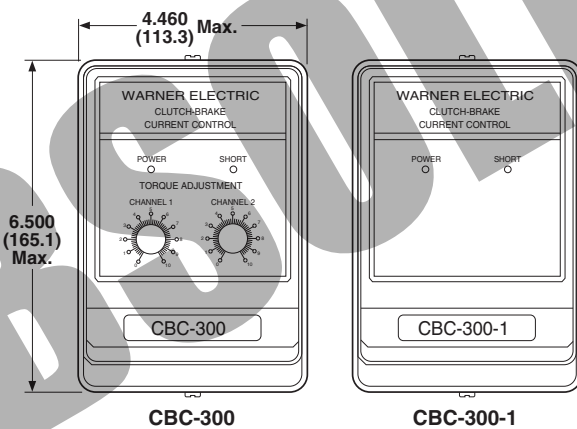
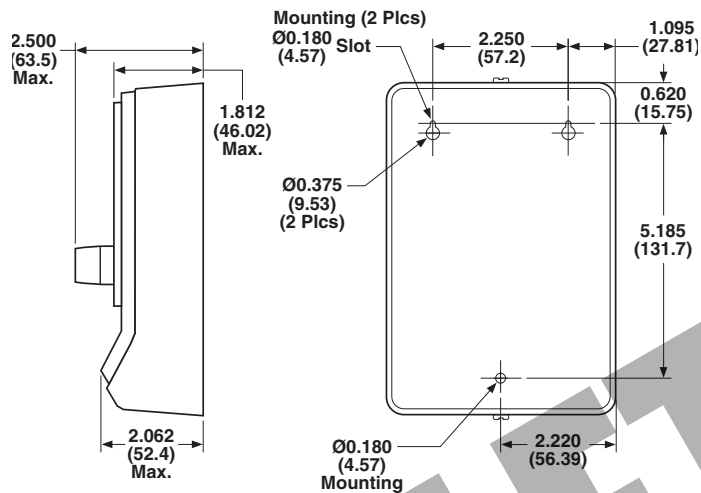

Pots for remote current adjustment: 6011-101-001 single turn
6011-101-002 ten turn

Selection Guide

	CBC 300	CBC 300-1
	6021-448-009	6021-448-002
NEMA 1 Enclosure	Both channels adjustable	Both channels adjustable
	Adjustable by knobs on unit	Adjustable by remote pots
	Max. output at 100%	Max. output at 100%

CBC-500 Adjustable Torque Controls

Panel Mounted



CBC-500 series Dual torque adjustable power supplies

The CBC-500 series is a dual channel adjustable voltage control with optically isolated input switching for 24 and 90 volt electric clutches and brakes. These controls can be set up to energize the two outputs alternately (single) or simultaneously (dual). Refer to the Appendix for additional setup and switching information.

- Dual adjustable channels
- Optically isolated input switching
- Single or dual channel operation
- Auxiliary 12V supply
- Can be used with electrically released brakes

Specifications

	CBC-500-90	CBC-500-24
Part No.	6024-448-003	6024-448-002
Input Voltage	120 VAC	24-30 VAC or VDC
Output Voltage	0-90 VDC	0-24 VDC
Output Current	1 Amp/Channel 2 Amps Total	5 Amps/Channel 5 Amps Total
Auxiliary Supply	12 VDC 250 mA	12 VDC 250 mA
Circuit Protection	Fused 2.5 Amp, 250 V Fast-blo	Fused 6.3 Amp, 250 V Fast-blo
Ambient Temperature	+32° to 122°F (0° to 50°C)	
Status Indicators	Red LED indicates channel is energized.	
Adjustments	Two potentiometers for voltage adjustment of channel 1 and channel 2 output from 0 to full rated voltage. Frequency adjustment from 60 to 400 Hz to reduce clutch/brake "Hum" associated with machine frequencies. Jumper for single or dual operation. See Appendix for explanation.	
Inputs:	3 Optically coupled, 10-30 VDC, 3-9 mA for Channel 1, Channel 2 and Channel 2 override (applies full voltage to channel 1 output)	

Enclosure (Optional)



- Lift off hinge
- Quick-release latches
- Conforms to NEMA Type 13
- European Standard IEC 529, IP65

Connection Diagram

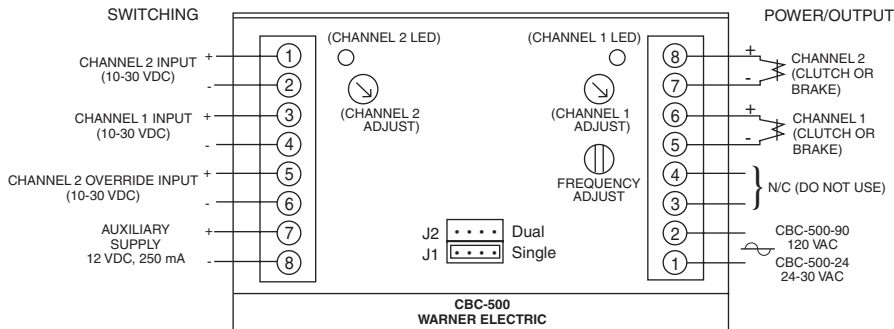

All dimensions nominal unless otherwise specified.

Dimensions

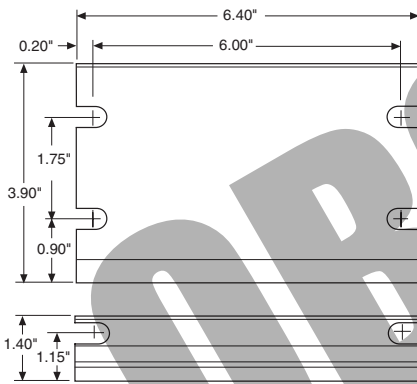

Part No. 6042-101-004

Size 8"H x 6"W x 4"D
(203.2 x 152.4 x 101.6 mm)

CBC-550 Adjustable Torque Controls

Panel Mounted

CBC-550 series Dual adjustable with power transformer

The CBC-550 series is a dual channel adjustable voltage control with optically coupled switching for 24 and 90 volt electric clutches and brakes. These controls can be set up to energize the two outputs alter-nately (single) or simultaneously (dual). Refer to the Appendix for additional setup and switching information.

The CBC-550 series has a power transformer which will operate with a 120, 220, 240, 380, or 480 VAC input.

- Dual adjustable channels
- Optically isolated input switching
- Single or dual channel operation
- Can be used with electrically released brakes



Specifications

	CBC-550-90	CBC-550-24
Part No.	6024-448-006	6024-448-005
Input Voltage	120/220/240/380/480 VAC	
Output Voltage	0-90 VDC	0-24 VDC
Output Current	1 Amp/Channel 1.2 Amps Total	4 Amps/Channel 4 Amps Total
Auxiliary Supply	12 VDC 250 mA	12 VDC 250 mA
Circuit Protection	Fused 1.5 Amp, 250 V fast-blo	Fused 5 Amp, 250 V fast-blo
Ambient Temperature	+32° to 122°F (0° to 50°C)	
Status Indicators	Red LED indicates channel is energized.	
Adjustments	Two potentiometers for voltage adjustment of channel 1 and channel 2 output from 0 to full rated voltage. Frequency adjustment from 60 to 400 Hz to reduce clutch/brake "Hum" associated with machine frequencies. Jumper for single or dual operation. See Appendix for explanation.	
Inputs	3 Optically coupled, 10-30 VDC, 3-9 mA for Channel 1, Channel 2 and Channel 2 override (applies full voltage to channel 1 output)	

Enclosure (Optional)



- Lift off hinge
- Quick-release latches
- Conforms to NEMA Type 13
- European Standard IEC 529, IP65

Part No.	6006-101-007
Size	6"H x 6"W x 6"D (152.4 x 152.4 x 152.4 mm)

CBC-550 Adjustable Torque Controls

Panel Mounted

Dimensions

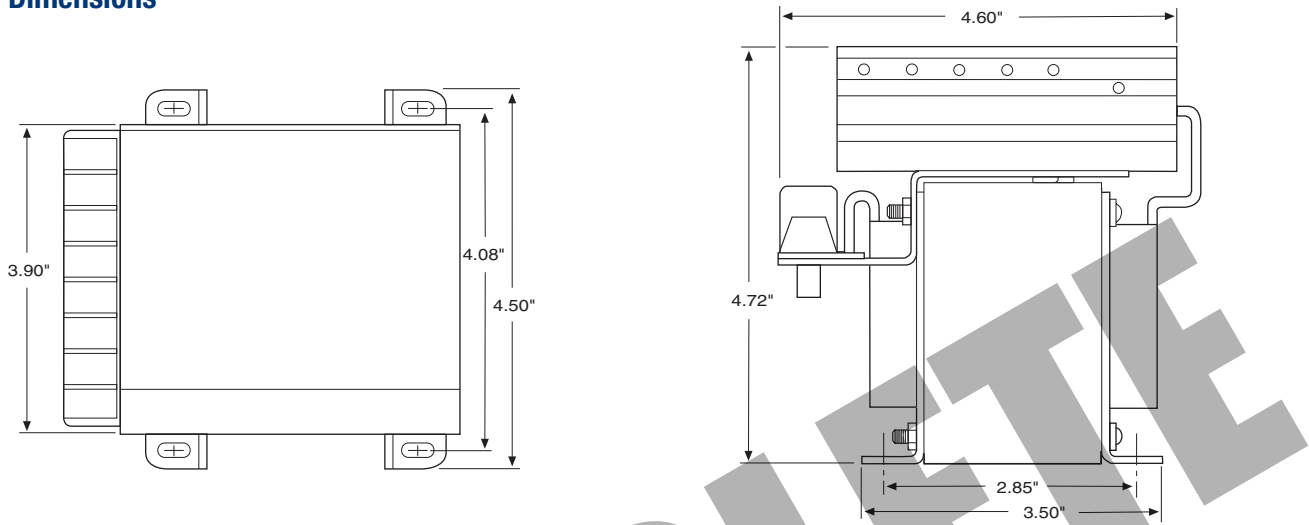

Connection Diagram

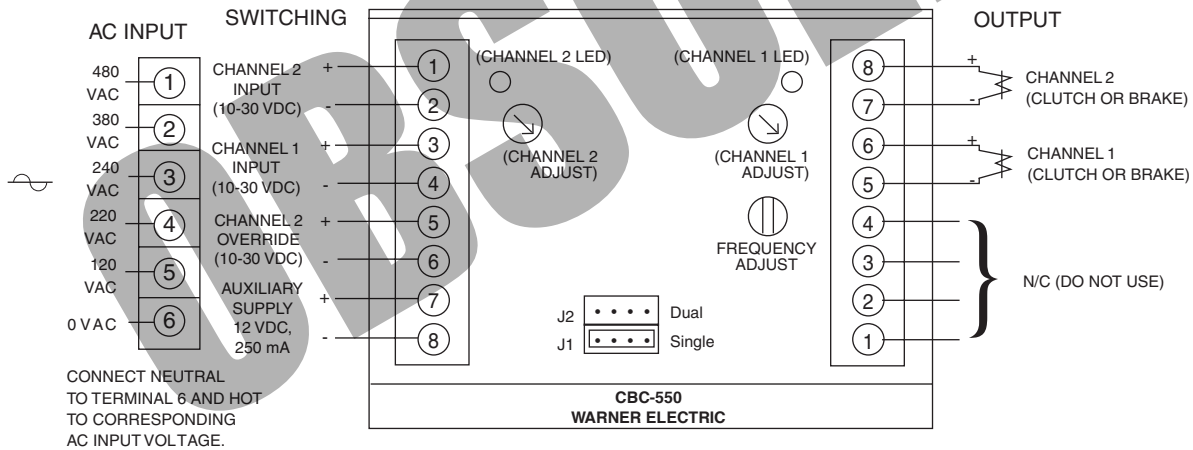

All dimensions nominal unless otherwise specified.

CBC-1825R Adjustable Torque Controls

Panel Mounted

CBC-1825R series

The CBC-1825R is designed to provide consistent and repeatable acceleration and deceleration when used with Warner Electric 90 VDC clutches and brakes. Current to each channel is introduced along an adjustable time ramp and monitored continuously. Adjustments include initial pull-in pulse, hold level, maximum torque, and ramp time. LEDs are provided on the circuit board to indicate power is applied to the clutch or brake unit.

Note: It is recommended that the auto-gap springs be removed from the clutch and brake for successful accel-decel application.

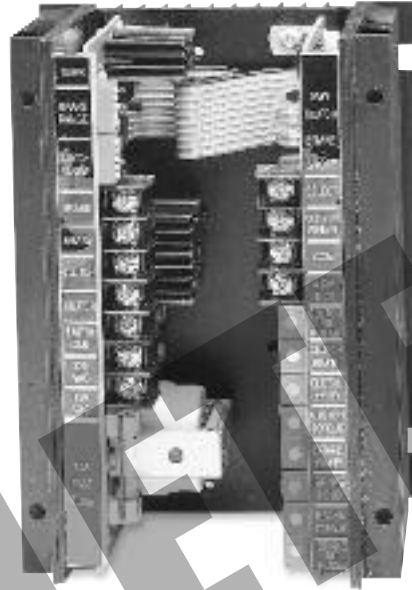

Specifications

CBC-1825R	
Part No.	1825-448-001
Input Voltage	120 VAC, 50/60 Hz, 100 VA maximum
Output Current	Current driven PWM, compatible with 90 VDC clutch/brake (switch selectable current output)
Auxiliary Supply	12 VDC 250 mA
Circuit Protection	Input Fused 1.5 Amp, 250 V fast-blo clutch and brake outputs are short circuit protected
Status Indicators	Clutch and brake LEDs indicate output is energized Short circuit LED indicates a fault
Ambient Temperature	0° to 122°F (-18° to 50°C)
Switching	Contact rating: 15 mA @ 15 V, open collector NPN 2mA maximum allowable leakage current and 2 V maximum saturation voltage

Set-up

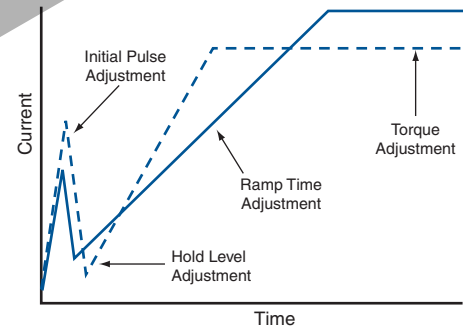

All dimensions nominal unless otherwise specified.

CBC-1825R Adjustable Torque Controls

Panel Mounted

Dimensions

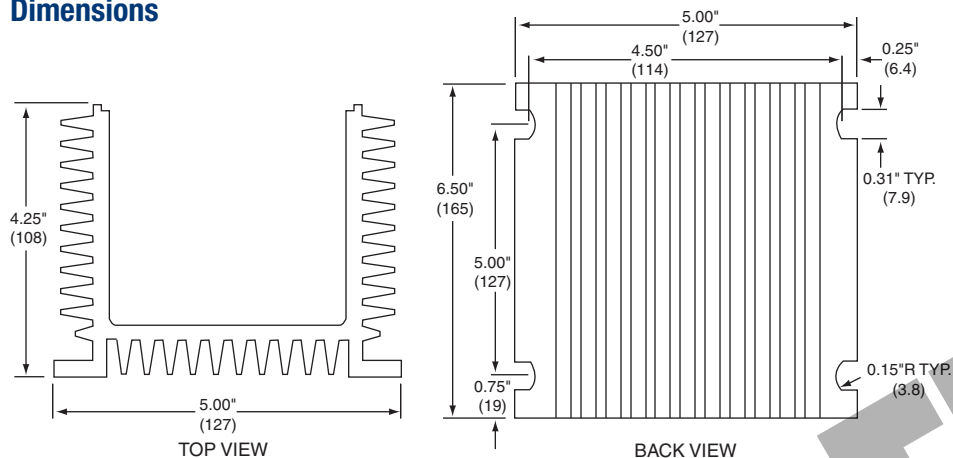

Connection Diagram

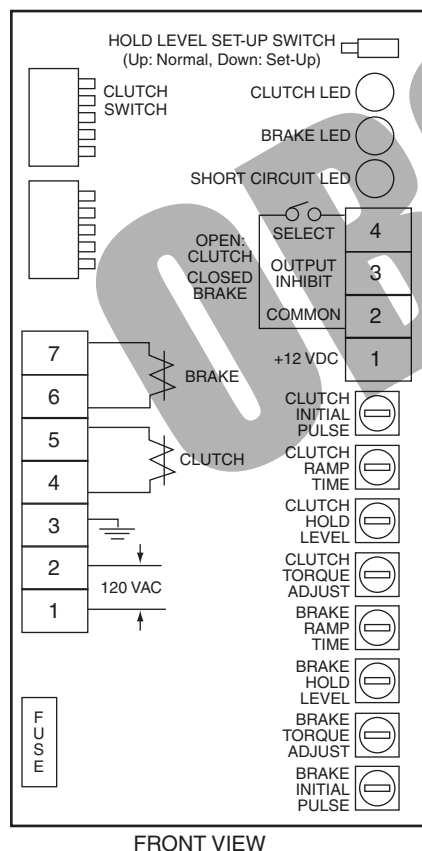

CBC-700 Overexcitation Controls

General Purpose OEX Control

CBC-700 Series

Simple, compact, high performance OEX control for either 90 or 24 VDC clutches and brakes. OEX spike duration and anti-overlap times delay are adjustable. Two optically isolated inputs.

- High performance
- Switch selectable OEX duration
- Force decay suppression with adjustable anti-overlap time delay
- Compact, flexible mounting
- Models for 24 or 90 volt clutches and brakes
- Cycle rate limited by clutch/brake



Specifications

	CBC-700-90	CBC-700-24
Part No.	6042-448-003	6042-448-002
Input	120 VAC, 50/60 Hz	24-28 VAC, 50/60 Hz
Output Voltages		
Steady State	90 VDC	24 VDC
Overexcitation	340 VDC	105 VDC
Output Current (Per channel alternately)	.5 Amps	3.5 Amps
OEX Pulse Duration	Adjustable through logic board dip switches (see service manual)	
Inputs	Two-optically isolated (10-30 VDC)	
Ambient Temperature Range	0°F to 140°F (-18°C to +60°C)	
Maximum Off State Leakage	<2 mA (inputs)	
Circuit Protection	2.5A Slo-Blo (5 x 20 mm)	5A Slo-Blo (5 x 20 mm)
Auxiliary Supply	12 VDC, 250 mA maximum	

Enclosure (Optional)



- Lift off hinge
- Quick-release latches
- Conforms to NEMA Type 13
- European Standard IEC 529, IP65

Part No.	6042-101-004
Size	8"H x 6"W x 4"D (203.2 x 152.4 x 101.6 mm)

CBC-700 Overexcitation Controls

General Purpose OEX Control

Dimensions

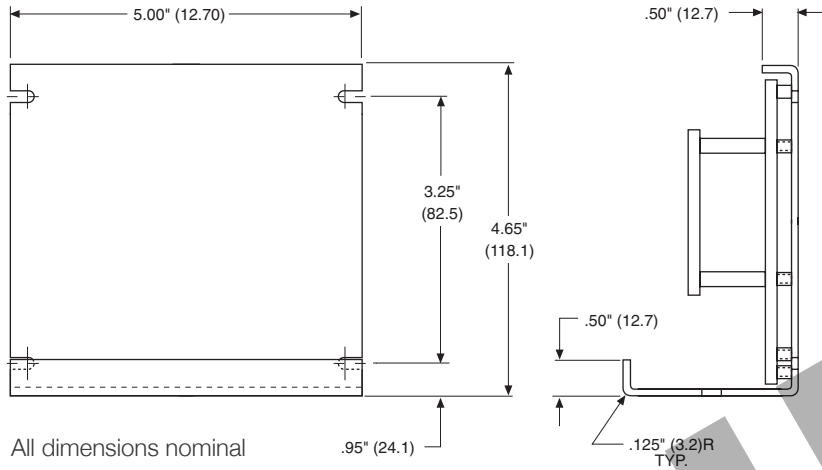

All dimensions nominal unless otherwise specified.

Connection Diagram

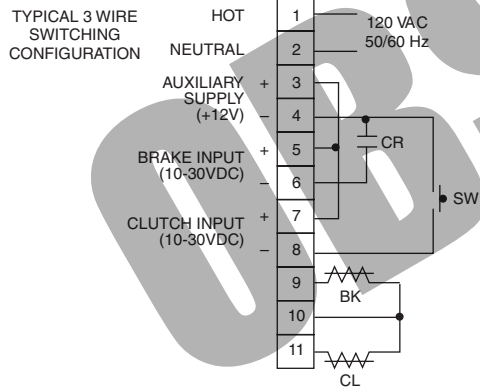

NOTE: CR, SW user furnished switch options for use with control.
CR normally open relay contact
SW normally open push button switch

CBC-750 Overexcitation Control

Rapid Acceleration/Deceleration

CBC-750 Dual channel, current based OEX with switching logic

Warner Electric's CBC-750 Constant Current Overexcitation Clutch/Brake Control is a solid-state electronic control designed to increase the cycle rate capabilities and accuracies of electromagnetic clutches and brakes. The control accomplish this by sending a momentary high voltage overexcitation spike to the clutch and/or brake magnetic coil to build a high density magnetic flux field almost instantaneously. By using overexcitation, the response time is reduced as dramatically as performance is increased. For example, the current build up time of a 5 inch, 6 volt magnet is reduced from 84 milliseconds to 2 milliseconds.

The CBC-750 user selects either 120, 220 or 240 VAC operation at the time of installation, and is available for 6 volt clutches and brakes.

LED indicators on the faceplate of each control tell the user the status of input signals, output activation and any auxiliary inputs. A reset switch resets the output should a short be detected. Remote torque adjust potentiometer inputs are also provided. Appropriate current range for each size clutch or brake is selected by a dip switch. Constant current for each level is assured by the control's design.

- Maintains torque at preset levels regardless of temperature variations
- Automatically controls OEX pulse duration for optimum response without overheating coils
- Automatically prevents clutch and brake "overlap"
- Configurable as an analog follower control through remote top input
- Integral switching logic through auxiliary, inhibit and override inputs



Shown with optional cover, part number 6041-101-004

- High performance OEX control
- Constant current output capability
- Available for 6 volt clutches and brakes
- Outputs short circuit protected.
- AC/DC optically isolated inputs
- Transformer isolation Remote torque potentiometer capability
- Input/Output inhibit functions
- Switch selectable OEX function
- Automatic CH1/CH2 anti-overlap feature
- Heavy duty suppression circuits
- Selectable output current ranges
- Remote status indicators inputs and outputs

Specifications

CBC-750-6	
Part No.	6041-448-001
Input Power	120/220/240 VAC, $\pm 10\%$, 50/60 Hz, 350 VA (switch selectable)
Control Inputs	Opto-isolated 10-30 VDC @ 10-35 mA nominal sinking or sourcing, or 24 VAC (50/60Hz) @ 22 mA nominal, or 120 VAC (50/60 Hz) @ 20 mA nominal
Clutch/brake Output	
Steady State Output	
Current controlled	.910 to 4.34 A max.
Current Rise Time	Dependent on clutch/brake size
Current Fall Time	Depending on clutch/brake size
Overexcitation Voltage	75 VDC nom.
Overexcitation Time	Automatic adjustment by control feedback
Anti-overlap Time	Automatic adjustment by control feedback
Power Supply Output	12 VDC, ± 0.6 VDC, 250 mA max.
Auxiliary Indicator Outputs	Opto-isolated NPN transistors 24 VDC maximum, 20 mA max., reverse polarity protected
Circuit Protection	Internal short circuit protection on each output channel.
Fusing	
AC Input Line	2 Amp, 250 V Slo-Blo
OEX Supply	10 Amp, 32 V Slo-Blo

CBC-750 Overexcitation Controls

Rapid Acceleration/Deceleration

Seven optically isolated inputs accept 10-30V A.C./D.C. (TB2) or 120 VAC (TB3), configured through set-up switches

1. Channel 2 Input
2. Channel 2 Input Inhibit (disregards channel 2 input signal)
3. Auxiliary Input
4. Channel 1 Input
5. Channel 1 Input Inhibit (disregards channel 1 input signal)
6. Output Inhibit (deactivates both output channels)
7. Channel 2 Override (applies full voltage to channel 1 output)

Connection Diagram

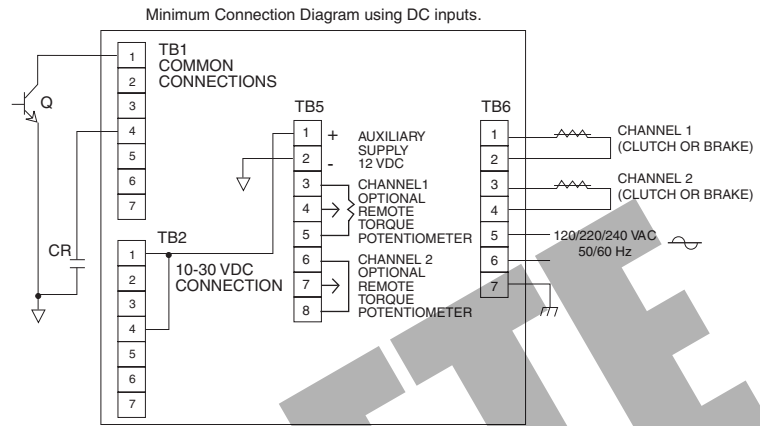

NOTE: Q, CR user furnished switch options for use with control.
Q NPN transistor
CR normally open relay contact

Dimensions

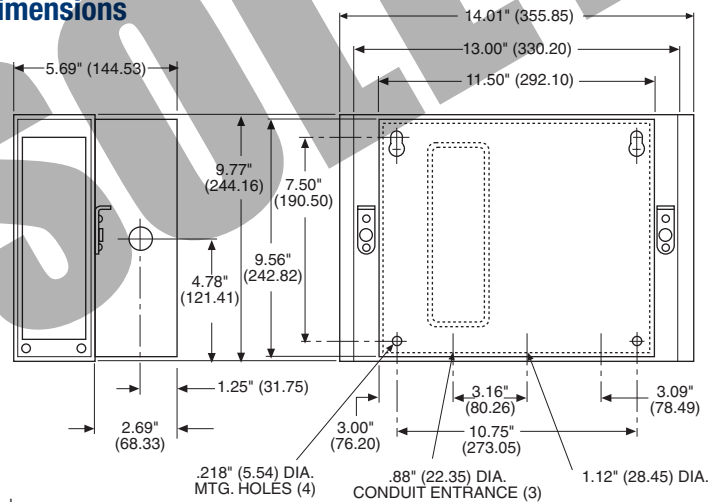

All dimensions nominal unless otherwise specified.

Setup Switches

SW1: AC Voltage selection switch on terminal board inside control unit

Max. Current Output

(SW7 & SW8 settings)

Nominal Voltage	1	2	3	4	5
6	0.910	2.35	3.183	3.760	4.340

SW8

Channel 2 current range selector (settings in diagram below)

SW7

Channel 1 current range selector (settings in diagram below)

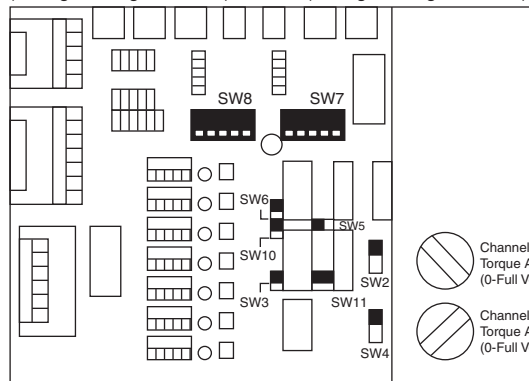

SW6

Channel 2 OEX enable (✓) / disable (✗)

SW5

Channel 1 OEX enable (✓) / disable (✗)

SW10

Channel 1 input invert (✓) / (✗)

SW2

Channel 1 local (✓) or remote (✗) torque adjust

SW3

Level/pulse selector level (✓) pulse (✗)

SW4

Channel 2 local (✓) or remote (✗) torque adjust

SW11

Auxiliary input selector Channel 1 (✓) Channel 2 (✗)

All switches are in the down (✓) position from factory

Appendix

CBC-500/550

Single vs. Dual Operation

The CBC-500/550 series controls allow operation in either a single or dual mode. The mode of operation is determined via the position of a jumper on the main control board.

The controls are shipped with the jumper in the J1 or single mode position. A variety of output logic can be accomplished via the single/dual jumper position and whether the control is wired to one input switching device (2-wire mode) or two input switching devices (3-wire mode). The following diagrams show how each channel (output) of the control can be either alternately or simultaneously energized.

2-wire Switching Option

Control's switching terminal block

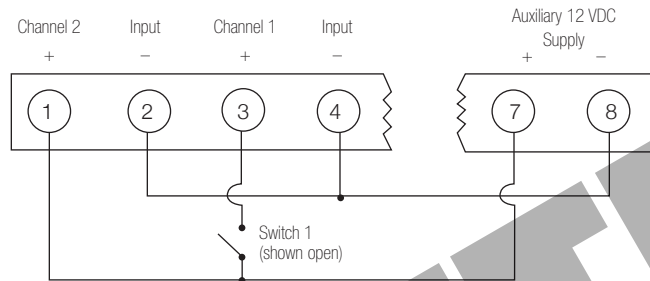

Jumper Mode	Switch 1	Channel 1	Channel 2
J1-Single	Open	Off	Powered
	Closed	Powered	Off
J2-Dual	Open	Powered	Powered
	Closed	Off	Off

CBC-500/550

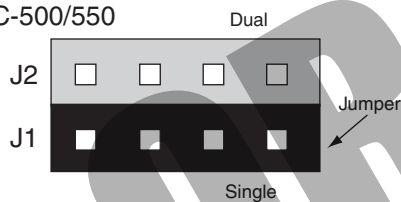

3-wire Switching Option

Control's switching terminal block

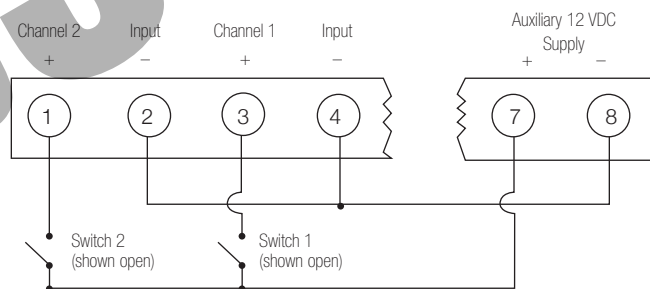

Jumper Mode	Switch 1	Switch 2	Channel 1	Channel 2
J1-Single	Closed	Open	Latched On	Off
	Open	Closed	Off	Latched On
J2-Dual	Closed	Open	Off	Off
	Open	Closed	Latched On	Latched On

1. What transformers can be used with controls requiring 24-30 VAC input?

Manufacturer	Part Number	Primary	Secondary
Abbott	6B 12-160	115 VAC	24V @ 6 amps
Quality	6-K-119VBR	115/230 VAC	24V @ 8 amps
Signal	24-6	115 VAC	24V @ 6 amps
Signal	DP24-6	115/230 VAC	24V @ 6 amps
Triad	F-260-U	115 VAC	24V @ 6 amps

2. What is the difference between a MCS-801 and a CBC-801-1 or between a MCS-103 and a MCS-103-1?

There is no performance difference between the MCS-103 and MCS-103-1. There is no performance difference between the MCS-801 and CBC-801-1. The CBC-801-1 is roughly 1/4" shorter than the MCS-801. The units wire and work exactly the same.

3. Which power supplies can be used with the SF 1525HT and SFC 1525HT coil?

The SF and SFC 1525 High Torque clutch coils require .794 amps of current to provide full rated torque. The following power supplies and controls will provide the needed power.

CBC-100	.8 amps	MCS-103-1	1.25 amps
CBC-150	.8 amps	CBC-500	1 amp
CBC-801	1.25 amps	CBC-550	1 amp
CBC-400	1 amp		

4. Can I use a CBC-160 with a variable frequency drive and AC motor?

No. As the voltage to the drive is varied, the output to the electrically released brake would also vary. This would cause the brake to re-engage when it should be released.

5. Which power supplies offer a 12 VDC power source that could be used to power auxiliary switch inputs such as inductive or photoelectric sensors?

CBC-500, CBC-550, CBC-700, CBC-750

6. We plan to use a PLC in the application. Does that impact our choice of control or power supply?

The CBC-801s and MCS-103-1 are not very PLC friendly. Both require a 10 amp relay for switching which is not very common for PLCs. Alternatives would be CBC-150 or CBC-500/550 respectively which are more 'PLC-Friendly'.

7. Which of the controls would allow for the independent operation of two clutches or two brakes?

Four controls allow for completely independent operation of two clutches or brakes. That is, that a clutch and brake can both be on at once, both off at once, or one on and one off. These controls are:

CBC-801-1 and CBC-801-2, MCS-103-1, CBC-300

The CBC-500/550 allows for operation of both channels on at once, both channels off at once or cycling between channel one and two. However, in the both-on/both-off mode, you cannot also do independent single channel operation.

8. Our PLC can provide 24 or 90 volts output. Why do we need a separate power supply at all?

There are two reasons to use a Warner Electric control or power supply with clutches and brakes. First, the electric coil within clutches and brakes can create a significant back EMF spike when turned off. This can damage PLC circuits (some PLCs include a diode for protection). All Warner Electric controls and power supplies include a suppression network to protect upstream electrical components from the back EMF spike. Second, this same suppression network will speed the collapse of the magnetic field within a clutch or brake. Without the suppression circuit, a clutch and brake will often overlap each other in performance with resulting poor machine performance.

9. Which controls can be used with electrically released brakes?

The CBC-160-1 and CBC-160-2 are designed specifically to use with the conduit box of EM and EUM electrically released brake designs. The CBC-160-1 and CBC-160-2 can also be used with ER and FB brake designs.

The MCS-103-1, CBC-300 and CBC-500/550 can all be used with ER, FB as well as UM-FBC, EM and EUM-FBB and EM and EUM-MBFB designs.

The MCS 805-1 and MCS 805-2 are for use only with the ER 1225 brakes. The ERS series brakes can be used with the CBC-100 or CBC-801 power supplies.

Ordering Information

Model	Part Number	Page
CBC-100-1	6003-448-101	204
CBC-100-2	6003-448-103	204
MCS-103-1	6010-448-002	210
CBC-150-1	6004-448-001	204
CBC-150-2	6004-448-002	204
CBC-160-1	6013-448-001	205
CBC-160-2	6013-448-002	205
CBC-200	6011-448-001	212, 213
CBC-200-1	6011-448-002	213
CBC-200-2	6011-448-003	213
CBC-200-3	6011-448-004	213
CBC-300	6021-448-009	214, 215
CBC-300-1	6021-448-002	215
CBC-300-2	6021-448-003	215
CBC-300-3	6021-448-004	215
CBC-400-24	6006-448-002	208
CBC-400-90	6006-448-003	208
CBC-450-24	6006-448-005	209
CBC-450-90	6006-448-006	209
CBC-500-24	6024-448-002	216
CBC-500-90	6024-448-003	216
CBC-550-24	6024-448-005	218
CBC-550-90	6024-448-006	218
CBC-1825R	1825-448-001	220
CBC-700-24	6042-448-002	222
CBC-700-90	6042-448-003	222
CBC-750-6	6041-448-001	224
CBC-750-24	6041-448-002	224
CBC-750-90	6041-448-003	224
CBC-801-1	6001-448-004	206
CBC-801-2	6001-448-006	206
CBC-200-C	6011-448-005	213
CBC-200-1-C	6011-448-006	213
CBC-200-2-C	6011-448-007	213
CBC-200-3-C	6011-448-008	213
CBC-300-C	6021-448-005	215
CBC-300-1-C	6021-448-006	215
CBC-300-2-C	6021-448-007	215
CBC-300-3-C	6021-448-008	215
Octal Socket, Foot Mount	6001-101-001	206, 207
Octal Socket, DIN Rail Mount	6001-101-002	206, 207
CBC-802	6002-448-002	207
Optional Enclosure: CBC-400, CBC-500, CBC-700	6042-101-004	208, 217, 222
Optional Enclosure CBC-450, CBC-550	6006-101-007	209, 218
MCS-805-1	6090-448-006	211
MCS-805-2	6090-448-007	211

OBSOLETE

Packaged Performance Products Service Parts

Contents

C-face Compatible Units

Original design and Gen 2 Service Parts information are included on these pages.

UniModules

UM Series Clutch and Clutch/Brake Combinations	232
UM-C Series Ceramic Faced Clutch/Brakes	N/A
Smooth-Start Clutch/Brakes	268

Electro Modules

EM Series Modular Clutches, Brakes and Motor Brakes	248
---	-----

Enclosed UniModules

EUM Series Clutch and Clutch/Brake Combinations	262
EUM-W Series Washdown Clutch/Brakes	262

Shaft and Base Mounted Units

Electro Clutches and Brakes

EC Series Shaft Mounted Clutches	270
EB Series Shaft Mounted Brakes	276

Advanced Technology Clutches and Brakes

ATC Series Clutches	282
ATB Series Brakes	284

Packaged Stationary Field Clutches

SFP Clutches	N/A
------------------------	-----

Electro Pack

EP Series Base Mounted Clutch/Brakes	286
EP-C Series Ceramic Faced Base Mounted Clutch/Brakes	N/A
**EP-W Electro Pack Washdown Clutch/Brakes	N/A

Electrically Released Brakes

Spring-Set Brakes

ERS Series Static Engaged Brakes	N/A
ERD Series Dual Purpose Engagement Brakes	N/A
UNIBRAKES AC Motor Brakes	298

*Permanent Magnet Brakes

FB Series Shaft Mounted Brakes	294
ER Series Flange Mounted Brakes	296

*EM

UM-FBC Series Clutch/Electrically Released Brakes	N/A
EM-FBB, EM-FBC, EM-MBFB Series Brake Modules	N/A

* It is recommended that electrically released brakes such as the EM-FBB, UM-FBC and EM or EM-MBFB not be rebuilt in the field. Specific custom-fixtures are used during factory assembly that ensure proper alignment of internal components and therefore unit function. These brakes are commonly used in applications involving personnel or equipment safety and an incorrectly rebuilt brake might result in danger to personnel or damage to expensive equipment. Therefore, replacement components are not available for these products.

** It is not possible to rebuild an EP-W unit without damage to the unit coating. Damaging the coating will leave the unit prone to water damage and/or provide access for bacteria. Therefore, replacement components for these products are not available.

When replacing components in clutches and brakes several guidelines are appropriate. In all cases, when replacing worn friction surfaces both the components need to be replaced. In many cases, the splined hubs should be inspected and replaced if worn.

Common Replacement Practices:

EM/UM/EUM clutches

- Replace rotor and armature
- Inspect splined hub

EM/UM/EUM clutch/brakes

- Replace clutch rotor and armature
- Replace brake magnet and armature
- Inspect splined hub

EC clutches

- Replace clutch rotor and armature

EB brakes

- Replace magnet and armature

ATC clutches

- Replace clutch rotor facing and armature facing
- Inspect splined hub

ATB brakes

- Replace magnet facing and armature facing
- Inspect splined hub

Electro-Pack clutch/brake

- Replace clutch rotor and armature
- Replace brake magnet and armature
- Inspect splined hub

Electrically released brakes

- On all Electrically released brakes the magnet and armature are only sold as a matched set and must be replaced as a set.

A note on burnishing:

When new friction surfaces are installed it will be necessary to burnish the unit prior to returning to full production rates. Burnishing is the act of wearing in the friction faces to ensure full engagement and therefore full torque. Burnishing is achieved by simply cycling the unit under less than full load (machine empty, if possible). Most units will achieve full torque in less than 100 cycles. Refer to the service manual for more details.

UM Series UniModule

GEN 2 Design – UM-1020 Clutch/Brake Combination

Sizes 50, 100 and 180

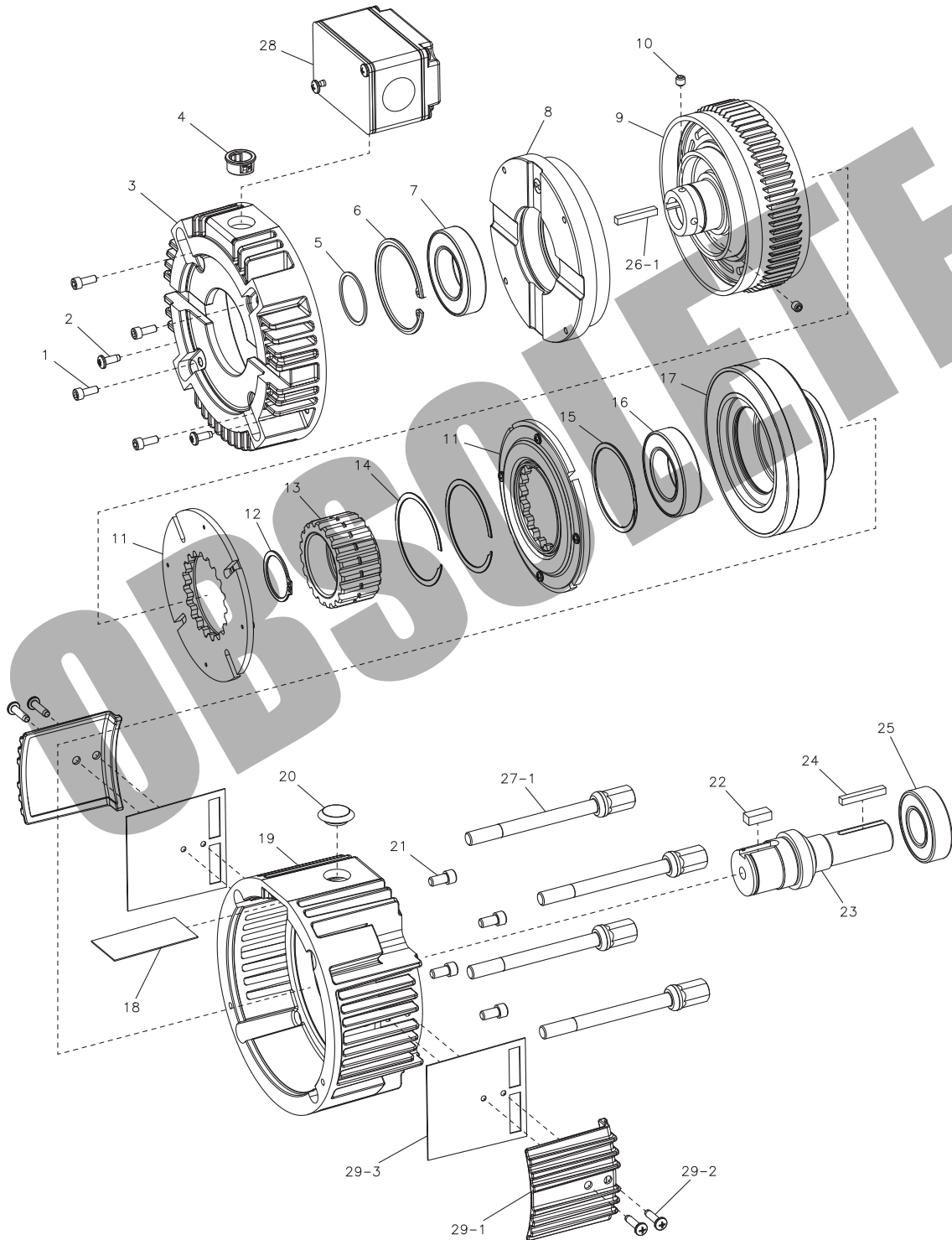

Service Parts

GEN 2 Design – UM-1020 Clutch/Brake Combination Sizes 50, 100 and 180

Component Parts

Item	Description	UM-50		UM-100		UM-180	
		Part No.	Qty.	Part No.	Qty.	Part No.	Qty.
1	Field Mounting Screw	797-1214	4	797-1214	4	797-1214	4
2	Screw	797-1568	2	797-1568	2	797-1568	2
3	Housing	535-0204	1	535-0204	1	535-0204	1
4	Bushing	572-0522	1	572-0522	1	572-0522	1
5	Retaining Ring	748-0018	1	748-0018	1	748-0018	1
6	Retaining Ring	748-0561	1	748-0561	1	748-0561	1
7	Ball Bearing	166-0150	1	166-0150	1	166-0150	1
8	Field Assembly		1		1		1
	6 Volt	5370-451-201		5370-451-206		5370-451-206	
	24 Volt	5370-451-203		5370-451-208		5370-451-208	
	90 Volt	5370-451-204		5370-451-209		5370-451-209	
9	Rotor Assembly	5370-751-019	1	5370-751-049	1	5370-751-051	1
10	Set Screw	797-1098	2	797-0069	2	797-0069	2
11	Armature Assembly	5370-111-022	2	5370-111-013	2	5370-111-013	2
12	Retaining Ring	748-0445	1	748-0676	1	748-0676	1
13	Armature Hub	540-1638	1	540-2038	1	540-2038	1
14	Armature Hub Retaining Ring			748-0450	2	748-0450	2
15	Retaining Ring	748-2044	1	748-0101	1	748-0101	1
16	Ball Bearing	166-0143	1	166-0150	1	166-0150	1
17	Magnet Assembly		1		1		1
	6 Volt	5370-631-201		5370-631-216		5370-631-216	
	24 Volt	5370-631-203		5370-631-218		5370-631-218	
	90 Volt	5370-631-204		5370-631-219		5370-631-219	
18	Insulator	572-1029	1	572-1029	1	572-1029	1
19	Housing	535-0206	1	535-0206	1	535-0206	1
20	Plug	680-0037	1	680-0037	1	680-0037	1
21	Magnet Mounting Screw	797-0077	4	797-1358	4	797-1358	4
22	Key	590-0043	1	590-0084	1	590-0084	1
23	Shaft	798-0298	1	798-0301	1	798-0304	1
24	Key	590-0029	1	590-0029	1	590-0029	1
25	Ball Bearing	166-0143	1	166-0143	1	166-0143	1
26	Mounting Accessory	5370-101-072	1	5370-101-072	1	5370-101-072	1
	26-1 Key	590-0142	1	590-0142	1	590-0142	1
27	Mounting Accessory	5370-101-075	1	5370-101-075	1	5370-101-075	1
	27-1 Tie Bolt	825-0014	4	825-0014	4	825-0014	4
28	Conduit Box (Optional)	5370-101-042	1	5370-101-042	1	5370-101-042	1
29	Cover Kit (Optional)	5370-101-076	1	5370-101-076	1	5370-101-076	1
	29-1 Cover	258-1227	2	258-1227	2	258-1227	2
	29-2 Screw	797-1562	4	797-1562	4	797-1562	4
	29-3 Gasket	495-0042	2	495-0042	2	495-0042	2

Refer to service manual P-273-4.

These units meet the standards of UL 508 and are listed under guide card #NMTR2, file #59164.



Service Parts

UM Series UniModule

Original Design – UM-1020 Clutch/Brake Combination

Sizes 50, 100, 180, 210 and 215

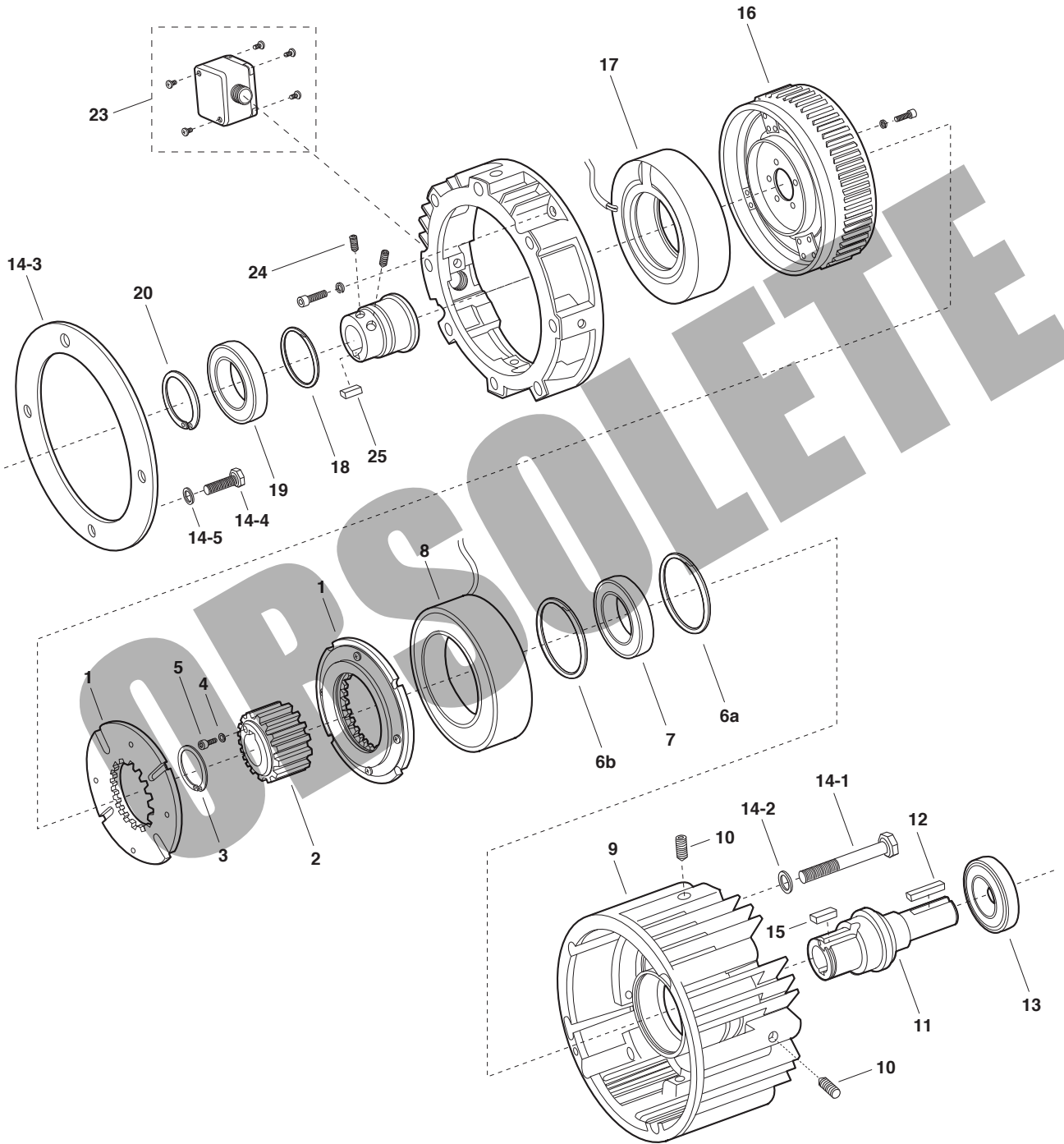

Service Parts

Original Design – UM-1020 Clutch/Brake Combination Sizes 50, 100, 180, 210 and 215

Component Parts (Gray shaded areas indicate original design parts which will be available for a limited time)

Item	Description	UM-50		UM-100		UM-180		UM-210		UM-215	
		Part No.	Qty.	Part No.	Qty.	Part No.	Qty.	Part No.	Qty.	Part No.	Qty.
1	Armature Assembly	5370-111-011	2	5370-111-013	2	5370-111-013	2	5371-111-005	2	5371-111-005	2
2	Armature Hub	540-1638	1	540-1642	1	540-1642	1	540-2053	1	540-2053	1
3	Retaining Ring	748-0445	1	748-0676	1	748-0676	1				
4	Lockwasher							950-0372	6	950-0372	6
5	Capscrew							797-0081	6	797-0081	6
6a	Retaining Ring	748-0113	1	748-0101	1	748-0101	1	748-0112	1	748-0112	1
6b	Retaining Ring	748-0113	1								
7	Ball Bearing	166-0149	1	166-0101	1	166-0101	1	166-0142	1	166-0142	1
8	Magnet		1		1		1		1		1
	6 volt	5370-631-008		5370-631-002		5370-631-002		5371-631-002		5371-631-002	
	24 volt	5370-631-010		5370-631-005		5370-631-005		5371-631-005		5371-631-005	
9	90 volt	5370-631-007		5370-631-003		5370-631-003		5371-631-003		5371-631-003	
	Housing	535-0165	1	535-0162	1	535-0162	1	535-0163	1	535-0163	1
10	Setscrew	797-0471	4	797-0471	4	797-0471	4	797-0103	4	797-0103	4
11	Shaft	798-0046	1	798-0128	1	798-0085	1	798-0051	1	798-0254	1
12	Key	590-0029	1	590-0029	1	590-0029	1	590-0019	1	590-0124	1
13	Ball Bearing	166-0155	1	166-0143	1	166-0143	1	166-0144	1	166-0144	1
14	Mounting Accessory	5370-101-040	1	5370-101-040	1	5370-101-040	1	5371-101-020	1	5371-101-020	1
	14-1 Capscrew	797-1378	4	797-1378	4	797-1378	4	797-1440	4	797-1440	4
	14-2 Washer	950-0354	4	950-0354	4	950-0354	4	950-0111	4	950-0111	4
	14-3 Adapter			807-0218	1			104-0321	1	104-0321	1
	14-4 Capscrew							797-1442	4	797-1442	4
14-5 Washer							950-0101	4	950-0101	4	
15	Key	590-0043	1	590-0084	1	590-0084	1				
16	Rotor Assembly (with fan and hub)	5370-751-019	1	5370-751-022	1	5370-751-017	1	5371-751-012	1	5371-751-031	1
17	Field (with housing)		1		1		1		1		1
	6 volt	5370-451-062		5370-451-057		5370-451-057		5371-451-027		5371-451-027	
	24 volt	5370-451-064		5370-451-059		5370-451-059		5371-451-029		5371-451-029	
90 volt	5370-451-063		5370-451-058		5370-451-058		5371-451-028		5371-451-028		
18	Retaining Ring	748-0101	1	748-0101	1	748-0101	1	748-0558	1	748-0558	1
19	Bearing	166-0150	1	166-0101	1	166-0101	1	166-0168	1	166-0168	1
20	Retaining Ring	748-0018	1	748-0001	1	748-0001	1	748-0067	1	748-0067	1
23	Conduit Box (Optional)	5370-101-042	1	5370-101-042	1	5370-101-042	1	5370-101-042	1	5370-101-042	1
24	Set Screw	797-1098	2	797-0069	2	797-0069	2	797-1098	2	797-1098	2
25	Input Key	5370-101-072	1	5370-101-072	1	5370-101-072	1	5371-101-043	1	5371-101-044	1

Note: As of June, 2000 all rotors are manufactured as a single piece design.
The rotor assembly part number remains the same and now includes the hub and set screws.

Refer to Service Manual P-213.
These units meet the standards of UL 508 and are listed under guide card #NMTR 2, file #59164.



Service Parts

UM Series UniModule

GEN 2 Design – UM-1040 Clutch/Brake Combination

Sizes 50, 100 and 180

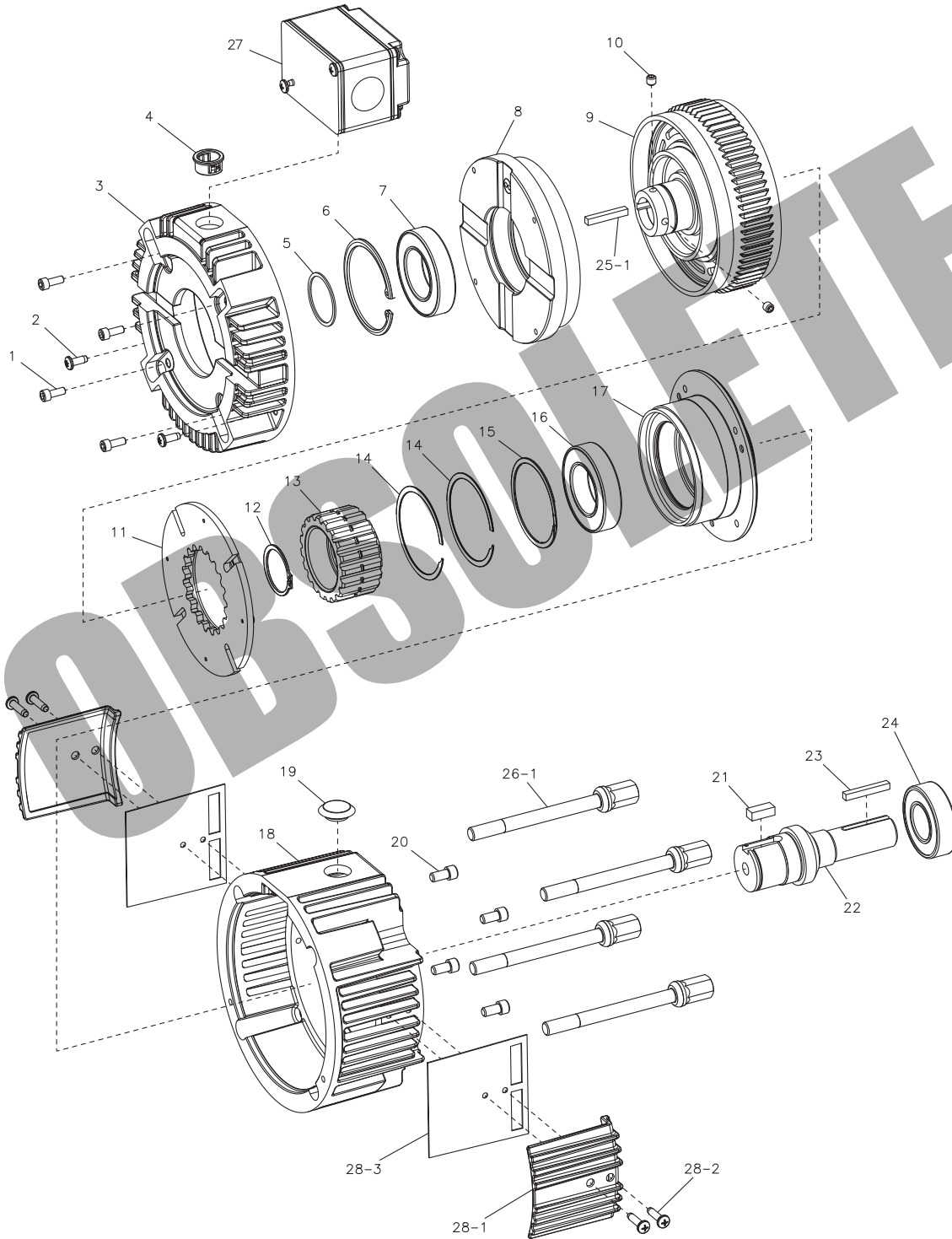

Service Parts

GEN 2 Design – UM-1040 Clutch/Brake Combination Sizes 50, 100 and 180

Component Parts

Item	Description	UM-50		UM-100		UM-180	
		Part No.	Qty.	Part No.	Qty.	Part No.	Qty.
1	Field Mounting Screw	797-1214	4	797-1214	4	797-1214	4
2	Screw	797-1568	2	797-1568	2	797-1568	2
3	Housing	535-0204	1	535-0204	1	535-0204	1
4	Bushing	572-0522	1	572-0522	1	572-0522	1
5	Retaining Ring	748-0018	1	748-0018	1	748-0018	1
6	Retaining Ring	748-0561	1	748-0561	1	748-0561	1
7	Ball Bearing	166-0150	1	166-0150	1	166-0150	1
8	Field Assembly		1		1		1
	6 Volt	5370-451-201		5370-451-206		5370-451-206	
	24 Volt	5370-451-203		5370-451-208		5370-451-208	
	90 Volt	5370-451-204		5370-451-209		5370-451-209	
9	Rotor Assembly	5370-751-019	1	5370-751-049	1	5370-751-051	1
10	Set Screw	797-1098	2	797-0069	2	797-0069	2
11	Armature Assembly	5370-111-022	1	5370-111-013	1	5370-111-013	1
12	Retaining Ring	748-0445	1	748-0676	1	748-0676	1
13	Armature Hub	540-1638	1	540-2038	1	540-2038	1
14	Armature Hub Retaining Ring			748-0450	2	748-0450	2
15	Retaining Ring	748-2044	1	748-0101	1	748-0101	1
16	Ball Bearing	166-0143	1	166-0150	1	166-0150	1
17	Bearing Hub	690-0276	1	690-0278	1	690-0278	1
18	Housing	535-0207	1	535-0207	1	535-0207	1
19	Plug	680-0037	1	680-0037	1	680-0037	1
20	Hub Mounting Screw	797-0077	4	797-1358	4	797-1358	4
21	Key	590-0043	1	590-0084	1	590-0084	1
22	Shaft	798-0298	1	798-0301	1	798-0304	1
23	Key	590-0029	1	590-0029	1	590-0029	1
24	Ball Bearing	166-0143	1	166-0143	1	166-0143	1
25	Mounting Accessory	5370-101-072	1	5370-101-072	1	5370-101-072	1
	25-1 Key	590-0142	1	590-0142	1	590-0142	1
26	Mounting Accessory	5370-101-075	1	5370-101-075	1	5370-101-075	1
	26-1 Tie Bolt	825-0014	4	825-0014	4	825-0014	4
27	Conduit Box (Optional)	5370-101-042	1	5370-101-042	1	5370-101-042	1
28	Cover Kit (Optional)	5370-101-076	1	5370-101-076	1	5370-101-076	1
	28-1 Cover	258-1227	2	258-1227	2	258-1227	2
	28-2 Screw	797-1562	4	797-1562	4	797-1562	4
	28-3 Gasket	495-0042	2	495-0042	2	495-0042	2

Refer to service manual P-273-4.

These units meet the standards of UL 508 and are listed under guide card #NMTR2, file #59164.



Service Parts

UM Series UniModule

Original Design – UM-1040 Clutch Combination

Sizes 50, 100, 180, 210 and 215

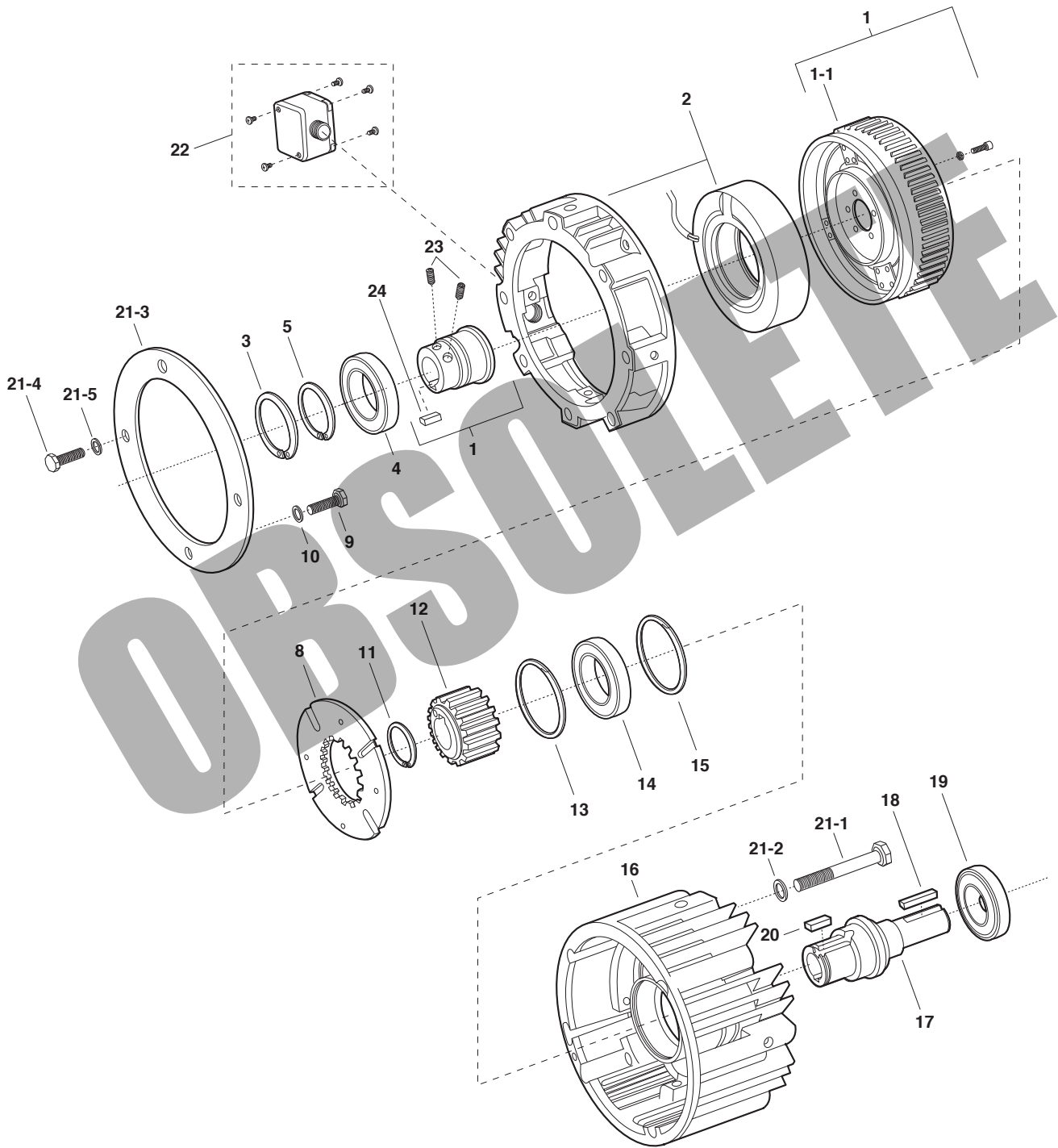

Service Parts

Original Design – UM-1040 Clutch Combination Sizes 50, 100, 180, 210 and 215

Component Parts (Gray shaded areas indicate original design parts which will be available for a limited time)

Item	Description	UM-50		UM-100		UM-180		UM-210		UM-215	
		Part No.	Qty.	Part No.	Qty.	Part No.	Qty.	Part No.	Qty.	Part No.	Qty.
1	Rotor Assembly (with fan and hub)	5370-751-019	1	5370-751-022	1	5370-751-017	1	5371-751-012	1	5371-751-031	1
2	Field (with housing)		1		1		1		1		1
	6 volt	5370-451-062		5370-451-057		5370-451-057		5371-451-027		5371-451-027	
	24 volt	5370-451-064		5370-451-059		5370-451-059		5371-451-029		5371-451-029	
	90 volt	5370-451-063		5370-451-058		5370-451-058		5371-451-028		5371-451-028	
3	Retaining Ring	748-0101	1	748-0101	1	748-0101	1	748-0558	1	748-0558	1
4	Bearing	166-0150	1	166-0101	1	166-0101	1	166-0168	1	166-0168	1
5	Retaining Ring	748-0018	1	748-0001	1	748-0001	1	748-0067	1	748-0067	1
8	Armature Assembly	5370-111-011	1	5370-111-013	1	5370-111-013	1	5371-111-005	1	5371-111-005	1
9	Capscrew							797-0081	6	797-0081	6
10	Lockwasher							950-0372	6	950-0372	6
11	Retaining Ring	748-0445	1	748-0676	1	748-0676	1				
12	Hub	540-1638	1	540-1642	1	540-1642	1	540-2053	1	540-2053	1
13	Retaining Ring	748-0113	1	748-0101	1	748-0101	1	748-0112	1	748-0112	1
14	Ball Bearing	166-0149	1	166-0101	1	166-0101	1	166-0142	1	166-0142	1
15	Retaining Ring	748-0113	1								
16	Housing	535-0167	1	535-0168	1	535-0168	1	535-0169	1	535-0169	1
17	Shaft	798-0046	1	798-0128	1	798-0085	1	798-0051	1	798-0254	1
18	Key	590-0029	1	590-0029	1	590-0029	1	590-0019	1	590-0124	1
19	Ball Bearing	166-0155	1	166-0143	1	166-0143	1	166-0144	1	166-0144	1
20	Key	590-0043	1	590-0084	1	590-0084	1				
21	Mounting Accessory	5370-101-040	1	5370-101-040	1	5370-101-040	1	5371-101-020	1	5371-101-020	1
	21-1 Capscrew	797-1378	4	797-1378	4	797-1378	4	797-1440	4	797-1440	4
	21-2 Lockwasher	950-0354	4	950-0354	4	950-0354	4	950-0111	4	950-0111	4
	21-3 Adapter			807-0218	1			104-0321	1	104-0321	1
	21-4 Capscrew							797-1442	4	797-1442	4
	21-5 Lockwasher							950-0101	4	950-0101	4
22	Conduit Box (Optional)	5370-101-042	1	5370-101-042	1	5370-101-042	1	5370-101-042	1	5370-101-042	1
23	Set Screw	797-1098	2	797-0069	2	797-0069	2	797-1098	2	797-1098	2
24	Input Key	5370-101-072	1	5370-101-072	1	5370-101-072	1	5371-101-043	1	5371-101-044	1

Note: As of June, 2000 all rotors are manufactured as a single piece design. The rotor assembly part number remains the same and now includes the hub and set screws.

Refer to Service Manual P-213.

These units meet the standards of UL 508 and are listed under guide card #NMTR 2, file #59164.



Service Parts

UM Series UniModule

GEN 2 Design – UM-2030 Clutch/Brake Combination

Sizes 50, 100 and 180

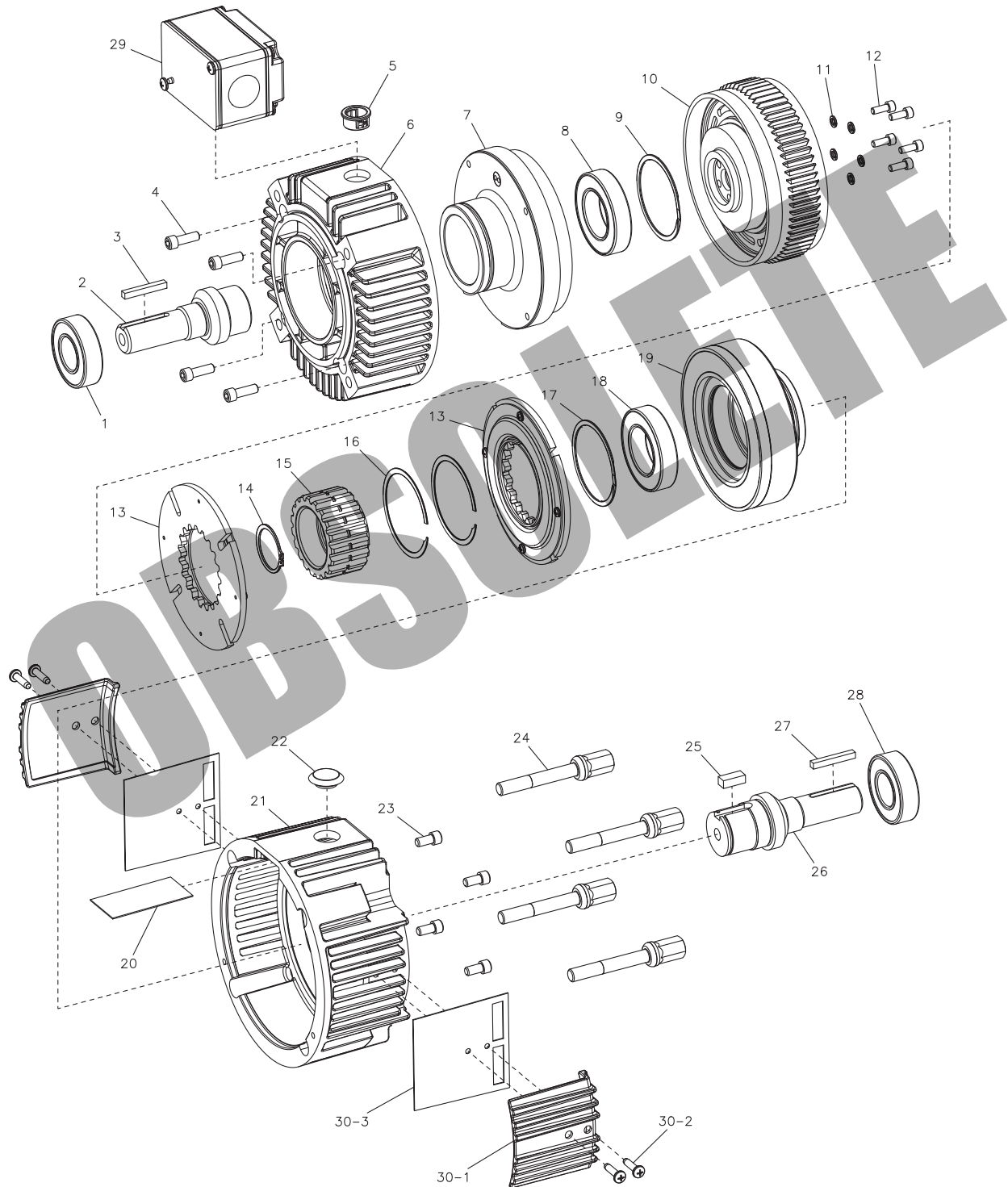

Service Parts

GEN 2 Design – UM-2030 Clutch/Brake Combination Sizes 50, 100 and 180

Component Parts

Item	Description	UM-50		UM-100		UM-180	
		Part No.	Qty.	Part No.	Qty.	Part No.	Qty.
1	Ball Bearing	166-0143	1	166-0143	1	166-0143	1
2	Shaft	798-0300	1	798-0303	1	798-0306	1
3	Key	590-0029	1	590-0029	1	590-0029	1
4	Field Mounting Screw	797-0077	4	797-0077	4	797-0077	4
5	Bushing	572-0522	1	572-0522	1	572-0522	1
6	Housing	535-0205	1	535-0205	1	535-0205	1
7	Field Assembly		1		1		1
	6 Volt	5370-451-211		5370-451-216		5370-451-216	
	24 Volt	5370-451-213		5370-451-218		5370-451-218	
	90 Volt	5370-451-214		5370-451-219		5370-451-219	
8	Ball Bearing	166-0143	1	166-0150	1	166-0150	1
9	Retaining Ring	748-2044	1	748-0101	1	748-0101	1
10	Rotor Assembly	5370-751-006	1	5370-751-053	1	5370-751-053	1
11	Washer	950-0436	4	950-0436	5	950-0436	5
12	Screw	797-1294	4	797-1214	5	797-1214	5
13	Armature Assembly	5370-111-022	2	5370-111-013	2	5370-111-013	2
14	Retaining Ring	748-0445	1	748-0676	1	748-0676	1
15	Armature Hub	540-1638	1	540-2038	1	540-2038	1
16	Armature Hub Retaining Ring			748-0450	2	748-0450	2
17	Retaining Ring	748-2044	1	748-0101	1	748-0101	1
18	Ball Bearing	166-0143	1	166-0150	1	166-0150	1
19	Magnet Assembly		1		1		1
	6 Volt	5370-631-201		5370-631-216		5370-631-216	
	24 Volt	5370-631-203		5370-631-218		5370-631-218	
	90 Volt	5370-631-204		5370-631-219		5370-631-219	
20	Insulator	572-1029	1	572-1029	1	572-1029	1
21	Housing	535-0206	1	535-0206	1	535-0206	1
22	Plug	680-0037	1	680-0037	1	680-0037	1
23	Magnet Mounting Screw	797-0077	4	797-1358	4	797-1358	4
24	Tie Bolt	825-0013	4	825-0013	4	825-0013	4
25	Key	590-0043	1	590-0084	1	590-0084	1
26	Shaft	798-0298	1	798-0301	1	798-0304	1
27	Key	590-0029	1	590-0029	1	590-0029	1
28	Ball Bearing	166-0143	1	166-0143	1	166-0143	1
29	Conduit Box (Optional)	5370-101-042	1	5370-101-042	1	5370-101-042	1
30	Cover Kit (Optional)	5370-101-076	1	5370-101-076	1	5370-101-076	1
	30-1 Cover	258-1227	2	258-1227	2	258-1227	2
	30-2 Screw	797-1562	4	797-1562	4	797-1562	4
	30-3 Gasket	495-0042	2	495-0042	2	495-0042	2

Refer to service manual P-273-4.

These units meet the standards of UL 508 and are listed under guide card #NMTR2, file #59164.



Service Parts

UM Series UniModule

Original Design – UM-2030 Clutch/Brake Combination

Sizes 50, 100, 180, 210 and 215

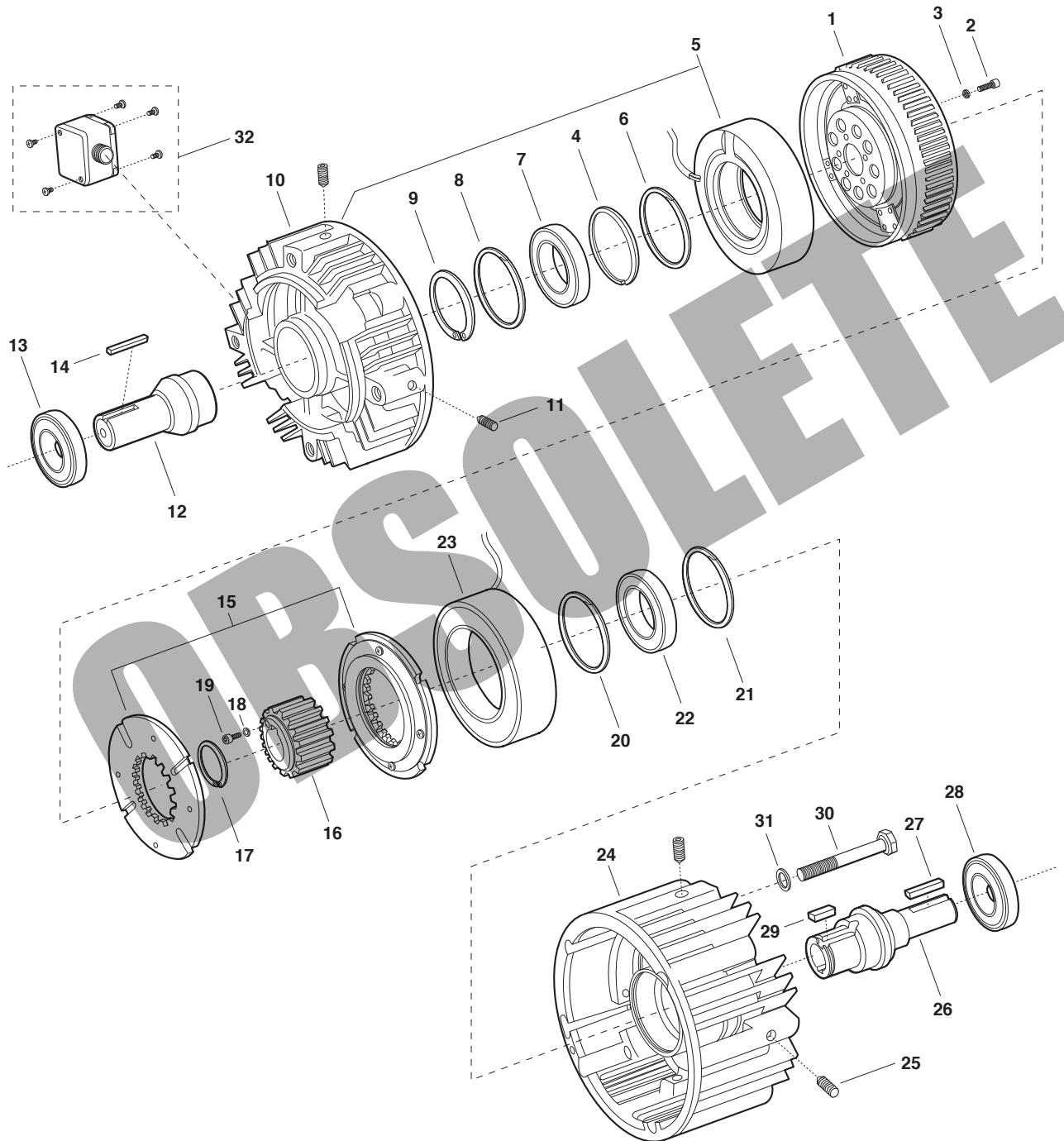

Service Parts

Original Design – UM-2030 Clutch/Brake Combination Sizes 50, 100, 180, 210 and 215

Component Parts (Gray shaded areas indicate original design parts which will be available for a limited time)

Item	Description	UM-50		UM-100		UM-180		UM-210		UM-215	
		Part No.	Qty.	Part No.	Qty.	Part No.	Qty.	Part No.	Qty.	Part No.	Qty.
1	Rotor Assembly w/fan	5370-751-006	1	5370-751-009	1	5370-751-009	1	5371-751-007	1	5371-751-007	1
2	Capscrew	797-1294	4	797-1214	5	797-1214	5	797-0083	6	797-0083	6
3	Lockwasher	950-0436	4	950-0436	5	950-0436	5	950-0372	6	950-0372	6
4	Spacer			807-0062	1	807-0062	1	807-0061	1	807-0061	1
5	Field (with housing UM-50-2030 only) 1			1		1		1		1	
	6 volt	5370-451-072		5370-451-007		5370-451-007		5371-451-002		5371-451-002	
	24 volt	5370-451-074		5370-451-005		5370-451-005		5371-451-005		5371-451-005	
	90 volt	5370-451-073		5370-451-008		5370-451-008		5371-451-003		5371-451-003	
6	Retaining Ring	748-0113	1	748-0101	1	748-0101	1	748-0112	1	748-0112	1
7	Ball Bearing	166-0149	1	166-0101	1	166-0101	1	166-0142	1	166-0142	1
8	Retaining Ring	748-0113	1								
9	Retaining Ring	748-0017	1								
10	Housing			535-0164	1	535-0164	1	535-0129	1	535-0129	1
11	Setscrew			797-0471	4	797-0471	4	797-0103	4	797-0103	4
12	Shaft	798-0047	1	798-0129	1	798-0124	1	798-0123	1	798-0255	1
13	Bearing	166-0155	1	166-0143	1	166-0143	1	166-0144	1	166-0144	1
14	Key	590-0029	1	590-0029	1	590-0029	1	590-0019	1	590-0124	1
15	Armature Assembly	5370-111-011	2	5370-111-013	2	5370-111-013	2	5371-111-005	2	5371-111-005	2
16	Armature Hub	540-1638	1	540-1642	1	540-1642	1	540-2053	1	540-2053	1
17	Retaining Ring	748-0445	1	748-0676	1	748-0676	1				
18	Lockwasher							950-0372	6	950-0372	6
19	Capscrew							797-0081	6	797-0081	6
20	Retaining Ring	748-0113	1	748-0101	1	748-0101	1	748-0112	1	748-0112	1
21	Retaining Ring	748-0113	1								
22	Ball Bearing	166-0149	1	166-0101	1	166-0101	1	166-0142	1	166-0142	1
23	Magnet										
	6 volt	5370-631-008		5370-631-002		5370-631-002		5371-631-002		5371-631-002	
	24 volt	5370-631-010		5370-631-005		5370-631-005		5371-631-005		5371-631-005	
	90 volt	5370-631-007		5370-631-003		5370-631-003		5371-631-003		5371-631-003	
24	Housing	535-0165	1	535-0162	1	535-0162	1	535-0163	1	535-0163	1
25	Setscrew	797-0471	4	797-0471	4	797-0471	4	797-0103	4	797-0103	4
26	Shaft	798-0046	1	798-0128	1	798-0085	1	798-0051	1	798-0251	1
27	Key	590-0029	1	590-0029	1	590-0029	1	590-0019	1	590-0124	1
28	Ball Bearing	166-0155	1	166-0143	1	166-0143	1	166-0144	1	166-0144	1
29	Key	590-0043	1	590-0084	1	590-0084	1				
30	Capscrew	797-0353	4	797-0353	4	797-0353	4	797-1075	4	797-1075	4
31	Lockwasher	950-0354	4	950-0354	4	950-0354	4	950-0032	4	950-0032	4
32	Conduit Box (Optional)	5370-101-042	1	5370-101-042	1	5370-101-042	1	5370-101-042	1	5370-101-042	1

Refer to Service Manual P-213.

These units meet the standards of UL 508 and are listed under guide card #NMTR2, file #59164.



Service Parts

UM Series UniModule

GEN 2 Design – UM-3040 Clutch Combination-Base Mounted Sizes 50, 100 and 180

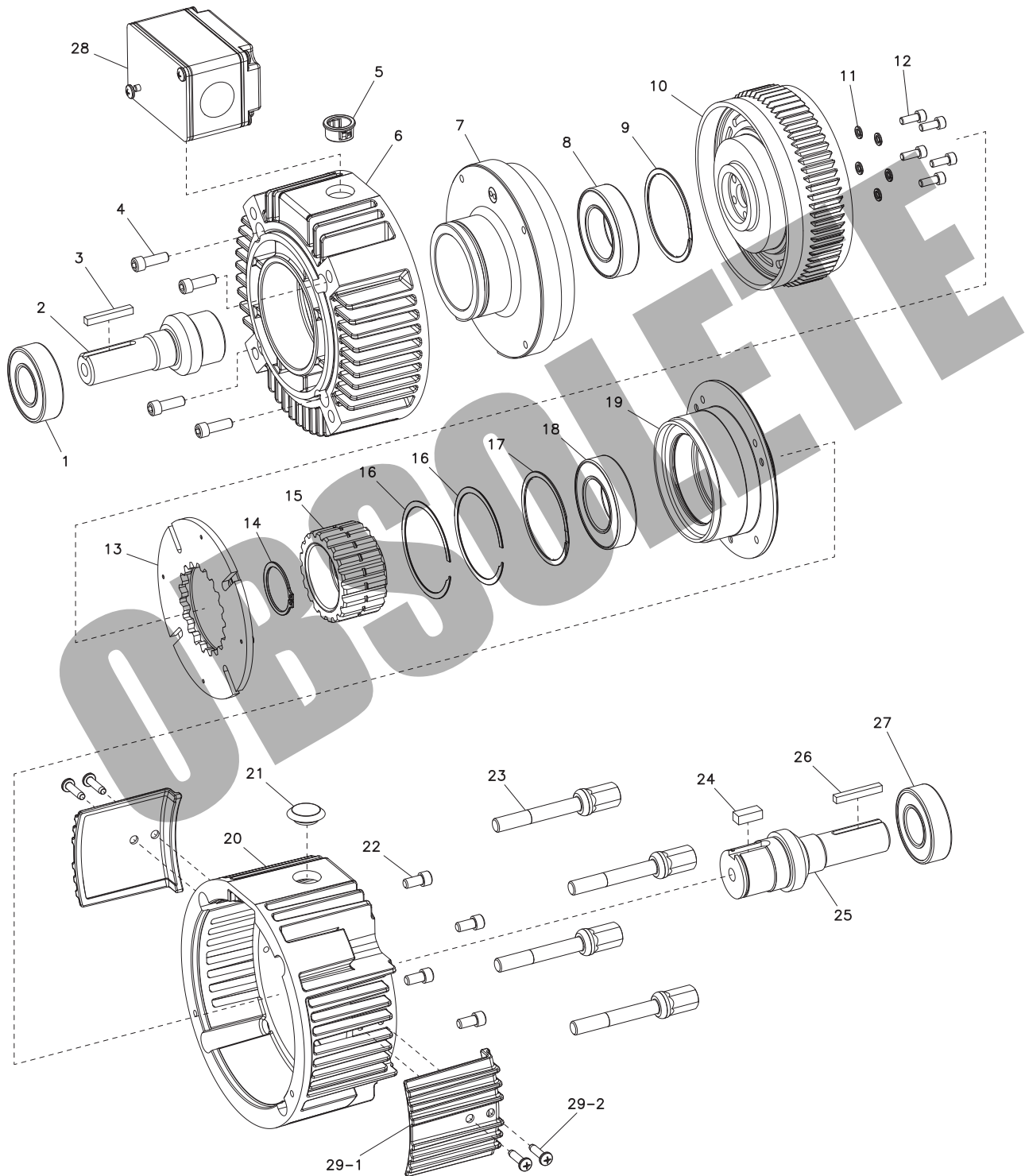

Service Parts

GEN 2 Design – UM-3040 Clutch Combination-Base Mounted Sizes 50, 100 and 180

Component Parts

Item	Description	UM-50		UM-100		UM-180	
		Part No.	Qty.	Part No.	Qty.	Part No.	Qty.
1	Ball Bearing	166-0143	1	166-0143	1	166-0143	1
2	Shaft	798-0300	1	798-0303	1	798-0306	1
3	Key	590-0029	1	590-0029	1	590-0029	1
4	Field Mounting Screw	797-0077	4	797-0077	4	797-0077	4
5	Bushing	572-0522	1	572-0522	1	572-0522	1
6	Housing	535-0205	1	535-0205	1	535-0205	1
7	Field Assembly		1		1		1
	6 Volt	5370-451-211		5370-451-216		5370-451-216	
	24 Volt	5370-451-213		5370-451-218		5370-451-218	
	90 Volt	5370-451-214		5370-451-219		5370-451-219	
8	Ball Bearing	166-0143	1	166-0150	1	166-0150	1
9	Retaining Ring	748-2044	1	748-0101	1	748-0101	1
10	Rotor Assembly	5370-751-006	1	5370-751-053	1	5370-751-053	1
11	Washer	950-0436	4	950-0436	5	950-0436	5
12	Screw	797-1294	4	797-1214	5	797-1214	5
13	Armature Assembly	5370-111-022	1	5370-111-013	1	5370-111-013	1
14	Retaining Ring	748-0445	1	748-0676	1	748-0676	1
15	Armature Hub	540-1638	1	540-2038	1	540-2038	1
16	Armature Hub Retaining Ring			748-0450	2	748-0450	2
17	Retaining Ring	748-2044	1	748-0101	1	748-0101	1
18	Ball Bearing	166-0143	1	166-0150	1	166-0150	1
19	Bearing Hub	690-0276	1	690-0278	1	690-0278	1
20	Housing	535-0207	1	535-0207	1	535-0207	1
21	Plug	680-0037	1	680-0037	1	680-0037	1
22	Hub Mounting Screw	797-0077	4	797-1358	4	797-1358	4
23	Tie Bolt	825-0013	4	825-0013	4	825-0013	4
24	Key	590-0043	1	590-0084	1	590-0084	1
25	Shaft	798-0298	1	798-0301	1	798-0304	1
26	Key	590-0029	1	590-0029	1	590-0029	1
27	Ball Bearing	166-0143	1	166-0143	1	166-0143	1
28	Conduit Box (Optional)	5370-101-042	1	5370-101-042	1	5370-101-042	1
29	Cover Kit (Optional)	5370-101-076	1	5370-101-076	1	5370-101-076	1
	29-1 Cover	258-1227	2	258-1227	2	258-1227	2
	29-2 Screw	797-1562	4	797-1562	4	797-1562	4

Refer to service manual P-273-4.
These units meet the standards of UL 508 and are listed under guide card #NMTR2, file #59164.



Service Parts

UM Series UniModule

Original Design – UM-3040 Clutch Combination–Base Mounted

Sizes 50, 100, 180, 210 and 215

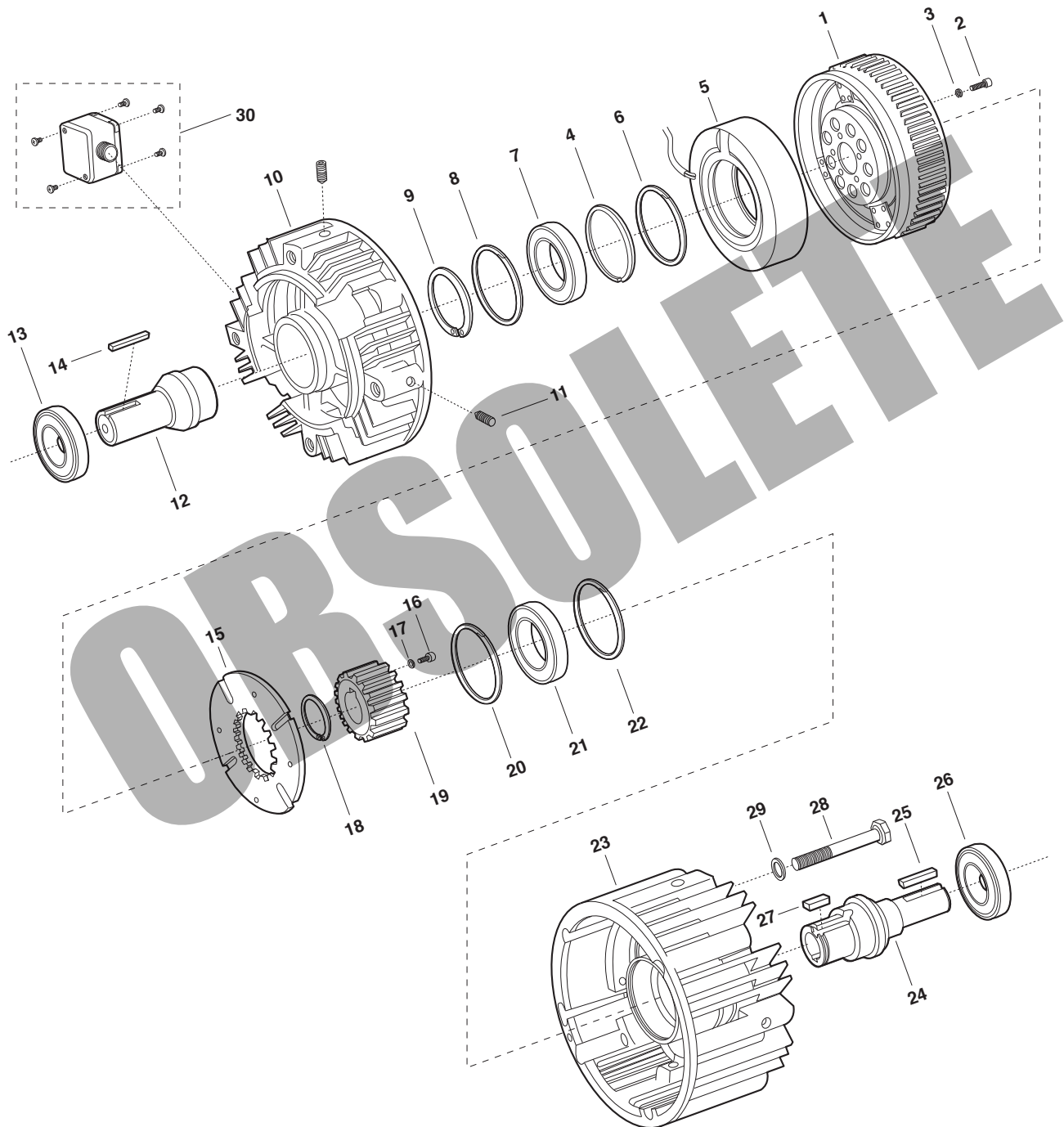

Service Parts

Original Design – UM-3040 Clutch Combination–Base Mounted Sizes 50, 100, 180, 210 and 215

Component Parts (Gray shaded areas indicate original design parts which will be available for a limited time)

Item	Description	UM-50		UM-100		UM-180		UM-210		UM-215	
		Part No.	Qty.	Part No.	Qty.	Part No.	Qty.	Part No.	Qty.	Part No.	Qty.
1	Rotor Assembly w/fan	5370-751-006	1	5370-751-009	1	5370-751-009	1	5371-751-007	1	5371-751-007	1
2	Capscrew	797-1294	4	797-1214	5	797-1214	5	797-0083	6	797-0083	6
3	Lockwasher	950-0436	4	950-0436	5	950-0436	5	950-0372	6	950-0372	6
4	Spacer			807-0062	1	807-0062	1	807-0061	1	807-0061	1
5	Field (with housing UM-50-3040 only)		1		1		1		1		1
	6 volt	5370-451-072		5370-451-007		5370-451-007		5371-451-002		5371-451-002	
	24 volt	5370-451-074		5370-451-005		5370-451-005		5371-451-005		5371-451-005	
	90 volt	5370-451-073		5370-451-008		5370-451-008		5371-451-003		5371-451-003	
6	Retaining Ring	748-0113	1	748-0101	1	748-0101	1	748-0112	1	748-0112	1
7	Ball Bearing	166-0149	1	166-0101	1	166-0101	1	166-0142	1	166-0142	1
8	Retaining Ring	748-0113	1								
9	Retaining Ring	748-0017	1								
10	Housing			535-0164	1	535-0164	4	535-0129	1	535-0129	1
11	Setscrew			797-0471	4	797-0471	4	797-0103	4	797-0103	4
12	Shaft	798-0047	1	798-0129	1	798-0124	1	798-0123	1	798-0255	1
13	Bearing	166-0155	1	166-0143	1	166-0143	1	166-0144	1	166-0144	1
14	Key	590-0029	1	590-0029	1	590-0029	1	590-0019	1	590-0124	1
15	Armature Assembly	5370-111-011	1	5370-111-013	1	5370-111-013	1	5371-111-005	1	5371-111-005	1
16	Capscrew							797-0081	6	797-0081	6
17	Lockwasher							950-0372	6	950-0372	6
18	Retaining Ring	748-0445	1	748-0676	1	748-0676	1				
19	Hub	540-1638	1	540-1642	1	540-1642	1	540-2053	1	540-2053	1
20	Retaining Ring	748-0113	1	748-0101	1	748-0101	1	748-0112	1	748-0112	1
21	Ball Bearing	166-0149	1	166-0101	1	166-0101	1	166-0142	1	166-0142	1
22	Retaining Ring	748-0113	1								
23	Housing	535-0167	1	535-0168	1	535-0168	1	535-0169	1	535-0169	1
24	Shaft	798-0046	1	798-0128	1	798-0085	1	798-0051	1	798-0251	1
25	Key	590-0029	1	590-0029	1	590-0029	1	590-0019	1	590-0124	1
26	Ball Bearing	166-0155	1	166-0143	1	166-0143	1	166-0144	1	166-0144	1
27	Key	590-0043	1	590-0084	1	590-0084	1				
28	Capscrew	797-0353	4	797-0353	4	797-0353	4	797-1075	4	797-1075	4
29	Lockwasher	950-0354	4	950-0354	4	950-0354	4	950-0032	4	950-0032	4
30	Conduit Box (Optional)	5370-101-042	1	5370-101-042	1	5370-101-042	1	5370-101-042	1	5370-101-042	1

Refer to Service Manual P-213.

These units meet the standards of UL 508 and are listed under guide card #NMTR2, file #59164.



Service Parts

EM Series Electro Module

GEN 2 Design – EM-10 Motor Clutch Module

Sizes 50, 100 and 180

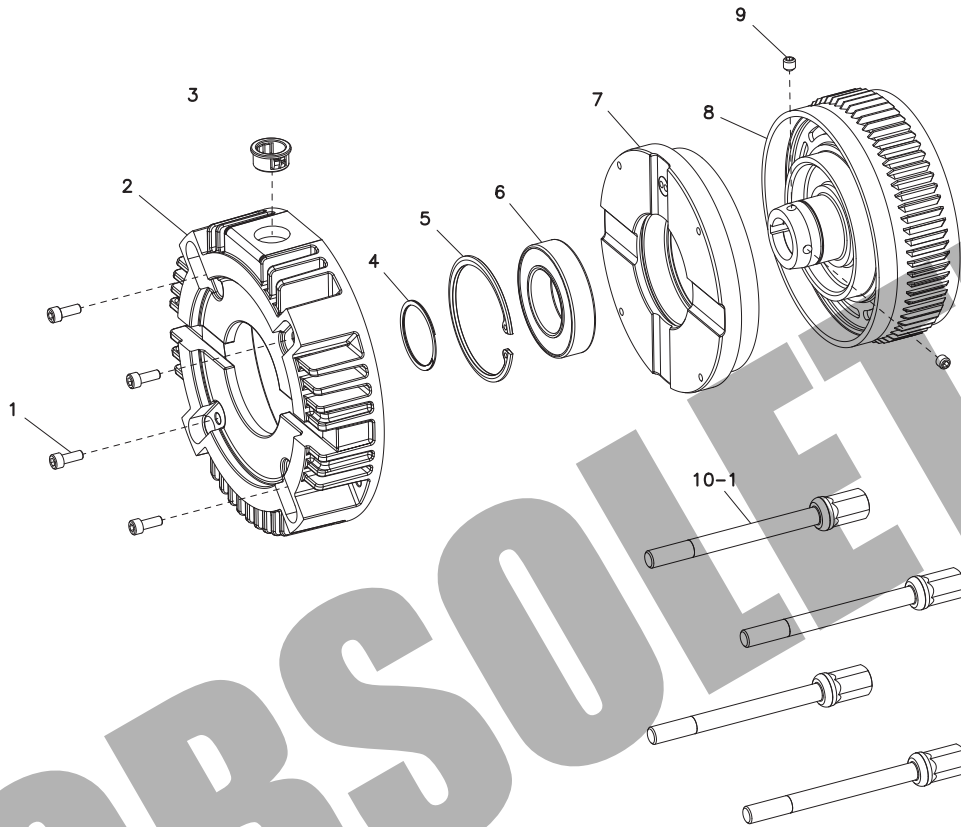

Component Parts

Item	Description	EM-50		EM-100		EM-180	
		Part No.	Qty.	Part No.	Qty.	Part No.	Qty.
1	Field Mounting Screw	797-1214	4	797-1214	4	797-1214	4
2	Housing	535-0204	1	535-0204	1	535-0204	1
3	Bushing	572-0522	1	572-0522	1	572-0522	1
4	Retaining Ring	748-0018	1	748-0018	1	748-0018	1
5	Retaining Ring	748-0561	1	748-0561	1	748-0561	1
6	Bearing	166-0150	1	166-0150	1	166-0150	1
7	Field Assembly		1		1		1
	6 Volt	5370-451-201		5370-451-206		5370-451-206	
	24 Volt	5370-451-203		5370-451-208		5370-451-208	
	90 Volt	5370-451-204		5370-451-209		5370-451-209	
8	Rotor Assembly	5370-751-019	1	5370-751-049	1	5370-751-051	1
9	Set Screw	797-1098	2	797-0069	2	797-0069	2
10	Mounting Accessory	5370-101-075	1	5370-101-075	1	5370-101-075	1
	10-1 Tie Bolt	825-0014	4	825-0014	4	825-0014	4

Refer to Service Manual P-273-5.
These units meet the standards of UL 508 and are listed under guide card #NMTR2, file #59164.



Service Parts

EM Series Electro Module

Original Design – EM-10 Motor Clutch Module

Sizes 50, 100, 180 and 210

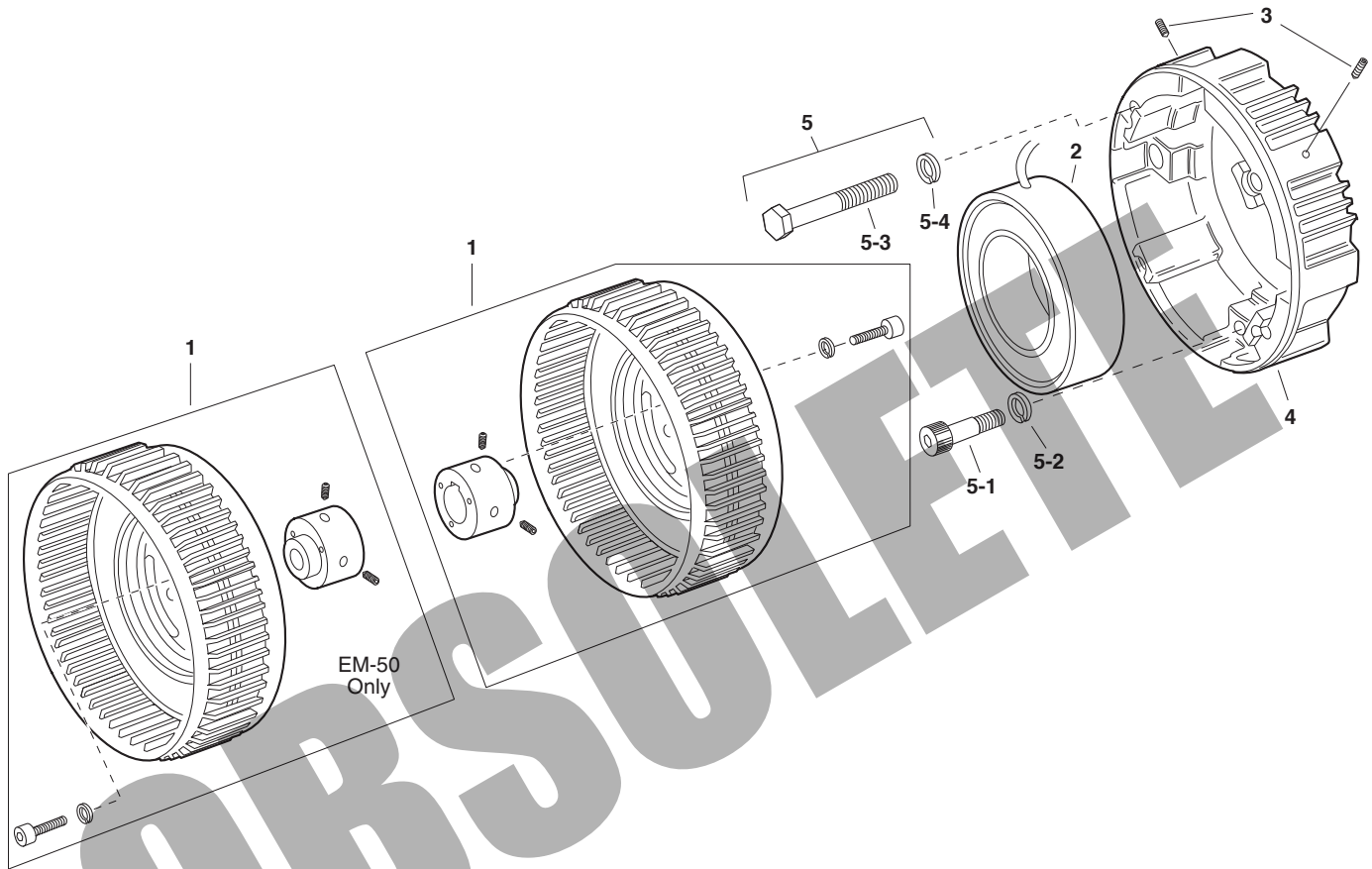

Component Parts (Gray shaded areas indicate original design parts which will be available for a limited time)

Item	Description	EM-50		EM-100		EM-180		EM-210	
		Part No.	Qty.	Part No.	Qty.	Part No.	Qty.	Part No.	Qty.
1*	Rotor Assembly w/fan & hub	5370-751-010	1	5370-751-013	1	5370-751-007	1	5371-751-005	1
	Field		1		1		1		1
2	6 volt	5370-451-011		5370-451-021		5370-451-021		5371-451-010	
	24 volt	5370-451-014		5370-451-024		5370-451-024		5371-451-013	
	90 volt	5370-451-012		5370-451-022		5370-451-022		5371-451-011	
3	Setscrew							797-0471	4
4	Adapter							104-0096	1
5	Mounting Accessory	5370-101-028	1	5370-101-013	1	5370-101-013	1	5371-101-008	1
	5-1 Capscrew	797-0293	4	797-0293	4	797-0293	4	797-1078	4
	5-2 Lockwasher	950-0128	4	950-0128	4	950-0128	4	950-0101	4
	5-3 Capscrew							797-1075	4
	5-4 Lockwasher							950-0032	4

*Shipped Assembled
 Refer to Service Manual P-213.
 These units meet the standards of UL 508 and are listed under guide card #NMTR2, file #59164.



Service Parts

EM Series Electro Module

GEN 2 Design – EM-20 Brake Module

Sizes 50, 100 and 180

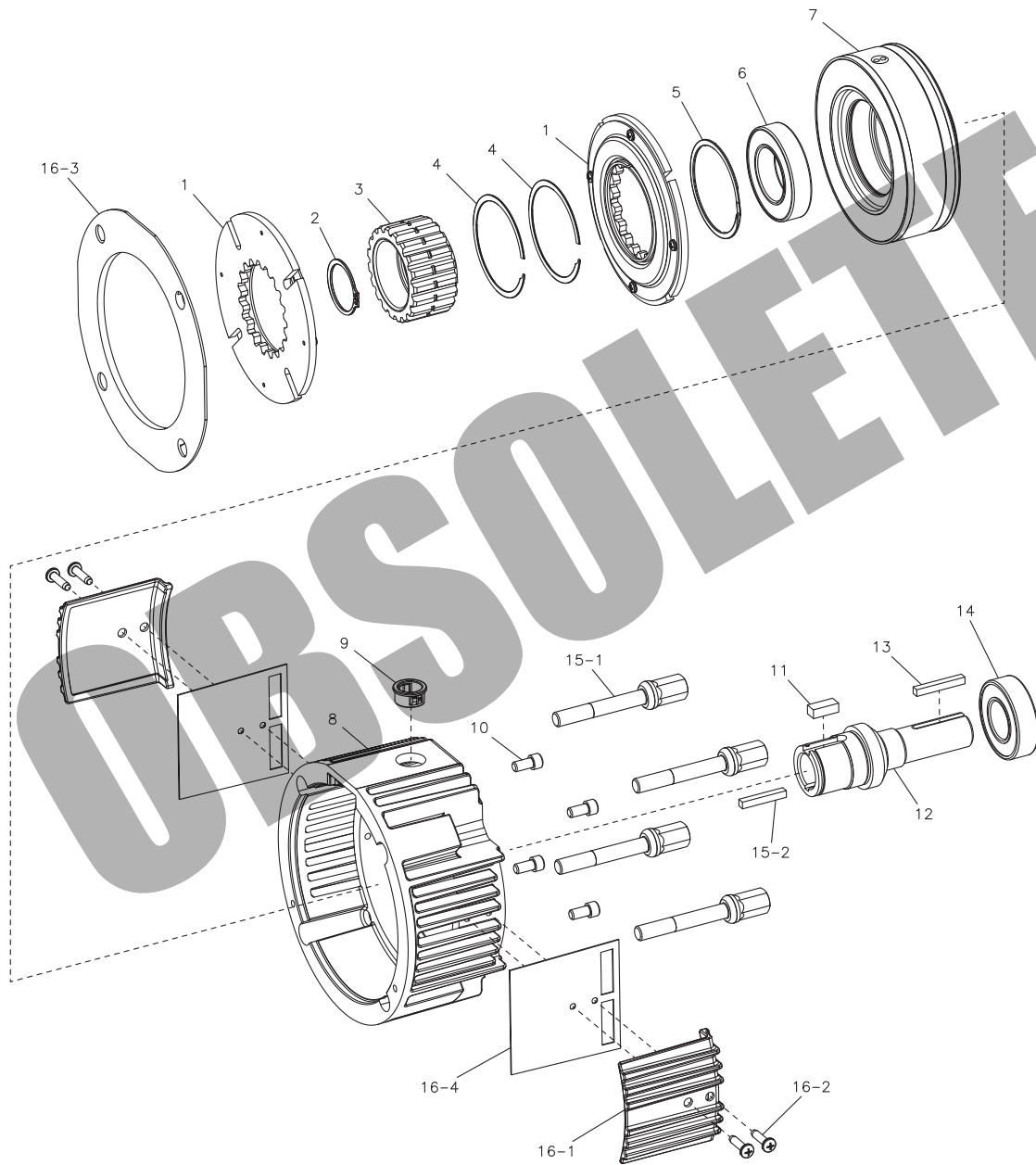

Service Parts

EM Series Electro Module

GEN 2 Design – EM-20 Brake Module Sizes 50, 100 and 180

Component Parts

Item	Description	EM-50		EM-100		EM-180	
		Part No.	Qty.	Part No.	Qty.	Part No.	Qty.
1	Armature Assembly	5370-111-022	2	5370-111-013	2	5370-111-013	2
2	Retaining Ring	748-0445	1	748-0676	1	748-0676	1
3	Armature Hub	540-1638	1	540-2038	1	540-2038	1
4	Armature Hub Retaining Ring			748-0450	2	748-0450	2
5	Retaining Ring	748-2044	1	748-0101	1	748-0101	1
6	Ball Bearing	166-0143	1	166-0150	1	166-0150	1
7	Magnet Assembly		1		1		1
	6 Volt	5370-631-201		5370-631-216		5370-631-216	
	24 Volt	5370-631-203		5370-631-218		5370-631-218	
	90 Volt	5370-631-204		5370-631-219		5370-631-219	
8	Housing	535-0206	1	535-0206	1	535-0206	1
9	Bushing	572-0522	1	572-0522	1	572-0522	1
10	Magnet Mounting Screw	797-0077	4	797-1358	4	797-1358	4
11	Key	590-0043	1	590-0084	1	590-0084	1
12	Shaft	798-0299	1	798-0302	1	798-0305	1
13	Key	590-0029	1	590-0029	1	590-0029	1
14	Ball Bearing	166-0143	1	166-0143	1	166-0143	1
15	Mounting Accessory	5370-101-077	1	5370-101-077	1	5370-101-077	1
	15-1 Tie Bolt	825-0013	4	825-0013	4	825-0013	4
	15-2 Key	590-0142	1	590-0142	1	590-0142	1
16a	Cover Kit (Optional, for brake only)	5370-101-082	1	5370-101-082	1	5370-101-082	1
	16-1 Vent Cover	258-1227	2	258-1227	2	258-1227	2
	16-2 Screw	797-1562	4	797-1562	4	797-1562	4
	16-3 Cover Plate	287-0135	1	287-0135	1	287-0135	1
	16-4 Gasket	495-0042	2	495-0042	2	495-0042	2
16b	Cover Kit (Optional, for clutch/brake combination)	5370-101-076	1	5370-101-076	1	5370-101-076	1
	16-1 Vent Cover	258-1227	2	258-1227	2	258-1227	2
	16-2 Screw	797-1562	4	797-1562	4	797-1562	4
	16-4 Gasket	495-0042	2	495-0042	2	495-0042	2

Refer to service manual P-273-5.

These units meet the standards of UL 508 and are listed under guide card #NMTR2, file #59164.



Service Parts

EM Series Electro Module

Original Design – EM-20 Brake Module

Sizes 50, 100, 180, 210 and 215

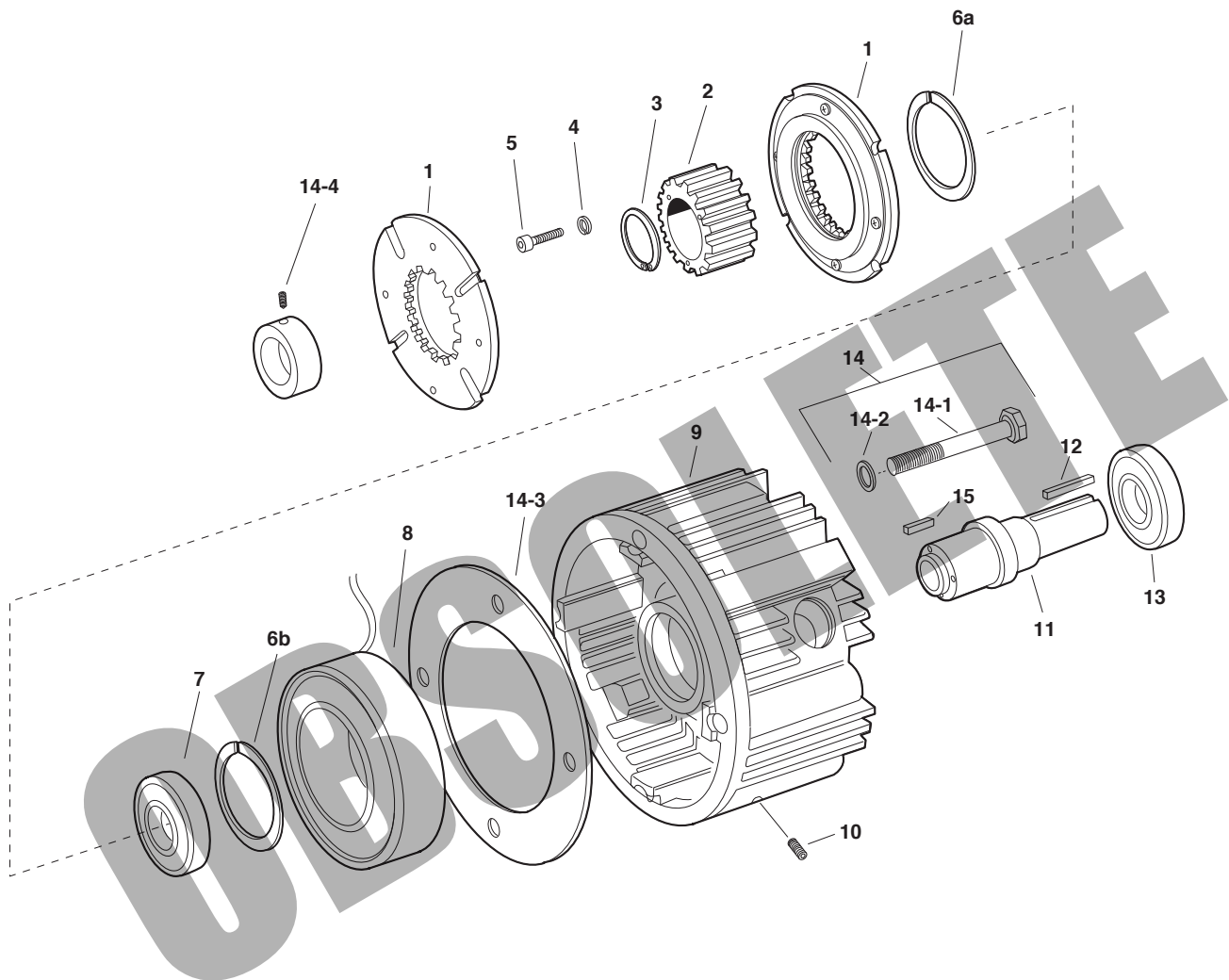

Service Parts

EM Series Electro Module

Original Design – EM-20 Brake Module Sizes 50, 100, 180, 210 and 215

Component Parts (Gray shaded areas indicate original design parts which will be available for a limited time)

Item	Description	EM-50		EM-100		EM-180		EM-210		EM-215	
		Part No.	Qty.	Part No.	Qty.	Part No.	Qty.	Part No.	Qty.	Part No.	Qty.
1	Armature	5370-111-011	2	5370-111-013	2	5370-111-013	2	5371-111-005	2	5371-111-005	1
2	Armature Hub	540-1638	1	540-1684	1	540-1642	1	540-2053	1	540-2039	1
3	Retaining Ring	748-0445	1	748-0676	1	748-0676	1				
4	Lockwasher							950-0372	6	950-0372	6
5	Capscrew							797-0081	6	797-008	6
6a	Retaining Ring	748-0113	1	748-0101	1	748-0101	1	748-0112	1	748-0112	1
6b	Retaining Ring	748-0113	1							748-2002	1
7	Ball Bearing	166-0149	1	166-0101	1	166-0101	1	166-0142	1	166-0142	1
8	Magnet		1		1		1		1		
	6 Volt	5370-631-008		5370-631-002		5370-631-002		5371-631-002			
	24 Volt	5370-631-010		5370-631-005		5370-631-005		5371-631-005		5371-631-005	1
	90 Volt	5370-631-007		5370-631-003		5370-631-003		5371-631-003		5371-631-003	1
9	Housing	535-0130	1	535-0132	1	535-0132	1	535-0033	1	535-0033	1
10	Setscrew	797-0471	4	797-0471	4	797-0471	4	797-0103	4	797-0103	4
11	Shaft	798-0045	1	798-0127	1	798-0086	1	798-0050	1	798-0268	1
12	Key - Output	590-0029	1	590-0029	1	590-0029	1	590-0019	1	590-0124	1
13	Ball Bearing	166-0155	1	166-0143	1	166-0143	1	166-0144	1	166-0144	1
14	Mounting Accessory	5370-101-017	1	5370-101-017	1	5370-101-023	1	5371-101-007	1	5371-101-007	1
	14-1 Capscrew	797-0353	4	797-0353	4	797-0353	4	797-1081	4	797-1081	4
	14-2 Washer	950-0354	4	950-0354	4	950-0354	4	950-0033	4	950-0033	4
	14-3 Spacer					807-0218	1				
	14-4 Collar					266-0002	1	266-0003	1	266-0003	1
15	Key	590-0043	1	590-0084	1	590-0084	1				
	Key Accessory - Input	5370-101-072	1	5370-101-072	1	5370-101-072	1	5371-101-043	1	5371-101-044	1

Refer to Service Manual P-213.

These units meet the standards of UL 508 and are listed under guide card #NMTR2, file #59164.



Service Parts

EM Series Electro Module

GEN 2 Design – EM-20MB Motor Brake Module

Sizes 50 and 180

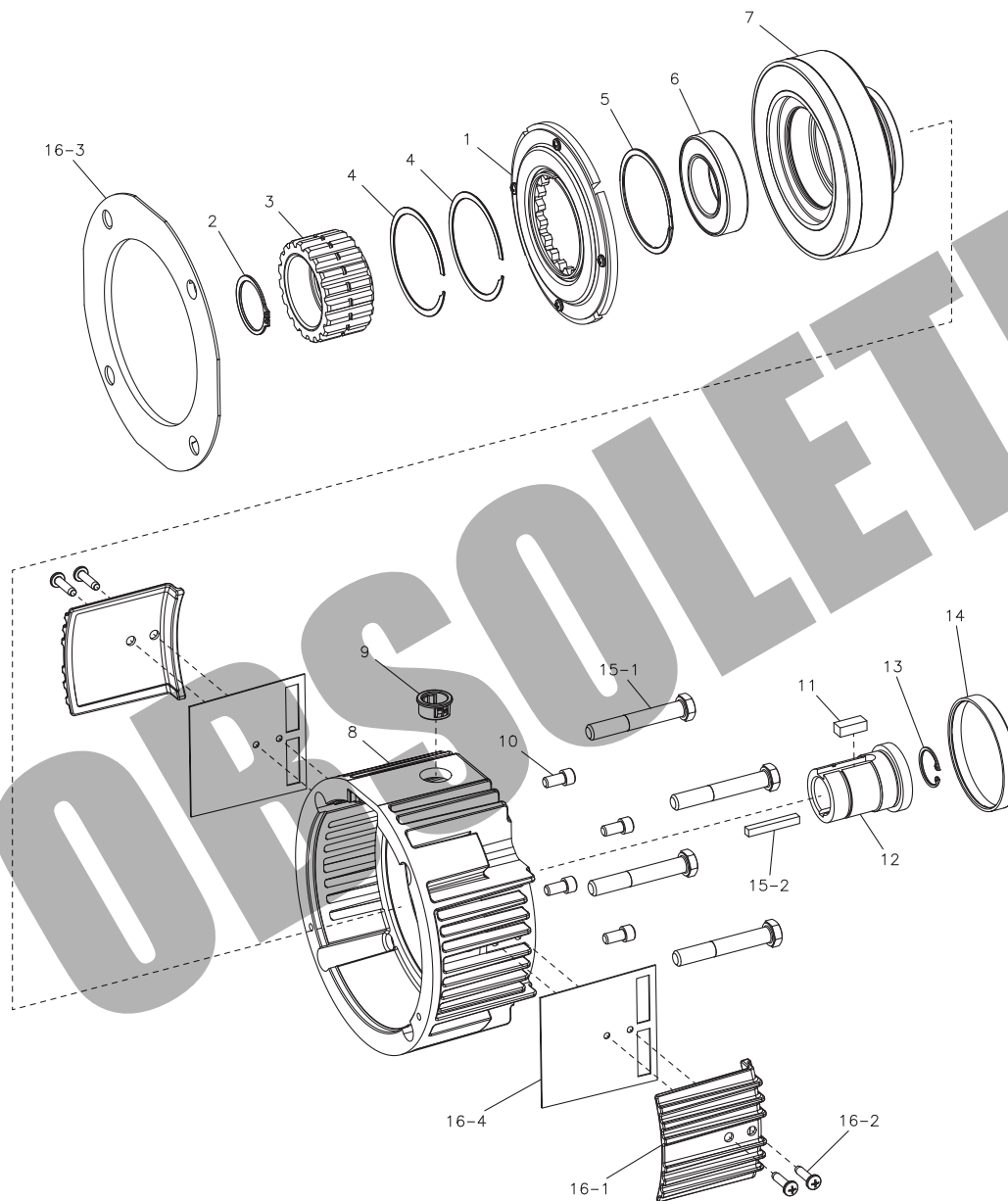

Service Parts

GEN 2 Design – EM-20MB Motor Brake Module Sizes 50 and 180

Component Parts

Item	Description	EM-50		EM-180	
		Part No.	Qty.	Part No.	Qty.
1	Armature Assembly	5370-111-022	1	5370-111-013	1
2	Retaining Ring	748-0445	1	748-0676	1
3	Armature Hub	540-1638	1	540-2038	1
4	Armature Hub Retaining Ring			748-0450	2
5	Retaining Ring	748-2044	1	748-0101	1
6	Ball Bearing	166-0143	1	166-0150	1
7	Magnet Assembly		1		1
	6 Volt	5370-631-201		5370-631-216	
	24 Volt	5370-631-203		5370-631-218	
	90 Volt	5370-631-204		5370-631-219	
8	Housing	535-0206	1	535-0206	1
9	Bushing	572-0522	1	572-0522	1
10	Magnet Mounting Screw	797-0077	4	797-1358	4
11	Key	590-0043	1	590-0084	1
12	Hub	540-2076	1	540-2078	1
13	Retaining Ring	748-0556	1	748-0555	1
14	Cap	248-1004	1	248-1004	1
15	Mounting Accessory	5370-101-081	1	5370-101-081	1
	15-1 Tie Bolt	797-1563	4	797-1563	4
	15-2 Key	590-0029	1	590-0029	1
16	Cover Kit (Optional)	5370-101-082	1	5370-101-082	1
	16-1 Vent Cover	258-1227	2	258-1227	2
	16-2 Screw	797-1562	4	797-1562	4
	16-3 Cover Plate	287-0135	1	287-0135	1
	16-4 Gasket	495-0042	2	495-0042	2

Refer to service manual P-273-5.
These units meet the standards of UL 508 and are listed under guide card #NMTR2, file #59164.



EM Series Electro Module

Original Design – 20MB Motor Brake Module

Sizes 50, 180 and 210

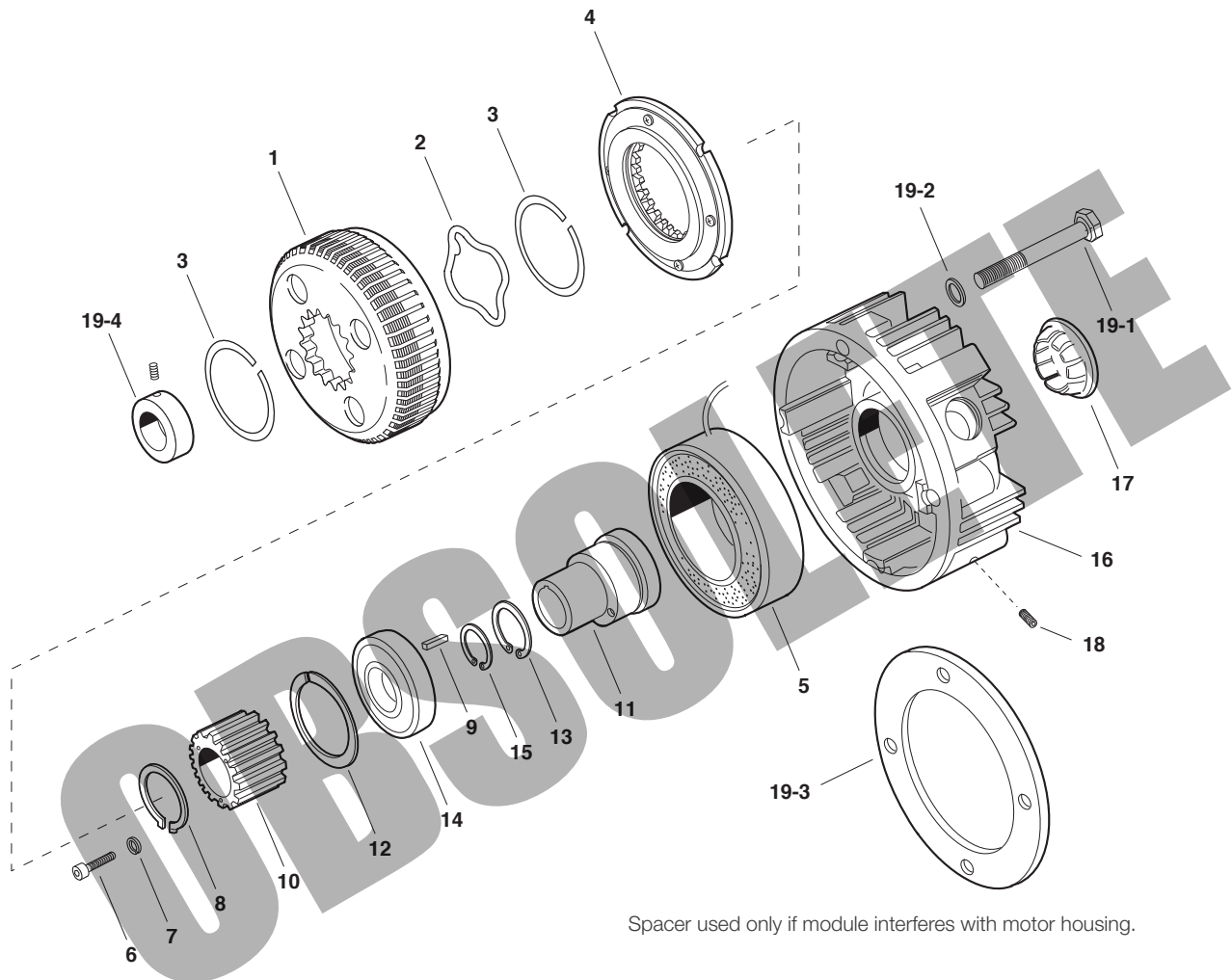

Service Parts

EM Series Electro Module

Original Design – 20MB Motor Brake Module

Sizes 50, 180 and 210

Component Parts (Gray shaded areas indicate original design parts which will be available for a limited time)

Item	Description	EM-50		EM-180		EM-210	
		Part No.	Qty.	Part No.	Qty.	Part No.	Qty.
1	Fan Assembly	5370-104-002	1	5370-104-001	1	748-1052	1
2	Follow-up Spring	808-0104	1	808-0107	1	808-0109	1
3	Retaining Ring	748-0440	2	748-0450	2	748-0455	2
4	Armature	5370-111-011	1	5370-111-013	1	5371-111-005	1
5	Magnet		1		1		1
	6 Volt	5370-631-008		5370-631-002		5371-631-002	
	24 Volt	5370-631-010		5370-631-005		5371-631-005	
	90 Volt	5370-631-007		5370-631-003		5371-631-003	
6	Capscrew					797-0081	6
7	Lockwasher					950-0372	6
8	Retaining Ring	748-0445	1				
9	Key	590-0043	1	590-0084	1		
10	Splined Hub	540-1646	1	540-1647	1	540-2041	1
11	Hub	540-1018	1	540-0726	1	540-1020	1
12	Retaining Ring	748-0113	2	748-0101	1	748-0112	1
13	Retaining Ring			748-0676	1		
14	Bearing	166-0149	1	166-0101	1	166-0142	1
15	Retaining Ring	748-0556	1	748-0555	1	748-0554	1
16	Housing	535-0136	1	535-0134	1	535-0050	1
17	Plug	680-0028	1	680-0028	1	680-0027	1
18	Setscrew	797-0471	4	797-0471	4	797-0103	4
19	Mounting Accessory	5370-101-017	1	5370-101-023	1	5371-101-007	1
	19-1 Capscrew	797-0353	4	797-0353	4	797-1081	4
	19-2 Lockwasher	950-0354	4	950-0354	4	950-0033	4
	19-3 Spacer			807-0218	1		
	19-4 Collar			266-0002	1	266-0003	1
	Key Accessory - Input	5370-101-073	1	5370-101-073	1	5371-101-043	1

Refer to Service Manual P-213.

These units meet the standards of UL 508 and are listed under guide card #NMTR2, file #59164.



Service Parts

EM Series Electro Module

GEN 2 Design – 30 Motor Clutch Module

Sizes 50, 100 and 180

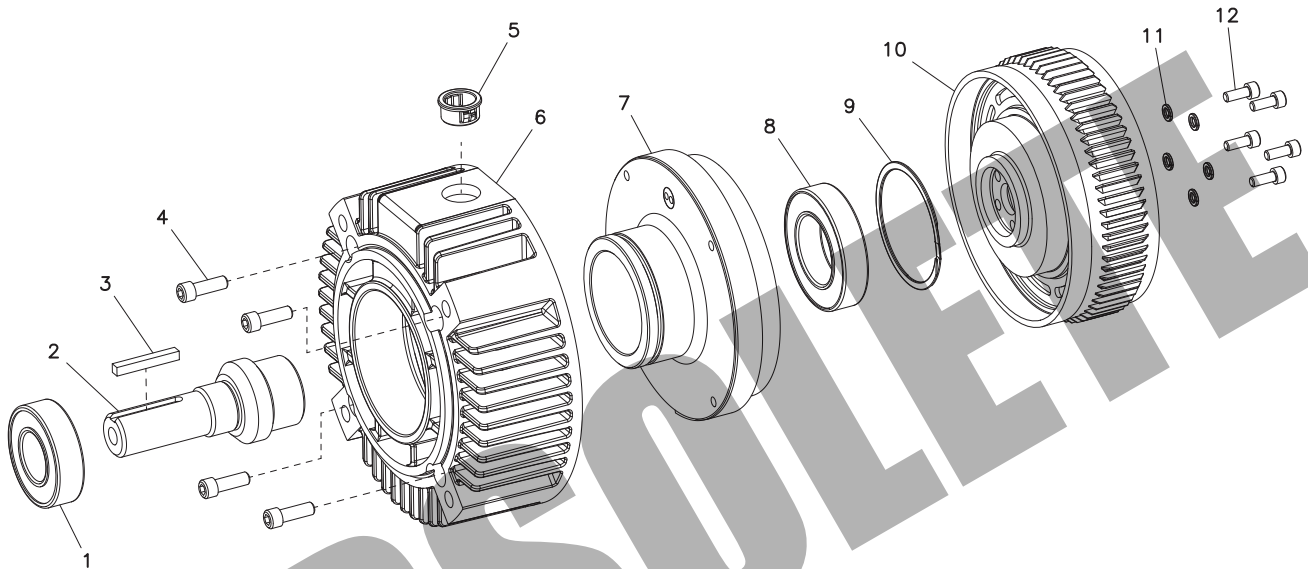

Component Parts

Item	Description	EM-50		EM-100		EM-180	
		Part No.	Qty.	Part No.	Qty.	Part No.	Qty.
1	Ball Bearing	166-0143	1	166-0143	1	166-0143	1
2	Shaft	798-0300	1	798-0303	1	798-0306	1
3	Key	590-0029	1	590-0029	1	590-0029	1
4	Field Mounting Screw	797-0077	4	797-0077	4	797-0077	4
5	Bushing	572-0522	1	572-0522	1	572-0522	1
6	Housing	535-0205	1	535-0205	1	535-0205	1
7	Field Assembly		1		1		1
	6 Volt	5370-451-211		5370-451-216		5370-451-216	
	24 Volt	5370-451-213		5370-451-218		5370-451-218	
	90 Volt	5370-451-214		5370-451-219		5370-451-219	
8	Ball Bearing	166-0143	1	166-0150	1	166-0150	1
9	Retaining Ring	748-2044	1	748-0101	1	748-0101	1
10	Rotor Assembly	5370-751-006	1	5370-751-053	1	5370-751-053	1
11	Washer	950-0436	4	950-0436	5	950-0436	5
12	Screw	797-1294	4	797-1214	5	797-1214	5

Refer to service manual P-273-5.

These units meet the standards of UL 508 and are listed under guide card #NMTR2, file #59164.



Service Parts

EM Series Electro Module

Original Design – 30 Motor Clutch Module

Sizes 50, 100, 180 and 210

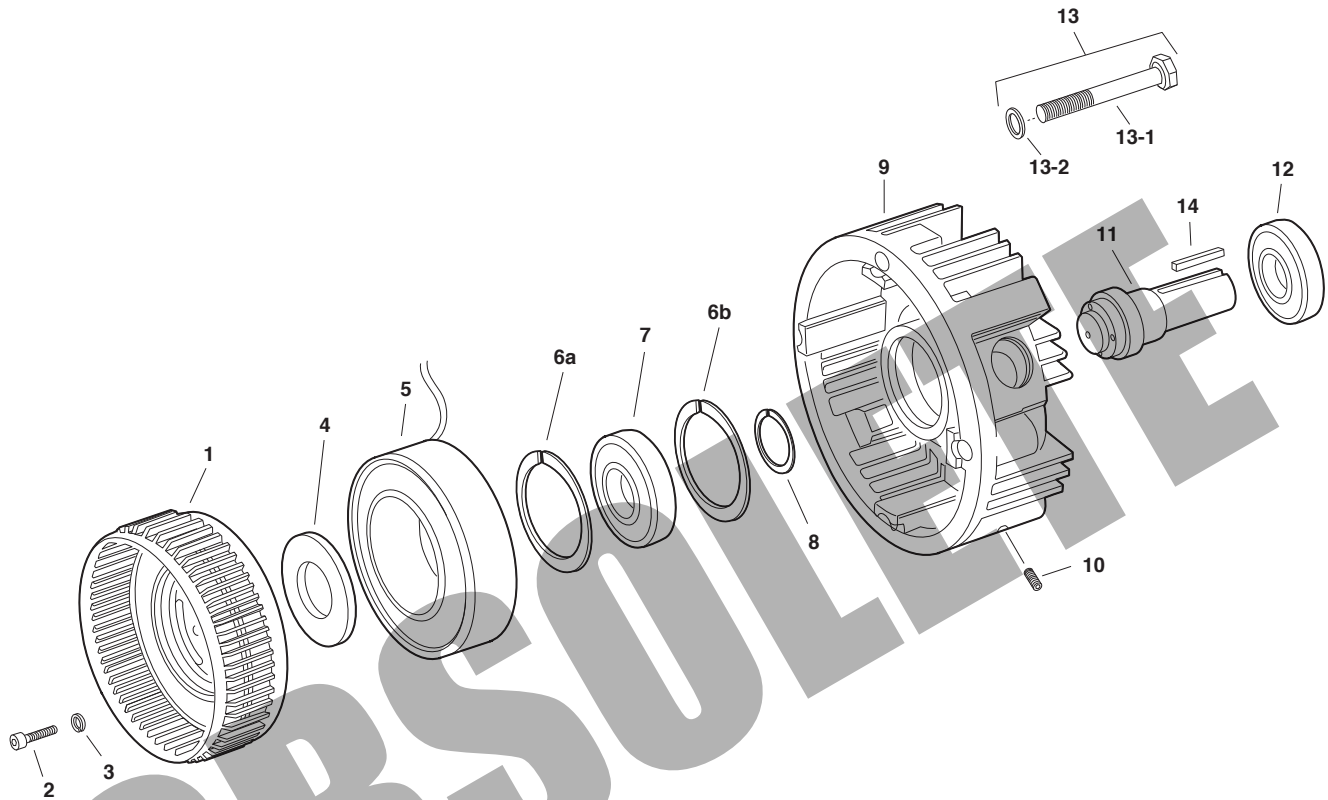

Component Parts (Gray shaded areas indicate original design parts which will be available for a limited time)

Item	Description	EM-50		EM-100		EM-180		EM-210	
		Part No.	Qty.	Part No.	Qty.	Part No.	Qty.	Part No.	Qty.
1	Rotor Assembly w/fan	5370-751-006	1	5370-751-009	1	5370-751-009	1	5371-751-007	1
2	Capscrew	797-1039	4	797-1214	5	797-1214	5	797-0083	6
3	Lockwasher	950-0436	4	950-0436	5	950-0436	5	950-0372	6
4	Spacer			807-0062	1	807-0062	1	807-0061	1
5	Field (with housing EM-50-30 only)		1		1		1		1
	6 volt	5370-451-072		5370-451-007		5370-451-007		5371-451-002	
	24 volt	5370-451-074		5370-451-005		5370-451-005		5371-451-005	
	90 volt	5370-451-073		5370-451-008		5370-451-008		5371-451-003	
6a	Retaining Ring	748-0113	1	748-0101	1	748-0101	1	748-0112	1
6b	Retaining Ring	748-0113	1						
7	Ball Bearing	166-0149	1	166-0101	1	166-0101	1	166-0142	1
8	Retaining Ring	748-0017	1						
9	Housing			535-0164	1	535-0164	1	535-0129	1
10	Setscrew	797-0471	4	797-0471	4	797-0471	4	797-0471	4
11	Shaft	798-0047	1	798-0129	1	798-0124	1	798-0123	1
12	Ball Bearing	166-0155	1	166-0143	1	166-0143	1	166-0144	1
13	Mounting Accessory							5371-101-010	1
	13-1 Capscrew							797-1075	4
	13-2 Lockwasher							950-0032	4
14	Key	590-0029	1	590-0029	1	590-0029	1	590-0019	1

Refer to Service Manual P-213.

These units meet the standards of UL 508 and are listed under guide card #NMTR2, file #59164.



Service Parts

EM Series Electro Module

GEN 2 Design – 40 Output Clutch Module

Sizes 50, 100 and 180

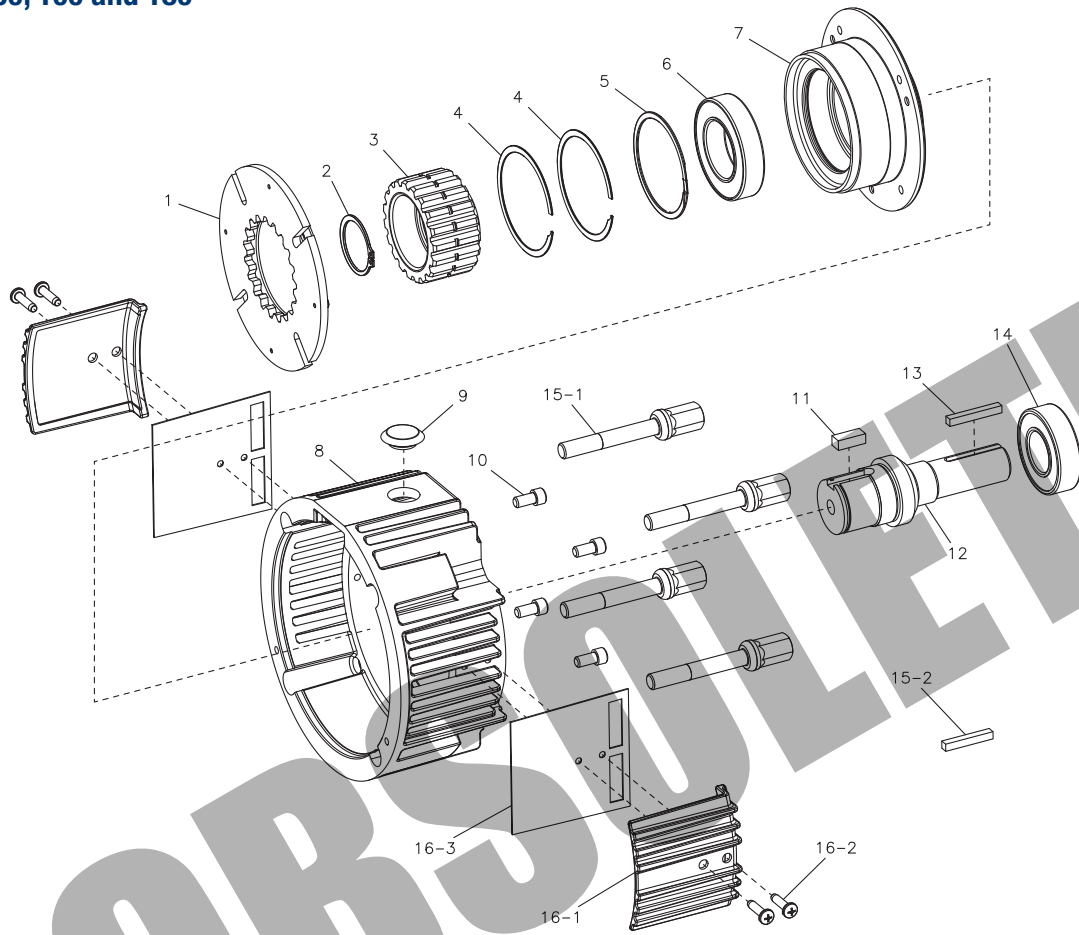

Component Parts

Item	Description	EM-50		EM-100		EM-180	
		Part No.	Qty.	Part No.	Qty.	Part No.	Qty.
1	Armature Assembly	5370-111-022	1	5370-111-013	1	5370-111-013	1
2	Retaining Ring	748-0445	1	748-0676	1	748-0676	1
3	Armature Hub	540-1638	1	540-2038	1	540-2038	1
4	Armature Hub Retaining Ring			748-0450	2	748-0450	2
5	Retaining Ring	748-2044	1	748-0101	1	748-0101	1
6	Ball Bearing	166-0143	1	166-0150	1	166-0150	1
7	Bearing Hub	690-0276	1	690-0278	1	690-0278	1
8	Housing	535-0207	1	535-0207	1	535-0207	1
9	Plug	680-0037	1	680-0037	1	680-0037	1
10	Hub Mounting Screw	797-0077	4	797-1358	4	797-1358	4
11	Key	590-0043	1	590-0084	1	590-0084	1
12	Shaft	798-0298	1	798-0301	1	798-0304	1
13	Key	590-0029	1	590-0029	1	590-0029	1
14	Ball Bearing	166-0143	1	166-0143	1	166-0143	1
15	Mounting Accessory	5370-101-077	1	5370-101-077	1	5370-101-077	1
	15-1 Tie Bolt	825-0013	4	825-0013	4	825-0013	4
	15-2 Key	590-0142	1	590-0142	1	590-0142	1
16	Cover Kit (Optional)	5370-101-076	1	5370-101-076	1	5370-101-076	1
	16-1 Cover	258-1227	2	258-1227	2	258-1227	2
	16-2 Screw	797-1562	4	797-1562	4	797-1562	4
	16-3 Gasket	495-0042	2	495-0042	2	495-0042	2

Refer to service manual P-273-5.

These units meet the standards of UL 508 and are listed under guide card #NMTR2, file #59164.



Service Parts

EM Series Electro Module

Original Design – 40 Output Clutch Module

Sizes 50, 100, 180 and 210

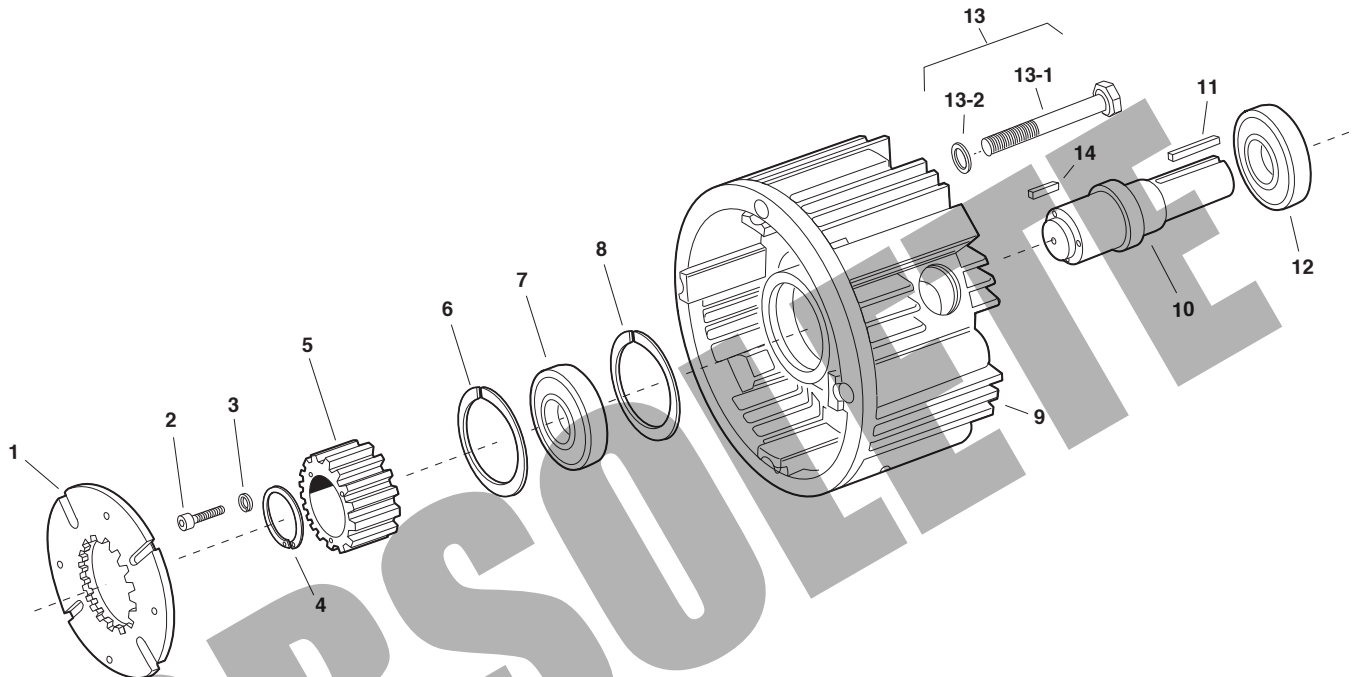

Component Parts (Gray shaded areas indicate original design parts which will be available for a limited time)

Item	Description	EM-50		EM-100		EM-180		EM-210	
		Part No.	Qty.	Part No.	Qty.	Part No.	Qty.	Part No.	Qty.
1	Armature	5370-111-011	1	5370-111-013	1	5370-111-013	1	5371-111-005	1
2	Capscrew							797-0081	1
3	Lockwasher							950-0372	6
4	Retaining Ring	748-0445	1	748-0676	1	748-0676	1		
5	Hub	540-1638	1	540-1642	1	540-1642	1	540-2053	1
6	Retaining Ring	748-0113	1	748-0101	1	748-0101	1	748-0112	1
7	Ball Bearing	166-0149	1	166-0101	1	166-0101	1	166-0142	1
8	Retaining Ring	748-0113	2						
9	Housing	535-0131	1	535-0133	1	535-0133	1	535-0034	1
10	Shaft	798-0046	1	798-0128	1	798-0085	1	798-0051	1
11	Key	590-0029	1	590-0029	1	590-0029	1	590-0019	1
12	Ball Bearing	166-0155	1	166-0143	1	166-0143	1	166-0144	1
13	Mounting Accessory	5370-101-017	1	5370-101-017	1	5370-101-017	1		
	13-1 Capscrew	797-0353	4	797-0353	4	797-0353	4		
	13-2 Lockwasher	950-0354	4	950-0354	4	950-0354	4		
14	Key	590-0043	1	590-0084	1	590-0084	1		
	Key Accessory - Input	5370-101-072	1	5370-101-072	1	5370-101-072	1	5371-101-043	1

Refer to Service Manual P-213.

These units meet the standards of UL 508 and are listed under guide card #NMTR2, file #59164.



Service Parts

EUM/EUM-W Series Electro Module

EUM-1020 Clutch/Brake Combination

EUM-W-1020 Clutch/Brake Combination

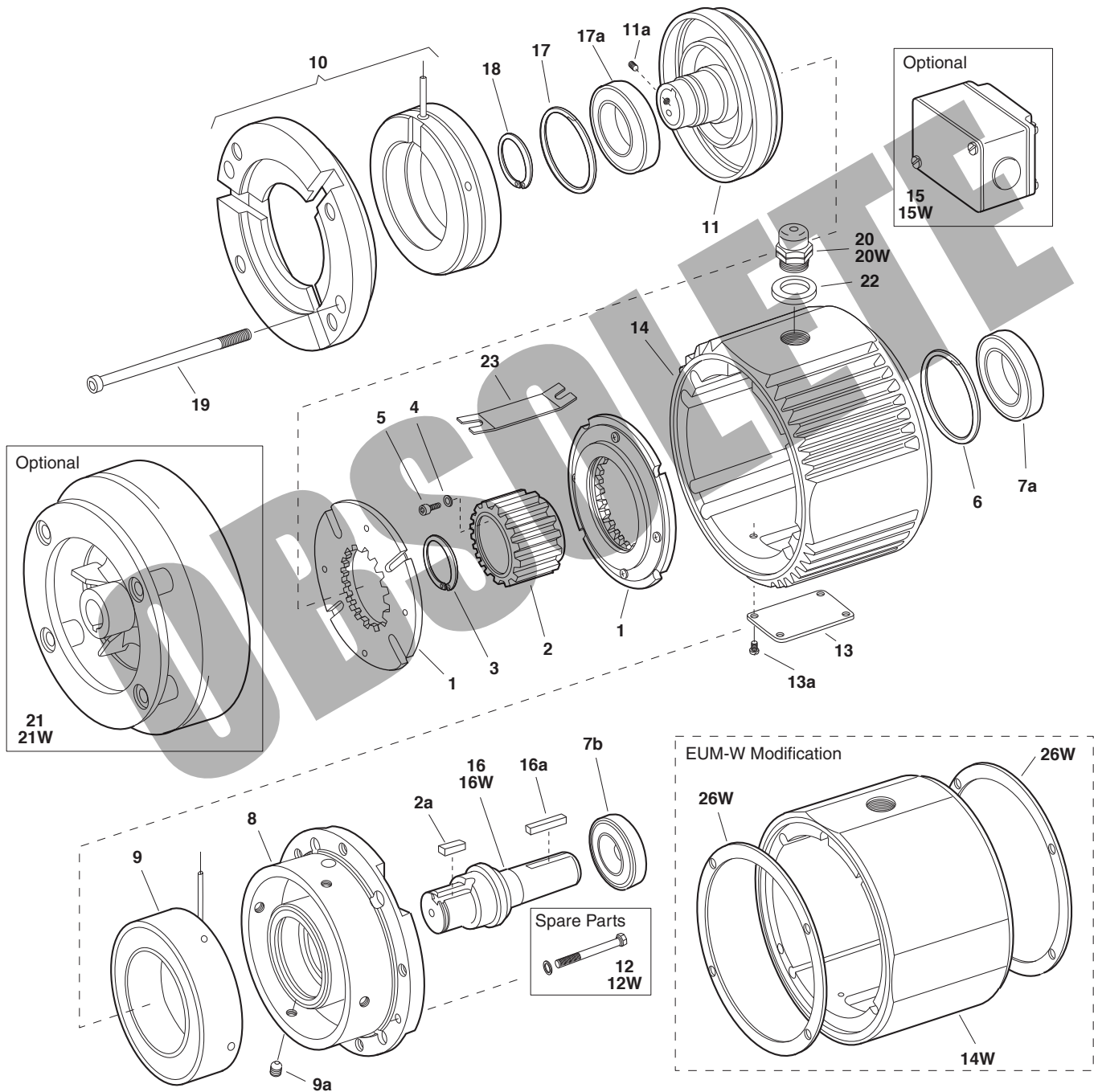

Service Parts

EUM/EUM-W Series Electro Module

EUM-1020 Clutch/Brake Combination EUM-W-1020 Clutch/Brake Combination

Component Parts

Item	Description	EUM-50		EUM-100		EUM-180		EUM-210		EUM-215	
		Part No.	Qty.	Part No.	Qty.	Part No.	Qty.	Part No.	Qty.	Part No.	Qty.
1	Armature Assembly	5370-111-011	2	5370-111-013	2	5370-111-013	2	5371-111-005	2	5371-111-005	2
2	Armature Hub	540-1638	1	540-1642	1	540-1642	1	540-2053	1	540-2053	1
2a	Key	590-0043	1	590-0084	1	590-0084	1				
3	Retaining Ring	748-0445	1	748-0676	1	748-0676	1				
4	Lockwasher							950-0121	6	950-0121	6
5	Capscrew							797-0081	6	797-0081	6
6	Retaining Ring	748-0113	2	748-0101	1	748-0101	1	748-0112	1	748-0112	1
7a	Ball Bearing	166-0149	1	166-0101	1	166-0101	1	166-0142	1	166-0142	1
7b	Ball Bearing	166-0155	1	166-0143	1	166-0143	1	166-0144	1	166-0144	1
8	Endbell/Brake	456-1014	1	456-1019	1	456-1019	1	456-1017	1	456-1017	1
9	Brake Magnet		1		1		1		1		1
	6 volt	5370-631-037		5370-631-002		5370-631-002		5371-631-002		5371-631-002	
	24 volt	5370-631-038		5370-631-005		5370-631-005		5371-631-005		5371-631-005	
9a	90 volt	5370-631-036		5370-631-003		5370-631-003		5371-631-003		5371-631-003	
	Set Screws	797-0471	4	797-0471	4	797-0471	4	797-0471	4	797-0471	4
10	Clutch Field/Endbell Assembly		1		1		1		1		1
	6 volt	5370-451-077		5370-451-086		5370-451-086		5371-451-033		5371-451-033	
	24 volt	5370-451-078		5370-451-087		5370-451-087		5371-451-034		5371-451-034	
	90 volt	5370-451-076		5370-451-085		5370-451-085		5371-451-032		5371-451-032	
11	Rotor/Hub Assembly	5370-751-023	1	5370-751-035	1	5370-751-024	1	5371-751-014	1	5371-751-033	1
11a	Set Screws	797-1098	2	797-0069	2	797-0069	2	797-1098	2	797-1098	2
12	Mounting Accessory Kit							5371-101-024	1	5371-101-024	1
13	Cover Plate	686-1055	1	686-1055	1	686-1055	1	686-1055	1	686-1055	1
13a	Cover Plate Screws	797-0575	4	797-0575	4	797-0575	4	797-0575	4	797-0575	4
14	Center Housing							535-0177	1	535-0177	1
15	Conduit Box (optional)							5370-101-042	1	5370-101-042	1
16	Shaft							798-0051	1	798-0254	1
16a	Key	590-0029	1	590-0029	1	590-0029	1	590-0019	1	590-0124	1
17	Retaining Ring	748-0101	2	748-0101	1	748-0101	1	748-0558	1	748-0558	1
17a	Ball Bearing	166-0150	1	166-0300	1	166-0300	1	166-0168	1	166-0168	1
18	Retaining Ring	748-0018	1	748-0018	1	748-0018	1	748-0067	1	748-0067	1
19	Assembly Bolts	797-1433	2	797-1433	2	797-1433	2	797-1438	2	797-1438	2
20	Connector							280-0038	1	280-0038	1
21	Accessory Fan (optional)							5371-101-029	1	N/A	
22	Washer	950-0441	1	950-0441	1	950-0441	1	950-0441	1	950-0441	1
23	Insulator	572-0327	1	572-0327	1	572-0327	1	572-0327	1	572-0327	1
EUM-W Unique Parts											
12W	Washdown Mounting Kit	5370-101-052	1	5370-101-052	1	5370-101-052	1	5371-101-028	1	5371-101-028	1
14W	Center Housing for Washdown	535-0181	1	535-0181	1	535-0181	1	535-0182	1	535-0182	1
15W	Conduit Box Kit	5370-101-045	1	5370-101-045	1	5370-101-045	1	5370-101-045	1	5370-101-045	1
16W	Shaft	798-0263	1	798-0265	1	798-0262	1	798-0259	1	798-0267	1
20W	Conduit Connector	280-0058	1	280-0058	1	280-0058	1	280-0058	1	280-0058	1
21W	Fan Kit (optional)	5370-101-060	1	5370-101-060	1	5370-101-061	1	5371-101-033	1	N/A	
26W	Gasket/Seal Repair Kit	5370-101-058	1	5370-101-058	1	5370-101-058	1	5371-101-032	1	5371-101-032	1
	Key	5370-101-072	1	5370-101-072	1	5370-101-072	1	5371-101-043	1	5371-101-044	1

Refer to Service Manual P-213.

These units meet the standards of UL 508 and are listed under guide card #NMTR 2, file #59164.



Service Parts

EUM Series Electro Module

EUM-1040 Clutch Combination

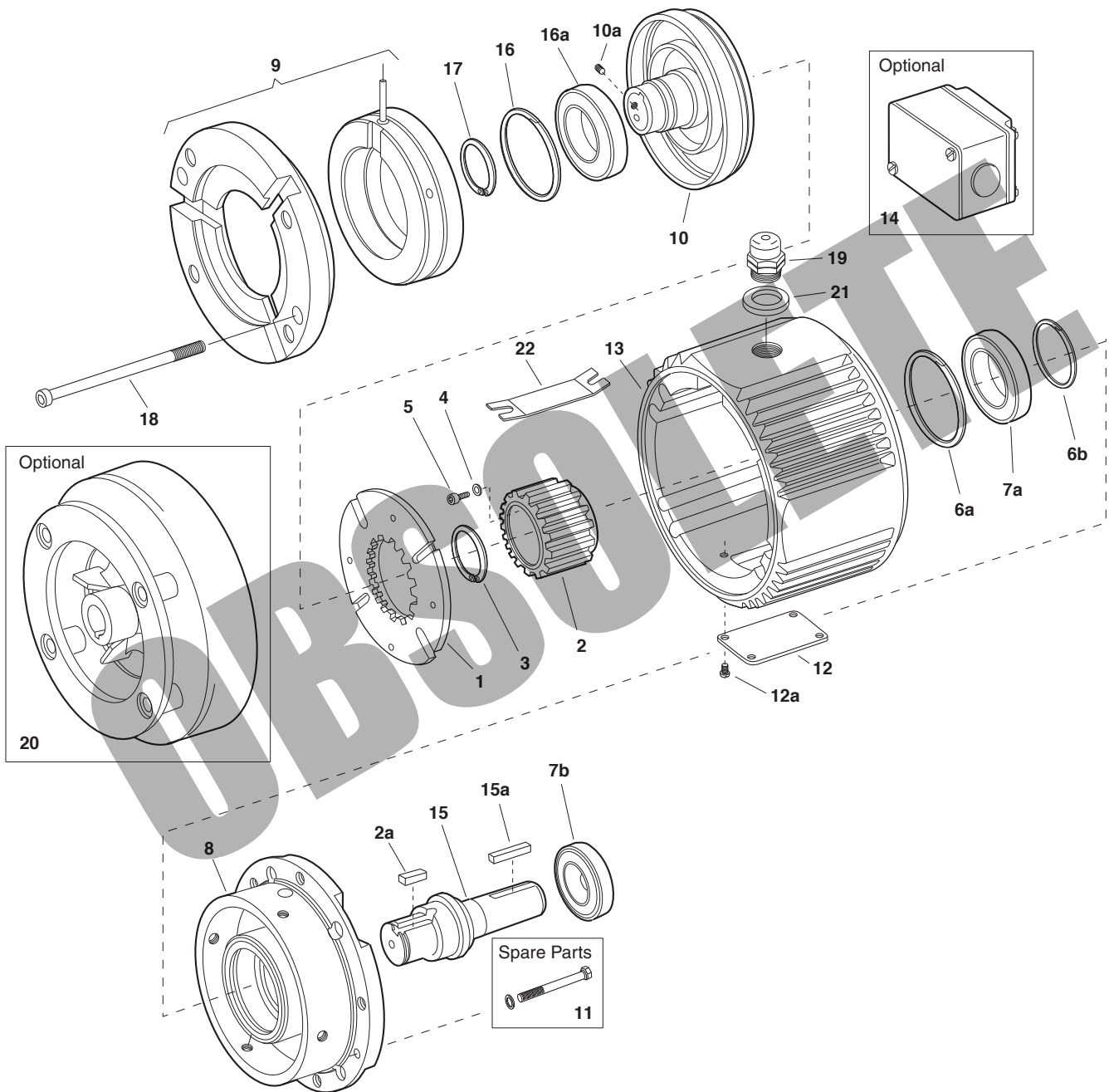

Service Parts

EUM Series Electro Module

EUM-1040 Clutch Combination

Component Parts

Item	Description	EUM-50		EUM-180		EUM-210	
		Part No.	Qty.	Part No.	Qty.	Part No.	Qty.
1	Armature Assembly	5370-111-011	1	5370-111-013	1	5371-111-005	1
2	Armature Hub	540-1638	1	540-1642	1	540-2053	1
2a	Key	590-0043	1	590-0084	1		
3	Retaining Ring	748-0445	1	748-0676	1		
4	Lockwasher					950-0121	6
5	Capscrew					797-0081	6
6a	Retaining Ring	748-0113	1	748-0101	1	748-0112	1
6b	Retaining Ring	748-0113	1				
7a	Ball Bearing	166-0149	1	166-0101	1	166-0142	1
7b	Ball Bearing	166-0155	1	166-0143	1	166-0144	1
8	Endbell	456-1014	1	456-1019	1	456-1017	1
9	Clutch Field/Endbell Assembly 90 Volt	5370-451-076	1	5370-451-085	1	5371-451-032	1
10	Rotor/Hub Assembly	5370-751-023	1	5370-751-024	1	5371-751-014	1
10a	Set Screws	797-1098	2	797-0069	2	797-1098	2
11	Mounting Accessory Kit	5370-101-040	1	5370-101-040	1	5371-101-024	1
12	Cover Plate	686-1055	1	686-1055	1	686-1055	1
12a	Cover Plate Screws	797-0575	4	797-0575	4	797-0575	4
13	Center Housing	535-0176	1	535-0176	1	535-0177	1
14	Conduit Box (optional)	5370-101-042	1	5370-101-042	1	5370-101-042	1
15	Shaft	798-0046	1	798-0085	1	798-0051	1
15a	Key	590-0029	1	590-0029	1	590-0019	1
16	Retaining Ring	748-0101	2	748-0101	1	748-0558	1
16a	Ball Bearing	166-0150	1	166-0300	1	166-0168	1
17	Retaining Ring	748-0018	1	748-0018	1	748-0067	1
18	Assembly Bolts	797-1433	2	797-1433	2	797-1438	2
19	Connector	280-0038	1	280-0038	1	280-0038	1
20	Accessory Fan (optional)	5370-101-055	1	5370-101-054	1	5371-101-029	1
21	Washer	950-0441	1	950-0441	1	950-0441	1
22	Insulator	572-0327	1	572-0327	1	572-0327	1
	Key Accessory	5370-101-072	1	5370-101-072	1	5371-101-043	1

Refer to Service Manual P-213.

These units meet the standards of UL 508 and are listed under guide card #NMTR 2, file #59164.



Service Parts

EUM/EUM-W Series Electro Module

EUM-2030 Clutch/Brake Combination

EUM-W-2030 Clutch/Brake Combination

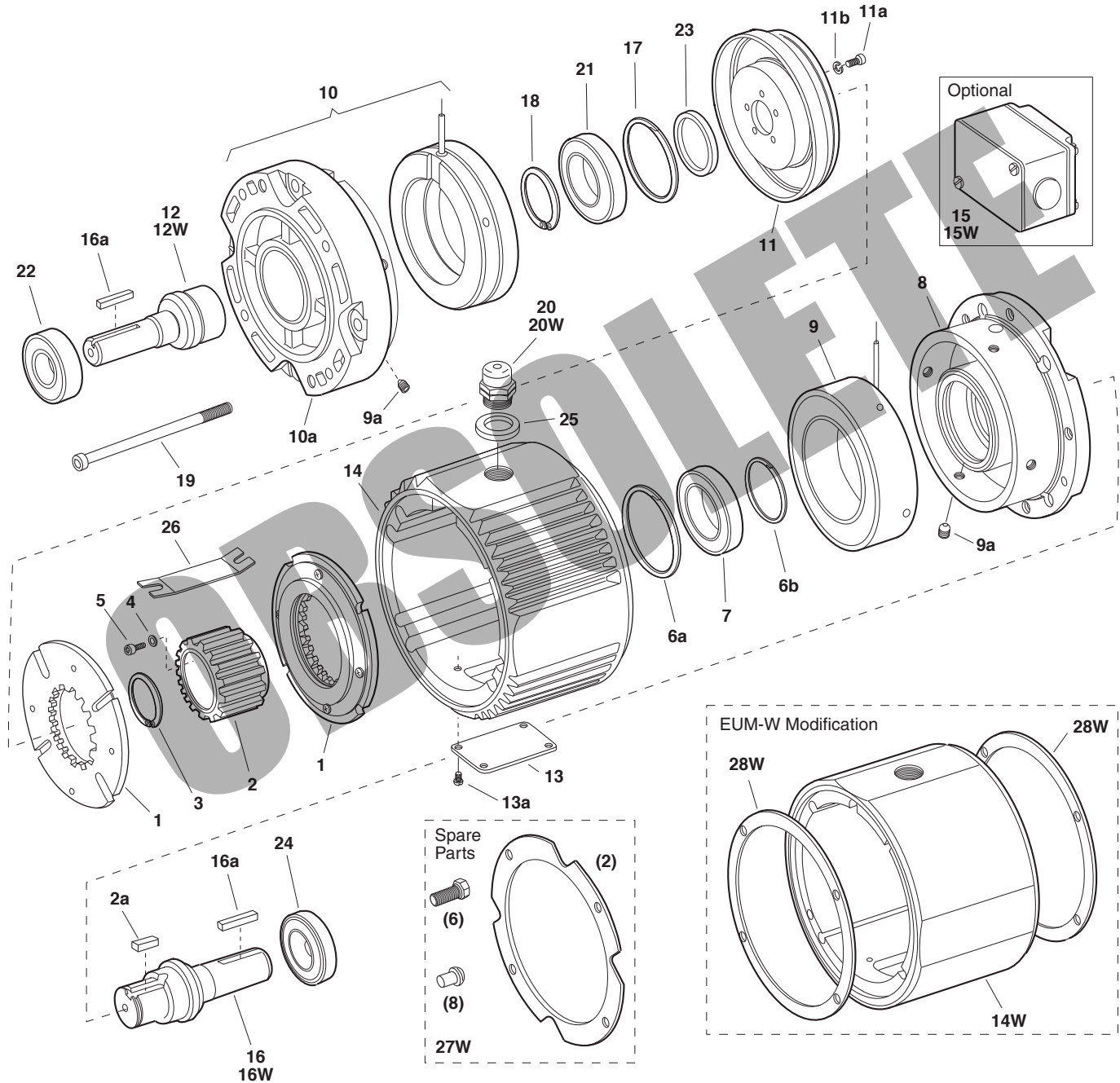

Service Parts

EUM/EUM-W Series Electro Module

EUM-2030 Clutch/Brake Combination EUM-W-2030 Clutch/Brake Combination

Component Parts

Item	Description	EUM-50		EUM-180		EUM-210	
		Part No.	Qty.	Part No.	Qty.	Part No.	Qty.
1	Armature Assembly	5370-111-011	2	5370-111-013	2	5371-111-005	2
2	Armature Hub	540-1638	1	540-1642	1	540-2053	1
2a	Key	590-0043	1	590-0084	1		
3	Retaining Ring	748-0445	1	748-0676	1		
4	Lockwasher					950-0121	6
5	Capscrew					797-0081	6
6a	Retaining Ring	748-0113	2	748-0101	1	748-0112	1
6b	Retaining Ring					748-2002	1
7	Ball Bearing	166-0149	1	166-0101	1	166-0142	1
8	Endbell/Brake	456-1014	1	456-1019	1	456-1017	1
9	Brake Magnet		1		1		1
	6 volt	5370-631-037		5370-631-002		5371-631-002	
	24 volt	5370-631-038		5370-631-005		5371-631-005	
	90 volt	5370-631-036		5370-631-003		5371-631-003	
9a	Set Screws	797-0471	4	797-0471	4	797-0471	8
10	Field (with Endbell EUM-50 and EUM-180)		1		1		1
	6 volt	5370-451-082		5370-451-090		5371-451-002	
	24 volt	5370-451-083		5370-451-091		5371-451-005	
	90 volt	5370-451-081		5370-451-089		5371-451-003	
10a	Endbell (EUM-210 only)					456-1018	1
11	Rotor	5370-751-033	1	5370-751-034	1	5371-751-006	1
11a	Screw	797-1294	4	797-1214	5	797-0081	6
11b	Washer	950-0102	4	950-0102	5	950-0121	6
12	Shaft/Clutch					798-0123	1
13	Cover Plate	686-1055	1	686-1055	1	686-1055	1
13a	Screws	797-0575	4	797-0575	4	797-0575	4
14	Center Housing					535-0177	1
15	Conduit Box (optional)					5370-101-042	1
16	Shaft/Brake					798-0051	1
16a	Key	590-0029	2	590-0029	2	590-0019	2
17	Retaining Ring	748-0113	2	748-0101	1	748-0112	1
18	Retaining Ring	748-0017	1			748-0202	1
19	Assembly Bolts	797-1477	2	797-1477	2	797-1476	2
20	Connector					280-0038	1
21	Bearing	166-0149	1	166-0101	1	166-0142	1
22	Bearing	166-0155	1	166-0143	1	166-0144	1
23	Spacer			807-0062	1	807-0061	1
24	Bearing	166-0155	1	166-0143	1	166-0144	1
25	Washer	950-0441	1	950-0441	1	950-0441	1
26	Insulator	572-0327	1	572-0327	1	572-0327	1
EUM-W Unique Parts							
12W	Shaft/Clutch	798-0264	1	798-0261	1	798-0260	1
14W	Center Housing for Washdown	535-0181	1	535-0181	1	535-0182	1
15W	Conduit Box Kit (optional)	5370-101-045	1	5370-101-045	1	5370-101-045	1
16W	Shaft/Brake	798-0263	1	798-0262	1	798-0259	1
20W	Conduit Connector	280-0058	1	280-0058	1	280-0058	1
27W	Washdown Mounting Kit	5370-101-051	1	5370-101-051	1	5371-101-027	1
28W	Gasket/Seal Repair Kit	5370-101-058	1	5370-101-058	1	5371-101-032	1

Refer to Service Manual P-213.
These units meet the standards of UL 508 and are listed under guide card #NMTR 2, file #59164.



Service Parts

UM Series Smooth-Start UniModules

UM-1020-LK Clutch/Brake Combination

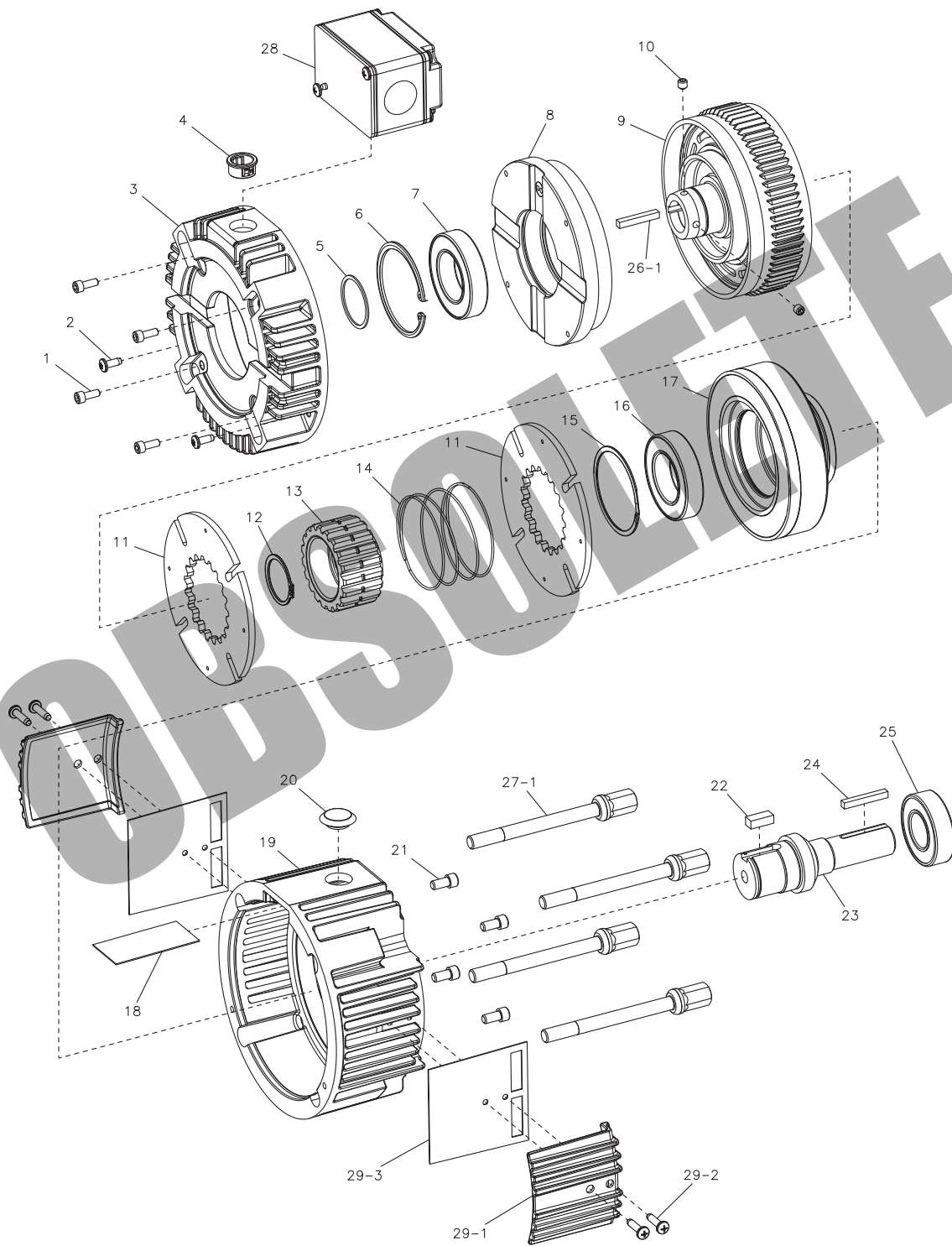

Service Parts

UM Series Smooth-Start UniModules

UM-1020-LK Clutch/Brake Combination

Component Parts

Item	Description	UM-50		UM-100		UM-180	
		Part No.	Qty.	Part No.	Qty.	Part No.	Qty.
1	Field Mounting Screw	797-1214	4	797-1214	4	797-1214	4
2	Screw	797-1568	2	797-1568	2	797-1568	2
3	Housing	535-0204	1	535-0204	1	535-0204	1
4	Bushing	572-0522	1	572-0522	1	572-0522	1
5	Retaining Ring	748-0018	1	748-0018	1	748-0018	1
6	Retaining Ring	748-0561	1	748-0561	1	748-0561	1
7	Ball Bearing	166-0150	1	166-0150	1	166-0150	1
8	Field Assembly 90 Volt	5370-451-204	1	5370-451-209	1	5370-451-209	1
9	Rotor Assembly	5370-751-046	1	5370-751-050	1	5370-751-051	1
10	Set Screw	797-1098	2	797-0069	2	797-0069	2
11	Armature	110-0067	2	110-0075	2	110-0075	2
12	Retaining Ring	748-0445	1	748-0676	1	748-0676	1
13	Armature Hub	540-1638	1	540-2038	1	540-2038	1
14	Spring	808-0449	1	808-0450	1	808-0450	1
15	Retaining Ring	748-2044	1	748-0101	1	748-0101	1
16	Ball Bearing	166-0143	1	166-0150	1	166-0150	1
17	Magnet Assembly 90 Volt	5370-631-214	1	5370-631-229	1	5370-631-229	1
18	Insulator	572-1029	1	572-1029	1	572-1029	1
19	Housing	535-0206	1	535-0206	1	535-0206	1
20	Plug	680-0037	1	680-0037	1	680-0037	1
21	Magnet Mounting Screw	797-0077	4	797-1358	4	797-1358	4
22	Key	590-0043	1	590-0084	1	590-0084	1
23	Shaft	798-0298	1	798-0301	1	798-0304	1
24	Key	590-0029	1	590-0029	1	590-0029	1
25	Ball Bearing	166-0143	1	166-0143	1	166-0143	1
26	Mounting Accessory 26-1 Key	5370-101-072	1	5370-101-072	1	5370-101-072	1
		590-0142	1	590-0142	1	590-0142	1
27	Mounting Accessory 27-1 Tie Bolt	5370-101-075	1	5370-101-075	1	5370-101-075	1
		825-0014	4	825-0014	4	825-0014	4
28	Conduit Box (Optional)	5370-101-042	1	5370-101-042	1	5370-101-042	1
29	Cover Kit (Optional)	5370-101-076	1	5370-101-076	1	5370-101-076	1
	29-1 Cover	258-1227	2	258-1227	2	258-1227	2
	29-2 Screw	797-1562	4	797-1562	4	797-1562	4
	29-3 Gasket	495-0042	2	495-0042	2	495-0042	2

Refer to Service Manual P-213.

These units meet the standards of UL 508 and are listed under guide card #NMTR 2, file #59164.



Service Parts

EC Series Electro Clutch

EC-375, EC-475, EC-650

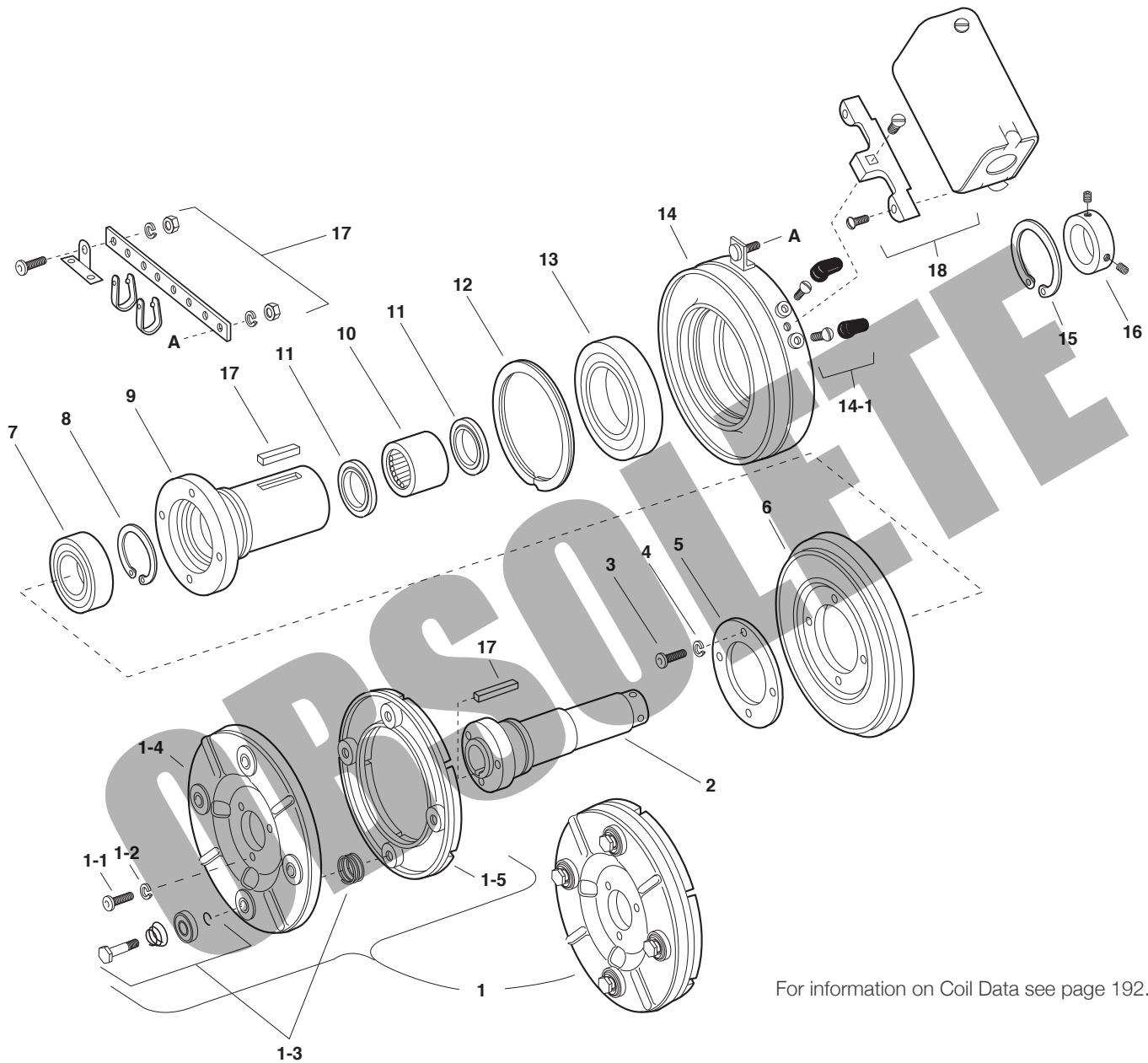

For information on Coil Data see page 192.

Electrical and Mechanical Data

Model Size	Voltage DC	Static Torque (lb. ft.)	Max. Speed RPM	Armature & Carrier	Inertia-WR ² (lb. ft ²)			Total Inner Sleeve	Weight lbs.
					Rotor	Outer Sleeve			
EC-375	6	16 lb. ft.	5000	.010	.018	.001	.001	4	
	24	16 lb. ft.	5000	.010	.018	.001	.001	4	
	90	16 lb. ft.	5000	.010	.018	.001	.001	4	
EC-475	6	30 lb. ft.	4500	.072	.033	.006	.002	8	
	24	30 lb. ft.	4500	.072	.033	.006	.002	8	
	90	30 lb. ft.	4500	.072	.033	.006	.002	8	
EC-650	6	95 lb. ft.	3600	.106	.202	.010	.013	18	
	24	95 lb. ft.	3600	.106	.202	.010	.013	18	
	90	95 lb. ft.	3600	.106	.202	.010	.013	18	

Service Parts

EC Series Electro Clutch

EC-375, EC-475, EC-650

Component Parts

Item	Description	EC-375		EC-475		EC-650	
		Part No.	Qty.	Part No.	Qty.	Part No.	Qty.
1	Armature & Carrier Assembly	5380-101-006	1	5181-101-003	1	5281-101-003	1
	1-1 Capscrew	797-1214	3	797-1214	3	797-0086	3
	1-2 Lockwasher	950-0102	3	950-0102	3	950-0102	3
	1-3 Autogap Accessory	5180-101-011	3	5181-101-010	4	5181-101-010	4
	1-4 Carrier	5380-295-002	1	5181-295-002	1	5281-295-002	1
	1-5 Armature	5180-111-002	1	5181-111-002	1	5281-111-002	1
2	Inner Sleeve		1		1		1
	1/2" Bore	803-0054					
	5/8" Bore	803-0055		803-1007			
	3/4" Bore			803-1005			
	7/8" Bore			803-1006			
	1" Bore					803-0047	
	1-1/8" Bore					803-0049	
	1-1/4" Bore					803-0048	
1-3/8" Bore					803-0050		
3	Screw	797-1050	6	797-1039	4	797-0083	4
4	Lockwasher	950-0105	6	950-0102	4	950-0103	4
5	Retainer Plate	748-0391	1	748-0393	1	748-0389	1
6	Rotor	5180-751-001	1	5181-751-003	1	5281-751-001	1
7	Ball Bearing	166-0149	1	166-2016	2	166-0110	1
8	Retainer ring	748-0017	1	748-0023	2	748-0002	1
9	Outer Sleeve	5180-104-001	1	803-1003	1	5281-104-001	1
10	Sleeve Bearing	166-0177	1	166-0179	1	166-0178	1
11	Oil Seal	795-0027	2	795-0028	2	795-0026	2
12	Retainer Ring	748-0101	1	748-0102	1	748-0104	1
13	Ball Bearing	166-0150	1	166-0110	1	166-0104	1
14	Field		1		1		1
	6 volt	5180-451-002		5181-451-002		5281-451-002	
	24 volt	5180-451-004		5181-451-004		5281-451-004	
	90 volt	5180-451-005		5181-451-005		5281-451-005	
	14-1 Terminal Accessory	5103-101-002	1	5103-101-002	1	5311-101-001	1
15	Retainer Ring	748-0018	1	748-0002	1	748-0004	1
16	Set Collar	266-0011	1	266-0012	1	266-0010	1
17	Accessory, W/Keys		1		1		1
	1/2" Bore	5180-101-001					
	5/8" Bore	5180-101-001		5181-101-001			
	3/4" Bore			5181-101-001			
	7/8" Bore			5181-101-002			
	1" Bore					5281-101-001	
	1-1/8" Bore					5281-101-001	
	1-1/4" Bore					5281-101-001	
1-3/8" Bore					5281-101-002		
18	Conduit Box	5200-101-010	1	5200-101-010	1	5200-101-010	1

These units when used with the correct Warner Electric conduit box, meets the standards of UL508 and are listed under guide care #NMTR, file #59164. Refer to Service Manual P-210.

Note: For EC-475 built prior to 2005, contact Warner Electric for service parts.



Service Parts

EC Series Electro Clutch

EC-825

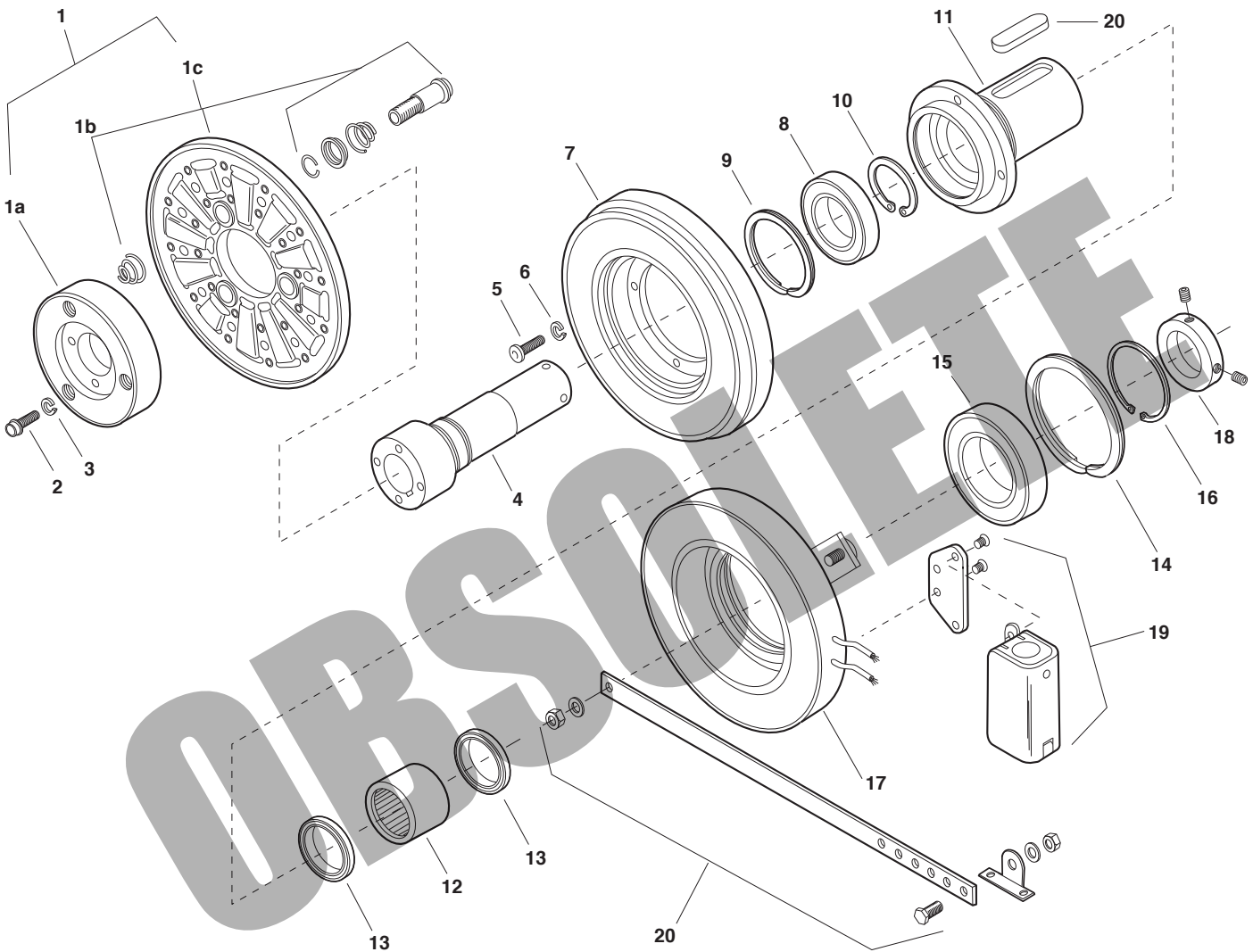

Service Parts

Component Parts

Item	Description	EC-825	
		Part No.	Qty.
1	Armature Assembly	5282-111-002	1
	1a Hub	540-1298	1
	1b Autogap Accessory	5201-101-068	3
	1c Armature	5282-111-001	1
2	Capscrew	797-0081	4
3	Lockwasher	950-0103	4
4	Inner Sleeve		1
	1-1/8" Bore	803-0069	
	1-1/4" Bore	803-0070	
	1-3/8" Bore	803-0071	
5	Capscrew	797-0086	4
6	Lockwasher	950-0103	4
7	Rotor Assembly	5282-751-001	1
8	Ball Bearing	166-0110	1
9	Retainer Ring	748-0102	1
10	Retainer Ring	748-0002	1
11	Rotor Adapter	5282-105-002	1

Item	Description	EC-825	
		Part No.	Qty.
12	Roller Bearing	166-0178	1
13	Oil Seal	795-0026	2
14	Retainer Ring	748-0104	1
15	Ball Bearing	166-0104	1
16	Retainer Ring	748-0004	1
	Field		1
17	6 volt	5282-451-002	
	24 volt	5282-451-004	
	90 volt	5282-451-005	
18	Set Collar	266-0010	1
19	Conduit Box	5200-101-012	1
20	Mounting Accessory with Keys	5282-101-001	1

Refer to Service Manual P-210.
 These units when used with the correct Warner Electric conduit box, meets the standards of UL508 and are listed under guide care #NMTR, file #59164.



OBSOLETE

Service Parts

EC Series Electro Clutch

EC-1000, EC-1225

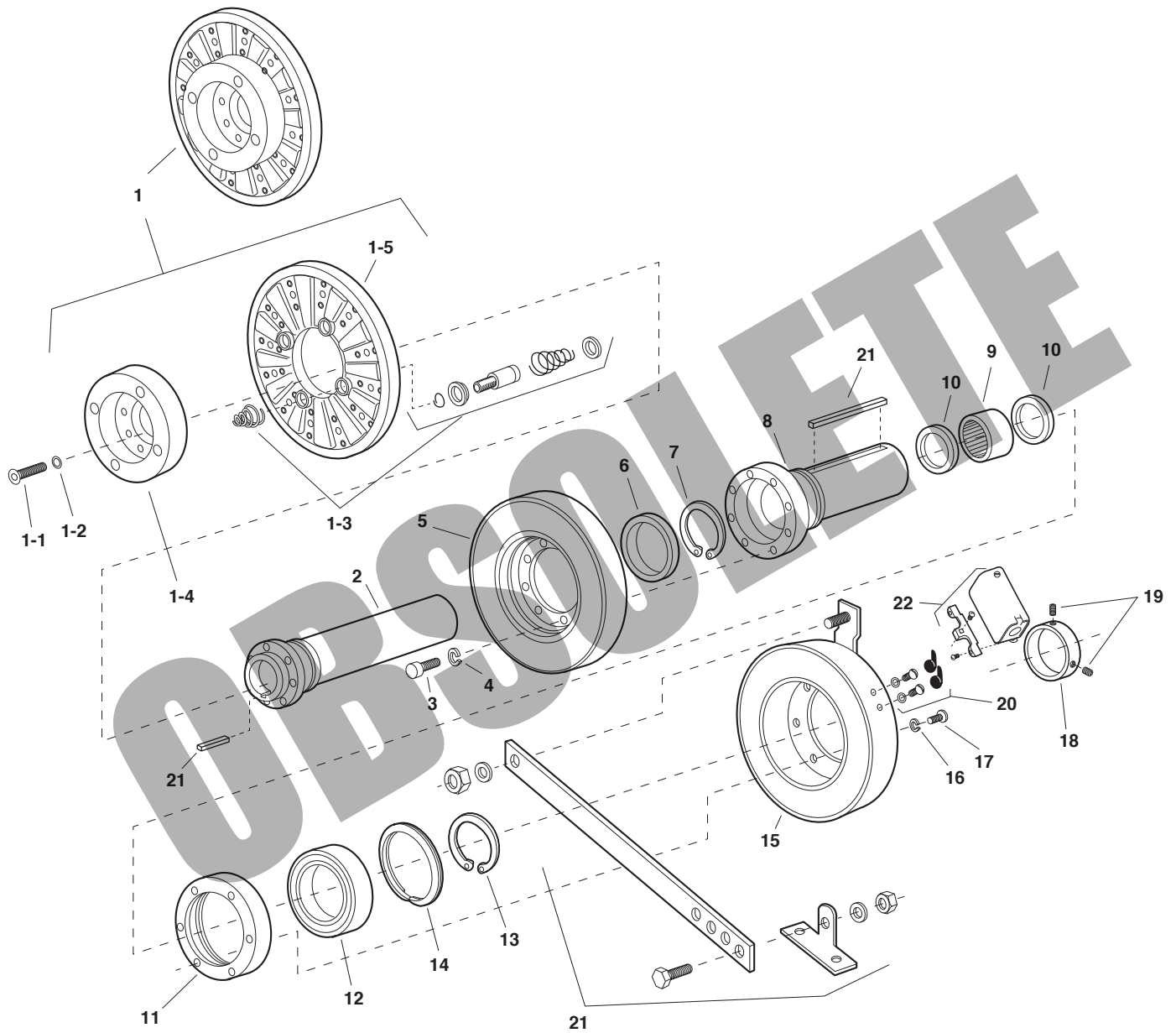

Service Parts

Component Parts

Item	Description	EC-1000		EC-1225	
		Part No.	Qty.	Part No.	Qty.
1	Armature & Carrier Assembly	5283-111-001	1	5284-111-001	1
	1-1 Capscrew	797-1163	6	797-1163	8
	1-2 Lockwasher	950-0111	6	950-0111	8
	1-3 Autogap Accessory	5201-101-008	3	5201-101-008	4
	1-4 Hub	540-1338	1	540-1340	1
	1-5 Armature	5302-111-013	1	5385-111-003	1
2	Inner Sleeve		1		1
	3/8" Bore	803-0027			
	1-1/2" Bore	803-0166			
	1-5/8" Bore	803-0028		803-0078	
	1-5/8" Bore			803-0030	
3	1-7/8" Bore			803-0031	
	2-1/8" Bore				
3	Capscrew	797-0083	8	797-0416	8
4	Lockwasher	950-0103	8	950-0106	8
5	Rotor Assembly	5283-101-002	1	5284-101-006	1
6	Ball Bearing	166-0168	1	166-0170	1
7	Retainer Ring	748-0067	1	748-0503	1
8	Outer Sleeve	803-0025	1	803-0032	1
9	Roller Bearing	166-0180	1	166-0181	1
10	Oil Seal	795-0029	2	795-0033	2
11	Adapter Ring	748-0480	1	748-0466	1
12	Ball Bearing	166-0163	1	166-0163	1
13	Retainer Ring	748-0502	1	748-0502	1
14	Retainer Ring	748-0114	1	748-0114	1
15	Field		1		1
	6 volt	5283-451-002		5284-451-002	
	24 volt	5283-451-010		5284-451-010	
16	90 volt	5283-451-003		5284-451-003	
	Lockwasher	950-0355	6	950-0359	6
17	Capscrew	797-0083	6	797-0416	6
18	Set Collar	266-0015	1	266-0016	1
19	Set Screw	797-0468	2	797-0130	2
20	Terminal Accessory	5311-101-001	1	5311-101-001	1
21	Mounting Accessory with Keys		1		1
	1-3/8" Bore	5283-101-005			
	1-1/2" Bore	5283-101-009		5284-101-007	
	1-5/8" Bore	5283-101-006		5284-101-001	
	1-7/8" Bore			5284-101-002	
22	2-1/8" Bore				
22	Conduit Box	5200-101-011	1	5200-101-011	1

Refer to Service Manual P-210.

These units when used with the correct Warner Electric conduit box, meets the standards of UL508 and are listed under guide care #NMTR, file #59164.



Service Parts

EB Series Electro Brake

EB-375, EB-475, EB-650

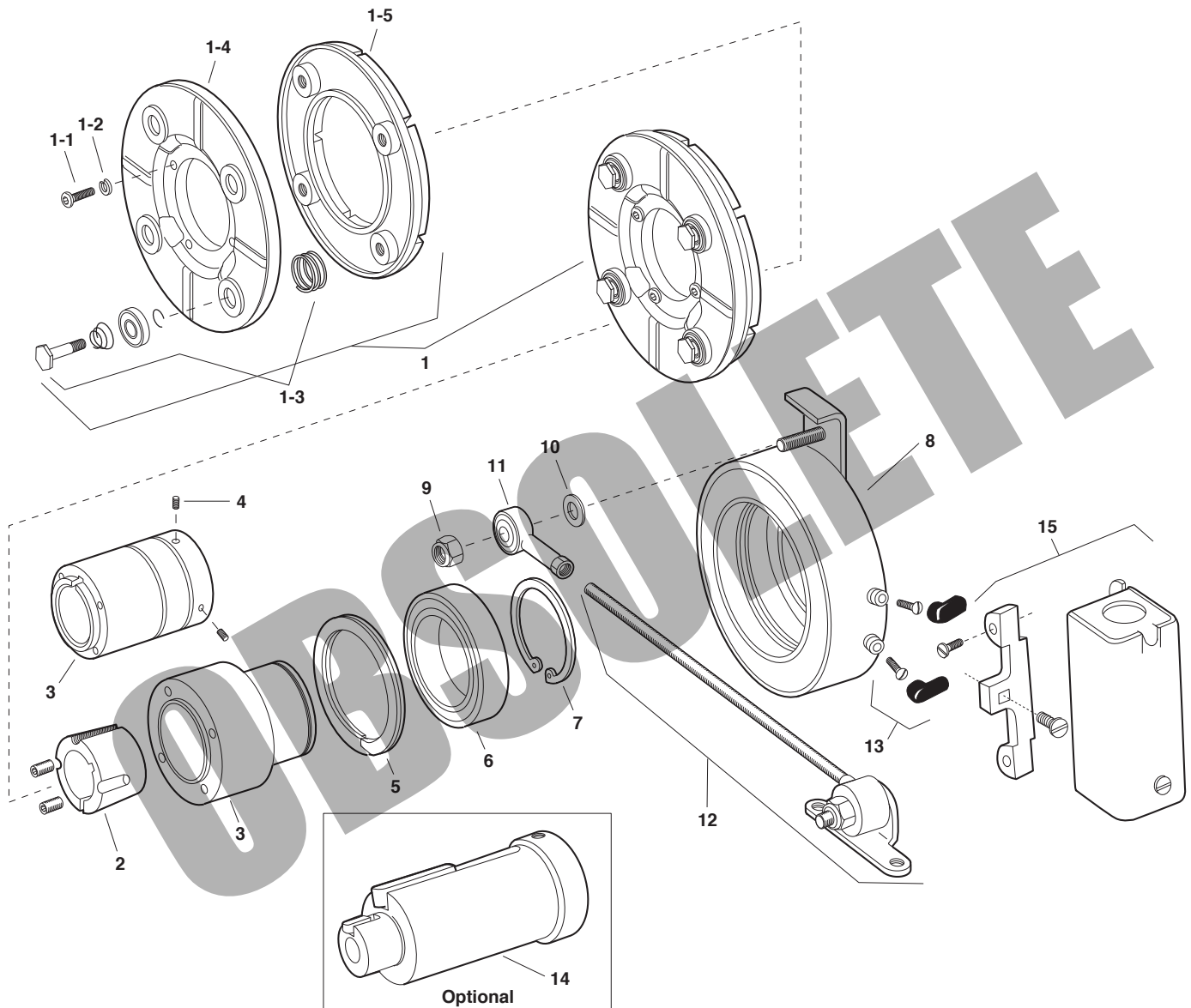

Service Parts

EB Series Electro Brake

EB-375, EB-475, EB-650

Component Parts

Item	Description	EB-375		EB-475		EB-650	
		Part No.	Qty.	Part No.	Qty.	Part No.	Qty.
1	Armature & Carrier Assembly	5380-101-006	1	5381-101-004	1	5382-101-005	1
	1-1 Capscrew	797-1214	3	797-1214	4	797-0086	4
	1-2 Lockwasher	950-0102	3	950-0102	4	950-0103	4
	1-3 Autogap Accessory	5180-101-011	3	5181-101-010	4	5181-101-010	4
	1-4 Carrier	5380-295-002	1	5381-295-003	1	5382-295-002	1
	1-5 Armature	5180-111-002	1	5181-111-002	1	5281-111-002	1
2	*Bushing			180-0410-180-0418 1/2" to 1" bore	1	180-0421-180-0435 1/2" to 1-3/8" bore	1
3	Hub		1	540-0524	1	540-0523	1
	1/2" Bore	540-0520					
	5/8" Bore	540-0519					
4	Set Screw		2				
	1/2" Bore	797-0368					
	5/8" Bore	797-0366					
5	Retainer Ring	748-0101	1	748-0102	1	748-0104	1
6	Ball Bearing	166-0150	1	166-0110	1	166-0104	1
7	Retainer Ring	748-0018	1	748-0002	1	748-0004	1
8	Magnet		1		1		1
	6 volt	5380-631-003		5381-631-003		5382-631-003	
	24 volt	5380-631-004		5381-631-004		5382-631-005	
	90 volt	5380-631-002		5381-631-002		5382-631-002	
9	Locknut	661-0050	1	661-0051	1	661-0004	1
10	Washer	950-0029	1	950-0026	1	950-0030	1
11	Rod End Bearing	166-0186	1	166-0187	1	166-0188	1
12	Torque Arm Rod Assembly	5380-112-001	1	5381-112-001	1	5382-112-001	1
13	Terminal Accessory	5311-101-001	1	5311-101-001	1	5311-101-001	1
14	Adapter (optional)		1		1		1
	5/8" Motor Shaft	5380-101-005					
	7/8" Motor Shaft	5380-101-004					
	1-1/8" Motor Shaft			5381-101-003			
	1-3/8" Motor Shaft					5382-101-003	
	1-5/8" Motor Shaft					5382-101-002	
15	Conduit Box	5200-101-010	1	5200-101-010	1	5200-101-010	1

*See page 198 for specific part numbers.
Refer to Service Manual P-211.

These units when used with the correct Warner Electric conduit box, meets the standards of UL508 and are listed under guide care #NMTR, file #59164.



Service Parts

EB Series Electro Brake

EB-825

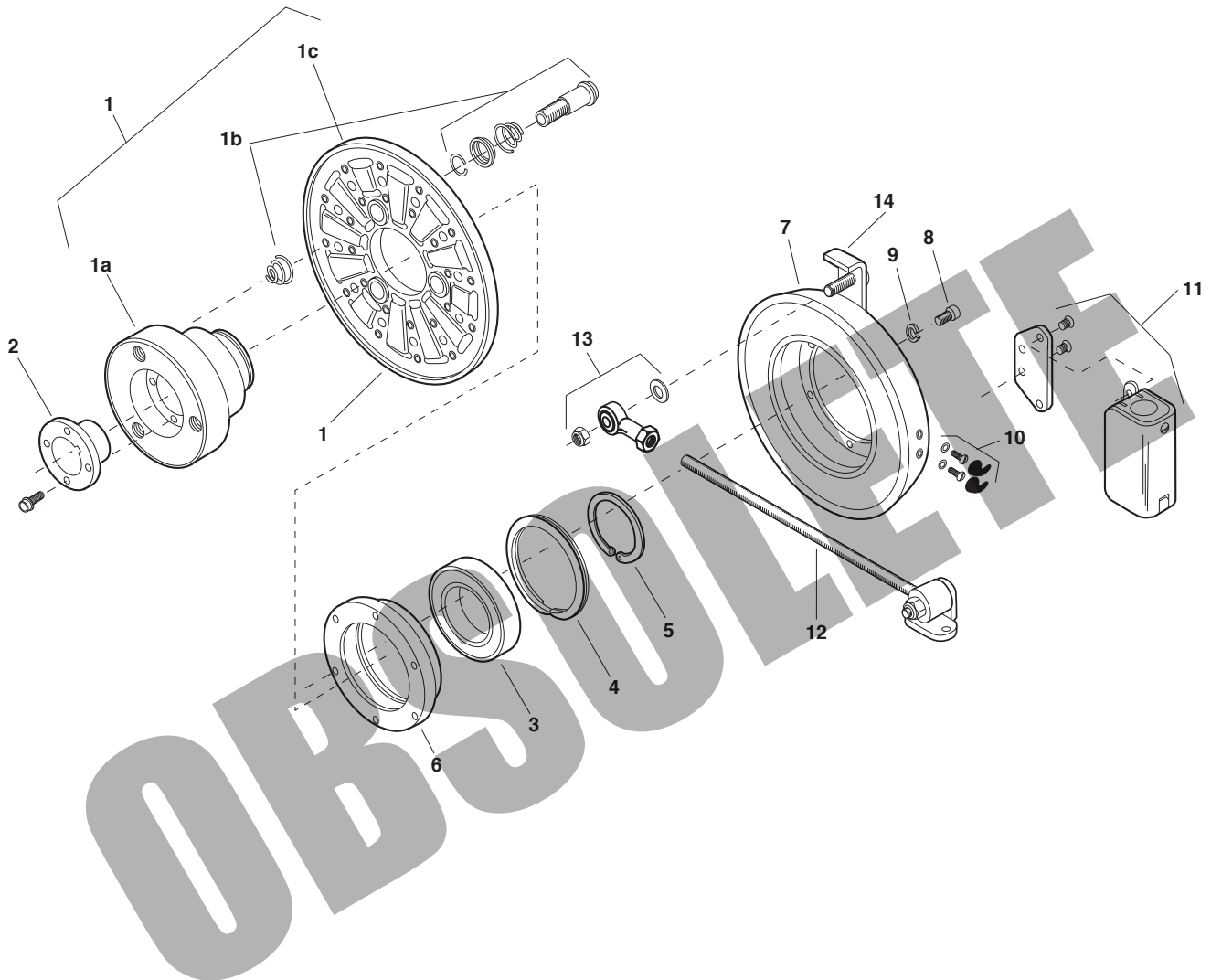

Service Parts

Component Parts

EB-825			
Item	Description	Part No.	Qty.
1	Armature Assembly	5383-111-001	1
	1a Hub	540-1299	1
	1b Autogap Assembly	5201-101-008	3
	1c Armature	5282-111-001	1
2	*Bushing	180-0002 to 180-0018 1/2" to 1-1/2" Bore	1
3	Ball Bearing	166-0168	1
4	Retainer Ring	748-0120	1
5	Retainer Ring	748-0584	1
6	Adapter Ring	748-0631	1

*See page 198 for specific part numbers.
Refer to Service Manual P-211.

These units when used with the correct Warner Electric conduit box, meets the standards of UL508 and are listed under guide care #NMTR, file #59164.



EB-825			
Item	Description	Part No.	Qty.
7	Magnet Assembly		1
	6 volt	5383-631-006	
	24 volt	5383-631-007	
	90 volt	5383-631-008	
8	Cap screw	797-0079	6
9	Lockwasher	950-0372	6
10	Terminal Accessory	5311-101-001	1
11	Conduit Box	5200-101-011	1
12	Torque Arm Rod Assembly	5382-112-001	1
13	Rod End Assembly	5382-101-007	1
14	Torque Arm Kit (bolt-on)	5383-101-001	1

OBSOLETE

EB Series Electro Brake

EB-1000, EB-1225

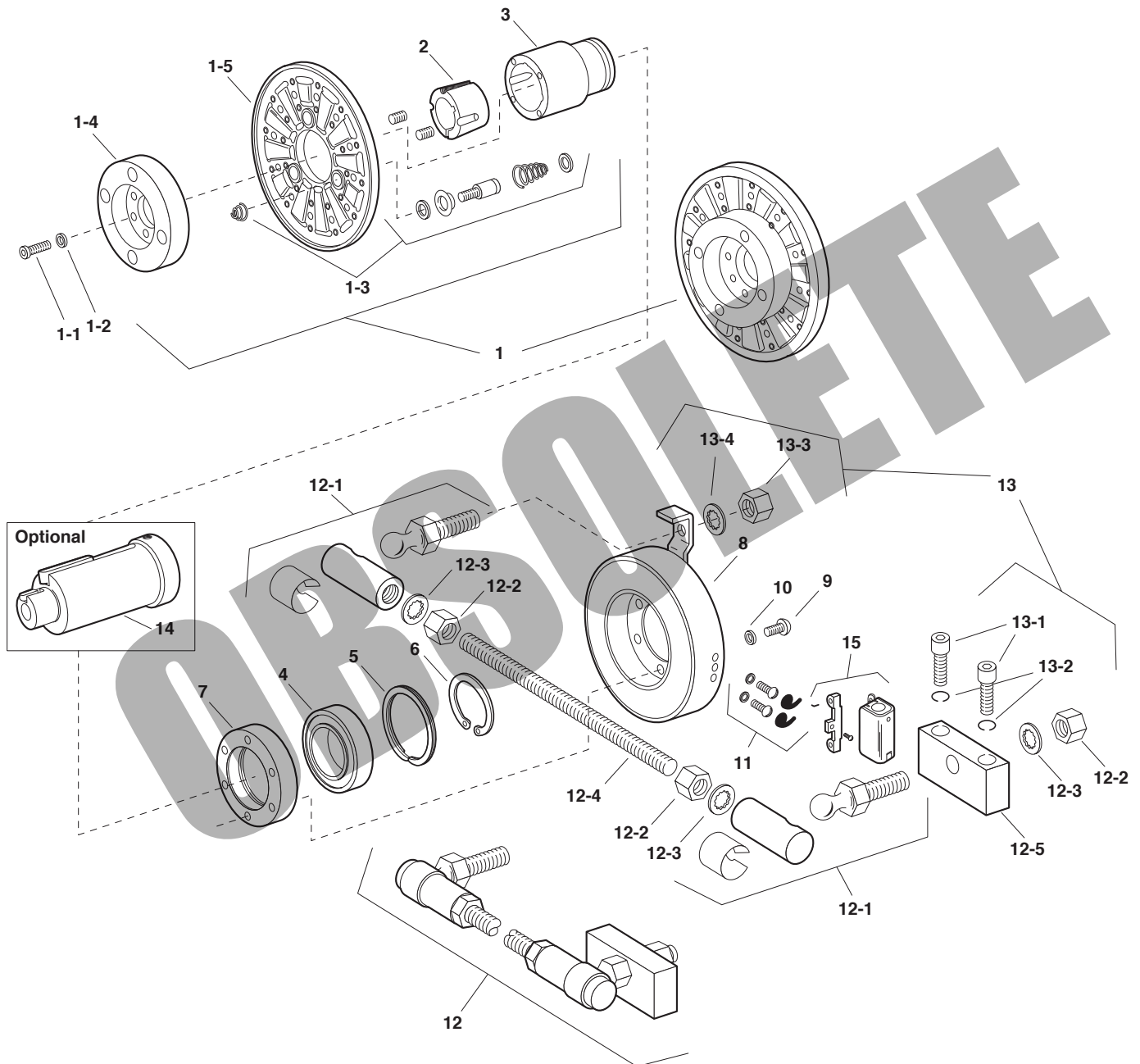

Service Parts

Component Parts

Item	Description	EB-1000		EB-1225	
		Part No.	Qty.	Part No.	Qty.
1	Armature & Carrier Assembly	5384-111-003	1	5385-111-004	1
	1-1 Capscrew	797-1163	6	797-1163	8
	1-2 Lockwasher	950-0111	6	950-0111	8
	1-3 Autogap Accessory	5201-101-008	3	5201-101-008	4
	1-4 Hub	540-1339	1	540-1341	1
	1-5 Armature	5302-111-013	1	5385-111-003	1
2	*Bushing	180-0131-180-0149 1/2" to 1-5/8" bore	1	180-0185-180-0217 1/2" to 2-1/2" bore	1
3	Hub	540-0579	1	540-0578	1
4	Ball Bearing	166-0164	1	166-0163	1
5	Retainer Ring	748-0116	1	748-0114	1
6	Retainer Ring	748-0501	1	748-0074	1
7	Adapter Ring	748-0467	1	748-0465	1
8	Magnet Assembly		1		1
	6 volt	5384-631-010		5385-631-010	
	24 volt	5384-631-011		5385-631-011	
	90 volt	5384-631-012		5385-631-012	
9	Capscrew	797-0416	6	797-0416	6
10	Lockwasher	950-0106	6	950-0106	6
11	Terminal Accessory	5311-101-001	1	5311-101-001	1
12	Torque Arm Rod Assembly	5385-757-001	1	5385-757-001	1
	12-1 Ball Joint	585-0001	2	585-0001	2
	12-2 Jam Nut	661-0012	3	661-0012	3
	12-3 Lockwasher	950-0114	3	950-0114	3
	12-4 Threaded Rod	756-0030	1	756-0030	1
	12-5 Bracket	174-0073	1	174-0073	1
13	Torque Arm Mounting Accessory	5385-101-001	1	5385-101-001	1
	13-1 Capscrew	797-0293	2	797-0293	2
	13-2 Lockwasher	950-0354	2	950-0354	2
	13-3 Jam Nut	661-0012	1	661-0012	1
	13-4 Lockwasher	950-0114	1	950-0114	1
14	Adapter (optional)		1		1
	1-5/8" Motor Shaft	5384-101-008			
	1-7/8" Motor Shaft	5384-101-007			
	2-1/8" Motor Shaft	5384-101-010		5385-101-008	
	2-3/8" Motor Shaft			5385-101-007	
15	Conduit Box	5200-101-011	1	5200-101-011	1

*See page 198 for specific part numbers.
Refer to Service Manual P-211.

These units when used with the correct Warner Electric conduit box, meets the standards of UL508 and are listed under guide care #NMTR, file #59164.



ATC Series AT Clutch

ATC-25, ATC-55, ATC-115

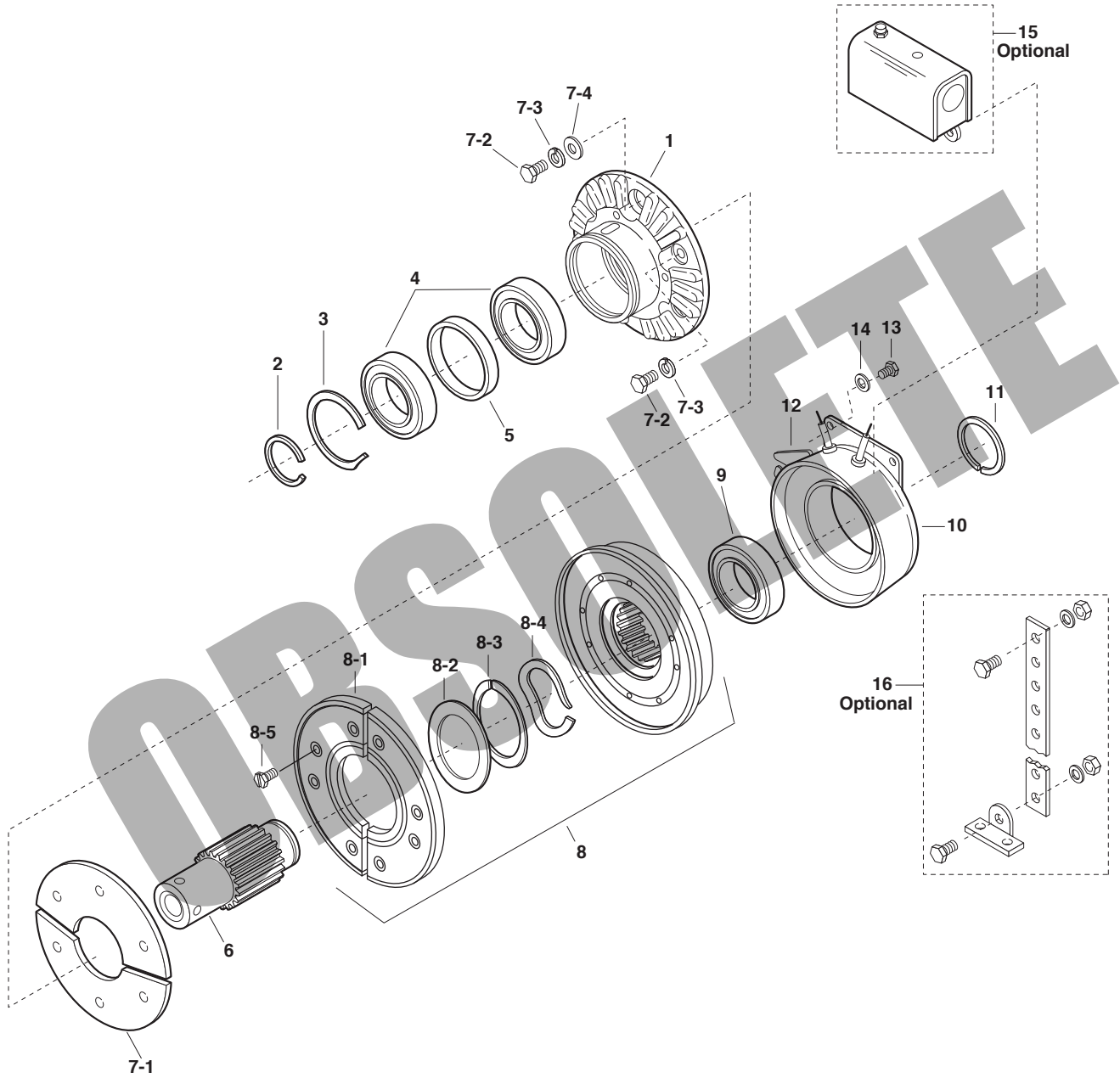

Service Parts

ATC Series AT Clutch

ATC-25, ATC-55, ATC-115

Component Parts

Item	Description	ATC-25		ATC-55		ATC-115	
		Part No.	Qty.	Part No.	Qty.	Part No.	Qty.
1	Armature Hub	540-0907	1	540-0852	1	540-0863	1
2	Retaining Ring	748-0732	1	748-0726	1	748-0737	1
3	Retaining Ring	748-0731	1	748-0728	1	748-0736	1
4	Bearing	166-0278	2	166-0277	2	166-0279	2
5	Spacer	807-0119	1	807-1061	1	807-1063	1
6	Splined Hub		1		1		1
	1/2" Bore	540-0910					
	5/8" Bore	540-0911					
	3/4" Bore	540-0912		540-1501			
	7/8" Bore	540-0913		540-1502			
	1" Bore			540-1503			
	1-1/8" Bore			540-1504		540-0857	
	1-1/4" Bore					540-0858	
1-3/8" Bore					540-0859		
1-1/2" Bore					540-0860		
*7-1	Armature	110-0220	1	110-0218	1	110-0223	1
*7-2	Screw	797-1519	4	797-1462	6	797-1463	6
*7-3	Lockwasher	950-0436	4	950-0355	6	950-0355	6
*7-4	Flatwasher			950-0023	2	950-0023	2
*8	Rotor	5161-751-001	1	5162-751-001	1	5163-751-001	1
8-1	Facing Assembly	5161-445-003	1	5162-445-003	1	5163-445-003	1
8-2	Retainer Plate					686-0108	1
8-3	Detent Ring	748-2031	1	748-2038	1	748-2020	1
8-4	Wave Spring	808-0404	1	808-0401	1	808-0384	2
8-5	Machine Screw	797-1389	8	797-1389	8	797-1389	8
*9	Bearing	166-0283	1	166-0284	1	166-0279	1
10	Field Assembly		1		1		1
	6 volts DC	5161-451-002		5162-451-002		5163-451-002	
	90 volts DC	5161-451-003		5162-451-003		5163-451-003	
	24 volts DC	5161-451-004		5162-451-004		5163-451-004	
*11	Retainer Ring	748-0018	1	748-0727	1	748-0737	1
12	Adapter					104-0300	2
13	Screw					797-1396	4
14	Lockwasher					950-0102	4
Optional Accessory Items							
15	Conduit box 100-1	5162-101-002	1	5162-101-002	1	5162-101-002	1
16	Restraining Arm Assembly	5162-101-004	1	5162-101-004	1	5163-101-004	1
Kit Items							
	* Clutch Rebuild Kit	5161-101-011	1	5162-101-011	1	5163-101-011	1
(includes items 7-1, 7-2, 7-3, 7-4, 8, 9, 11)							
Note: In some versions of this product, item 8 consists of a one (1) piece rotor.							
	Friction Face Replacement Kit	5161-101-007		5162-101-007		5163-101-007	
For Clutches with Replaceable Friction Face Only							
Mounting Accessory Kits (not shown)							
1	1/2" Bore - 3/4" Bore	5161-101-001					
1-1	Ring Retainer Ext.	748-0734	1				
1-2	Wire Retainer	742-0027	1				
1-3	Key	590-0104	1				
1-4	Setscrew	797-1393	2				
1	7/8" Bore	5161-101-002					
1-1	Ring Retainer Ext.	748-0734	1				
1-2	Wire Retainer	742-0027	1				
1-3	Key	590-0104	1				
1-4	Collar and Setscrew	266-0031	1				
1	3/4" Bore - 1" Bore			5162-101-001			
1-1	Ring Retainer Ext.			748-0725	1		
1-2	Wire Retainer			742-0026	1		
1-3	Key			590-0103	1		
1-4	Setscrew			797-1386	2		
1	1-1/8" Bore			5162-101-010			
1-1	Ring Retainer Ext.			748-0725	1		
1-2	Wire Retainer			742-0026	1		
1-3	Key			590-0103	1		
1-4	Setscrew			797-1077	2		
1-5	Collar			266-0032	1		
1	All bore sizes					5163-101-001	
1-1	Ring Retainer Ext.					748-0738	1
1-2	Wire Retainer					742-0026	1
1-3	Key					590-0105	1
1-4	Setscrew					797-1395	2

ATB Series AT Brake

ATB-25, ATB-55, ATB-115

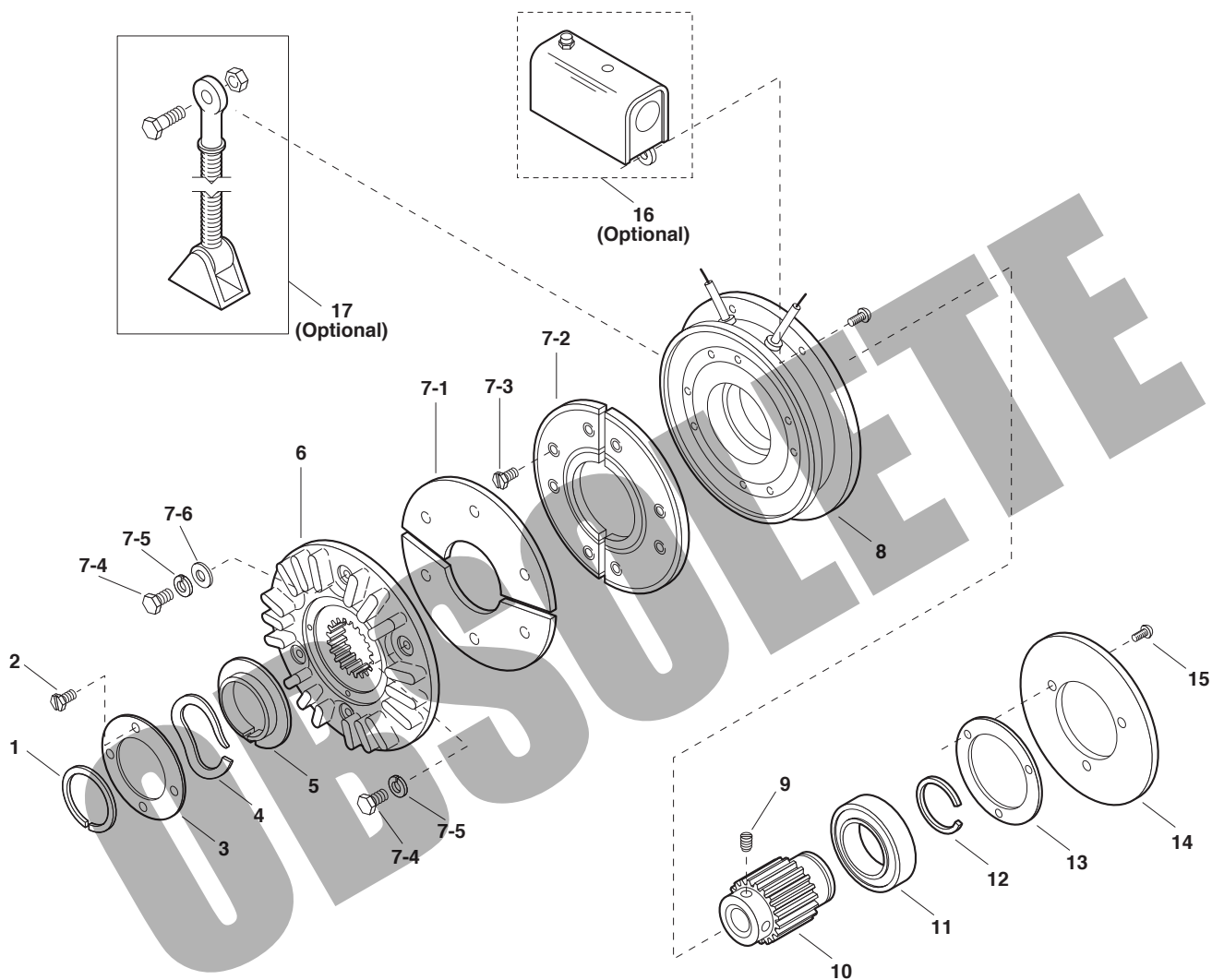

Electrical and Mechanical Data

Model Size	Voltage DC	Unit	Resistance (Ohms)	Current (Amps)	Watts	Coil Build Up (MMS)	Coil Decay (MMS)	Inertia*—WR ² (lb.ft. ²)	Max. RPM	Weight lbs.
25	6	Brake	1.37	4.38	26.3	145	9	.048	3600	8
	24		20.2	1.19	28.6	145	9	.048	3600	8
	90		290	.31	27.9	145	9	.048	3600	8
55	6	Brake	1.21	4.96	29.8	210	35	.173	3600	18
	24		19.6	1.22	29.3	210	35	.173	3600	18
	90		230	.39	35.2	210	35	.173	3600	18
115	6	Brake	1.02	5.91	35.4	150	45	.483	3600	28
	24		16.5	1.46	35	150	45	.483	3600	28
	90		182	.50	44.6	150	45	.483	3600	28

Service Parts

ATB Series AT Brake

ATB-25, ATB-55, ATB-115

Component Parts

Item	Description	ATB-25		ATB-55		ATB-115	
		Part No.	Qty.	Part No.	Qty.	Part No.	Qty.
†1	Retainer	748-0018	1	748-0727	1	748-0737	1
†2	Screw	797-0321	3	797-0321	4	797-0321	4
3	Plate	686-0166	1	686-0162	1	686-0171	1
†4	Wave Spring	808-0404	1	808-0401	1	808-0384	2
†5	Detent Ring	748-2031	1	748-2038	1	748-2020	1
6	Armature Hub	540-0908	1	540-0851	1	540-0864	1
*†7-1	Armature	110-0220	1	110-0218	1	110-0223	1
*†7-2	Facing Assembly	5161-445-003	1	5162-445-003	1	5163-445-003	1
*†7-3	Screw	797-1389	6	797-1389	8	797-1389	8
*†7-4	Screw	797-1519	4	797-1462	6	797-1463	6
*†7-5	Lockwasher	950-0436	4	950-0355	4	950-0355	6
*†7-6	Flatwasher			950-0023	2	950-0023	2
8	Magnet Assembly		1		1		1
	6 volts DC	5191-631-002		5192-631-002		5193-631-002	
	24 volts DC	5191-631-004		5192-631-004		5193-631-004	
	90 volts DC	5191-631-003		5192-631-003		5193-631-003	
†9	Setscrew	797-1393	2	797-1386	2	797-1395	2
10	Splined Hub		1		1		1
	1/2" Bore	540-0901					
	5/8" Bore	540-0902					
	3/4" Bore	540-0903		540-1512			
	7/8" Bore	540-0904		540-1513			
	1" Bore			540-1514			
	1-1/8" Bore			540-1515		540-0866	
1-1/4" Bore					540-0867		
1-3/8" Bore					540-0868		
1-1/2" Bore					540-0869		
†11	Ball Bearing	166-0283	1	166-0277	1	166-0279	1
†12	Retainer Ring	748-0018	1	748-0726	1	748-0737	1
13	Shim	801-1035	1	801-1034	1	801-1036	1
14	Backplate	686-0167	1	686-0163	1	686-0172	1
†15	Screw	797-1392	4	797-0437	3	797-0447	3
Optional Accessory Items							
16	Conduit box	5162-101-002	1	5162-101-002	1	5162-101-002	1
17	Torque Arm	5191-101-001	1	5192-101-001	1	5193-101-001	1
Kit Items							
*†18	Friction Face Replacement Kit (includes items 7-1, 7-2, 7-3, 7-4, 7-5, 7-6)	5161-101-007	1	5162-101-007	1	5163-101-007	1
†19	Brake Rebuild Kit (includes items, 1, 2, 4, 5, 7-1, 7-2, 7-3, 7-4, 7-5, 7-6, 9, 11, 12, 15)	5191-101-006	1	5192-101-006	1	5193-101-006	1

Refer to Service Manual P-218.

Service Parts

EP Series Electro Pack

EP-170, EP-250, EP-400

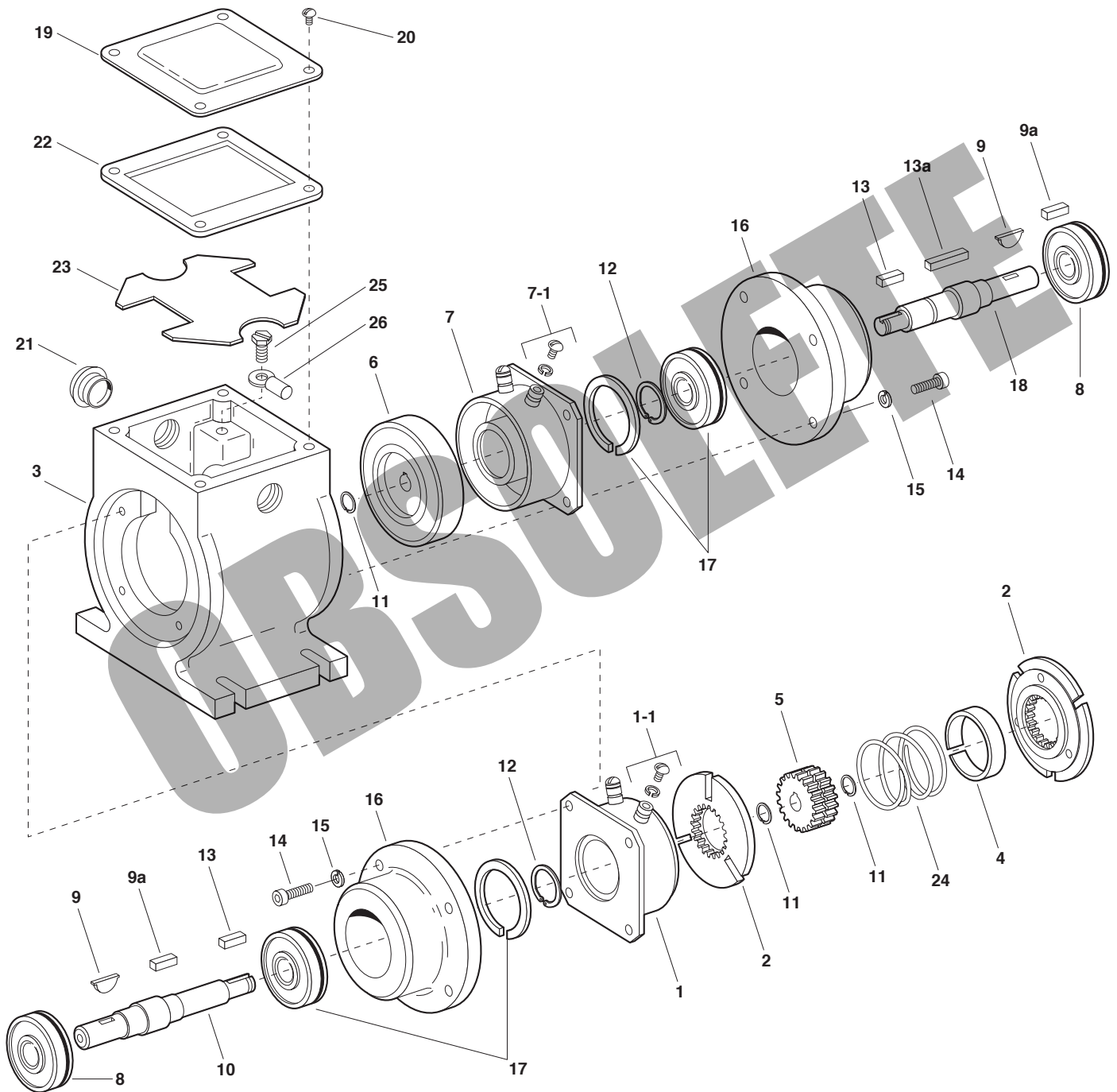

Service Parts

Component Parts

Item	Description	EP-170		EP-250		EP-400	
		Part No.	Qty.	Part No.	Qty.	Part No.	Qty.
1	Magnet Assembly		1		1		1
	6 volt	5375-631-003		5319-631-002		5115-631-002	
	24 volt	5375-631-005		5319-631-003		5115-631-003	
	90 volt	5375-631-007		5319-631-005		5115-631-004	
1-1	Terminal Accessory	†		5103-101-002	1	5103-101-002	1
2	Armature Assembly with Autogap	110-0111	2	5130-111-008	2	5131-111-001	2
3	Housing	535-0079	1	535-0082	1	535-0083	1
4	Armature Spacer	807-1021	1				
5	Splined Armature Hub	540-1250	1	540-1635	1	540-2034	1
6	Rotor Assembly	5603-751-029	1	5103-751-010	1	5104-751-034	1
7	Field Assembly		1		1		1
	6 volt	5603-451-047		5103-451-002		5104-451-032	
	24 volt	5603-451-049		5103-451-004		5104-451-033	
	90 volt	5603-451-051		5103-451-007		5104-451-034	
7-1	Terminal Accessory	†		5103-101-002	1	5103-101-002	1
8	Ball Bearing	166-0112	2	166-0114	2	166-0116	2
9	Key	590-0095	2	590-0014	2		
9a	Key					590-0016	2
10	Shaft, Brake	798-0136	1	798-0133	1	798-0131	1
11	Retainer Ring	748-0346	2	748-0347	2	748-0348	2
12	Retainer Ring	748-0042	2	748-0024	2	748-0022	2
13	Key	590-0089	2	590-0088	2	590-0087	1
13a	Key					590-0106	1
14	Capscrew	797-1219	8	797-1219	8	797-1220	8
15	Lockwasher	950-0351	8	950-0351	8	950-0355	8
16	Bearing Housing	535-0080	2	535-0081	2	535-0084	2
17	Ball Bearing, with Retainer	166-0111	2	166-0113	2	166-0115	2
18	Shaft, Clutch	798-0135	1	798-0134	1	798-0132	1
19	Cover Plate	686-1017	1	686-1018	1	686-1019	1
20	Screw	797-0015	4	797-0015	4	797-0015	4
21	Dust Plug	680-0037	2	680-0037	2	680-0037	2
22	Gasket	495-0003	1	495-0004	1	495-0005	1
23	Insulator	572-0573	1	572-0572	1	572-0574	1
24	Vertical Mfg. Spring Kit Optional	5603-101-001	1	5103-101-006	1	5104-101-005	1
25	Ground Screw		1	797-1245	1	797-1245	1
26	Terminal		1	900-0116	1	900-0016	1

†Lead wires used on EP-170.

These units meet the standards of UL508 and are listed under guide card #NMTR, file #59164.



Service Parts

EP Series Electro Pack

EP-500

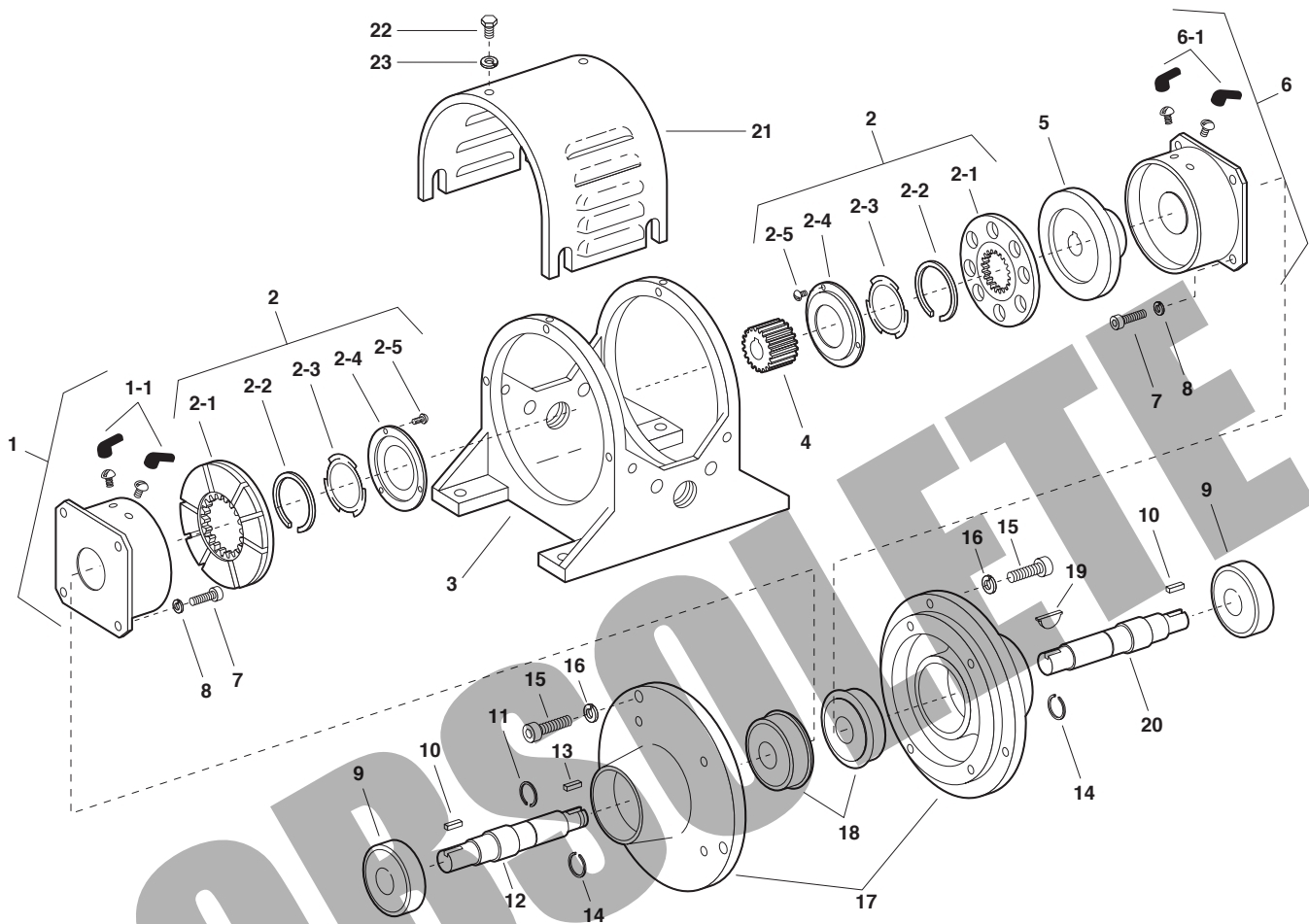

Component Parts

Item	Description	Part No.	Qty.
1	Magnet Assembly		1
	6 volt	5300-631-009	
	24 volt	5300-631-010	
	90 volt	5300-631-011	
1-1	Terminal Accessory	5311-101-001	1
2	Armature Assembly	5230-111-002	2
2-1	Armature	5230-111-001	2
2-2	Retainer Ring	748-0355	2
2-3	Spring	808-0412	2
2-4	Retainer Plate	748-0364	2
2-5	Screw	797-0028	12
3	Mounting Frame	174-0028	1
4	Splined Hub	540-2035	1
5	Rotor	5230-751-001	1
6	Field		1
	6 volt	5230-451-003	
	24 volt 90 volt	5230-451-005 5230-451-002	

Refer to Service Manual P-212.
These units meet the standards of UL508 and are listed under guide card #NMTR, file #59164.



Item	Description	Part No.	Qty.
6-1	Terminal Accessory	5311-101-001	1
7	Capscrew	797-0416	8
8	Lockwasher	950-0107	8
9	Ball Bearing	166-0125	2
10	Key	590-0020	2
11	Retainer Ring	748-0361	1
12	Shaft, Brake	798-0022	1
13	Key	590-0022	1
14	Retainer Ring	748-0335	2
15	Capscrew	797-0418	8
16	Lockwasher	950-0107	8
17	Endbell Housing	535-0010	2
18	Ball Bearing	166-0127	2
19	Key	590-0021	1
20	Shaft, Clutch	798-0023	1
21	Cover Drip Proof	287-0068	1
22	Capscrew	797-1214	6
23	Lockwasher	950-0102	6

Service Parts

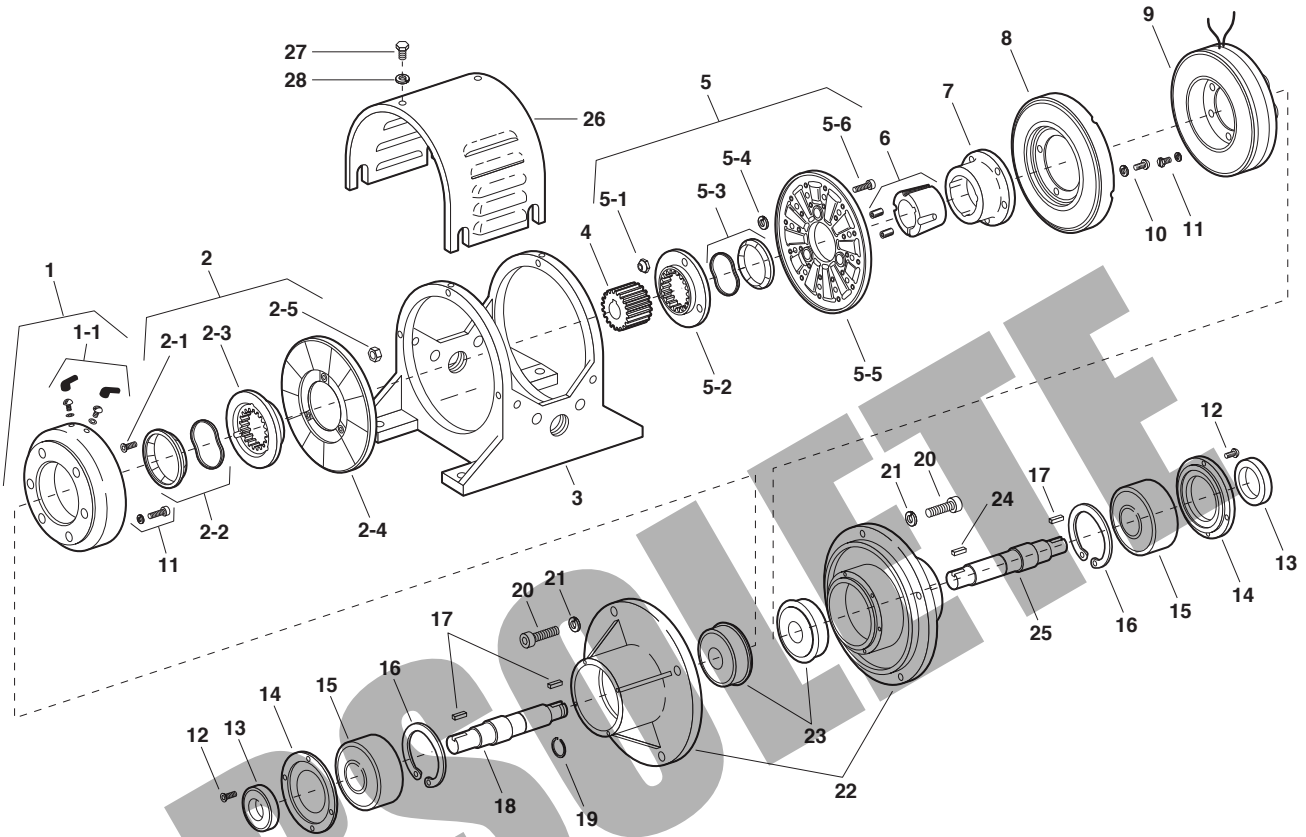

Component Parts

Item	Description	Part No.	Qty.
1	Magnet Assembly		1
	6 volt	5311-631-002	
	24 volt	5311-631-003	
	90 volt	5311-631-004	
1-1	Terminal Accessory	5311-101-001	1
2	Armature Assembly & Splined Adapter	5321-111-001	1
2-1	Screw	797-0272	3
2-2	Autogap Accessory	5321-101-006	1
2-3	Splined Adapter	104-0008	1
2-4	Armature	5321-111-022	1
2-5	Locknut	661-0004	3
3	Frame	174-0019	1
4	Splined Hub	540-0320	1
5	Armature & Splined Adapter	5201-111-001	1
5-1	Locknut	661-0004	3
5-2	Splined Adapter	104-0008	1
5-3	Autogap Accessory	5321-101-006	1
5-4	Spacer	748-0333	3
5-5	Armature	5321-111-022	1
5-6	Screw	797-0341	3
6	Bushing, 1-1/4" Bore	180-0113	1
7	Rotor Hub	540-0013	1
8	Rotor	5201-751-003	1
9	Field		1
	6 volt	5201-451-006	
	24 volt	5201-451-008	
	90 volt	5201-451-010	

Item	Description	Part No.	Qty.
10	Mounting Accessory	5201-101-007	1
11	Mounting Accessory	5321-101-001	2
12	Screw	797-1008	8
13	Oil Seal	795-0023	2
14	Retainer Plate	686-0031	2
15	Ball Bearing	166-0126	2
16	Retainer Ring	748-0336	2
17	Key	590-0019	3
18	Shaft, Brake	798-0019	1
19	Retainer Ring	748-0335	1
20	Capscrew	797-0351	8
21	Lockwasher	950-0354	8
22	Endbell Housing	535-0005	2
23	Ball Bearing	166-0125	2
24	Key	590-0018	1
25	Shaft, Clutch	798-0020	1
26	Cover, Drip Proof	287-0069	1
27	Capscrew	797-1214	6
28	Lockwasher	540-0102	6

Refer to Service Manual P-212.

These units meet the standards of UL508 and are listed under guide card #NMTR, file #59164.



EP Series Electro Pack

EP-1000

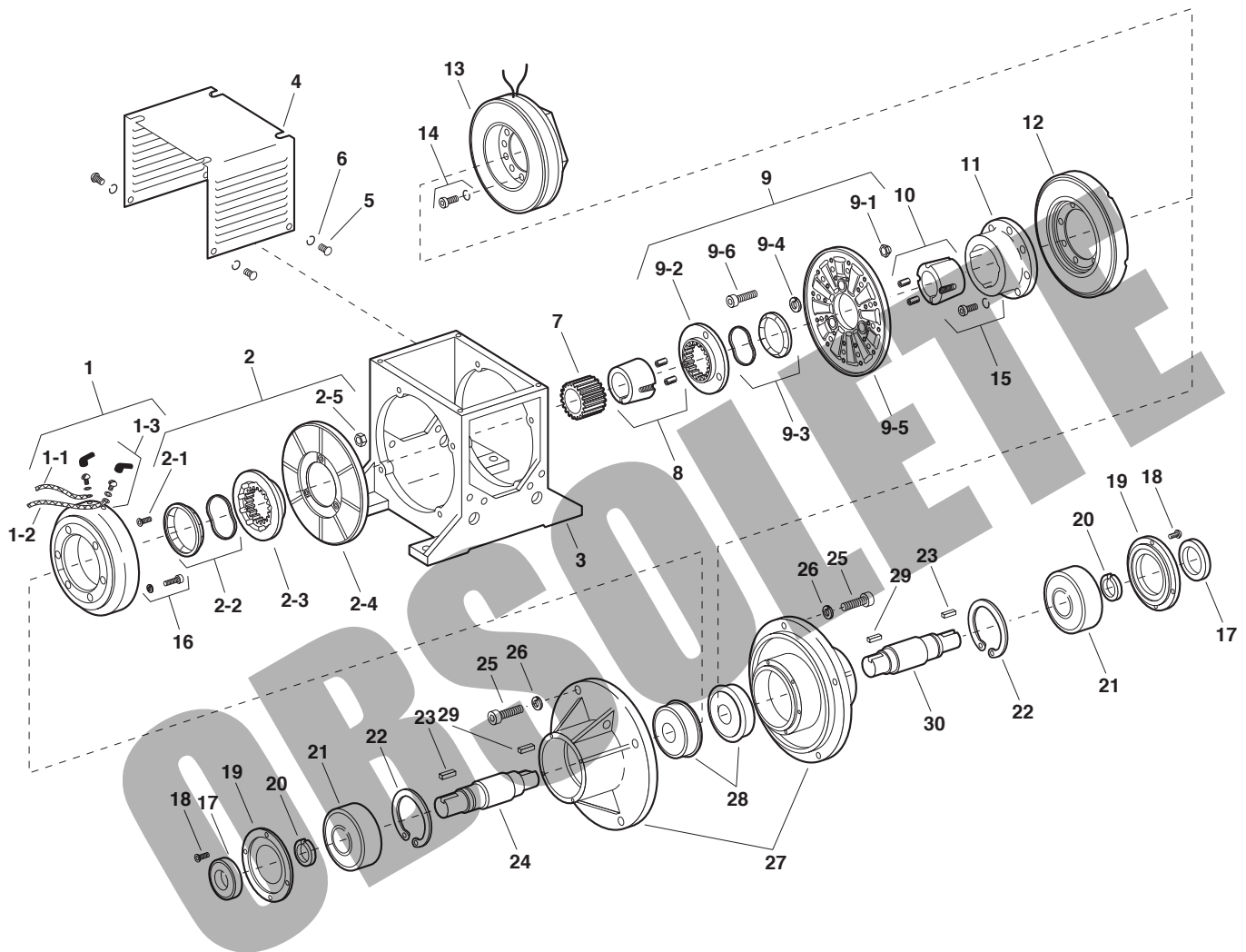

Service Parts

Component Parts

Item	Description	Part No.	Qty.
1	Magnet Assembly		1
	6 volt	5312-631-004	
	24 volt	5312-631-005	
	90 volt	5312-631-006	
1-1	Wire Assembly	5232-954-003	1
1-2	Wire Assembly	5232-954-004	1
1-3	Terminal Accessory	5311-101-001	1
2	Armature & Splined Adapter	5322-111-002	1
2-1	Button Head Screw	797-0272	1
2-2	Autocap Accessory	5322-101-004	1
2-3	Splined Arm, Adapter	104-0009	1
2-4	Armature	5322-111-036	1
2-5	Locknut	661-0004	3
3	Frame	174-0043	1
4	Dust Cover	287-0052	1
5	Button Head Screw	797-1175	8
6	Lockwasher	950-0103	8
7	Splined Armature Hub	540-0061	1
8	Bushing, 1-7/8" Bore	180-0177	1
9	Armature & Splined Adapter	5202-111-001	1
9-1	Locknut	661-0004	3
9-2	Splined Armature Adapter	104-0009	1
9-3	Autogap Accessory	5322-101-004	1
9-4	Spacer	748-0333	3
9-5	Armature	5322-111-036	1

Refer to Service Manual P-212.
These units meet the standards of UL508 and are listed under guide card #NMTR, file #59164.



Item	Description	Part No.	Qty.
9-6	Capscrew	797-0341	3
10	Bushing, 2" Bore	180-0179	1
11	Rotor Hub	540-0315	1
12	Rotor	5202-751-003	1
13	Field Assembly		1
	6 volt	5202-451-004	
	24 volt	5202-451-006	
	90 volt	5202-451-007	
14	Mounting Accessory	5321-101-001	1
15	Mounting Accessory	5201-101-007	1
16	Mounting Accessory	5321-101-001	1
17	Oil Seal	795-0024	2
18	Button Head Screw	797-1008	8
19	Retainer Plate	686-0047	2
20	Retainer Ring – External	748-0504	2
21	Ball Bearing	166-0130	2
22	Retainer Ring – Internal	748-0375	2
23	Key	590-0024	2
24	Shaft, Brake	798-0026	1
25	Capscrew	797-0361	8
26	Lockwasher	950-0362	8
27	Bearing Housing	535-0012	2
28	Ball Bearing	166-0131	2
29	Key	590-0025	2
30	Shaft, Clutch	798-0025	1

Service Parts

EP Series Electro Pack

EP-1525, EP-1525HT

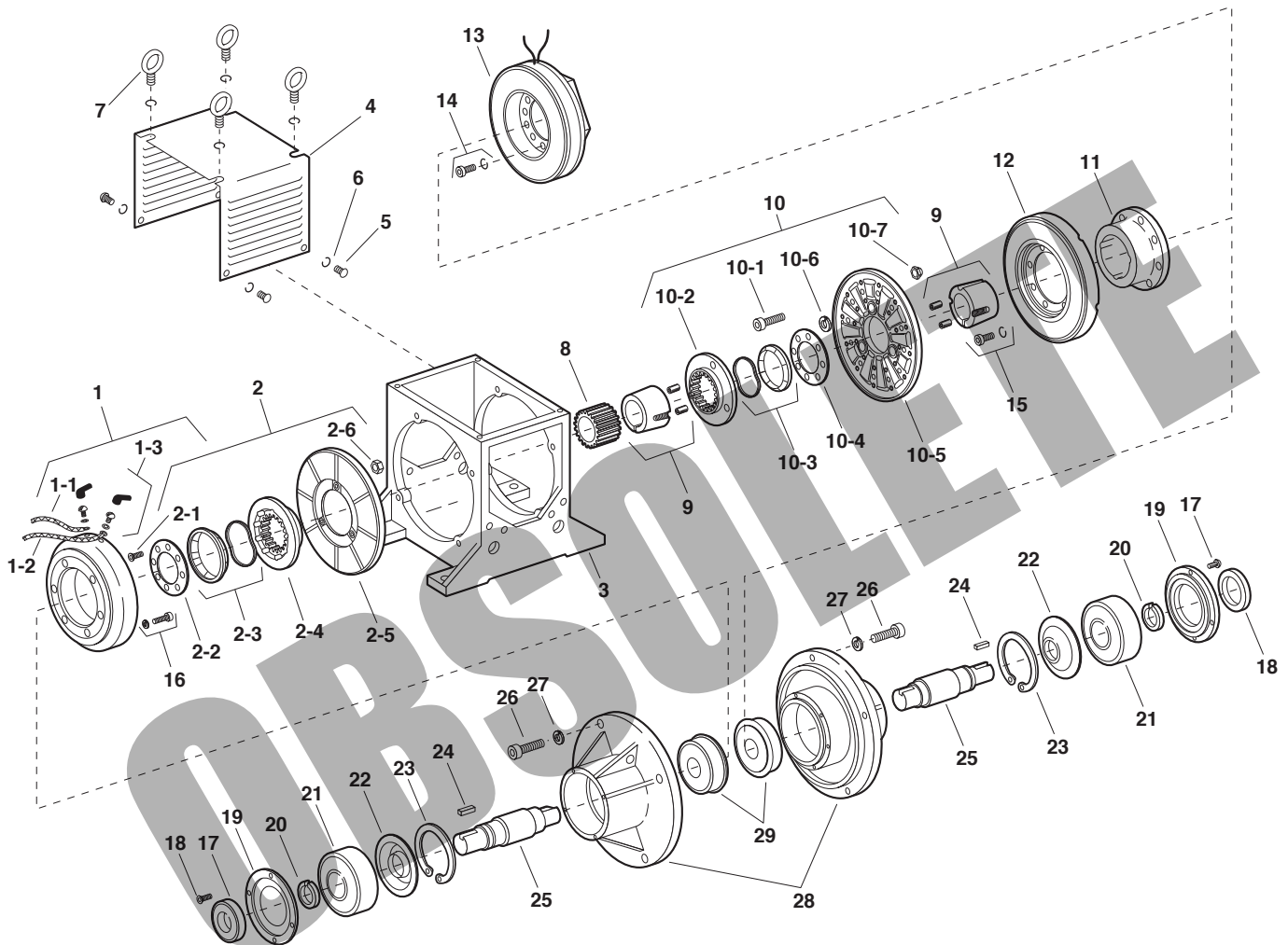

Service Parts

Component Parts

Item	Description	EP-1525		EP-1525HT	
		Part No.	Qty.	Part No.	Qty.
1	Magnet		1		1
	6 volt	5314-631-004			
	24 volt 90 volt			5314-631-006 5314-631-005	
*1-1	Wire Assembly	5232-954-003	1	5232-954-003	1
*1-2	Wire Assembly	5232-954-004	1	5232-954-004	1
*1-3	Terminal Accessory	5311-101-001	1	5311-101-001	1
2	Armature & Splined Adapter	5324-111-001	1	5324-111-001	1
*2-1	Button Head Screw	797-0272	8	797-0272	8
*2-2	Armature Plate	686-0003	1	686-0003	1
*2-3	Autogap Accessory	5323-101-002	1	5323-101-002	1
*2-4	Splined Armature Adapter	104-0011	1	104-0011	1
*2-5	Armature	5324-111-034	1	5324-111-034	1
*2-6	Locknut	661-0004	8	661-0004	8
3	Frame	174-0044	1	174-0044	1
4	Dust Cover	287-0040	1	287-1002	1
5	Button Head Screw	797-1175	8	797-1175	8
6	Lock Washer	950-0103	8	950-0103	8
7	Eye Bolts	171-0006	4	171-0006	4
8	Splined Armature Hub	540-0063	1	540-0063	1
9	Bushing, 2-3/8" Bore	180-0215	2	180-0215	2
10	Armature & Splined Adatper	5204-111-004	1	5204-111-004	1
*10-1	Capscrew	797-0342	8	797-0342	8
*10-2	Splined Armature Adapter	104-0011	1	104-0011	1
*10-3	Autogap Accessory	5323-101-002	1	5323-101-002	1
*10-4	Retainer Plate	686-0003	1	686-0003	1
*10-5	Armature	5324-111-034	1	5324-111-034	1
*10-6	Spacer	748-0333	8	748-0333	8
*10-7	Locknut	661-0004	8	661-0004	8
11	Rotor Hub	5234-541-001	1	5234-541-001	1
12	Rotor	5204-751-002	1	5204-751-001	1
13	Field Assembly		1		1
	6 volt	5204-451-013			
	24 volt 90 volt			5204-451-066 5204-451-006	
14	Mounting Accessory	5321-101-002	2	5321-101-002	2
15	Mounting Accessory	5321-101-001	2	5321-101-001	2
16	Mounting Accessory	5321-101-001	2	5321-101-001	2
17	Screw	797-0294	8	797-0294	8
18	Oil Seal	795-0025	2	795-0025	2
19	Retainer Plate	686-0048	2	686-0048	2
20	Retaining Ring – External	748-0503	2	748-0503	2
21	Ball Bearing	166-0132	2	166-0132	2
22	Bearing Seal	795-0036	2	795-0036	2
23	Retainer Ring – Internal	748-0552	2	748-0052	2
24	Key	590-0028	2	590-0028	2
25	Shaft	798-0027	2	798-0027	2
26	Capscrew	797-0362	12	797-0362	12
27	Lock Washer	950-0362	12	950-0362	12
28	Bearing Housing	535-0013	2	535-0013	2
29	Ball Bearing	166-0133	2	166-0133	2

*Shipped Assembled
Refer to Service Manual P-212.
These units meet the standards of UL508 and are listed under guide card #NMTR, file #59164.



Service Parts

Permanent Magnet Electrically Released Brakes

FB-375, FB-475, FB-650

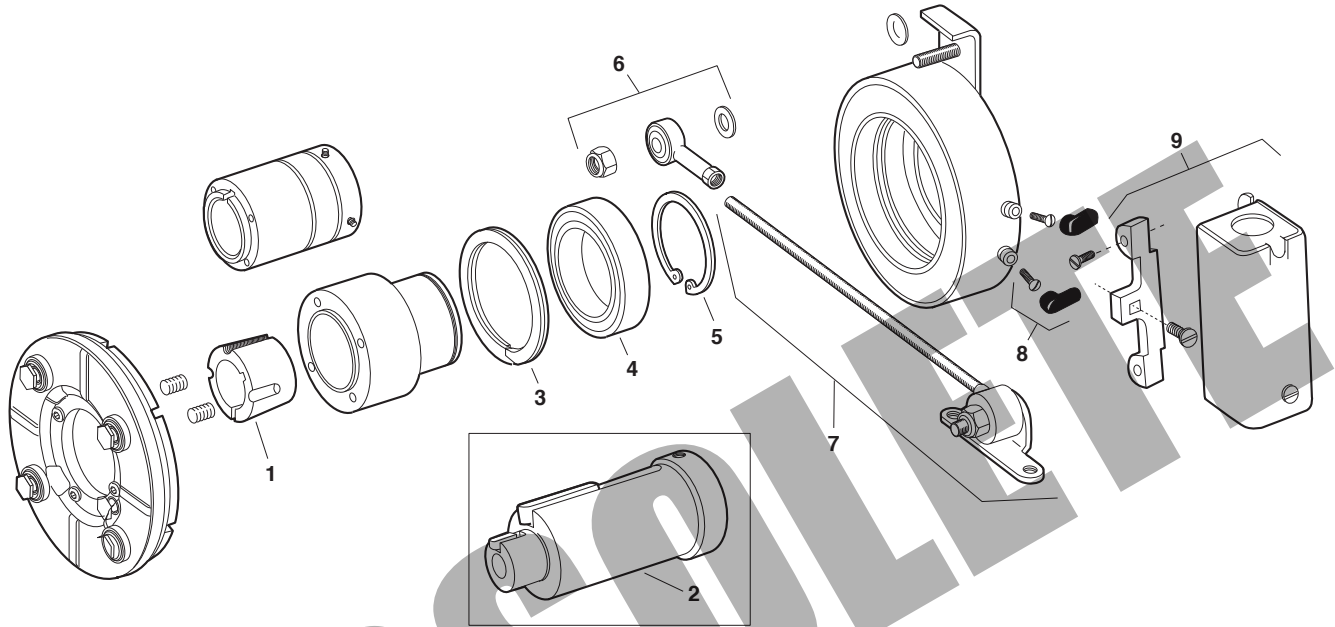

Service Parts

FB Series Electrically Released Brakes

FB-375, FB-475, FB-650

Component Parts

Item	Description	FB-375		FB-475		FB-650	
		Part Number	Qty	Part Number	Qty	Part Number	Qty
Optional Parts							
1	*Bushing	N/A		180-0410 1/2" bore to 180-0418 1" bore	1	180-0421 1/2" bore to 180-0435 1-3/8" bore	1
	Adapter (optional)		1		1		1
	5/8" motor shaft	5380-101-005					
	7/8" motor shaft	5380-101-004					
2	1-1/8" motor shaft			5381-101-003		5382-101-003	
	1-3/8" motor shaft					5382-101-002	
	1-5/8" motor shaft						
Service Parts							
3	Retainer ring	748-0101	1	748-0102	1	748-0104	1
4	Ball bearing	166-0150	1	166-0110	1	166-0104	1
5	Retainer ring	748-0018	1	748-0002	1	748-0004	1
6	Torque arm mount assembly	5380-101-007	1	5381-101-006	1	5382-101-007	1
7	Torque arm rod assembly	5380-112-001	1	5381-112-001	1	5382-112-001	1
8	Terminal accessory	5311-101-001	1	5311-101-001	1	5311-101-001	1
9	Conduit Box	5200-101-010	1	5200-101-010	1	5200-101-010	1

*See page 198 for specific part numbers.

These units, when used with the correct Warner Electric conduit box, meet the standards of UL508 and are listed under guide card #NMTR2, file #59164. Magnet and armature are not field replaceable.



OBSOLETE

Service Parts

ER Series Electrically Released Brakes

ER-375, ER-475, ER-650

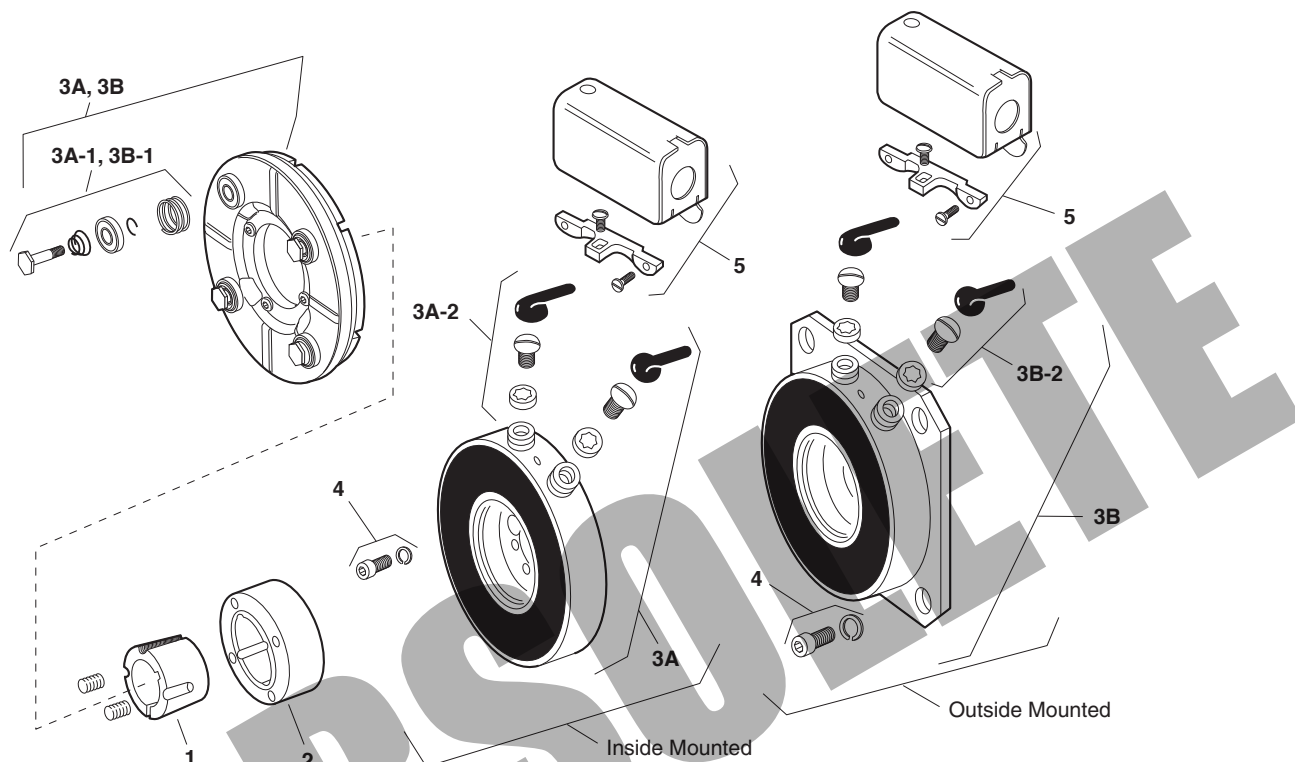

Component Parts

Item	Description	ER-375		ER-475		ER-650	
		Part Number	Qty	Part Number	Qty	Part Number	Qty
1	†Bushing			180-0410-0418 (1/2" to 1" Bore)	1	180-0421-0435 (1/2" to 1-3/8" Bore)	1
2	Hub			540-0849	1	540-0848	1
	1/2" Bore	540-0846	1				
	5/8" Bore	540-0847	1				
3A	Magnet and Armature (Inside Mounted, 90 Volt) Sold only in matched pairs*			5255-5	1	5256-6	1
3A-1	Autogap Accessory			5391-101-003	4	5392-101-003	4
3A-2	Terminal Accessory			5103-101-002	1	5103-101-002	1
3B	Magnet and Armature (Outside Mounted, 90 Volt) Sold only in matched pairs*	5254-1	1	5255-6	1	5256-7	1
3B-1	Autogap Accessory	5390-101-002	3	5391-101-003	4	5392-101-003	1
3B-2	Terminal Accessory	5103-101-002	1	5103-101-002	1	5103-101-002	1
4	Mounting Accessory						
	Inside Mount			5255-101-001	1	5256-101-003	1
	Outside Mount	5254-101-002	1	5255-101-002	1	5256-101-003	1
5	Conduit Box	5200-101-010	1	5200-101-010	1	5200-101-010	1

† See page 198 for specific part numbers.

* Magnets and armatures sold only in pre-burnished sets to assure rated torque available upon installation.

These units, when used with the correct Warner Electric conduit box, meet the standards of UL508 and are listed under guide card #NMTR2, file #59164.



Service Parts

ER Series Electrically Released Brakes

ER-825, ER-1225

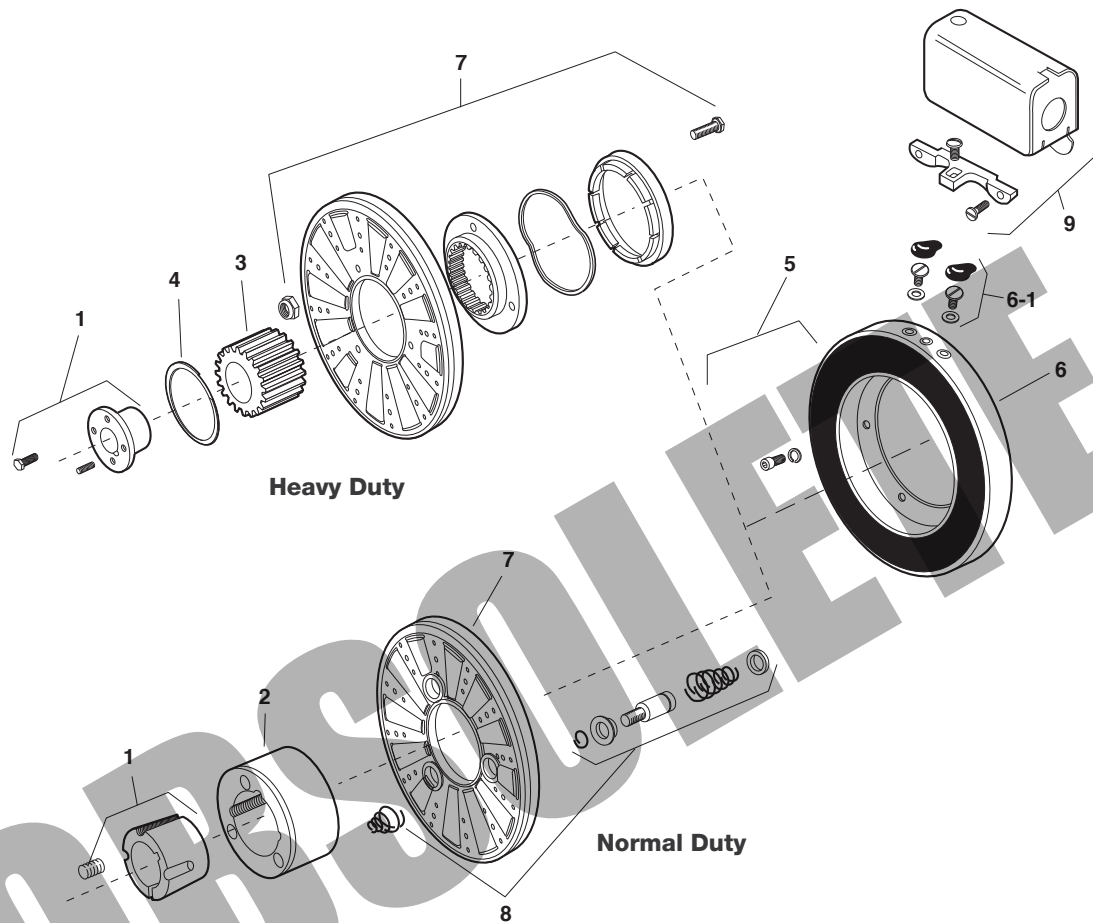

Component Parts

Item	Description	ER-825 Normal Duty		ER-825 Heavy Duty		ER-1225 Normal Duty		ER-1225 Heavy Duty	
		Part Number	Qty	Part Number	Qty	Part Number	Qty	Part Number	Qty
1	†Bushing	180-0137-180-0149 7/8" to 1-5/8" Bore	1	180-0008-180-0018 7/8" to 1-1/2" Bore	1	180-0262-180-0295 15/16" to 3" Bore	1	180-0026-180-0057 3/4" to 2-11/16" Bore	1
2	Armature Hub	540-0394	1			540-0015	1		
3	Splined Hub			540-0057	1			540-0064	1
4	Retainer Ring			748-0006	1			748-0005	1
5	Mounting Accessory, I.M.	5321-101-001	1	5321-101-001	1	5321-101-001	1	5321-101-001	1
6 & 7	Magnet (I.M., 90 volt) and Armature sold only in matched pairs*	5250-30	1	5250-25	1	5252-9	1	5252-4	1
6-1	Terminal Accessory	5311-101-001	1	5311-101-001	1	5311-101-001	1	5311-101-001	1
8	Autogap Accessory	5201-101-008	3			5201-101-008	4		
9	Conduit Box	5200-101-010	1	5200-101-010	1	5200-101-010	1	5200-101-010	1

† See page 198 for specific part numbers.

* Magnets and armatures sold only in pre-burnished sets to assure rated torque available upon installation.

These units, when used with the correct Warner Electric conduit box, meet the standards of UL508 and are listed under guide card #NMTR2, file #59164.



Service Parts

UNIBRAKES

F-Series AC Rear-Mounted Brakes

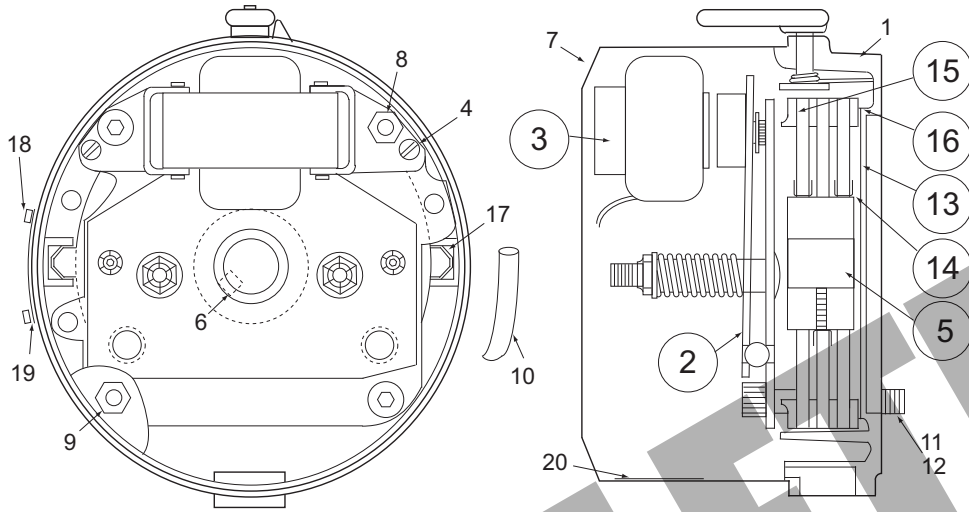

Component Parts

Item	Description	Part No.	Qty.	Item	Description			
2	Support & Armature Plate Assembly	6, 10, & 15 ft.lb.	79060-07-A	1	1	Brake Head Machined		
		3 ft.lb.	79060-07-B	1				
		275/550V 60HZ	79137-18-G	1				
		230/460V 60HZ	79137-18-J	1				
3	Coil and Pole Assembly	115/230V 60HZ	79137-18-K	1	4	10-32 X 5/16 Slotted Hex Head With Split LW		
		200/400V 60HZ	79137-18-L	1				
		208/416V 50HZ	79137-18-M	1				
		115/230V 50HZ	79137-18-N	1				
		230/460V 50HZ	79137-18-P	1				
5	Hub Assembly	5/8 Bore	58D22	1	6	3/16" SQR X 1" Key		
		3/4 Bore	58D23	1				
		7/8 Bore	58D24	1				
13	Brake Disc (Individual)	327213	1	7	Brake Cover			
13,14, 15,16	Disc Plate Kit (Includes Disc & Pressure Plates)	3 & 6 ft.lb. (1 disc)	327212-1			1	8	Stud Extension
		10 ft.lb. (2 discs)	327212-2			1		
		15 ft.lb. (3 discs)	327212-3	1				
13,14, 15,16	Disc Plate Kit (Includes Disc & Pressure Plates)	3 & 6 ft.lb. (1 disc)	327212-1	1	9	10-32 Hex Nut		
		10 ft.lb. (2 discs)	327212-2	1				
		15 ft.lb. (3 discs)	327212-3	1				
13,14, 15,16	Disc Plate Kit (Includes Disc & Pressure Plates)	3 & 6 ft.lb. (1 disc)	327212-1	1	10	Insulating Sleeve		
		10 ft.lb. (2 discs)	327212-2	1				
		15 ft.lb. (3 discs)	327212-3	1				
13,14, 15,16	Disc Plate Kit (Includes Disc & Pressure Plates)	3 & 6 ft.lb. (1 disc)	327212-1	1	11	3/8-16 X 2-1/4" Socket Cap Screw		
		10 ft.lb. (2 discs)	327212-2	1				
		15 ft.lb. (3 discs)	327212-3	1				
13,14, 15,16	Disc Plate Kit (Includes Disc & Pressure Plates)	3 & 6 ft.lb. (1 disc)	327212-1	1	12	3/8" Hi-Collar Lock Washer		
		10 ft.lb. (2 discs)	327212-2	1				
		15 ft.lb. (3 discs)	327212-3	1				
13,14, 15,16	Disc Plate Kit (Includes Disc & Pressure Plates)	3 & 6 ft.lb. (1 disc)	327212-1	1	17	Anti Rattle Spacer		
		10 ft.lb. (2 discs)	327212-2	1				
		15 ft.lb. (3 discs)	327212-3	1				
13,14, 15,16	Disc Plate Kit (Includes Disc & Pressure Plates)	3 & 6 ft.lb. (1 disc)	327212-1	1	18	6-32 X 1/4" Hex Washer Head Screw		
		10 ft.lb. (2 discs)	327212-2	1				
		15 ft.lb. (3 discs)	327212-3	1				
13,14, 15,16	Disc Plate Kit (Includes Disc & Pressure Plates)	3 & 6 ft.lb. (1 disc)	327212-1	1	19	Nameplate		
		10 ft.lb. (2 discs)	327212-2	1				
		15 ft.lb. (3 discs)	327212-3	1				
13,14, 15,16	Disc Plate Kit (Includes Disc & Pressure Plates)	3 & 6 ft.lb. (1 disc)	327212-1	1	20	Instruction Label		
		10 ft.lb. (2 discs)	327212-2	1				
		15 ft.lb. (3 discs)	327212-3	1				

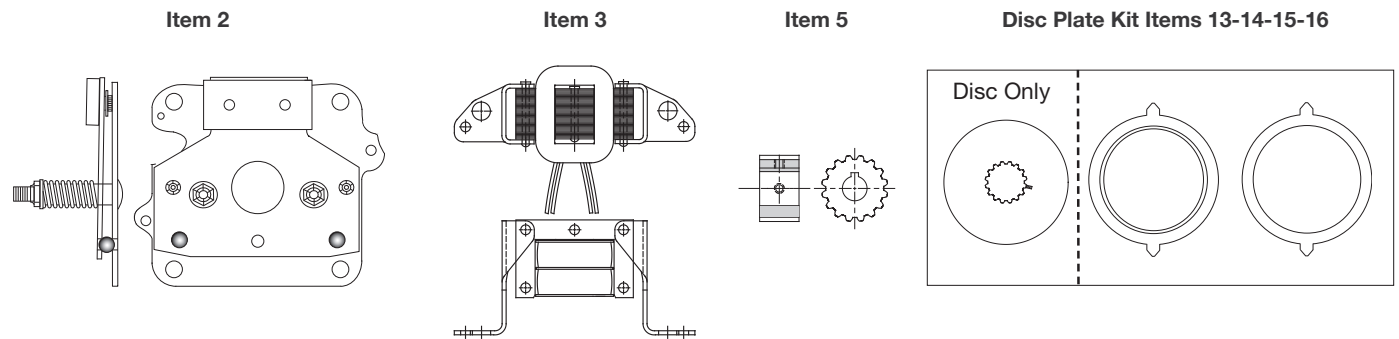

Service Parts

F-Series AC Rear-Mounted Brakes

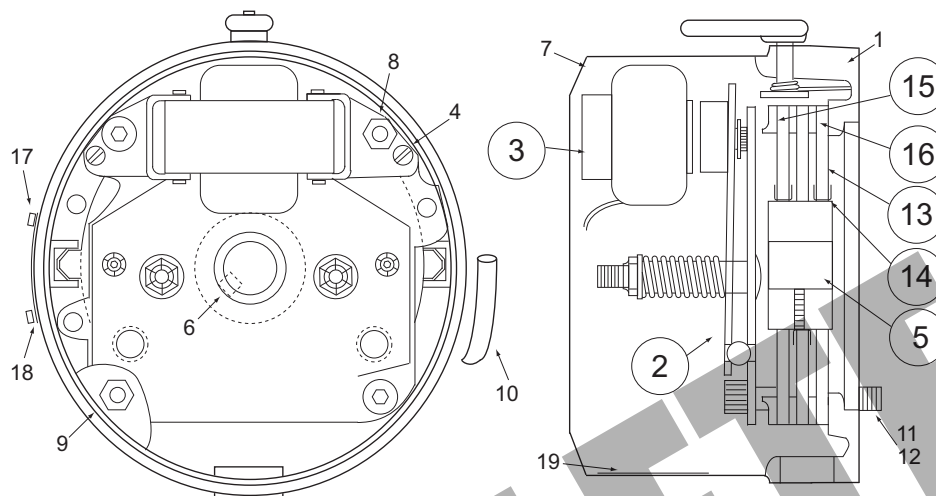

Component Parts

Item	Description	Part No.	Qty.	Item	Description	
2	Support & Armature Plate Assembly	6, 10, & 15 ft.lb.	79060-07-A	1	1	Brake Head Machined
		3 ft.lb.	79060-07-B	1		
		275/550V 60HZ	79137-18-G	1		
		230/460V 60HZ	79137-18-J	1		
3	Coil and Pole Assembly	115/230V 60HZ	79137-18-K	1	4	10-32 X 5/16 Slotted Hex Head With Split LW
		200/400V 60HZ	79137-18-L	1		
		208/416V 50HZ	79137-18-M	1		
		115/230V 50HZ	79137-18-N	1		
		230/460V 50HZ	79137-18-P	1		
5	Hub Assembly	5/8 Bore	58D22	1	5	Hub Assembly
		3/4 Bore	58D23	1		
		7/8 Bore	58D24	1		
13	Brake Disc (Individual)	327213	1	6	3/16" SQR X 1" Key	
13,14, 15,16	Disc Plate Kit (Includes Disc & Pressure Plates)	3 & 6 ft.lb. (1 disc)	327212-4			1
		10 ft.lb. (2 discs)	327212-5			1
		15 ft.lb. (3 discs)	327212-6			1
7	Brake Cover			7	Brake Cover	
8	Stud Extension					
9	10-32 Hex Nut			8	Stud Extension	
10	Insulating Sleeve					
11	3/8-16 X 2-1/2" Socket Cap Screw			9	10-32 Hex Nut	
12	3/8" Hi-Collar Lock Washer					
17	6-32 X 1/4" Hex Washer Head Screw			10	Insulating Sleeve	
18	Nameplate					
19	Instruction Label			11	3/8-16 X 2-1/2" Socket Cap Screw	
				12	3/8" Hi-Collar Lock Washer	
				17	6-32 X 1/4" Hex Washer Head Screw	
				18	Nameplate	
				19	Instruction Label	

Item 2

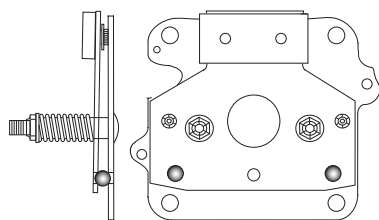

Item 3

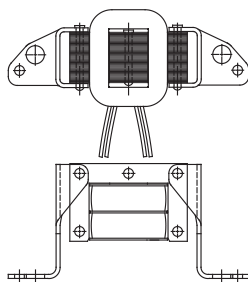

Item 5

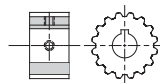

Disc Plate Kit Items 13-14-15-16

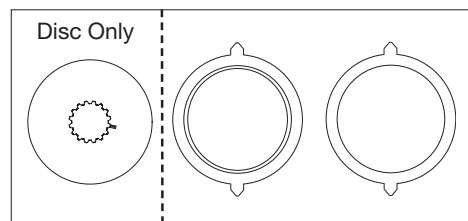

Service Parts

UNIBRAKES

F-Series AC Rear-Mounted Brakes

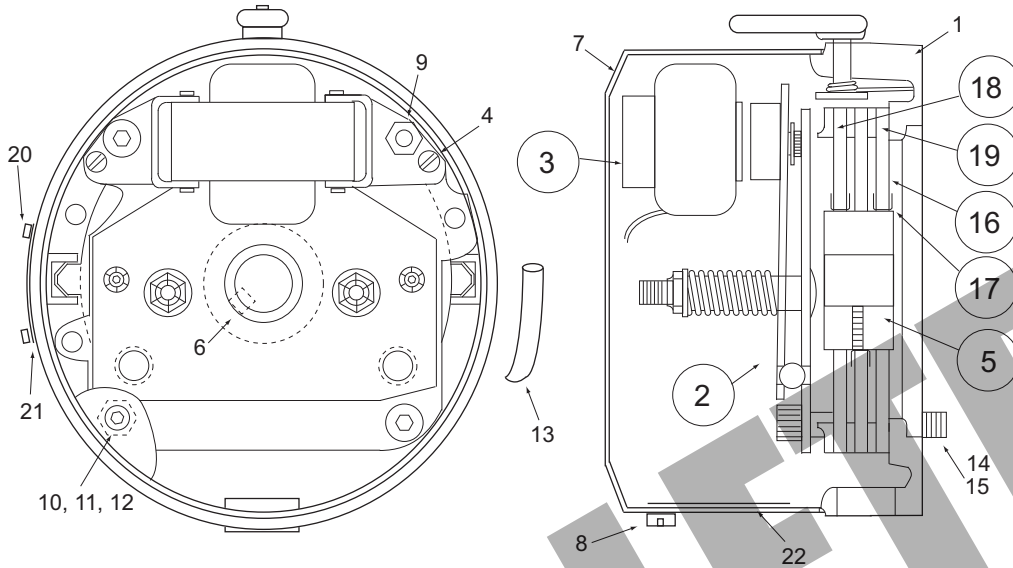

Component Parts

Item	Description	Part No.	Qty.	Item	Description
2	Support & Armature Plate Assembly 6, 10, & 15 ft.lb. 3 ft.lb.	79060-07-A	1	1	Brake Head Machined
		79060-07-B	1	4	10-32 X 5/16 Slotted Hex Head With Split LW
		79137-18-G	1	6	3/16" SQR X 1" Key
		79137-18-J	1	7	Brake Cover
		79137-18-K	1	8	Cover Plug
3	Coil and Pole Assembly	79137-18-L	1	9	Stud Extension
		79137-18-M	1	10	5/16" Split Lock Washer
		79137-18-N	1	11	10-32 X 5/8 Socket Head Cap Screw
		79137-18-P	1	12	#10 Flat Washer
		58D22	1	13	Insulating Sleeve
5	Hub Assembly	58D23	1	14	3/8-16 X 2-1/2" Socket Cap Screw
		58D24	1	15	3/8" Hi-Collar Lock Washer
		327213	1	16	Brake Disc (Individual)
16, 17	Disc Plate Kit	327212-4	1	17	Disc Plate Kit
		327212-5	1	18, 19	(Includes Disc & Pressure Plates)
		327212-6	1	20	9 Gage Escutcheon Pin
22	Instruction Label			21	Nameplate

Item 2

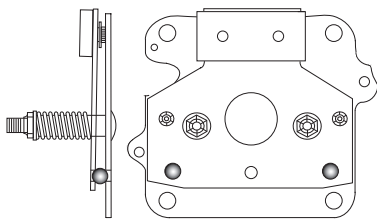

Item 3

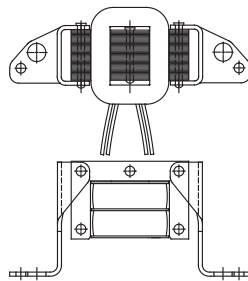

Item 5

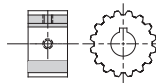

Disc Plate Kit Items 13-14-15-16

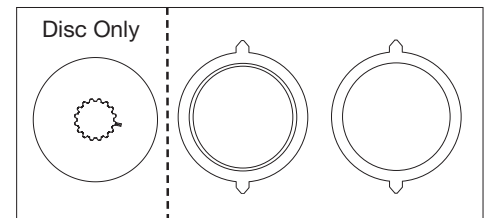

Service Parts

F-Series AC Rear-Mounted Brakes

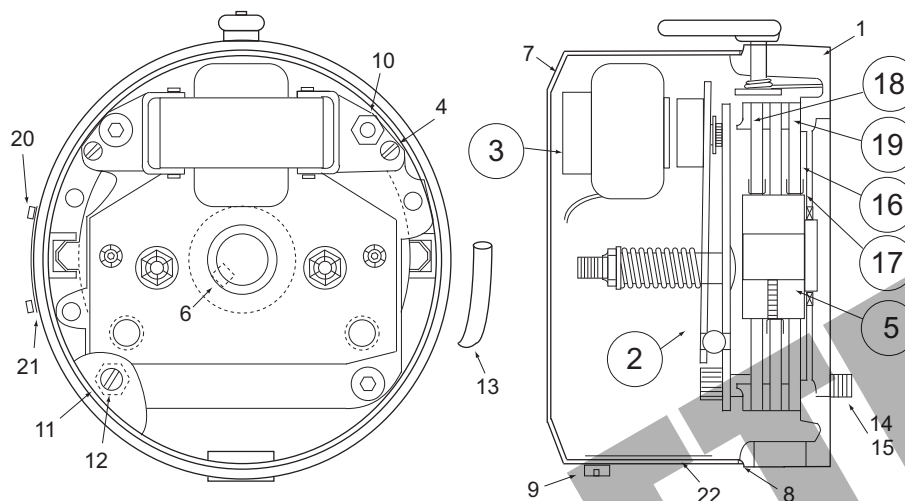

Component Parts

Item	Description	Part No.	Qty.	Item	Description	
2	Support & Armature Plate Assembly	6, 10, & 15 ft.lb.	79060-07-A	1	1	Brake Head Machined
		3 ft.lb.	79060-07-B	1		
		275/550V 60HZ	79137-18-G	1		
3	Coil and Pole Assembly	230/460V 60HZ	79137-18-J	1	4	10-32 X 5/16 Slotted Hex Head With Split LW
		115/230V 60HZ	79137-18-K	1		
		200/400V 60HZ	79137-18-L	1		
		208/416V 50HZ	79137-18-M	1		
		115/230V 50HZ	79137-18-N	1		
		230/460V 50HZ	79137-18-P	1		
5	Hub Assembly	5/8 Bore	58D29	1	6	3/16" SQR X 1" Key
		3/4 Bore	58D30	1		
		7/8 Bore	58D31	1		
16	Brake Disc (Individual)	327213	1	7	Brake Cover	
16, 17	Disc Plate Kit	3 & 6 ft.lb. (1 disc)	327212-4	1	8	Brake Cover Gasket
		10 ft.lb. (2 discs)	327212-5	1	9	Cover Plug
		15 ft.lb. (3 discs)	327212-6	1	10	Stud Extension
18, 19	(Includes Disc & Pressure Plates)	3 & 6 ft.lb. (1 disc)	327212-4	1	11	5/16" Split Lock Washer
		10 ft.lb. (2 discs)	327212-5	1	12	10-32 X 5/8" SS Pan Head With O-Ring
		15 ft.lb. (3 discs)	327212-6	1	13	Insulating Sleeve
				14	3/8-16 X 2-1/2" Socket Cap Screw	
				15	3/8" Hi-Collar Lock Washer	
				20	9 Gage Escutcheon Pin	
				21	Nameplate	
				22	Instruction Label	

Item 2

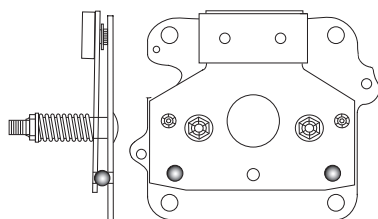

Item 3

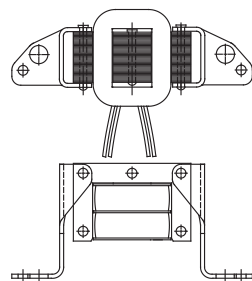

Item 5

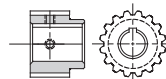

Disc Plate Kit Items 13-14-15-16

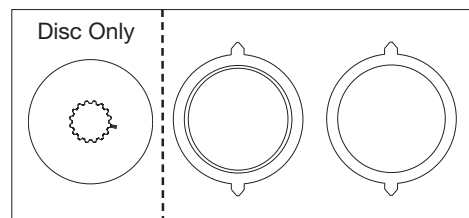

Service Parts

UNIBRAKES

M-Series AC Coupler Brakes

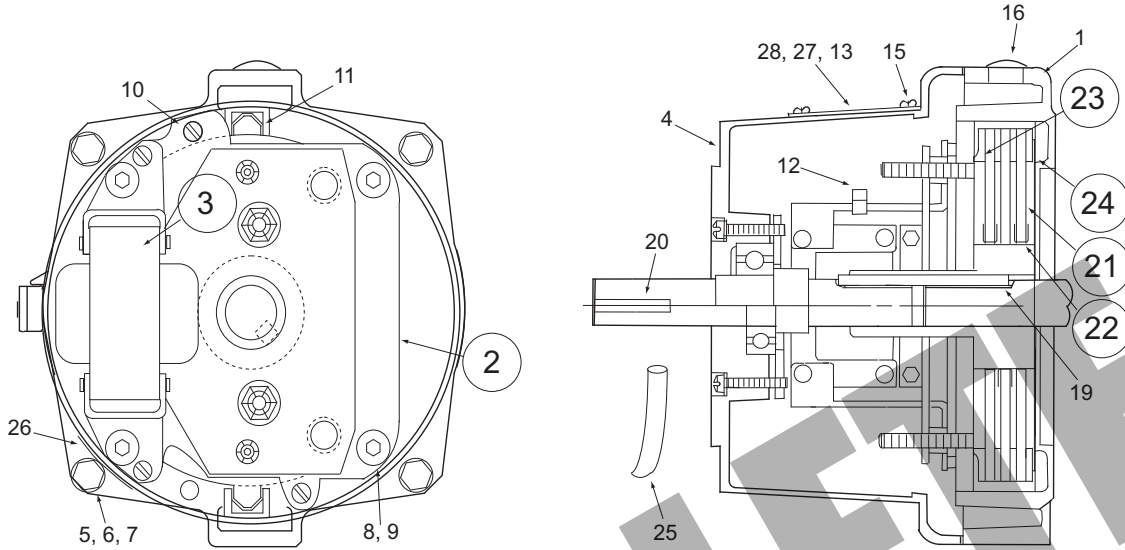

Component Parts

Item	Description	Part No.	Qty.	Item	Description
2	Support & Armature Plate Assembly	6, 10, & 15 ft.lb. 3 ft.lb.	1	1	Brake Head Machined
		79060-07-A	1	4	Brake Cover Assembly
		79060-07-B	1	5	1/4-20 X 1-1/2" Hex Cap Screw
		275/550V 60HZ	1	6	1/4" Split Lock Washer
		230/460V 60HZ	1	7	1/4-20 Hex Nut
		115/230V 60HZ	1	8	3/8-16 X 2-1/4" Socket Cap Screw
3	Coil and Pole Assembly	200/400V 60HZ	1	9	3/8" Hi-Collar Lock Washer
		208/416V 50HZ	1	10	1/4-20 X 3/8 Slotted Round Head Screw
		115/230V 50HZ	1	11	Anti Rattle Spacer
		230/460V 50HZ	1	12	Lead Clip
21	Brake Disc (Individual)	327213	1	13	Window Cover Plate
21,22	Disc Plate Kit	3 & 6 ft.lb. (1 disc)	1	15	6-32 X 1/4" Hex Washer Head Screw
23,24	(Includes Disc & Pressure Plates)	10 ft.lb. (2 discs)	1	16	1/2" Plug Button
				19	3/16" SQR X 2-3/4" Key
				20	3/16" SQR X 1-1/4" Key
				25	Insulating Sleeve
				26	Name Plate
				27	Instruction Label - Gap
				28	Instruction Label - Wire

Item 2

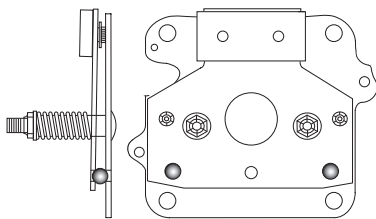

Item 3

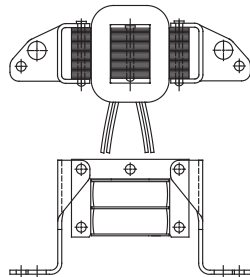

Disc Plate Kit Items 13-14-15-16

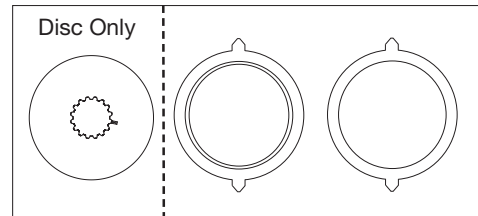

Service Parts

M-Series DC Coupler Brakes

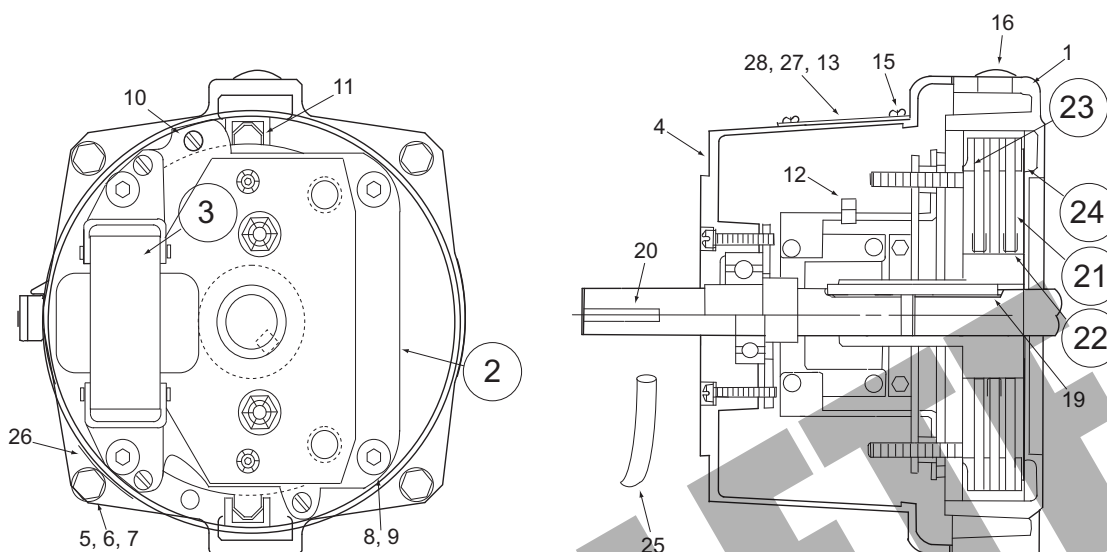

Component Parts

Item	Description	Part No.	Qty.	Item	Description
2	Support & Armature Plate Assembly	79060-07-A	1	1	Brake Head Machined
3	Coil and Pole Assembly	327208	1	4	Brake Cover Assembly
		327209	1	5	1/4-20 X 1-1/2" Hex Cap Screw
21	Brake Disc (Individual)	327213	1	6	1/4" Split Lock Washer
21,22	Disc Plate Kit	327212-1	1	7	1/4-20 Hex Nut
23,24	(Includes Disc & Pressure Plates)	327212-2	1	8	3/8-16 X 2-1/4" Socket Cap Screw
		327212-3	1	9	3/8" Hi-Collar Lock Washer
				10	1/4-20 X 3/8 Slotted Round Head Screw
				11	Anti Rattle Spacer
				12	Lead Clip
				13	Window Cover Plate
				15	6-32 X 1/4" Hex Washer Head Screw
				16	1/2" Plug Button
				19	3/16" SQR X 2-3/4" Key
				20	3/16" SQR X 1-1/4" Key
				25	Insulating Sleeve
				26	Name Plate
				27	Instruction Label - Gap
				28	Instruction Label - Wire

Item 2

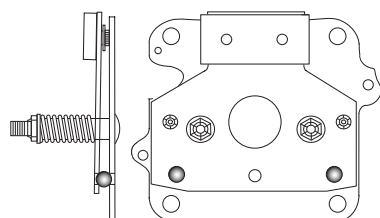

Item 3

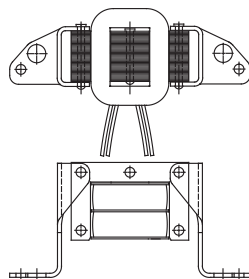

Disc Plate Kit Items 13-14-15-16

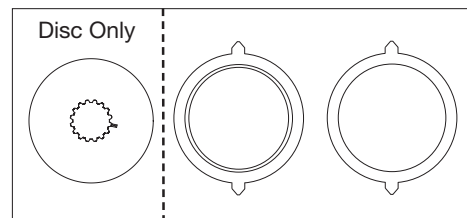

Service Parts

Part Numbers Ordering Information

C-face Compatible Units

Electro Modules - EM

Description	Model	Part No.	Voltage	Pg. No.	
Motor Clutch Module	EM-50-10	5370-270-201	6	24	
		5370-270-203	24		
		5370-270-204	90		
	EM-100-10	5370-270-206	6	24	
		5370-270-208	24		
		5370-270-209	90		
	EM-180-10	5370-270-211	6	24	
		5370-270-213	24		
		5370-270-214	90		
	EM-210-10	5371-270-011	6	24	
		5371-270-027	24		
		5371-270-009	90		
Brake Module	EM-50-20	5370-169-201	6	24	
		5370-169-203	24		
		5370-169-204	90		
	EM-100-20	5370-169-206	6	24	
		5370-169-208	24		
		5370-169-209	90		
	EM-180-20	5370-169-211	6	24	
		5370-169-213	24		
		5370-169-214	90		
	EM-210-20	5371-169-022	6	24	
		5371-169-034	24		
		5371-169-023	90		
EM-215-20	5371-169-076	90	24		
	5370-169-216	6			
	5370-169-218	24			
Motor Brake	EM-50-20MB	5370-169-219	90	24	
		5370-169-221	6		
		5370-169-223	24		
	EM-180-20MB	5370-169-224	90	24	
		5371-169-025	6		
		5371-169-035	24		
EM-210-20MB	5371-169-026	90	24		
	5370-270-216	6			
	5370-270-218	24			
Input Clutch Module	EM-50-30	5370-270-219	90	24	
		5370-270-221	6		
		5370-270-223	24		
	EM-100-30	5370-270-224	90	24	
		5370-270-226	6		
		5370-270-228	24		
	EM-180-30	5370-270-229	90	24	
		5371-270-023	6		
		5371-270-026	24		
	EM-210-30	5371-270-024	90	24	
		5370-536-200	-		24
		5370-536-201			
5370-536-202					
Output Clutch Module	EM-210-40	5371-536-005		24	

UniModules - UM

Description	Model	Part No.	Voltage	Pg. No.
Clutch/Brake UniModule Fully Assembled Brake/Clutch Unit	UM-50-1020	5370-273-201	6	14
		5370-273-203	24	
		5370-273-204	90	
	UM-50-2030	5370-273-216	6	14
		5370-273-218	24	
		5370-273-219	90	
	UM-100-1020	5370-273-206	6	14
		5370-273-208	24	
		5370-273-209	90	
	UM-100-2030	5370-273-221	6	14
		5370-273-223	24	
		5370-273-224	90	
UM-180-1020	5370-273-211	6	14	
	5370-273-213	24		
	5370-273-214	90		
UM-180-1020 Heavy-Duty	5370-273-323	90	14	
	5370-273-226	6		
	5370-273-228	24		
UM-180-2030	5370-273-229	90	14	
	5371-273-002	6		
	5371-273-004	24		
UM-210-1020	5371-273-003	90	14	
	5371-273-007	6		
	5371-273-009	24		
UM-210-2030	5371-273-008	90	14	
	5371-273-076	6		
	5371-273-077	24		
UM-215-1020	5371-273-078	90	14	
	5371-273-043	6		
	5371-273-044	24		
UM-215-2030	5371-273-045	90	14	
	5370-271-201	6		
	5370-271-203	24		
Clutch UniModule Fully Assembled Clutch Unit	UM-50-1040	5370-271-204	90	14
		5370-271-216	6	
		5370-271-218	24	
UM-50-3040	5370-271-219	90	14	
	5370-271-206	6		
	5370-271-208	24		
UM-100-1040	5370-271-209	90	14	
	5370-271-221	6		
	5370-271-223	24		
UM-100-3040	5370-271-224	90	14	
	5370-271-211	6		
	5370-271-213	24		
UM-180-1040	5370-271-214	90	14	
	5370-271-226	6		
	5370-271-228	24		
UM-180-3040	5370-271-229	90	14	
	5371-271-002	6		
	5371-271-004	24		
UM-210-1040	5371-271-003	90	14	
	5371-271-007	6		
	5371-271-009	24		
UM-210-3040	5371-271-008	90	14	
	5371-271-026	6		
	5371-271-027	24		
UM-215-1040	5371-271-028	90	14	
	5371-271-021	6		
	5371-271-022	24		
UM-215-3040	5371-271-023	90	14	
	5370-273-230	90		
	5370-273-231	90		
UM 1020 with Pre-Installed Controls	UM-180-1020	5370-273-232	90	14
	UM-180-1020 Heavy-Duty	5370-237-324	90	
	UM-210-1020	5371-4	90	
(CBC 150-1)	UM-215-1020	5371-273-090	90	

Part Numbers Ordering Information

C-face Compatible Units

UniModules – Ceramic Faced – UM-C

Description	Model	Part No.	Voltage	Pg. No.
C-face Mount	UM-50-1020-C	5370-273-271	6	42
		5370-273-273	24	
		5370-273-274	90	
	UM-180-1020-C	5370-273-276	6	42
		5370-273-278	24	
		5370-273-279	90	
UM-210-1020-C	5371-273-035	6	42	
	5371-273-036	24		
	5371-273-037	90		
Base/Foot Mount	UM-50-2030-C	5370-273-281	6	42
		5370-273-283	24	
		5370-273-284	90	
	UM-180-2030-C	5370-273-286	6	42
		5370-273-288	24	
		5370-273-289	90	
	UM-210-2030-C	5371-273-039	6	42
		5371-273-040	24	
		5371-273-041	90	

Smooth-Start UniModules

Description	Model	Part No.	Voltage	Pg. No.
Smooth-Start	UM-50-1020	5370-273-236	90	40
	UM-100-1020	5370-273-237	90	40
	UM-180-1020	5370-273-238	90	40
	UM-210-1020	5371-273-103	90	40
	UM-215-1020	5371-273-080	90	40

Enclosed UniModules – EUM

Description	Model	Part No.	Voltage	Pg. No.	
C-face Mount	EUM-50-1020	5370-15	6	39, 49	
		5370-16	24		
		5370-17	90		
	EUM-50-1040	5370-24	90	39, 49	
		5370-18	6	39, 49	
		5370-19	24		
	5370-20	90			
	EUM-100-1020	5370-21	6	39, 49	
		5370-22	24		
		5370-23	90		
	EUM-180-1040	5370-25	90	39, 49	
		5371-273-028	6	51	
		5371-273-029	24		
	5371-273-027	90			
	EUM-210-1040	5371-271-024	90	51	
		5371-273-082	6	51	
		5371-273-083	24		
	5371-273-084	90			
	Base/Foot Mount	EUM-50-2030	5370-26	6	39, 49
			5370-27	24	
			5370-28	90	
EUM-180-2030		5370-29	6	39, 49	
		5370-30	24		
		5370-31	90		
EUM-210-2030		5371-273-032	6	51	
		5371-273-033	24		
		5371-273-031	90		

Accessories for EM, UM, UM-C and EUM

Description	Model	Part No.	Voltage	Pg. No.
Conduit Box	All Sizes	5370-101-042		18
Controls	CBC-150-1	6004-448-001	110 VAC	204
	CBC-150-2	6004-448-002	220 VAC	204
Base Mount Kits for 2030 and 3040	EM/UM-50/100	5370-101-004	—	18
	EM/UM-180	5370-101-002		18
	EM/EUM/UM-210 EM/EUM/UM-215	5371-101-001		54
Motor Mount Kits for 20, 1020, 1040	EM/UM-50/100	5370-101-078	—	54
	EM/UM-180 EUM-50/100/180	5370-101-079		54
	EM/EUM/UM-210 EM/EUM/UM-215	5371-101-012		54
Fan Kits for 1020	EUM-50/100	5370-101-055		54
	UM-50-C			
	EUM-180 UM-180-C	5370-101-054		54
	EUM-210 UM-210-C	5371-101-029		54

Enclosed UniModules – Washdown Models – EUM-W

Description	Model	Part No.	Voltage	Pg. No.
C-face Mount	EUM-50-1020W	5370-273-100	6	60
		5370-273-101	24	
		5370-273-099	90	
	EUM-100-1020W	5370-273-108	6	60
		5370-273-109	24	
		5370-273-107	90	
	EUM-180-1020W	5370-273-116	6	60
		5370-273-117	24	
		5370-273-115	90	
	EUM-210-1020W	5371-273-056	6	60
		5371-273-057	24	
		5371-273-055	90	
	EUM-215-1020W	5371-273-086	6	60
		5371-273-087	24	
		5371-273-088	90	
Base/Foot Mount	EUM-50-2030W	5370-273-104	6	60
		5370-273-105	24	
		5370-273-103	90	
	EUM-180-2030W	5370-273-120	6	60
		5370-273-121	24	
		5370-273-119	90	
	EUM-210-2030W	5371-273-060	6	60
		5371-273-061	24	
		5371-273-059	90	

Accessories for EUM-W

Conduit Box	All Sizes	5370-101-045		63
Controls	CBC-150-1	6004-448-001	110 VAC	204
	CBC-150-2	6004-448-002	220 VAC	204
Base Mount	EUM-50W/180W	5370-101-047		63
Motor Mount	EUM-210W	5371-101-025		63
Fan Kits	EUM-50W EUM-100W EUM-180W	5370-101-080		63
	EUM-210W EUM-215W	5371-101-026		63
	EUM-50W/100W EUM-180W EUM-210W	5370-101-060 5370-101-061 5371-101-033		63 63 63

Part Numbers Ordering Information

Shaft Mounted Units

Electro Clutches - EC

Description	Model	Part No.	Voltage	Pg. No.	
EC-375	EC-375-1/2	5180-271-006	6	67	
		5180-271-004	24		
		5180-271-009	90		
	EC-375-5/8	5180-271-002	6		
		5180-271-008	24		
		5180-271-005	90		
EC-475	EC-475-5/8	5181-271-033	6	67	
		5181-271-037	24		
		5181-271-036	90		
	EC-475-3/4	5181-271-032	6		
		5181-271-038	24		
		5181-271-034	90		
EC-475-7/8	5181-271-031	6	67		
	5181-271-039	24			
	5181-271-035	90			
EC-650	EC-650-1	5281-271-004	6	67	
		5281-271-018	24		
		5281-271-007	90		
	EC-650-1-1/8	5281-271-002	6		67
		5281-271-019	24		
		5281-271-005	90		
	EC-650-1-1/4	5281-271-009	6		67
		5281-271-020	24		
		5281-271-008	90		
	EC-650-1-3/8	5281-271-003	6		67
		5281-271-016	24		
		5281-271-006	90		
EC-825	EC-825-1-1/8	5282-271-002	6	67	
		5282-271-008	24		
		5282-271-011	90		
	EC-825-1-1/4	5282-271-003	6		67
		5282-271-009	24		
		5282-271-012	90		
EC-825-1-3/8	5282-271-004	6	67		
	5282-271-010	24			
	5282-271-013	90			
EC-1000	EC-1000-1-3/8	5283-271-002	6	67	
		5283-271-010	24		
		5283-271-003	90		
	EC-1000-1-1/2	5283-271-012	24		67
		5283-271-013	90		
		5283-271-004	6		
EC-1000-1-5/8	5283-271-011	24	67		
	5283-271-005	90			
	5283-271-004	6			
EC-1225	EC-1225-1-5/8	5284-271-008	6	67	
		5284-271-013	24		
		5284-271-010	90		
	EC-1225-1-7/8	5284-271-002	6		67
		5284-271-014	24		
		5284-271-003	90		
EC-1225-2-1/8	5284-271-004	6	67		
	5284-271-015	24			
	5284-271-005	90			

Electro Brakes - EB

Description	Model	Part No.	Voltage	Pg. No.	
EB-375	EB-375-1/2	5380-170-005	6	74	
		5380-170-006	24		
		5380-170-004	90		
	EB-375-5/8	5380-170-003	6		74
		5380-170-007	24		
		5380-170-002	90		
EB-475	EB-475	5381-170-003	6	74	
		5381-170-004	24		
		5381-170-002	90		
EB-650	EB-650	5382-170-003	6	74	
		5382-170-005	24		
		5382-170-002	90		
EB-825	EB-825	5383-170-002	6	74	
		5383-170-004	24		
		5383-170-005	90		
EB-1000	EB-1000	5384-170-003	6	74	
		5384-170-005	24		
		5384-170-002	90		
EB-1225	EB-1225	5385-170-003	6	74	
		5385-170-005	24		
		5385-170-002	90		

Adapters for Electro Brakes

Adapter No.	Part Number	Pg. No.
375-3/8	5380-101-005	79
375-7/8	5380-101-004	79
475-1-1/8	5381-101-003	79
650-1-3/8	5382-101-003	79
650-1-5/8	5382-101-002	79
1000-1-5/8	5384-101-008	79
1000-1-7/8	5384-101-007	79
1000-2-1/8	5384-101-010	79
1225-2-1/8	5385-101-008	79
1225-2-3/8	5383-101-007	79

Bushings for Electro Brakes

Bushing No.	Part Number	Pg. No.
1008	Specify Bore Size	198
	180-0410 to 180-0418	
1310	Specify Bore Size	198
	180-0421 to 180-0435	
H-1, H-2	Specify Bore Size	198
	180-0002 to 180-0018	
1615	Specify Bore Size	198
	180-0131 to 180-0149	
2517	Specify Bore Size	198
	180-0185 to 180-0217	

Part Numbers Ordering Information

Shaft Mounted Units

AT Clutches - ATC

Description	Model	Part No.	Voltage	Pg. No.
ATC-25	ATC-25-1/2	5161-271-002	6	80
		5161-271-010	24	
		5161-271-003	90	
	ATC-25-5/8	5161-271-004	6	80
		5161-271-011	24	
		5161-271-005	90	
ATC-25-3/4	5161-271-006	6	80	
	5161-271-012	24		
	5161-271-007	90		
ATC-25-7/8	5161-271-008	6	80	
	5161-271-013	24		
	5161-271-009	90		
ATC-55	ATC-55-3/4	5162-271-002	6	80
		5162-271-010	24	
		5162-271-003	90	
	ATC-55-7/8	5162-271-004	6	80
		5162-271-011	24	
		5162-271-005	90	
ATC-55-1	5162-271-006	6	80	
	5162-271-012	24		
	5162-271-007	90		
ATC-55-1-1/8	5162-271-008	6	80	
	5162-271-013	24		
	5162-271-009	90		
ATC-115	ATC-115-1-1/8	5163-271-002	6	80
		5163-271-010	24	
		5163-271-003	90	
	ATC-115-1-1/4	5163-271-004	6	80
		5163-271-011	24	
		5163-271-005	90	
	ATC-115-1-3/8	5163-271-006	6	80
		5163-271-012	24	
		5163-271-007	90	
	ATC-115-1-1/2	5163-271-008	6	80
		5163-271-013	24	
		5163-271-009	90	

AT Brakes - ATB

Description	Model	Part No.	Voltage	Pg. No.
ATB-25	ATB-25-1/2	5191-170-002	6	80
		5191-170-010	24	
		5191-170-003	90	
	ATB-25-5/8	5191-170-004	6	80
		5191-170-011	24	
		5191-170-005	90	
ATB-25-3/4	5191-170-006	6	80	
	5191-170-012	24		
	5191-170-007	90		
ATB-25-7/8	5191-170-008	6	80	
	5191-170-013	24		
	5191-170-009	90		
ATB-55	ATB-55-3/4	5192-170-002	6	80
		5192-170-010	24	
		5192-170-003	90	
	ATB-55-7/8	5192-170-004	6	80
		5192-170-011	24	
		5192-170-005	90	
ATB-55-1	5192-170-006	6	80	
	5192-170-012	24		
	5192-170-007	90		
ATB-55-1-1/8	5192-170-008	6	80	
	5192-170-013	24		
	5192-170-009	90		
ATB-115	ATB-115-1-1/8	5193-170-002	6	80
		5193-170-010	24	
		5193-170-003	90	
	ATB-115-1-1/4	5193-170-004	6	80
		5193-170-011	24	
		5193-170-005	90	
	ATB-115-1-3/8	5193-170-006	6	80
		5193-170-012	24	
		5193-170-007	90	
	ATB-115-1-1/2	5193-170-008	6	80
		5193-170-013	24	
		5193-170-009	90	

Stationary Field Clutches - SFP

Description	Model	Part No.	Voltage	Pg. No.
SFP-180	SFP-180-1/4	SFP180-14-24	24	92
		SFP180-516-24	24	
		SFP180-38-24	24	
	SFP-180-1/4	SFP180-14-90	90	92
		SFP180-516-90	90	
		SFP180-38-90	90	
SFP-250	SFP-250-3/8	5103-271-002	6	90
		5103-271-006	24	
		5103-271-010	90	
	SFP-250-7/16	5103-271-003	6	90
		5103-271-007	24	
		5103-271-011	90	
	SFP-250-1/2	5103-271-004	6	90
		5103-271-008	24	
		5103-271-012	90	
	SFP-250-5/8	5103-271-005	6	90
		5103-271-009	24	
		5103-271-013	90	
SFP-325	SFP-325-1/2	SFP325-12-24	24	93
		SFP325-12-90	90	

Description	Model	Part No.	Voltage	Pg. No.
SFP-400	SFP-400-1/2	5104-271-006	6	90
		5104-271-016	24	
		5104-271-021	90	
		5104-271-007	6	
		5104-271-017	24	
		5104-271-022	90	
	SFP-400-5/8	5104-271-008	6	90
		5104-271-018	24	
		5104-271-023	90	
	SFP-400-3/4	5104-271-009	6	90
		5104-271-019	24	
		5104-271-024	90	
SFP-400-7/8	5104-271-010	6	90	
	5104-271-020	24		
	5104-271-025	90		

Part Numbers Ordering Information

Base Mounted Units

Electro Pack - EP

Model	Part No.	Voltage	Pg. No.
EP-170	5633-273-002	6	94
	5633-273-003	24	
	5633-273-005	90	
EP-250	5130-273-031	6	94
	5130-273-032	24	
	5130-273-034	90	
EP-400	5131-273-009	6	94
	5131-273-010	24	
	5131-273-011	90	
EP-500	5230-273-003	6	94
	5230-273-011	24	
	5230-273-002	90	
EP-825	5231-273-003	6	94
	5231-273-004	24	
	5231-273-002	90	
EP-1000	5232-273-003	6	94
	5232-273-005	24	
	5232-273-002	90	
EP-1525	5234-273-003	6	94
	5234-273-002	90	
	EP-1525HT	5234-273-017	
5234-273-012		90	

Electro Pack – Ceramic Faced - EP-C

Model	Part No.	Voltage	Pg. No.
EP-170-C	5633-273-018	24	100
	5633-273-019	90	
EP-250-C	5130-273-053	24	100
	5130-273-054	90	

Electro Pack – Washdown

Model	Part No.	Voltage	Pg. No.
EP-250-W	5130-273-060	24	104
	5130-273-061	90	
EP-400-W	5131-273-030	24	104
	5131-273-031	90	

Spring-Set Brakes (Static Holding) - ERS

Description	Model	Part No.	Voltage	Pg. No.
ERS	ERS-26	5158-170-016	24	109
		5158-170-015	90	
ERS	ERS-42	5151-170-002	24	109
		5151-170-001	90	
ERS	ERS-49	5155-170-002	24	109
		5155-170-001	90	
ERS	ERS-57	5153-170-003	24	109
		5153-170-002	90	
ERS	ERS-68	5154-170-002	24	109
		5154-170-001	90	

ERS Mounting Flanges (Optional)

Model	Part No.	Pg. No.
ERS-26	686-0182	113
ERS-42	686-0183	113
ERS-49	686-0184	113
ERS-57	686-0185	113
ERS-68	686-0186	113

Spring-Set Electrically Released Brakes

ERS Splined Hubs - ERS

Model	Bore Size	Part No.	Pg. No.
ERS-26	.250	5158-541-006	112
	.312	5158-541-007	112
	.375	5158-541-008	112
ERS-42	.375	5151-541-002	112
	.500	5151-541-003	112
	.625	5151-541-004	112
ERS-49	.750	5151-541-005	112
	.375	5155-541-002	112
	.500	5155-541-003	112
ERS-49	.625	5155-541-004	112
	.750	5155-541-005	112
	.875	5155-541-006	112
ERS-57	.500	5153-541-004	112
	.625	5153-541-005	112
	.750	5153-541-006	112
ERS-57	.875	5153-541-007	112
	1.000	5153-541-008	112
	1.000	5154-541-005	112
ERS-68	1.125	5154-541-006	112
	1.250	5154-541-007	112
	1.375	5154-541-008	112
ERS-68	1.500	5154-541-009	112
	Conduit Box	5154-101-001	112

EM/ERS Spring-Set Brake Modules

Model	Part No.	Voltage	Pg. No.
EM-50/ERS-42	5370-170-201	24	117
	5370-170-203	90	
EM-50/ERS-49	5370-170-206	24	117
	5370-170-207	90	
EM-180/ERS-57	5370-170-211	24	117
	5370-170-212	90	
EM-210/ERS-68	5371-170-042	24	117
	5371-170-043	90	

Spring-Set Brakes - ERD

Model	Part No.	Pg. No.
ERD 5		121
ERD 10		121
ERD 20		121
ERD 35		121
ERD 60		121
ERD 100		121
ERD 170		121
ERD 300		121
ERD Rectifiers	ACG830A1P1	130
	ACG830A1P2	130

Part Numbers Ordering Information

Electrically Released Brakes- Permanent Magnet

Permanent Magnet Brakes (Dynamic Cycling)

Description	Model	Part No.	Voltage	Pg. No.	
FB	FB-375-1/2	5390-170-021	90	134	
		5390-170-024	24		
	FB-375-5/8	5390-170-022	90	134	
		5390-170-023	24		
	FB-475	5391-170-009	90	134	
		5391-170-012	24		
	FB-650	5392-170-007	90	134	
		5392-170-010	24		
	ER	ER-375	Drawing I-25766	90	138
		ER-475	Drawing I-25755	90	138
ER-650		Drawing I-25767	90	138	
ER-825 (N.D.)		Drawing I-25577	90	138	
ER-825 (H.D.)		Drawing I-25578	90	138	
ER-1225 (N.D.)		Drawing I-25619	36-75	138	
ER-1225 (H.D.)		Drawing I-25620	35-75	138	

UniModules - UM-FBC

Description	Model	Part No.	Voltage	Pg. No.
Clutch/Brake UniModules	UM-50-1020FBC	5370-273-243	24	144
		5370-273-244	90	
	UM-100-1020FBC	5370-273-248	24	144
		5370-273-249	90	
	UM-180-1020FBC	5370-273-253	24	144
		5370-273-254	90	
	UM-210-1020FBC	5371-273-013	24	144
		5371-273-012	90	
	UM-215-1020FBC	5371-273-099	24	144
		5371-273-079	90	
	UM-50-2030FBC	5370-273-258	24	144
		5370-273-259	90	
	UM-100-2030FBC	5370-273-263	24	144
		5370-273-264	90	
	UM-180-2030FBC	5370-273-268	24	144
		5370-273-269	90	
	UM-210-2030FBC	5371-273-018	24	144
		5371-273-017	90	
	UM-215-2030FBC	5371-273-100	24	144
		5371-273-101	90	

Accessories for UM-FBC, EUM-FBB/MBFB, and EM-FBB/FBC/MBFB

Description	Model	Part No.	Voltage	Pg. No.
Conduit Box	All Sizes	5370-101-042		63
Controls All Sizes	CBC-160-1	6013-448-001	120 VAC	205
	CBC-160-2	6013-448-002	220 VAC	205
Base Mount Kits 2030 (FB only)	UM-50/100	5370-101-004	—	150
	UM-180	5370-101-002		150
	UM-210/215	5371-101-019		150
Motor Mount Kits for 20FBB and 1020FBC	EM/UM-50/100	5370-101-078	—	149
	EM/UM-180			149
	EUM-50/100/180	5370-101-079		
	EM/EUM/UM-210 EM/EUM/UM-215	5371-101-012		149

Shaft Mounted, Flange Mounted and C-face Compatible Units

Electro Modules

Description	Model	Part No.	Voltage	Pg. No.
Brake Module	EM-50-20FBB	5370-169-278	24	159
		5370-169-279	90	
	EM-100-20FBB	5370-169-283	24	159
		5370-169-284	90	
	EM-180-20FBB	5370-169-288	24	159
		5370-169-289	90	
	EM-210-20FBB	5371-169-032	24	159
		5371-169-029	90	
	EM-215-20FBB	5371-169-100	24	159
		5371-169-054	90	
	EM-50-20FBC	5370-169-233	24	159
		5370-169-234	90	
	EM-100-20FBC	5370-169-238	24	159
		5370-169-239	90	
	EM-180-20FBC	5370-169-243	24	159
5370-169-244		90		
EM-210-20FBC	5371-169-031	24	159	
	5371-169-028	90		
Motor Brake	EM-50-20MBFB	5370-169-248	24	159
		5370-169-249	90	
	EM-100-20MBFB	5370-169-253	24	159
		5370-169-254	90	
	EM-180-20MBFB	5370-169-258	24	159
		5370-169-259	90	
	EM-210-7/8-20MBFB	5371-169-101	24	159
		5371-169-072	90	
	EM-210-20MBFB	5371-169-033	24	159
		5371-169-030	90	

Enclosed UniModules

Description	Model	Part No.	Voltage	Pg. No.		
Brake Module	EUM-50-20FBB-6	5370-169-260	90	152		
		5370-32	90	152		
		5370-169-261	90	152		
		5370-33	90	152		
		5370-169-262	90	152		
		5370-34	90	152		
		5371-169-078	90	152		
		5371-169-082	90	152		
		5371-169-086	90	152		
		5371-169-090	90	152		
		Motor Brake	EUM-50-20MBFB-6	5370-169-263	90	152
				5370-35	90	152
				5370-169-264	90	152
				5370-36	90	152
				5370-169-265	90	152
5370-37	90			152		
5371-169-064	90			152		
5371-169-068	90			152		
5371-169-056	90			152		
5371-169-060	90			152		

Index

Page	Model Number	Part Number	Service Parts Page
92	SFP 180	SFP180-14-24	NA
92	SFP 180	SFP180-516-24	NA
92	SFP 180	SFP180-38-24	NA
92	SFP 180	SFP180-14-90	NA
92	SFP 180	SFP180-516-90	NA
92	SFP 180	SFP180-38-90	NA
90	SFP 250	5103-271-002	NA
90	SFP 250	5103-271-003	NA
90	SFP 250	5103-271-004	NA
90	SFP 250	5103-271-005	NA
90	SFP 250	5103-271-006	NA
90	SFP 250	5103-271-007	NA
90	SFP 250	5103-271-008	NA
90	SFP 250	5103-271-009	NA
90	SFP 250	5103-271-010	NA
90	SFP 250	5103-271-011	NA
90	SFP 250	5103-271-012	NA
90	SFP 250	5103-271-013	NA
93	SFP 325	SFP325-12-24	NA
93	SFP 325	SFP325-12-90	NA
90	SFP 400	5104-271-006	NA
90	SFP 400	5104-271-007	NA
90	SFP 400	5104-271-008	NA
90	SFP 400	5104-271-009	NA
90	SFP 400	5104-271-010	NA
90	SFP 400	5104-271-016	NA
90	SFP 400	5104-271-017	NA
90	SFP 400	5104-271-018	NA
90	SFP 400	5104-271-019	NA
90	SFP 400	5104-271-020	NA
90	SFP 400	5104-271-021	NA
90	SFP 400	5104-271-022	NA
90	SFP 400	5104-271-023	NA
90	SFP 400	5104-271-024	NA
90	SFP 400	5104-271-025	NA
94	EP250	5130-273-031	286
94	EP250	5130-273-032	286
94	EP250	5130-273-034	286
100	EP250C	5130-273-053	
100	EP250C	5130-273-054	
104	EP250W	5130-273-060	
104	EP250W	5130-273-061	
94	EP400	5131-273-009	286
94	EP400	5131-273-010	286
94	EP400	5131-273-011	286
104	EP400W	5131-273-030	
104	EP400W	5131-273-031	
109	ERS 42	5151-170-001	
109	ERS 42	5151-170-002	
109	ERS 42	5151-541-002	
109	ERS 42	5151-541-003	
109	ERS 42	5151-541-004	
109	ERS 42	5151-541-005	
109	ERS 57	5153-170-002	
109	ERS 57	5153-170-003	
109	ERS 57	5153-541-004	
109	ERS 57	5153-541-005	
109	ERS 57	5153-541-006	
109	ERS 57	5153-541-007	
109	ERS 57	5153-541-008	
109	ERS 68	5154-170-001	
109	ERS 68	5154-170-002	
109	ERS 68	5154-541-005	
109	ERS 68	5154-541-006	
109	ERS 68	5154-541-007	
109	ERS 68	5154-541-008	

Page	Model Number	Part Number	Service Parts Page
109	ERS 68	5154-541-009	
109	ERS 49	5155-170-001	
109	ERS 49	5155-170-002	
109	ERS 49	5155-541-002	
109	ERS 49	5155-541-003	
109	ERS 49	5155-541-004	
109	ERS 49	5155-541-005	
109	ERS 49	5155-541-006	
109	ERS 26	5158-170-015	
109	ERS 26	5158-170-016	
109	ERS 26	5158-541-006	
109	ERS 26	5158-541-007	
109	ERS 26	5158-541-008	
80	ATC25	5161-271-002	282
80	ATC25	5161-271-003	282
80	ATC25	5161-271-004	282
80	ATC25	5161-271-005	282
80	ATC25	5161-271-006	282
80	ATC25	5161-271-007	282
80	ATC25	5161-271-008	282
80	ATC25	5161-271-009	282
80	ATC25	5161-271-010	282
80	ATC25	5161-271-011	282
80	ATC25	5161-271-012	282
80	ATC25	5161-271-013	282
80	ATC55	5162-271-002	282
80	ATC55	5162-271-003	282
80	ATC55	5162-271-004	282
80	ATC55	5162-271-005	282
80	ATC55	5162-271-006	282
80	ATC55	5162-271-007	282
80	ATC55	5162-271-008	282
80	ATC55	5162-271-009	282
80	ATC55	5162-271-010	282
80	ATC55	5162-271-011	282
80	ATC55	5162-271-012	282
80	ATC55	5162-271-013	282
80	ATC115	5163-271-002	282
80	ATC115	5163-271-003	282
80	ATC115	5163-271-004	282
80	ATC115	5163-271-005	282
80	ATC115	5163-271-006	282
80	ATC115	5163-271-007	282
80	ATC115	5163-271-008	282
80	ATC115	5163-271-009	282
80	ATC115	5163-271-010	282
80	ATC115	5163-271-011	282
80	ATC115	5163-271-012	282
80	ATC115	5163-271-013	282
67	EC375	5180-271-002	270
67	EC375	5180-271-004	270
67	EC375	5180-271-005	270
67	EC375	5180-271-006	270
67	EC375	5180-271-008	270
67	EC375	5180-271-009	270
67	EC475	5181-271-031	270
67	EC475	5181-271-032	270
67	EC475	5181-271-033	270
67	EC475	5181-271-034	270
67	EC475	5181-271-035	270
67	EC475	5181-271-036	270
67	EC475	5181-271-037	270
67	EC475	5181-271-038	270
67	EC475	5181-271-039	270
80	ATB25	5191-170-002	284
80	ATB25	5191-170-003	284

Page	Model Number	Part Number	Service Parts Page
80	ATB25	5191-170-004	284
80	ATB25	5191-170-005	284
80	ATB25	5191-170-006	284
80	ATB25	5191-170-007	284
80	ATB25	5191-170-008	284
80	ATB25	5191-170-009	284
80	ATB25	5191-170-010	284
80	ATB25	5191-170-011	284
80	ATB25	5191-170-012	284
80	ATB25	5191-170-013	284
80	ATB55	5192-170-002	284
80	ATB55	5192-170-003	284
80	ATB55	5192-170-004	284
80	ATB55	5192-170-005	284
80	ATB55	5192-170-006	284
80	ATB55	5192-170-007	284
80	ATB55	5192-170-008	284
80	ATB55	5192-170-009	284
80	ATB55	5192-170-010	284
80	ATB55	5192-170-011	284
80	ATB55	5192-170-012	284
80	ATB55	5192-170-013	284
80	ATB115	5193-170-002	284
80	ATB115	5193-170-003	284
80	ATB115	5193-170-004	284
80	ATB115	5193-170-005	284
80	ATB115	5193-170-006	284
80	ATB115	5193-170-007	284
80	ATB115	5193-170-008	284
80	ATB115	5193-170-009	284
80	ATB115	5193-170-010	284
80	ATB115	5193-170-011	284
80	ATB115	5193-170-012	284
80	ATB115	5193-170-013	284
94	EP500	5230-273-002	288
94	EP500	5230-273-003	288
94	EP500	5230-273-011	288
94	EP825	5231-273-002	289
94	EP825	5231-273-003	289
94	EP825	5231-273-004	289
94	EP1000	5232-273-002	290
94	EP1000	5232-273-003	290
94	EP1000	5232-273-005	290
94	EP1525	5234-273-002	292
94	EP1525	5234-273-003	292
94	EP1525 HT	5234-273-012	292
94	EP1525 HT	5234-273-017	292
138	ER825	5250-25	297
138	ER825	5250-30	297
138	ER1225	5252-4	297
138	ER1225	5252-9	297
138	ER375	5254-1	296
138	ER475	5255-5	296
138	ER475	5255-6	296
138	ER650	5256-6	296
138	ER650	5256-7	296
67	EC650	5281-271-002	270
67	EC650	5281-271-003	270
67	EC650	5281-271-004	270
67	EC650	5281-271-005	270
67	EC650	5281-271-006	270
67	EC650	5281-271-007	270
67	EC650	5281-271-008	270
67	EC650	5281-271-009	270
67	EC650	5281-271-016	270
67	EC650	5281-271-018	270

Page	Model Number	Part Number	Service Parts Page
67	EC650	5281-271-019	270
67	EC650	5281-271-020	270
67	EC825	5282-271-002	272
67	EC825	5282-271-003	272
67	EC825	5282-271-004	272
67	EC825	5282-271-008	272
67	EC825	5282-271-009	272
67	EC825	5282-271-010	272
67	EC825	5282-271-011	272
67	EC825	5282-271-012	272
67	EC825	5282-271-013	272
67	EC1000	5283-271-002	274
67	EC1000	5283-271-003	274
67	EC1000	5283-271-004	274
67	EC1000	5283-271-005	274
67	EC1000	5283-271-010	274
67	EC1000	5283-271-011	274
67	EC1000	5283-271-012	274
67	EC1000	5283-271-013	274
67	EC1225	5284-271-002	274
67	EC1225	5284-271-003	274
67	EC1225	5284-271-004	274
67	EC1225	5284-271-005	274
67	EC1225	5284-271-008	274
67	EC1225	5284-271-010	274
67	EC1225	5284-271-013	274
67	EC1225	5284-271-014	274
67	EC1225	5284-271-015	274
	UM-50-1020/CBC-150	5370-9	232
	UM100-1020/CBC150	5370-10	235
55	EUM50-1020	5370-15	233
55	EUM50-1020	5370-16	233
	EM100-20MBFB	5370-169-007	NA
	EM100-20FBB	5370-169-020	NA
	EM100-20	5370-169-040	252
	EM100-20	5370-169-041	252
	EM50-20	5370-169-042	252
	EM50-20	5370-169-043	252
	EM50-20	5370-169-045	252
	EM50-20MB	5370-169-047	256
	EM50-20MB	5370-169-048	256
	EM180-20	5370-169-050	252
	EM180-20	5370-169-051	252
	EM180-20MB	5370-169-053	256
	EM180-20MB	5370-169-054	256
	EM50-20FBC	5370-169-056	NA
	EM180-20FBC	5370-169-057	NA
	EM50-20FBB	5370-169-058	NA
	EM180-20FBB	5370-169-059	NA
	EM50-20MBFB	5370-169-060	NA
	EM180-20MBFB	5370-169-061	NA
	EM50-20MB	5370-169-062	256
	EM50-20MBFB	5370-169-063	NA
	EM50-20FBC	5370-169-065	NA
	EM50-20FBB	5370-169-066	NA
	EM180-20FBC	5370-169-067	NA
	EM180-20FBB	5370-169-068	NA
	EM180-20MBFB	5370-169-069	NA
	EM180-20	5370-169-070	252
	EM100-20	5370-169-072	252
	EM180-20MB	5370-169-073	NA
	EM100-20FBB	5370-169-084	NA
	EM100-20MBFB	5370-169-085	NA
	EM100-20FBC	5370-169-108	NA
	EM100-20FBC	5370-169-109	NA
31	EM50-20	5370-169-201	250

Index

Page	Model Number	Part Number	Service Parts Page
24	EM50-20	5370-169-203	250
24	EM50-20	5370-169-204	250
24	EM100-20	5370-169-206	250
24	EM100-20	5370-169-208	250
24	EM100-20	5370-169-209	250
24	EM180-20	5370-169-211	250
24	EM180-20	5370-169-213	250
24	EM180-20	5370-169-214	250
24	EM50-20MB	5370-169-216	254
24	EM50-20MB	5370-169-218	254
24	EM50-20MB	5370-169-219	254
24	EM180-20MB	5370-169-221	254
24	EM180-20MB	5370-169-223	254
24	EM180-20MB	5370-169-224	254
160	EM50-20FBC	5370-169-233	NA
160	EM50-20FBC	5370-169-234	NA
160	EM100-20FBC	5370-169-238	NA
160	EM100-20FBC	5370-169-239	NA
160	EM180-20FBC	5370-169-243	NA
160	EM180-20FBC	5370-169-244	NA
160	EM50-20MBFB	5370-169-248	NA
160	EM50-20MBFB	5370-169-249	NA
160	EM100-20MBFB	5370-169-253	NA
160	EM100-20MBFB	5370-169-254	NA
160	EM180-20MBFB	5370-169-258	NA
160	EM180-20MBFB	5370-169-259	NA
160	EUM50-20FBB-6	5370-169-260	NA
160	EUM100-20FBB-12	5370-169-261	NA
160	EUM180-20FBB-12	5370-169-262	NA
160	EUM50-20MBFB-6	5370-169-263	NA
160	EUM100-20MBFB-12	5370-169-264	NA
160	EUM180-20MBFB-12	5370-169-265	NA
160	EM50-20FBB	5370-169-278	NA
160	EM50-20FBB	5370-169-279	NA
160	EM100-20FBB	5370-169-283	NA
160	EM100-20FBB	5370-169-284	NA
160	EM180-20FBB	5370-169-288	NA
160	EM180-20FBB	5370-169-289	NA
	EUM50-20MBFB-6	5370-169-965	NA
	EUM50-20MBFB-10	5370-169-968	NA
	EUM100-20MBFB-12	5370-169-971	NA
	EUM100-20MBFB-21	5370-169-980	NA
	EUM50-20FBB-6	5370-169-983	NA
	EUM50-20FBB-10	5370-169-986	NA
	EUM100-20FBB-12	5370-169-989	NA
	EUM100-20FBB-21	5370-169-992	NA
	EUM180-20FBB-12	5370-169-995	NA
	EUM180-20FBB-21	5370-169-998	NA
56	EUM50-1020	5370-17	233
117,120	EM50/ERS42	5370-170-201	NA
117,120	EM50/ERS42	5370-170-203	NA
117,120	EM50/ERS49	5370-170-206	NA
117,120	EM50/ERS49	5370-170-207	NA
117,120	EM180/ERS57	5370-170-211	NA
117,120	EM180/ERS57	5370-170-212	NA
117,120	EM210/ERS68	5371-170-042	NA
117,120	EM210/ERS68	5371-170-043	NA
56	EUM100-1020	5370-18	233
56	EUM100-1020	5370-19	233
56	EUM100-1020	5370-20	233
56	EUM180-1020	5370-21	233
56	EUM180-1020	5370-22	233
56	EUM180-1020	5370-23	233
21	EUM50-1040	5370-24	236
21	EUM180-1040	5370-25	236

Page	Model Number	Part Number	Service Parts Page
22	EUM50-2030	5370-26	240
22	EUM50-2030	5370-27	240
NA	EM50-10	5370-270-015	249
NA	EM50-30	5370-270-016	259
NA	EM180-10	5370-270-017	249
NA	EM50-30	5370-270-019	259
NA	EM50-10	5370-270-020	249
NA	EM180-10	5370-270-021	249
NA	EM50-10	5370-270-030	249
NA	EM100-10	5370-270-045	249
NA	EM100-10	5370-270-046	249
NA	EM100-30	5370-270-047	259
NA	EM100-30	5370-270-048	259
NA	EM180-30	5370-270-049	259
NA	EM180-30	5370-270-050	259
NA	EM50-30	5370-270-052	259
NA	EM180-30	5370-270-053	259
NA	EM100-30	5370-270-054	259
NA	EM180-30	5370-270-055	259
NA	EM100-30	5370-270-056	259
24	EM50-10	5370-270-201	248
24	EM50-10	5370-270-203	248
24	EM50-10	5370-270-204	248
24	EM100-10	5370-270-206	248
24	EM100-10	5370-270-208	248
24	EM100-10	5370-270-209	248
24	EM180-10	5370-270-211	248
24	EM180-10	5370-270-213	248
24	EM180-10	5370-270-214	248
24	EM50-30	5370-270-216	258
24	EM50-30	5370-270-218	258
24	EM50-30	5370-270-219	258
24	EM100-30	5370-270-221	258
24	EM100-30	5370-270-223	258
24	EM100-30	5370-270-224	258
24	EM180-30	5370-270-226	258
24	EM180-30	5370-270-228	258
24	EM180-30	5370-270-229	258
NA	UM50-1040	5370-271-004	238
NA	UM50-1040	5370-271-005	238
NA	UM50-1040	5370-271-006	238
NA	UM50-3040	5370-271-009	246
NA	UM50-3040	5370-271-010	246
NA	UM50-3040	5370-271-011	246
NA	UM180-1040	5370-271-014	238
NA	UM180-1040	5370-271-015	238
NA	UM180-1040	5370-271-016	238
NA	UM180-3040	5370-271-019	246
NA	UM180-3040	5370-271-020	246
NA	UM180-3040	5370-271-021	246
NA	UM100-1040	5370-271-024	238
NA	UM100-1040	5370-271-025	238
NA	UM100-1040	5370-271-026	238
	UM100-3040	5370-271-029	246
	UM100-3040	5370-271-030	246
	UM100-3040	5370-271-031	246
	EUM50-1040	5370-271-050	264
	EUM180-1040	5370-271-051	264
15	UM50-1040	5370-271-201	236
15	UM50-1040	5370-271-203	236
15	UM50-1040	5370-271-204	236
15	UM100-1040	5370-271-206	236
15	UM100-1040	5370-271-208	236
15	UM100-1040	5370-271-209	236

Page	Model Number	Part Number	Service Parts Page
15	UM180-1040	5370-271-211	236
15	UM180-1040	5370-271-213	236
15	UM180-1040	5370-271-214	236
15	UM50-3040	5370-271-216	244
15	UM50-3040	5370-271-218	244
15	UM50-3040	5370-271-219	244
15	UM100-3040	5370-271-221	244
15	UM100-3040	5370-271-223	244
15	UM100-3040	5370-271-224	244
15	UM180-3040	5370-271-226	244
15	UM180-3040	5370-271-228	244
15	UM180-3040	5370-271-229	244
NA	UM180-1020	5370-273-006	235
NA	UM180-1020	5370-273-007	235
NA	UM180-1020	5370-273-008	235
NA	UM180-2030	5370-273-011	242
NA	UM180-2030	5370-273-012	242
NA	UM180-2030	5370-273-013	242
NA	UM50-1020	5370-273-016	235
NA	UM50-1020	5370-273-017	235
NA	UM50-1020	5370-273-018	235
NA	UM50-2030	5370-273-021	242
NA	UM50-2030	5370-273-022	242
NA	UM50-2030	5370-273-023	242
NA	UM100-1020	5370-273-026	235
NA	UM100-1020	5370-273-027	235
NA	UM100-1020	5370-273-028	235
NA	UM100-2030	5370-273-031	242
NA	UM100-2030	5370-273-032	242
NA	UM100-2030	5370-273-033	242
NA	UM50-1020FBC	5370-273-036	NA
NA	UM50-1020FBC	5370-273-037	NA
NA	UM50-2030FBC	5370-273-041	NA
NA	UM50-2030FBC	5370-273-042	NA
NA	UM180-1020FBC	5370-273-046	NA
NA	UM180-1020FBC	5370-273-047	NA
NA	UM180-2030FBC	5370-273-051	NA
NA	UM180-2030FBC	5370-273-052	NA
	EUM50-1020	5370-273-057	235
	EUM50-1020	5370-273-058	235
	EUM50-1020	5370-273-059	263
NA	EUM50-2030	5370-273-061	266
NA	EUM50-2030	5370-273-062	266
NA	EUM50-2030	5370-273-063	266
NA	EUM180-1020	5370-273-065	263
NA	EUM180-1020	5370-273-066	263
NA	EUM180-1020	5370-273-067	263
NA	EUM180-2030	5370-273-069	266
NA	EUM180-2030	5370-273-070	266
NA	EUM180-2030	5370-273-071	266
NA	UM180-1020C	5370-273-073	TS
NA	UM180-1020C	5370-273-074	TS
NA	UM180-1020C	5370-273-075	TS
NA	UM50-1020C	5370-273-077	TS
NA	UM50-1020C	5370-273-078	TS
NA	UM50-1020C	5370-273-079	TS
NA	UM180-2030C	5370-273-081	TS
NA	UM180-2030C	5370-273-082	TS
NA	UM180-2030C	5370-273-083	TS
NA	UM50-2030C	5370-273-085	TS
NA	UM50-2030C	5370-273-086	TS
NA	UM50-2030C	5370-273-087	TS
NA	EUM100-1020	5370-273-091	263
NA	EUM100-1020	5370-273-092	263
NA	EUM100-1020	5370-273-093	263

Page	Model Number	Part Number	Service Parts Page
NA	EUM50-1020W	5370-273-099	263
NA	EUM50-1020W	5370-273-100	263
NA	EUM50-1020W	5370-273-101	263
NA	EUM50-2030W	5370-273-103	266
NA	EUM50-2030W	5370-273-104	266
NA	EUM50-2030W	5370-273-105	266
NA	EUM100-1020W	5370-273-107	263
NA	EUM100-1020W	5370-273-108	263
NA	EUM100-1020W	5370-273-109	263
NA	EUM180-1020W	5370-273-115	263
NA	EUM180-1020W	5370-273-116	263
NA	EUM180-1020W	5370-273-117	263
NA	EUM180-2030W	5370-273-119	266
NA	EUM180-2030W	5370-273-120	266
NA	EUM180-2030W	5370-273-121	266
NA	UM180-1020/CBC150	5370-273-122	
NA	UM100-1020FBC	5370-273-125	NA
NA	UM100-1020FBC	5370-273-153	NA
NA	UM100-2030FBC	5370-273-154	NA
NA	UM100-2030FBC	5370-273-155	NA
15	UM50-1020	5370-273-201	233
15	UM50-1020	5370-273-203	233
15	UM50-1020	5370-273-204	233
15	UM100-1020	5370-273-206	233
15	UM100-1020	5370-273-208	233
15	UM100-1020	5370-273-209	233
15	UM180-1020	5370-273-211	233
15	UM180-1020	5370-273-213	233
15	UM180-1020	5370-273-214	233
15	UM50-2030	5370-273-216	240
15	UM50-2030	5370-273-218	240
15	UM50-2030	5370-273-219	240
15	UM100-2030	5370-273-221	240
15	UM100-2030	5370-273-223	240
15	UM100-2030	5370-273-224	240
15	UM180-2030	5370-273-226	240
15	UM180-2030	5370-273-228	240
15	UM180-2030	5370-273-229	240
18	UM50-1020/CBC150	5370-273-230	233
18	UM100-1020/CBC150	5370-273-231	233
18	UM180-1020/CBC150	5370-273-232	233
40	UM50-1020LK	5370-273-236	268
40	UM100-1020LK	5370-273-237	268
40	UM180-1020LK	5370-273-238	268
48	UM50-1020FBC	5370-273-243	NA
48	UM50-1020FBC	5370-273-244	NA
48	UM100-1020FBC	5370-273-248	NA
48	UM100-1020FBC	5370-273-249	NA
48	UM180-1020FBC	5370-273-253	NA
48	UM180-1020FBC	5370-273-254	NA
48	UM50-2030FBC	5370-273-258	NA
48	UM50-2030FBC	5370-273-259	NA
48	UM100-2030FBC	5370-273-263	NA
48	UM100-2030FBC	5370-273-264	NA
48	UM180-2030FBC	5370-273-268	NA
48	UM180-2030FBC	5370-273-269	NA
42	UM50-1020C	5370-273-271	TS
42	UM50-1020C	5370-273-273	TS
42	UM50-1020C	5370-273-274	TS
42	UM180-1020C	5370-273-276	TS
42	UM180-1020C	5370-273-278	TS
42	UM180-1020C	5370-273-279	TS

Index

Page	Model Number	Part Number	Service Parts Page
42	UM50-2030C	5370-273-281	TS
42	UM50-2030C	5370-273-283	TS
42	UM50-2030C	5370-273-284	TS
42	UM180-2030C	5370-273-286	TS
42	UM180-2030C	5370-273-288	TS
42	UM180-2030C	5370-273-289	TS
20	UM180-1020	5370-273-323	233
20	UM180-1020	5370-273-324	233
22,50	EUM50-2030	5370-28	240
22,50	EUM180-2030	5370-29	240
22,50	EUM180-2030	5370-30	240
22,50	EUM180-2030	5370-31	240
156	EUM50-20FBB-10	5370-32	NA
156	EUM100-20FBB-21	5370-33	NA
156	EUM180-20FBB-21	5370-34	NA
156	EUM50-20MBFB-10	5370-35	NA
156	EUM100-20MBFB-21	5370-36	NA
156	EUM180-20MBFB-21	5370-37	NA
	EM100-40	5370-536-007	261
	EM50-40	5370-536-008	261
	EM180-40	5370-536-009	261
24	EM50-40	5370-536-200	260
24	EM100-40	5370-536-201	260
24	EM180-40	5370-536-202	260
	UM50-1020/CBC150	5370-9	235
24	EM210-20	5371-169-022	252
24	EM210-20	5371-169-023	252
24	EM210-20MB	5371-169-025	256
24	EM210-20MB	5371-169-026	256
160	EM210-20FBC	5371-169-028	NA
160	EM210-20FBB	5371-169-029	NA
160	EM210-20FBC	5371-169-031	NA
160	EM210-20FBB	5371-169-032	NA
160	EM210-20MBFB	5371-169-033	NA
29	EM210-20	5371-169-034	252
152	EM210-20FBB	5371-169-035	NA
160	EM215-20FBB	5371-169-054	NA
156	EUM210-20MBFB-32	5371-169-056	NA
156	EUM210-20MBFB-56	5371-169-060	NA
156	EUM210-7/8MBFB-32	5371-169-064	NA
156	EUM210-7/8MBFB-56	5371-169-068	NA
156	EUM210-7/8MBFB	5371-169-072	NA
31	EM215-20	5371-169-076	252
152	EUM210-20FBB-32	5371-169-078	NA
152	EUM210-20FBB-56	5371-169-082	NA
152	EUM215-20FBB-32	5371-169-086	NA
152	EUM215-20FBB-56	5371-169-090	NA
159	EM215-20FBB	5371-169-100	NA
159	EM210-7/8 20MBFB	5371-169-101	NA
117,120	EM210/ERS68	5371-170-042	NA
117,120	EM210/ERS68	5371-170-043	NA
159	EM210-20MBFB	5371-269-030	NA
24	EM210-10	5371-270-009	249
24	EM210-10	5371-270-011	249
24	EM210-30	5371-270-023	259
24	EM210-30	5371-270-024	259
24	EM210-30	5371-270-026	259
24	EM210-10	5371-270-027	249
14	UM210-1040	5371-271-002	238
14	UM210-1040	5371-271-003	238
14	UM210-1040	5371-271-004	238
14	UM210-3040	5371-271-007	246
14	UM210-3040	5371-271-008	246
14	UM210-3040	5371-271-009	246

Page	Model Number	Part Number	Service Parts Page
14	UM215-3040	5371-271-021	246
14	UM215-3040	5371-271-022	246
14	UM215-3040	5371-271-023	246
14	UM210-1020	5371-273-002	235
14	UM210-1020	5371-273-003	235
14	UM210-1020	5371-273-004	235
14	UM210-2030	5371-273-007	242
14	UM210-2030	5371-273-008	242
14	UM210-2030	5371-273-009	242
145	UM210-1020FBC	5371-273-012	NA
145	UM210-1020FBC	5371-273-013	NA
145	UM210-2030FBC	5371-273-017	NA
145	UM210-2030FBC	5371-273-018	NA
51	EUM210-1040	5371-273-024	264
14	UM215-1040	5371-273-026	238
14	UM215-1040	5371-273-027	238
51	EUM210-1020	5371-273-027	262
14	UM215-1040	5371-273-028	238
51	EUM210-1020	5371-273-028	262
51	EUM210-1020	5371-273-029	262
51	EUM210-2030	5371-273-031	266
51	EUM210-2030	5371-273-032	266
51	EUM210-2030	5371-273-033	266
42	UM210-1020C	5371-273-035	TS
42	UM210-1020C	5371-273-036	TS
42	UM210-1020C	5371-273-037	TS
42	UM210-2030C	5371-273-039	TS
42	UM210-2030C	5371-273-040	TS
42	UM210-2030C	5371-273-041	TS
14	UM215-2030	5371-273-043	242
14	UM215-2030	5371-273-044	242
14	UM215-2030	5371-273-045	242
60	EUM210-1020W	5371-273-055	262
60	EUM210-1020W	5371-273-056	262
60	EUM210-1020W	5371-273-057	262
60	EUM210-2030W	5371-273-059	266
60	EUM210-2030W	5371-273-060	266
60	EUM210-2030W	5371-273-061	266
14	UM215-1020	5371-273-076	262
14	UM215-1020	5371-273-077	262
14	UM215-1020	5371-273-078	262
152	UM215-1020FBC	5371-273-079	NA
51	EUM215-1020	5371-273-082	262
51	EUM215-1020	5371-273-083	262
51	EUM215-1020	5371-273-084	262
69	EUM215-1020W	5371-273-086	262
69	EUM215-1020W	5371-273-087	262
69	EUM215-1020W	5371-273-088	262
18	UM215-1020/CBC150	5371-273-090	234
152	UM215-2030FBC	5371-273-100	NA
152	UM215-2030FBC	5371-273-101	NA
18	UM210-1020/CBC150	5371-4	234
24	EM210-40	5371-536-005	261
74	EB375	5380-170-002	276
74	EB375	5380-170-003	276
74	EB375	5380-170-004	276
74	EB375	5380-170-005	276
74	EB375	5380-170-006	276
74	EB375	5380-170-007	276
74	EB475	5381-170-002	276
74	EB475	5381-170-003	276
74	EB475	5381-170-004	276

Page	Model Number	Part Number	Service Parts Page
74	EB650	5382-170-002	276
74	EB650	5382-170-003	276
74	EB650	5382-170-005	276
74	EB825	5383-170-002	278
74	EB825	5383-170-004	278
74	EB825	5383-170-005	278
74	EB1000	5384-170-002	280
74	EB1000	5384-170-003	280
74	EB1000	5384-170-005	280
74	EB1225	5385-170-002	280
74	EB1225	5385-170-003	280
74	EB1225	5385-170-005	280
134	FB375	5390-170-021	294
134	FB375	5390-170-022	294
134	FB375	5390-170-023	294
134	FB375	5390-170-024	294
134	FB475	5391-170-009	294
134	FB475	5391-170-012	294
134	FB650	5392-170-007	294
134	FB650	5392-170-010	294
94	EP170	5633-273-002	286
94	EP170	5633-273-003	286
94	EP170	5633-273-005	286
100	EP 170C	5633-273-018	NA
100	EP 170C	5633-273-019	NA

OBSOLETE

Notes

OBSOLETE

OBSOLETE

Notes

OBSOLETE

OBSOLETE

Notes

OBSOLETE

Other

Warner Electric Clutch/Brake Products

Warner Electric engineers, manufactures and markets, a wide array of electromechanical components and systems for controlling motion. Designed to help increase productivity, our products are incorporated into new equipment designs and are also used to upgrade performance on machines already in service. With an international organization of stocking distributors and sales centers, Warner Electric offers the most extensive network of its kind for locally available products and professional, on-the-spot customer service.

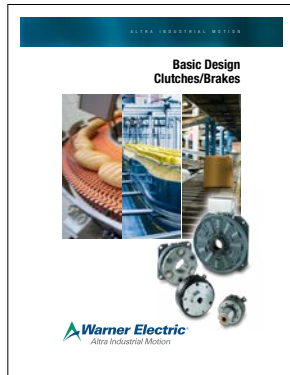

Basic Design Clutches and Brakes
Catalog P-1264-WE

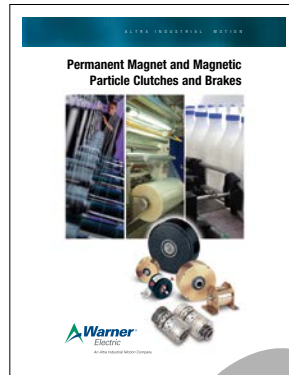

Permanent Magnet and Magnetic Particle Clutches and Brakes
Catalog P-1316-WE



Wrap Spring Clutches and Clutch/Brakes
Catalog P-1310-WE

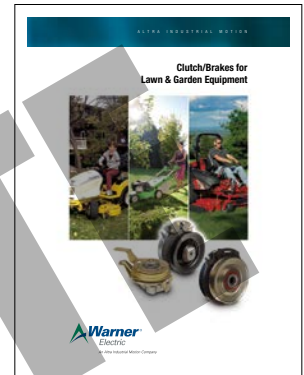

Lawn & Garden Clutch/Brakes
Catalog P-1698-WE



Magnetic Capping Headsets and Chucks
Brochure P-1638-WE



Forklift Truck Brakes
Brochure P-7637-C

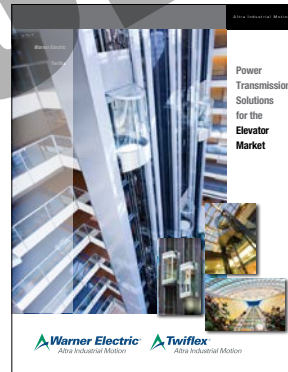

Electrically Released Brakes for Elevators
Brochure P-1733-C



Custom Electromagnetic Coils
Brochure P-1298-WE

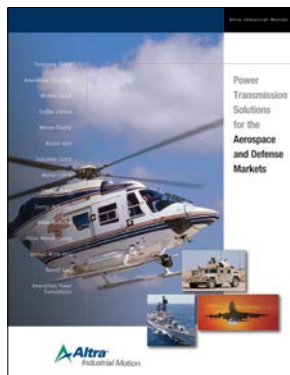

Solutions for the Aerospace and Defense Markets
Brochure P-1717-C



Application Profiles and Magazine Articles
Visit www.warnerelectric.com



Warner Electric Facilities

North America

31 Industrial Park Road
New Hartford, CT 06057 - USA
860-379-1252

*Electromagnetic Clutches
and Brakes*

449 Gardner Street
South Beloit, IL 61080 - USA
815-389-3771

4578 East Park 30 Drive
Columbia City, IN 46725 - USA
260-244-6183

*Precision Electric Coils and
Electromagnetic Clutches and
Brakes*

Customer Service
1-800-825-6544

For Application Support
1-800-825-9050

Europe

7, rue Champfleu, B.P. 20095
St Barthelemy d'Anjou - France
+33 (0)2 41 21 24 24

*Electromagnetic Clutches
and Brakes*

Customer Service
+33 (0)2 41 21 24 76

For Application Support
+33 (0) 2 41 21 24 24

Asia Pacific

Australia
+61 2 9894 0133

China
+86 21 5169-9255

Hong Kong
+852 2615 9313

Singapore
+65 6487 4464

Taiwan
+886 2 2577 8156

Thailand
+66 2322 5527

The Brands of Altra Industrial Motion

Couplings

Ameridrives
www.ameridrives.com

Bibby Turboflex
www.bibbyturboflex.com

Guardian Couplings
www.guardiancouplings.com

Huco
www.huco.com

Lamiflex Couplings
www.lamiflexcouplings.com

Stromag
www.stromag.com

TB Wood's
www.tbwoods.com

Geared Cam Limit Switches

Stromag
www.stromag.com

Electric Clutches & Brakes

Inertia Dynamics
www.idicb.com

Matrix
www.matrix-international.com

Stromag
www.stromag.com

Warner Electric
www.warnerelectric.com

Linear Products

Warner Linear
www.warnerlinear.com

Engineered Bearing Assemblies

Kilian
www.kilianbearings.com

Heavy Duty Clutches & Brakes

Industrial Clutch
www.indclutch.com

Twiflex
www.twiflex.com

Stromag
www.stromag.com

Svendborg Brakes
www.svendborg-brakes.com

Wichita Clutch
www.wichitaclutch.com

Belted Drives

TB Wood's
www.tbwoods.com

Gearing

Bauer Gear Motor
www.bauergears.com

Boston Gear
www.bostongear.com

Delroyd Worm Gear
www.delroyd.com

Nuttall Gear
www.nuttallgear.com

Overrunning Clutches

Formsprag Clutch
www.formsprag.com

Marland Clutch
www.marland.com

Stieber Clutch
www.stieberclutch.com

Neither the accuracy nor completeness of the information contained in this publication is guaranteed by the company and may be subject to change in its sole discretion. The operating and performance characteristics of these products may vary depending on the application, installation, operating conditions and environmental factors. The company's terms and conditions of sale can be viewed at <http://www.altramotion.com/terms-and-conditions/sales-terms-and-conditions>. These terms and conditions apply to any person who may buy, acquire or use a product referred to herein, including any person who buys from a licensed distributor of these branded products.

©2017 by Warner Electric LLC. All rights reserved. All trademarks in this publication are the sole and exclusive property of Warner Electric LLC or one of its affiliated companies.