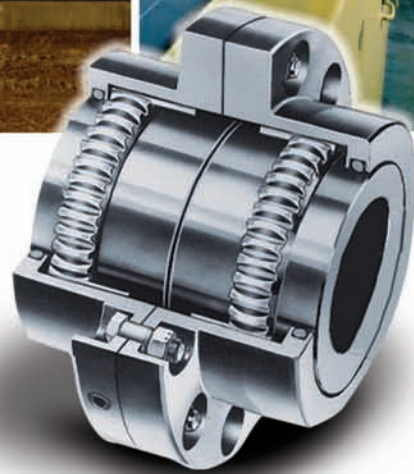
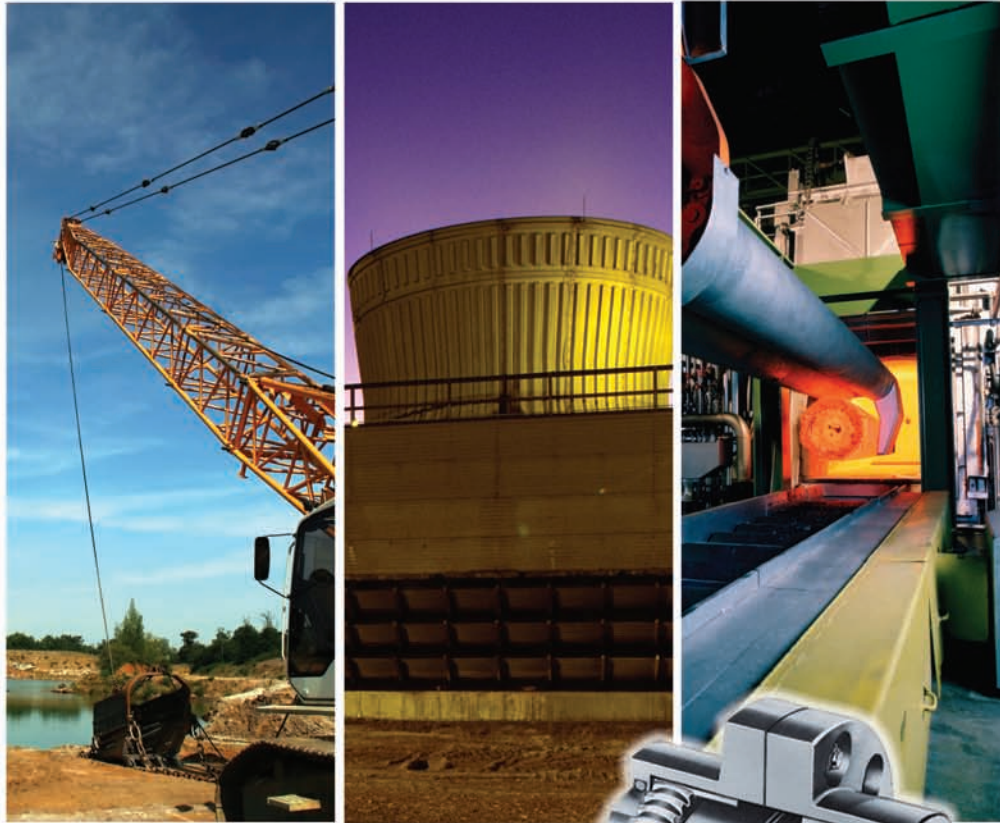


Amerigear® Standard Gear Couplings Flanged and Continuous Sleeve Designs



 **Ameridrives®**
Couplings

An Altra Industrial Motion Company

Amerigear

Flexible Couplings

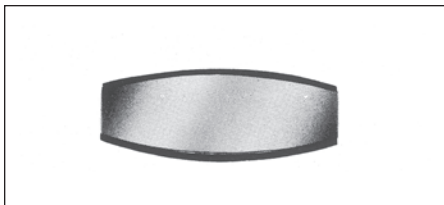
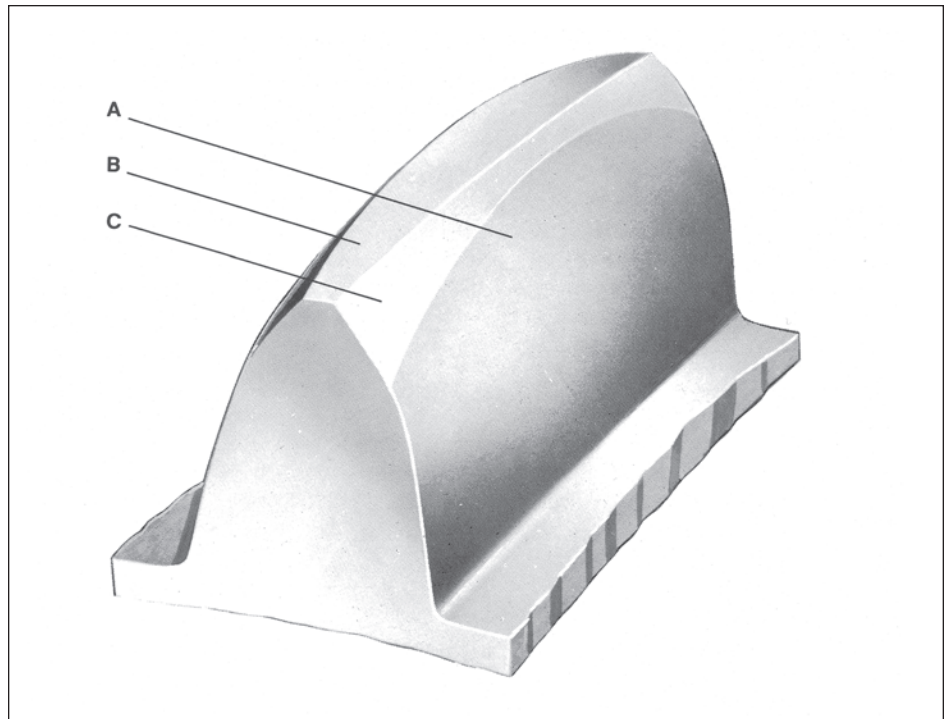
Fully-Crowned Teeth

The Basis For Gear Tooth Design

Amerigear . . . the first, the finest . . . flexible coupling with Fully-Crowned Gear Teeth.

In contrast with ordinary gear tooth forms, the Amerigear Fully-Crowned Tooth represents the ultimate achievement in the art of gear tooth design, wherein all three working portions of the tooth are crowned. As a result, the teeth act much like a rocking chair, capable of sliding freely in the axial direction without digging or gouging the internal mating teeth. Because of this design advantage, Amerigear Flexible Couplings with Fully-Crowned Gear Teeth offer operational benefits of maximum load-carrying capacity with minimum size, maximum reliability and long life.

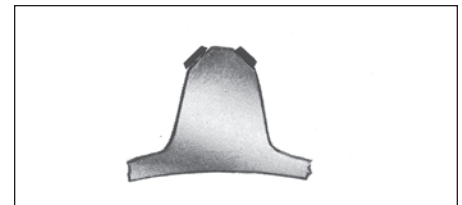
Amerigear . . . often copied, but never equaled.



Crowned Flanks Flanks of the teeth are crowned so that tooth thickness is greatest at the center of the tooth. This assures larger contact area per tooth for higher torque requirements and puts more teeth in contact for a given angle. Actual tooth loading takes place near the center of the tooth face where tooth thickness is greatest. Crowned flanks also eliminate end-of-tooth loading, provide optimum load distribution, and accommodate all types of misalignment with minimum backlash, while transmitting constant velocity. This design provides good oil film characteristics for efficient lubrication.



Crowned Tips Tips of teeth are crowned with a radius equal to the outside of the gear element. The crowned tip contacts the root of internal gear teeth in the external sleeve, accurately piloting the sleeve with true concentric ball-and-socket action. This permits minimum diametral sleeve clearance and centers the sleeve physically to assure good dynamic balance characteristics under various loading and misalignment conditions.



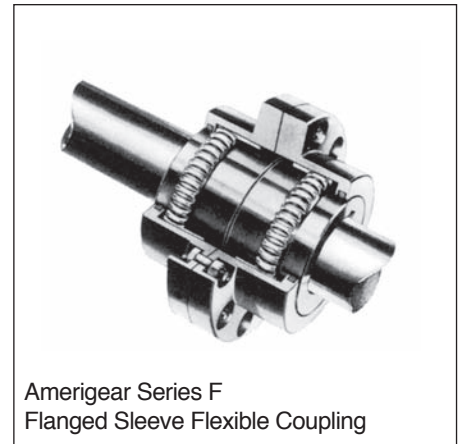
Crowned Chamfers Faces of the teeth adjacent to the tips are chamfered to eliminate interference with the sleeve tooth fillets. This allows the true involute flanks of the gear teeth to be in contact with the sleeve teeth and assures freedom to misalign.

In accordance with our established policy to constantly improve our products, the specifications contained herein are subject to change without notice.

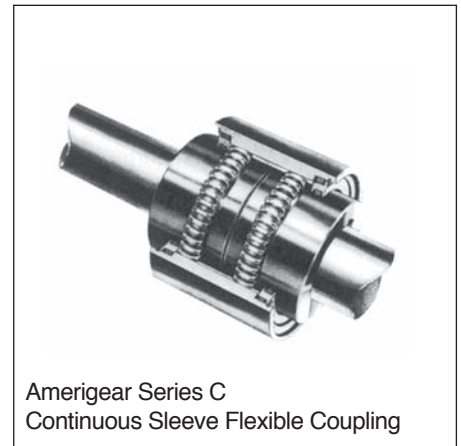


Table of Contents

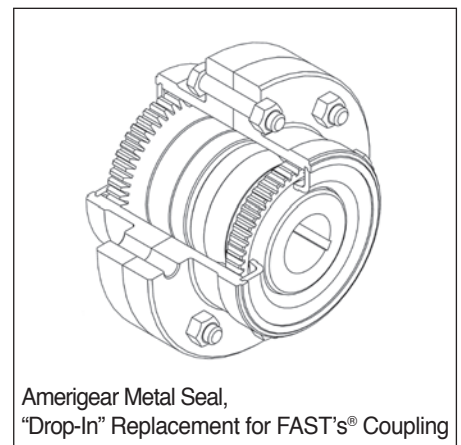
	Page
Amerigear Design Advantages	4-5
Amerigear Ordering Information	6-7
Amerigear Flanged Sleeve Series F Couplings	
Series F, FS - Standard	8-11
Series FM, FMS - Mill Motor (Taper Shaft)	12-13
Series FA, FAS - Axial Travel	14-18
Series FE - Extended (Spacer)	19
Series FV, FVS - Vertical	20-21
Series FPH, FSPH - Shear Pin	22
Amerigear Modifications and Variations – Series F	
Reverse Mounted Hubs	23
Tandems, FSM - Mill Motor Rigid, Universal Hubs	24
Limited End Float, FD & FDC Disconnect Couplings	25
FB - Brake Drum, FI - Insulated, Adjustable Axial Position (Jordan) Couplings	26
FR - Rigid & Differential Tooth Couplings, Adaptors	27
FL - Continuous Lubricated & Double Flex Couplings	28
Amerigear Continuous Sleeve Series C Couplings	
Series C, CS - Standard	29-30
Amerigear Modifications and Variations – Series C	
CB - Brake Drum, Limited End Float, CL - Continuous Lubricated Couplings	31
Blind Assembly, CM & CMS Mill Motor Couplings	32
CA & CAS - Axial Travel, CV & CVS - Vertical Shaft Couplings	33
Amerigear Engineering Data	
Speeds, Classes and Balance	34-35
Maximum Speeds - Series FE and FEL	36
Maximum Speeds - Series ES Tandems	37
Weights, WR ² , Torsional Stiffness and Engineering Calculations.....	38-39
Maximum Bore, Keyway and Puller Hole Data	40
Dimensional Data Flange Details Series F.....	41
Additional Dimensional Data - F and C	42-43
Alignment, Installation, Lubrication and Maintenance Instructions.....	44-46
Amerigear Metal Seal	
Flexible Couplings	47
Full-Flex Couplings - Series F Size 1 1/2 - 7	48
Flex-Rigid Couplings - Series FS Size 1 1/2 - 7	49
Modifications & Variations	50
American Jaw Flange Coupling	51
IDENTIFICATION OF COUPLING TYPES	
F	Flanged Sleeve
C	Continuous Sleeve
FS and CS	Single Engagement
FM and CM	Mill Motor (Taper Shaft)
FMS and CMS	Mill Motor Single Engagement
FV and CV	Vertical
FVS and CVS	Vertical Single Engagement
FA and CA	Axial Travel
FAS and CAS	Axial Travel Single Engagement
FE	Extended (Spacer)
FL and CL	Continuously Lubricated
FEL	Extended, Continuously Lubricated
FR	Rigid
FD and FDC	Disconnect (Cut-out)
FB and CB	Brake Drum
FI	Insulated
FPH	Shear Pin
FSPH	Shear Pin Single Engagement



Amerigear Series F
Flanged Sleeve Flexible Coupling



Amerigear Series C
Continuous Sleeve Flexible Coupling



Amerigear Metal Seal,
"Drop-In" Replacement for FAST's® Coupling

Amerigear

Flexible Couplings

Design Advantages

The Flexible Coupling method of connecting rotating shafts is a vital and necessary technique. Large massive shafting, loosely mounted in sleeve bearings and merely joined together by rigidly bolted flanges, cannot provide efficient mechanical power transmission. Especially today, as machine designers and builders demand higher speeds, higher torques, and higher misalignment capacities, the need for "flexibly connecting" this equipment becomes apparent.

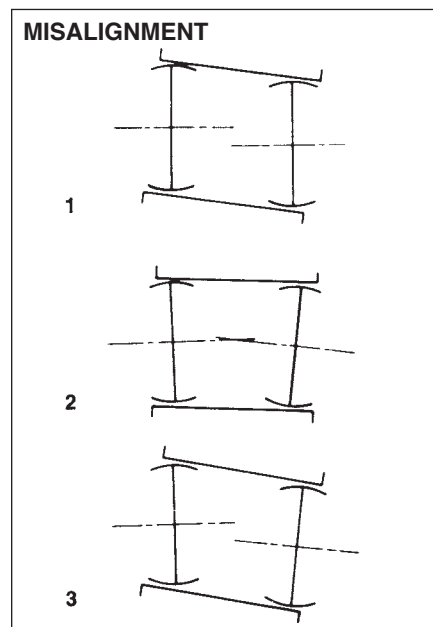
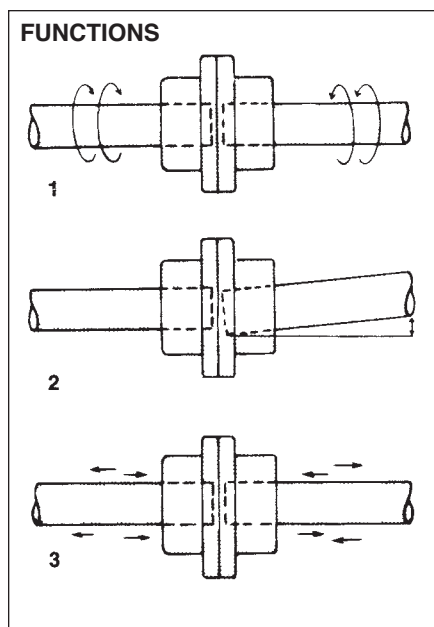
A flexible coupling is necessary since it is practically impossible to achieve and maintain perfect alignment of coupled rotating shafts. During initial assembly and installation, precise alignment of the shaft axes is not only difficult to achieve but in many cases it is economically unfeasible. During operation, alignment is even more difficult to maintain. Shaft misalignment – caused by uneven bearing wear, flexure of structural members, settling of foundations, thermal expansion, shaft deflection and other factors – is an operating certainty. Because these factors are extremely difficult to control, a flexible coupling serves as an ideal answer to compensate or minimize the effects of unavoidable misalignment and end movement of coupled shafts.

A flexible coupling must provide three basic functions:

1. Physically couple together two rotating shafts for efficient transmission of mechanical power, transferring the torque of one shaft to the other, directly and with constant velocity.
2. Compensate for all types of misalignment between rotating, connected shafts without inducing abnormal stresses and loads on connected equipment, and without tangible loss of power.
3. Compensate for end or axial movement of the coupled shafts, preventing either shaft from exerting excessive thrust on the other and allowing each to rotate in its normal position.

Three types of misalignment must be effectively accommodated by a flexible coupling.

1. Parallel Offset – axes of connected shafts are parallel, but not in the same straight line.
2. Angular – axes of shafts intersect at center point of coupling, but not in the same straight line.
3. Combined Angular-Offset – axes of shafts do not intersect at point of coupling and are not parallel.



Amerigear®

Amerigear Fully-Crowned Teeth (Fig. 1)

Crowned Flanks, Crowned Tips, Crowned Chamfers — recognized as the ultimate in gear tooth design and the secret of superior mechanical power transmission! Increased tooth contact area improves the load-carrying capacity of the teeth regardless of operating conditions and provides “ball-and-socket” piloting action at all misalignments. As a result, connected equipment is able to operate at higher torques, speeds, and misalignments with resultant longer life.

Rigid, strong, “floating” sleeve (Fig. 2)

A floating sleeve, containing internally-cut gear teeth at opposite ends, is made from medium carbon steel. In effect, it provides a “bridge” between driving and driven gear meshes. It can be furnished as a continuous, one-piece sleeve ... or made in two halves and bolted together.

Precision-machined identical hubs (Fig. 3)

Two identical hubs, machined to close tolerances, contain external Fully-Crowned Gear Teeth which totally engage internal teeth of the sleeve. Fully-Crowned Teeth enable coupling to operate longer, with minimum backlash while assuring free axial movement of connected shafts.

Positive dust-tight seals (Fig. 4)

Buna-N O-ring seals keep contamination out... vital lubricant in. They are designed to accommodate temperatures up to 250°F. For temperatures of 400°F continuous and 550°F for short periods, Viton O-ring seals are available. These are easily installed without removing coupling hub and sleeve from shafting.

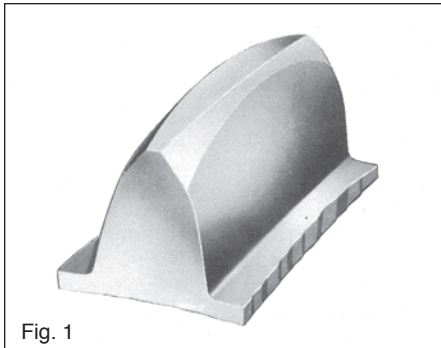


Fig. 1

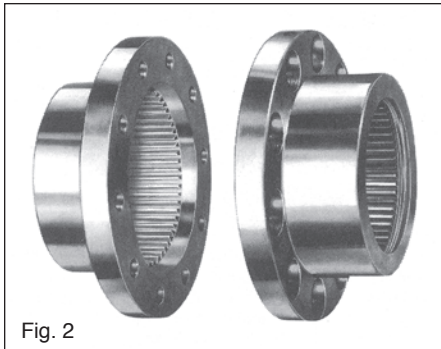


Fig. 2

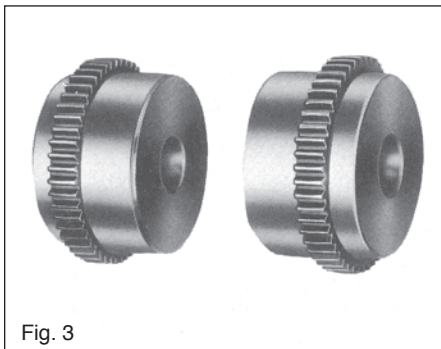


Fig. 3

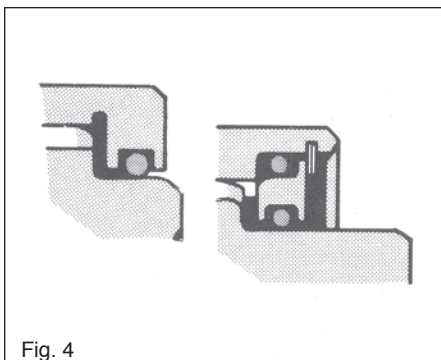
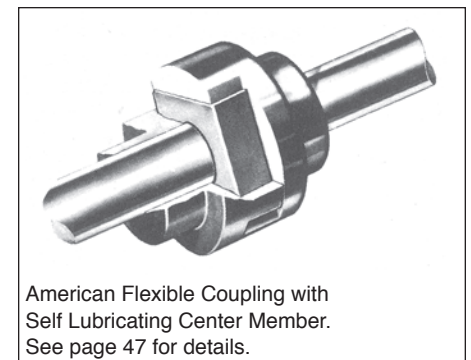


Fig. 4

American®

Operating advantages The American Flexible Coupling is a simplified and efficient unit. It performs all of the required functions of a flexible coupling and compensates for angular misalignment up to $\pm 1^\circ$ in standard applications. But it will compensate for many times this amount without strain to the connected equipment or loss of power for short periods, should an unforeseen alignment condition arise. It is ideal for blind assembly or vertical applications.

The Coupling functions basically on the well-known “Oldham” principle, modified and improved to accommodate maximum shaft misalignment with greater efficiency, easy installation, inspection and servicing. It transmits torque through an intermediate square floating member, and compensates for all three types of misalignments by the combined sliding actions between the closely fitting center member and the adjacent driving and driven jaw flanges.



American Flexible Coupling with Self Lubricating Center Member. See page 47 for details.

Amerigear

Flexible Couplings

Ordering Information

1. Obtain Shaft Sizes Compare shaft sizes of driving and driven equipment with listed maximum bores of desired Series or Type coupling to determine "tentative" coupling size.

NOTE: Maximum bores are listed on pages 8 and 9 for F Type couplings and on page 29 for C Type couplings.

2. Compute effective HP/100 RPM or torque to be transmitted Select a service factor from adjacent table. Determine HP/100 RPM as follows:

$$\text{HP/100 RPM (effective)} = \frac{\text{HP transmitted} \times 100 \times \text{S.F.}}{\text{RPM}}$$

or determine Torque (in.-lbs.) as follows:

$$\text{Torque (effective)} = \frac{\text{HP/100} \times 630}{\text{effective}}$$

or

$$\text{Torque (effective)} = \frac{\text{HP transmitted} \times 63,000 \times \text{S.F.}}{\text{RPM}}$$

Confirm "Tentative" Coupling size or increase to a size which has a HP/100 RPM or torque rating equal to or greater than value computed above.

3. Check Maximum Speed of Application Refer to page 34 for maximum speed ratings. These speeds are given only as a guide, since the maximum speed depends on the system characteristics.

4. Check Space Limitations Dimensions of the selected coupling should be compared with space provided in the application to assure proper clearances. Shaft extensions, separation, and clearances to align coupling should be checked.

Example A 250-HP electric motor is to drive a centrifugal pump at 1750 RPM. Motor shaft size is 2¹/₂". Pump shaft size is 2". Bore size for Series F and Series C, Size 202 will accommodate the 2¹/₂" shaft.

$$\text{HP/100 RPM} = \frac{250 \times 100 \times 1.5}{1750} = 21.4$$

Both Series F and Series C, Size 202 have capacities of 50 HP/100 RPM.

Note: Series F and Series C, Size 202 will accommodate a 2³/₄" shaft with standard square key. In this example, the rating of 50 HP/100 RPM provides a large margin of safety.

Recommended Service Factors (S.F.)

In order to provide for the dynamic torque which must be transmitted, it may be necessary to increase the horsepower to be transmitted by a factor which will allow for momentary increases in torque due to the characteristics of the equip-

ment. The service factors shown in the table below provide a basis for estimating this allowance for specific combination of connected equipment.

These factors are derived from lengthy service experience with average applications — and they are to be considered as a general guide. For conditions not covered by the table, good judgment must be exercised and a factor selected by referring to the type of equipment most closely approximating the type of application being considered, or by detailed analysis of the dynamics of the equipment.

LOAD	DRIVEN EQUIPMENT	TYPE DRIVER		
		Motor or Turbine	Hydraulic Drive	Reciprocating Engine
UNIFORM	Centrifugal Pumps • Conveyors — Even Loaded • Exciters • Fans and Blowers — Light Duty • Generators — Even Loaded • Mixers — Liquid	1.0	1.25	1.50
LIGHT SHOCK	Centrifugal Pumps • Generators — Pulsating Load • Grinders • Hydraulic Pumps • Kilns • Line Shafting • Machine Tools • Oscillating Pumps • Textile Machinery • Woodworking Machinery	1.5	1.75	2.0
MEDIUM SHOCK	Air Compressors — Multi-Cylinder • Ball and Rod Mills • Cranes • Elevators • Hoists • Punch Presses • Reciprocating Pumps • Shears • Ship Drives • Welding Generators	2.0	2.25	2.5
HEAVY SHOCK	Air Compressors — Single Cylinder • Dredges • Drilling Rigs • Mine Machinery • Rolling Mill Drives • Rubber Mixers	2.5	2.75	3.0
EXTREME SHOCK	Ore Crushers • Barstock Shears • Vibrating Conveyors	3.0	3.5	4.0

For operating speeds less than 100 RPM, service factors may be reduced depending upon application. Refer to Ameridrives International for appropriate recommendations.

When Ordering, Specify Following Information

- Quantity and delivery requirements.
- Shaft or bore sizes and keyway dimensions. Give exact dimensions with tolerances.
- Load — horsepower and/or torque at a specific RPM. State normal and maximum conditions.
- Speed — minimum, normal and maximum.
- Application — type of driver and driven equipment.
- Coupling Series, Type and Size.
- Space limitations — envelope dimensions, shaft extensions and shaft spacing.
- Unusual misalignment conditions.
- Modifications — setscrews, tapered bores, special keys, hub cut-off, counterbores or others.
- Unusual operating conditions — ambient temperatures and atmospheres.

Specify Following Information for Specific Couplings

Series FM and CM — Mill-motor Type: Motor frame number plus drawing detail of shaft if possible.

Series FE — Spacer Type: Shaft separation: Specify shrouded or exposed bolt.

Series FS and CS — Tandem Type:

State if floating shaft to be supplied. Specify mounting arrangement and shaft spacing.

Series FA and CA — Axial Travel Type: Amount of travel. Shaft extension and separation.

Series FD, FDC — Disconnect Type: Specify which bore is to be in the disengaging hub. Describe shifting mechanism.

Series FPH, FSPH — Shear Pin: State shear torque and quantity of spare shear pins.

Limited End Float Variation: Specify allowable end float.

Recommended Bore Tolerances

- Recommended standard bore tolerances for interference and clearance fits are shown in Tables A and B respectively.
- Bore tolerances conform to AGMA 9002-A86 standards.

Interference Fits Unless specified, bores will be furnished with an interference fit.

When **shaft sizes only** are stated on order and they consist of fractional or decimal dimensions without tolerance, the bore will be sized for an interference fit in accordance with Table A. If exact **shaft size** and tolerance do not agree with tables, the largest shaft dimension will be considered “basic” and the standard negative bore tolerance will be applied.

Nominal Bore Size Over Thru	Shaft Tolerance	Bore Tolerance	Interference Range
0.0000 / 1.5000	+0.0000 -0.0005	-.0005/-0.0010	-.0000/-0.0010
1.5000 / 3.0000	+0.0000 -0.0010	-.0010/-0.0020	-.0000/-0.0020
3.0000 / 4.0000		-.0015/-0.0030	-.0005/-0.0030
4.0000 / 5.0000		-.0020/-0.0035	-.0010/-0.0035
5.0000 / 7.0000		-.0025/-0.0040	-.0015/-0.0040
7.0000 / 8.0000		-.0030/-0.0050	-.0020/-0.0050
8.0000 / 9.0000		-.0035/-0.0055	-.0025/-0.0055
9.0000 / 10.0000		-.0040/-0.0060	-.0030/-0.0060
10.0000 / 11.0000		-.0045/-0.0065	-.0035/-0.0065
11.0000 / 12.0000		-.0050/-0.0070	-.0040/-0.0070
12.0000 / 13.0000		-.0055/-0.0075	-.0045/-0.0075
13.0000 / 14.0000	-.0060/-0.0080	-.0050/-0.0080	
14.0000 / 15.0000	-.0065/-0.0085	-.0055/-0.0085	
15.0000 / 16.0000	-.0065/-0.0090	-.0055/-0.0090	
16.0000 / 17.0000	-.0070/-0.0095	-.0060/-0.0095	
17.0000 / 18.0000	-.0075/-0.0100	-.0065/-0.0100	
18.0000 / 19.0000	-.0080/-0.0105	-.0070/-0.0105	
19.0000 / 20.0000	-.0085/-0.0110	-.0075/-0.0110	
20.0000 / 22.0000	+0.0000 -0.0020	-.0100/-0.0130	-.0080/-0.0130
22.0000 / 24.0000		-.0110/-0.0140	-.0090/-0.0140
24.0000 / 26.0000		-.0120/-0.0150	-.0100/-0.0150

Clearance Fits If **shaft sizes** are listed as fractional or decimal dimensions without tolerance, the bore will be sized in accordance with Table B. If **exact shaft size** and tolerance are given, but tolerance does not agree with Table B, the largest shaft dimension will be considered as “basic” and the standard bore tolerance will be applied.

Table B conforms to AGMA 9002-A86 Class I.

Nominal Bore Range	Shaft Tolerance	Bore Tolerance	Clearance Range
Thru 1.5000	+0.0000 -0.0005	+0.0010 -0.0000	+0.0015 -0.0000
Over 1.5000 Thru 2.0000	+0.0000 -0.0010	+0.0010 -0.0000	+0.0020 -0.0000
Over 2.0000 Thru 6.5000		+0.0015 -0.0000	+0.0025 -0.0000

Example

Shaft Size — 2.000 (Basic Size)
1.999 (With Tolerance)

Interference Fit

Coupling Bore 1.999
1.998

Clearance Fit

Coupling Bore 2.001
2.000

Nominal Bore Range		Keyway (Inches)		
Over	Thru	Width	Depth Sq.Key	Depth Red. Key
.312	/ .438	.094	.047	-
.438	/ .562	.125	.063	.047
.562	/ .875	.188	.094	.062
.875	/ 1.250	.250	.125	.094
1.250	/ 1.375	.312	.156	.125
1.375	/ 1.750	.375	.188	.125
1.750	/ 2.250	.500	.250	.188
2.250	/ 2.750	.625	.313	.219
2.750	/ 3.250	.750	.375	.250
3.250	/ 3.750	.875	.438	.313
3.750	/ 4.500	1.000	.500	.375
4.500	/ 5.500	1.250	.625	.438
5.500	/ 6.500	1.500	.750	.500
6.500	/ 7.500	1.750	.875	.750
7.500	/ 9.000	2.000	1.000	.750
9.000	/ 11.000	2.500	1.250	.875
11.000	/ 13.000	3.000	1.500	1.000
13.000	/ 15.000	3.500	1.750	1.250
15.000	/ 18.000	4.000	-	1.500
18.000	/ 22.000	5.000	-	1.750
22.000	/ 26.000	6.000	-	2.000

Amerigear

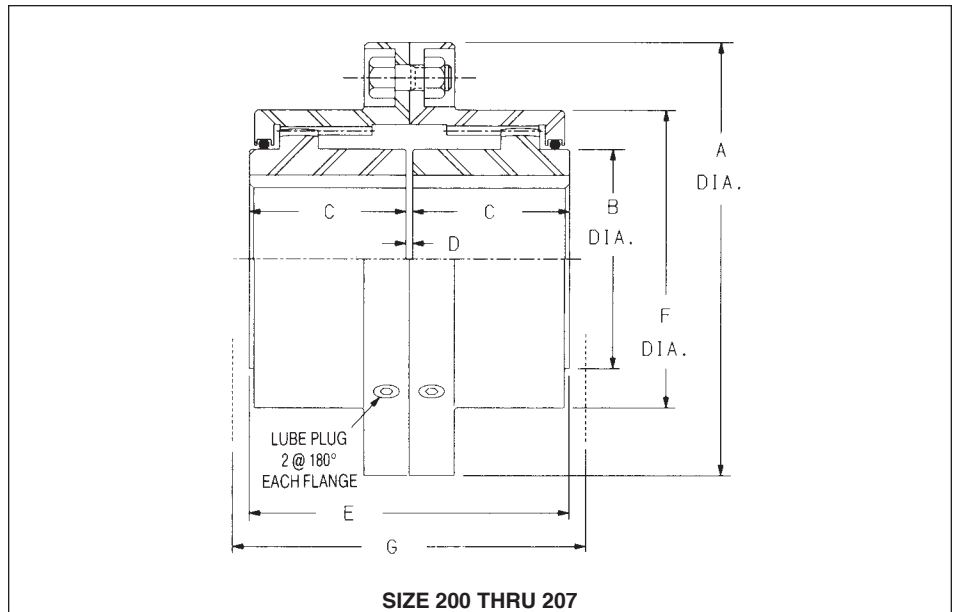
Flexible Couplings

Series F Sizes 200-207

Flanged Sleeve – Double-Engagement Type

Application: Meets requirements of all standard applications for shaft sizes up to 10.25 diameter. Compensates for all three types of misalignment.

Description: Amerigear 200 Series F Flexible Coupling is designed with bolted center flanges to facilitate installation and alignment. Optimum separation of gear meshes permits high parallel offset capacity. Flanged-sleeve design makes possible minimum distances between bearing housings to facilitate shaft alignment. In addition, 200 Series hubs are designed with a greater bore capacity.



F Size	Maximum Bore		Parallel Offset Capacity	Load Capacity		DIMENSIONS						
	Square Key	Reduced Key		HP Per 100 R.P.M.	Torque in.-Lbs x 10 ³	A	B	C	D	E	F	G**
* 200	.81	.88	.023	3	1.9	2.94	1.25	1.06	.12	2.25	1.94	2.88
* 201	1.25	1.31	.042	5	3.2	3.56	1.75	1.38	.12	2.88	2.56	3.50
* 201 ¹ / ₄	1.63	1.75	.057	12	7.6	4.00	2.25	1.69	.12	3.50	3.00	4.12
201 ¹ / ₂	2.25	2.38	.058	27	17.0	6.00	3.12	1.94	.12	4.00	3.92	4.75
202	2.75	2.88	.079	50	31.5	7.00	4.00	2.44	.12	5.00	4.86	6.00
202 ¹ / ₂	3.50	3.75	.102	85	53.6	8.38	4.88	3.03	.19	6.25	5.86	7.25
203	4.00	4.25	.119	150	94.5	9.44	5.75	3.59	.19	7.38	6.86	8.50
203 ¹ / ₂	4.50	4.75	.142	225	142.0	11.00	6.50	4.19	.25	8.62	7.88	10.00
204	5.50	5.88	.164	340	214.0	12.50	7.75	4.75	.25	9.75	9.22	11.00
204 ¹ / ₂	6.25	6.75	.187	515	324.0	13.62	9.00	5.31	.31	10.94	10.35	12.25
205	6.62	6.75	.218	660	416.0	15.31	9.50	6.03	.31	12.38	11.44	13.75
205 ¹ / ₂	7.50	7.62	.245	875	551.0	16.56	10.50	6.62	.31	13.56	12.69	15.25
206	8.25	8.62	.275	1,190	750.0	18.00	11.75	7.41	.31	15.12	13.75	16.50
207	9.62	10.25	.314	1,640	1,033.0	20.75	13.50	8.69	.38	17.75	16.00	19.25

* SIZES 200, 201 AND 201¹/₄ FLANGE FASTENERS ARE SELF-LOCKING SOCKET HEAD CAP SCREWS — ONE FLANGE TAPPED.

SIZES 201¹/₂-205¹/₂ HAVE SHROUDED BOLTS (SB) WITH SELF-LOCKING NUTS; EXPOSED BOLTS (EB) UPON REQUEST — NO ADDITIONAL COST. **CLEARANCE FOR ALIGNING COUPLING.

SIZES 206 AND 207 HAVE EXPOSED BOLTS (EB) WITH SELF-LOCKING NUTS.

MAXIMUM BORE, KEYWAY AND PULLER HOLE DATA, PAGE 40. CENTER FLANGE DETAILS, PAGE 41. ADDITIONAL DETAILS, PAGE 42. WEIGHTS AND WR², PAGE 38. MODIFICATIONS AND VARIATIONS, PAGES 23-28. MAXIMUM SPEEDS, PAGE 34.

COMBINED ANGULAR AND PARALLEL OFFSET SHOULD NOT EXCEED ± 1¹/₂° PER GEAR MESH.

Amerigear Flexible Couplings - Fully-Crowned Teeth For Higher Torque, Higher Speed, Higher Misalignment Capacity
All Amerigear Series F Couplings incorporate the following engineered features:

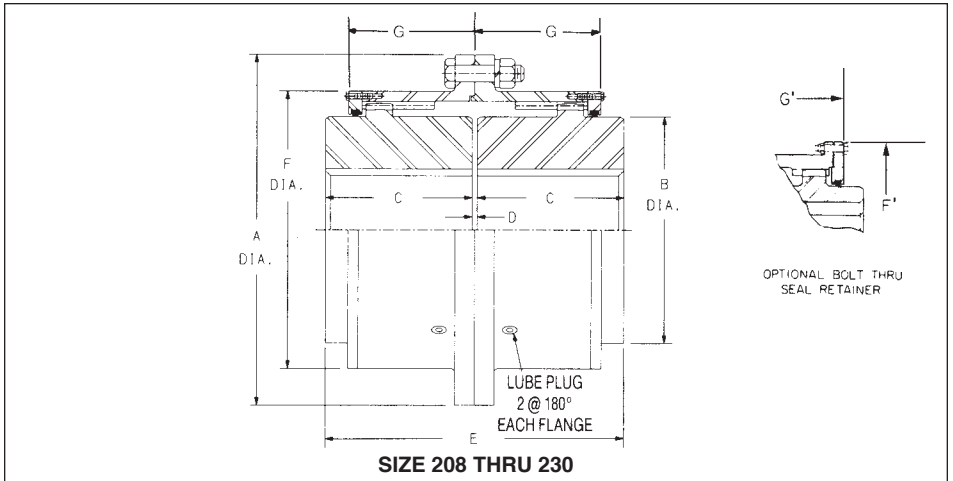
- ±1¹/₂° angular misalignment capacity per gear mesh.
- Torque ratings at full misalignment - in excess of normal requirements for average applications.
- Accurately machined medium carbon steel hubs and sleeves.
- Positive-type O-ring seals keep lubricant in ... contaminants out. Seals enshrouded to prevent damage.

Series F Sizes 208-230

Flanged Sleeve – Double-Engagement Type

Application: Meets requirements of severe service conditions and larger shaft sizes up to 46" diameter. Compensates for all three types of misalignment.

Description: Heavy-duty Amerigear Series F Flexible Coupling (Sizes 208-230) contains the same basic design features as Series F (Sizes 200-207), described on page 8 . . . however, misalignment capacity is $\pm 3/4^\circ$. Major components are fully-machined from medium carbon steel.



F Size	LOAD CAPACITY*		Parallel Offset Capacity In.	DIMENSIONS									
	HP Per 100 RPM	Torque In.-Lbs. x10 ⁶		A	B	C	D	E	F	G	Opt. Bolt Through Seal Retainer		
											Parallel Offset	F'	G'
208	2,380	1.50	.164	23.25	15.62	9.75	.38	19.88	18.38	8.38	.164	20.62	8.38
209	2,700	1.70	.181	26.00	17.50	10.75	.50	22.00	20.50	9.19	.181	22.75	9.19
210	3,300	2.08	.200	28.00	19.00	12.00	.50	24.50	22.38	10.00	.200	25.12	10.00
211	5,800	3.65	.216	30.50	21.00	13.00	.50	26.50	24.75	10.91	.216	26.75	10.91
212	7,700	4.86	.228	33.00	23.00	14.00	.50	28.50	26.75	11.59	.228	28.75	11.59
213	10,000	6.31	.249	35.75	25.00	15.00	.75	30.75	28.75	12.47	.249	30.75	12.47
214	12,700	8.02	.262	38.00	27.00	16.00	.75	32.75	30.75	13.09	.262	32.75	13.09
215	15,300	9.65	.275	40.50	29.00	17.00	.75	34.75	32.75	13.72	.275	35.50	13.72
216	17,400	10.96	.203	44.50	30.50	18.00	1.00	37.00	35.50	11.34	.294	39.50	14.84
218	23,200	14.62	.203	48.50	34.50	20.00	1.00	41.00	39.50	11.47	.347	43.50	16.97
220	30,000	18.95	.203	52.50	38.50	22.00	1.00	45.00	43.50	11.59	.399	48.00	19.09
222	38,000	23.98	.203	58.00	42.50	24.00	1.00	49.00	48.00	11.75	.451	52.00	21.50
224	48,800	30.72	.203	62.88	46.50	26.00	1.00	53.00	52.00	11.91	.504	56.00	23.41
226	63,000	39.70	.203	69.00	50.00	28.00	1.00	57.00	57.00	12.22	.556	61.00	25.72
228	81,900	51.61	.203	73.00	54.00	30.00	1.00	61.00	61.00	12.69	.609	65.00	28.13
230	94,800	59.70	.203	77.00	58.00	32.00	1.00	65.00	65.00	12.69	.609	69.00	28.13

*IF HIGHER TORQUE CAPACITY IS REQUIRED AND SIZE IS RESTRICTED, CONSULT AMERIDRIVES INTERNATIONAL.

CENTER FLANGE DETAILS, PAGE 41. ADDITIONAL DETAILS, PAGE 43. WEIGHTS AND WR2, PAGE 39. MODIFICATIONS AND VARIATIONS, PAGES 23-28. LARGER SIZES AVAILABLE. MAXIMUM SPEEDS, PAGE 34.

SIZES 208-230 HAVE EXPOSED BOLTS.

SINGLE AND DOUBLE KEY BORE CAPACITY – FLEXIBLE HUBS

F Size	1 SQUARE KEY			1 REDUCED KEY				2 SQUARE KEYS			2 REDUCED KEYS				
	Max. Bore Inches	Keyway		Max. Bore Inches	Keyway		K* Inches	Max. Bore Inches	Keyways		Max. Bore Inches	Keyways		K* Inches	
	W. - Inches	H. - Inches		W. - Inches	H. - Inches		W. - Inches	H. - Inches		W. - Inches	H. - Inches		W. - Inches	H. - Inches	
208	11.250	2.500	1.250	12.250	2.500	.812	6.823	12.000	1.750	.875	12.750	1.750	.625	6.953	
209	12.250	3.000	1.500	13.375	3.000	1.000	7.531	13.500	2.000	1.000	14.500	2.000	.688	7.875	
210	13.750	3.000	1.500	15.000	3.000	1.000	8.360	14.875	2.000	1.000	15.750	2.000	.688	8.500	
211	14.250	3.500	1.750	15.250	3.500	1.250	8.703	15.500	2.750	1.375	16.500	2.750	.875	9.000	
212	15.250	3.750	1.875	16.250	3.750	1.375	9.281	17.000	3.000	1.500	18.000	3.000	1.000	9.937	
213	16.250	4.000	2.000	17.250	4.000	1.500	9.875	18.500	3.250	1.625	19.500	3.250	1.125	10.750	
214								20.000	3.500	1.750	21.000	3.500	1.250	11.625	
215								21.500	3.500	1.750	22.500	3.500	1.250	12.375	
216								23.000	3.750	1.875	24.000	3.750	1.375	13.250	
218								26.000	4.000	2.000	27.000	4.000	1.500	14.875	
220								29.000	4.500	2.250	30.000	4.500	1.750	16.562	
222								31.750	5.000	2.500	33.000	5.000	1.875	18.187	
224								34.500	6.000	3.000	36.000	6.000	2.250	20.000	
226								37.000	6.000	3.000	39.000	6.000	2.250	21.562	
228								40.000	6.000	3.000	42.000	6.000	2.250	23.062	
230								44.000	6.000	3.000	46.000	6.000	2.250	25.062	

NOTE: SINGLE KEYS NOT RECOMMENDED FOR SIZES 214 AND LARGER. CONSULT AMERIDRIVES INTERNATIONAL IF DOUBLE KEYS NOT PRACTICAL.

*MAXIMUM DISTANCE FROM BOTTOM OF KEYWAY TO BORE AXIS.

MAXIMUM BORES AND PULLER HOLE DATA, PAGE 40.

Amerigear

Flexible Couplings

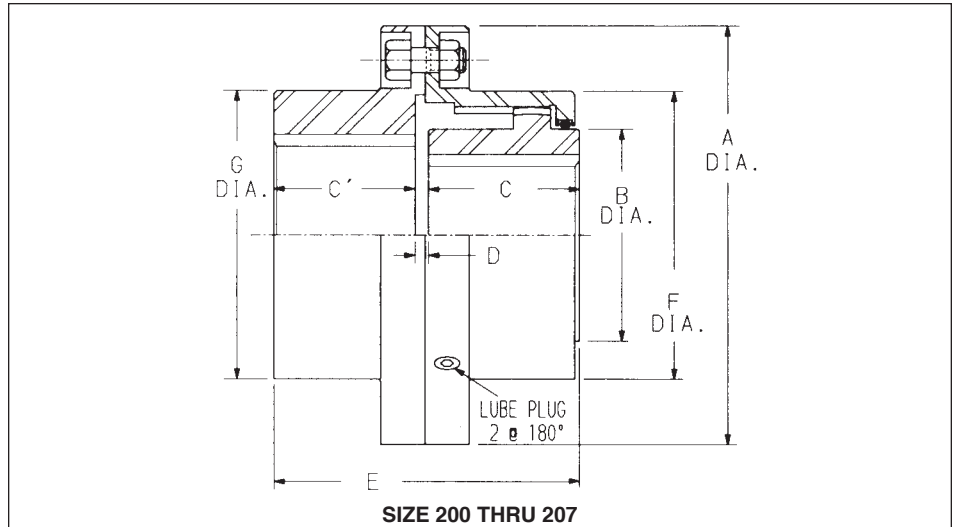
Series FS Sizes 200-207

Flanged Sleeve – Single-Engagement Type

Application: Used primarily in tandem pairs, connected by intermediate floating shaft ... or as individual unit in conjunction with a driver or driven shaft having a self-aligning support bearing. When used singly, compensates for angular misalignment only.

Description: Amerigear Series FS Flexible Coupling consists of one standard flexible half coupling and one rigid half. The bolted center flanges facilitate installation and alignment.

If used in tandem assemblies, see page 24 for shaft sizes and page 37 for speed limits.



F Size	Max. Bore Flex Half		Max. Bore Rigid Half		Load Capacity		DIMENSIONS							
	Square Key	Reduced Key	Square Key	Reduced Key	HP Per 100 R.P.M.	Torque In.-Lbs x 10 ³	A	B	C	C'	D	E	F	G*
* 200	.81	.88	1.31	1.38	3	1.9	2.94	1.25	1.06	1.05	.08	2.25	1.94	1.94
* 201	1.25	1.31	1.75	1.88	5	3.2	3.56	1.75	1.38	1.23	.08	2.88	2.56	2.56
* 201 ¹ / ₄	1.63	1.75	2.00	2.13	12	7.6	4.00	2.25	1.69	1.48	.08	3.50	3.00	3.00
201 ¹ / ₂	2.25	2.38	2.69	2.88	27	17.0	6.00	3.12	1.94	1.78	.16	4.00	3.92	3.92
202	2.75	2.88	3.25	3.50	50	31.5	7.00	4.00	2.44	2.28	.16	5.00	4.86	4.86
202 ¹ / ₂	3.50	3.75	4.00	4.25	85	53.6	8.38	4.88	3.03	2.91	.19	6.25	5.86	5.86
203	4.00	4.25	4.62	5.00	150	94.5	9.44	5.75	3.59	3.41	.19	7.38	6.86	6.86
203 ¹ / ₂	4.50	4.75	5.38	5.75	225	142.0	11.00	6.50	4.19	3.97	.22	8.62	7.88	7.88
204	5.50	5.88	6.25	6.75	340	214.0	12.50	7.75	4.75	4.44	.31	9.75	9.22	9.22
204 ¹ / ₂	6.25	6.75	6.88	7.38	515	324.0	13.62	9.00	5.31	5.00	.34	10.94	10.35	10.18
205	6.62	6.75	7.88	8.38	660	416.0	15.31	9.50	6.03	5.75	.34	12.38	11.44	11.44
205 ¹ / ₂	7.50	7.62	8.75	9.25	875	551.0	16.56	10.50	6.62	6.12	.34	13.56	12.69	12.69
206	8.25	8.62	9.38	9.88	1,190	750.0	18.00	11.75	7.41	7.16	.41	15.12	13.75	13.75
207	9.62	10.25	10.75	11.50	1,640	1,033.0	20.75	13.50	8.69	8.44	.50	17.75	16.00	15.75

*SIZES 200, 201 AND 201¹/₄ FLANGE FASTENERS ARE SELF-LOCKING SOCKET HEAD CAP SCREWS - RIGID FLANGE TAPPED.

SIZES 201¹/₂ - 205¹/₂ HAVE SHROUDED BOLTS (SB) WITH SELF-LOCKING NUTS: EXPOSED BOLTS (EB) AVAILABLE UPON REQUEST — NO ADDITIONAL COST.

SIZES 206 AND 207 HAVE EXPOSED BOLTS (EB) WITH SELF-LOCKING NUTS.

MAXIMUM BORE, KEYWAY AND PULLER HOLE DATA, PAGE 40. CENTER FLANGE DETAILS, PAGE 41. ADDITIONAL DETAILS, PAGE 42. WEIGHTS AND WR², PAGE 38. MODIFICATIONS AND VARIATIONS, PAGES 23-28. MAXIMUM SPEEDS, PAGE 34.

COMBINED ANGULAR AND PARALLEL OFFSET SHOULD NOT EXCEED ±1¹/₂° PER GEAR MESH.
PILOT RINGS AVAILABLE. SEE PAGE 41 FOR DIMENSIONS OF PILOT RINGS.

Amerigear Flexible Couplings - Fully-Crowned Teeth For Higher Torque, Higher Speed, Higher Misalignment Capacity
All Amerigear Series FS Couplings incorporate the following engineered features:

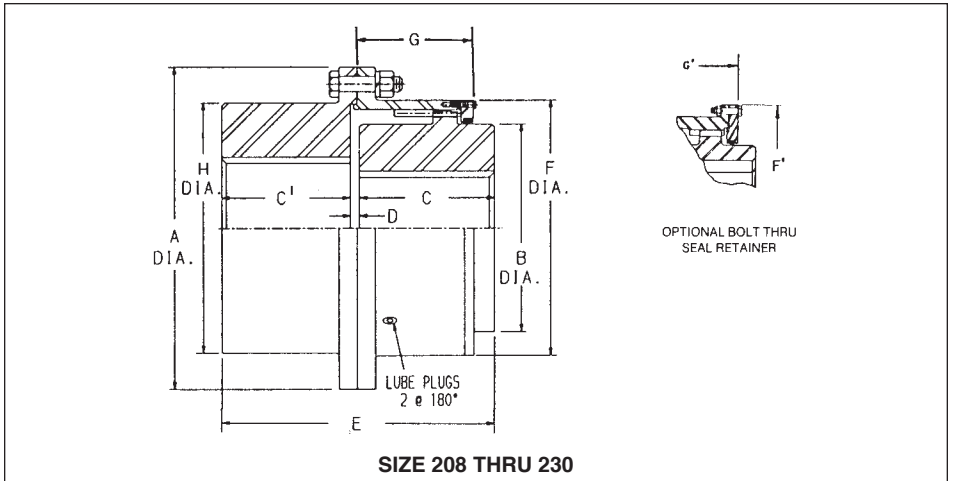
- ±1¹/₂° angular misalignment capacity per gear mesh. Used singly, can only accommodate angular misalignment.
- Torque ratings at full misalignment - in excess of normal requirements for average applications.
- Accurately machined medium carbon steel hubs and sleeves.
- Positive-type O-ring seals keep lubricant in ... contaminants out. Seals enshrouded to prevent damage.

Series FS Sizes 208-230

Flanged Sleeve – Single-Engagement Type

Application: Meets requirements of severe service conditions and larger shaft sizes up to 49" diameter. Used primarily in tandem pairs, connected by intermediate floating shaft... or as individual unit in conjunction with a driver or driven shaft having a self-aligning bearing. When used singly, compensates for angular misalignment only.

Description: Amerigear Series FS Flexible Coupling (Sizes 208-230) contains the same basic design features as Series FS (Sizes 200-207), described on page 10 ... however, angular misalignment capacity is $\pm 3/4^\circ$. Major components are fully-machined from medium carbon steel.



FS Size	LOAD CAPACITY*		DIMENSIONS									Optional Bolt Thru Seal Retainer	
	HP Per 100 RPM	Torque In.-Lbs. x10 ⁶	A	B	C	C'	D	E	F	G	H	F'	G'
208	2,380	1.50	23.25	15.62	9.75	9.62	.50	19.88	18.38	8.38	18.00	20.62	8.38
209	2,700	1.70	26.00	17.50	10.75	10.69	.56	22.00	20.50	9.19	20.00	22.75	9.19
210	3,300	2.08	28.00	19.00	12.00	11.88	.62	24.50	22.38	10.00	22.00	25.12	10.00
211	5,800	3.65	30.50	21.00	13.00	12.88	.62	26.50	24.75	10.91	24.75	26.75	10.91
212	7,700	4.86	33.00	23.00	14.00	13.88	.62	28.50	26.75	11.59	26.75	28.75	11.59
213	10,000	6.31	35.75	25.00	15.00	15.00	.75	30.75	28.75	12.47	28.75	30.75	12.47
214	12,700	8.02	38.00	27.00	16.00	16.00	.75	32.75	30.75	13.09	30.75	32.75	13.09
215	15,300	9.65	40.50	29.00	17.00	17.00	.75	34.75	32.75	13.72	32.75	35.50	13.72
216	17,400	10.96	44.50	30.50	18.00	18.00	1.00	37.00	35.50	11.34	35.50	39.50	14.84
218	23,200	14.62	48.50	34.50	20.00	20.00	1.00	41.00	39.50	11.47	39.50	43.50	16.97
220	30,000	18.95	52.50	38.50	22.00	22.00	1.00	45.00	43.50	11.59	43.50	48.00	19.09
222	38,000	23.98	58.00	42.50	24.00	23.88	1.12	49.00	48.00	11.75	48.00	52.00	21.50
224	48,800	30.72	62.88	46.50	26.00	25.88	1.12	53.00	52.00	11.91	52.00	56.00	23.41
226	63,000	39.70	69.00	50.00	28.00	27.88	1.12	57.00	57.00	12.22	57.00	61.00	25.72
228	81,900	51.61	73.00	54.00	30.00	29.88	1.12	61.00	61.00	12.69	61.00	65.00	28.13
230	94,800	59.70	77.00	58.00	32.00	31.88	1.12	65.00	65.00	12.69	65.00	69.00	28.13

* IF HIGHER TORQUE CAPACITY IS REQUIRED AND SIZE IS RESTRICTED, CONSULT AMERIDRIVES. LARGER SIZES AVAILABLE.

SIZES 208-230 HAVE EXPOSED BOLTS (EB). CENTER FLANGE DETAILS, PAGE 41. ADDITIONAL DETAILS, PAGE 43. MAXIMUM SPEEDS, PAGE 34. WEIGHTS AND WR², PAGE 39. MODIFICATIONS AND VARIATIONS, PAGES 23-28.

MAXIMUM BORE FOR RIGID HALF

F Size	1 SQUARE KEY			1 REDUCED KEY				2 SQUARE KEYS				2 REDUCED KEYS			
	Max. Bore Inches	Keyway		Max. Bore Inches	Keyway		K* Inches	Max. Bore Inches	Keyways		Max. Bore Inches	Keyways		K* Inches	
	W. - Inches	H. - Inches		W. - Inches	H. - Inches		W. - Inches	H. - Inches		W. - Inches	H. - Inches		W. - Inches	H. - Inches	
208	11.500	3.000	1.500	12.500	3.000	1.000	7.062	12.375	2.000	1.000	13.000	2.000	.688	7.109	
209	12.750	3.250	1.625	13.750	3.250	1.125	7.812	14.000	2.250	1.125	14.750	2.250	.750	8.031	
210	14.500	3.500	1.750	15.250	3.500	1.250	8.796	15.500	2.750	1.375	16.250	2.750	.875	8.984	
211	15.250	3.750	1.875	16.250	3.750	1.375	9.281	16.750	3.000	1.500	17.750	3.000	1.000	9.750	
212	16.250	4.000	2.000	17.250	4.000	1.500	9.828	18.250	3.250	1.625	19.250	3.250	1.125	10.609	
213								19.750	3.500	1.750	20.750	3.500	1.250	11.468	
214								21.500	3.750	1.875	22.500	3.750	.375	12.468	
215								23.000	3.750	1.875	24.000	3.750	.375	13.234	
216								24.500	4.000	2.000	25.500	4.000	.500	14.093	
218								27.750	4.500	2.250	28.750	4.500	.750	15.953	
220								30.500	5.000	2.500	31.750	5.000	.875	17.546	
222								34.000	5.500	2.750	35.000	5.500	2.250	19.531	
224								37.000	6.000	3.000	38.000	6.000	2.500	21.265	
226								40.000	6.500	3.250	41.000	6.500	2.750	23.000	
228								44.000	6.500	3.250	45.000	6.500	2.750	25.062	
230								48.000	7.000	3.500	49.000	7.000	3.000	27.250	

FOR FLEXIBLE HUB BORE CAPACITY (PAGE 9) AND PULLER HOLE DATA (PAGE 40) USE INFORMATION FOR SERIES F.

If used in tandem assemblies, consult Ameridrives for shaft size and speed limits

* MAXIMUM DISTANCE FROM BOTTOM OF KEYWAY TO BORE AXIS. REFERENCE DRAWING ON PAGE 40.

Amerigear

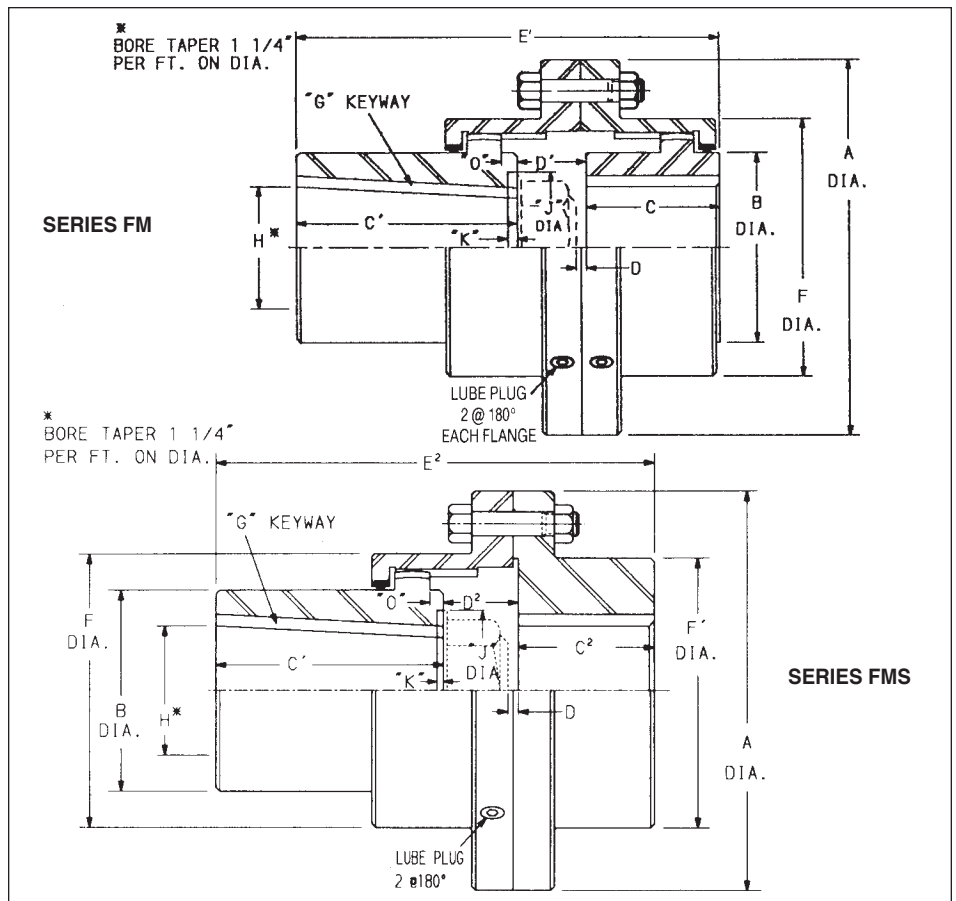
Flexible Couplings

Series FM, FMS Sizes 201¹/₂-206

Flanged Sleeve – Double- and Single-Engagement Mill Motor Type

Application: Designed for modern mill motor applications and standards demanding quick change-out of equipment for continuous and uninterrupted operation.

Description: Amerigear Series FM and FMS Flexible Couplings are designed with bolted center flanges to facilitate installation and alignment. Optimum separation of gear meshes permits relatively high parallel offset capacity. Flanged-sleeve design makes possible minimum distances between bearing housings to facilitate shaft alignment.



FM, FMS Size	Load Capacity		Parallel Offset Capacity In.	DIMENSIONS							
	HP Per 100 R.P.M.	Torque In.-Lbs x 10 ³		FM				FMS			
				A	B	F	F'	C	D	C2	D
201 ¹ / ₂	27	17.0	.058	6.00	3.12	3.92	3.92	1.94	.12	1.78	.16
202	50	31.5	.079	7.00	4.00	4.86	4.86	2.44	.12	2.28	.16
202 ¹ / ₂	85	53.6	.102	8.38	4.88	5.86	5.86	3.03	.19	2.91	.19
203	150	94.5	.119	9.44	5.75	6.86	6.86	3.59	.19	3.41	.19
203 ¹ / ₂	225	142.0	.142	11.00	6.50	7.88	7.88	4.19	.25	3.97	.22
204	340	214.0	.164	12.50	7.75	9.22	9.22	4.75	.25	4.44	.31
204 ¹ / ₂	515	324.0	.187	13.62	9.00	10.35	10.18	5.31	.31	5.00	.34
205	660	416.0	.218	15.31	9.50	11.44	11.44	6.03	.31	5.75	.34
205 ¹ / ₂	875	551.0	.245	16.56	10.50	12.69	12.69	6.62	.31	6.12	.34
206	1,190	750.0	.275	18.00	11.75	13.75	13.75	7.41	.31	7.16	.41

Amerigear Flexible Couplings - Fully-Crowned Teeth For Higher Torque, Higher Speed, Higher Misalignment Capacity
All Amerigear Series FM-FMS Couplings incorporate the following engineered features:

- Series FM compensates for all three types of misalignment. Series FMS compensates for angular misalignment.
- ±1¹/₂° angular misalignment capacity per gear mesh.
- Torque ratings at full 1¹/₂° misalignment.
- Accurately machined medium carbon steel hubs and sleeves.
- Positive-type O-ring seals keep lubricant in ... contaminants out. Seals enshrouded to prevent damage.

FM, FMS Size	AISE Frame No.		DIMENSIONS						VARIABLE DIMENSIONS			
			C'	O	K	J	G	H Bore @ Large End	FM		FMS	
							Keyway		D'	E'	D ²	E ²
201½	602	802	3.16	—	.16	2.81	.500 x .250	1.7485/1.7495	.91	6.00	.94	5.88
	603,604	803,804	3.72	—	.22	2.81	.500 x .250	1.998/1.999	.91	6.56	.94	6.44
202	602	802	3.00	.19			.500 x .250	1.7485/1.7495	1.06	6.50	1.09	6.38
	603,604	803,804	3.50	.12			.500 x .250	1.998/1.999	1.12	7.06	1.16	6.94
	606	806	4.00	—			.500 x .250	2.498/2.499	1.25	7.69	1.28	7.56
202½	602	802	3.00	.55			.500 x .250	1.7485/1.7495	1.12	7.16	1.12	7.03
	603,604	803,804	3.50	.48			.500 x .250	1.998/1.999	1.19	7.72	1.19	7.59
	606	806	4.00	.36			.500 x .250	2.498/2.499	1.31	8.34	1.31	8.22
	608	808	4.50	.23			.750 x .250	2.998/2.999	1.44	8.97	1.44	8.84
	610	810	4.50	.11			.750 x .250	3.248/3.249	1.56	9.09	1.56	8.97
	612	812	5.02	—	.015	4.25	.750 x .250	3.623/3.624	1.67	9.72	1.67	9.59
203	604	804	3.50	.75			.500 x .250	1.998/1.999	1.19	8.28	1.19	8.09
	606	806	4.00	.62			.500 x .250	2.498/2.499	1.31	8.91	1.31	8.72
	608	808	4.50	.50			.750 x .250	2.998/2.999	1.44	9.53	1.44	9.34
	610	810	4.50	.38			.750 x .250	3.248/3.249	1.56	9.66	1.56	9.47
	612	812	5.00	.25			.750 x .250	3.623/3.624	1.69	10.28	1.69	10.09
	614	814	5.00	.12			1.000 x .375	4.2470/4.2485	1.81	10.41	1.81	10.22
203½	606	806	4.00	.97			.500 x .250	2.498/2.499	1.38	9.50	1.34	9.31
	608	808	4.50	.84			.750 x .250	2.998/2.999	1.50	10.19	1.47	9.94
	610	810	4.50	.72			.750 x .250	3.248/3.249	1.62	10.31	1.59	10.06
	612	812	5.00	.59			.750 x .250	3.623/3.624	1.75	10.94	1.72	10.69
	614	814	5.00	.47			1.000 x .375	4.2470/4.2485	1.88	11.06	1.84	10.81
	616	816	5.50	.34			1.250 x .375	4.6220/4.6235	2.00	11.69	1.97	11.44
204	610	810	4.50	1.06			.750 x .250	3.248/3.249	1.62	10.88	1.69	10.62
	612	812	5.00	.94			.750 x .250	3.623/3.624	1.75	11.50	1.81	11.25
	614	814	5.00	.81			1.000 x .375	4.2470/4.2485	1.88	11.62	1.94	11.38
	616	816	5.50	.69			1.250 x .375	4.6220/4.6235	2.00	12.25	2.06	12.00
	618	818	6.00	1.12			1.250 x .500	4.9970/4.9985	1.56	12.31	1.62	12.06
204½	612	812	5.00	1.30			.750 x .250	3.623/3.624	1.81	12.12	1.84	11.84
	614	814	5.00	1.17			1.000 x .375	4.2470/4.2485	1.94	12.25	1.97	11.97
	616	816	5.50	1.05			1.250 x .375	4.6220/4.6235	2.06	12.88	2.09	12.59
	618	818	6.00	1.48			1.250 x .500	4.9970/4.9985	1.62	12.94	1.66	12.66
	620	—	6.75	1.05			1.500 x .750	5.8720/5.8735	2.06	14.12	2.09	13.84
205	614	814	5.00	1.70			1.000 x .375	4.2470/4.2485	1.94	12.97	1.97	12.72
	616	816	5.50	1.58			1.250 x .375	4.6220/4.6235	2.06	13.59	2.09	13.34
	618	818	6.00	2.02			1.250 x .500	4.9970/4.9985	1.62	13.66	1.66	13.41
	620	—	6.75	1.58			1.500 x .750	5.8720/5.8735	2.06	14.84	2.09	14.59
	622	—	7.25	.95			1.500 x .750	6.2470/6.2485	2.69	15.97	2.72	15.72
205½	616	816	5.50	2.03			1.250 x .375	4.6220/4.6235	2.06	14.19	2.09	13.72
	618	818	6.00	2.47			1.250 x .500	4.9970/4.9985	1.62	14.25	1.66	13.78
	620	—	6.75	2.03			1.500 x .750	5.8720/5.8735	2.06	15.44	2.09	14.97
	622	—	7.25	1.41			1.500 x .750	6.2470/6.2485	2.69	16.56	2.72	16.09
	624	—	9.25	1.41			1.500 x .750	6.9970/6.9985	2.69	18.56	2.72	18.09
206	616	816	5.50	2.53			1.250 x .375	4.6220/4.6235	2.06	14.97	2.16	14.81
	618	818	6.00	2.97			1.250 x .500	4.9970/4.9985	1.62	15.03	1.72	14.88
	620	—	6.75	2.53			1.500 x .750	5.8720/5.8735	2.06	16.22	2.16	16.06
	622	—	7.25	1.91			1.500 x .750	6.2470/6.2485	2.69	17.34	2.78	17.19
	624	—	9.25	1.91			1.500 x .750	6.9970/6.9985	2.69	19.34	2.78	19.19

ALL MILL MOTOR FLANGES HAVE EXPOSED BOLTS (EB). MAXIMUM BORE, KEYWAY AND PULLER HOLE DATA, PAGE 40.

FOR FRAME SIZES NOT SHOWN IN AISE COLUMN AND FOR OTHER TAPER BORE APPLICATIONS, SIZE COUPLING USING LOAD CAPACITIES ON PAGE 12 AND SERVICE FACTORS ON PAGE 6.

MODIFICATIONS AND VARIATIONS, PAGES 23-28.

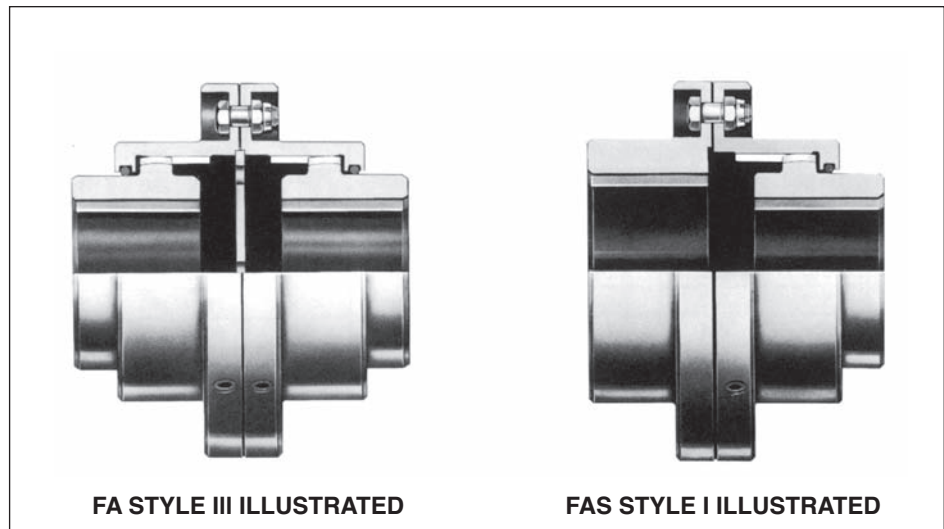
MAXIMUM SPEEDS, PAGE 34.

Amerigear

Flexible Couplings

Series FA, FAS

A multitude of applications exist for axial travel or “slide” couplings. All gear-type couplings permit a minimal amount of travel to accommodate for bearing wear, shaft or rotor float, or thermal expansions. But many drive systems require a greater amount of travel. To fill these requirements Ameridrives has developed a series of axial travel couplings to accommodate most travel requirements. The FA Series includes three coupling styles. The FAS Series includes two styles. The chart below shows the make up of each. If further assistance is required in selecting or designing a coupling with axial travel capacity other than what is shown, consult Ameridrives or your local sales office.



Axial Coupling Type	Style No.	END A		END B	
		Hub Type	Sleeve Type	Hub Type	Sleeve Type
FA	I	Standard Hub Modified	Modified Standard	Universal Hub Modified	Modified Standard
FA	III	Universal Hub Modified	Modified Standard	Universal Hub Modified	Modified Standard
FA	X	Standard	Modified Standard	Special	Long -w/Lip Seal
FAS	I	Rigid	–	Universal Hub Modified	Standard
FAS	v	Rigid	–	Special	Long -w/Lip Seal

Amerigear Flexible Couplings - Fully-Crowned Teeth For Higher Torque, Higher Speed, Higher Misalignment Capacity
All Amerigear Series FA and FAS Couplings incorporate the following engineered features:

- Fully-Crowned Gear Teeth—assures smooth action when adjusting for axial displacement with minimum resistance to slide.
- $\pm 1/2^\circ$ angular misalignment capacity per gear mesh. If greater capacity is required, consult Ameridrives.
- Accurately machined medium carbon steel hubs and sleeves.
- Positive-type O-ring seals keep lubricant in...contaminants out. Seals enshrined to prevent damage.
- Many Series FA hubs are modified standard stock components.
- Many designs available to accommodate most travel requirements.

Series FA, Style I, III

Sizes 201½-207

Style I

End A

Standard Hub Modified
Standard Sleeve Modified

End B

Universal Hub Modified
Standard Sleeve Modified

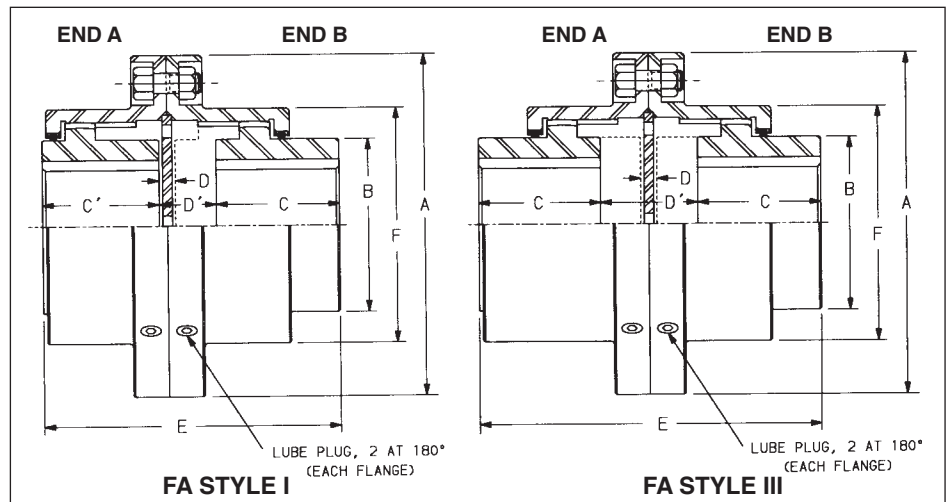
Style III

End A

Universal Hub Modified
Standard Sleeve Modified

End B

Universal Hub Modified
Standard Sleeve Modified



FA Style I Size	*** Parallel Offset Capacity	DIMENSIONS								
		A	B	C	C'	D	D'	E	F	Max. Travel
201½	.016	6.00	3.12	1.94	1.84	.31	.64	4.42	3.92	.33
202	.020	7.00	4.00	2.44	2.34	.31	.98	5.76	4.86	.67
202½	.026	8.38	4.88	3.03	2.94	.38	1.30	7.26	5.86	.92
203	.029	9.44	5.75	3.59	3.50	.38	1.61	8.70	6.86	1.23
203½	.035	11.00	6.50	4.19	4.09	.44	1.91	10.19	7.88	1.47
204	.039	12.50	7.75	4.75	4.56	.62	2.42	11.73	9.22	1.80
204½	.046	13.62	9.00	5.31	5.12	.69	2.52	12.95	10.35	1.83
205	.053	15.31	9.50	6.03	5.84	.69	2.98	14.86	11.44	2.30
205½	.058	16.56	10.50	6.62	6.44	.69	3.47	16.53	12.69	2.78
206	.069	18.00	11.75	7.41	7.16	.81	3.34	17.91	13.75	2.53
207	.084	20.75	13.50	8.69	8.38	1.00	3.62	20.69	16.00	2.62

FA Style III Size	*** Parallel Offset Capacity	DIMENSIONS								
		A	B	C	D	D'	E	F	Max. Travel	
201½	.013	6.00	3.12	1.94	.31	.97	4.84	3.93	.66	
202	.014	7.00	4.00	2.44	.31	1.66	6.53	4.86	1.34	
202½	.018	8.38	4.88	3.03	.38	2.22	8.28	5.88	1.84	
203	.018	9.44	5.75	3.59	.38	2.84	10.03	6.88	2.46	
203½	.022	11.00	6.50	4.19	.44	3.38	11.75	7.91	2.94	
204	.023	12.50	7.75	4.75	.62	4.22	13.72	9.24	3.60	
204½	.030	13.62	9.00	5.31	.69	4.34	14.97	10.37	3.66	
205	.032	15.31	9.50	6.03	.69	5.28	17.34	11.44	4.60	
205½	.033	16.56	10.50	6.62	.69	6.25	19.50	12.69	5.56	
206	.047	18.00	11.75	7.41	.81	5.88	20.69	13.75	5.06	
207	.061	20.75	13.50	8.69	1.00	6.25	23.62	16.00	5.25	

***COMBINED ANGULAR AND PARALLEL OFFSET SHOULD NOT EXCEED $\pm 1/2^\circ$ PER GEAR MESH.

SIZES 201½ - 205½ HAVE SHROUDED BOLTS (SB) WITH SELF-LOCKING NUTS; EXPOSED BOLTS (EB) AVAILABLE UPON REQUEST - NO ADD'L. COST.

SIZES 206 AND 207 HAVE EXPOSED BOLTS (EB) WITH SELF-LOCKING NUTS; SHROUDED BOLTS (SB) UPON REQUEST - NO ADD'L. COST. FOR MAXIMUM BORES AND LOAD CAPACITY, USE SERIES F INFORMATION, PAGE 8.

MAXIMUM BORE, KEYWAY AND PULLER HOLE DATA, PAGE 40. CENTER FLANGE DETAILS, PAGE 41.

TRAVEL AND DIMENSION "E" MAY BE DECREASED BY VARYING D AND D' (CONSULT AMERIDRIVES). MAX. SPEEDS, PAGE 34.

Amerigear

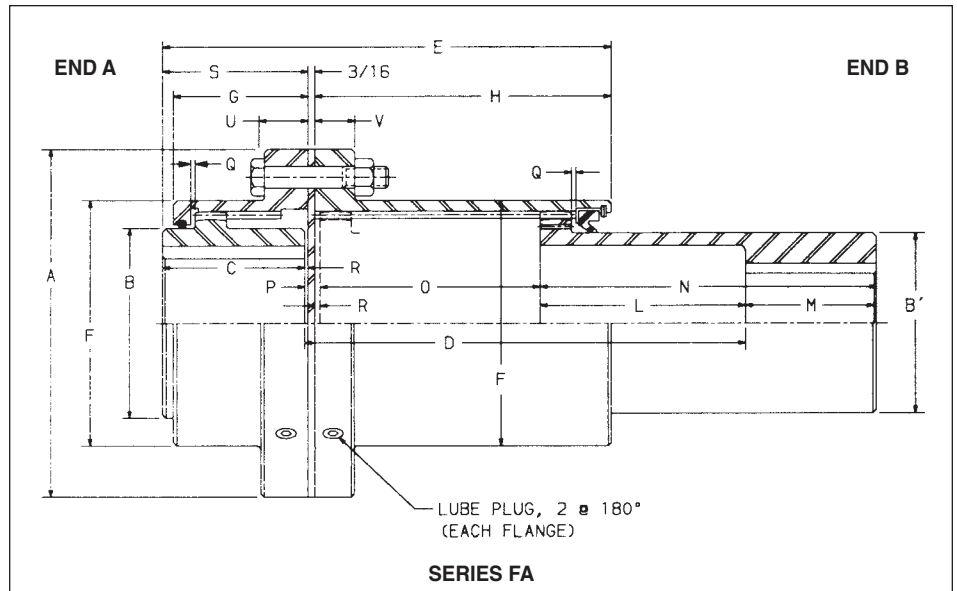
Flexible Couplings

Series FA, Style X Sizes 204-207

Style X

End A
Standard Hub
Standard Sleeve

End B
Special Hub
Long Sleeve with Lip Seal



FA Coupling Size Style X	Max. Bore Flex Half End "B" Square Key	DIMENSIONS									
		A	E	G	F	S	B	B'	C, M	H	L
204	4.50	12.50	17.89	4.46	9.22	4.87	7.75	7.00	4.75	12.83	8.75
204½	5.50	13.62	19.28	4.98	10.35	5.47	9.00	8.38	5.31	13.62	8.44
205	6.31	15.31	20.41	5.67	11.44	6.19	9.50	9.00	6.03	14.03	8.22
205½	6.88	16.56	21.06	6.25	12.69	6.78	10.50	10.00	6.62	14.09	7.69
206	7.50	18.00	21.62	6.89	13.75	7.56	11.75	11.00	7.41	14.01	6.91
207	9.00	20.75	23.37	7.81	16.00	8.87	13.50	13.00	8.69	14.31	6.06

FA Coupling Size Style X	N	U	V	O Maximum Travel	P Hub-To-Hub		Q	R	D Shaft-To-Shaft	
					Min.	Max.			Min.	Max.
204	13.50	1.06	.87	10.62	.44	11.06	.14	.12	8.81	19.44
204½	13.75	1.06	.87	11.00	.50	11.50	.16	.16	8.94	19.94
205	14.25	1.50	1.31	11.00	.50	11.50	.19	.16	8.72	19.72
205½	14.31	1.50	1.31	11.00	.50	11.50	.19	.16	8.19	19.19
206	14.31	1.00	.81	10.50	.50	11.00	.22	.16	7.41	17.91
207	14.75	1.12	.94	10.50	.56	11.06	.31	.19	6.56	17.12

FOR DIMENSIONS "B" AND "C", SEE PAGE 8.

FURNISHED WITH EXPOSED BOLTS (EB) WITH SELF-LOCKING NUTS; SHROUDED BOLTS (SB) UPON REQUEST — AT ADDITIONAL COST.

FOR LOAD CAPACITY, USE SERIES F INFORMATION, PAGE 8.

PARALLEL OFFSET CAPACITY SHOULD BE CALCULATED WITH HUB SPACING AT "P" (MIN.), SEE PAGE 39. COMBINED ANGULAR AND PARALLEL OFFSET SHOULD NOT EXCEED $\pm 1/2^\circ$ PER GEAR MESH.

FOR "A" END HUB, MAXIMUM BORE, KEYWAY AND PULLER HOLE DATA, PAGE 40.

TRAVEL (DIMENSION "O") MAY BE DECREASED BY VARYING "P" (CONSULT AMERIDRIVES).

MAXIMUM SPEEDS, PAGE 34.

Series FA, Style I Sizes 201¹/₂-207

Flanged Sleeve —
Single-Engagement Axial Type

Style I

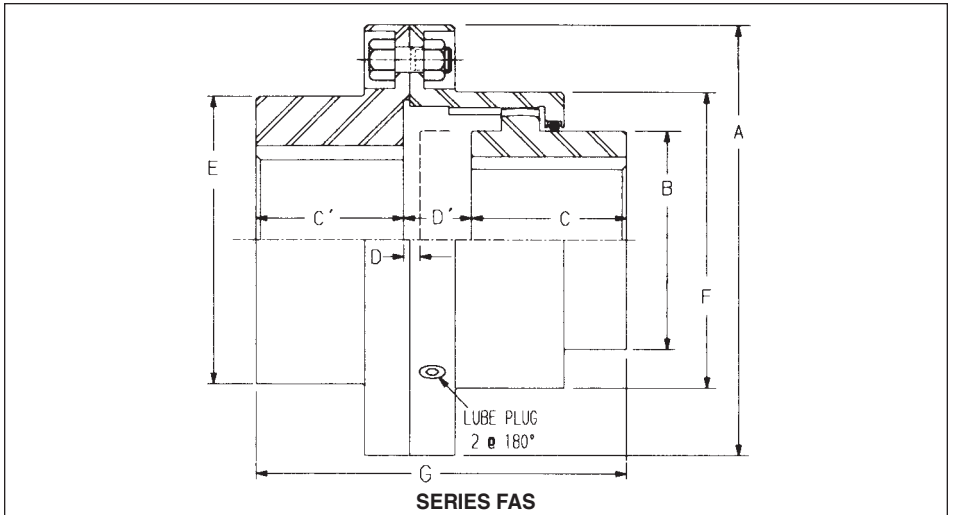
End A

Rigid Half

End B

Universal Hub Modified

Standard Sleeve



FAS STYLE I Size	DIMENSIONS									
	A	B	C	C'	D	D'	E	F	G	Axial Travel
201 ¹ / ₂	6.00	3.12	1.94	1.78	.16	.48	3.92	3.92	4.20	.33
202	7.00	4.00	2.44	2.28	.16	.83	4.86	4.86	5.55	.67
202 ¹ / ₂	8.38	4.88	3.03	2.91	.19	1.11	5.86	5.86	7.05	.92
203	9.44	5.75	3.59	3.41	.19	1.42	6.86	6.86	8.42	1.23
203 ¹ / ₂	11.00	6.50	4.19	3.97	.22	1.69	7.88	7.88	9.84	1.47
204	12.50	7.75	4.75	4.44	.31	2.11	9.22	9.22	11.30	1.80
204 ¹ / ₂	13.62	9.00	5.31	5.00	.34	2.17	10.18	10.35	12.48	1.83
205	15.31	9.50	6.03	5.75	.34	2.64	11.44	11.44	14.42	2.30
205 ¹ / ₂	16.56	10.50	6.62	6.12	.34	3.12	12.69	12.69	15.88	2.78
206	18.00	11.75	7.41	7.16	.41	3.19	13.75	13.75	17.75	2.78
207	20.75	13.50	8.69	8.44	.50	3.44	15.75	16.00	20.56	2.94

SIZES 201¹/₂-205¹/₂ HAVE SHROUDED BOLTS (SB) WITH SELF-LOCKING NUTS; EXPOSED BOLTS (EB) UPON REQUEST — NO ADDITIONAL COST.

SIZES 206 AND 207 HAVE EXPOSED BOLTS (EB) WITH SELF-LOCKING NUTS.

ANGULARITY SHOULD NOT EXCEED $\pm 1/2^\circ$ PER GEAR MESH AT SHAFT SPACING OF "D".

MAXIMUM BORE, KEYWAY AND PULLER HOLE DATA, PAGE 40. CENTER FLANGE DETAILS, PAGE 41.

FOR MAXIMUM BORES AND LOAD CAPACITY, USE SERIES FS INFORMATION, PAGE 10. MAXIMUM SPEEDS, PAGE 34.

Amerigear Flexible Couplings - Fully-Crowned Teeth For Higher Torque, Higher Speed, Higher Misalignment Capacity
All Amerigear Series FAS Couplings incorporate the following engineered features:

- Fully-Crowned Gear Teeth — assures smooth action when adjusting for axial displacement with minimum resistance to slide.
- $\pm 1/2^\circ$ angular misalignment capacity per gear mesh at minimum separation of hub and rigid half. When used in tandem pairs and connected by an intermediate floating shaft, amount of offset misalignment capacity is determined by the distance between gear meshes. By mounting flexible halves on floating shaft, advantage may be taken of larger bore capacity of rigid half. By mounting rigid halves on floating shaft, more parallel offset is available. See page 39 for calculations.
- Accurately machined medium carbon steel hubs and sleeves.
- Positive-type O-ring seals keep lubricant in ... contaminants out. Seals enshrouded to prevent damage.
- Many designs available to accommodate most travel requirements.

Amerigear

Flexible Couplings

Series FAS, Style V Sizes 204-207

Style V

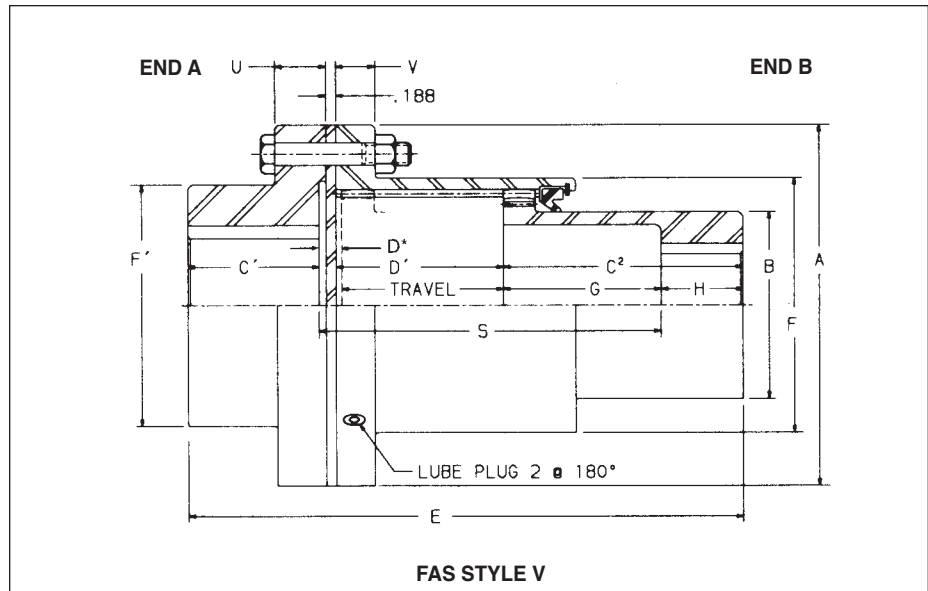
End A

Rigid Half

End B

Special Hub

Long Sleeve with Lip Seal



* SEE PAGE 10 FOR "D" DIMENSION AND ADD .188 FOR PLATE THICKNESS.

FAS Style V Size	FLEX HALF Max. Bore Square Key	Square Key Max. Bore Square Key	DIMENSIONS					
			A	B	C'	C ²	D'	E
204	4.50	6.25	12.50	7.00	4.44	13.50	10.75	29.06
204½	5.50	6.88	13.62	8.38	5.00	13.75	11.16	30.28
205	6.31	6.88	15.31	9.00	5.75	14.25	11.16	31.53
205½	6.88	8.75	16.56	10.00	6.12	14.31	11.16	31.97
206	7.50	9.38	18.00	11.00	7.16	14.31	10.66	32.56
207	9.00	10.75	20.75	13.00	8.44	14.75	10.69	34.38

FAS Style V Size	F	F'	G	H	S	U	V	Axial Travel
204	9.22	9.22	8.75	4.75	19.88	1.06	.88	10.62
204½	10.35	10.18	8.44	5.31	19.97	1.06	.88	11.00
205	11.44	11.44	8.22	6.03	19.75	1.50	1.31	11.00
205½	12.69	12.69	7.69	6.62	19.22	1.50	1.31	11.00
206	13.75	13.75	6.91	7.41	18.00	1.00	.81	10.50
207	16.00	15.75	6.06	8.69	17.25	1.12	.94	10.50

SIZES 204 - 205½ HAVE SHROUDED BOLTS (SB) WITH SELF-LOCKING NUTS; EXPOSED BOLTS (EB) UPON REQUEST — NO ADDITIONAL COST.

SIZES 206 AND 207 HAVE EXPOSED BOLTS (EB) WITH SELF-LOCKING NUTS.

ANGULARITY SHOULD NOT EXCEED $\pm \frac{1}{2}^\circ$ PER GEAR MESH AT SHAFT SPACING OF "D".

FOR LOAD CAPACITY, USE SERIES FS INFORMATION, PAGE 10.

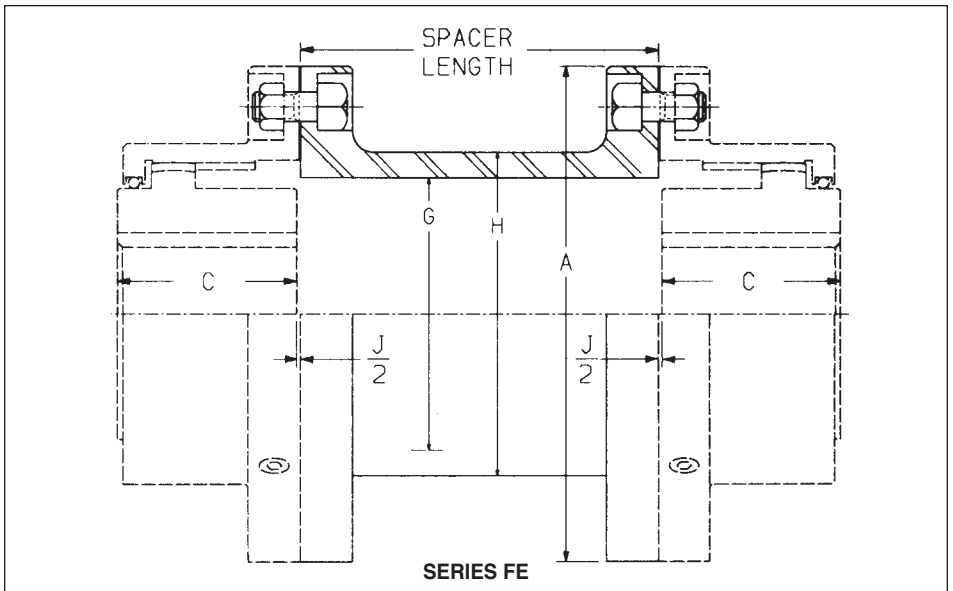
MAXIMUM SPEEDS, PAGE 34.

Series FE Sizes 200-207

Flanged Sleeve – Spacer Type

Application: Commonly used on pump and compressor drives where maintenance or replacement of shaft seals or bearings is accomplished without moving connected equipment. This arrangement is normally used in place of Series FS in tandem arrangements where shaft spacing is minimum and where low weight and WR2 are important.

Description: Amerigear Series FE Flexible Coupling consists of two standard halves assembled to the spacer element. The accurately machined steel spacer may be furnished to desired length. For coupling dimensions, refer to Series F, page 8. See engineering section for speed and torque ratings. Step-down spacers are available for connecting half coupling of different sizes.



FE Size	DIMENSIONS*				Minimum** Spacer Length		Spacer Removal Clearance "J"
	A	C	G	H	SB	EB	
200	2.94	1.06	1.50	1.75	1.00	—	.125
201	3.56	1.38	2.12	2.38	1.00	—	.125
201½	4.00	1.69	2.38	2.75	1.00	—	.125
201½	6.00	1.94	3.23	3.75	2.75	2.75	.125
202	7.00	2.44	4.19	4.81	2.75	3.25	.125
202½	8.38	3.03	5.06	5.66	3.25	4.00	.188
203	9.44	3.59	5.97	6.64	3.25	4.00	.188
203½	11.00	4.19	6.78	7.38	4.12	4.66	.250
204	12.50	4.75	8.06	8.62	4.12	4.66	.250
204½	13.62	5.31	9.36	9.94	4.12	4.66	.313
205	15.31	6.03	9.92	10.75	5.62	5.25	.313
205½	16.56	6.62	10.98	11.75	5.62	5.25	.313
206	18.00	7.41	11.31	12.19	—	4.88	.313
207	20.75	8.69	13.00	13.88	—	5.12	.375

* REFER TO SERIES F COUPLING FOR ADDITIONAL DIMENSIONS, PAGE 8.

** MINIMUM FLANGED SPACER LENGTHS DETERMINED BY REQUIRED BOLT REMOVAL CLEARANCE.

SIZES 200, 201, AND 201¼ FLANGE FASTENERS ARE SELF-LOCKING SOCKET HEAD CAP SCREWS - SPACER FLANGE TAPPED.

SIZES 201½ - 205½ HAVE SHROUDED BOLTS (SB) WITH SELF-LOCKING NUTS; EXPOSED BOLTS (EB) UPON REQUEST - NO ADDITIONAL COST.

SIZES 206 AND 207 HAVE EXPOSED BOLTS (EB) WITH SELF-LOCKING NUTS. SEE PRICE GUIDE FOR STOCK SPACERS.

SEE MODIFICATIONS SECTION FOR VARIATIONS INCLUDING LIMITED END FLOAT, PAGES 23-28.

MAXIMUM SPEEDS, PAGE 36.

PILOT RINGS AVAILABLE AT EXTRA COST. SEE PAGE 41 FOR PILOT RING DIMENSIONS.

Amerigear

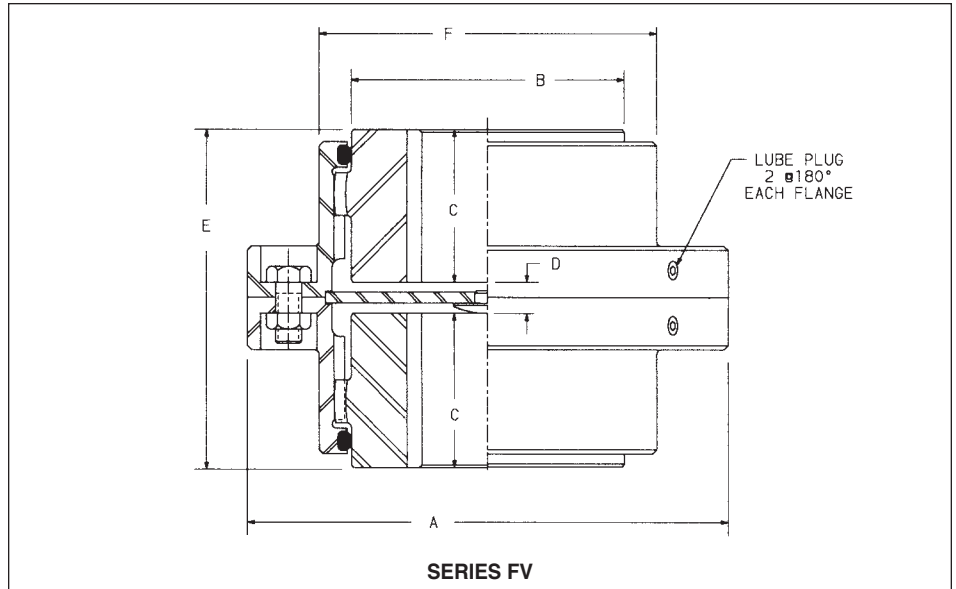
Flexible Couplings

Series FV Sizes 200-207

Flanged Sleeve — Double-Engagement Vertical Type

Application: Meets requirements of vertical shaft applications for shaft sizes up to 10.25" diameter. Compensates for all three types of misalignment.

Description: Amerigear Series FV Flexible Coupling is designed with bolted center flanges to facilitate installation and alignment. The floating sleeve assembly is supported by a plate and thrust button inserted between the coupling sleeves. Optimum separation of gear meshes permits relatively high parallel offset capacity. Flanged sleeve design makes possible minimum distances between bearing housings to facilitate shaft alignment.



FV Size	Maximum Bore - Inches Flexible Shaft		Load Capacity		Parallel Offset Capacity	DIMENSIONS					
	Square Key	Reduced Key	HP Per 100 R.P.M.	Torque In.-Lbs. x10 ³		A	B	C	D	E	F
* 200	.81	.88	3	1.9	.023	2.94	1.25	1.06	.31	2.44	1.94
* 201	1.25	1.31	5	3.2	.042	3.56	1.75	1.38	.31	3.06	2.56
* 201¼	1.63	1.75	12	7.6	.057	4.00	2.25	1.69	.31	3.69	3.00
201½	2.25	2.38	27	17.0	.058	6.00	3.12	1.94	.44	4.31	3.93
202	2.75	2.88	50	31.5	.079	7.00	4.00	2.28	.44	5.00	4.86
202½	3.50	3.75	85	53.6	.102	8.38	4.88	2.84	.56	6.25	5.88
203	4.00	4.25	150	94.5	.119	9.44	5.75	3.41	.56	7.38	6.88
203½	4.50	4.75	225	142.0	.142	11.00	6.50	3.97	.69	8.62	7.90
204	5.50	5.88	340	214.0	.164	12.50	7.75	4.44	.88	9.75	9.24
204½	6.25	6.75	515	324.0	.187	13.62	9.00	4.97	1.00	10.94	10.37
205	6.62	6.75	660	416.0	.218	15.31	9.50	5.69	1.00	12.38	11.44
205½	7.50	7.62	875	551.0	.245	16.56	10.50	6.28	1.00	13.56	12.69
206	8.25	8.62	1,190	750.0	.275	18.00	11.75	7.00	1.12	15.12	13.75
207	9.62	10.25	1,640	1,033.0	.314	20.75	13.50	8.12	1.50	17.75	16.00

* SIZES 200, 201 AND 201¼ FLANGE FASTENERS ARE SELF-LOCKING SOCKET HEAD CAP SCREWS - ONE FLANGE TAPPED.

SIZES 201½ - 205½ HAVE SHROUDED BOLTS (SB) WITH SELF-LOCKING NUTS; EXPOSED BOLTS (EB) UPON REQUEST — NO ADD'L. COST.

SIZES 206 AND 207 HAVE EXPOSED BOLTS (EB) WITH SELF-LOCKING NUTS.

Amerigear Flexible Couplings - Fully-Crowned Teeth For Higher Torque, Higher Speed, Higher Misalignment Capacity
All Amerigear Series FV and FVS Couplings incorporate the following engineered features:

- ± 1½° angular misalignment capacity per gear mesh.
- Torque ratings at full 1½° misalignment,
- Accurately machined medium carbon steel hubs and sleeves.
- Positive-type O-ring seals keep lubricant in ... contaminants out. Seals enshrouded to prevent damage.
- Advanced seal design (Series FV) configuration affords large bore capacity ... permits use of relatively small coupling.

MAXIMUM BORE, KEYWAY AND PULLER HOLE DATA, PAGE 40. CENTER FLANGE DETAILS, PAGE 41. WEIGHTS AND WR², PAGE 38.

ADDITIONAL DETAILS, PAGE 42. MODIFICATIONS AND VARIATIONS, PAGES 23-28. MAXIMUM SPEEDS, PAGE 34.

THRUST BUTTON BEARING PLATE NOT NORMALLY REQUIRED IN LOWER HUB. FOR SHAFT WITH LARGE LATHE CENTERS, SPECIFY BEARING PLATE WHEN ORDERING.

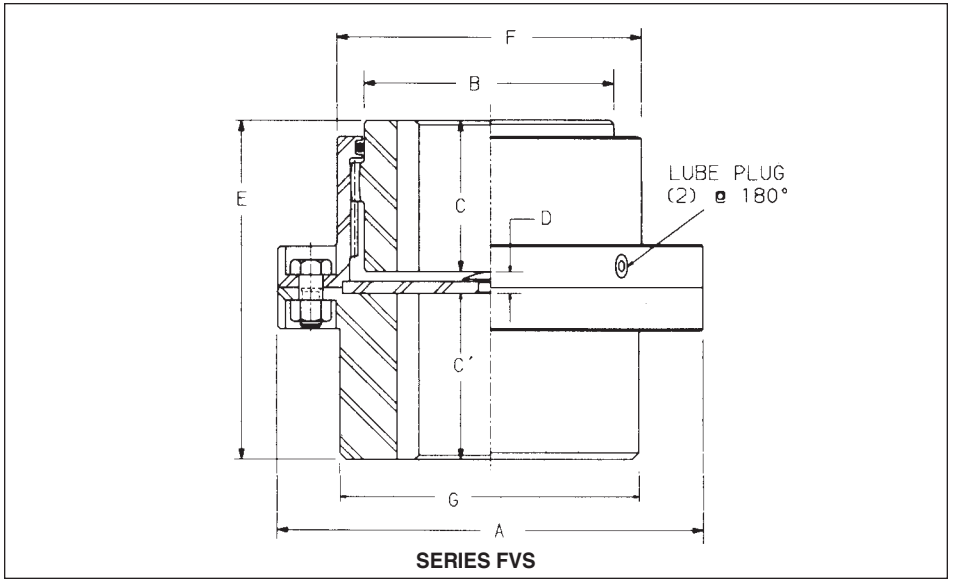
Series FVS Sizes 200-207

Flanged Sleeve –

Single-Engagement Vertical Type

Application: Used primarily in tandem pairs for vertical installation, connected by intermediate floating shaft... or as individual unit in conjunction with a driver or driven shaft having a self-aligning support bearing. When used singly, compensates for angular misalignment only.

Description: Amerigear Series FVS Flexible Coupling consists of one standard rigid half and one standard flexible half coupling modified to accept the thrust button plate. The bolted center flanges facilitate installation and alignment.



FVS Size	Maximum Bore Inches Flexible Half		Maximum Bore Inches Rigid Half		Load Capacity		DIMENSIONS							
	Square Key	Reduced Key	Square Key	Reduced Key	HP Per 100 R.P.M.	Torque In.-Lbs. x10 ³	A	B	C	C'	D	E	F	G
* 200	.81	.88	1.31	1.38	3	1.9	2.94	1.25	1.06	1.05	.25	2.36	1.94	1.94
* 201	1.25	1.31	1.75	1.88	5	3.2	3.56	1.75	1.38	1.23	.25	2.86	2.56	2.56
* 201¼	1.63	1.75	2.00	2.13	12	7.6	4.00	2.25	1.69	1.48	.25	3.42	3.00	3.00
201½	2.25	2.38	2.69	2.88	27	17.0	6.00	3.12	1.94	1.78	.31	4.03	3.92	3.92
202	2.75	2.88	3.25	3.50	50	31.5	7.00	4.00	2.28	2.28	.31	4.88	4.86	4.86
202½	3.50	3.75	4.00	4.25	85	53.6	8.38	4.88	2.84	2.91	.38	6.12	5.86	5.86
203	4.00	4.25	4.62	5.00	150	94.5	9.44	5.75	3.41	3.41	.38	7.19	6.86	6.86
203½	4.50	4.75	5.38	5.75	225	142.0	11.00	6.50	3.97	3.97	.44	8.38	7.88	7.88
204	5.50	5.88	6.25	6.75	340	214.0	12.50	7.75	4.44	4.44	.62	9.50	9.22	9.22
204½	6.25	6.75	6.88	7.38	515	324.0	13.62	9.00	4.97	5.00	.68	10.66	10.35	10.18
205	6.62	6.75	7.88	8.38	660	416.0	15.31	9.50	5.69	5.75	.68	12.12	11.44	11.44
205½	7.50	7.62	8.75	9.25	875	551.0	16.56	10.50	6.28	6.12	.68	13.09	12.69	12.69
206	8.25	8.62	9.38	9.88	1,190	750.0	18.00	11.75	7.00	7.16	.84	15.00	13.75	13.75
207	9.62	10.25	10.75	11.50	1,640	1,033.0	20.75	13.50	8.12	8.44	1.06	17.62	16.00	15.75

*SIZES 200, 201 AND 201¼ FLANGE FASTENERS ARE SELF-LOCKING SOCKET HEAD CAP SCREWS - RIGID FLANGE TAPPED.

SIZES 201½ - 205½ HAVE SHROUDED BOLTS (SB) WITH SELF-LOCKING NUTS; EXPOSED BOLTS (EB) UPON REQUEST — NO ADD'L. COST.

SIZES 206 AND 207 HAVE EXPOSED BOLTS (EB) WITH SELF-LOCKING NUTS.

MAXIMUM BORE, KEYWAY AND PULLER DATA, PAGE 40. CENTER FLANGE DETAILS, PAGE 41. WEIGHTS AND WR², PAGE 38.

THRUST BUTTON BEARING PLATE NOT NORMALLY REQUIRED IN FLEXIBLE HUB. FOR SHAFT WITH LARGE LATHE CENTERS, SPECIFY BEARING PLATE WHEN ORDERING.

ADDITIONAL DETAILS, PAGE 42. MODIFICATIONS AND VARIATIONS, PAGES 23-28.

MAXIMUM SPEEDS, PAGE 34.

Amerigear

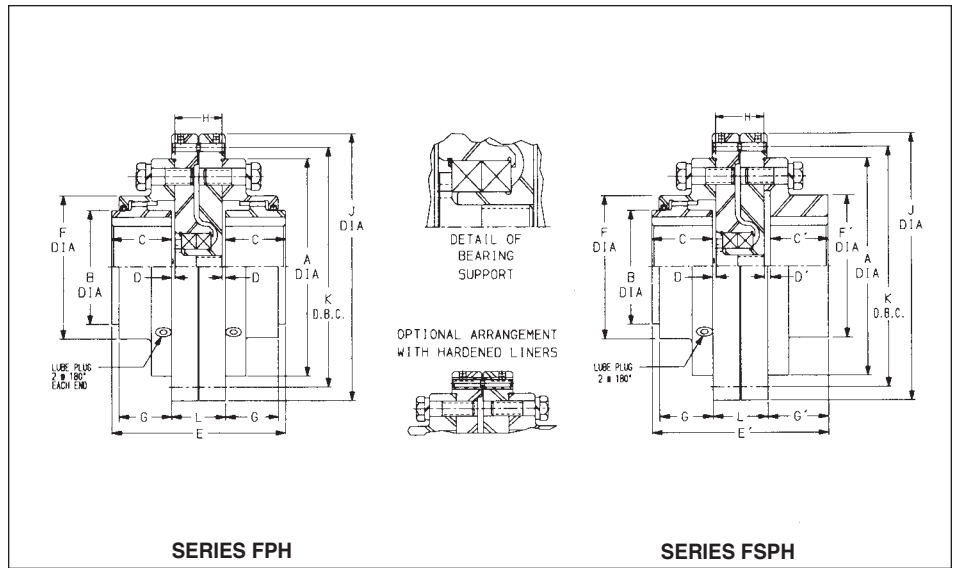
Flexible Couplings

Series FPH, FSPH Sizes 200¹/₂-207

Flanged Sleeve — Double- and Single-Engagement Shear Pin Type

Application: Used for applications where peak torque or high shock load conditions exist and are greater than normal maximum starting torques. Coupling halves are assembled to both or either side of a shear element assembly to accommodate all types of angular misalignment and axial float. Shear pins are designed to fail at a pre-determined value to protect connected equipment from damage.

Description: Amerigear Series FPH and FSPH Shear Pin Couplings have a shear element bolted between the flanges. The shear element consists of two fully machined plates, two lubricated sealed radial thrust ball bearings, retaining ring, retaining bolt and pin, shear pins and setscrews.



FPH, FSPH Size	Maximum Bore		Maximum Bore		Parallel Offset Capacity	Load Capacity		Shear section	
	Square Key	Reduced Key	Square Key	Reduced Key		HP Per 100RPM	Torque In.Lbs. x 10 ³	Weight Lbs.	WR ² Lb.-In. ²
201 ¹ / ₂	2.25	2.38	2.69	2.88	.097	27	17.0	18	119
202	2.75	2.88	3.25	3.50	.118	50	31.5	20	192
202 ¹ / ₂	3.50	3.75	4.00	4.25	.142	85	53.6	27	354
203	4.00	4.25	4.62	5.00	.182	150	94.5	68	1,302
203 ¹ / ₂	4.50	4.75	5.38	5.75	.205	225	142.0	88	2,113
204	5.50	5.88	6.25	6.75	.226	340	214.0	109	3,220
204 ¹ / ₂	6.25	6.75	6.88	7.38	.250	515	324.0	116	3,904
205	6.62	6.75	7.88	8.38	.298	660	416.0	205	9,402
205 ¹ / ₂	7.50	7.62	8.75	9.25	.326	875	551.0	232	12,190
206	8.25	8.62	9.38	9.88	.355	1,190	750.0	271	16,126
207	9.62	10.25	10.75	11.50	.394	1,640	1,033.0	—	—

FPH, FSPH Size	DIMENSIONS															
	A	B	C	C'	D	D'	E	E'	F	F	G	G	H	J	K	L
201 ¹ / ₂	6.00	3.12	1.94	1.78	.06	.09	5.50	5.38	3.92	3.92	1.77	1.88	1.50	7.38	6.625	1.59
202	7.00	4.00	2.44	2.28	.06	.09	6.50	6.38	4.86	4.86	2.27	2.38	1.50	8.38	7.625	1.59
202 ¹ / ₂	8.38	4.88	3.03	2.91	.09	.09	7.75	7.62	5.86	5.86	2.81	3.00	1.50	9.75	9.000	1.59
203	9.44	5.75	3.59	3.41	.09	.09	9.75	9.56	6.86	6.86	3.39	3.50	2.38	11.94	10.438	2.50
203 ¹ / ₂	11.00	6.50	4.19	3.97	.12	.09	11.00	10.75	7.88	7.88	3.91	4.06	2.38	13.50	12.000	2.50
204	12.50	7.75	4.75	4.44	.12	.19	12.12	11.88	9.22	9.22	4.46	4.62	2.38	15.00	13.500	2.50
204 ¹ / ₂	13.62	9.00	5.31	5.00	.16	.19	13.31	13.03	10.35	10.18	4.98	5.19	2.38	16.12	14.625	2.50
205	15.31	9.50	6.03	5.75	.16	.19	15.44	15.19	11.44	11.44	5.67	5.94	3.06	18.31	16.562	3.31
205 ¹ / ₂	16.56	10.50	6.62	6.12	.16	.19	16.62	16.16	12.69	12.69	6.25	6.31	3.06	19.56	17.812	3.31
206	18.00	11.75	7.41	7.16	.16	.25	18.19	18.03	13.75	13.75	6.89	7.41	3.06	21.00	19.250	3.31
207	20.75	13.50	6.69	8.44	.19	.31	20.81	20.69	16.00	15.75	7.81	8.75	3.06	23.75	22.000	3.66

EXPOSED BOLTS ARE FURNISHED AS STANDARD.
MAXIMUM BORE, KEYWAY AND PULLER HOLE DATA, PAGE 40. CENTER FLANGE DETAILS, PAGE 41. MAXIMUM SPEEDS, PAGE 34.

Modifications and Variations Series F

An extensive stock of standard coupling components and inventory of bar and tube, allows for the design and manufacture of couplings to a variety of specific customer requirements. On this and the next few pages is data referring to some of the coupling modifications and/or alterations that are available in the Series F design, and on pages 31-33 for the Series C design.

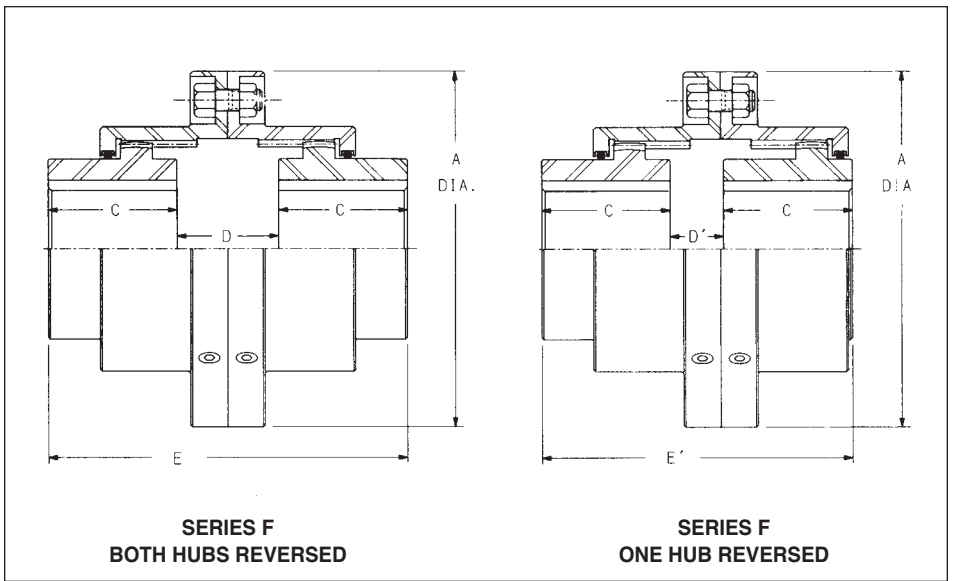
Reverse Mounted Hubs — Series F

Application: Used where greater-than-standard shaft separation is required to allow insertion of pulleys and similar components through shaft separation without moving connected equipment. Accomplished without spacer or adaptor plate.

Description: All standard components used. Hubs (or hub) simply mounted on shafts in reverse position. If hub puller holes desired, specify when ordering.

CAUTION:

This configuration is not intended for use in applications requiring axial travel. Dimension D in Series F Couplings must be maintained.



SERIES F, REVERSE MOUNTED HUBS

Size	Maximum Bore - Inches		Load Capacity		DIMENSIONS					
	Square Key	Reduced Key	HP Per 100 R.P.M.	Torque In.-Lbs. x10 ³	A	C	D	D'	E	E'
200	.81	.88	3	1.9	2.94	1.06	—	—	—	—
201	1.25	1.31	5	3.2	3.56	1.38	.31	.22	3.06	2.98
201 ¹ / ₄	1.62	1.75	12	7.6	4.00	1.69	.88	.50	4.25	3.88
201 ¹ / ₂	2.25	2.38	27	17.0	6.00	1.94	.44	.28	4.31	4.16
202	2.75	2.88	50	31.5	7.00	2.44	1.00	.56	5.88	5.44
202 ¹ / ₂	3.50	3.75	85	53.6	8.38	3.03	1.56	.88	7.62	6.94
203	4.00	4.25	150	94.5	9.44	3.59	1.75	.97	8.94	8.16
203 ¹ / ₂	4.50	4.75	225	142.0	11.00	4.19	2.25	1.25	10.62	9.62
204	5.50	5.88	340	214.0	12.50	4.75	2.75	1.50	12.25	11.00
204 ¹ / ₂	6.25	6.75	515	324.0	13.62	5.31	3.38	1.84	14.00	12.47
205	6.62	6.75	660	416.0	15.31	6.03	4.31	2.31	16.38	14.38
205 ¹ / ₂	7.50	7.62	875	551.0	16.56	6.62	5.19	2.75	18.44	16.00
206	8.25	8.62	1,190	750.0	18.00	7.41	5.88	3.09	20.69	17.91
207	9.62	10.25	1,640	1,033.0	20.75	8.69	6.25	3.31	23.62	20.69

REFER TO SERIES F COUPLING, PAGES 8 AND 42 FOR ADDITIONAL DIMENSIONS. FLANGE DETAILS, PAGE 41. MAXIMUM BORE, KEYWAY AND PULLER HOLE DATA, PAGE 40.

Amerigear

Flexible Couplings

Modifications and Variations

Series F

Tandem Assemblies Two FS Series Couplings connected by an intermediate floating shaft comprise a tandem assembly. The amount of offset capacity is determined by the distance between gear meshes. By mounting flexible halves on floating shaft, advantage may be taken of larger bore capacity of rigid half (Fig. A). By mounting rigid halves on floating shaft, more parallel offset capacity is available (Fig. B). Tandems may also be used in vertical applications (Fig. C) with additional modifications.

See Page 37 for maximum operating speeds of tandem couplings.

Size	Shaft Dia.	Size	Shaft Dia.
200	.88	203½	4.00
201	1.25	204	5.00
201¼	1.62	204½	6.00
201½	2.00	205	6.00
202	2.50	205½	6.50
202½	3.00	206	8.00
203	3.50	207	8.00

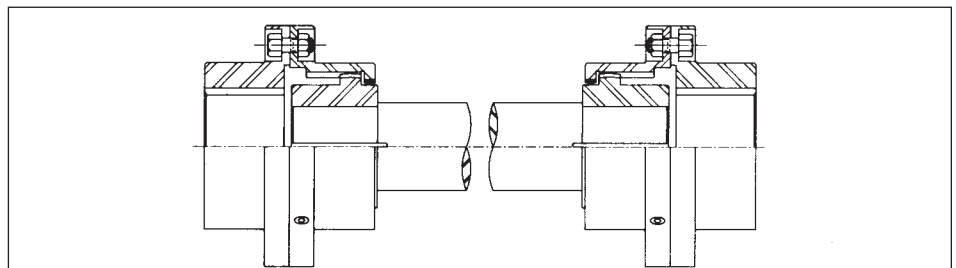


FIG. A TANDEM - FLEXIBLE HALVES ON FLOATING SHAFT

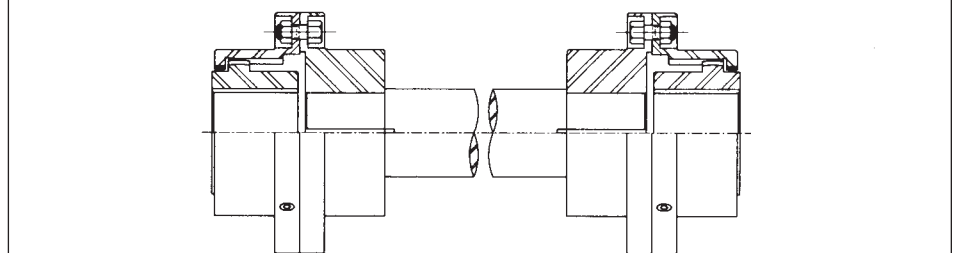
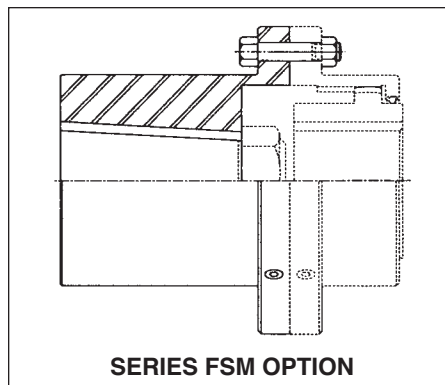


FIG. B TANDEM - RIGID HALVES ON FLOATING SHAFT



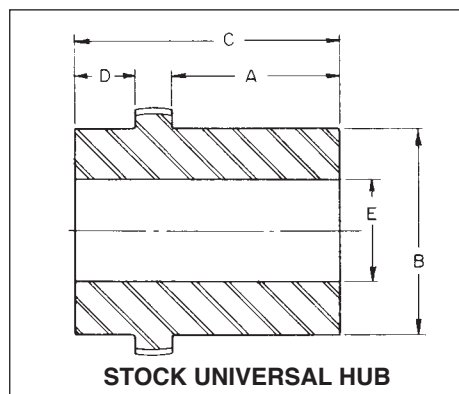
SERIES FSM OPTION

Single Engagement Mill Motor Type With Taper Bore In Rigid Half

Specially-designed Series FSM with Taper Bore in rigid half are used to accommodate larger shaft sizes with a minimum-sized flexible coupling.

Stock Universal Hubs Ameridrives International, provides a wide variety of Universal Hubs to minimize lead time and reduce order and delivery costs on nonstandard specifications requiring longer-than-standard hub lengths.

Universal Hub Size	A	B	C	D	Rough Stock Bore E
201½	3.31	3.12	4.34	.50	.750
202	4.00	4.00	5.38	.75	1.000
202½	4.38	4.88	6.38	1.25	1.000
203	4.50	5.75	6.88	1.50	1.500
203½	5.00	6.50	7.50	1.50	1.500
204	5.81	7.75	8.31	1.38	2.375
204½	5.50	9.00	8.75	2.00	2.375
205	5.50	9.50	9.25	2.38	3.375
205½	6.50	10.50	10.88	2.88	3.375
206	8.50	11.75	13.12	3.00	3.375



STOCK UNIVERSAL HUB

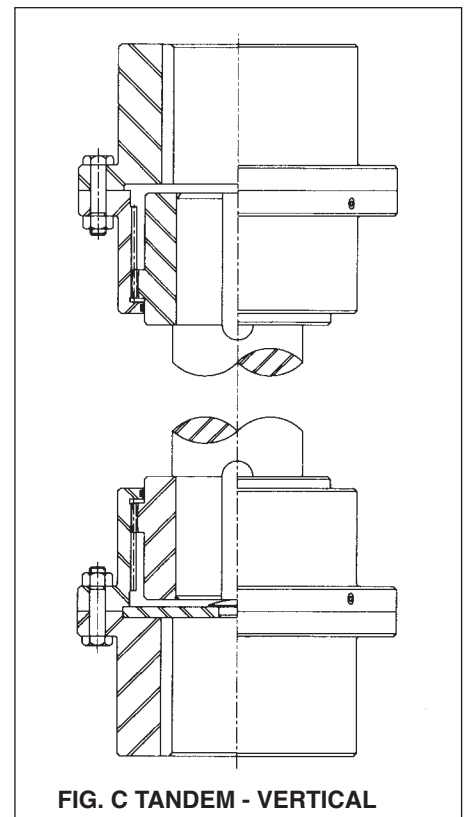


FIG. C TANDEM - VERTICAL

Modifications and Variations

Series F

Limited End-Float Variation

Application: Recommended for installations where axial travel must be limited to a lesser degree than inherent in standard flexible couplings, such as in a sleeve bearing motor to prevent the rotor from “wiping” the bearing shoulders.

Description: A standard coupling is designed with clearances to accommodate misalignment and manufacturing tolerances. When an application requires that the end float be restrained, a plastic disc is positioned between the faces of coupling hubs.

In the case of spacer arrangements, steel plates with steel thrust buttons are fitted to the spacer.

As shown, the tandem design can be modified for limited end float.

It should be noted that as the coupling is extended or compressed for LEF, the misalignment capacity of the coupling is reduced accordingly.

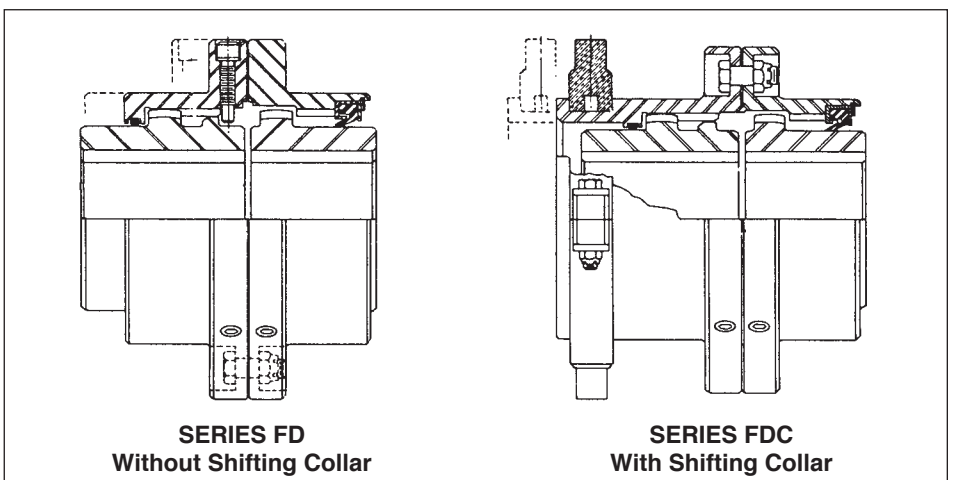
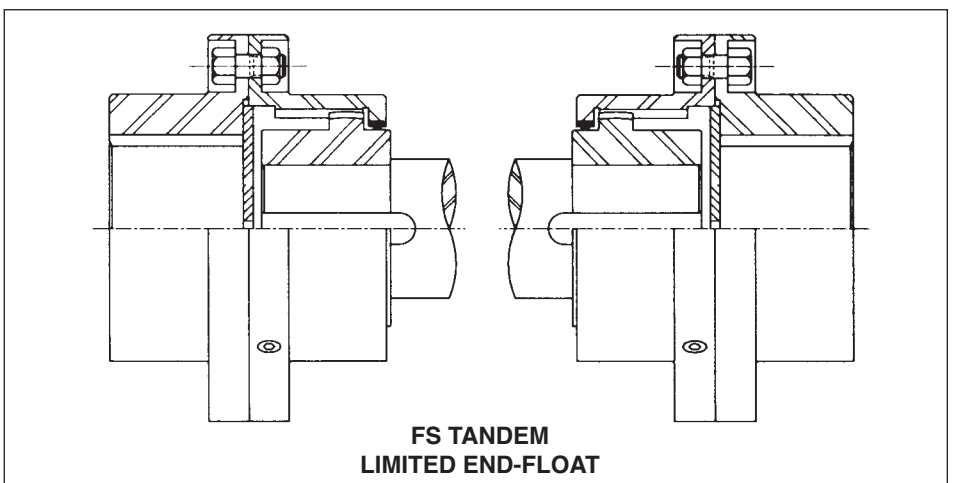
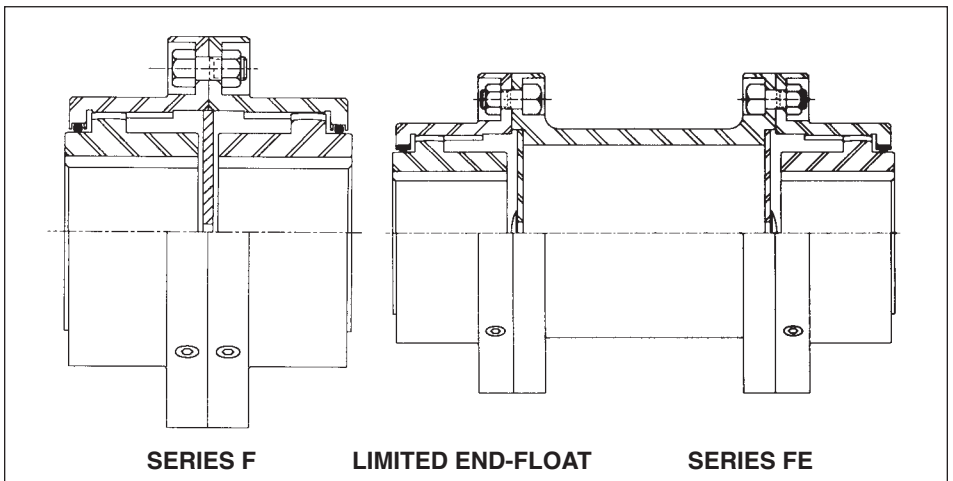
Flanged Sleeve –

Double Engagement Disconnect Type

Application: Meets requirements for quick connection or disconnection of shafts up to 9” diameter, as in stand-by or emergency mechanical power transmission service. Compensates for all three types of misalignment.

Description: Amerigear Series FD and FDC Flexible Couplings are designed with bolted center flanges to facilitate installation and alignment. Flanged-sleeve design makes possible minimum distances between bearing housings to facilitate shaft alignment.

Note: The right-hand hub or disengaging hub is to be mounted on the driving shaft. Chamfered entry teeth provided on disengaging hub and sleeve only when specified – at additional cost.



Amerigear

Flexible Couplings

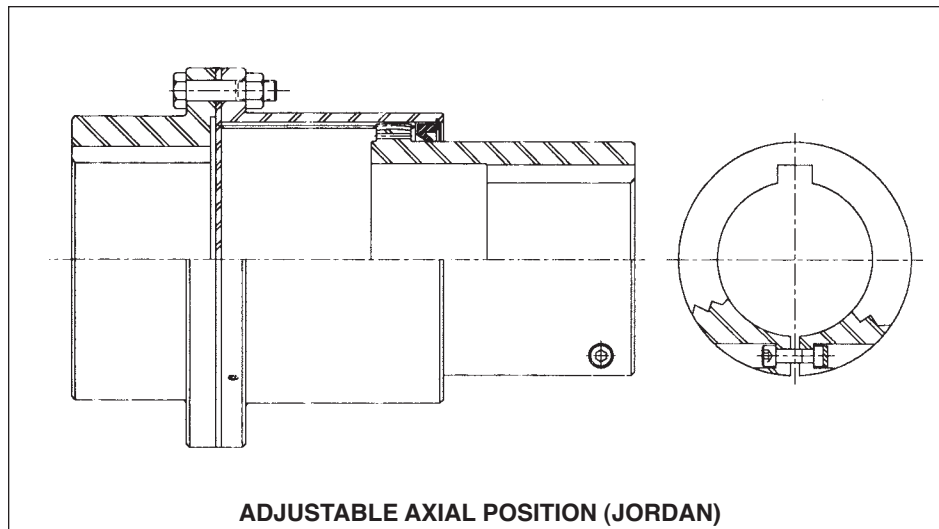
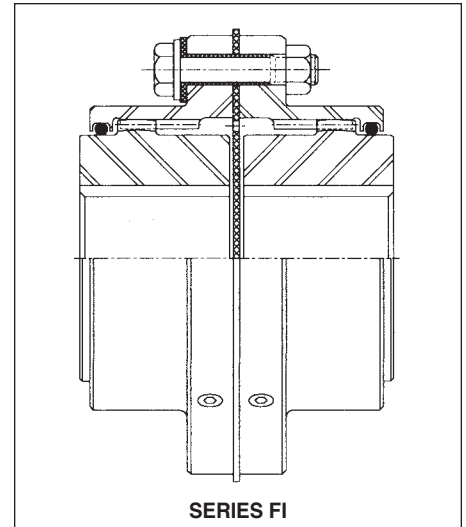
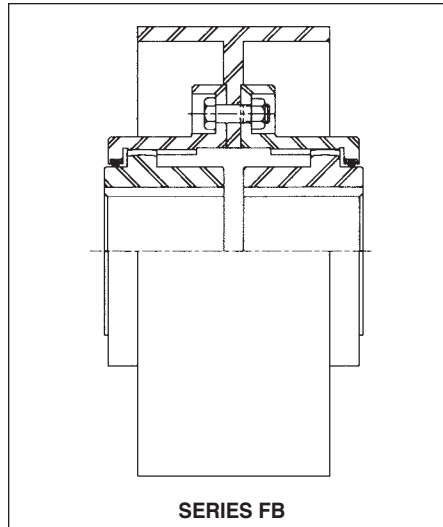
Modifications and Variations

Series F

Brake Drum Series FB Coupling

Application: The FB coupling is designed for use in applications that require a brake drum but have insufficient space between the driver and the driven components for a separate brake drum mounting.

Description: The FB coupling consists of standard Amerigear Series F sleeves and hubs with a flange type brake drum bolted securely between the sleeve flanges. Depending on the diameter of the drum, the drum may be machined as one piece or fabricated. When ordering, specify drum diameter and face width.



Adjustable Axial Position Coupling

Application: In certain types of equipment drives, shaft-to-shaft distance varies during equipment operation requiring an axial travel type of coupling. In addition, adjustment to maintain the maximum axial travel for various initial shaft-to-shaft conditions is also required. The design of the adjustable axial positioning coupling suits this purpose.

Description: The coupling design is similar to that of the axial travel FA or FAS Series. The exception is that the hub of the travel half of the coupling is fitted with a clamp bolt design. The clamp bolt holds the coupling hub in position. When adjustment is necessary, after the drive has stopped rotating, the clamp bolt is loosened and the hub is slid along the equipment shaft to the new position. The clamp bolt is then retightened. This is performed without having to move either the driver or the driven components of the equipment.

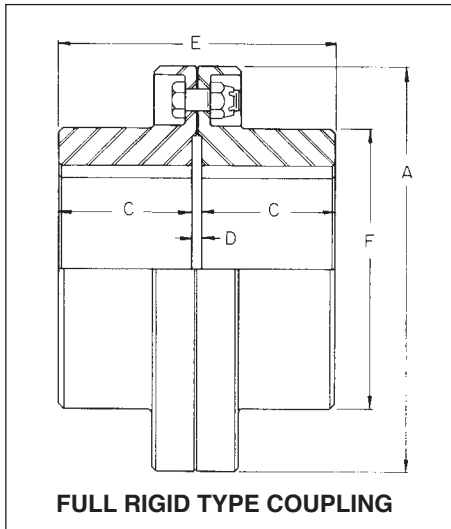
Insulated Type Series FI Coupling

Application: The FI coupling is designed for use when driver and driven equipment must be electrically insulated from each other to prevent the flow of stray electrical currents. The FI protects against the pitting of precision bearings and shafts that may occur in equipment such as generator excitor drives.

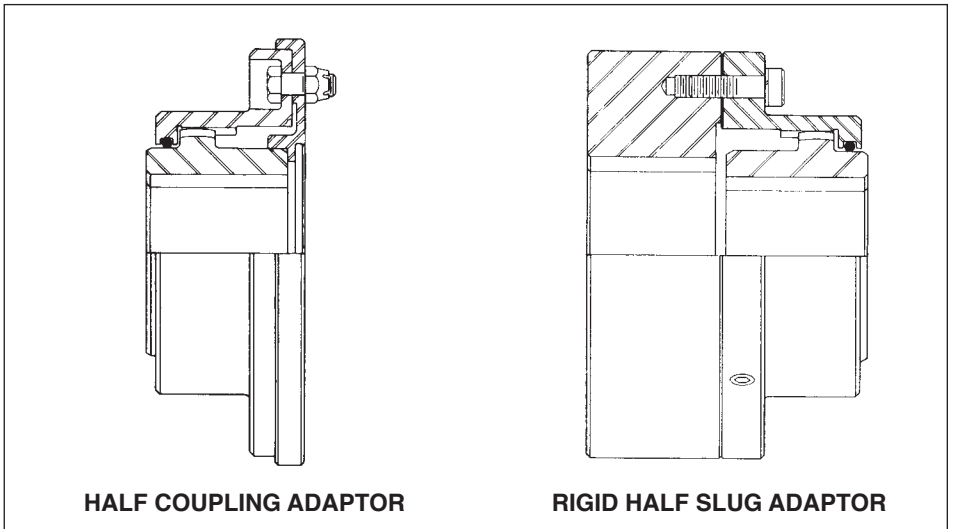
Description: The Amerigear Series FI coupling incorporates an insulator washer, insulated bolts and an insulator disc to isolate the two halves of the coupling.

Compared to the Amerigear Saeries F coupling, the FI coupling shaft-to-shaft is increased and misalignment capacity is limited to $\pm 3/4^\circ$ per gear mesh.

Modifications and Variations Series F



FULL RIGID TYPE COUPLING



HALF COUPLING ADAPTOR

RIGID HALF SLUG ADAPTOR

Full Rigid Type Coupling

Application: For mechanical power transmission applications where no misalignment or axial displacement exists between connected shafts.

Description: Accurately-machined medium carbon steel.

Full Rigid Size	A	C	D	E	F
200	2.94	1.05	—	2.09	1.94
201	3.56	1.23	—	2.47	2.56
201¼	4.00	1.48	—	2.97	3.00
201½	6.00	1.78	.19	3.75	3.88
202	7.00	2.28	.19	4.75	4.88
202½	8.38	2.91	.19	6.00	5.75
203	9.44	3.41	.19	7.00	6.81
203½	11.00	3.97	.19	8.12	7.75
204	12.50	4.44	.38	9.25	9.06
204½	13.62	5.00	.38	10.38	10.19
205	15.31	5.75	.38	11.88	11.38
205½	16.56	6.12	.38	12.62	12.50
206	18.00	7.16	.50	14.81	13.50
207	20.75	8.44	.62	17.50	15.75

SIZES 200, 201 AND 201¼ FLANGE FASTENERS ARE SELF-LOCKING SOCKET HEAD CAP SCREWS – ONE FLANGE TAPPED.

SIZES 201½-205½ HAVE SHROUDED BOLTS (SB) WITH SELF-LOCKING NUTS; EXPOSED BOLTS (EB) UPON REQUEST – NO ADDITIONAL COST.

SIZES 206 AND 207 HAVE EXPOSED BOLTS (EB) WITH SELF-LOCKING NUTS.

Half Coupling Adaptors Adaptors are used where one of the connected machines is disconnected, leaving the other machine in service; or where individual equipment testing is required.

Adaptor ring is secured to sleeve and pilots the hub, holding sleeve concentric and rigid with the hub.

On close-coupled installations, adaptors are usually segmented or split for ease of installation. On spacer couplings, the adaptor is a solid, one-piece construction.

Rigid Half Slug Adaptor For tandem arrangements where one shaft is considerably larger than the other. Utilizes standard Series F – flexible half mounted to a special slug adaptor. Bore length and O.D. same as dimension C and A listed to the left for full rigid type couplings.

Differential Tooth Coupling (Modification) Series F Only

Application: For accurate adjustment and control of angular shaft relationships as required on press drives, feed mechanisms, timing devices and similar applications.

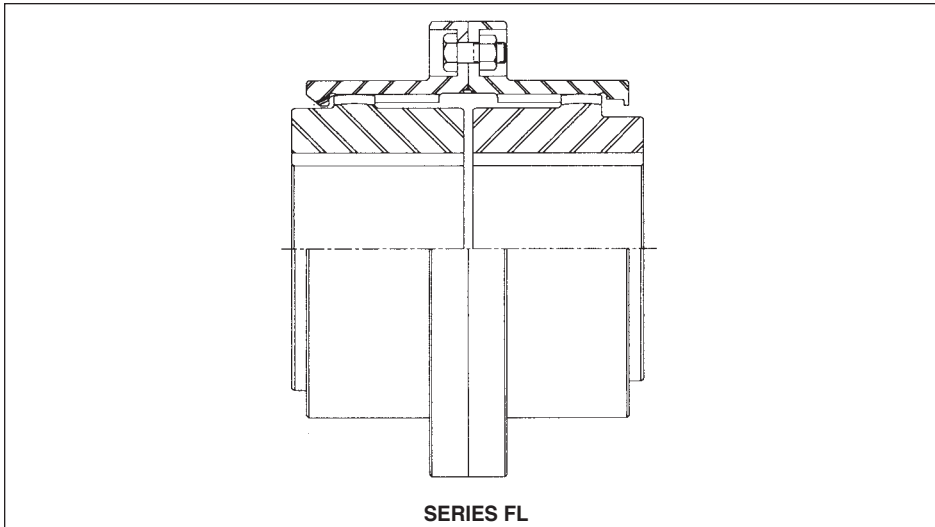
Description: One half of Amerigear Series F (Modified) Flexible Coupling is a standard half Series F Coupling. Other half contains a special hub and sleeve designed with one tooth more or less than standard mating half. This permits vernier adjustment of shaft-to-shaft or sleeve-to-sleeve relationship for desired shaft synchronization.

Amerigear

Flexible Couplings

Modifications and Variations

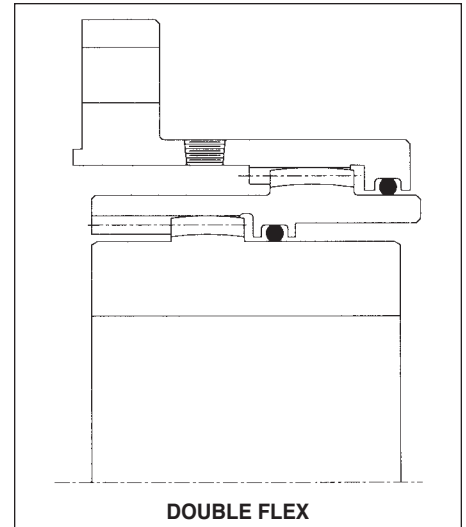
Series F



Continuously-Lubricated Type Coupling

Application: Continuous oil lubrication is desirable under certain conditions of high ambient operating temperatures. Since this design does not utilize the contaminant-proof features of standard couplings, the installation should be enclosed to prevent the entrance of excessive dust or moisture, and should be provided with an adequate flow of clear oil. Lubricating oil should be filtered to at least 5 microns and the location of the oil nozzles should be positioned as close as possible to the coupling in order to minimize oil jet deflection due to windage. Type of lubricant should be chosen carefully, with consideration given to load carrying characteristics. Quantity of flow depends on horsepower transmitted, and this flow requirement will be specified by Ameridrives International.

Description: Amerigear Series FL Flexible Couplings utilize standard components with sleeves modified for oil inlet and discharge. Differential level of location of inlet and discharge openings assure positive lubricant flow. Design provides for retention of oil in event of pump failure, or for intermittent type lubrication. Angled discharge holes assure scavenging action to minimize sludge accumulation.



Double Flex Coupling

Application: The double flex coupling is designed for applications that are limited in space between driver and driven equipment. The double flex design accommodates both angular and offset misalignment in a compact design.

Description: Similar to the Amerigear standard coupling, the double flex coupling has a sleeve and a hub. The main difference is that a gear ring is positioned between the hub and sleeve. The gear ring has an external gear to mate with the sleeve internal gear and an internal gear to fit the hub external gear.

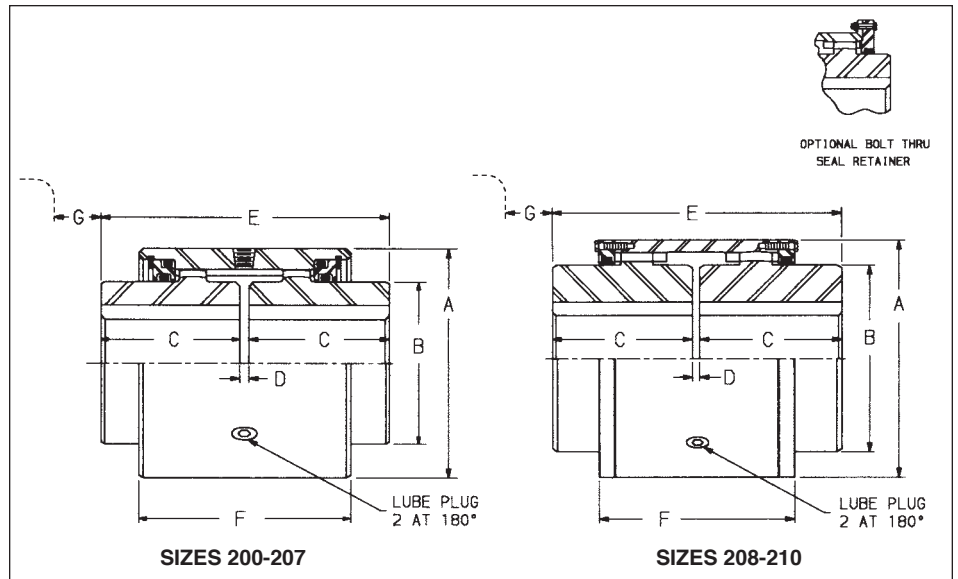
Series C

Sizes 200-210

Continuous Sleeve — Double-Engagement Type

Application: Amerigear Series C offers the advantages of lower initial cost, higher speeds, greater safety, more compactness and extremely low weight and WR². Compensates for all three types of misalignment. Meets requirements of all standard applications for shaft sizes up to 15" diameter.

Description: Amerigear Series C Flexible Coupling is designed with a smooth, cylindrical one-piece sleeve for smoother, faster, quieter and safer operation. Positive-engagement steel snap rings keep coupling constrained during operation under the most adverse conditions of axial end loading ... permits quicker assembly and disassembly. Lower cost over comparably rated flange-and-bolt types.



C Size	Maximum Bore - Inches		Load Capacity		Parallel Offset Capacity In.	DIMENSIONS						
	Square Key	Reduced Key	HP Per 100 R.P.M.	Torque In.-Lbs. x 10 ³		A	B	C	D	E	F	G**
*200	.81	.88	3	1.9	.023	2.12	1.25	1.06	.12	2.25	2.25	1.31
*201	1.25	1.31	5	3.2	.037	2.69	1.75	1.38	.12	2.88	2.88	1.62
201¼	1.63	1.75	12	7.6	.038	3.19	2.25	1.69	.12	3.50	2.94	1.38
201½	2.25	2.38	27	17.0	.050	4.38	3.12	1.94	.12	4.00	3.56	1.90
202	2.75	2.88	50	31.5	.056	5.38	4.00	2.44	.12	5.00	4.06	1.90
202½	3.50	3.75	85	53.6	.056	6.50	4.88	3.03	.19	6.25	4.63	1.90
203	4.00	4.25	150	94.5	.078	7.44	5.75	3.59	.19	7.37	5.59	2.30
203½	4.50	4.75	225	142.0	.090	8.32	6.50	4.19	.25	8.63	6.43	2.50
204	5.50	5.88	340	214.0	.098	9.86	7.75	4.75	.25	9.75	7.06	2.67
204½	6.25	6.75	515	324.0	.107	10.88	9.00	5.31	.31	10.93	7.58	2.63
205	6.62	6.75	660	416.0	.114	11.75	9.50	6.03	.31	12.37	8.01	2.34
205½	7.50	7.62	875	551.0	.117	12.75	10.50	6.62	.31	13.55	8.28	2.01
206	8.25	8.62	1,190	750.0	.129	14.00	11.75	7.41	.31	15.13	8.91	1.86
207	9.62	10.25	1,640	1,033.0	.160	16.38	13.50	8.69	.38	17.76	10.44	2.11
208	11.25	12.25	2,380	1,500.0	.101	18.38	15.62	9.75	.38	19.88	11.88	1.77
209	12.25	13.38	2,700	1,700.0	.114	20.50	17.50	10.75	.50	22.00	13.25	2.15
210	13.75	15.00	3,300	2,080.0	.127	22.38	19.00	12.00	.50	24.50	14.38	2.01

FOR LARGER SIZES, CONTACT AMERIDRIVES INTERNATIONAL.

*SIZES 200 AND 201 FURNISHED WITHOUT LUBE PLUGS.

**CLEARANCE FOR ALIGNING COUPLING.

MAXIMUM BORE, KEYWAY AND PULLER HOLE DATA, PAGES 9 AND 40. ADDITIONAL DETAILS, PAGES 42-43. MODIFICATIONS AND VARIATIONS, PAGES 31-33.

MAXIMUM SPEEDS, PAGE 34. WEIGHTS AND WR², PAGES 38-39.

Amerigear Flexible Couplings - Fully-Crowned Teeth For Higher Torque, Higher Speed, Higher Misalignment Capacity

All Amerigear Series C Couplings incorporate the following engineered features:

- Sizes 200-207, ± 1½° angular misalignment capacity per gear mesh.
- Sizes 208-210, ± ¾° angular misalignment capacity per gear mesh.
- Torque ratings at full angular misalignment,
- Accurately machined medium carbon steel hubs and sleeves.
- Positive-type O-ring seals keep lubricant in ... contaminants out. Seals enshrouded to prevent damage.

Amerigear

Flexible Couplings

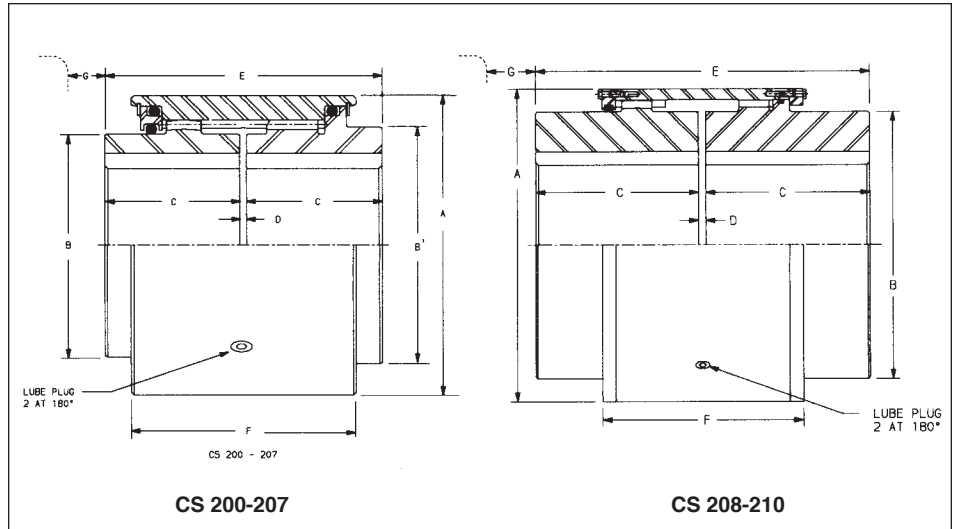
Series CS

Sizes 200-210

Continuous Sleeve – Single-Engagement Type

Application: Meets the application requirements described for Amerigear Series FS Couplings (page 10), but in addition offers the advantages of greater safety, more compactness and extremely low weight and WR^2 .

Description: Amerigear Series CS Flexible Coupling is designed with a smooth, cylindrical one-piece sleeve for smoother, faster, quieter and safer operation. Rigid half is splined. Positive-engagement steel snap rings keep the flexible half and rigid half constrained during operation under the most adverse conditions of axial end loadings ... permits quicker assembly and disassembly.



CS Size	Maximum Bore Inches Flexible Half		Maximum Bore Inches Rigid Half		Load Capacity		DIMENSIONS							
	Square Key	Reduced Key	Square Key	Reduced Key	HP Per 100 R.P.M.	Torque In.-Lbs. x 10 ³	A	B	B'	C	D	E	F	G**
*200	.81	.88	.88	1.00	3	1.9	2.12	1.25	1.25	1.06	.12	2.25	2.25	1.31
*201	1.25	1.31	1.31	1.38	5	3.2	2.69	1.75	1.75	1.38	.12	2.88	2.88	1.62
201¼	1.62	1.75	1.62	1.75	12	7.6	3.19	2.25	2.25	1.69	.12	3.50	2.94	1.38
201½	2.25	2.38	2.25	2.38	27	17.0	4.38	3.12	3.50	1.94	.12	4.00	3.56	1.90
202	2.75	2.88	2.75	3.00	50	31.5	5.38	4.00	4.25	2.44	.12	5.00	4.06	1.90
202½	3.50	3.75	3.50	3.75	85	53.6	6.50	4.88	5.25	3.03	.19	6.25	4.63	1.90
203	4.00	4.25	4.00	4.25	150	94.5	7.44	5.75	6.12	3.59	.19	7.37	5.59	2.30
203½	4.50	4.75	4.50	4.88	225	142.0	8.32	6.50	6.81	4.19	.25	8.63	6.43	2.50
204	5.50	5.88	5.50	5.88	340	214.0	9.86	7.75	8.00	4.75	.25	9.75	7.06	2.67
204½	6.25	6.75	6.25	6.75	515	324.0	10.88	9.00	9.25	5.31	.31	10.93	7.58	2.63
205	6.62	6.75	7.00	7.12	660	416.0	11.75	9.50	10.00	6.03	.31	12.37	8.28	2.34
205½	7.50	7.62	7.50	8.00	875	551.0	12.75	10.50	11.00	6.62	.31	13.55	8.91	2.01
206	8.25	8.62	8.25	8.62	1,190	750.0	14.00	11.75	12.00	7.41	.31	15.13	10.44	1.86
207	9.62	10.25	9.62	10.25	1,640	1,033.0	16.38	13.50	13.75	8.69	.38	17.76	16.00	2.11
208	11.25	12.25	11.25	12.25	2,380	1,500.0	18.38	15.62	15.62	9.75	.38	19.88	11.88	1.77
209	12.25	13.38	12.25	13.38	2,700	1,700.0	20.50	17.50	17.50	10.75	.50	22.00	13.25	2.15
210	13.75	15.00	13.75	15.00	3,300	2,080.0	22.38	19.00	19.00	12.00	.50	24.50	14.38	2.00

FOR LARGER SIZES, CONTACT AMERIDRIVES INTERNATIONAL.

*SIZES 200 AND 201 FURNISHED WITHOUT LUBE PLUGS.

**CLEARANCE FOR ALIGNING COUPLING.

MAXIMUM BORE, KEYWAY AND PULLER HOLE DATA, PAGE 40.

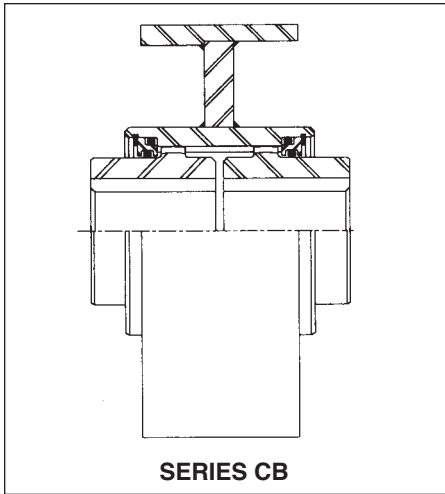
ADDITIONAL DIMENSIONS, PAGES 42-43. MODIFICATIONS AND VARIATIONS, PAGES 31-33. MAXIMUM SPEEDS, PAGE 34.

Amerigear Flexible Couplings - Fully-Crowned Teeth For Higher Torque, Higher Speed, Higher Misalignment Capacity
All Amerigear Series CS Couplings incorporate the following engineered features:

- Sizes 200-207, $\pm 1\frac{1}{2}^\circ$ angular misalignment capacity.
- Sizes 208-210, $\pm \frac{3}{4}^\circ$ angular misalignment capacity.
- Torque ratings at full misalignment.
- Accurately machined medium carbon steel hubs and sleeves.
- Positive-type O-ring seals keep lubricant in ... contaminants out. Seals enshrouded to prevent damage.

Modifications and Variations

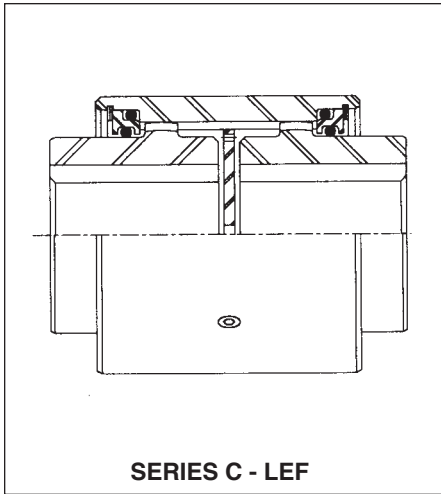
Series C



Brake Drum Type Coupling

Application: The Series CB Brake Drum Coupling is used where the shaft space prevents a separate drum mounting and the drum diameter prevents a bolted design to be used.

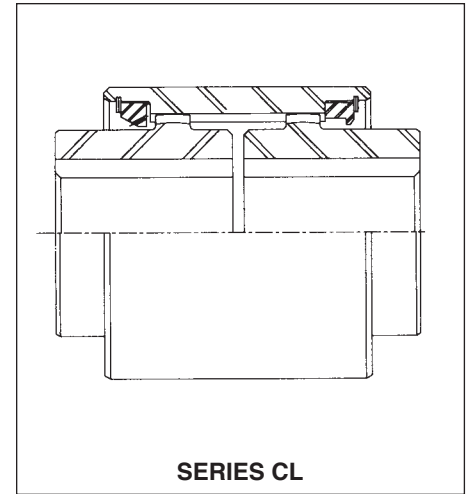
Description: The Series CB Brake Drum is integral with the coupling sleeve. It may be fabricated or totally machined. When ordering, specify the drum outer diameter and the face width.



Limited End Float Coupling

Application: The standard Series C coupling is designed with clearances to accommodate misalignment and manufacturing tolerances. When the application requires that the end float be restrained, a plastic disc is positioned between the faces of the coupling hubs.

It should be noted that as the coupling is extended or compressed for LEF, the misalignment capacity of the coupling is reduced accordingly.



Continuously Lubricated Coupling

Application: The C Series coupling can be modified for continuous oil lubrication. The same oil supply qualifications listed under the FL Amerigear also apply to the CL Series couplings.

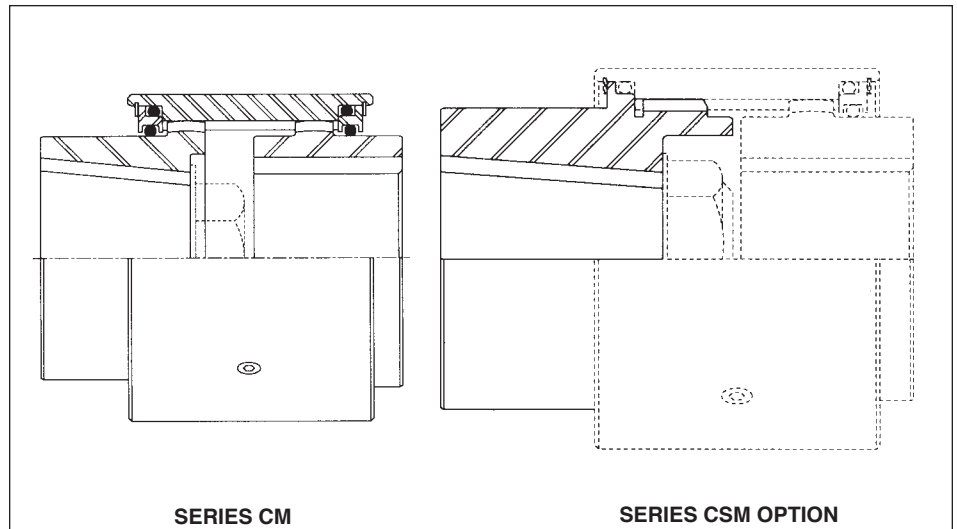
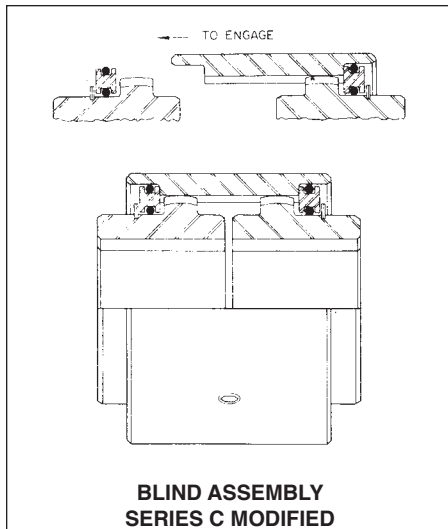
Description: Standard stock hubs and sleeves are used in the CL construction. The CL Series has the advantage of reduced weight, compact design and lower WR².

Dam rings are designed with inlet ring and outlet ring openings at different levels to assure positive oil flow, controlled oil level and oil level retention in the event the oil supply is interrupted. The outlet ring has angled discharge holes to minimize sludge accumulation.

Amerigear

Flexible Couplings

Modifications and Variations Series C



Blind Assembly Modification — Series C

Application: Recommended for plug-in type installations, as with flange or frame-mounted equipment. Also used where short shaft extensions of bell housings restrict installation of standard Series C Coupling. May be used in horizontal or vertical positions.

Description: Amerigear Series C (Modified), Blind Assembly type Flexible Coupling retains all the features and overall dimensions of standard Series C Coupling. Snap-ring groove is machined into hub allowing preassembly of seal assembly to hub before shafts are connected.

Mill Motor CM Coupling

Application:

The CM and CSM couplings are designed for applications which utilize shafts having tapered shaft ends, i.e., AISE mill motors. These couplings offer the advantage of lower weight, minimum outer diameter and low WR^2 .

Description: The CM and the CSM couplings use standard stock sleeves. The couplings can be made with any combination of hub bores. For example, one or both hubs with tapered bores; one tapered and one straight bore.

Modifications and Variations

Series C

Continuous Sleeve Axial Travel

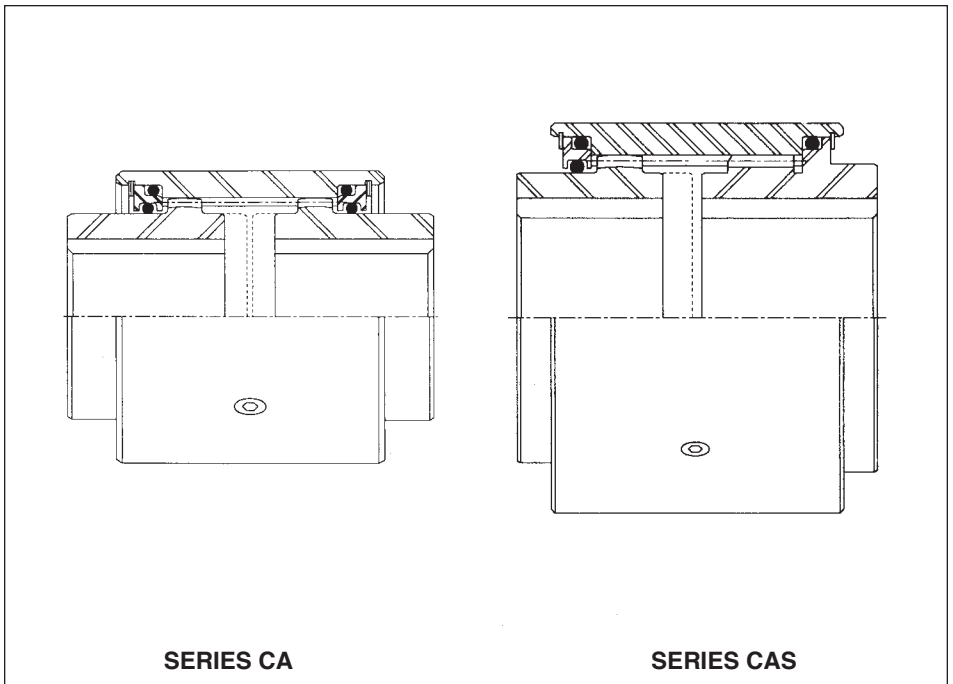
Application: The CA and CAS type couplings are designed to provide axial travel between driver and driven shafts such as with certain crane and fan equipment. Compared to the Series F, the CA and CAS advantages are lower weight and WR, higher speeds and a more compact design.

Description: The Amerigear CA couplings have a one piece sleeve that engages both shaft hubs. The coupling is sealed with seal retainers and O-rings. The coupling is assembled with spiral type retaining rings.

The CAS coupling differs from the CA using a rigid hub in place of one flex hub and has one less seal retainer and O-ring.

Depending on the dimensions required, the coupling usually can be made from stock sleeves and modified stock hubs or a made-to-order may be possible.

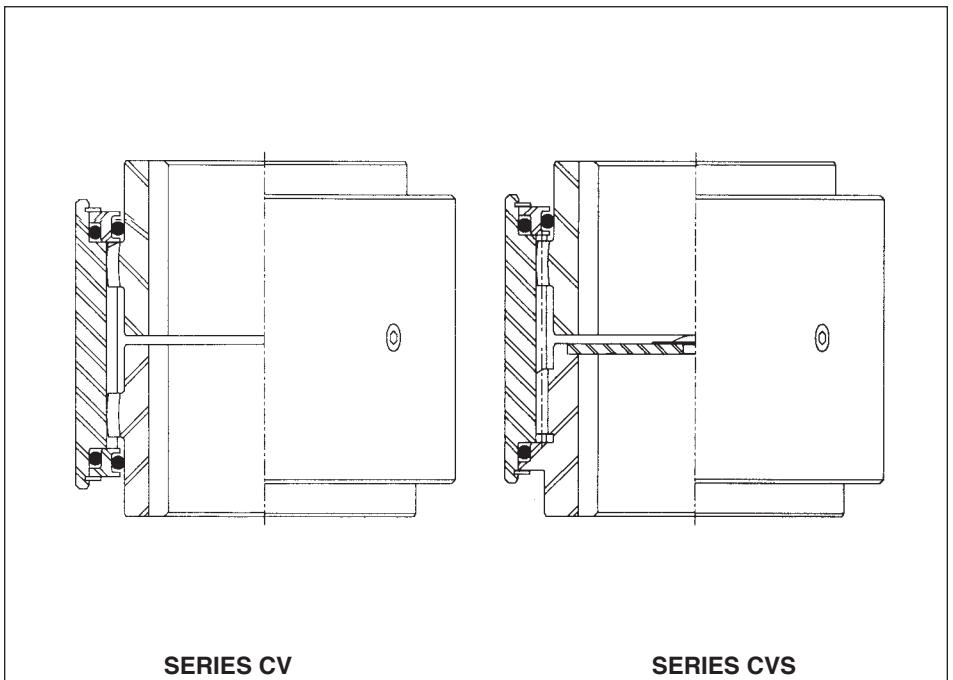
The couplings are limited to $\pm 1/2^\circ$ angular misalignment per flex half.



Continuous Sleeve Vertical Coupling

Application: The CV and CVS couplings are used to connect driver and driven equipment having vertical shafts. While the CV compensates for all three types of misalignment, the CVS compensates only for angular.

Description: The CV coupling is constructed from a stock sleeve, seals, seal retainers and retainer rings and from modified stock hubs. The CVS coupling uses a stock rigid hub in place of one flex hub and one less seal.



Amerigear

Flexible Couplings

Engineering Data Speeds, Classes and Balance

Speeds The speed limits at right are recommendations based on experience and are intended as a guide only. The actual limits are determined by the characteristics of the system in which the coupling is to be installed.

Consult Ameridrives, for speed limits of series not listed at right.

Classes Four classes of Amerigear couplings are available.

1. Standard AMERIGEAR Couplings
2. Balanced Standard AMERIGEAR Couplings
3. Class III AMERIGEAR Couplings
4. Class I AMERIGEAR Couplings

I. Standard Couplings.

These couplings offer fully-crowned teeth. Sizes 200 - 207 have $\pm 1\frac{1}{2}^\circ$ angular misalignment capacity per mesh. Sizes 208 - 210 have $\pm \frac{3}{4}^\circ$.

Parts are fully-machined from medium carbon steel. These couplings also feature self-locking nuts and positive type O-ring seals.

II. Balanced Standard Couplings.

This class is offered in Series F and FE for sizes 201 $\frac{1}{2}$ - 207. These couplings are Standard Couplings which have been dynamically balanced as components. They offer all the features as Standard Couplings but, because of the increased speed rating of the Balanced Standard Class of couplings, the rated angular misalignment is limited to $\pm 1^\circ$. These couplings will meet an AGMA Balance Classification (see page 35). Series F meet AGMA Class 9. Series FE meet AGMA Class 8.

NOTE: Series FE are supplied with pilot rings and are only available up to a 10" length of spacer.

III. Class III Couplings.

These couplings offer all the features of our standard line, plus additional modifications which permit higher operating speeds. They are made of medium carbon steel and conform to dimensions of standard couplings, and are available through size 205 $\frac{1}{2}$.

Size	F	F Balanced	F Class III	F Class I	C	FPH	FPH Class III	* FD, FDC
200	8,500				11,000			
201	7,700			32,000	9,800			
201 $\frac{1}{4}$	7,100			32,000	8,900			
201 $\frac{1}{2}$	5,400	9,000	12,600	25,000	7,700	4,200	8,200	
202	4,800	8,100	11,400	20,000	6,200	3,800	7,400	1,800
202 $\frac{1}{2}$	4,300	6,900	9,500	18,000	6,000	3,400	6,150	1,600
203	4,000	6,100	8,200	15,000	5,200	3,200	5,300	1,200
203 $\frac{1}{2}$	3,600	5,400	7,200	13,000	4,400	2,800	4,700	1,000
204	3,200	4,750	6,300	11,500	3,550	2,500	4,100	900
204 $\frac{1}{2}$	3,000	4,450	5,900	10,500	3,000	2,400	3,800	850
205	2,600	4,000	5,400	9,600	2,600	2,000	3,500	750
205 $\frac{1}{2}$	2,400	3,500	4,600	9,000	2,400	1,900	3,000	650
206	2,200	3,250		8,400	2,200	2,200	2,800	600
207	1,800	2,750		6,800	1,800	1,800	2,400	550
208	1,500				1,800			
209	1,275				1,650			
210	1,100				1,400			

*THESE ARE MAXIMUM SPEEDS FOR FD WHEN DISENGAGED AND FOR FDC WHEN ENGAGED OR DISENGAGED. FOR FD WHEN ENGAGED, FOLLOW STANDARD F SPEEDS.

The hubs and sleeves of the Class III couplings minimize gear tooth tip clearance, and the sleeves incorporate integral pilots, both providing accurate centering of mating sleeves, spacer or tandem shafts. These couplings are dynamically balanced as components and will meet AGMA classifications as designated below. Sleeves and spacers are serialized for ease of identification.

Because of the increased speed rating of the Class III Coupling, the rated angular misalignment is limited to $\pm \frac{3}{4}^\circ$.

The Class III Coupling is available in the following series:

F	Page 8, AGMA Class 10
FL	Page 28, AGMA Class 10
FE	Page 19, AGMA Class 9
FS, ES	Page 10 and 24, AGMA
Tandem	Class 8 and 9
FPH	Page 22, AGMA Class 8 and 9

NOTE: Class depends on length and size of coupling.

IV. Class I Couplings.

These are high-performance alloy couplings with nitrided gear teeth which are rated at $\pm \frac{1}{4}^\circ$. Information on this class of gear coupling is not covered in this catalog. Contact Ameridrives and request Amerigear Class I catalog, 462-ADV.

Engineering Data

Speeds, Classes and Balance

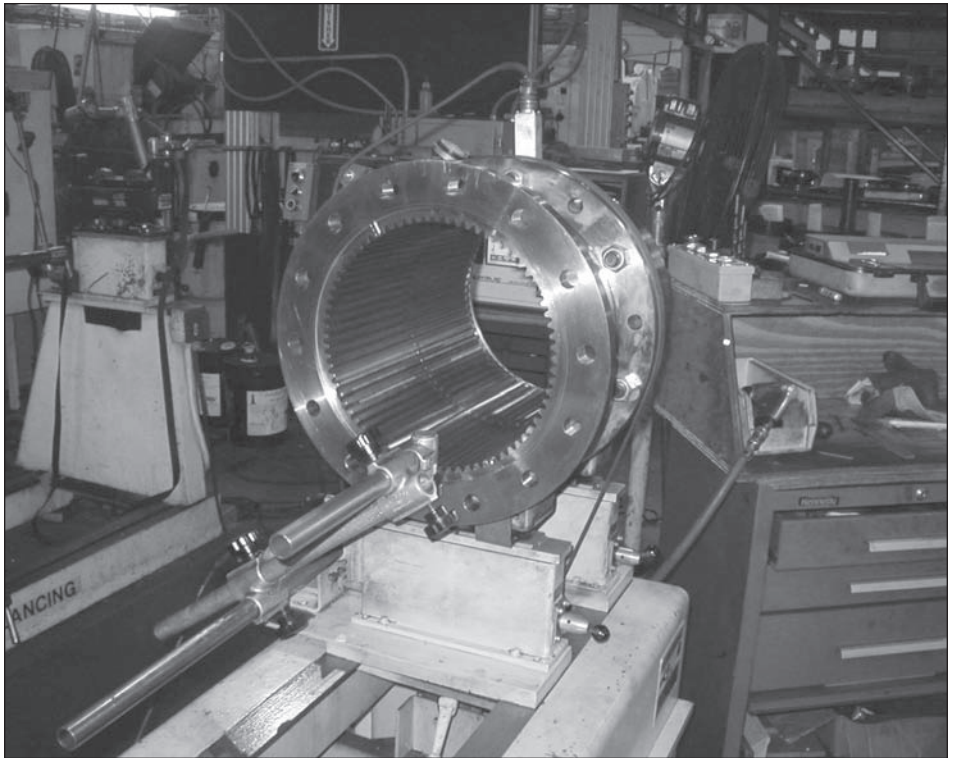
Balance Procedure All components of Balanced Standards are dynamically balanced within .00015 inches peak-to-peak, which is equivalent to a mass shift of 75 micro-inches. All components of Class III couplings are dynamically balanced within .0001 inches peak-to-peak, which is equivalent to a mass shift of 50 micro-inches.

All hubs, sleeves, rigids and other short parts other than unbalanced standard parts, are single plane balanced on Ameridrives designed vertical balance machines.

Spacers, tandem shaft assemblies and other long parts, other than unbalanced standard parts, are two plane balanced on an IRD horizontal balance machine. All balancing operations are performed using state-of-the-art IRD Analyzers.

Class III coupling components balance records are retained in the Quality Control Department. Copies of balance records are available on customer request.

Contact Ameridrives International for balancing needs.



Balancing minimizes damaging vibrations for applications in the higher speed ranges . . . and where supporting structures and housings become lighter.

UNBALANCE DATA FOR AMERIGEAR FLEXIBLE COUPLINGS

Table 1:
Standard AGMA Balance Classification

AGMA COUPLING BALANCE CLASS	MAXIMUM DISPLACEMENT OF PRINCIPAL INERTIA AXIS (RMS Micro-Inches)
6	16,000
7	8,000
8	4,000
9	2,000
10	1,000
11	500

Ref.: ANSI/AGMA 9000-C90.

Table 2:
Amerigear Balance Classification

AMERIDRIVES CLASSIFICATION	AGMA CLASS	
	F Coupling	FE Coupling
Standard	8	7
Balanced Standard	9	8
Class III	10	9
Class I	11	10

The approximate unbalance "U" of a coupling, per plane, expressed in Oz.-In., may be found by:

$$U = \frac{16 \times W \times D}{1,000,000}$$

where W = Half coupling weight in Lbs.
D = RMS displacement in micro-inches from Table 1.

RMS = Root Mean Squared average.

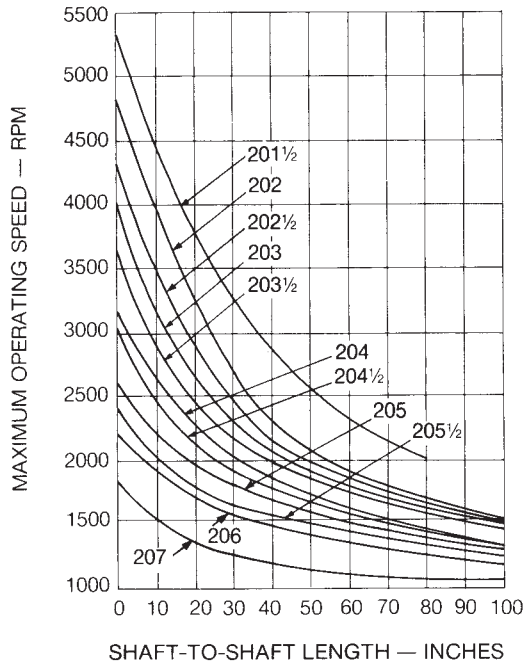
Amerigear

Flexible Couplings

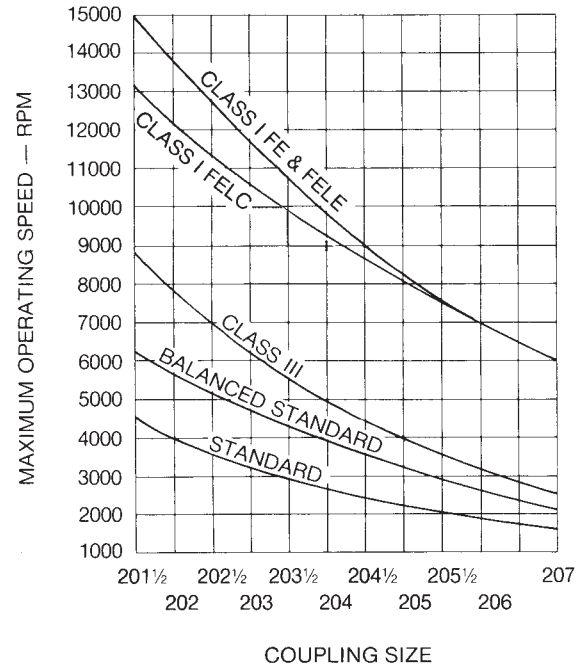
Engineering Data

Maximum Speeds, Series FE and FEL

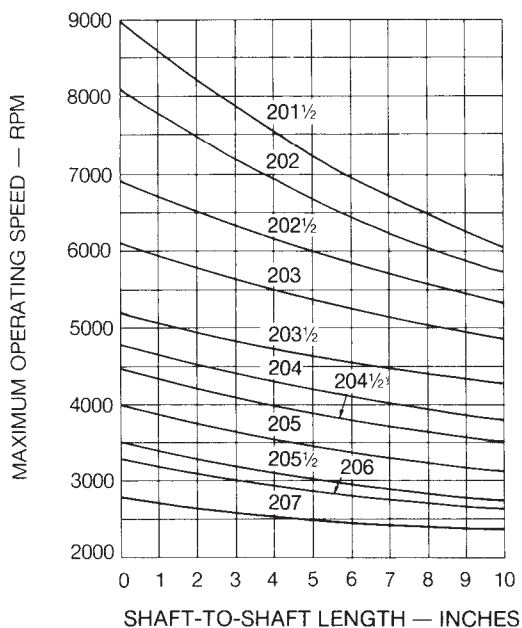
STANDARD FE AND FEL



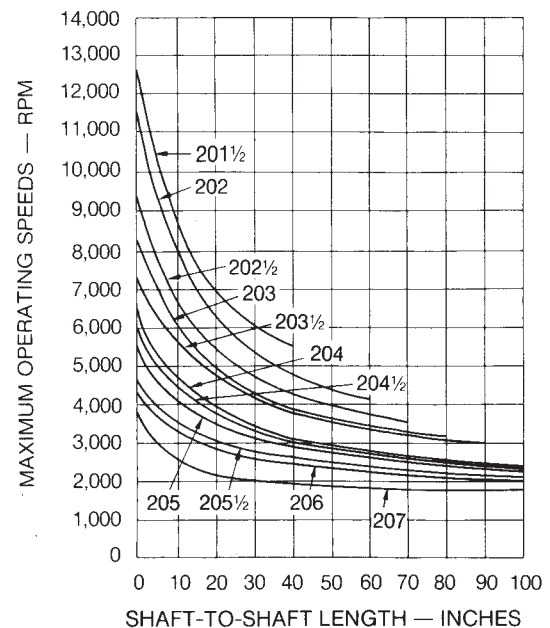
FE AND FEL AT 10-INCH SHAFT-TO-SHAFT



BALANCED STANDARD FE AND FEL



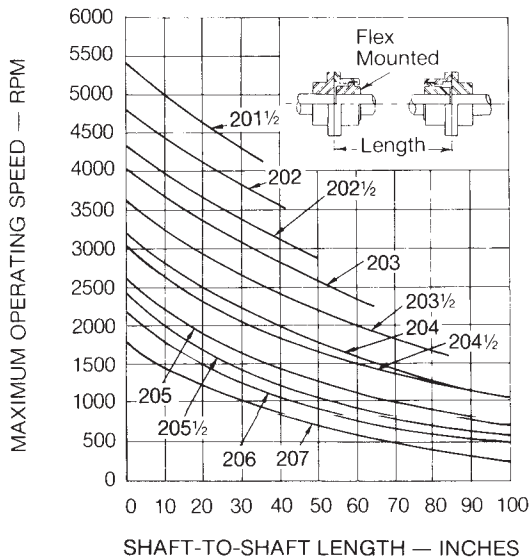
CLASS III FE AND FEL



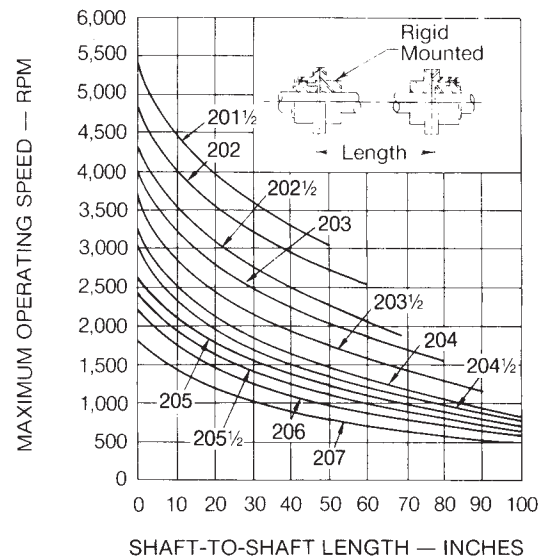
NOTE: THE MAXIMUM SPEEDS ON THIS PAGE ARE ONLY A GUIDE. THE ACTUAL LIMITS ARE DETERMINED BY THE CHARACTERISTICS OF THE SYSTEM IN WHICH THE COUPLING IS INSTALLED. FOR LENGTHS GREATER THAN SHOWN, CONTACT AMERIDRIVES INTERNATIONAL.

Maximum Speeds, Series FS Tandem

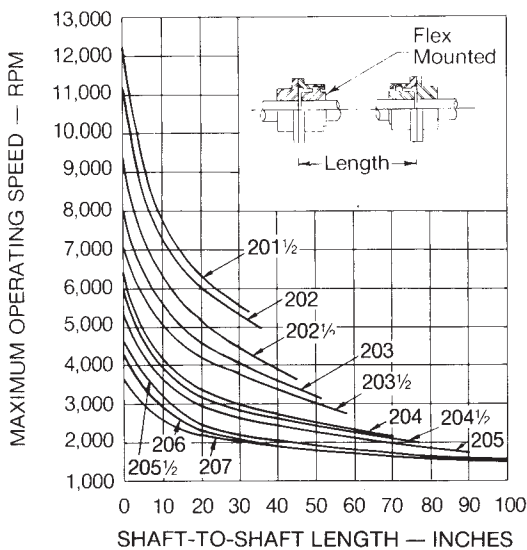
**STANDARD FS
FLEX HUB MOUNTED ON TANDEM SHAFT.**



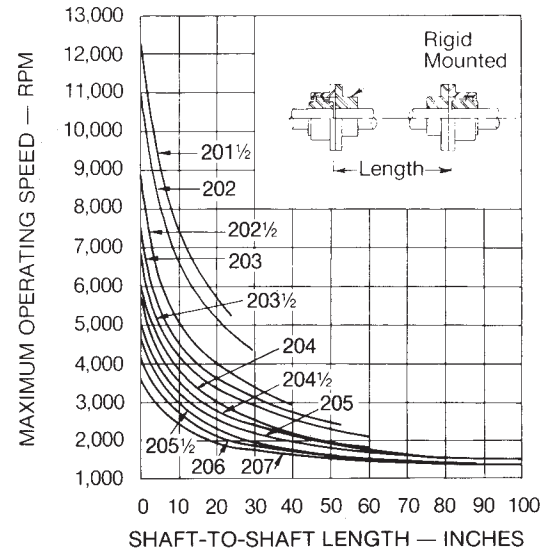
**STANDARD FS
RIGID HUB MOUNTED ON TANDEM SHAFT.**



**CLASS III FS
FLEX HUB MOUNTED ON TANDEM SHAFT.**



**CLASS III FS
RIGID HUB MOUNTED ON TANDEM SHAFT.**



NOTE: THE MAXIMUM SPEEDS ON THIS PAGE ARE ONLY A GUIDE. THE ACTUAL LIMITS ARE DETERMINED BY THE CHARACTERISTICS OF THE SYSTEM IN WHICH THE COUPLING IS INSTALLED.
SEE PAGE 24 FOR SHAFT SIZES USED IN THESE CHARTS.
IF INTERMEDIATE SHAFT IS NOT SUPPLIED BY AMERIDRIVES, A CRITICAL SPEED CHECK SHOULD BE MADE BY CUSTOMER.
FOR LENGTHS GREATER THAN SHOWN, CONTACT AMERIDRIVES INTERNATIONAL.

Amerigear

Flexible Couplings

Weights WR², Torsional Stiffness and Engineering Calculations

SIZES 200-207 SERIES F AND C — WEIGHT-LBS.

Size	Solid Hub F&C	Solid Rigid	Sleeve		Spacer Less Tube	Tube Wt/In.	Shaft Wt/In.	Coupling With Solid Hubs		FS Coupling Solid Hub & Rigid	FE Coupling Less Tube w/ Solid Hubs
			F	C				F	C		
200	.42	1.35	.74	.85	1.06	.18	.19	2.3	1.8	2.5	3.36
201	1.04	2.36	1.20	1.32	1.36	.25	.28	4.5	3.6	4.6	5.86
201¼	1.88	3.46	1.63	1.96	2.62	.29	.36	7.0	6.0	7.0	9.62
201½	4.50	10.00	3.90	4.60	7.32	.91	.84	17.0	14.0	18.6	24.32
202	9.06	17.00	5.70	7.60	11.00	1.46	1.39	30.0	27.0	32.2	41.00
202½	16.80	29.50	9.00	12.00	18.30	1.58	2.00	53.0	47.0	56.7	71.30
203	27.50	44.00	12.80	18.00	21.80	2.04	2.73	82.0	75.0	85.7	103.80
203½	40.80	69.00	21.60	25.00	36.40	2.36	3.56	127.0	109.0	134.0	163.40
204	65.40	103.00	29.70	38.80	45.40	3.16	5.56	193.0	174.0	200.0	238.40
204½	98.20	140.00	33.60	42.00	53.50	3.50	5.56	266.0	242.0	275.0	319.50
205	126.00	206.00	55.60	51.00	95.40	3.63	8.01	368.0	308.0	392.0	463.40
205½	168.00	260.00	73.10	57.50	108.00	4.30	8.01	488.0	400.0	507.0	596.00
206	232.00	360.00	83.60	80.00	87.20	4.60	10.50	640.0	550.0	685.0	727.20
207	363.00	553.00	117.20	128.00	131.00	5.23	14.20	973.0	862.0	1,045.0	1,104.00

SIZES 200-207 SERIES F AND SIZES 200-207 SERIES C - WR² (LB.-IN.²)

Size	Solid Hub F&C	Solid Rigid	Sleeve		Spacer Less Tube	Tube WR ² /In.	Shaft WR ² /In.	Coupling With Solid Hubs		FS Coupling Solid Hub & Rigid	FE Coupling Less Tube w/ Solid Hubs
			F	C				F	C		
200	.10	1.13	1.00	1.6	.72	.12	.02	2.2	1.8	2.46	2.92
201	.51	2.94	2.39	2.0	1.46	.32	.07	5.8	3.0	6.84	7.26
201¼	1.41	5.47	4.14	3.8	2.26	.50	.19	11.1	6.6	13.58	13.40
201½	5.90	34.00	22.00	19.0	49.80	2.72	.39	58.0	33.0	64.10	107.80
202	19.10	75.70	43.60	46.0	89.40	7.03	1.09	129.0	89.0	142.00	218.40
202½	52.80	185.00	119.00	109.0	215.00	10.60	2.25	319.0	224.0	332.00	534.00
203	118.00	350.00	180.00	212.0	335.00	19.20	4.17	617.0	471.0	669.00	952.00
203½	225.00	732.00	400.00	374.0	750.00	29.10	7.11	1,304.0	855.0	1,411.00	2,054.00
204	508.00	1,386.00	719.00	813.0	1,225.00	53.20	17.40	2,536.0	1,920.0	2,695.00	3,761.00
204½	1,023.00	2,250.00	1,014.00	1,100.0	1,720.00	70.10	17.40	4,174.0	3,239.0	4,387.00	5,894.00
205	1,489.00	4,360.00	2,090.00	1,562.0	3,880.00	90.50	36.00	7,373.0	4,688.0	8,154.00	11,253.00
205½	2,419.00	6,400.00	3,184.00	2,098.0	5,230.00	130.00	36.00	11,496.0	7,134.0	12,293.00	16,726.00
206	4,107.00	8,800.00	4,217.00	3,486.0	4,920.00	159.00	66.70	17,130.0	11,904.0	17,606.00	22,050.00
207	8,552.00	18,800.00	8,044.00	7,638.0	9,760.00	238.00	114.00	34,287.0	25,188.0	36,491.00	44,047.00

TORSIONAL STIFFNESS (Kt) IN.-LB. x 10⁶ RAD.

Size	Nominal Bore of Hub & Rigid	KA/Inch Shaft	KN/Inch Tube	KS C Coupling Nom. Bore	KS F Coupling Nom. Bore	KS FS Coupling Nom. Bore	KE FE Coupling Less Tube w/ Nom. Bore
200	.75	.68	4.87	.34	.35	.41	.35
201	1.00	2.75	12.90	.86	.86	1.02	.86
201¼	1.25	7.78	28.34	1.60	1.58	1.92	1.58
201½	1.50	15.99	100.38	3.63	3.43	3.88	3.31
202	2.00	44.10	256.36	8.68	7.84	9.08	7.49
202½	2.50	91.00	418.56	16.87	14.61	17.02	13.94
203	3.00	169.00	760.52	28.66	25.16	29.53	23.88
203½	3.50	289.00	963.36	44.32	40.09	46.93	38.42
204	4.00	705.00	1,469.00	69.09	61.25	71.87	58.06
204½	4.50	705.00	2,356.00	99.76	85.79	101.12	80.57
205	5.00	1,460.00	4,144.00	126.94	111.40	132.36	105.72
205½	5.50	1,460.00	5,110.00	169.56	152.78	181.63	144.67
206	6.00	2,710.00	6,455.00	222.07	189.96	220.81	176.71
207	7.00	4,620.00	9,660.00	335.94	287.14	340.09	268.09

I. To find Wt. and WR² of a coupling not shown on chart, add Wt. and WR² of components and subtract Wt. and WR² of required bores. See page 39.

II. To find Torsional Stiffness (Kt) of FS Tandem Coupling:

$$KT = \frac{1}{\frac{2}{K_s} + \frac{N}{K_A}}$$

N = Length of shaft between Mtd. hubs or rigids.
For rigid Mtd. — N = Shaft-to-shaft - 2xD - 2xC'
For flex Mtd. — N = Shaft-to-shaft - 2xD - 2xC
Find D, C, C' on page 10.

To find Torsional Stiffness (Kt) of FE Tandem Coupling:

$$KT = \frac{1}{\frac{1}{K_E} + \frac{N}{K_N}}$$

N = Length of spacer tube between flanges.
N = Shaft-to-shaft - D-2Q (Find Q on page 41.)

Weights WR^2 , Torsional Stiffness and Engineering Calculations

SERIES F AND C – WEIGHTS

Size	Large Coupling with Solid Hubs		
	F	F - Opt.	C
208	1,440	1,496	1,237
209	1,989	2,051	1,707
210	2,543	2,543	2,141
211	3,370	3,441	—
212	4,240	4,320	—
213	5,350	5,440	—
214	6,550	6,640	—
215	7,880	8,020	—
216	9,490	9,960	—
218	12,900	13,600	—
220	17,100	18,100	—
222	22,700	24,100	—
224	29,100	30,800	—
226	36,900	39,500	—
228	45,000	45,300	—
230	54,500	55,100	—

SERIES F AND C – WR^2 - LB./IN.² x 10³

Size	Large Coupling with Solid Hubs		
	F	F - Opt.	C
208	65.8	71.1	45.7
209	114.0	121.3	107.3
210	166.7	178.6	124.2
211	267.4	279.8	—
212	390.2	405.6	—
213	581.3	600.3	—
214	806.9	829.9	—
215	1,095.0	1,136.0	—
216	1,550.0	1,696.0	—
218	2,513.0	2,784.0	—
220	4,263.0	4,459.0	—
222	6,394.0	7,273.0	—
224	9,649.0	10,824.0	—
226	14,543.0	16,647.0	—
228	20,126.0	20,389.0	—
230	27,460.0	28,271.0	—

SERIES FS – WEIGHT AND WR^2 - LB./IN.²

Size	Larger Coupling With Solid Hub and Rigid			
	Weight (Lbs.)		WR^2 - Lb./in. ² x 10 ³	
	FS	FS - Opt.	FS	FS - Opt.
208	1,482	1,526	68.2	72.5
209	2,044	2,093	117.6	123.4
210	2,659	2,725	177.9	187.3
211	3,630	3,670	298.0	304.2
212	4,550	4,590	444.5	452.2
213	5,730	5,780	641.7	651.3
214	6,980	7,020	877.0	898.5
215	8,380	8,450	1,202.0	1,222.0
216	10,380	10,530	1,771.0	1,814.0
218	14,100	14,200	2,882.0	3,522.0
220	18,600	18,700	4,559.0	4,649.0
222	24,700	24,900	7,328.0	7,430.0
224	31,400	31,600	11,006.0	11,135.0
226	41,400	41,600	16,902.0	17,093.0
228	48,600	48,800	23,093.0	23,356.0
230	57,500	58,100	29,914.0	30,725.0

ENGINEERING CALCULATIONS

I. Solid Disc (Fig. 1)

A. Weights-Lbs.

$$W = .223 L D^2$$

B. WR^2 - Lb.-in.²

$$WR^2 = \frac{W}{8} D^2$$

C. Torsional Stiffness - In.-Lb./Radian

$$K = \frac{1.13 \times 10^6 (D^4)}{L}$$

II. Disc With Hole (Fig. 2)

A. Weights-Lbs.

$$W = .223 L (D^2 - d^2)$$

B. WR^2 - Lb.-in.²

$$WR^2 = \frac{W}{8} (D^2 + d^2)$$

C. Torsional Stiffness - In.-Lb./Radian

$$K = \frac{1.13 \times 10^6 (D^4 - d^4)}{L}$$

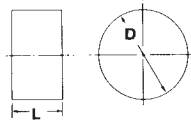


FIG. 1

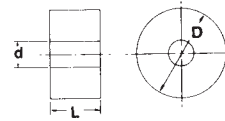


FIG. 2

III. Misalignment

1. Angular Misalignment

A gear coupling accommodates for various types of misalignment by angular displacement of its gear teeth (Fig. 3).

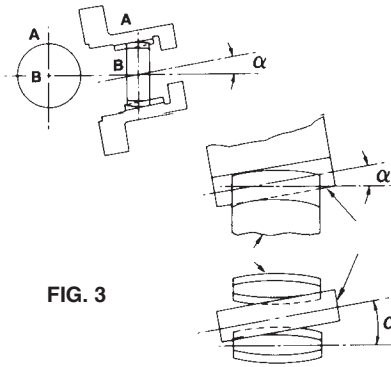


FIG. 3

A single gear mesh can only accommodate angular misalignment (Fig. 4).

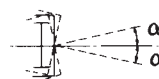
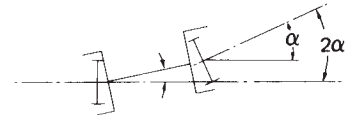


FIG. 4

Fig. 5 shows a double engagement coupling made up of two meshes having $\pm\alpha^\circ$ capacity each. Together, they will provide a total angular capacity of $\pm 2\alpha^\circ$.

FIG. 5



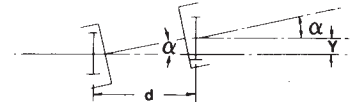
2. Fig. 6 shows a double engagement coupling of two meshes each having $\pm 2\alpha^\circ$. If the distance between meshes is "d", then the maximum parallel offset "Y" is equal to:

$$Y = d \tan \alpha^\circ$$

$$a = \text{rated misalignment}$$

α°	TAN α°
1/4	.0044
1/2	.0087
3/4	.0131
1	.0174
1 1/2	.0262

FIG. 6



3. The third type of misalignment is when we have a combination of angular and parallel offset.

To find the amount of angular capacity allowed, when we know the amount of offset:

$$\alpha_{\text{allow}} = \alpha_{\text{rated}} - \tan^{-1} \left(\frac{Y}{d} \right)$$

To find the amount of parallel allowed, if angular misalignment (α_1) is known:

$$Y = d \tan (\alpha_{\text{rated}} - \alpha_1)$$

IV. Axial Thrust Transmitted To Thrust Bearings

$$F = (T \times \mu) / R$$

$\mu = .03$ to $.3$ (depending on lubrication). Generally, use $.15$.

R = Pitch Radius

The last two digits of a coupling size is approximately equal to the pitch radius.

Ex. $203\frac{1}{2}$ R = $3\frac{1}{2}$
211 R = 11

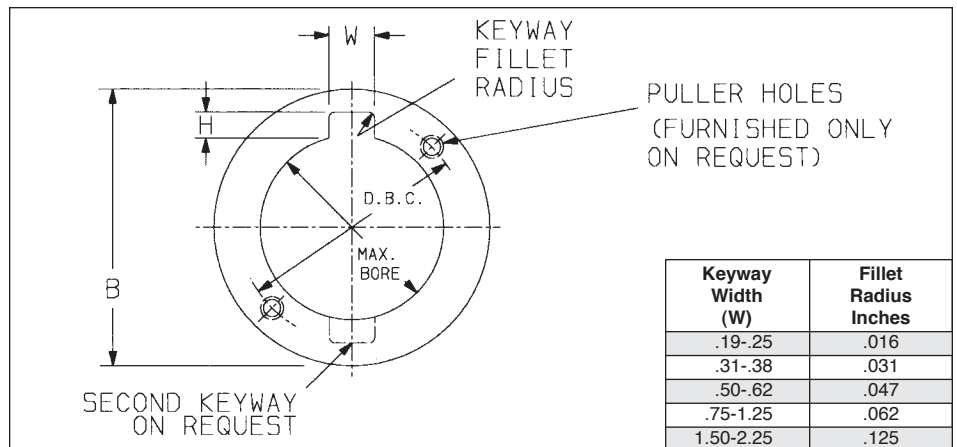
T = Operating Torque - In.-Lbs.

Amerigear

Flexible Couplings

Maximum Bore, Keyway and Puller Hole Data Series F, FS, C, CS

F,C and CS Size	Max. Bore With Puller Holes	Puller Holes	
		DBC	Size
200	—	—	—
201	1.00	1.375	1/4-28
201 1/4	1.44	1.812	1/4-28
201 1/2	2.00	2.625	5/16-18
202	2.75	3.375	5/16-18
202 1/2	3.25	4.187	3/8-16
203	4.00	4.875	1/2-13
203 1/2	4.38	5.437	5/8-11
204	5.50	6.625	5/8-11
204 1/2	6.50	7.875	5/8-11
205	6.62	8.250	3/4-10
205 1/2	7.00	8.750	1-8
206	8.25	10.000	1-8
207	9.00	11.375	1 1/4-7
208	11.25	13.500	1 1/4-7
209	12.25	15.250	1 3/8-6
210	13.75	16.500	1 1/2-6
211	15.00	18.000	1 1/2-6
212	17.00	20.000	1 1/2-6
213	19.00	22.000	1 1/2-6
214	20.00	23.500	1 3/4-5
215	22.00	25.500	1 3/4-5
216	23.50	27.000	1 3/4-5
218	26.50	30.500	2-4 1/2
220	30.00	34.500	2-4 1/2
222	33.00	38.500	2-4 1/2
224	36.00	42.500	2-4 1/2
226	39.00	46.000	2-4 1/2
228	42.00	50.000	2-4 1/2
230	46.00	54.000	2-4 1/2



F and C Size	Stock Rough Bore*	Reduced Key			Square Key			Hub Dia. B
		Bore	W	H	Bore	W	H	
200	—	.875	.19	.06	.812	.19	.09	1.25
201	—	1.312	.25	.09	1.250	.25	.12	1.75
201 1/4	—	1.750	.38	.12	1.625	.38	.19	2.25
201 1/2	—	2.375	.50	.19	2.250	.50	.25	3.12
202	—	2.875	.62	.22	2.750	.62	.31	4.00
202 1/2	—	3.750	.88	.31	3.500	.88	.44	4.88
203	—	4.250	1.00	.38	4.000	1.00	.50	5.75
203 1/2	1.500	4.750	1.00	.38	4.500	1.00	.50	6.50
204	1.500	5.875	1.25	.44	5.500	1.25	.62	7.75
204 1/2	2.375	6.750	1.50	.50	6.250	1.50	.75	9.00
205	3.375	6.750	1.75	.75	6.625	1.75	.88	9.50
205 1/2	3.375	7.625	1.75	.75	7.500	1.75	.88	10.50
206	4.500	8.625	2.00	.75	8.250	2.00	1.00	11.75
207	5.000	10.250	2.50	.88	9.625	2.50	1.25	13.50

*MINIMUM BORE IS .060 INCHES GREATER THAN ROUGH BORE SIZE.

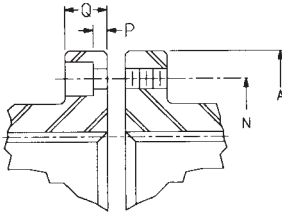
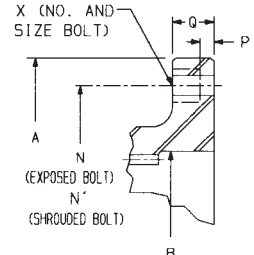
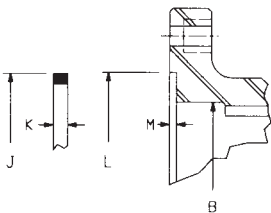
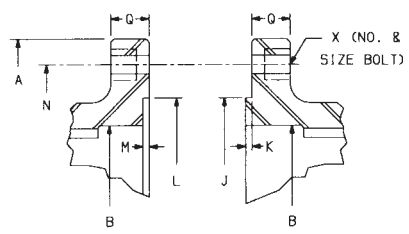
NOTE: THESE TABLES ARE EXCLUSIVE. IF BOTH PULLER HOLES AND KEYWAYS ARE REQUIRED, THEN THE MAXIMUM BORE WILL BE THE SMALLER BORE SIZE LISTED IN ANY TABLE.

FS Size	Rigid Half — Series FS							Rigid Half — Series CS						
	Reduced Key			Square Key			Rigid Half Dia. B	Reduced Key			Square Key			Rigid Half Dia. B
	Bore	W	H	Bore	W	H		Bore	W	H	Bore	W	H	
200	1.375	.31	.12	1.312	.31	.16	1.94	1.000	.19	.06	.875	.19	.09	1.25
201	1.875	.38	.12	1.750	.38	.19	2.56	1.375	.31	.12	1.312	.31	.16	1.75
201 1/4	2.125	.50	.19	2.000	.50	.25	3.00	1.750	.38	.12	1.625	.38	.19	2.25
201 1/2	2.875	.62	.22	2.688	.62	.31	3.92	2.375	.62	.22	2.250	.50	.25	3.50
202	3.500	.88	.31	3.250	.88	.44	4.86	3.000	.75	.25	2.750	.62	.31	4.25
202 1/2	4.250	1.00	.38	4.000	1.00	.50	5.86	3.750	.88	.31	3.500	.88	.44	5.25
203	5.000	1.25	.44	4.625	1.25	.62	6.86	4.250	1.00	.38	4.000	1.00	.50	6.12
203 1/2	5.750	1.25	.44	5.375	1.25	.62	7.88	4.875	1.25	.44	4.500	1.00	.50	6.81
204	6.750	1.50	.50	6.250	1.50	.75	9.22	5.875	1.25	.44	5.500	1.25	.62	8.00
204 1/2	7.375	1.75	.62	6.875	1.75	.88	10.18	6.750	1.50	.50	6.250	1.50	.75	9.25
205	8.375	1.75	.62	7.87	1.75	.88	11.44	7.000	1.75	.62	6.625	1.75	.88	10.00
205 1/2	9.250	2.00	.75	8.750	2.00	1.00	12.69	8.000	2.00	.75	7.500	1.75	.88	11.00
206	9.875	2.00	.75	9.375	2.00	1.00	13.75	8.625	2.00	.75	8.250	2.00	1.00	12.00
207	11.500	2.50	.88	10.750	2.50	1.25	15.75	10.250	2.50	.88	9.625	2.50	1.25	13.75

CONTACT AMERIDRIVES INTERNATIONAL REGARDING BORES FOR HUBS OR RIGID HALVES WHERE COUNTERBORES, REDUCED LENGTHS, OVERBORES OR SPECIAL KEYWAYS ARE INVOLVED.

Dimensional Data

Flange Details, Series F

 <p style="text-align: center;">SIZES 200-201¹/₄</p> <p>NOTE FASTENERS ARE SELF-LOCKING SOCKET HEAD CAPSCREWS</p>	 <p style="text-align: center;">SIZES 201¹/₂-207</p>	 <p style="text-align: center;">SIZES 201¹/₂-207</p> <p>FEMALE SLEEVES FURNISHED AS SHOWN ABOVE WHEN PILOT RINGS ARE SUPPLIED.</p>	 <p style="text-align: center;">SIZES 208 AND LARGER</p>
---	--	---	--

Size	A	N	D.B.C.	P	Q	Bolt No.	Bolt Size
200	2.937	2.38	.12	.44	.44	4	1/4-28
201	3.562	3.00	.12	.44	.44	4	1/4-28
201 ¹ / ₄	4.000	3.44	.12	.44	.44	4	1/4-28

Size	COMMON DIMENSIONS							EXPOSED BOLT			SHROUDED BOLT			
	A	B	J	K	L	M	Q	N	X (Bolts)		N'	P	X (Bolts)	
								D.B.C.	No.	Size	D.B.C.		No.	Size
201 ¹ / ₂	6.00	3.69	3.844/3.842	.16	3.844/3.846	.09	.75	4.81	8	3/8	4.81	.22	8	3/8
202	7.00	4.56	4.750/4.748	.16	4.750/4.752	.09	.75	5.88	6	1/2	5.81	.22	10	3/8
202 ¹ / ₂	8.38	5.56	5.750/5.748	.16	5.750/5.752	.09	.88	7.12	6	5/8	7.00	.28	10	1/2
203	9.44	6.47	6.750/6.748	.16	6.750/6.752	.09	.88	8.12	8	5/8	8.00	.28	12	1/2
203 ¹ / ₂	11.00	7.26	7.516/7.514	.16	7.516/7.518	.09	1.06	9.50	8	3/4	9.28	.33	12	5/8
204	12.50	8.56	9.000/8.998	.31	9.000/9.002	.19	1.06	11.00	8	3/4	10.62	.33	14	5/8
204 ¹ / ₂	13.62	9.81	10.125/10.123	.31	10.125/10.127	.19	1.06	12.00	10	3/4	11.75	.33	14	5/8
205	15.31	10.73	11.125/11.123	.31	11.125/11.127	.19	1.50	13.50	8	7/8	13.19	.52	14	3/4
205 ¹ / ₂	16.56	11.73	12.500/12.498	.31	12.500/12.502	.19	1.50	14.50	14	7/8	14.44	.52	16	3/4
206	18.00	12.73	13.500/13.498	.44	13.500/13.502	.25	1.00	15.75	14	7/8	-	-	-	-
207	20.75	15.06	15.500/15.498	.56	15.500/15.502	.31	1.12	18.25	16	1	-	-	-	-
208	23.25	17.06	17.809/17.806	.25	17.812/17.815	.31	1.31	20.75	16	1 1/8	-	-	-	-
209	26.00	19.06	19.809/19.806	.25	19.812/19.815	.31	1.50	23.25	18	1 1/4	-	-	-	-
210	28.00	20.56	21.557/21.554	.31	21.562/21.565	.38	1.50	25.25	18	1 3/8	-	-	-	-
211	30.50	23.00	23.997/23.994	.31	24.000/24.003	.38	1.62	27.50	18	1 1/2	-	-	-	-
212	33.00	25.00	25.997/25.994	.31	26.000/26.003	.38	1.62	30.00	18	1 1/2	-	-	-	-
213	35.75	27.00	27.997/27.994	.31	28.000/28.003	.38	1.75	32.25	18	1 5/8	-	-	-	-
214	38.00	29.00	29.997/29.994	.31	30.000/30.003	.38	1.88	34.50	18	1 3/4	-	-	-	-
215	40.50	31.00	31.997/31.994	.31	32.000/32.003	.38	1.88	36.75	20	1 3/4	-	-	-	-
216	44.50	33.25	34.246/34.242	.38	34.250/34.254	.50	2.25	40.50	20	2	-	-	-	-
218	48.50	37.25	38.246/38.242	.38	38.250/38.254	.50	2.25	44.50	22	2	-	-	-	-
220	52.50	41.25	42.246/42.242	.38	42.250/42.254	.50	2.25	48.50	24	2	-	-	-	-
222	58.00	45.25	46.496/46.492	.50	46.500/46.504	.62	2.50	53.50	24	2 1/4	-	-	-	-
224	62.88	49.25	50.496/50.492	.50	50.500/50.504	.62	2.75	58.12	24	2 1/2	-	-	-	-
226	69.00	53.62	54.496/54.492	.50	54.500/54.504	.62	3.00	63.75	24	2 3/4	-	-	-	-
228	73.00	57.62	58.496/58.492	.50	58.500/58.504	.62	3.00	67.75	24	2 3/4	-	-	-	-
230	77.00	61.62	62.496/62.492	.50	62.500/62.504	.62	3.00	71.75	24	2 3/4	-	-	-	-

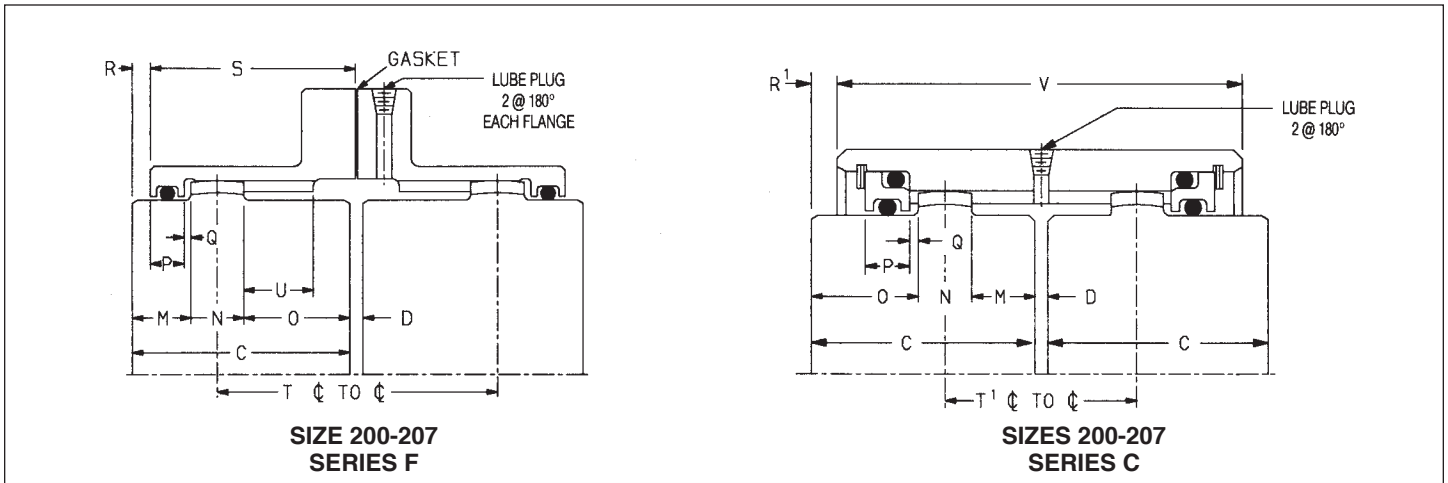
SIZES 201¹/₂-205¹/₂ HAVE SHROUDED BOLTS (SB) WITH SELF-LOCKING NUTS AS STANDARD; EXPOSED BOLTS (EB) UPON REQUEST.
 SIZES 206-207 HAVE EXPOSED BOLTS (EB) WITH SELF-LOCKING NUTS AS STANDARD.
 SIZES 208-230 HAVE EXPOSED BOLTS (EB) WITH NUTS AND LOCKWASHERS.
 NON-STANDARD BOLT CIRCLES CAN BE MADE.

Amerigear

Flexible Couplings

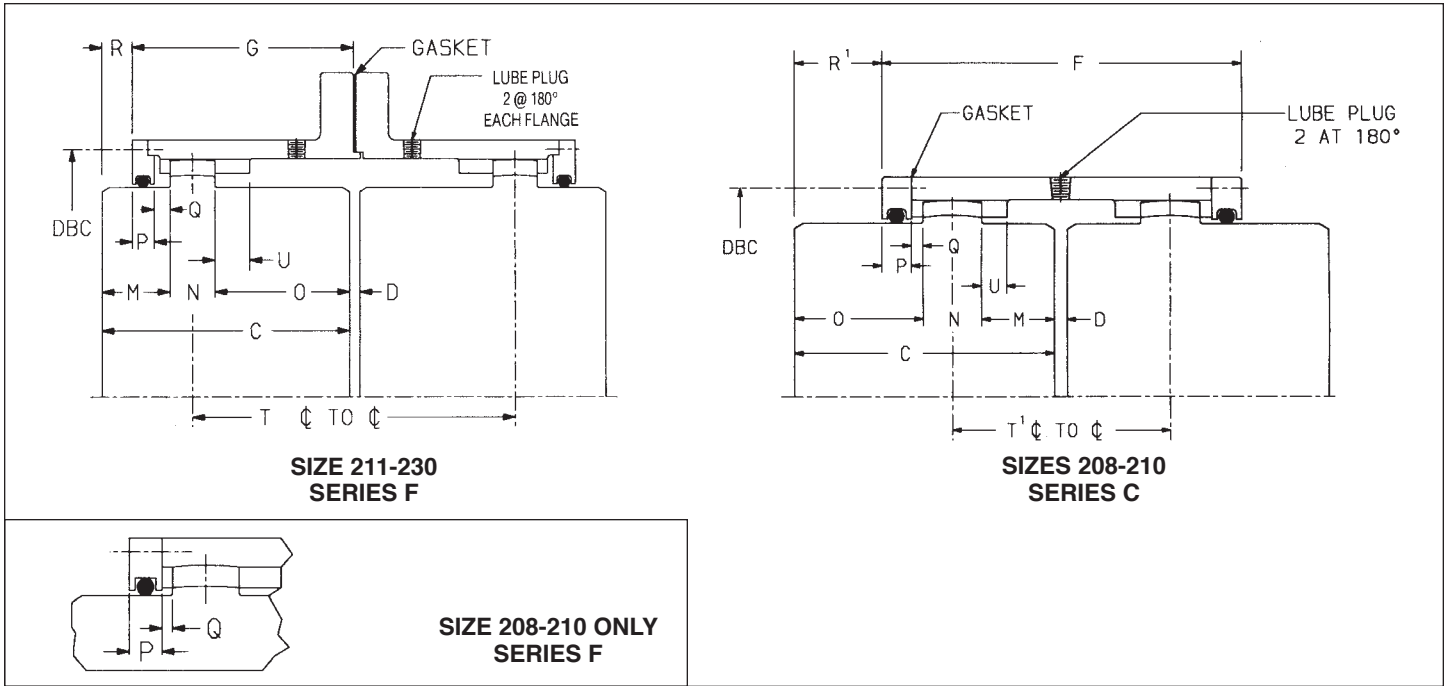
Additional Dimensions

Series F and C



Size	SERIES F								SERIES C							
	C	D	M	N	O	P	Q	R	S	T	U	Lube Plug Size and Thread NPTF	R'	T'	V	Lube Plug Size and Thread NPTF
F200	1.06	.12	.53	.31	.22	.31	.03	.19	.92	.88	.44	1/8-27	—	—	—	—
C200	1.06	.12	.22	.31	.53	.31	.03	—	—	—	—	—	—	.88	2.25	—
201	1.38	.12	.45	.38	.55	.31	.05	.09	1.36	1.59	.24	1/8-27	—	1.41	2.88	—
201 1/4	1.69	.12	.47	.38	.84	.31	.06	.09	1.64	2.19	.50	1/16-27	.28	1.44	2.94	1/16-27
201 1/2	1.94	.12	.62	.53	.78	.31	.08	.23	1.77	2.22	.28	1/8-27	.22	1.89	3.56	1/8-27
202	2.44	.12	.69	.62	1.12	.38	.08	.23	2.27	3.00	.62	1/8-27	.47	2.12	4.06	1/8-27
202 1/2	3.03	.19	.80	.75	1.48	.38	.09	.31	2.81	3.91	.89	1/4-18	.81	2.54	4.62	1/8-27
203	3.59	.19	.97	.88	1.75	.56	.11	.30	3.39	4.56	1.16	1/4-18	.89	3.01	5.59	1/8-27
203 1/2	4.19	.25	1.09	1.00	2.09	.56	.12	.41	3.91	5.44	1.41	1/4-18	1.10	3.43	6.43	1/8-27
204	4.75	.25	1.19	1.12	2.44	.62	.14	.41	4.46	6.25	1.75	1/4-18	1.35	3.75	7.06	1/8-27
204 1/2	5.31	.31	1.27	1.25	2.80	.62	.16	.48	4.98	7.16	1.80	1/4-18	1.68	4.10	7.58	1/4-18
205	6.03	.31	1.33	1.38	3.33	.62	.19	.52	5.67	8.34	2.23	1/4-18	2.18	4.35	8.01	1/4-18
205 1/2	6.62	.31	1.34	1.50	3.78	.62	.19	.53	6.25	9.38	2.72	1/4-18	2.64	4.49	8.28	1/4-18
206	7.41	.31	1.50	1.62	4.28	.62	.22	.67	6.89	10.50	2.94	1/4-18	3.11	4.93	8.91	1/4-18
207	8.69	.38	2.00	1.75	4.94	.62	.31	1.06	7.81	12.00	3.09	1/4-18	3.66	6.13	10.44	1/4-18

Additional Dimensions Series F and C



Size	C	D	M	N	O	P	Q	U	D.B.C.	SEAL RETAINER		SERIES F			SERIES C		
										No.	Size	G	R	T	F	R'	T'
208	9.75	.38	2.78	1.75	5.22	.88	.34	2.81	17.72	20	3/8-16	8.38	1.56	12.56	11.88	4.00	7.69
209	10.75	.50	3.09	2.00	5.66	.88	.41	3.06	19.81	24	3/8-16	9.19	1.81	13.81	13.25	4.38	8.68
210	12.00	.50	3.53	2.12	6.34	.88	.41	3.25	21.50	16	1/2-13	10.00	2.25	15.31	14.38	5.06	9.68
211	13.00	.50	3.81	2.38	6.81	1.00	.44	.75	23.75	16	1/2-13	10.88	2.38	16.50	—	—	—
212	14.00	.50	4.19	2.62	7.19	1.00	.50	.94	25.75	18	1/2-13	11.56	2.69	17.50	—	—	—
213	15.00	.75	4.44	2.88	7.69	1.00	.50	1.19	27.75	18	1/2-13	12.44	2.94	19.00	—	—	—
214	16.00	.75	4.81	3.12	8.06	1.00	.50	1.19	29.75	18	1/2-13	13.06	3.31	20.00	—	—	—
215	17.00	.75	5.25	3.25	8.50	1.00	.57	1.25	31.75	20	1/2-13	13.69	3.69	21.00	—	—	—
216	18.00	1.00	9.06	3.38	5.56	1.31	.59	1.38	34.25	20	3/4-10	11.31	7.19	15.50	—	—	—
218	20.00	1.00	11.00	3.50	5.50	1.31	.66	1.50	38.25	24	3/4-10	11.44	9.06	15.50	—	—	—
220	22.00	1.00	12.94	3.62	5.44	1.31	.72	1.50	42.25	24	3/4-10	11.56	10.94	15.50	—	—	—
222	24.00	1.00	14.88	3.75	5.38	1.38	.75	1.56	46.50	30	3/4-10	11.72	12.78	15.50	—	—	—
224	26.00	1.00	16.75	4.00	5.25	1.38	.78	1.56	50.50	30	3/4-10	11.88	14.62	15.50	—	—	—
226	28.00	1.00	18.50	4.50	5.00	1.38	.84	1.75	55.50	36	3/4-10	12.19	16.31	15.50	—	—	—
228	30.00	1.00	20.25	5.00	4.75	1.38	1.06	2.00	59.50	36	3/4-10	12.69	17.81	15.50	—	—	—
230	32.00	1.00	22.25	5.00	4.75	1.38	1.06	2.00	63.50	36	3/4-10	12.69	19.81	15.50	—	—	—

Amerigear 200 Series

Flexible Couplings

Alignment and Installation Instructions

Purpose: The purpose of aligning equipment is to avoid transmission of unwanted stresses to bearings, shafts, couplings, etc.

How: By providing minimum angularity and offset of shaft axis at normal operating conditions (Figs. 1 and 2).

Why: To increase life of bearings, couplings, shafts and seals. To get at the root of serious malfunctions involving shutdowns and costly repairs.

When:

1. During installation, before grouting.
2. Immediately after initial operation.
3. When final operating conditions and final temperature are attained.
4. Seasonally.
5. Whenever first symptoms of trouble occur — vibration, undue noise, sudden overheating of bearings.

Practical Considerations:

1. Verify shaft separation.
2. Locate rotor in running position (for example, on sleeve bearing motors).
3. Anticipate thermal changes.
4. Read instructions and review drawings.

Tools:

1. Dial indicator with attaching device.
2. Feeler gauges.
3. Inside micrometer.
4. Outside micrometer.
5. Snap gauges.
6. Straightedge.

Angular Misalignment Measurement:

1. Measure at 4 points the space between the shaft ends (Fig. 3).
2. Rotate both shafts 180° and repeat.
3. Perform calculations for angle.

Offset Misalignment Measurement:

1. Rotate shaft A (with dial indicator mounted) and note readings of shaft B offset (Fig. 4).
2. Or use straightedge and feeler gauge (Fig. 5).

CAUTION: Misalignment at installation should not exceed 1/3 of rated catalog misalignment.

CAUTION: Rotating equipment is potentially dangerous and could cause injury or damage if not properly protected. Follow applicable codes and regulations.

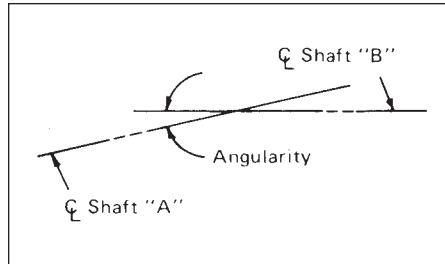


Figure 1 — Angularity is the acute angle formed at the intersection of the axes of the driving and the driven machine shafts. When shafts are exactly parallel, angular misalignment is zero; but vertical or horizontal displacement of axes may be present (See Fig. 2).

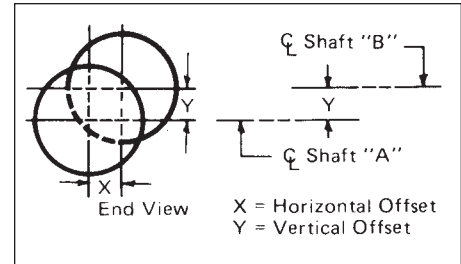


Figure 2 — Concentric alignment (also called offset alignment or parallel offset) is the relationship between the shaft axes in terms of vertical and horizontal displacements of the axis of one shaft from the axis of the other shaft.

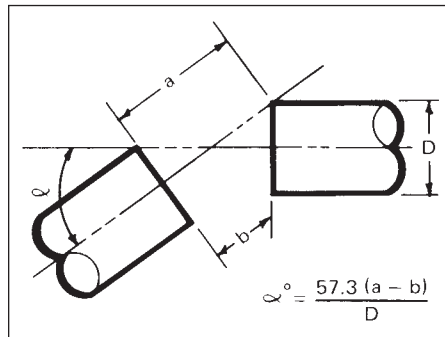


Figure 3 — To determine relative angular shaft-positions of driving and driven machines, measure at four points the space between the shaft ends. Choose the largest (a) and smallest dimension (b).

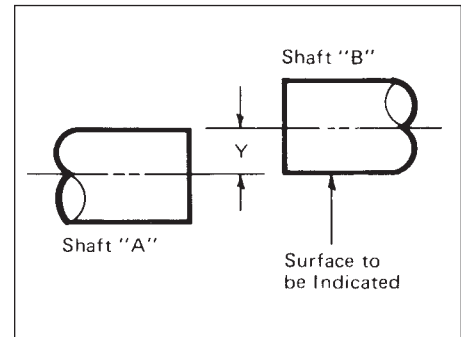


Figure 4 — To measure offsets with a dial indicator, attach the indicator to shaft "A," rotate shaft, and indicate to the periphery of shaft "B." To obtain actual displacements of shafts, divide dial indicator readings by 2.

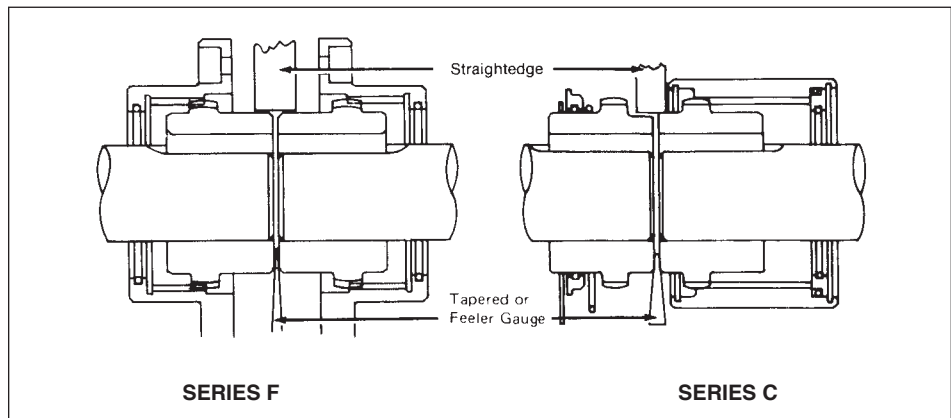
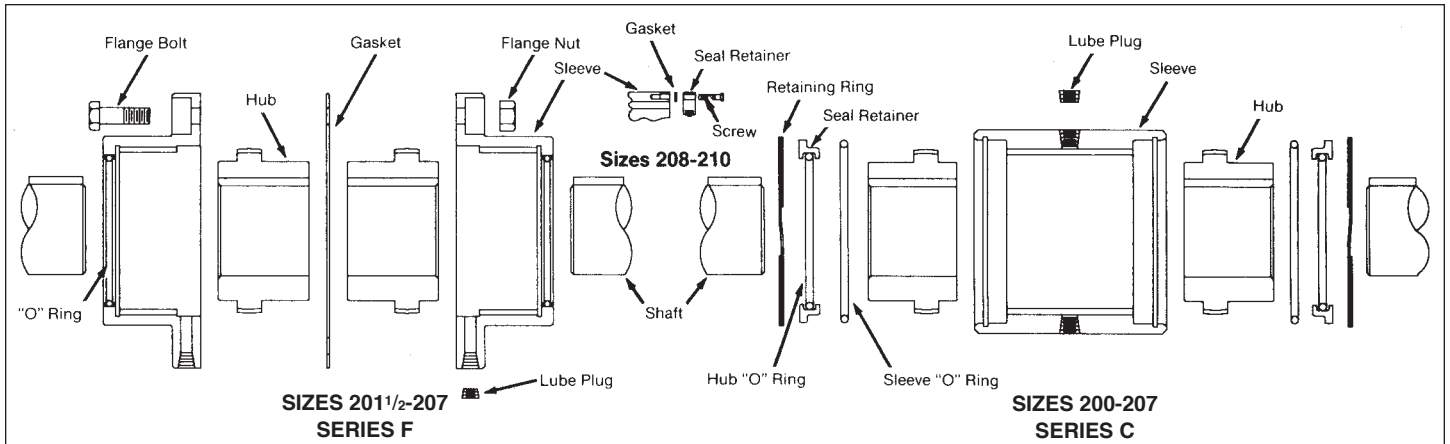


Figure 5 — Lay straightedge on one hub and measure gap between straightedge and other hub with feeler gauge. Measure at top, bottom, and both sides. Feeler gauge readings indicate actual displacements of shafts.

Installation and Lubrication Instructions



Installation

Disassemble coupling and clean all parts. Follow the appropriate 6 steps below and you are ready to go! Installed and lubricated in accordance with the instructions, your Amerigear 200 Series coupling is prepared for a life of dependable, trouble-free service.

Series F Installation

Step 1. Lightly coat grease on “O” rings and insert “O” rings into grooves of sleeve (into grooves of seal retainer for sizes 208 and larger). Place sleeves for sizes 200-207 over shaft ends. For sizes 208 and larger, place only the seal retainers with “O” rings inserted, on shaft. Care should be taken not to damage seal on shaft key seat.

Step 2. Check key fits and coat keys and keyways with oil resistant sealing compound (Permatex No. 2) to prevent leakage. Install size 201 to 207 hubs on shafts with long ends flush with shaft ends. Install size 200 hub on shaft with short end flush with shaft end. For shrink fits, apply heat to hubs uniformly, preferably submerged in oil not exceeding 350° F. Do not allow “O” ring seals to contact heated hubs.

CAUTION: Care must be taken to avoid personal injury in the heating and handling of coupling hubs that are shrink fit shaft mounted.

For sizes 208 and larger, place retainer gaskets and sleeves over hubs and onto shafts.

Step 3. Align shafts allowing clearance as per tabulation or in accordance with Dimension “D” from Engineering Data. Check gap with taper or feeler gauge at 90° points and align hubs with straightedge at 90° points.

Step 4. After thoroughly coating hub and sleeve teeth with lubricant, slip sleeves onto

hubs, carefully engaging teeth (do not damage seal surface). Place sleeve gasket between sleeves and align bolt holes.

Step 5. Secure sleeves, using care to tighten fasteners uniformly. See tabulation “Flange Bolt Tightening Torque.” For sizes 208 and larger, bolt seal retainers to sleeves.

Step 6. Remove both Dryseal lube plugs and add grease in the amount given in the Lubricant Quantity Table. Install lube plugs using Permatex No. 2 for sealing and seat securely.

Series C Installation

Step 1. For sizes 200-207 place retainer ring, seal retainer with “O” ring seated in retainer groove, and sleeve “O” ring on each shaft. For sizes 208 and larger, place seal retainer with “O” ring inserted, and gasket over shaft. For CS Series, place retainer ring on shaft on which CS rigid hub will be mounted.

Step 2. Check key fits and coat keys and keyways with oil resistant compound to prevent leakage. Install hubs on shafts with short ends flush with shaft ends. For shrink fits, apply heat to hubs uniformly, preferably submerged in oil not exceeding 350°F. Do not allow “O” rings to contact heated hubs.

CAUTION: Care must be taken to avoid personal injury in the heating and handling of coupling hubs that are shrink fit shaft mounted.

Step 3. Slip sleeve over hub mounted on longest shaft.

Step 4. Align shafts allowing clearance as per tabulation or from Engineering Data, Dimension “D.” Check gap with taper or feeler gauge at 90° intervals. Also align hubs with straightedge at 90° points.

Step 5. Pack hub and sleeve teeth with grease. Force grease into shaft gap. Lightly coat grease on “O” rings. Slide sleeve over hubs to center position. Remove Dryseal lube plugs and add grease in the amount given in the Lubricant Quantity Table.

Step 6. For sizes 200-207, install sleeve “O” rings in sleeve counterbores — then press seal retainer assembly in place. Use fingertips or blunt tool. Seat retaining rings in grooves using a winding motion. Recheck to assure retaining rings are positively seated. For sizes 208 and larger, bolt seal end plates to sleeves.

SIZE	HUB SEPARATION			FLANGE BOLT TIGHTENING TORQUE FT. LBS.*	
	F & C	FS	CS	F Exposed	F Shrouded
200	.125	.078	.125	10	10
201	.125	.078	.125	10	10
201½	.125	.078	.125	10	10
201½	.125	.156	.125	29	32
202	.125	.156	.125	63	32
202½	.188	.188	.188	125	69
203	.188	.188	.188	125	69
203½	.250	.219	.250	210	133
204	.250	.312	.250	210	133
204½	.312	.344	.312	210	133
205	.312	.344	.312	313	232
205½	.312	.344	.312	313	232
206	.312	.406	.312	313	340
207	.375	.500	.375	440	476
208	.375	.500	—	600	
209	.500	.562	—	800	
210	.500	.625	—	1,200	

*Tightening torque based on unlubricated threads; if threads are lubricated derate torque to 75% of above values.

Amerigear 200 Series

Flexible Couplings

Maintenance and Lubrication

LUBRICANTS

MANUFACTURER	GENERAL	MOIST / WET	HIGH TORQUE	150 – 300°F (65 – 150°C)	CLASS III
American Lubricants Co. (Dayton, OH)	Alubco Bison 1650	Alubco Bison 1650	Alubco Bison 1650	Alubco Bison 1650	Alubco Bison 1650
Brooks Technology (Cleveland, OH) (Fuchs Lubricants)	Superplex EP #1 or Benalene 350 EP #2	Superplex EP #1 or Benalene 350 EP #2	Superplex EP #1 or Benalene 350 EP #2	Superplex EP #1 or Benalene 350 EP #2	–
Chevron Lubricants	Coupling Grease or Duralith EP2	Coupling Grease or Duralith EP2	Coupling Grease or Duralith EP2	Duralith EP2 or Rykon Premium EP#2	Coupling Grease or Gear Compound EP 460
Citgo Petroleum Corp.	Premium Lithium EP2	Premium Lithium EP2	Premium Lithium EP2	Premium Lithium EP2	EP Compound 460 or AP Grease
Exxon / Mobil Corp.	Mobilux EP 111	Mobilux EP 111	Mobilux EP 111	Mobiltemp 78 or Unirex N2	Mobilgrease 28 or Mobilgrease XTC or Teresstic 460
Fiske Bros. Refining Co.	Lubriplate 630AA	Lubriplate 630AA	Lubriplate 630AA	Lubriplate 1200-2	Lubriplate #8 (Gear Oil) ISO 460
Anderol Inc. (Houghton Canada)	Anderol 786	Anderol 786	Anderol 786	Anderol 786	Anderol 786
Kendall Motor Oil	L-424	L-424	–	L-424	L-427 Super Blu
Lyondell Lubricants (Houston, TX)	Litholene H EP2	Litholene H EP2	Litholene H EP2	–	Pennant NL 220
Maryn International / Power Up Lubricants (Calgary, Canada)	Thixogrease EP #2	Thixogrease EP #2	Thixogrease EP #2	Thixogrease EP #2	Thixogrease EP #2
Pennzoil / Quaker State	Pennlith EP711 or Pennlith EP712	Pennlith EP711 or Pennlith EP712	Pennlith EP711 or Pennlith EP712	Pennzoil 707L or Pennlith EP712	Super Maxol EP460
Syn-Tech Ltd. (Addison, IL)	NS-3913-G1	NS-3913-G1	NS-3913-G1	NS-3913-G1	NS-3913-G1
Texaco Inc.	Multifax EP2 or Texaco Coupling Grease	Multifax EP2 or Texaco Coupling Grease	Multifax EP2 or Texaco Coupling Grease	Thermatex EP2	Texaco Coupling Grease
UNOCAL 76 (TOSCO Corporation)	UNOBA EP2	UNOBA EP2	UNOBA EP2	UNOBA EP2	MP Gear Lube 85W-140

For low temp. (-65°), Aeroshell #22 by Shell Oil Co., Anderol 793 by Huls America, Inc. For low speeds, lubricant manufacturer should be consulted.

LUBRICANT QUANTITIES

Coupling Size	LUBRICATION				
	SERIES F*		SERIES C		
	Wt. Lbs.	Vol. Qts.	Wt. Lbs.	Vol. Qts.	
200	.020	.010	.015	.008	
201	.045	.025	.036	.020	
201¼	.069	.033	.045	.025	
201½	.140	.070	.080	.040	
202	.200	.110	.080	.040	
202½	.380	.200	.160	.090	
203	.540	.290	.240	.120	
203½	.820	.430	.240	.120	
204	1.080	.580	.440	.240	
204½	1.540	.820	.540	.290	
205	2.580	1.380	1.000	.530	
205½	3.120	1.660	1.120	.590	
206	3.480	1.860	1.020	.540	
207	7.040	3.760	2.700	1.440	
208	9.160	4.840	5.580	2.970	
209	11.700	6.240	7.620	4.060	
210	14.140	7.540	9.500	5.050	

Maintenance – The Amerigear Coupling requires a minimum of maintenance. Nevertheless, to ensure a trouble-free life a few checks and proper lubrication should be performed at regular intervals.

Ameridrives suggests that the maximum interval between checks and relube be one year. This is only a guide, and the actual interval should be in accordance with good operating practices for application.

To disassemble Series F, remove flange fasteners, separate sleeves, slide sleeves over hubs, clean out old lubricant, and inspect seals and gear teeth. Reassemble, starting with Step 3 under Series F installation instructions on the previous page.

To disassemble Series C, remove one snap ring, slide sleeves off hubs, clean out old lubricant and inspect seals and gear teeth. Reassemble, starting at Step No. 4 under Series C installation instructions on the previous page.

If proper alignment of shafts is assured and it is not practical to disassemble coupling, remove both lube plugs and add grease in sufficient amount to overflow with lubricant holes in horizontal position. Recommended lubricants and quantities are listed on this page.

NOTE: Sizes 200 and 201 Series C are supplied without lube plugs – lubricate per Series C, Step No. 5.

The lubricants listed above are recommended by the lubricant manufacturers for the indicated conditions. Those shaded are reported by lubricant manufacturers to comply with the intent of AGMA 9001. This list is solely for our customers' convenience and does not constitute an endorsement. The listing is not intended to be complete nor necessarily current due to continuous research and improvement by the various manufacturers.

Series F, FM, FA, FE use quantities recommended. For FE, apply one-half in one end and one-half in other end.

Series ES, EMS, FAS use one-half the quantities recommended.

Series C, CM, CA use quantities as shown. Series CS, CMS, CAS use one-half the quantities recommended.

*Series F, Class III use quantities as recommended for Series F but limited to the greases shown in Class III column above or the following oils:

Citgo EP Compound 460 by Citgo Corp.; Teresstic 460 by Exxon; Lubriplate No. 8 by Fiske Bros.

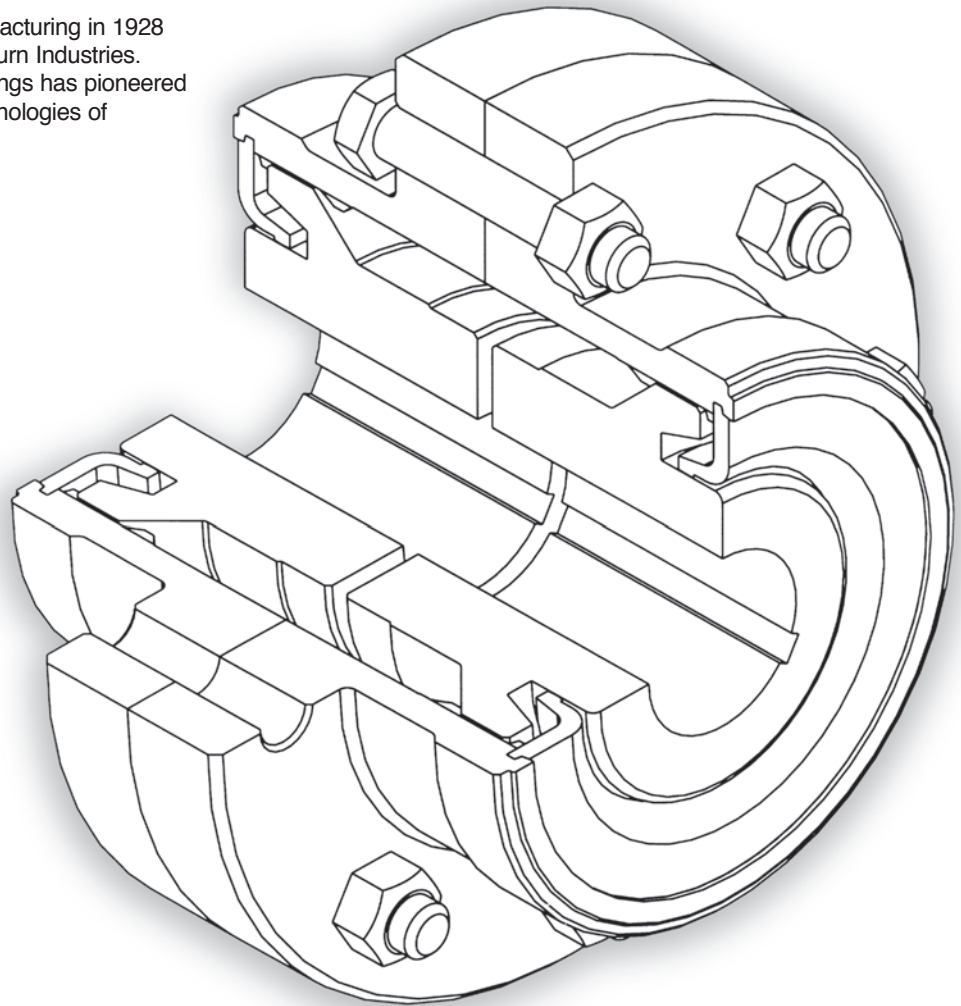
Amerigear

Metal Seal

Flexible Couplings

Ameridrives International began manufacturing in 1928 as the Mechanical Drives Division of Zurn Industries. Through the years, Ameridrives Couplings has pioneered many improvements for changing technologies of power transmission equipment:

- **Ameridrives** patented **Amerigear**[®] fully-crowned gear tooth
- **Amerigear**[®] mill spindles and advanced gear technology
- **Americardan**[®] high capacity universal joints
- **Ameriflex**[®] non-lubricated diaphragm couplings



As a leader in power transmission equipment for over 70 years, Ameridrives Couplings are the single source for all drive applications. Let us solve your Driveline Connections. A flexible coupling must provide three basic functions:

1. Physically couple together two rotating shafts.
2. Compensate for all types of misalignment.
3. Compensate for end or axial movement.

The FAST[®] Coupling was the standard in the metals industry for decades. Ameridrives now offers the labyrinth/steel ring seal option for your coupling.

"Drop-In" Replacement for FAST [®] Coupling			
FAST [®]	Amerigear [®]	FAST [®]	Amerigear [®]
1 ½	1 ½	4 ½	4 ½
2	2	5	5
2 ½	2 ½	5 ½	5 ½
3	3	6	6
3 ½	3 ½	7	7
4	4		

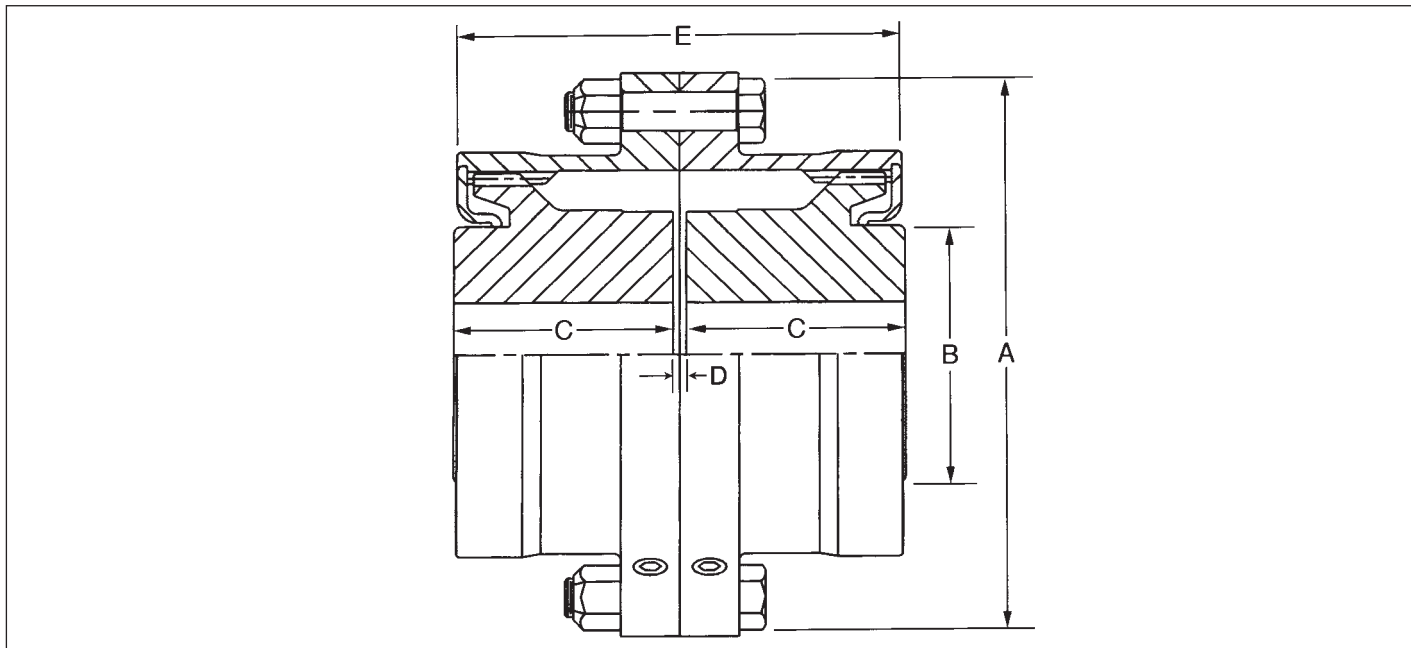
Amerigear

Metal Seal

Full-Flex Couplings

Series F Size 1 1/2 - 7

Series F Full Flex gear coupling with Steel Labyrinth Seal is applicable for harsh environments.



F Size	Max Bore ^① with Standard Key	Load Capacity		Maximum Speed ^③ RPM	Weight with Solid Hubs ^④ lbs.	Dimensions				
		HP/100 RPM	Torque In-Lbs. ^② x 10 ³			A	B	C	D	E
1 1/2	1.63	27	17.0	12,000	16.5	6.00	2.19	1.94	.13	4.00
2	2.13	50	31.5	9,300	27.4	7.00	2.88	2.44	.13	4.94
2 1/2	2.75	90	56.7	7,900	48.0	8.38	3.63	3.03	.19	6.19
3	3.13	160	101.0	6,800	70.8	9.44	4.25	3.59	.19	7.31
3 1/2	3.75	235	148.0	6,000	113.0	11.00	5.00	4.19	.25	8.50
4	4.25	375	236.0	5,260	177.0	12.50	5.75	4.75	.25	9.75
4 1/2	4.75	505	318.0	4,770	231.0	13.63	6.50	5.31	.31	10.94
5	5.50	700	441.0	4,300	351.0	15.31	7.31	6.03	.31	12.06
5 1/2	5.88	920	580.0	3,880	435.0	16.75	8.00	6.91	.31	13.81
6	6.50	1,205	759.0	3,600	538.0	18.00	8.81	7.41	.31	14.81
7	8.00	1,840	1,160.0	3,000	860.0	20.75	10.31	8.69	.38	17.31

① BORE SIZES ABOVE MAXIMUM CONTACT AMERIDRIVES.

② OCCASIONAL PEAK TORQUES SHOULD NOT EXCEED 2X THE TORQUE CAPACITY SHOWN.

③ MAXIMUM SPEED WITHOUT BALANCING 60% OF VALUES SHOWN. CONSULT AMERIDRIVES FOR HIGHER SPEEDS.

④ WEIGHTS ARE APPROXIMATE.

- OUTER END OF HUB EXTENDS BEYOND SLEEVE IN SIZES 5 1/2, 6 AND 7.
- ALL DIMENSIONS IN INCHES
- ± 1/2° STATIC MISALIGNMENT PER COUPLING HALF.

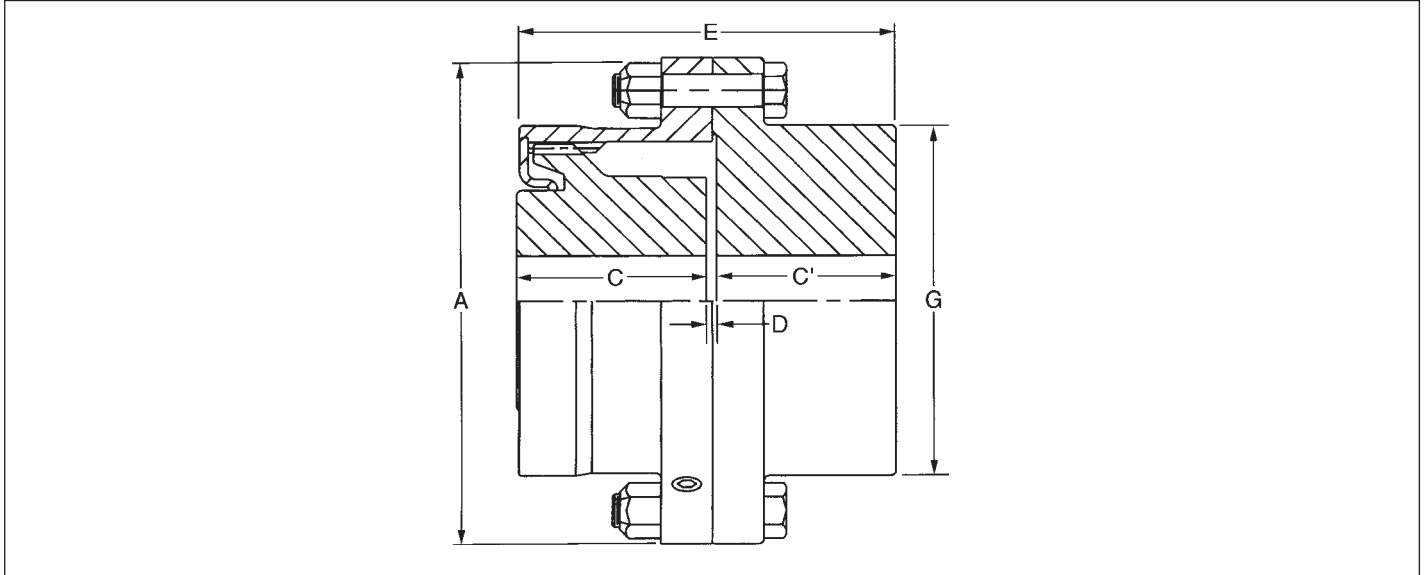
Amerigear

Metal Seal

Flex-Rigid Couplings

Series FS Size 1 1/2 - 7

Series FS Flex-Rigid coupling with Steel Labyrinth Seal is applicable for harsh environments.



FS Size	Max Bore with Standard Keyway		Load Capacity		Maximum Speed ^③ RPM	Weight with Solid Hubs ^④ lbs.	Dimensions					
	^① Flex Half	^① Rigid Half	HP/100 RPM	Torque In-Lbs. ^② x 10 ³			A	C	C'	D ^⑤	E	G
1 1/2	1.63	2.69	27	17.0	12,000	17.7	6.00	1.94	1.84	.16	3.94	3.81
2	2.13	3.38	50	31.5	9,300	30.0	7.00	2.44	2.28	.16	4.84	4.81
2 1/2	2.75	4.00	90	56.7	7,900	52.6	8.38	3.03	2.91	.19	6.28	5.75
3	3.13	4.75	160	101.0	6,800	78.8	9.44	3.59	3.46	.19	7.22	6.75
3 1/2	3.75	5.50	235	148.0	6,000	124.0	11.00	4.19	4.03	.22	8.38	7.75
4	4.25	6.38	375	236.0	5,260	187.0	12.50	4.75	4.44	.31	9.50	9.00
4 1/2	4.75	7.25	505	318.0	4,770	250.0	13.63	5.31	5.06	.34	10.72	10.12
5	5.50	8.50	700	441.0	4,300	377.0	15.31	6.03	5.69	.34	11.91	11.38
5 1/2	5.88	8.00	920	580.0	3,800	470.0	16.75	6.91	6.97	.34	14.06	10.75
6	6.50	8.75	1,205	759.0	3,600	606.0	18.00	7.41	7.46	.34	15.06	11.50
7	8.00	10.00	1,840	1,160.0	3,000	957.0	20.75	8.69	8.75	.44	17.66	13.38

① BORE SIZES ABOVE MAXIMUM CONTACT AMERIDRIVES.

② OCCASIONAL PEAK TORQUES SHOULD NOT EXCEED 2X THE TORQUE CAPACITY SHOWN.

③ MAXIMUM SPEED WITHOUT BALANCING 60% OF VALUES SHOWN. CONSULT AMERIDRIVES FOR MAXIMUM SPEEDS OF FLOATING SHAFT COUPLINGS AND LATERAL CRITICAL SPEED CONSIDERATIONS. USERS MUST VERIFY THAT THE DESIGN OF THE SHAFT TO COUPLING HUB CONNECTION IS ACCEPTABLE FOR THE DUTY INTENDED.

④ WEIGHTS ARE APPROXIMATE.

⑤ FLOATING SHAFT LENGTH IS EQUAL TO THE SHAFT SEPERATION MINUS 2 TIMES THE "D" DIMENSION.

• OUTER END OF HUB EXTENDS BEYOND SLEEVE IN SIZES 5 1/2 , 6 AND 7.

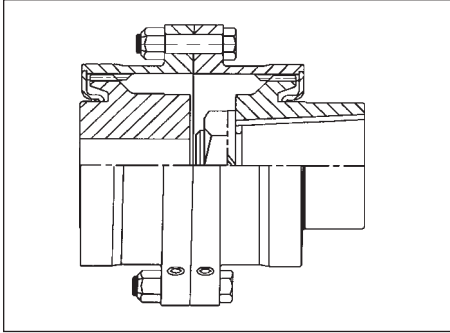
• ALL DIMENSIONS IN INCHES

• ± 1/2 ° STATIC MISALIGNMENT PER COUPLING HALF.

Amerigear

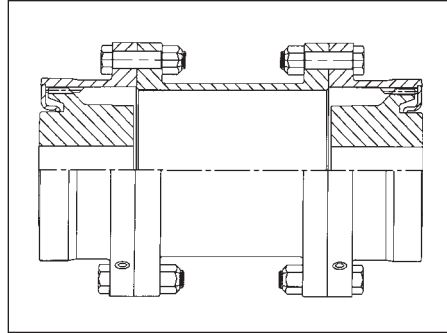
Metal Seal

Modifications & Variations



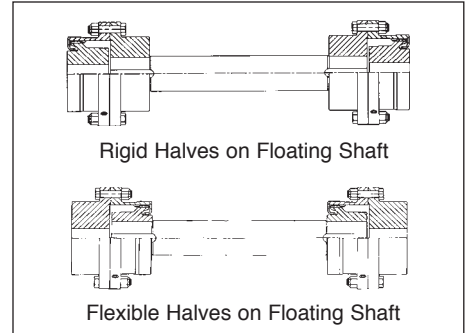
Mill Motor Couplings

Designed for modern mill motor applications and standards demanding quick change-out of equipment for continuous and uninterrupted operation.



Spacer Couplings

Commonly used on pump and compressor drives where maintenance or replacement of shaft seals or bearings is accomplished without moving connected equipment.



Tandem Couplings

Two flex rigid couplings connected by an intermediate floating shaft comprise a tandem assembly.

Selection Information

1. **Obtain Shaft Sizes.** Compare shaft sizes of driving and driven equipment with listed maximum bores of desired Series of Type coupling to determine "tentative" coupling size.

2. **Compute effective HP/100 RPM or torque to be transmitted.** Select a service factor from adjacent table. Determine HP/100 RPM as follows:

$$\text{HP/100 RPM (effective)} = \frac{\text{HP transmitted} \times 100 \times \text{S.F.}}{\text{RPM}}$$

or determine Torque (in.-lbs.) as follows:

$$\text{Torque (effective)} = \frac{\text{HP (effective)} \times 630}{\text{RPM}}$$

or

$$\text{Torque (effective)} = \frac{\text{HP transmitted} \times 63,000 \times \text{S.F.}}{\text{RPM}}$$

Confirm "Tentative" coupling size or increase to a size which has a HP/100 RPM or torque rating equal to or greater than value computed above

3. **Check Maximum Speed of Application.** The listed speeds are given only as a guide, since the maximum speed depends on the system characteristics.

4. **Check Space Limitations** Dimensions of the selected coupling should be compared with space provide in the application to assure proper clearances. Shaft extensions, separations, and clearances to align coupling should be checked.

Recommended Service Factors (S.F.)

In order to provide for the dynamic torque which must be transmitted, it may be necessary to increase the horsepower to be transmitted by a factor which will allow for momentary increases in torque due to the characteristics of the equipment. The service factors shown in the table provide a basis for estimating this allowance for specific combination of connected equipment.

These factors are derived from lengthy service experience with average applications — and they are to be considered as a general guide. For conditions not covered by the table, good judgment must be exercised and a factor selected by referring to the type of equipment most closely approximating the type of application.

LOAD	DRIVEN EQUIPMENT	TYPE DRIVER		
		Motor or Turbine	Hydraulic Drive	Reciprocating Engine
UNIFORM	Centrifugal Pumps • Conveyors - Even Loaded • Exciters • Fans and Blowers - Light Duty • Generators- Even Loaded • Mixers - Liquid	1.0	1.25	1.5
LIGHT SHOCK	Centrifugal Pumps • Generators - Pulsating Load • Grinders • Hydraulic Pumps • Kilns • Line Shafting • Machine Tools • Oscillating Pumps • Textile Machinery • Woodworking Machinery	1.5	1.75	2.0
MEDIUM SHOCK	Air Compressors - Multi-Cylinder • Bail and Rod Mills • Cranes • Elevators • Hoists • Punch Presses • Reciprocating Pumps • Shears • Ship Drives • Welding Generators	2.0	2.25	2.5
HEAVY SHOCK	Air Compressors - Single Cylinder • Dredges • Drilling Rigs • Mine Machinery • Rolling Mill Drives • Rubber Mixers	2.5	2.75	3.0
EXTREME SHOCK	Ore Crushers • Barstock Shears • Vibrating Conveyors	3.0	3.5	4.0

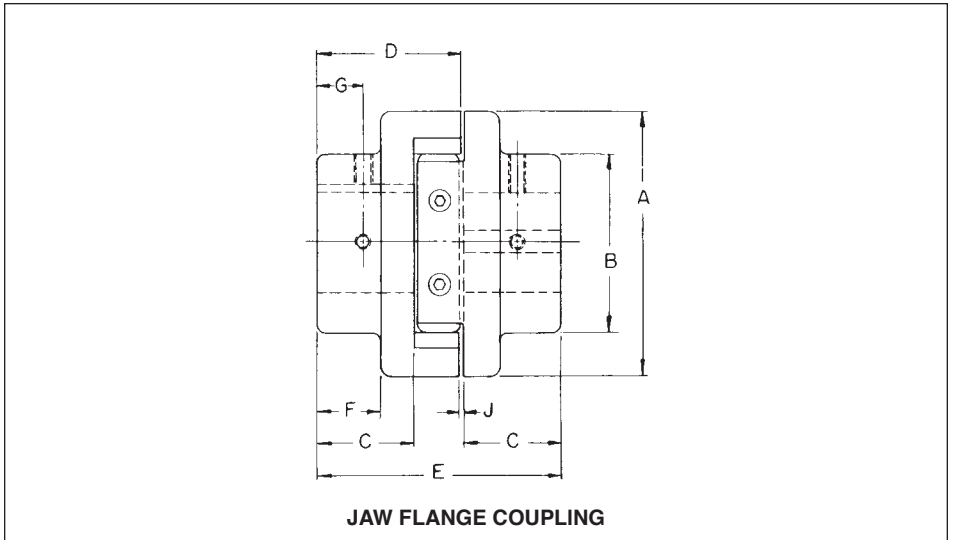
American

Flexible Couplings

Jaw Flange Couplings Sizes 3-13

Application: Meets requirements of standard medium duty applications for shaft sizes up to 3 $\frac{3}{8}$ ". Compensates for all three types of misalignments and is particularly suitable for vertical or blind assembly installation.

Description: The American coupling consists of three basic parts - two identical jaw flanges and a floating center member. The jaw flanges are positioned at right angles to each other and engage opposite parallel surfaces of the center member as shown by the cutaway view on page 5. American flexible couplings are normally furnished bored for a clearance or push fit on the shafts as specified, and with a standard keyway (when specified) in each bore and two setscrews for each hub. (Sizes 3, 4, and 6 have **one** setscrew.)



Cplg. Size	Nominal Max. Bore In.	Absolute Max. Bore* In.	Max. Distance Bottom of Keyway to Bore Axis* In.	Max. Speed RPM	Load Capacity HP Per 100 RPM	Parallel Onset Capacity In.	DIMENSIONS									Weights (Lbs.) Solid Cplg.
							A	B	C	D	E	F	G	H**	J	
3	.50	.50	.34	3,600	.05	.031	1.62	1.00	.75	1.25	2.03	.56	.37	—	.03	.48
4	.75	.75	.50	3,600	.09	.062	1.87	1.37	.75	1.25	2.03	.53	.37	—	.03	.70
6	1.00	1.00	.62	3,600	.16	.062	2.62	1.87	1.12	1.75	2.91	.78	.50	—	.03	1.80
8	1.25	1.37	.87	6,300	2.20	.094	3.00	2.37	1.37	2.12	3.56	.87	.50	1.25	.06	6.00
8 $\frac{1}{2}$	1.37	1.62	1.00	5,300	4.20	.094	3.75	2.62	1.50	2.37	3.94	.87	.50	1.50	.06	9.80
9	1.75	2.00	1.25	5,000	6.00	.094	4.12	3.12	1.75	2.75	4.56	1.00	.62	1.56	.06	14.20
10	2.00	2.25	1.37	4,160	10.80	.156	5.25	3.62	2.25	3.37	5.69	1.37	1.00	2.12	.06	15.50
11	2.25	2.50	1.56	3,670	14.00	.156	6.00	4.12	2.50	3.75	6.31	1.50	1.00	1.94	.06	37.00
12	2.62	3.00	1.75	2,770	21.00	.281	7.50	4.87	2.75	4.25	7.06	1.62	1.00	2.75	.06	64.00
13	3.12	3.62	2.12	2,250	30.00	.281	9.00	5.75	3.00	4.75	7.81	1.75	1.25	3.50	.06	115.00

* ABSOLUTE MAXIMUM BORE MAY BE USED PROVIDING THE MAXIMUM DISTANCE, BOTTOM OF KEYWAY TO BORE AXIS, IS NOT EXCEEDED.

**DIAMETER OF SHAFT CLEARANCE HOLE IN FLOATING CENTER MEMBER.

All Customer Service phone numbers shown in bold

Warner Electric

Electromagnetic Clutches and Brakes

South Beloit, IL - USA
1-800-825-6544

For application assistance:
1-800-825-9050

Electromagnetic Clutches and Brakes

St Barthelemy d'Anjou, France
+33 (0) 2 41 21 24 76

Precision Electric Coils and Electromagnetic Clutches and Brakes

Columbia City, IN - USA
1-260-244-6183

Inertia Dynamics

Spring Set Brakes; Power On and Wrap Spring Clutch/Brakes

New Hartford, CT - USA
1-800-800-6445

Matrix International

Electromagnetic Clutches and Brakes, Pressure Operated Clutches and Brakes

Brechin, Scotland
+44 (0) 1356 602000

South Beloit, IL - USA
1-815-389-3771

Warner Linear

Linear Actuators and Guideways

Belvidere, IL - USA
1-800-825-6544

For application assistance:
1-800-825-9050

Twiflex Limited

Caliper Brakes and Thrusters

Twickenham, England
+44 (0) 20 8894 1161

Kilian Manufacturing

Engineered Bearing Assemblies

Syracuse, NY - USA
1-315-432-0700

TB Wood's

Belted Drives and Elastomeric Couplings

Chambersburg, PA - USA
1-888-829-6637 – Press #5

For application assistance:
1-888-829-6637 – Press #7

General Purpose Disc Couplings

San Marcos, TX - USA
1-512-353-4000

Wichita Clutch

Pneumatic Clutches and Brakes

Wichita Falls, TX - USA
1-800-964-3262

Pneumatic Clutches and Brakes

Bedford, England
+44 (0) 1234 350311

Industrial Clutch

Pneumatic and Oil Immersed Clutches and Brakes

Waukesha, WI - USA
1-262-547-3357

Formsprag Clutch

Overrunning Clutches and Holdbacks

Warren, MI - USA
1-800-348-0881 – Press #1

For application assistance:
1-800-348-0881 – Press #2

Marland Clutch

Roller Ramp and Sprag Type Overrunning Clutches and Backstops

Burr Ridge, IL - USA
1-800-216-3515

Stieber Clutch

Overrunning Clutches and Holdbacks

Heidelberg, Germany
+49 (0) 6221 30 47 0

Boston Gear

Enclosed and Open Gearing, Electrical and Mechanical P.T. Components

Charlotte, NC - USA
1-800-825-6544

For application assistance:
1-800-816-5608

Huco Dynatork

Precision Couplings and Air Motors

Hertford, England
+44 (0) 1992 501900

USA
1-800-825-6544

Ameridrives Couplings

Mill Spindles, Ameriflex, Ameridisc

Erie, PA - USA
1-814-480-5000

Gear Couplings

San Marcos, TX - USA
1-512-353-4000

Ameridrives Power Transmission

Universal Joints, Drive Shafts, Mill Gear Couplings

Green Bay, WI - USA
1-920-593-2444

Bibby Transmissions

Disc, Gear, Grid Couplings, Overload Clutches

Dewsbury, England
+44 (0) 1924 460801

Boksburg, South Africa
+27 11 918 4270

Nuttall Gear and Delroyd Worm Gear

Worm Gear and Helical Speed Reducers

Niagara Falls, NY - USA
1-716-298-4100

Saftek Friction

Non-asbestos Brake and Clutch Materials

Telford, England
+44 (0) 1952 581122

Asia Pacific Sales Offices

Australia

+61 2 9894 0133

China - Beijing

+86 (10) 6053-9884

China - Hong Kong

+852 2615 9313

China - Shanghai

+86 21 5169-9255

China - Taiwan

+886 2 2577 8156

Singapore

+65 6487 4464

Thailand

+66 2 322 5527



Ameridrives Couplings

1802 Pittsburgh Avenue • Erie, PA 16512
814-480-5000 • Fax: 814-453-5891
Email: info@ameridrives.com