

RELIABLE | PRECISE | COMPACT



PRECISION COUPLINGS

EXACT AND BACKLASH FREE FOR PRECISION SERVO AND STEPPER DRIVE APPLICATIONS.

WWW.RW-AMERICA.COM

THE COUPLING.

WHO WE ARE.

ABOVE ALL R+W IS: THE PERFECT COUPLING.

When R+W Antriebs Elemente GmbH was first established in 1990 in Klingenberg, Germany, there were three people on board. The head office is still there, but we are now more than 170 people, with subsidiaries in the USA, China, Italy, Singapore, France and Slovakia, and are partnered with over 60 well established distributors in more than 40 countries throughout the world. Many developments have led to this success, but most importantly it was brought about by our endless search for the best possible coupling solutions as well as the high esteem in which we hold all of our customers.

WE PROVIDE INSPIRED SOLUTIONS BACKED BY SOUND PLANNING AND DESIGN.

R+W stands for expertise in the development of solutions for precise torque transmission. The focus of our development is on innovative coupling systems for all sectors of precision drive technology. As a leading manufacturer of precision couplings and line shafts, we strive to maintain a permanent status of technology leadership in our field. Our central claim: R+W couplings ensure precision for process reliability and efficiency, and to that end we seek perfection.

Optimized for technology and business, our product portfolio includes:

- ▶ **Bellows couplings**
- ▶ **Elastomer insert couplings**
- ▶ **Ball-detent safety couplings**
- ▶ **Line shaft couplings**
- ▶ **High torque industrial couplings**
- ▶ **Development of customized solutions with collaboration from start to finish, including:**
 - Consultation
 - Conception
 - Engineering analysis
 - Prototyping
 - Manufacturing

DRIVE

D - DYNAMIC

Our staff is trained to always be ready and willing to provide a quick reaction to customer inquiries. Our product, the core of which is based on handling high performance, dynamic applications, is increasingly available for fast delivery.

R - RELIABLE

Many of our products are designed for infinite life with zero maintenance required. With thorough engineering processes in place, and an ISO 9001:2008 certified production facility, we continue to deliver high quality coupling products with a high level of reliability.

I - INNOVATIVE

Our business was founded on developing unique and innovative solutions to common coupling problems. Our staff in turn is constantly developing its work flows to streamline delivery and simplify the process for our customers.

V - VERSATILE

With products successfully applied and deployed in over 125 industry segments, chances are very good that we have an expert on our versatile staff that is familiar with your application requirements.

E - EXPANDING

With double digit annual growth the norm, our company is ever expanding, adding new product offerings and opening new service centers throughout the world all the time.

OTHER R+W COUPLINGS

Aside from the products detailed in this catalog, we also offer quality shaft couplings and torque limiters for high powered industrial drives.

More information on these can be found in our **industrial couplings catalog**.

APPLICATIONS AND DESIGN FEATURES

PRECISION COUPLINGS

SIZING AND SELECTION

P. 9

INSTALLATION AND HANDLING

P. 21

TORSIONALLY STIFF BELLOWS COUPLINGS

BK

P. 29

SIZES FROM 2 – 10,000 Nm

AREAS OF APPLICATION

for highly dynamic motion in:

- ▶ Machine tools
- ▶ Test stands
- ▶ Packaging machinery
- ▶ Printing machinery
- ▶ Paper converting machinery
- ▶ Labeling machinery
- ▶ Textile machinery
- ▶ Sorting machinery
- ▶ Automation equipment

FEATURES

- ▶ torsionally stiff
- ▶ low moment of inertia
- ▶ zero backlash
- ▶ highly concentric
- ▶ naturally very well balanced
- ▶ precise transmission
- ▶ infinite life
- ▶ wear and maintenance free
- ▶ easy to install

TORSIONALLY STIFF MINIATURE BELLOWS COUPLINGS

MK

P. 49

SIZES FROM 0.05 – 10 Nm

AREAS OF APPLICATION

for precise transmission of angular motion and torque in:

- ▶ Linear actuators
- ▶ Semiconductor machinery
- ▶ Medical devices
- ▶ Lab automation systems
- ▶ Micro pumps
- ▶ Test and measurement systems

FEATURES

- ▶ zero backlash
- ▶ torsionally stiff
- ▶ precise transmission
- ▶ infinite life
- ▶ easy to install

BACKLASH FREE SERVOMAX® ELASTOMER COUPLINGS



P. 63

SIZES FROM 0.5 – 25,000 Nm

AREAS OF APPLICATION

for vibration damping torque transmission in:

- ▶ Packaging machinery
- ▶ Pump drives
- ▶ Machine tools
- ▶ Lift systems
- ▶ Conveyors
- ▶ Labeling machinery
- ▶ Food processing machinery

FEATURES

- ▶ vibration damping
- ▶ electrically isolating
- ▶ backlash free
- ▶ calibrated preloaded insert
- ▶ concentrically machined hubs

BACKLASH FREE SAFETY COUPLINGS



P. 81

SIZES FROM 0.1 – 2,800 Nm

AREAS OF APPLICATION

for overload protection in:

- ▶ Machine tools
- ▶ Packaging machinery
- ▶ Conveyors and feeders
- ▶ Metal forming equipment
- ▶ Test stands
- ▶ Pump drives
- ▶ Assembly systems
- ▶ Converting equipment
- ▶ Wherever rotation and overload exist

FEATURES

- ▶ protects from rotating inertia as well as motor torque
- ▶ precise torque overload protection
- ▶ patented preload for zero backlash
- ▶ compact simple design
- ▶ low moment of inertia
- ▶ extremely fast disengagement
- ▶ low residual friction after disengagement

SIZING

INSTALLATION

BELLOWS COUPLINGS BK

MINIATURE COUPLINGS MK

ELASTOMER COUPLINGS EK | TX

SAFETY COUPLINGS SK | ES | SL

LINE SHAFTS ZA | EZ

DISC PACK COUPLINGS LP

ATEX CERTIFIED COUPLINGS

APPLICATIONS AND DESIGN FEATURES PRECISION COUPLINGS

BACKLASH FREE AND SMOOTH RUNNING LINE SHAFTS



P. 113

SIZES FROM 10 – 25,000 Nm

AREAS OF APPLICATION

for spanning large distances between shaft ends in:

- ▶ Material handling systems
- ▶ Printing machinery
- ▶ Labeling machinery
- ▶ Textile machinery
- ▶ Packaging machinery
- ▶ Converting equipment
- ▶ Lift systems
- ▶ Theatre automation
- ▶ Gantry systems
- ▶ Screw jack systems

FEATURES

- ▶ installation and removal without disturbing adjacent equipment
- ▶ self-supporting up to 6 meters
- ▶ no intermediate support bearing required

HIGH STRENGTH DISC PACK COUPLINGS



P. 125

SIZES FROM 350 – 20,000 Nm

AREAS OF APPLICATION

- ▶ API 610 pump packages
- ▶ Paper machinery
- ▶ Steel mill equipment
- ▶ Test stands
- ▶ Generators
- ▶ Bulk material handling systems
- ▶ Centrifuges
- ▶ Cooling tower drives
- ▶ Compressors
- ▶ Printing machinery

FEATURES

- ▶ maintenance free for infinite life
- ▶ frictional clamping of disc packs
- ▶ high speeds with extended DBSE
- ▶ zero backlash
- ▶ high torsional stiffness
- ▶ robust compact design
- ▶ precise transmission of angular motion and torque
- ▶ high operational dependability
- ▶ low restoring forces from misalignment
- ▶ compensation for lateral, axial and angular shaft misalignment

FOR USE IN HAZARDOUS ENVIRONMENTS – ATEX

ATEX

P. 133

AREAS OF APPLICATION

for safer operation in industries with explosive atmospheres, such as:

- ▶ Oil & gas extraction
- ▶ Petrochemical processing
- ▶ Munitions manufacturing
- ▶ Bulk and powder processing
- ▶ Paint systems

FEATURES

For hazard zones 1/21 and 2/22 these couplings are authorized under directive 94/9/EG.

- ▶ Bellows couplings
- ▶ Elastomer couplings
- ▶ Safety couplings
- ▶ Line shafts
- ▶ Disc pack couplings

SIZING

INSTALLATION

BELLOWS
COUPLINGS **BK**

MINIATURE
COUPLINGS **MK**

ELASTOMER
COUPLINGS **EK | TX**

SAFETY COUPLINGS
SK | ES | SL

LINE SHAFTS
ZA | EZ

DISC PACK
COUPLINGS **LP**

ATEX CERTIFIED
COUPLINGS

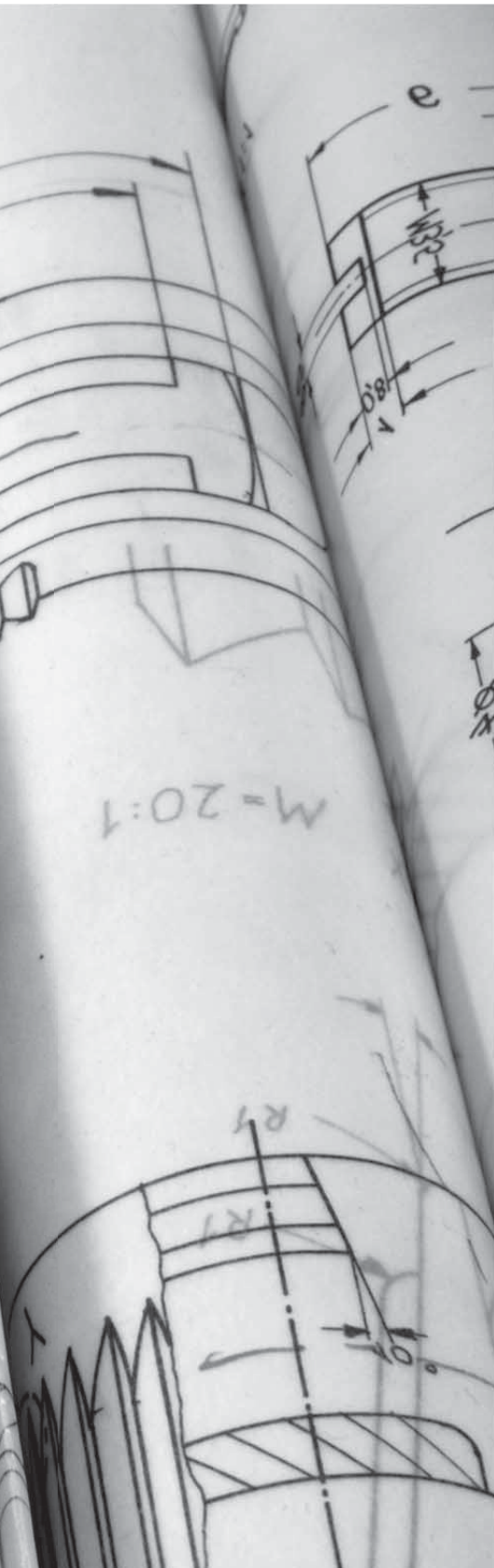
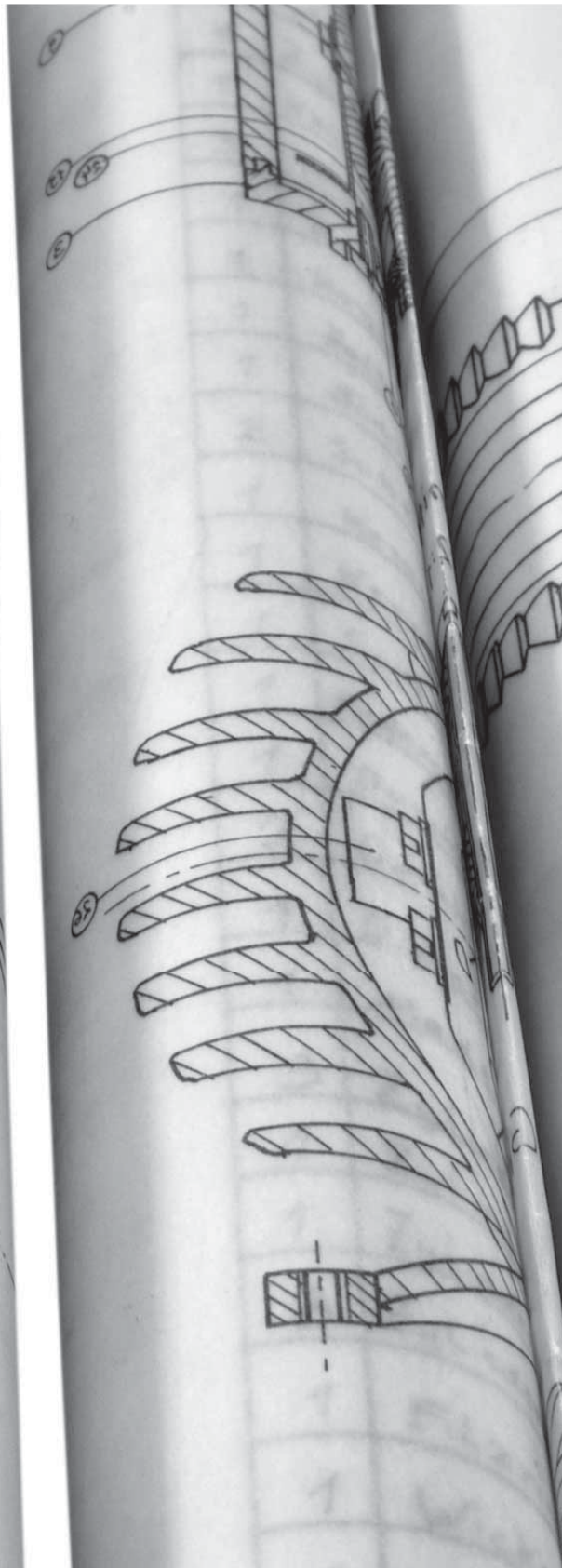
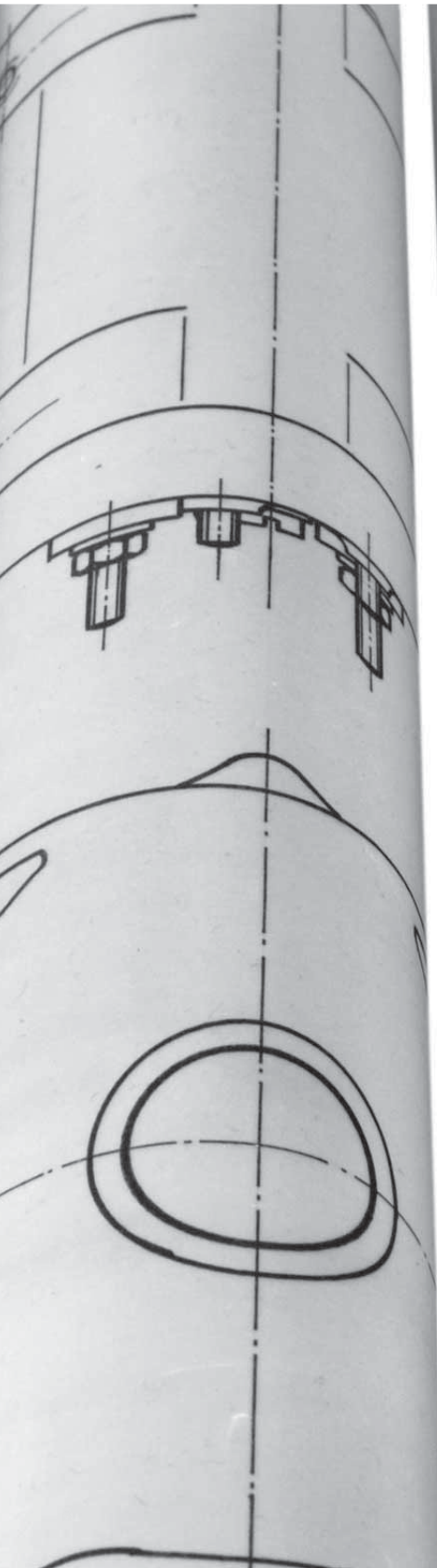

SIZING AND SELECTION

According to
DIN 740 part 2

SIZING AND SELECTION

BELLOWS COUPLINGS

BK

MK

SYMBOLS

- T_{KN} = Rated torque of the coupling (Nm)
 T_{AS} = Peak torque of the drive system
e.g. max. acceleration torque of drive (Nm)
or max. braking torque of load (Nm)
 J_L = Total load inertia
(e.g. spindle + slide + workpiece + 1/2 of coupling) (kgm²)
 J_A = Total driving inertia
(motor [including gear ratio] + 1/2 of coupling) (kgm²)
 C_T = Torsional stiffness of the coupling (Nm/rad)
 f_e = Natural frequency of the two mass system (Hz)
 f_{er} = Excitation frequency of the drive (Hz)
 φ = Torsional deflection (degree)

Shock or Load Factor S_A		
uniform load	non-uniform load	highly dynamic load
1	2	3-4
Common factor for servo drives in machine tools: $S_A = 2-3$		

ACCORDING TO TORQUE

Couplings are normally sized for the highest torque to be regularly transmitted. The peak torque of the application should not exceed the rated torque of the coupling. The following calculation provides an approximation of the minimum required coupling size, and allows for the maximum rated speed and misalignment to exist in the application:

$$T_{KN} \cong 1.5 \cdot T_{AS} \text{ (Nm)}$$

ACCORDING TO ACCELERATION TORQUE

A more detailed calculation takes acceleration and the driving and driven moments of inertia into account. A strong inertia ratio diminishes the effect of the load factor in the sizing calculation.

$$T_{KN} \cong T_{AS} \cdot S_A \cdot \frac{J_L}{J_A + J_L} \text{ (Nm)}$$

ACCORDING TO RESONANT FREQUENCY

The torsional natural frequency of the coupling must be significantly higher or lower than that of the equipment. For the mechanical substitution model the two mass system applies.

$$f_e = \frac{1}{2 \cdot \pi} \sqrt{C_T \cdot \frac{J_A + J_L}{J_A \cdot J_L}} \text{ (Hz)}$$

In practice the following applies: $f_e \geq 2 \cdot f_{er}$

Two Mass System

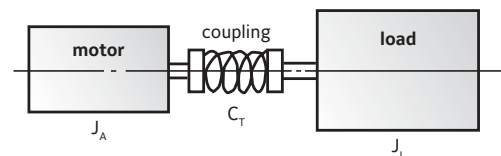

ACCORDING TO TORSIONAL DEFLECTION

To calculate transmission error as a result of torsional stress:

$$\varphi = \frac{180}{\pi} \cdot \frac{T_{AS}}{C_T} \text{ (degree)}$$

SIZING AND SELECTION

ELASTOMER COUPLINGS

EK

TX

ES

SYMBOLS

T_{KN}	= Rated torque of the coupling (Nm)
T_{Kmax}	= Maximum torque rating of the coupling (Nm)
T_S	= Peak torque applied to the coupling (Nm)
T_{AS}	= Peak torque of the drive system (Nm)
T_{AN}	= Nominal torque of the drive system (Nm)
T_{LN}	= Nominal torque of the load (Nm)
P	= Drive power (kW)
n	= Rotational speed (min. ⁻¹)
J_A	= Total driving inertia (motor [including gear ratio] + 1/2 of coupling) (kgm ²)
J_L	= Total load inertia (e.g. spindle + slide + workpiece + 1/2 of coupling) (kgm ²)
J_1	= Moment of inertia of driving coupling half (kgm ²)
J_2	= Moment of inertia of driven coupling half (kgm ²)
m	= ratio of the moment of inertia of the drive to the load
v	= Temperature at the coupling (observed radiant heat)
S_v	= Temperature factor
S_A	= Load factor
S_z	= Start factor (factor for the number of starts per hour)
Z_h	= Number of starts per hour (1/h)

Temperature factor S_v	A	B	C	E
Temperature (v)	Sh 98 A	Sh 64 D	Sh 80 A	Sh 64 D
> -30°C to -10°C	1.5	1.3	1.4	1.2
> -10°C to +30°C	1.0	1.0	1.0	1.0
> +30°C to +40°C	1.2	1.1	1.3	1.0
> +40°C to +60°C	1.4	1.3	1.5	1.2
> +60°C to +80°C	1.7	1.5	1.8	1.3
> +80°C to +100°C	2.0	1.8	2.1	1.6
> +100°C to +120°C	-	2.4	-	2.0
> +120°C to +150°C	-	-	-	2.8

Start factor S_z			
Z_h	up to 120	120 to 240	over 240
S_z	1.0	1.3	contact us

Shock or Load Factor S_A		
uniform load	non-uniform load	highly dynamic load
1	1.8	2.5

COUPLING SELECTION FOR OPERATION WITHOUT SHOCK OR REVERSAL

The rated torque of coupling (T_{KN}) must be greater than the rated torque of the load (T_{LN}), taking into account the temperature at the coupling (Temperature factor S_v). Should T_{LN} be unknown, T_{AN} can be used as a substitute in the formula.

Calculation

$$T_{KN} > T_{AN} \cdot S_v$$

Supplemental Calculation

$$T_{AN} = \frac{9,550 \cdot P}{n}$$

Sample calculation: (without shock loads)

Coupling conditions

$$v = 70^\circ \text{C}$$

$$S_v = 1.7 \text{ (or } 70^\circ \text{ Elastomer Type A)}$$

Drive for centrifugal pump

$$T_{AN} = 85 \text{ Nm}$$

$$\text{Calculation: } T_{KN} > T_{AN} \times S_v$$

$$T_{KN} > 85 \text{ Nm} \cdot 1,7$$

$$T_{KN} > \underline{144.5 \text{ Nm}} \longrightarrow \text{Result: Coupling model EK2/150/A (} T_{KN} = 160 \text{ Nm) is selected.}$$

COUPLING SELECTION FOR OPERATION WITH SHOCK LOADS

Same basic conditions as above. In addition, the maximum torque rating of the coupling (T_{Kmax}) is dictated by peak torque (T_s) due to shock loads.

Calculation

$$T_{KN} > T_{AN} \cdot S_v$$

Supplemental Calculation

$$T_{AN} = \frac{9,550 \cdot P_{LN}}{n}$$

Calculation

$$T_{Kmax} > T_s \cdot S_z \cdot S_v$$

Supplemental Calculation

$$T_s = \frac{T_{AS} \cdot S_A}{m + 1}$$

$$m = \frac{J_A \cdot J_1}{J_L \cdot J_2}$$

SIZING AND SELECTION

SAFETY COUPLINGS

SK

SL

ES

SYMBOLS

T_{KN}	= Rated torque of the coupling (Nm)
T_{AN}	= Load torque (Nm)
T_{AS}	= Peak torque of the motor (Nm)
J_L	= Moment of inertia of the load (kgm ²)
J_A	= Moment of inertia of the drive (kgm ²)
P_{AN}	= Drive power (kW)
α	= Angular acceleration $\frac{1}{s^2}$
t	= Acceleration / deceleration time (s)
ω	= Angular velocity (1/s)
n	= Drive speed (min ⁻¹)
s	= Screw lead (mm)
F_V	= Feed force (N)
η	= Spindle efficiency
d_0	= pinion dia. (pulley) (mm)
C_T	= Torsional stiffness of the coupling (Nm/rad)
$J_{Masch.}$	= Total load inertia (e.g. spindle + slide + workpiece + 1/2 of coupling) (kgm ²)
$J_{Mot.}$	= Total driving inertia (motor [including gear ratio] + 1/2 of coupling) (kgm ²)
f_e	= Natural frequency of the two mass system (Hz)
φ	= Torsional deflection (degree)

Shock or Load Factor S_A

uniform load	non-uniform load	highly dynamic load
1	2	3

Common factor for servo drives in machine tools: $S_A = 2-3$

ACCORDING TO DISENGAGEMENT TORQUE

Torque limiters are generally selected according to the required disengagement torque, which must be greater than the torque required for regular operation. The disengagement of the torque limiter is most commonly determined in accordance with the drive data. For this purpose, the following calculation applies:

$$T_{KN} \geq 1.5 \cdot T_{AS} \text{ (Nm)}$$

or

$$T_{KN} \geq 9,550 \cdot \frac{P_{AN}}{n} \cdot 1.5 \text{ (Nm)}$$

ACCORDING TO ACCELERATION (START-UP WITH NO LOAD)

$$T_{KN} \cong \alpha \cdot J_L \cong \frac{J_L}{J_A + J_L} \cdot T_{AS} \cdot S_A \text{ (Nm)}$$

$$\alpha = \frac{\omega}{n} = \frac{\pi \cdot n}{t \cdot 30}$$

ACCORDING TO ACCELERATION WITH LOAD (START-UP UNDER LOAD)

$$T_{KN} \cong \alpha \cdot J_L + T_{AN} \cong \left[\frac{J_L}{J_A + J_L} \cdot (T_{AS} - T_{AN}) + T_{AN} \right] \cdot S_A \text{ (Nm)}$$

ACCORDING TO LINEAR FEED FORCE

Spindle Drive (ball screw / lead screw)

$$T_{AN} = \frac{s \cdot F_v}{2,000 \cdot \pi \cdot \eta} \text{ (Nm)}$$

Belt Drive / Chain Drive

$$T_{AN} = \frac{d_0 \cdot F_v}{2,000} \text{ (Nm)}$$

ACCORDING TO RESONANT FREQUENCY (SK2 / SK3 / SK5 WITH METAL BELLOWS - ES2 / ESL WITH ELASTOMER RING)

The torsional natural frequency of the coupling must be significantly higher or lower than that of the equipment. For the mechanical substitution model the two mass system applies:

$$f_e = \frac{1}{2 \cdot \pi} \sqrt{C_T \times \frac{J_{Masch} + J_{Mot}}{J_{Masch} \cdot J_{Mot}}} \text{ (Hz)}$$

ACCORDING TO TORSIONAL DEFLECTION (SK2 / SK3 / SK5 WITH METAL BELLOWS - ES2 / ESL WITH ELASTOMER RING)

To calculate transmission error as a result of torsional stress:

$$\varphi = \frac{180}{\pi} \cdot \frac{T_{AN}}{C_T} \text{ (degree)}$$

ACCORDING TO LOAD HOLDING FUNCTION SYSTEM

► Load Holding Version

The SK1, SKP, and SKN models in the load holding version can secure a minimum of 2x their torque setting after disengagement. The SK2, SK3, and SK5 models can secure

only up to the torque rating of the flexible bellows after disengagement.

SIZING AND SELECTION

LINE SHAFTS



SYMBOLS

- A = Total length (mm)
- AB = Distance between flextures (mm)
AB = (A - 2xN)
- Z = Tube length (mm)
Z = (A - 2xH)
- H = Length of coupling ends (mm)
- N = Length to flexure (mm)
- T_{AS} = Peak torque of the drive (Nm)
- φ = Torsional deflection (degree)
- C_T^B = Torsional stiffness of both flexible elements (Nm/rad)
- C_T^{ZWR} = Torsional stiffness per 1m of tubing (Nm/rad)
- C_T^{ZA} = Total torsional stiffness (Nm/rad)
- n_k = Critical speed (1/min.)
- C_{Tdyn}^E = Dynamic torsional stiffness of both elastomer inserts (Nm/rad)
- C_{Tdyn}^{EZ} = Total torsional stiffness (Nm/rad)

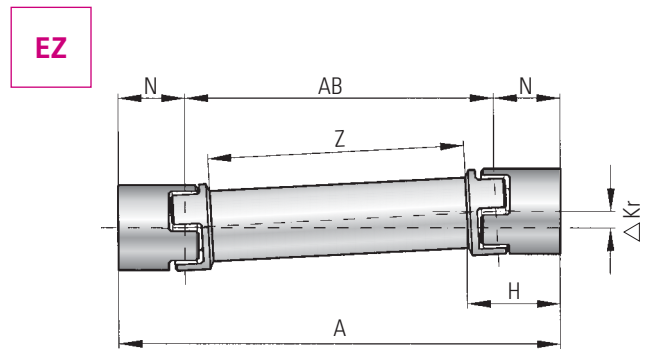
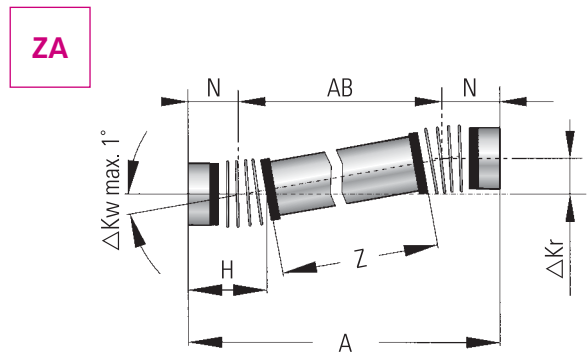

MODEL ZA

Size	Torsional stiffness of both bellows bodies C _T ^B (Nm/rad)	Torsional stiffness per 1m of standard tubing C _T ^{ZWR} (Nm/rad)	Torsional stiffness per 1m of CFK tubing C _T ^{ZWR} (Nm/rad)	Length of coupling ends ZA H (mm)	Length of coupling ends ZAE H (mm)	Length to flexure N (mm)	Maximum Axial misalignment Δ Ka (mm)
10	4,525	1,530	3,690	44.5	39.5	25	2
30	19,500	6,632	13,390	57.5	52	34	2
60	38,000	11,810	23,850	71	64	41	3
150	87,500	20,230	50,050	78	72	47	4
200	95,500	65,340	-	86	-	52	4
300	250,500	222,700	151,510	94	83	56	4
500	255,000	292,800	204,250	110	96	66	5
800	475,000	392,800	267,620	101	89	64	6
1500	1,400,000	728,800	-	92	-	56	4
4000	4,850,000	1,171,000	-	102	-	61	4

Table 1

MODEL EZ

Size	Torsional stiffness of both flexible elements		Torsional stiffness per 1m of tubing	Working length EZ	Length to flexure	Max. axial misalignment
	Elastomer insert A C_T^A (Nm/rad)	Elastomer insert B C_T^B (Nm/rad)	C_T^{ZWR} (Nm/rad)	H (mm)	N (mm)	Δ Ka (mm)
10	270	825	321	34	26	2
20	1,270	2,220	1,530	46	33	4
60	3,970	5,950	6,632	63	49	4
150	6,700	14,650	11,810	73	57	4
300	11,850	20,200	20,230	86	67	4
450	27,700	40,600	65,340	99	78	4
800	41,300	90,000	392,800	125	94	4
2500	87,500	108,000	1,000,000	142	108	5
4500	168,500	371,500	2,500,000	181	137	5
9500	590,000	670,000	5,000,000	229	171	6

Table 2

MAXIMUM TRANSMITTABLE TORQUE BY BORE DIAMETER (Nm)

Size	Ø 6	Ø 8	Ø 16	Ø 19	Ø 25	Ø 30	Ø 32	Ø 35	Ø 45	Ø 50	Ø 55	Ø 60	Ø 65	Ø 70	Ø 75	Ø 80	Ø 90	Ø 120	Ø 140	
10	6	12	32																	
20		30	40	50	65															
60			65	120	150	180	200													
150				180	240	270	300	330												
300				300	340	450	520	570	630											
450					630	720	770	900	1120	1180	1350									
800								1050	1125	1200	1300	1400	1450	1500	1550	1600				
2500								1900	2600	2900	3200	3500	3800	4000	4300	4600	5200			
4500									5300	5800	6300	7000	7600	8200	8800	9400	10600	14100		
9500										9200	10100	11100	11900	12800	13800	14800	16700	22000	25600	

TEMPERATURE FACTOR S

Temperature (φ)	A	B
	Sh 98 A	Sh 64 D
> -30° to -10°	1.5	1.7
> -10° to +30°	1.0	1.0
> +30° to +40°	1.2	1.1
> +40° to +60°	1.4	1.3
> +60° to +80°	1.7	1.5
> +80° to +100°	2.0	1.8
> +100° to +120°	-	2.4

ACCORDING TO TORSIONAL STIFFNESS

Condition: Line shaft ZA, size 150 $T_{AS} = 150$ Nm
 Wanted: Total torsional stiffness C_T^{ZA}

$$(C_T^{ZA}) = \frac{87,500 \text{ Nm/rad} \times (20,230 \text{ Nm/rad} / 1.344 \text{ m})}{87,500 \text{ Nm/rad} + (20,230 \text{ Nm/rad} / 1.344 \text{ m})} = 12,842.8 \text{ [Nm/rad]}$$

$$(C_T^{ZA}) = \frac{C_T^B \cdot (C_T^{ZWR}/Z)}{C_T^B + (C_T^{ZWR}/Z)} \text{ (Nm/rad)}$$

ACCORDING TO TORSIONAL DEFLECTION

Condition: Line shaft ZA, size 150 $T_{AS} = 150$ Nm
 Wanted: Torsional deflection at maximum acceleration torque T_{AS}

Measurement (A) of Line Shaft - 1.5m
 Length (Z) of Tubing = A-(2xH) = 1.344m

$$\varphi = \frac{180 \times 150 \text{ Nm}}{\pi \times 12,842.8 \text{ Nm/rad}} = 0.669^\circ$$

With a maximum torque of 150Nm the torsional deflection is 0.669°

$$\varphi = \frac{180 \cdot T_{AS}}{\pi \cdot C_T^{ZA}} \text{ (degree)}$$

SIZING AND SELECTION

LINE SHAFTS

ZA **EZ**

ACCORDING TO MAXIMUM MISALIGNMENT

	Lateral misalignment ΔKr	Angular misalignment ΔKw	Axial misalignment ΔKa
ZA			
EZ			
	$\Delta Kr_{max} = \tan \Delta \frac{Kw}{2} \cdot AB$ $AB = A - 2xN$	$\Delta Kw_{max} = 2^\circ$	See table 1+2 Pages 16+17

R+W CALCULATION PROGRAM

Using proprietary software, R+W will calculate the specific mechanical details of exactly the model you plan to use. Overall length, tube materials (e.g. steel, aluminum, CFK), and other factors are used to determine a number of performance values unique to your line shaft coupling.

- | | |
|-------------------------------|-----------------------------------|
| Critical speed | $n_k = 1/\text{min.}$ |
| Torsional stiffness of tubing | $C_T^{ZWR} = \text{Nm/rad}$ |
| Overall stiffness | $C_T^{ZA} = \text{Nm/rad}$ |
| Torsional deflection | $\varphi = \text{degree-min-sec}$ |
| Total Weight | $m = \text{kg}$ |
| Moment of inertia | $J = \text{kgm}^2$ |
| Maximum misalignment | $\Delta Kr = \text{mm}$ |

DISC PACK COUPLINGS

LP

SYMBOLS

- T_{KN} = Rated torque of the coupling (Nm)
- T_{AS} = Peak torque of the drive system
e.g. max. acceleration torque of drive (Nm)
or max. braking torque of load (Nm)
- J_L = Total load inertia (e.g. spindle + slide + workpiece +
1/2 of coupling) (kgm²)
- J_A = Total driving inertia (motor [including gear ratio] +
1/2 of coupling) (kgm²)
- C_T = Torsional stiffness of the coupling (Nm/rad)
- f_e = Natural frequency of the two mass system (Hz)
- f_{er} = Excitation frequency of the drive (Hz)
- φ = Torsional deflection (degree)

Shock or Load Factor S_A		
uniform load	non-uniform load	highly dynamic load
1	2	3-4
Common factor for servo drives in machine tools: $S_A = 2-3$		

ACCORDING TO TORQUE

Couplings are normally sized for the highest torque to be regularly transmitted. The peak torque of the application should not exceed the rated torque of the coupling. The following calculation provides an approximation of the minimum required coupling size, and allows for the maximum rated speed and misalignment to exist in the application.

$$T_{KN} \cong 1.5 \cdot T_{AS} \text{ (Nm)}$$

ACCORDING TO ACCELERATION TORQUE

A more detailed calculation takes acceleration and the driving and driven moments of inertia into account. A strong inertia ratio diminishes the effect of the load factor in the sizing calculation.

$$T_{KN} \cong T_{AS} \cdot S_A \cdot \frac{J_L}{J_A + J_L} \text{ (Nm)}$$



INSTALLATION AND HANDLING

SHAFT / AXIS MISALIGNMENT

Exact alignment of the shaft axes extends the service life of the coupling and adjacent components by minimizing reaction loads from misalignment.

FIT CLEARANCE

Overall shaft / hub clearance of 0.01 - 0.05 mm

INSTALLATION AND HANDLING PRECISION COUPLINGS



The installation and operating instructions are an integral part of the R+W coupling. Please read carefully and follow all instructions. Failure to comply with these procedures could result in poor performance and / or failure of the coupling. Installation should be performed by a qualified technician. This manual will be included with the delivery of the coupling.

INDIRECT DRIVES

SAFETY COUPLINGS / TORQUE LIMITERS

Drive components (e.g. timing belt sprockets) must be centered on the output flange prior to mounting. Please also refer to the maximum overhung load ratings and locations provided on page 89. If the overhung load is beyond the capacity of the coupling bearings, an additional bearing can be mounted on the shaft to support the overhung load.

SK1

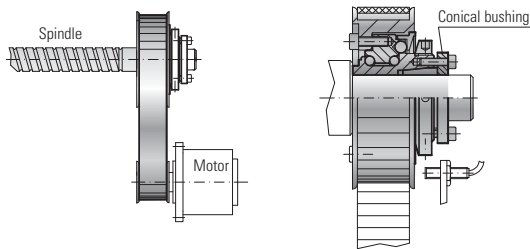

WITH CONICAL CLAMPING SYSTEM

SKP

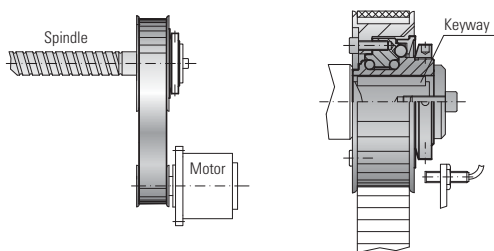

WITH KEYWAY ONLY

SKN

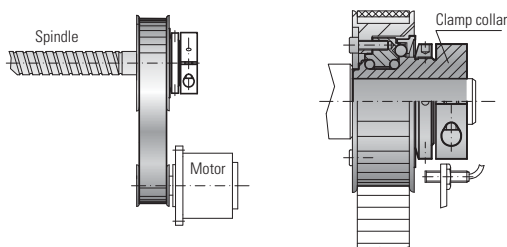

WITH CLAMP COLLAR

DIRECT DRIVES

METAL BELLOWS COUPLINGS

R+W bellows couplings are flexible shaft couplings. The flexible, torsionally rigid, stainless steel bellows provides backlash free torque transmission while compensating for lateral, axial, and angular misalignment, with very low restoring forces. A number of different hub designs are available to suit a variety of application requirements.

BK2

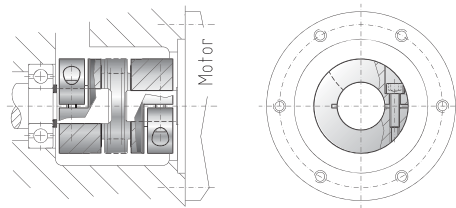

WITH CLAMPING HUB

BKH

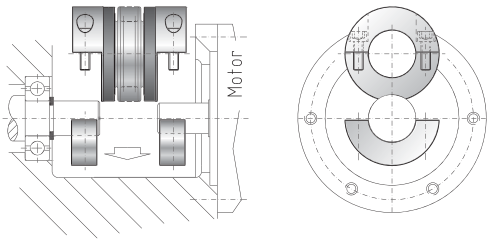

WITH FULLY SPLIT CLAMPING HUB

BK3

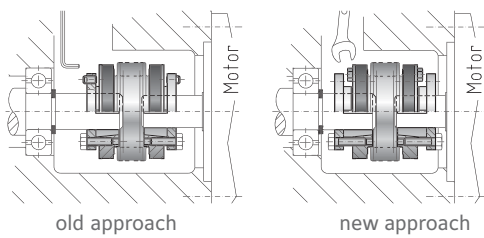

WITH CONICAL CLAMPING HUB

BK5

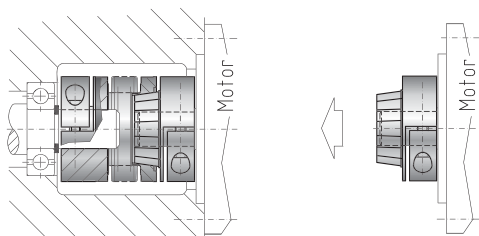

WITH CLAMPING HUB AND BLIND MATE CONNECTION

BK6

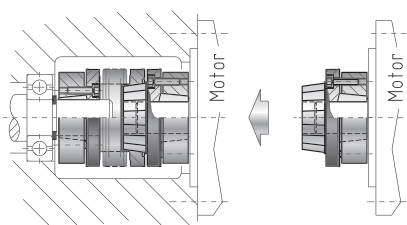

WITH CONICAL CLAMPING RING AND BLIND MATE CONNECTION

INSTALLATION AND HANDLING PRECISION COUPLINGS

DIRECT DRIVES

BK7

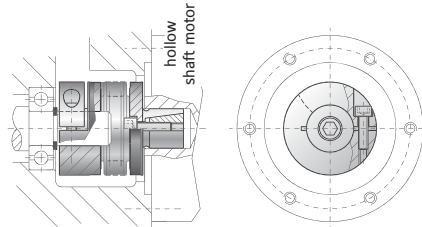

WITH EXPANDING SHAFT

BK8

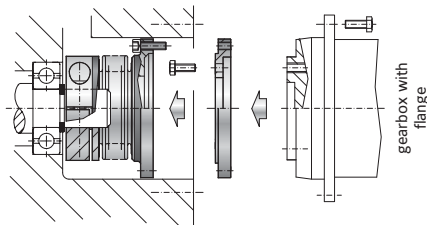

FOR ISO FLANGE MOUNTING

BK1

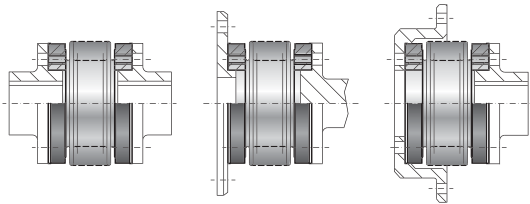

WITH SIMPLE MOUNTING FLANGE

MK1

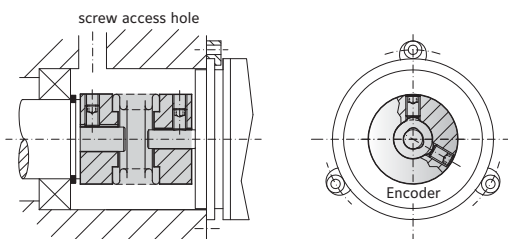

WITH RADIAL SET SCREWS

MK4

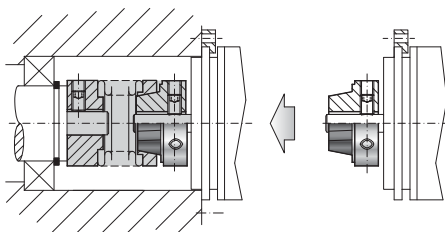

WITH RADIAL SET SCREWS
AND BLIND MATE CONNECTION

MK6

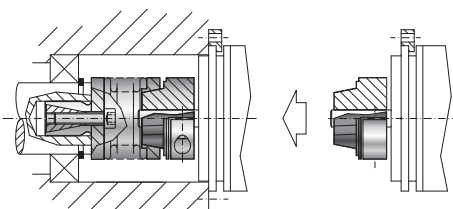

WITH EXPANDING SHAFT
AND BLIND MATE CONNECTION

DIRECT DRIVES

ELASTOMER COUPLINGS

The equalizing element of EK couplings is the elastomer insert. It transmits torque without backlash or vibration. The elastomer insert defines the characteristics of the entire drive system. The coupling is backlash free due to a pretensioning of the elastomer insert between the two coupling halves. SERVOMAX couplings compensate for lateral, angular, and axial misalignment.

EK2

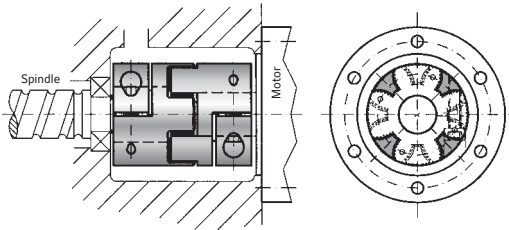

WITH CLAMPING HUB

EKH

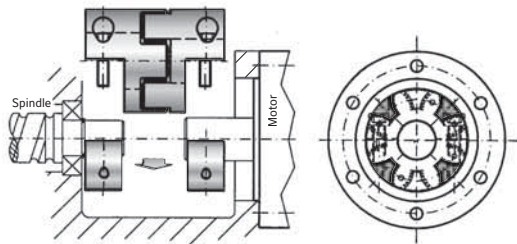

WITH FULLY SPLIT CLAMPING HUB

EK6

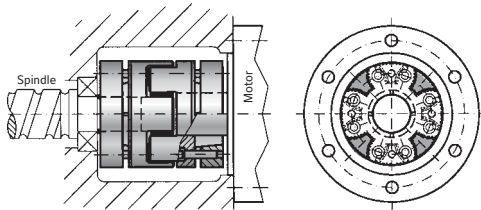

WITH CONICAL CLAMPING RING

EKZ

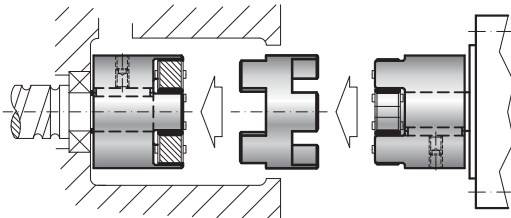

WITH DOUBLE FLEX AND SPACER

EK7

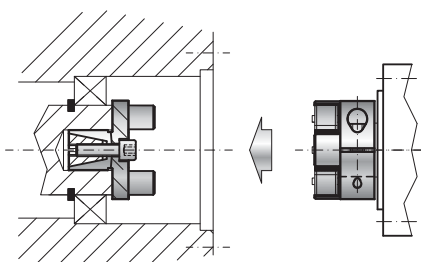

WITH EXPANDING SHAFT

INSTALLATION AND HANDLING PRECISION COUPLINGS

DIRECT DRIVES

LINE SHAFTS

R+W line shafts are flexible shaft couplings for spanning longer distances between shaft ends. The compensation elements (bellows or elastomer) compensate for lateral, axial, and angular shaft misalignment. Torque transmission is backlash free with high torsional stiffness (bellows) or vibration damping (elastomer). In the case of bellows couplings, the tube is carried over a special support system which transfers the weight back to the hubs. Below are the various hub / shaft connections available.

ZA

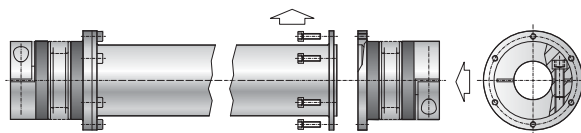

WITH CLAMPING HUB

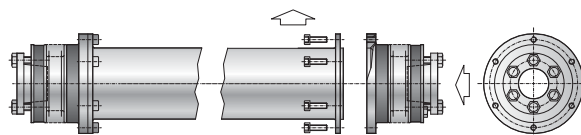

WITH CONICAL CLAMPING HUB

ZAE

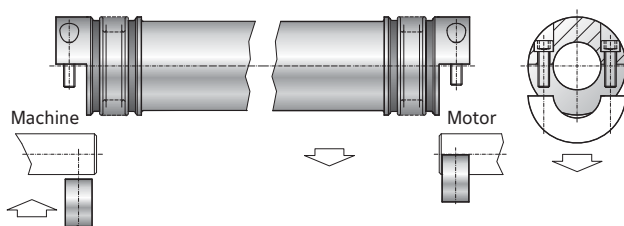

WITH FULLY SPLIT CLAMPING HUB

EZ2

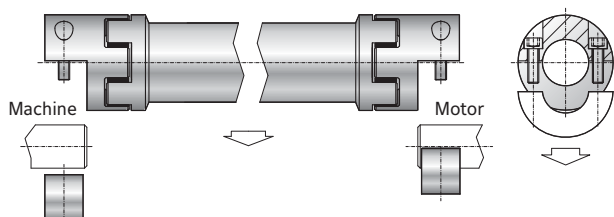

WITH FULLY SPLIT CLAMPING HUB

DIRECT DRIVES

VERTICAL INSTALLATION

ZA

ZAE

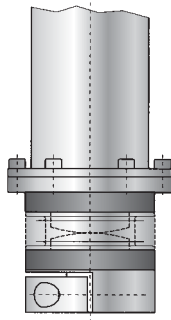

- ▶ In vertical installations a special support transfers the weight to the bottom hub.
- ▶ This support system is available for all sizes.
- ▶ Please note, "for vertical installation" when ordering.

Schematic of support system

DISC PACK COUPLINGS

R+W LP disc pack couplings are supplied as individual components. The disc packs absorb axial and angular misalignment, as well as lateral misalignment when two sets are used in series. Torque is transmitted with zero backlash across the frictional engagement of the assembly and not by the grade 12.9 screws themselves. Thus micro movements are avoided, vastly extending the service life of the coupling.

LP1

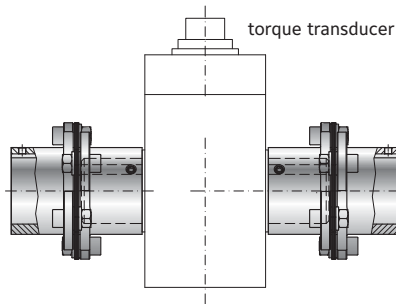

WITH KEYWAY MOUNTING

LP2

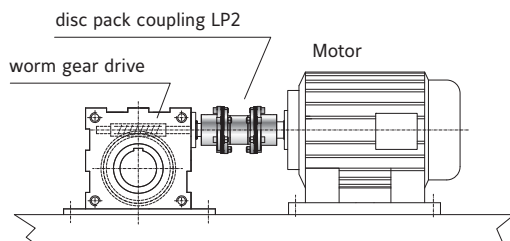

DOUBLE FLEX WITH KEYWAY MOUNTING

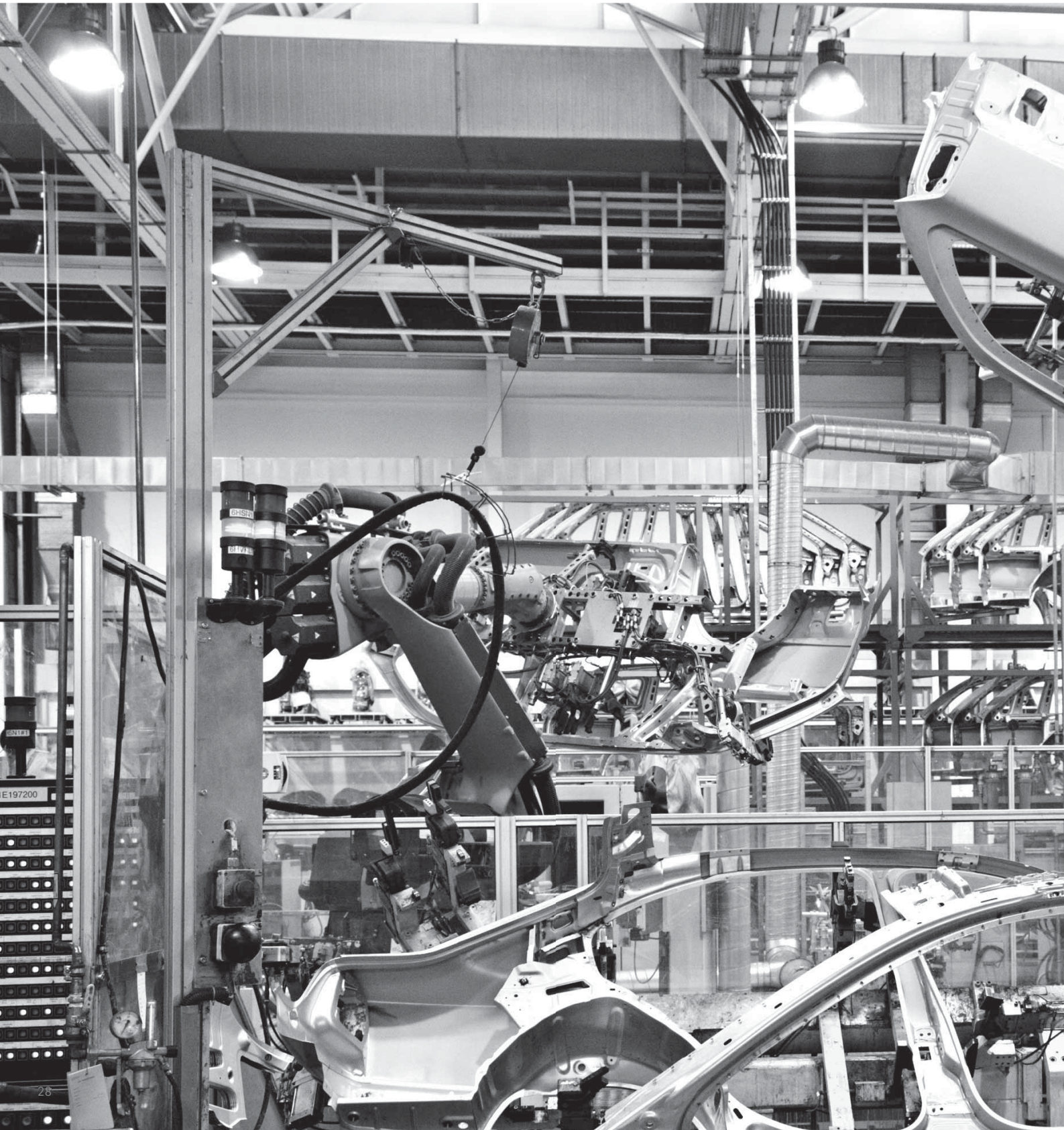

E197200



SIZES FROM 2 - 10,000 Nm

BACKLASH FREE, TORSIONALLY STIFF

METAL BELLOWS COUPLINGS

GENERAL INFORMATION ABOUT R+W BELLOWS COUPLINGS:



SERVICE LIFE

R+W bellows couplings are fatigue resistant and wear free for an infinite service life, as long as the technical limits are not exceeded.

FIT CLEARANCE

Overall shaft / hub clearance of 0.01 - 0.05 mm

ROTATIONAL SPEED

Standard up to 10,000 rpm.
Over 10,000 rpm in finely balanced version; up to grade ISO G=2.5 is available.

TEMPERATURE RANGE

-30 to +100° C

SPECIAL SOLUTIONS

Various materials, tolerances, dimensions and performance ratings available for custom applications on request.

ATEX (Optional)

For use in hazardous zones 1/21 and 2/22, the metal bellows has been authorized under directive 94/9/EG and is available with certification.

TORSIONALLY STIFF BELLOWS COUPLINGS SIZES FROM 2 - 10,000 Nm

MODEL

FEATURES

BK2



**with clamping hub
from 15 - 10,000 Nm**

- ▶ easy to mount
- ▶ available in multiple lengths
- ▶ low moment of inertia

Page 34

BKH



**with fully split clamping hub
from 15 - 4,000 Nm**

- ▶ radial mounting possible
- ▶ easy to install onto pre-aligned shafts
- ▶ low moment of inertia

Page 35

BKL



**economy class with clamping hub
from 2 - 500 Nm**

- ▶ economy design
- ▶ optional self-opening clamp system
- ▶ low moment of inertia

Page 36

BKS



**with clamping hub
from 15 - 500 Nm**

- ▶ all stainless steel construction
- ▶ temperatures up to 300°C
- ▶ easy to mount

Page 37

MODEL

FEATURES

BKC



**economy class with clamping hub
from 15 - 500 Nm**

Page 38

- ▶ low moment of inertia
- ▶ compact design
- ▶ optional self-opening clamp system

BKM



**with clamping hub
from 20 - 1,000 Nm**

Page 39

- ▶ high torque density
- ▶ ultra compact
- ▶ lowest moment of inertia of all clamping hub designs

BK3



**with conical clamping hub
from 15 - 10,000 Nm**

Page 40

- ▶ high clamping pressure
- ▶ modern design for removal system
- ▶ highly reliable

BK4



**for tapered shafts
from 15 - 150 Nm**

Page 41

- ▶ standard 1:10 taper with feather keyway
- ▶ special designs on request

TORSIONALLY STIFF BELLOWS COUPLINGS SIZES FROM 2 - 10,000 Nm

MODEL

FEATURES

BK5



**with clamping hub and
blind mate connection
from 15 - 1,500 Nm**

- ▶ backlash free with two piece design
- ▶ easy installation and removal
- ▶ available as separate components

Page 42

BK6



**with conical clamping ring and
blind mate connection
from 15 - 1,500 Nm**

- ▶ eliminates need for screw access holes
- ▶ self centering hubs for highly concentric mounting
- ▶ easy installation and removal

Page 43

BK7



**with expanding shaft
from 15 - 300 Nm**

- ▶ for hollow shaft mounting
- ▶ save space and cost
- ▶ solution for mismatched shaft/bore diameters

Page 44

BK8



**with ISO flange mounting
from 50 - 2,600 Nm**

- ▶ for flange output gearboxes
- ▶ allows for continuous hollow through axis with some right angle gearbox designs
- ▶ compact layout

Page 45

MODEL

FEATURES

BK1



**with simple flange mounting
from 15 - 10,000 Nm**

- ▶ for adapting the metal bellows to custom drive components
- ▶ custom flange patterns available

Page 46

BK2

WITH CLAMPING HUB

15 - 10,000 Nm

ABOUT



FEATURES

- ▶ easy to mount
- ▶ Optional: bolt tensioning system in size 800 and up
- ▶ light weight and low moment of inertia

DESIGN

Two clamping hubs concentrically mounted to flexible bellows. Brief overloads of up to 1.5x the rated torque are acceptable.

MATERIAL

- ▶ **Bellows:** high grade stainless steel
- ▶ **Hubs:** see table

NEW

Advantage: reduce screw tightening torques by up to 90% by using multiple smaller screws to create the same tension.

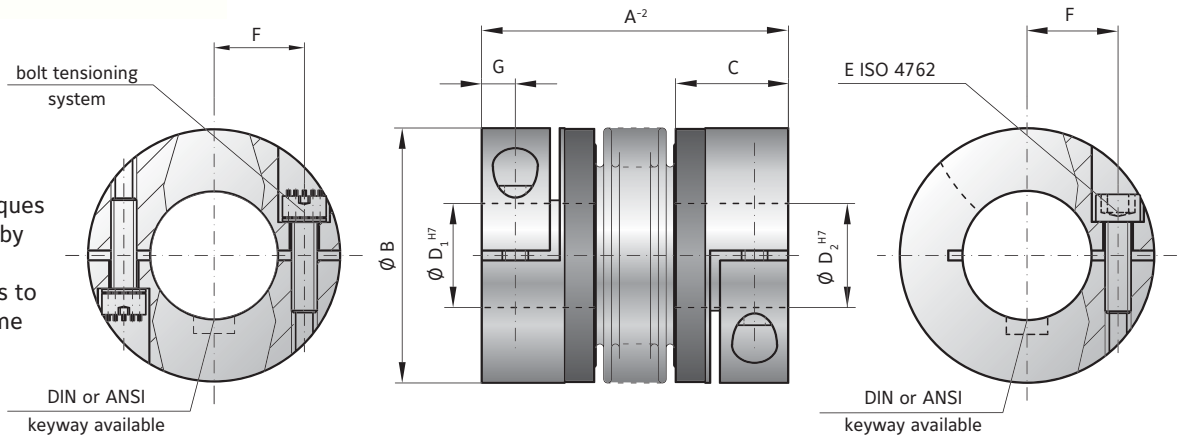

MODEL BK2

SIZE		15	30	60	80	150	200	300	500	800	1500	4000	6000	10000				
Rated torque (Nm)	T_{KN}	15	30	60	80	150	200	300	500	800	1500	4000	6000	10000				
Overall length (mm)	A^{-2}	59 66 99	69 77 113	83 93 130	94 106 143	95 107 144	105 117 163	111 125 200	133 146 169	140 179	166 230	225	252	288				
Outside diameter (mm)	B	49	55	66	81	81	90	110	124	134	157	200	253	303				
Fit length (mm)	C	22	27	31	36	36	41	43	51	45	55	85	107	129				
Inside diameter possible from \emptyset to \emptyset H7 (mm)	D_1/D_2	8-28	10-30	12-35	14-42	19-42	22-45	24-60	35-60	40-75	50-80	50-90	60-140	70-180				
Fastening screw ISO 4762	E	M5	M6	M8	M10	M10	M12	M12	M16	2x M16*	2x M20*	2x M24*	2x M24*	2x M30*				
Tightening torque of the fastening screw (Nm)		8	15	40	50	70	120	130	200	250	470	1200	1200	2400				
Distance between centerlines (mm)	F	17	19	23	27	27	31	39	41	2x48	2x55	2x65	2x90	2x117				
Distance (mm)	G	6.5	7.5	9.5	11	11	12.5	13	16.5	18	22.5	28	35	42				
Moment of inertia (10^{-3} kgm ²)	J_{res}	0.06 0.07 0.08	0.12 0.13 0.14	0.32 0.35 0.4	0.8 0.85 0.9	1.9 2 2.1	3.2 3.4 3.6	7.6 7.9 8.3	14.3 14.6 14.8	16.2 17	43 45	165	495	1214				
Hub material		Al optional steel	Al optional steel	Al optional steel	Al optional steel	steel optional AL	steel optional AL	steel optional AL	steel optional AL	steel	steel	steel	steel	steel				
Approximate weight (kg)		0.16	0.26	0.48	0.8	1.85	2.65	4	6.3	5.7	11.5	28.8	49.4	80.9				
Torsional stiffness (10^3 Nm/rad)	C_T	20 15 14	39 28 27	76 55 54	129 85 84	175 110 97	191 140 135	450 350 340	510 500 400	780 711	1304 1180	3400	5700	10950				
Axial \pm (mm)		1 2 3	1 2 3	1.5 2 3	2 3 4	2 3 4	2 3 4	2.5 3.5 4.5	2.5 3.5 4.5	3.5 4.5	3.5 4.5	3.5	3	3				
Lateral \pm (mm)	Max. values	0.15 0.2	1 0.2 0.25	1 0.2 0.25	1 0.2 0.25	1 0.2 0.25	1 0.25 0.3	1 0.25 0.3	1 0.3 0.35	1 0.35	1 0.35	1	0.4	0.4				
Angular \pm (degree)		1 1.5 2	1 1.5 2	1 1.5 2	1 1.5 2	1 1.5 2	1 1.5 2	1 1.5 2	1 1.5 2	1 1.5 2	1 1.5 2	1.5	1.5	1.5				
Axial spring stiffness (N/mm)	C_a	25 15 84	50 30 118	72 48 165	48 32 144	82 52 130	90 60 280	105 71 605	70 48 85	100 285	320 440	565	1030	985				
Lateral spring stiffness (N/mm)	C_r	475 137	140 900	270 224	1200 420	337 920	290 401	1550 435	500 2040	610 750	3750 1050	1200 2500	840 614	2000 1490	3600 1700	6070	19200	21800

* 180° opposed in each clamping hub.

WITH FULLY SPLIT CLAMPING HUB

15 - 4,000 Nm



ABOUT

FEATURES

- ▶ radial mounting possible
- ▶ easy installation onto pre-aligned shafts
- ▶ low moment of inertia

DESIGN

Two split clamping hubs with two screws in each. Brief overloads of up to 1.5x the rated torque are acceptable.

MATERIAL

- ▶ **Bellows:** high grade stainless steel
- ▶ **Hubs:** see table

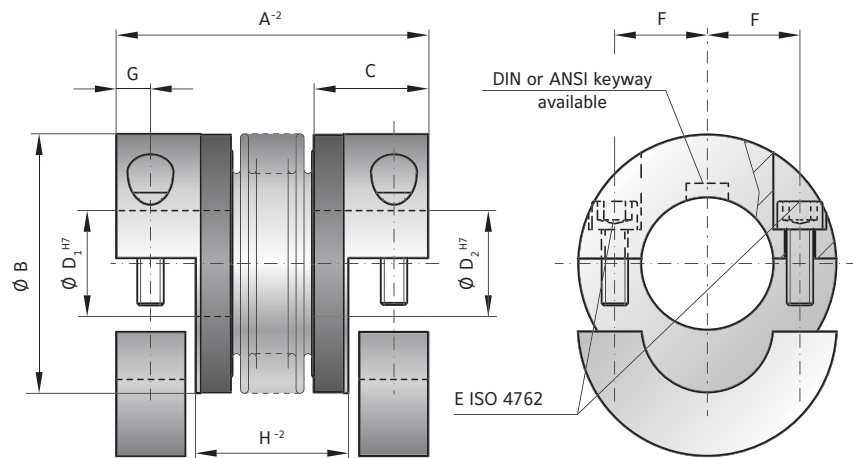

BELLOWS
COUPLINGS BK

MODEL BKH

SIZE		15	30	60	80	150	200	300	500	800	1500	4000
Rated torque (Nm)	T_{KN}	15	30	60	80	150	200	300	500	800	1500	4000
Overall length (mm)	A^{-2}	59 66	69 77	83 93	94 106	95 107	105 117	111 125	133 146	140 166	225	
Outside diameter (mm)	B	49	55	66	81	81	90	110	124	134	157	200
Fit length (mm)	C	22	27	31	36	36	41	43	51	45	55	85
Inside diameter possible from \emptyset to \emptyset H7 (mm)	D_1/D_2	8-28	10-30	12-35	14-42	19-42	22-45	24-60	35-60	40-75	50-80	50-90
Fastening screw ISO 4762	E	M5	M6	M8	M10	M10	M12	M12	M16	M16	M20	M24
Tightening torque of the fastening screw (Nm)		8	15	40	50	70	120	130	200	250	470	1200
Distance between centerlines (mm)	F	17	19	23	27	27	31	39	41	48	55	65
Distance (mm)	G	6.5	7.5	9.5	11	11	12.5	13	16.5	18	22.5	28
Distance (mm)	H^{-2}	29 36	35 43	41 51	47 59	48 60	51 63	55 69	62 75	65.5 71	107	
Moment of inertia (10^{-3} kgm ²)	J_{ges}	0.07 0.08	0.14 0.15	0.23 0.26	0.65 0.67	2.5 3.2	4.5 5.4	8.5 10.5	17.3 19.6	24.3	49.2	165
Hub material		Al optional steel	Al optional steel	Al optional steel	Al optional steel	steel optional AL	steel optional AL	steel optional AL	steel optional AL	steel	steel	steel
Approximate weight (kg)		0.15	0.3	0.4	0.8	1.7	2.5	4	7.5	7	12	28
Torsional stiffness (10^3 Nm/rad)	C_T	20 15	39 28	76 55	129 85	175 110	191 140	450 350	510 500	780	1304	3400
Axial \pm (mm)	Max. values	1 2	1 2	1.5 2	2 2	3 2	3 2	2 3	2.5 3.5	2.5 3.5	3.5 3.5	3.5 3.5
Lateral \pm (mm)		0.15 0.2	0.2 0.25	0.2 0.25	0.2 0.25	0.2 0.25	0.25 0.25	0.25 0.25	0.3 0.25	0.3 0.35	0.35 0.35	0.35 0.4
Angular \pm (degree)		1 1.5	1 1.5	1 1.5	1 1.5	1 1.5	1 1.5	1 1.5	1 1.5	1 1.5	1.5 1.5	1.5 1.5
Axial spring stiffness (N/mm)	C_a	25 15	50 30	72 48	48 32	82 52	90 60	105 71	70 48	100	320	565
Lateral spring stiffness (N/mm)	C_r	475 137	900 270	1200 420	920 290	1550 435	2040 610	3750 1050	2500 840	2000	3600	6070

ORDERING EXAMPLE	BK2 / BKH	80	94	20	22.23	XX
Model	●					
Size		●				
Overall length mm			●			Special designation only (e.g. anodized hubs).
Bore D1 H7				●		
Bore D2 H7					●	
For custom features place an XX at the end of the part number and describe the special requirements (e.g. BKH/80/94/20/22.23/XX; XX=finely balanced for 25,000 rpm)						

BKL

WITH CLAMPING HUB

2 - 500 Nm



ABOUT

FEATURES

- ▶ easy to mount
- ▶ light weight and low moment of inertia
- ▶ economical design

MATERIAL

- ▶ **Bellows:** high grade stainless steel
- ▶ **Hubs:** see table

DESIGN

Two clamping hubs concentrically mounted to flexible bellows. Brief overloads of up to 1.5x the rated torque are acceptable.

Optional: self-opening clamp system to open the bore during installation and removal by backing out the clamping screw.

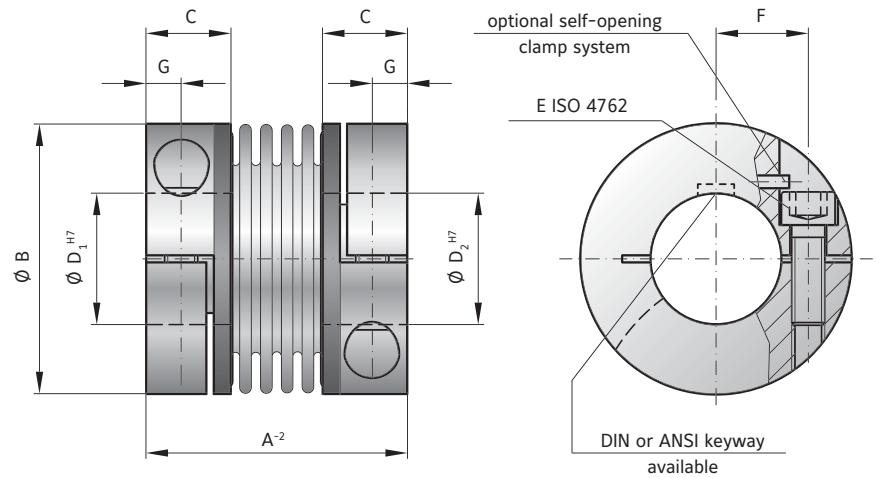

MODEL BKL

SIZE			2	4.5	10	15	30	60	80	150	300	500
Rated torque (Nm)	T_{KN}		2	4.5	10	15	30	60	80	150	300	500
Overall length (mm)	A^{-2}		30	40	44	58	68	79	92	92	109	114
Outside diameter (mm)	B		25	32	40	49	56	66	82	82	110	123
Fit length (mm)	C		10.5	13	13	21.5	26	28	32.5	32.5	41	42.5
Inside diameter possible from \emptyset to \emptyset H7 (mm)	$D_{1/2}$		4-12.7	6-16	6-24	8-28	10-32	14-35	16-42	19-42	24-60	35-62
Fastening screw ISO 4762			M3	M4	M4	M5	M6	M8	M10	M10	M12	M16
Tightening torque of the fastening screw (Nm)	E		2.3	4	4.5	8	15	40	70	85	120	200
Distance between centerlines (mm)	F		8	11	14	17	20	23	27	27	39	41
Distance (mm)	G		4	5	5	6.5	7.5	9.5	11	11	13	17
Moment of inertia (10^{-3} kgm ²)	J_{ges}		0.002	0.007	0.016	0.065	0.12	0.3	0.75	1.8 0.8	7.5 3.1	11.7 4.9
Hub material			AL optional steel	AL optional steel	AL optional steel	AL optional steel	AL optional steel	AL optional steel	AL optional steel	steel optional AL	steel optional AL	steel optional AL
Approximate weight (kg)			0.02	0.05	0.06	0.16	0.25	0.4	0.7	1.7 0.75	3.8 1.6	4.9 2.1
Torsional stiffness (10^3 Nm/rad)	C_T		1.5	7	9	23	31	72	80	141	157	290
Axial \pm (mm)		Max. values	0.5	1	1	1	1	1.5	2	2	2	2.5
Lateral \pm (mm)			0.2	0.2	0.2	0.2	0.2	0.2	0.2	0.2	0.2	0.2
Angular \pm (degree)			1	1	1	1	1	1	1	1	1	1
Axial spring stiffness (N/mm)	C_a		8	35	30	30	50	67	44	77	112	72
Lateral spring stiffness (N/mm)	C_r		50	350	320	315	366	679	590	960	2940	1450

ORDERING EXAMPLE	BKL	80	26	22.23	XX
Model	●				
Size		●			
Bore D1 H7			●		
Bore D2 H7				●	
For custom features place an XX at the end of the part number and describe the special requirements (e.g. BKL/80/26/22.23/XX; XX=finely balanced for 25,000 rpm)					



WITH STAINLESS STEEL CLAMPING HUB

15 - 500 Nm

ABOUT

FEATURES

- ▶ for high temperatures and aggressive media
- ▶ compact design
- ▶ easy to mount

MATERIAL

- ▶ **Bellows:** high grade stainless steel
- ▶ **Hubs:** high grade stainless steel

- ▶ **Screws:** Grade 12.9 Geomet coated (alternate materials on request)

DESIGN

Two clamping hubs concentrically mounted to flexible bellows. Brief overloads of up to 1.5x the rated torque are acceptable. From -40° to +300°C operating temperature.



Optional: self-opening clamp system to open the bore during installation and removal by backing out the clamping screw.

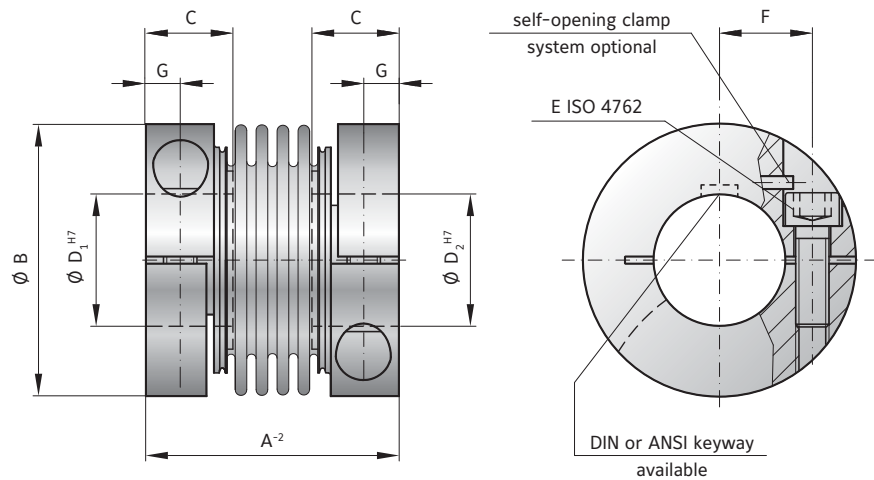

BELLOWS
COUPLINGS BK

MODEL BKS

SIZE			15	30	60	150	300	500
Rated torque (Nm)	T_{KN}		15	30	60	150	300	500
Overall length (mm)	A^{-2}		45	52	66	76	89	95
Outside diameter (mm)	B		49	56	66	82	110	123
Fit length (mm)	C		17	20	24	30	34	35
Inside diameter* possible from \emptyset to \emptyset H7 (mm)	D_1/D_2		12-28	14-32	16-35	19-42	24-60	32-75
Fastening screw ISO 4762			M5	M6	M8	M10	M12	M12
Tightening torque of the fastening screw (Nm)	E		8	15	40	75	120	125
Distance between centerlines (mm)	F		17.5	20	23	27	39	45
Distance (mm)	G		6	7.5	9.5	11	13	13
Moment of inertia (10^{-3} kgm ²)	$J_{ges.}$		0.1	0.2	0.53	1.5	5.5	8.1
Approximate weight (kg)			0.27	0.42	0.78	1.5	2.9	3.5
Torsional stiffness (10^3 Nm/rad)	C_T		23	31	72	141	157	290
Axial \pm (mm)		Max. values	1	1	1.5	2	2	2.5
Lateral \pm (mm)			0.2	0.2	0.2	0.2	0.2	0.2
Angular \pm (degree)			1	1	1	1	1	1
Axial spring stiffness (N/mm)	C_a		30	50	67	77	112	72
Lateral spring stiffness (N/mm)	C_r		315	366	679	960	2940	2200
Speed max. with G = 2.5 balancing (min ⁻¹)			60,000	50,500	50,000	40,500	40,000	30,000

* Smaller bore diameter available at reduced torque capacity

ORDERING EXAMPLE	BKS	15	20	19.05	XX
Model	●				
Size		●			
Bore D1 H7			●		
Bore D2 H7				●	
For custom features place an XX at the end of the part number and describe the special requirements (e.g. BKS/15/20/19.05/XX; XX=finely balanced for 25,000 rpm)					

Special designation only (e.g. special bore tolerance).



ABOUT

FEATURES

- ▶ for space restricted installations
- ▶ light weight and low moment of inertia
- ▶ easy to mount

MATERIAL

- ▶ **Bellows:** high grade stainless steel
- ▶ **Hubs:** see table

DESIGN

Two clamping hubs concentrically mounted to flexible bellows. Brief overloads of up to 1.5x the rated torque are acceptable.

Optional: self-opening clamp system to open the bore during installation and removal by backing out the clamping screw.

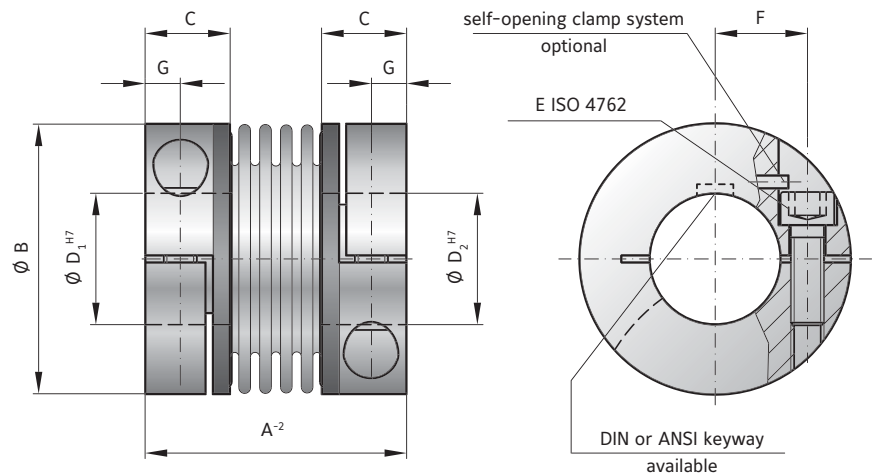

MODEL BKC

SIZE			15	30	60	150	300	500
Rated torque (Nm)	T_{KN}		15	30	60	150	300	500
Overall length (mm)	A^{-2}		48	58	67	78	94	100
Outside diameter (mm)	B		49	56	66	82	110	123
Fit length (mm)	C		16.5	21	23	27.5	34	34
Inside diameter possible from \emptyset to \emptyset H7 (mm)	D_1/D_2		8-28	12-32	14-35	19-42	24-60	32-75
Fastening screw ISO 4762			M5	M6	M8	M10	M12	M12
Tightening torque of the fastening screw (Nm)	E		8	15	40	75	120	125
Distance between centerlines (mm)	F		17.5	20	23	27	39	45
Distance (mm)	G		6.5	7.5	9.5	11	13	13
Moment of inertia (10^{-3} kgm ²)	$J_{res.}$		0.05	0.1	0.26	0.65	6.3	9
Hub material			AL	AL	AL	AL	steel	steel
Approximate weight (kg)			0.13	0.21	0.37	0.72	3.26	3.52
Torsional stiffness (10^3 Nm/rad)	C_T		23	31	72	141	157	290
Axial \pm (mm)	Max. values		1	1	1.5	2	2	2.5
Lateral \pm (mm)			0.2	0.2	0.2	0.2	0.2	0.2
Angular \pm (degree)			1	1	1	1	1	1
Axial spring stiffness (N/mm)	C_a		30	50	67	77	112	72
Lateral spring stiffness (N/mm)	C_r		315	366	679	960	2940	2200
Speed max. with G = 2.5 balancing (min^{-1})			80,000	70,000	60,000	50,000	40,000	30,000

ORDERING EXAMPLE	BKC	60	26	22.23	XX
Model	●				Special designation only (e.g. special bore tolerance).
Size		●			
Bore D1 H7			●		
Bore D2 H7				●	
For custom features place an XX at the end of the part number and describe the special requirements (e.g. BKC/60/26/22.23/XX; XX=finely balanced for 25,000 rpm)					

ULTRA COMPACT AND STIFF WITH CLAMPING HUB 20 - 1,000 Nm

ABOUT

FEATURES

- ▶ extremely compact
- ▶ high torque density
- ▶ low mass and moment of inertia

MATERIAL

- ▶ **Bellows:** high grade stainless steel
- ▶ **Hubs:** see table

DESIGN

Two clamping hubs concentrically mounted to flexible bellows. Brief overloads of up to 1.5x the rated torque are acceptable.



Key application:
For mounting on a torque transducer.

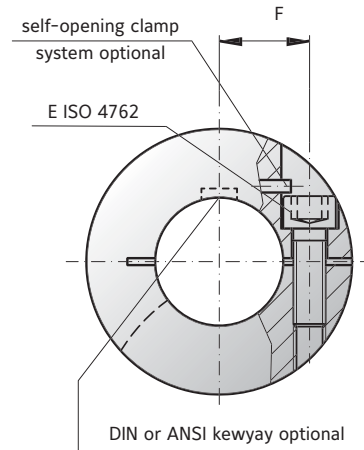
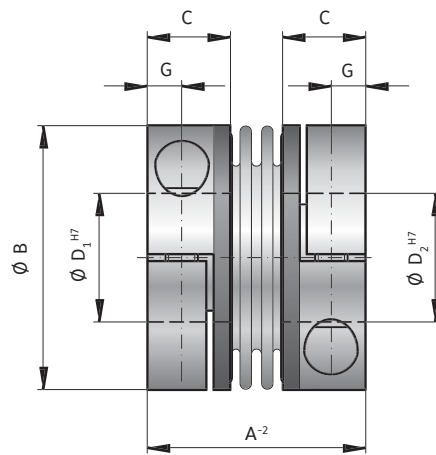
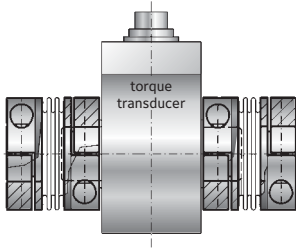

MODEL BKM

SIZE			20	200	400	1000
Rated torque (Nm)	T_{KN}		20	200	400	1000
Overall length (mm)	A^{-2}		40	59	75	89
Outside diameter (mm)	B		49	66	82	110
Fit length (mm)	C		16.5	23	27.5	34
Inside diameter possible from \emptyset to \emptyset H7 (mm)	$D_{1/2}$		15-28	24-35	32-42	40-60
Fastening screw ISO 4762			M5	M8	M10	M12
Tightening torque of the fastening screw (Nm)	E		8	40	60	130
Distance between centerlines (mm)	F		17	23	27	39
Distance (mm)	G		6	9.5	11	13
Moment of inertia (10^{-3} kgm ²)	$J_{ges.}$		0.05	0.18	0.62	7.2
Hub material			AL	AL	AL	steel
Approximate weight (kg)			0.13	0.4	0.7	3.5
Torsional stiffness (10^3 Nm/rad)	C_T		41.9	138	170	570
Axial \pm (mm)		Max. values	1	1.5	1	2
Lateral \pm (mm)			0.06	0.08	0.1	0.1
Angular \pm (degree)			0.5	0.5	0.5	0.5
Axial spring stiffness (N/mm)	C_a		55.8	153	114	148
Lateral spring stiffness (N/mm)	C_r		3,710	11,000	6,058	9,010
Speed max. with G = 2.5 balancing min ⁻¹			80,000	60,000	50,000	40,000

ORDERING EXAMPLE	BKM	20	20	19.05	XX
Model	●				Special designation only (e.g. special bore tolerance).
Size		●			
Bore D1 H7			●		
Bore D2 H7				●	
For custom features place an XX at the end of the part number and describe the special requirements (e.g. BKM/20/20/19.05/XX; XX=finely balanced for 25,000 rpm)					

BK3

WITH CONICAL CLAMPING SYSTEM 15 - 10,000 Nm

ABOUT



FEATURES

- ▶ high clamping pressure
- ▶ high torque version
- ▶ modern design for removal system

MATERIAL

- ▶ **Bellows:** high grade stainless steel
- ▶ **Hubs:** steel

DESIGN

Two conical clamping hubs concentrically mounted to flexible bellows. Brief overloads of up to 1.5x the rated torque are acceptable.

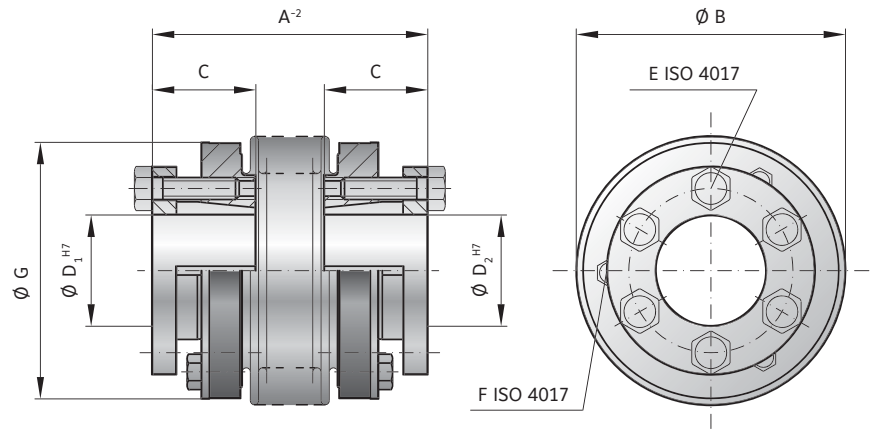

MODEL BK3

SIZE		15	30	60	150	200	300	500	800	1500	4000	6000	10000	
Rated torque (Nm)	T_{KN}	15	30	60	150	200	300	500	800	1500	4000	6000	10000	
Overall length (mm)	A^{-2}	48 55	57 65	66 76	75 87	78 90	89 103	97 110	114	141	195	210	217	
Outside diameter (mm)	B	49	55	66	81	90	110	124	133	157	200	253	303	
Fit length (mm)	C	19	22	27	32	32	41	41	50	61	80	85	92	
Inside diameter possible from \emptyset to \emptyset H7 (mm)	$D_{1/2}$	10-22	12-23	12-29	15-38	15-44	24-56	24-60	30-60	35-70	50-100	60-140	70-180	
Fastening screw ISO 4017	E	6 x M4	6 x M5	6 x M5	6 x M6	6 x M6	6 x M8	6 x M8	6 x M10	6 x M12	6 x M16	6 x M16	8 x M16	
Tightening torque of the fastening screw (Nm)		4	6	8	12	14	18	25	40	70	120	150	160	
Jack screw ISO 4017	F	3 x M4	3 x M4	3 x M5	3 x M5	3 x M6	3 x M6	3 x M6	3 x M8	6 x M8	6 x M10	6 x M10	8 x M10	
Outside diameter of hub (mm)	G	49	55	66	81	90	110	122	116	135	180	246	295	
Moment of inertia (10^{-3} kgm ²)	J_{ges}	0.07 0.08	0.15 0.16	0.39 0.41	1.2 1.6	1.7 2.5	5.1 5.9	9.1 9.9	13.2	34.9	85.5	254	629	
Approximate weight (kg)		0.25	0.4	0.7	1.2	1.8	3	4.2	5.6	8.2	23	32.6	45.5	
Torsional stiffness (10^3 Nm/rad)	C_T	20 15	39 28	76 55	175 110	191 140	450 350	510 500	780	1304	3400	5700	10950	
Axial \pm (mm)	Max. values	1 2	1 2	1.5 2	2 2	3 2	2.5 3.5	2.5 3.5	3.5	3.5	3.5	3	3	
Lateral \pm (mm)		0.15 0.2	0.2 0.25	0.2 0.25	0.2 0.25	0.2 0.25	0.3 0.25	0.3 0.3	0.3 0.35	0.35	0.35	0.4	0.4	0.4
Angular \pm (degree)		1 1.5	1 1.5	1 1.5	1 1.5	1 1.5	1 1.5	1 1.5	1 1.5	1.5	1.5	1.5	1.5	1.5
Axial spring stiffness (N/mm)	C_s	25 15	50 30	72 48	82 52	90 60	105 71	70 48	100	320	565	1030	985	
Lateral spring stiffness (N/mm)	C_r	475 137	900 270	1200 420	1500 435	2040 610	3750 1050	2500 840	2000	3600	6070	19200	21800	

ORDERING EXAMPLE	BK3	60	76	20	22.23	XX
Model	●					Special designation only (e.g. non-standard bore tolerance)
Size		●				
Overall length mm			●			
Bore D1 H7				●		
Bore D2 H7					●	
For custom features place an XX at the end of the part number and describe the special requirements (e.g. BK3/60/76/20/22.23/XX; XX=K6 bore tolerance on D1)						

BK4

FOR TAPERED SHAFTS

15 - 150 Nm



ABOUT

FEATURES

- ▶ for tapered shafts
- ▶ easy to mount and dismount
- ▶ high installed concentricity

MATERIAL

- ▶ **Bellows:** high grade stainless steel
- ▶ **Hubs:** steel

DESIGN

Conical clamping system opposite 1:10 tapered bore with feather keyway. Brief overloads of up to 1.5x the rated torque acceptable.

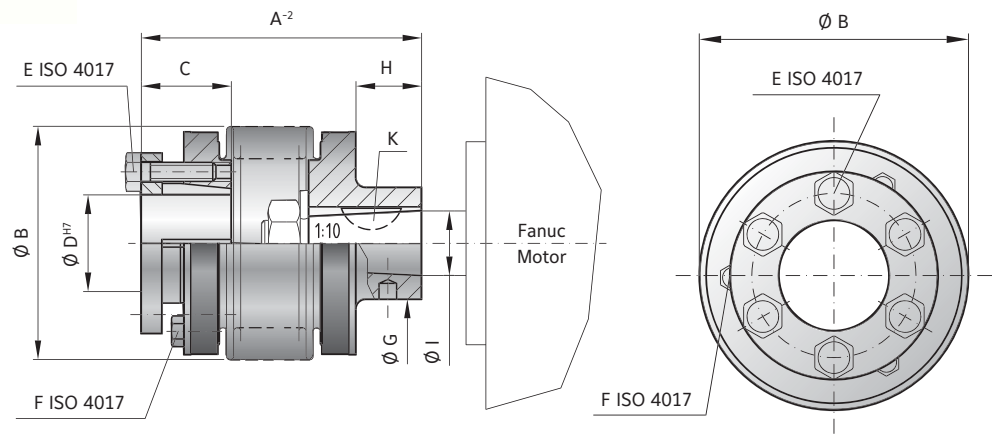

MODEL BK4

SIZE		15		30		60		150		
Rated torque	(Nm)	15		30		60		150		
Overall length	(mm)	A ⁻²	47	54	68	76	72	82	82	94
Outside diameter	(mm)	B	49		55		66		81	
Fit length	(mm)	C	19		22		27		32	
Inside diameter possible from Ø to Ø H7	(mm)	D	10-22		12-23		12-29		15-37	
Fastening screw ISO 4017		E	6 x M4		6 x M5		6 x M5		6 x M6	
Tightening torque of the fastening screw	(Nm)		4		6		8		12	
Jack screw ISO 4017		F	3 x M4		3 x M4		3 x M5		3 x M5	
Outside diameter of hub	(mm)	G	20		27		30		30	
Hub length	(mm)	H	8.5		22		18		20	
Moment of inertia	(10 ⁻³ kgm ²)	J _{ges}	0.10	0.12	0.22	0.27	0.58	0.61	1.1	1.4
Approximate weight	(kg)		0.25		0.4		0.8		1.35	
Torsional stiffness	(10 ³ Nm/rad)	C _T	20	15	39	28	76	55	175	110
Axial	± (mm)	Max. values	1	2	1	2	1.5	2	2	3
Lateral	± (mm)		0.15	0.2	0.2	0.25	0.2	0.25	0.2	0.25
Angular	± (degree)		1	1.5	1	1.5	1	1.5	1	1.5
Axial spring stiffness	(N/mm)	C _a	25	15	50	30	72	48	82	52
Lateral spring stiffness	(N/mm)	C _r	475	137	900	270	1200	420	1500	435
Cone Ø (Fanuc-Motor)	(mm)	I	11		16		16		16	
Key width	(mm)	K	4		5		5		5	

ORDERING EXAMPLE	BK4	150	82	20	XX
Model	●				Special designation only (e.g. non-standard bore tolerance)
Size		●			
Overall length mm			●		
Bore D1 H7				●	
For custom features place an XX at the end of the part number and describe the special requirements (e.g. BK4/150/82/20/XX; XX=finely balanced for 25,000 rpm)					

BELLOWS COUPLINGS BK

BK5

BLIND MATE WITH CLAMPING HUB 15 - 1,500 Nm

ABOUT

FEATURES

- ▶ easy installation and removal
- ▶ electrically and thermally isolating
- ▶ absolutely backlash free assembly

MATERIAL

- ▶ **Bellows:** high grade stainless steel
- ▶ **Hubs:** up through size 80 Aluminum, size 150 and up steel

- ▶ **Tapered male segment:** high strength plastic

DESIGN

Two clamping hubs, one of which has a tapered male projection for blind mate connection. Brief overloads of up to 1.5x the rated torque are acceptable.

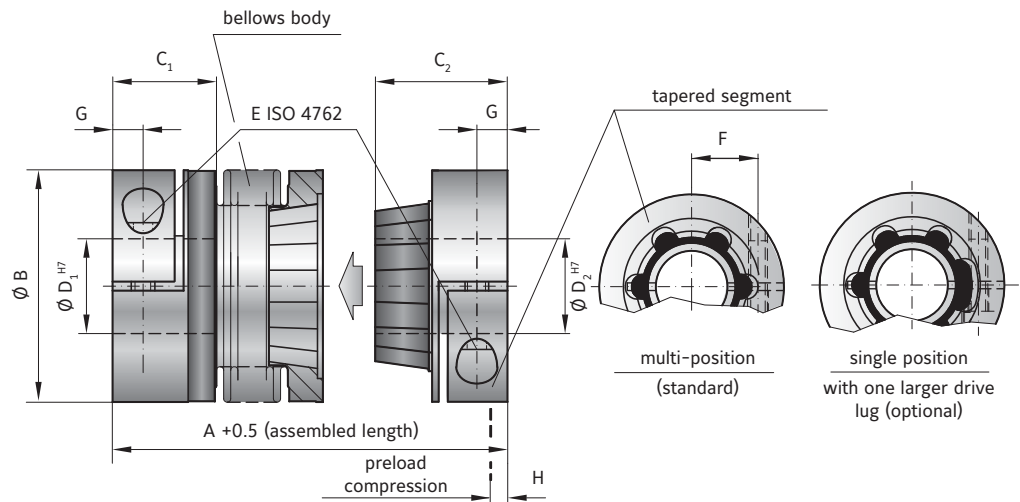

MODEL BK5

SIZE			15	30	60	80	150	300	500	800	1500
Rated torque (Nm)	T_{KN}		15	30	60	80	150	300	500	800	1500
Overall length (inserted) (mm)	$A^{+0.5}$		60 67	71 79	85 95	94 106	95 107	114 128	136 149	150 172	172
Outside diameter (mm)	B		49	55	66	81	81	110	124	133	157
Fit length (mm)	C_1		22	27	32	36	36	43	51	45	55
Fit length (mm)	C_2		28	33	39	43	43	52	61	74	94
Inside diameter possible from \emptyset to \emptyset H7 (mm)	D_1		8-28	10-30	12-32	14-42	14-42	24-60	35-60	40-75	50-80
Inside diameter possible from \emptyset to \emptyset H7 (mm)	D_2		8-22	10-25	12-32	14-38	14-38	24-58	35-60	40-62	50-75
Fastening screw ISO 4762	E		M5	M6	M8	M10	M10	M12	M16	2 x M16**	2 x M20**
Tightening torque of the fastening screw (Nm)			8	15	40	50	70	130	200	250	470
Distance between centerlines (mm)	F		17	19	23	27	27	39	41	2 x 48**	2 x 55**
Distance (mm)	G		6.5	7.5	9.5	11	11	13	16.5	18	22.5
Preload compression (mm)	H		0.2 - 1.0	0.5 - 1.0	0.5 - 1.5	0.5 - 1.5	0.5 - 1.5	0.5 - 1.5	1.0 - 2.0	1.0 - 2.5	0.5 - 1.5
Axial recovery force at maximum pretensioning (N)			20 12	50 30	70 45	48 32	82 52	157 106	140 96	200 650	650
Moment of inertia (10^{-3} kgm ²)	J_{res}		0.07 0.08	0.14 0.15	0.23 0.26	0.65 0.67	2.2 2.4	7.4 7.9	13.7 14.4	26.2 51.4	51.4
Approximate weight (kg)			0.1 0.1	0.3 0.3	0.4 0.4	0.9 0.9	1.8 1.8	4 4	6.5 6.7	8.2 15.3	15.3
Torsional stiffness (10^3 Nm/rad)	C_t		10 8	20 14	38 28	65 43	88 55	225 175	255 245	400 650	650
Axial* \pm (mm)	Max. values		0.5 1	0.5 1	0.5 1	1 1	2 1	2 1.5	2 2.5	3.5 3	2
Lateral \pm (mm)			0.15 0.2	0.2 0.25	0.2 0.25	0.2 0.25	0.2 0.25	0.2 0.25	0.25 0.3	0.3 0.35	0.35 0.35
Angular \pm (degree)			1 1.5	1 1.5	1 1.5	1 1.5	1 1.5	1 1.5	1 1.5	1 1.5	1.5 1.5
Lateral spring stiffness (N/mm)	C_r		475 137	900 270	1200 420	920 290	1550 435	3750 1050	2500 840	2000 3600	3600

*in addition to maximum allowable pretension **180° opposed in each clamping hub.

ORDERING EXAMPLE	BK5	30	71	18	19	XX
Model	●					
Size		●				
Overall length mm			●			
Bore D1 H7				●		
Bore D2 H7					●	
For custom features place an XX at the end of the part number and describe the special requirements (e.g. BK5/30/71/18/19/XX; XX=finely balanced for 25,000 rpm)						

BK6

BLIND MATE WITH CONICAL CLAMPING RING

15 - 1,500 Nm

ABOUT



FEATURES

- ▶ axial mounting possible
- ▶ easy installation and removal
- ▶ naturally very well balanced due to self centering clamping ring system
- ▶ absolutely backlash free assembly

MATERIAL

- ▶ **Bellows:** high grade stainless steel
- ▶ **Hubs:** steel

- ▶ **Tapered male segment:** high strength plastic

DESIGN

Two conical clamping ring hubs, one of which has a tapered male projection for blind mate connection. Brief overloads of up to 1.5x the rated torque are acceptable.

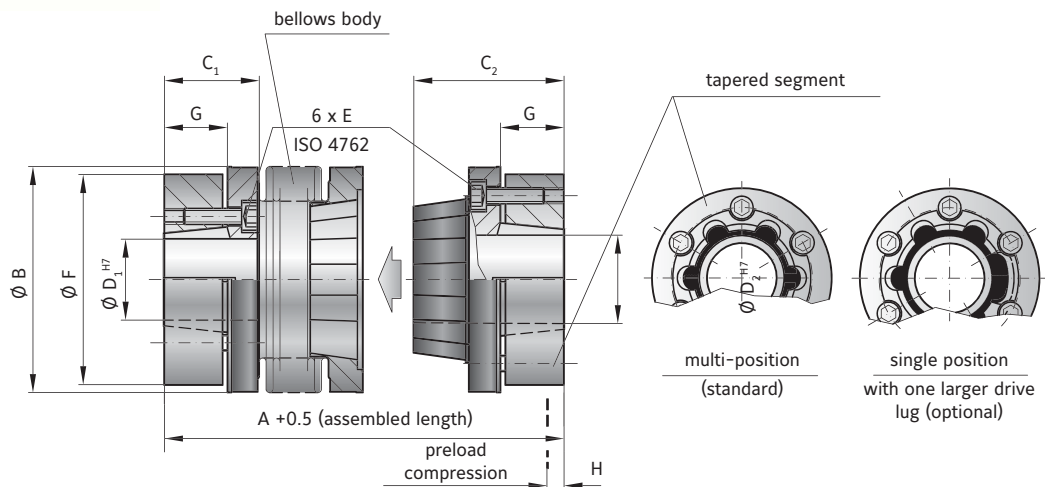

MODEL BK6

SIZE			15	30	60	150	300	500	800	1500
Rated torque (Nm)	T_{KN}		15	30	60	150	300	500	800	1500
Overall length (gesteckt) (mm)	$A^{+0.5}$		58, 65	68, 76	79, 89	97, 109	113, 127	132, 145	140, 158	
Outside diameter (mm)	B		49	55	66	81	110	124	133	157
Fit length (mm)	C_1		13.5	16.5	18	23.5	27	32	42	53
Fit length (mm)	C_2		29	34	39	49.5	59	68	74	90.5
Inside diameter possible from \emptyset to $\emptyset H7$ (mm)	D_1		10-22	12-24	12-32	15-40	24-56	30-60	40-62	50-75
Inside diameter possible from \emptyset to $\emptyset H7$ (mm)	D_2		10-22	12-24	12-32	15-40	24-56	30-60	40-62	50-75
Fastening screw ISO 4762			M4	M5	M5	M6	M8	M8	M10	M12
Tightening torque of the fastening screw (Nm)	E		3.5	6.5	8	12	30	32	55	110
Diameter of clamping ring (mm)	F		46.5	51	60	74	102	114	126	146
Clamping ring length (mm)	G		9.5	10.5	11.5	17.5	20	23	27	32
Preload compression (mm)			0.2 - 1.0	0.5 - 1.0	0.5 - 1.5	0.5 - 1.5	0.5 - 1.5	1.0 - 2.0	1.0 - 2.0	0.5 - 1.5
Axial recovery force at maximum pretensioning (N)	H		20, 12	50, 30	70, 45	82, 52	157, 106	140, 96	400, 250	650, 400
Moment of inertia (10^{-3} kgm^2)	J_{ges}		0.1, 0.12	0.2, 0.25	0.4, 0.45	2.0, 2.5	5.4, 6.1	8.4, 9.1	19.5, 16.2	44, 33
Approximate weight (kg)			0.3, 0.32	0.5, 0.52	0.82, 0.84	1.6, 1.7	4.1, 4.2	6.0, 6.3	9.4, 9.4	16.2, 16.2
Torsional stiffness (10^3 Nm/rad)	C_T		10, 8	20, 14	38, 28	88, 55	225, 175	255, 245	400, 400	660, 660
Axial* \pm (mm)			0.5, 1	0.5, 1	0.5, 1	1, 1	2, 1.5	2, 2.5	3.5, 3	2, 2
Lateral \pm (mm)	Max. values		0.15, 0.2	0.2, 0.25	0.2, 0.25	0.2, 0.25	0.25, 0.3	0.3, 0.35	0.35, 0.35	0.35, 0.35
Angular \pm (degree)			1, 1.5	1, 1.5	1, 1.5	1, 1.5	1, 1.5	1, 1.5	1.5, 1.5	1.5, 1.5
Lateral spring stiffness (N/mm)	C_r		475, 137	900, 270	1200, 420	1550, 435	3750, 1050	2500, 840	2000, 2000	3600, 3600

* in addition to maximum allowable pretension

Higher torques upon request

ORDERING EXAMPLE	BK6	30	76	18	19	XX
Model	●					
Size		●				
Overall length mm			●			
Bore D1 H7				●		
Bore D2 H7					●	
For custom features place an XX at the end of the part number and describe the special requirements (e.g. BK6/30/76/18/19/XX; XX=finely balanced for 25,000 rpm)						

Special designation only (e.g. special bore tolerance).

BK7

WITH EXPANDING SHAFT

15 - 300 Nm



ABOUT

FEATURES

- ▶ for hollow shaft mounting
- ▶ short design saves installation space
- ▶ solution for mismatched shaft / bore

MATERIAL

- ▶ **Bellows:** high grade stainless steel
- ▶ **Hubs:** see table
- ▶ **Expanding mandrel system:** steel

DESIGN

One clamping hub on one end with an expanding shaft on the other end. Brief overloads of up to 1.5x the rated torque are acceptable.

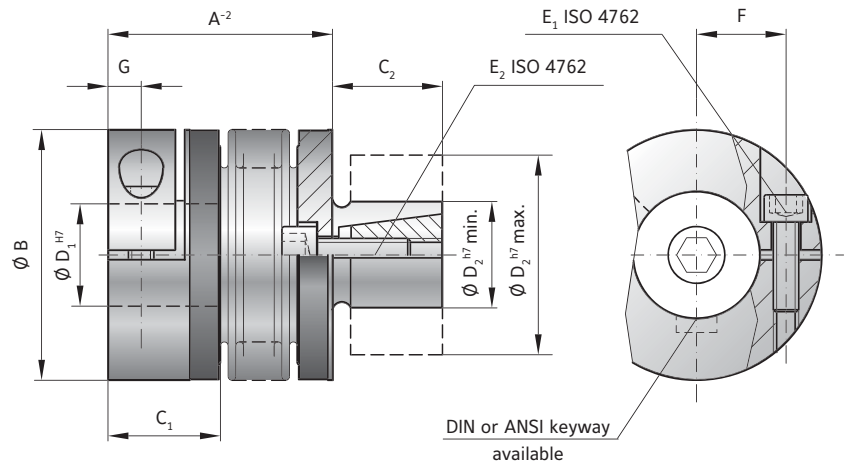

MODEL BK7

SIZE		15		30		60		150		300		
Rated torque	(Nm)	T_{KN}	15	30	60	150	300					
Overall length	(mm)	A^{-2}	45	52	53	61	62	72	71	83	84	98
Outside diameter	(mm)	B	49	55	66	81	110					
Fit length	(mm)	C_1	22	27	32	36	43					
Fit length	(mm)	C_2	20	25	27	32	45					
Inside diameter possible from \emptyset to \emptyset H7	(mm)	D_1	8-28	10-30	12-35	19-42	30-60					
Shaft diameter from \emptyset to \emptyset h7	(mm)	D_2	13-25	14-30	23-38	26-42	38-60					
Fastening screw ISO 4762		$E_{1/2}$	M5	M6	M8	M10	M12					
Tightening torque of the fastening screw	(Nm)	$E_{1/2}$	8	14	38	65	120					
Distance between centerlines	(mm)	F	17	19	23	27	39					
Distance	(mm)	G	6.5	7.5	9.5	11	13					
Moment of inertia (10^{-3} kgm ²)		J_{ges}	0.07	0.08	0.14	0.15	0.23	0.26	2.2	2.4	6.5	8.9
Hub material			Al	Al	Al	steel	steel					
Approximate weight	(kg)		0.15	0.3	0.4	1.7	4					
Torsional stiffness (10^3 Nm/rad)		C_T	20	15	39	28	76	55	175	110	450	350
Axial \pm (mm)		Max. values	1	2	1	2	1.5	2	2	3	2.5	3.5
Lateral \pm (mm)			0.15	0.2	0.2	0.25	0.2	0.25	0.2	0.25	0.25	0.3
Angular \pm (degree)			1	1.5	1	1.5	1	1.5	1	1.5	1	1.5
Axial spring stiffness	(N/mm)	C_a	20	12	50	30	72	48	82	52	105	71
Lateral spring stiffness	(N/mm)	C_r	315	108	730	230	1200	380	1550	435	3750	1050

ORDERING EXAMPLE	BK7	150	71	32	22.23	XX
Model	●					
Size		●				
Overall length mm			●			
Bore D1 H7				●		
Shaft D2 f7					●	
Special designation only (e.g. special bore tolerance).						

For custom features place an XX at the end of the part number and describe the special requirements (e.g. BK7/150/71/32/22.23/XX; XX=finely balanced for 25,000 rpm)

BK8

WITH ISO FLANGE CONNECTION 50 - 2,600 Nm

ABOUT

FEATURES

- ▶ for ISO flange output gearboxes
- ▶ allows for continuous hollow through axis with some right angle gearbox designs
- ▶ compact design

MATERIAL

- ▶ **Bellows:** high grade stainless steel

- ▶ **Hubs:** up through size 300 aluminum, size 1500 and up steel
- ▶ **Adapter flange:** steel

DESIGN

One clamping hub on one end with an integral flange and adapter flange on the other end. Maximum transmittable torque depends on the bore diameter.

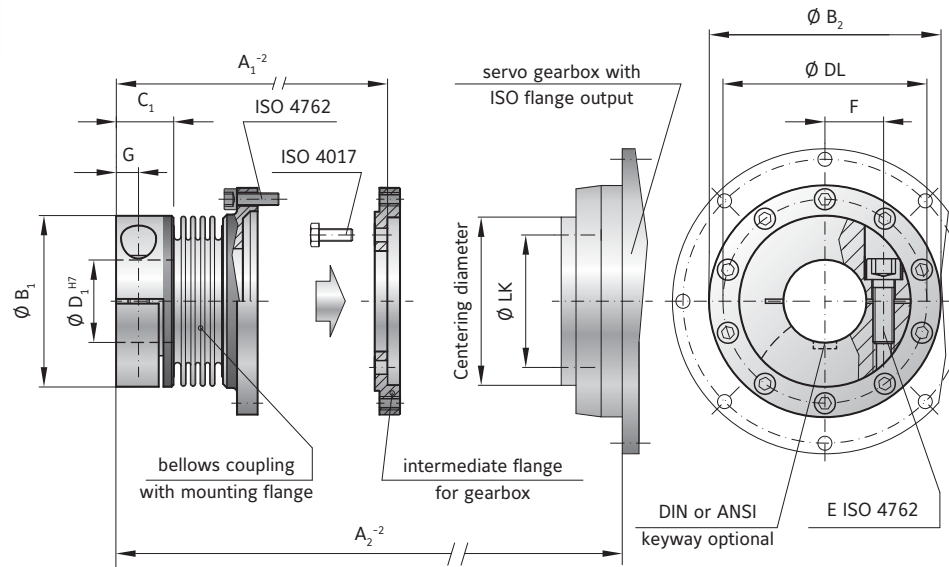

MODEL BK8

SIZE		15	60	150	300	1500
Flange centering diameter	(mm)	40 h7	63 h7	80 h7	100 h7	160 h7
Flange bolt circle / thread ϕ	(mm)	31.5 / 8 x M5	50 / 8 x M6	63 / 12 x M6	80 / 12 x M8	125 / 12 x M10
Maximum torque*	(Nm)	50	210	380	750	2600
Length -2	(mm) A ₁	48.5	67	72	90	140
Length -2	(mm) A ₂	68	97	101	128	190
Outside diameter of hub	(mm) B ₁	49	66	82	110	157
Flange diameter	(mm) B ₂	63.5	86	108	132	188
Fit length	(mm) C ₁	16.5	23	27.5	34	55
Inside diameter possible from ϕ to ϕ H7	(mm) D ₁	12-28	14-35	19-42	24-60	50-80
Hub bolt circle	(mm) DL	56.5	76	97	120	170
Fastening threads	(mm)	10 x M4	10 x M5	10 x M6	12 x M6	18 x M8
Fastening screws ISO 4762		1 x M5	1 x M8	1 x M10	1 x M12	2 x M20
Tightening torque of the fastening screw	(Nm) E ₁	8	45	80	120	470
Distance between centerlines	(mm) F	1 x 17.5	1 x 23	1 x 27	1 x 39	2 x 55
Distance	(mm) G	6.5	9.5	11	13	22.5
Approximate weight	(kg)	0.3	0.7	1	2.8	10
Moment of inertia	(10 ⁻³ kgm ²) J _{ges}	0.15	0.65	1.3	5.5	45
Lateral	\pm (mm)	0.25	0.25	0.25	0.25	0.25
Angular	\pm (degree) Max. values	1	1	1	1	1
Axial	\pm (mm)	1	1.5	2	2.5	3

* maximum torque transmittable only for brief periods and requires maximum bore for clamping strength

ORDERING EXAMPLE	BK8	60	22.23	67	XX
Model	●				
Size		●			
Bore D1 H7			●		
Overall length mm				●	
For custom features place an XX at the end of the part number and describe the special requirements (e.g. BK8/60/22.23/67/XX; XX=anodized hubs)					

Special designation only (e.g. special bore tolerance).

BK1

WITH FLANGE MOUNTING

15 - 10,000 Nm



ABOUT

FEATURES

- ▶ For simple flange mounting to special drive components
- ▶ custom flange patterns available

MATERIAL

- ▶ **Bellows:** high grade stainless steel

- ▶ **Hubs:** steel

DESIGN

Two mounting flanges concentrically assembled to the flexible bellows. Brief overloads of up to 1.5x the rated torque are acceptable.

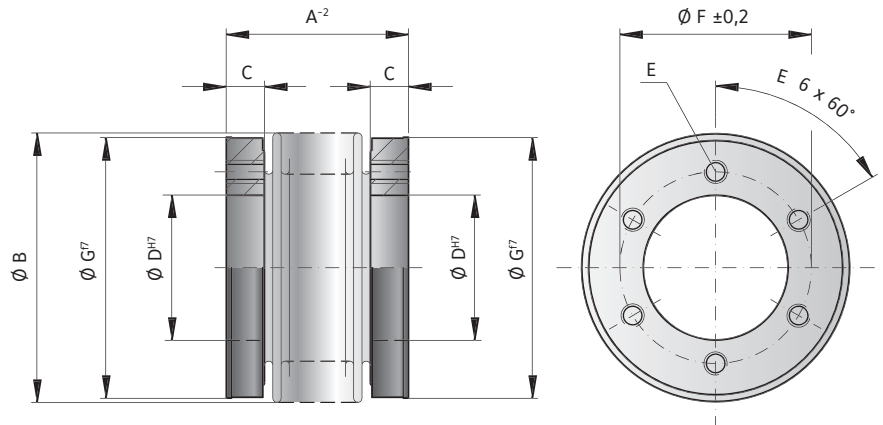

MODEL BK1

SIZE			15	30	60	150	200	300	500	800	1500	4000	6000	10000							
Rated torque (Nm)	T_{KN}		15	30	60	150	200	300	500	800	1500	4000	6000	10000							
Overall length (mm)	A^2		30 37	36 44	43 53	50 62	53 65	56 70	64 77	81	100	145	138	150							
Outside diameter of bellows (mm)	B		49	55	66	81	90	110	124	133	157	200	253	303							
Fit length/thread depth (mm)	C		7.5	10	11	13	14.5	15	16	18	22	30	30	36							
Inside diameter H7 (mm)	D		25	28	38	50	58	65	70	75	85	100	145	190							
Fastening threads	E		6 x M5	6 x M5	6 x M6	6 x M6	6 x M6	6 x M8	6 x M8	6 x M10	6 x M16	6 x M20	8 x M20	8 x M24							
Bolt circle diameter ± 0.2 (mm)	F		35	37	46	62	70	80	94	90	110	140	190	234							
Outside diameter f7 (mm)	G		49	55	66	81	90	110	122	116	140	182	235	295							
Moment of inertia (10^{-3} kgm ²)	J_{ges}		0.07 0.08	0.14 0.15	0.30 0.32	0.90 0.95	1.30 1.40	1.95 2.10	3.0 3.4	4.3	10.6	46	132	350							
Approximate weight (kg)			0.15	0.2	0.3	0.6	0.8	1.35	1.8	1.9	3.3	8.9	13.9	23.7							
Torsional stiffness (10^3 Nm/rad)	C_T		20 15	39 28	76 55	175 110	191 140	450 350	510 500	780	1304	3400	5700	10950							
Axial ± (mm)		Max. values	1 2	1 2	1.5 2	2 3	2 3	2.5 3.5	2.5 3.5	3.5	3.5	3.5	3	3							
Lateral ± (mm)			0.15 0.2	0.2 0.25	0.2 0.25	0.2 0.25	0.25 0.3	0.25 0.3	0.3 0.35	0.35	0.35	0.35	0.4	0.4	0.4						
Angular ± (degree)			1 1.5	1 1.5	1 1.5	1 1.5	1 1.5	1 1.5	1 1.5	1 1.5	1.5	1.5	1.5	1.5	1.5						
Axial spring stiffness (N/mm)	C_s		25	15	50	30	72	48	82	52	90	60	105	71	70	48	100	320	565	1030	985
Lateral spring stiffness (N/mm)	C_r		475	137	900	270	1200	420	1550	435	2040	610	3750	1050	2500	840	2000	3600	6070	19200	21800

ORDERING EXAMPLE	BK1	150	62	XX
Model	●			
Size		●		
Overall length mm			●	
Special designation only (e.g. high speed balancing).				
For custom features place an XX at the end of the part number and describe the special requirements (e.g. BK1/150/62/XX; XX=finely balanced for 25,000 rpm)				



SPECIAL SOLUTIONS

2 - 10,000 Nm

CUSTOMER SPECIFIC FEATURES

Including:

- ▶ Special materials and treatments
- ▶ Custom bellows
- ▶ Specific overall length
- ▶ Internal catches for in case of bellows rupture
- ▶ Many more

Contact us by phone at 1-630-521-9911

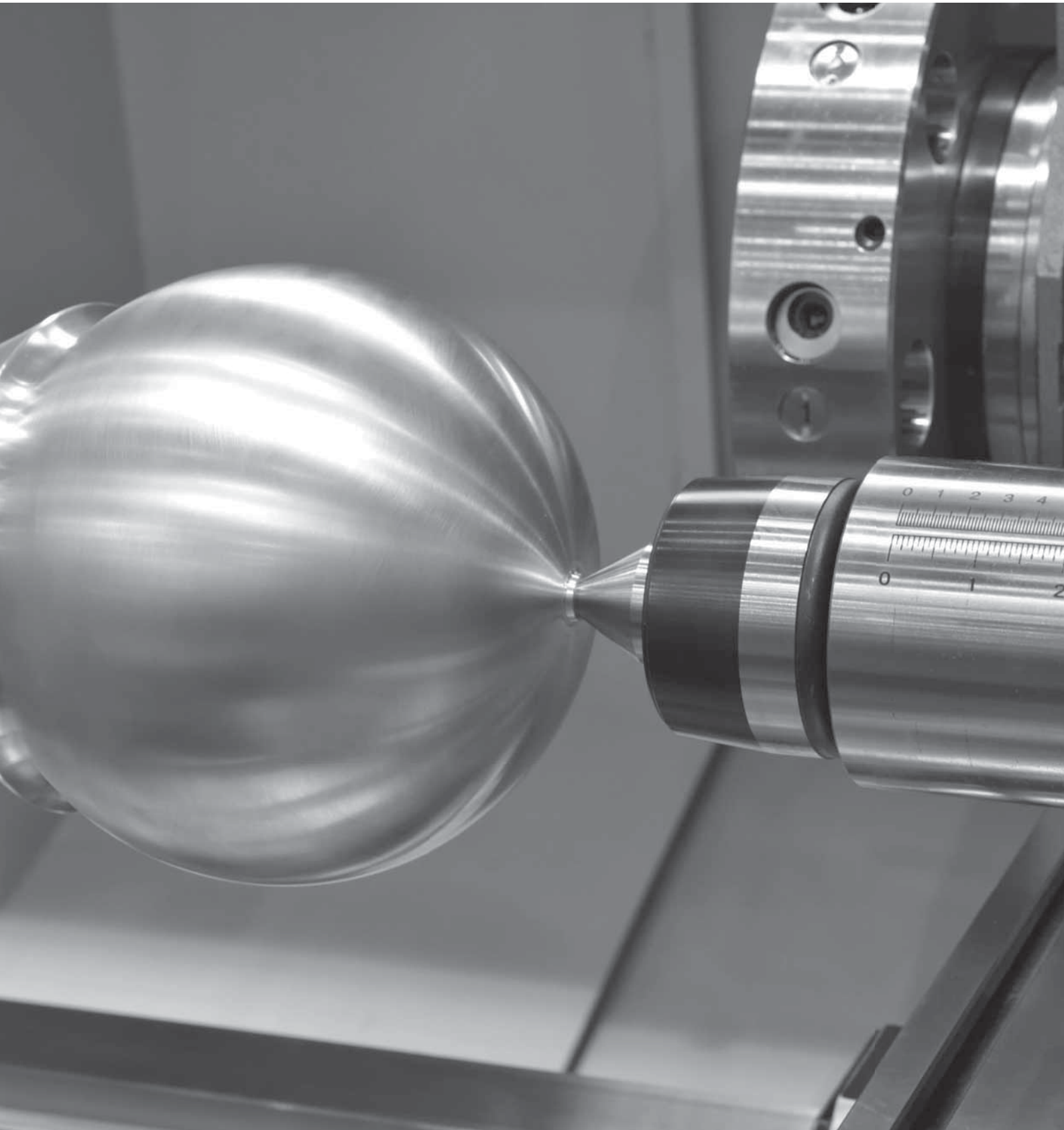



SIZES FROM 0.05- 10 Nm BACKLASH FREE MINIATURE METAL BELLOWS COUPLINGS

GENERAL INFORMATION ABOUT R+W MINIATURE BELLOWS COUPLINGS:



SERVICE LIFE

R+W bellows couplings are fatigue resistant and wear free for an infinite service life, as long as the technical limits are not exceeded.

FIT CLEARANCE

Overall shaft / hub clearance of 0.01 - 0.05 mm

ROTATIONAL SPEED

Standard up to 10,000 rpm.
Over 10,000 rpm in finely balanced version; up to grade ISO G=2.5 is available.

TEMPERATURE RANGE

-30 to +110° C

SPECIAL SOLUTIONS





Various materials, tolerances, dimensions and performance ratings available for custom applications on request.

ATEX (Optional)

For use in hazardous zones 1/21 and 2/22, the metal bellows has been authorized under directive 94/9/EG and is available with certification.

BACKLASH FREE, TORSIONALLY STIFF MINIATURE COUPLINGS

SIZES FROM 0.05 - 10 Nm

MODEL		FEATURES	
MK1		<p>with radial set screws from 0.05 - 10 Nm</p> <ul style="list-style-type: none"> ▶ large bores available in small size ▶ integral dismounting groove eliminates the need for flats on shafts ▶ economy design 	Page 52
MK2		<p>with clamping hub from 0.5 - 10 Nm</p> <ul style="list-style-type: none"> ▶ easy mounting ▶ for highly dynamic applications ▶ finely balanced versions up to 90,000 rpm 	Page 53
MKH		<p>with fully split clamping hub from 0.5 - 10 Nm</p> <ul style="list-style-type: none"> ▶ lateral mounting possible ▶ easy installation and removal ▶ allows for pre-alignment of shafts 	Page 54
MK3		<p>with expanding shaft from 0.5 - 10 Nm</p> <ul style="list-style-type: none"> ▶ easy installation ▶ solution for mismatched shaft / bore diameters ▶ saves space and cost 	Page 55
MK4		<p>with radial set screw and blind mate connection from 0.5 - 10 Nm</p> <ul style="list-style-type: none"> ▶ axial installation possible ▶ electrically and thermally isolating ▶ includes integral dismounting groove 	Page 56

MODEL

FEATURES

MK5		<p>with clamping hub and blind mate connection from 0.5 - 10 Nm</p> <ul style="list-style-type: none"> ▶ axial installation possible ▶ electrically and thermally isolating ▶ easy mounting and dismounting 	Page 57
MK6		<p>with expanding shaft and blind mate connection from 0.5 - 10 Nm</p> <ul style="list-style-type: none"> ▶ full axial installation possible ▶ well suited to restricted installation space ▶ solution to mismatched bore / shaft diameters 	Page 58
MKS		<p>with conical clamping ring assemblies from 4.5 - 10 Nm</p> <ul style="list-style-type: none"> ▶ speeds up to 120,000 rpm ▶ naturally very well balanced due in part to self centering clamping system ▶ for high speed high precision applications 	Page 59
BKL		<p>with clamping hub up to 3 Nm</p> <ul style="list-style-type: none"> ▶ low priced ▶ light weight and low moment of inertia ▶ temperatures up to 200° C 	Page 60
FK1		<p>with radial set screw up to 1 Ncm</p> <ul style="list-style-type: none"> ▶ well balanced ▶ sterilizable 	Page 61

MK1

WITH RADIAL SET SCREWS

0.05 - 10 Nm



ABOUT

FEATURES

- ▶ integral dismounting groove eliminates the need for flats on shafts
- ▶ economical design
- ▶ larger bore diameters in a small size possible

▶ **Hubs:** aluminium

DESIGN

Two hubs with radial set screws concentrically mounted to flexible bellows. Speeds up to 20,000 rpm; over 20,000 with finely balanced version.

MATERIAL

- ▶ **Bellows:** size 0.5 tombac; sizes 1 and up high grade stainless steel

Advantage:

Bore diameters above 4mm have an integral dismounting groove, which provides clearance over any burr which may be kicked up by the set screw, eliminating the need for flats on shafts.

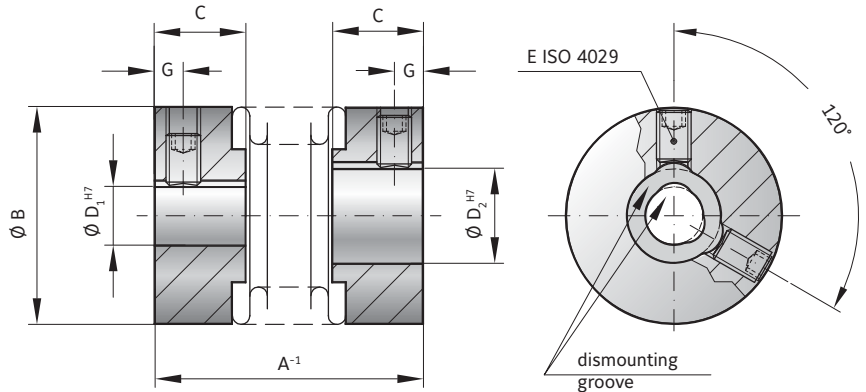
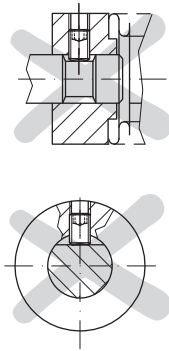

MODEL MK1

SIZE			0.5	1	5	10	15	20	45	100
Rated torque	(Nm)	T _{KN}	0.05	0.1	0.5	1.0	1.5	2.0	4.5	10
Overall length	(mm)	A ⁻¹	14	20	20 23 26	22 25 28	24 29	26 31 35	37 45	43 53
Outside diameter	(mm)	B	6.5	10	15	15	19	25	32	40
Fit length	(mm)	C	4	5	6.5	6.5	7.5	11	13	15
Inside diameter possible from Ø to Ø H7	(mm)	D _{1/2}	1-3	1-5	3-9	3-9	3-12	3-16	6-22	6-28
Clamping screw ISO 4029		E	1xM2	1xM2.5	1xM3	1xM3	2xM3	2xM4	2xM5	2xM6
Tightening torque of the fastening screw	(Nm)	E	0.35	0.75	1.3	1.3	1.3	2.5	4	6
Distance	(mm)	G	1.5	1.8	2	2	2	2.5	3.5	4
Moment of inertia	(gcm ²)	J _{ges.}	0.1	0.4	1.1 1.2 1.3	1.3 1.8 2	4.7 5.5 15	18 20 65	70 180 220	
Approximate weight	(g)		1	5	6 6 6	6 7 8	12 14 22	24 26 54	58 106 114	
Torsional stiffness	(Nm/rad)	C _T	50	70	280 210 170	510 380 320	750 700 1200	1300 1200 7000	5000 9050 8800	
Axial	(mm)	Max. values	0.4	0.4	0.4 0.5 0.6	0.4 0.5 0.6	0.5 0.7 0.5	0.6 0.7 0.7	1 1 1.2	
Lateral	(mm)		0.1	0.15	0.15 0.2 0.25	0.15 0.2 0.25	0.15 0.2 0.2	0.2 0.25 0.2	0.2 0.25 0.2	0.2 0.25 0.3
Angular	(degree)		1	1	1 1.5 2	1 1.5 2	1.5 1.5 1.5	1.5 1.5 2	1.5 2 1.5	2 1.5 2

ORDERING EXAMPLE	MK1	5	26	4.76	5	XX
Model	●					Special designation only (e.g. high speed balancing).
Size		●				
Overall length mm			●			
Bore D1 H7				●		
Bore D2 H7					●	

For custom features place an XX at the end of the part number and describe the special requirements (e.g. MK1/5/26/4.76/5/XX; XX=finely balanced for 25,000 rpm)

MK2

WITH CLAMPING HUB

0.5 - 10 Nm



ABOUT

FEATURES

- ▶ for highly dynamic applications
- ▶ easy installation
- ▶ light weight and low moment of inertia

MATERIAL

- ▶ **Bellows:** high grade stainless steel
- ▶ **Hubs:** aluminium

DESIGN

Two clamping hubs concentrically mounted to flexible bellows.

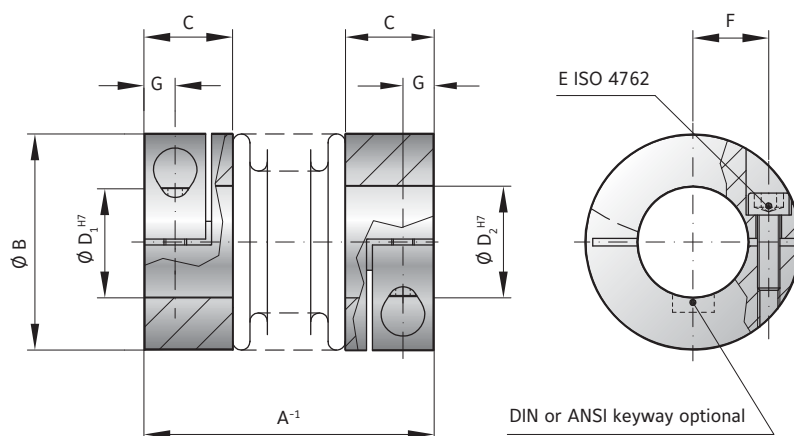

MINIATURE COUPLINGS MK

MODEL MK2

SIZE		5			10			15		20			45		100	
Rated torque (Nm)	T_{KN}	0.5			1.0			1.5		2.0			4.5		10	
Overall length (mm)	A^{-1}	25	28	31	27	30	33	30	35	35	40	44	46	54	50	60
Outside diameter (mm)	B	15			15			19		25			32		40	
Fit length (mm)	C	9			9			11		13			16		16	
Inside diameter possible from \emptyset to \emptyset H7 (mm)	$D_{1/2}$	3-7			3-7			3-8		3-12.7			5-16		5-24	
Fastening screw ISO 4762	E	M2			M2			M2.5		M3			M4		M4	
Tightening torque of the fastening screw (Nm)		0.43			0.43			0.85		2.3			4		4.5	
Distance between centerlines (mm)	F	4.5			4.5			6		8			10		15	
Distance (mm)	G	3			3			3.5		4			5		5	
Moment of inertia (gcm^2)	J_{ges}	2.6	2.8	3	3	3.4	3.6	8.5	9.5	25	27	29	100	108	160	205
Approximate weight (g)		9	9	9	9	10	11	22	24	36	38	40	74	78	120	130
Torsional stiffness (Nm/rad)	C_T	280	210	170	510	380	320	750	700	1200	1300	1200	7000	5000	9050	8800
Axial (mm)	Max. values	0.4	0.5	0.6	0.4	0.5	0.6	0.5	0.7	0.5	0.6	0.7	0.7	1	1	1.2
Lateral (mm)		0.15	0.2	0.25	0.15	0.2	0.25	0.15	0.2	0.15	0.2	0.25	0.2	0.25	0.2	0.3
Angular (degree)		1	1.5	2	1	1.5	2	1.5	1.5	1.5	1.5	2	1.5	2	1.5	2

ORDERING EXAMPLE	MK2	5	25	4.76	5	XX
Model	●					Special designation only (e.g. special bore tolerance).
Size		●				
Overall length mm			●			
Bore D1 H7				●		
Bore D2 H7					●	

For custom features place an XX at the end of the part number and describe the special requirements (e.g. MK2/5/25/4.76/5/XX; XX=finely balanced for 25,000 rpm)

WITH FULLY SPLIT CLAMPING HUB

0.5 - 10 Nm



ABOUT

FEATURES

- ▶ mounts laterally
- ▶ allows for pre-alignment of shafts
- ▶ light weight and low moment of inertia

DESIGN

Two fully split clamping hubs, with two screws in each, concentrically mounted to flexible bellows.

MATERIAL

- ▶ **Bellows:** high grade stainless steel
- ▶ **Hubs:** aluminium

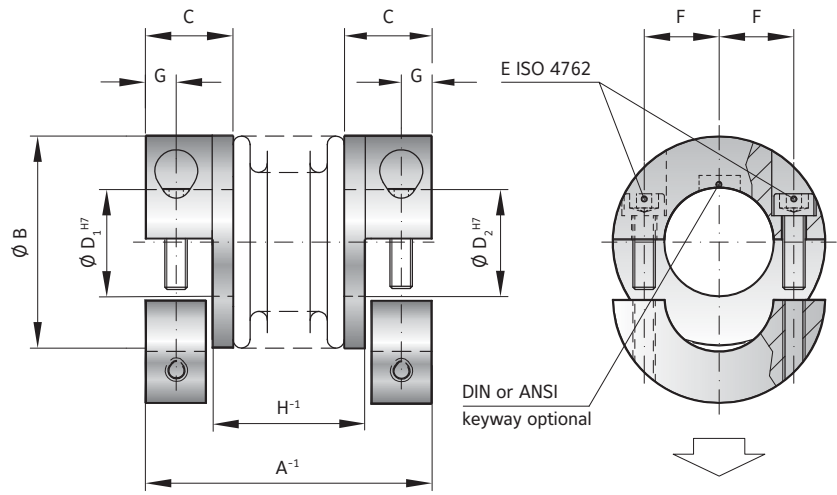

MODEL MKH

SIZE			5			10			15			20			45		100	
Rated torque (Nm)	T_{KN}		0.5			1.0			1.5			2.0			4.5		10	
Overall length (mm)	A^{-1}		25	28	31	27	30	33	30	35	35	40	44	46	54	50	60	
Outside diameter (mm)	B		15			15			19			25			32		40	
Fit length (mm)	C		9			9			11			13			16		16	
Inside diameter possible from \emptyset to \emptyset H7 (mm)	$D_{1/2}$		3-7			3-7			3-8			3-12.7			5-16		5-24	
Fastening screw ISO 4762	E		M2			M2			M2.5			M3			M4		M4	
Tightening torque of the fastening screw (Nm)			0.43			0.43			0.85			2.3			4		4.5	
Distance between centerlines (mm)	F		4.5			4.5			6			8			10		15	
Distance (mm)	G		3			3			3.5			4			5		5	
Distance (H)	H^{-1}		12	15	18	14	17	20	14.5	19.5	17	22	26	23.5	31.5	27.5	37.5	
Moment of inertia (gcm^2)	J_{ges}		2.6	2.8	3	3	3.4	3.6	8.5	9.5	25	27	29	100	108	160	205	
Approximate weight (g)			9	9	9	9	10	11	22	24	36	38	40	74	78	120	130	
Torsional stiffness (Nm/rad)	C_T		280	210	170	510	380	320	750	700	1200	1300	1200	7000	5000	9050	8800	
Axial (mm)	Max. values		0.4	0.5	0.6	0.4	0.5	0.6	0.5	0.7	0.5	0.6	0.7	0.7	1	1	1.2	
Lateral (mm)			0.15	0.2	0.25	0.15	0.2	0.25	0.15	0.2	0.15	0.2	0.25	0.2	0.25	0.2	0.3	
Angular (degree)			1	1.5	2	1	1.5	2	1.5	1.5	1.5	1.5	2	1.5	2	1.5	2	

ORDERING EXAMPLE	MKH	20	35	8	9.53	XX
Model	●					Special designation only (e.g. special bore tolerance).
Size		●				
Overall length mm			●			
Bore D1 H7				●		
Bore D2 H7					●	
For custom features place an XX at the end of the part number and describe the special requirements (e.g. MKH/20/35/8/9.53/XX; XX=finely balanced for 25,000 rpm)						

MK3

WITH EXPANDING SHAFT

0.5 - 10 Nm



ABOUT

FEATURES

- ▶ for hollow shaft mounting
- ▶ easy to install
- ▶ light weight and low moment of inertia

MATERIAL

- ▶ **Bellows:** high grade stainless steel
- ▶ **Clamping hub:** aluminium

▶ **Expanding shaft:** steel

DESIGN

One clamping hub with one clamping screw, one expanding shaft system, both concentrically mounted to flexible bellows.

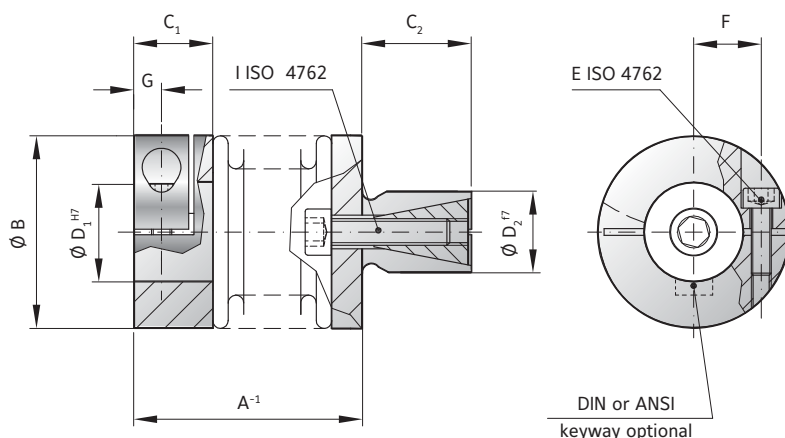

MINIATURE COUPLINGS MK

MODEL MK3

SIZE		5			10			15			20			45		100	
Rated torque (Nm)	T_{KN}	0.5			1			1.5			2			4.5		10	
Overall length (mm)	A^{-1}	20	23	26	22	25	28	24	30	27	33	36	36	44	41	51	
Outside diameter (mm)	B	15			15			19			25			32		40	
Fit length (mm)	C_1	9			9			11			13			16		16	
Shaft length (mm)	C_2	10			10			12			12			15		20	
Inside diameter possible from \emptyset to $\emptyset H7$ (mm)	D_1	3-7			3-7			4-8			4-12.7			5-16		6-24	
Standard shaft possible from \emptyset to $\emptyset f7$ (mm)	D_2	8-10			8-10			10-14			10-16			14-20		16-24	
Fastening screw ISO 4762	E	M2			M2			M2.5			M3			M4		M4	
Tightening torque of the fastening screw (Nm)		0.43			0.43			0.85			2.3			4		4.5	
Distance between centerlines (mm)	F	4.5			4.5			6			8			10		15	
Distance (mm)	G	3			3			3.5			4			5		5	
Fastening screw ISO 4762	I	M3			M3			M4			M4			M5		M6	
Tightening torque of the fastening screw (Nm)		1.5			1.5			3			4			6.5		11	
Moment of inertia (gcm^2)	$J_{ges.}$	2.6	2.8	3.0	3.0	3.4	3.6	8.5	9.5	25	27	29	100	108	160	205	
Torsional stiffness (Nm/rad)	C_T	280	210	170	510	380	320	750	700	1200	1300	1200	7000	5000	9050	8800	
Axial (mm)	Max. values	0.4	0.5	0.6	0.4	0.5	0.6	0.5	0.7	0.5	0.6	0.7	0.7	1	1	1.2	
Lateral (mm)		0.15	0.2	0.25	0.15	0.2	0.25	0.15	0.2	0.15	0.2	0.25	0.2	0.25	0.2	0.3	
Angular (degree)		1	1.5	2	1	1.5	2	1.5	1.5	1.5	1.5	2	1.5	2	1.5	2	

ORDERING EXAMPLE	MK3	20	36	6.35	12	XX
Model	●					Special designation only (e.g. special bore / shaft tolerance).
Size		●				
Overall length mm			●			
Bore D1 H7				●		
Bore D2 H7					●	
For custom features place an XX at the end of the part number and describe the special requirements (e.g. MK3/20/36/6.35/12/XX; XX=finely balanced for 25,000 rpm)						

MK4

BLIND MATE CONNECTION WITH RADIAL SET SCREWS 0.5 - 10 Nm



ABOUT

FEATURES

- ▶ easy installation and removal
- ▶ electrically and thermally isolating
- ▶ absolutely backlash free assembly

MATERIAL

- ▶ **Bellows:** high grade stainless steel
- ▶ **Hubs:** aluminium
- ▶ **Tapered male segment:** high strength plastic

DESIGN

Two hubs with radial set screws, one of which has a tapered male projection for blind mate connection. Speeds up to 20,000 rpm; over 20,000 with finely balanced version.

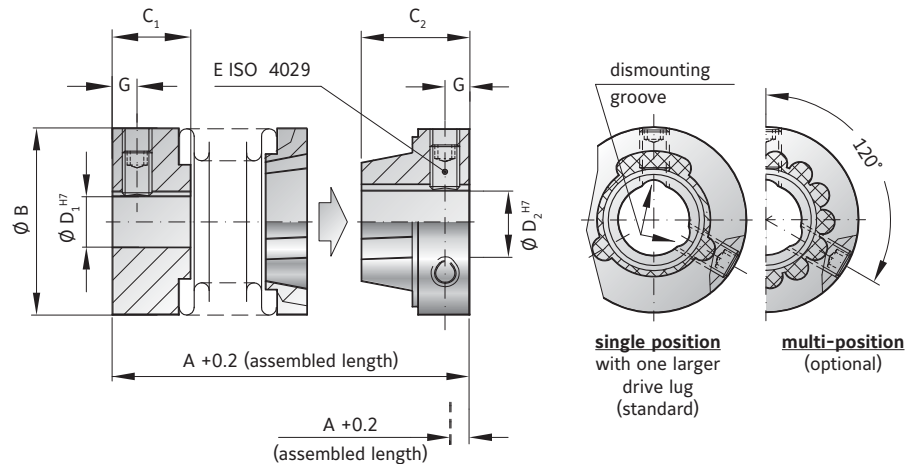

MODEL MK4

SIZE			5			15		20			45		100	
Rated torque (Nm)	T_{KN}		0.5			1.5		2			4.5		10	
Overall length (inserted) (mm)	$A^{+0.2}$		22	25	28	26	31	28	33	37	39	47	46	56
Outside diameter (mm)	B		15			19		25			32		40	
Fit length (mm)	C_1		6.5			7.5		11			13		15	
Fit length (mm)	C_2		9			10		11			14		16	
Inside diameter possible from \emptyset to \emptyset H7 (mm)	D_1		3-9			3-12		3-16			6-22		6-28	
Inside diameter possible from \emptyset to \emptyset H7 (mm)	D_2		3-6.35			3-9		3-12.7			6-16		6-20	
Clamping screw ISO 4029			1xM3			2xM3		2xM4			2xM5		2xM6	
Tightening torque of the fastening screw (Nm)	E		1.3			1.3		2.5			4		6	
Distance (mm)	G		2			2		2.5			3.5		4	
Preload compression (mm)	H		0.4			0.5		0.5			0.7		1	
Axial recovery force at max. preload compression (N)			5	3	2	4	3	3	4	3	15	10	25	30
Moment of inertia (gcm ²)	J_{ges}		2.0	2.2	2.5	5.5	6.0	21	23	25	80	85	200	210
Torsional stiffness (Nm/rad)	C_T		280	210	170	750	700	1200	1300	1200	7000	5000	9050	8800
Axial* (mm)			0.4	0.5	0.6	0.5	0.7	0.5	0.6	0.7	0.7	1	1	1.2
Lateral (mm)			0.15	0.2	0.25	0.15	0.2	0.15	0.2	0.25	0.2	0.25	0.2	0.3
Angular (degree)			1	1.5	2	1.5	1.5	1.5	1.5	2	1.5	2	1.5	2

* in addition to maximum pre-tensioning

ORDERING EXAMPLE	MK4	20	37	8	9.53	XX
Model	●					
Size		●				
Overall length mm			●			
Bore D1 H7				●		
Bore D2 H7					●	

Special designation only (e.g. special bore tolerance).

For custom features place an XX at the end of the part number and describe the special requirements (e.g. MK4/20/37/8/9.53/XX; XX=finely balanced for 25,000 rpm)

MK5

BLIND MATE CONNECTION WITH CLAMPING HUB 0.5 - 10 Nm

ABOUT



FEATURES

- ▶ easy installation and removal
- ▶ electrically and thermally isolating
- ▶ absolutely backlash free assembly

MATERIAL

- ▶ **Bellows:** high grade stainless steel
- ▶ **Hubs:** aluminium
- ▶ **Tapered male segment:** high strength plastic

DESIGN

Two clamping hubs, one of which has a tapered male projection for blind mate connection.

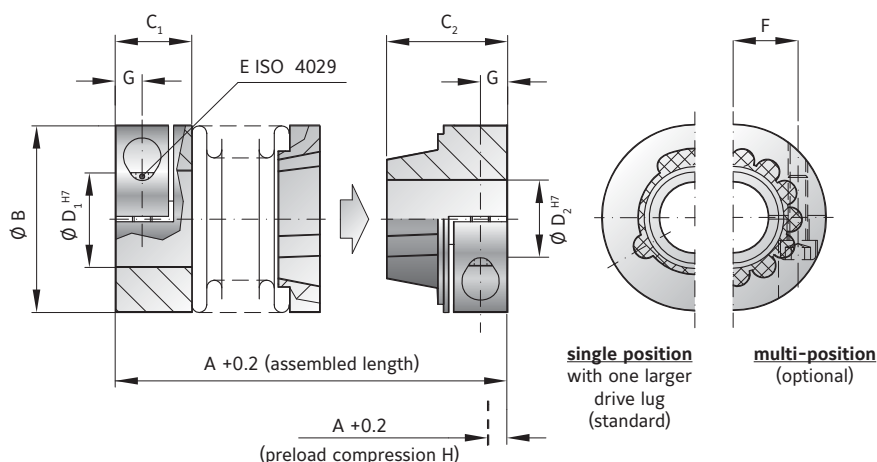

MODEL MK5

SIZE		5			15		20			45		100			
Rated torque	(Nm)	T_{KN}		0.5		1.5		2		4.5		10			
Overall length (inserted)	(mm)	$A^{+0.2}$		27	30	33	34	39	37	43	46	49	57	55	65
Outside diameter	(mm)	B		15		19		25		32		40			
Fit length	(mm)	C_1		9		11		13		16		16			
Fit length	(mm)	C_2		12		14		16		20		21.5			
Inside diameter possible from \emptyset to $\emptyset H7$	(mm)	$D_{1/2}$		3-6.35		3-8		3-12.7		5-16		5-20			
Fastening screw ISO 4762		E		M2		M2.5		M3		M4		M4			
Tightening torque of the fastening screw	(Nm)	E		0.43		0.85		2.3		4		4.5			
Distance between centerlines	(mm)	F		4.5		6		8		10		15			
Distance	(mm)	G		3		3.5		4		5		5			
Preload compression	(mm)	H		0.4		0.5		0.5		0.7		1			
Axial recovery force at max. preload compression	(N)	5	3	2	4	3	3	4	3	15	10	25	30		
Moment of inertia	(gcm ²)	J_{ges}		3.0	3.2	3.5	9.0	10	28	30	33	110	120	220	230
Torsional stiffness	(Nm/rad)	C_T		280	210	170	750	700	1200	1300	1200	7000	5000	9050	8800
Axial*	(mm)	Max. values		0.4	0.5	0.6	0.5	0.7	0.5	0.6	0.7	0.7	1	1	1.2
Lateral	(mm)	Max. values		0.15	0.2	0.25	0.15	0.2	0.15	0.2	0.25	0.2	0.25	0.2	0.3
Angular	(degree)	Max. values		1	1.5	2	1.5	1.5	1.5	1.5	2	1.5	2	1.5	2

* in addition to maximum pretensioning

ORDERING EXAMPLE	MK5	20	37	6	9.53	XX
Model	●					
Size		●				
Overall length mm			●			
Bore D1 H7				●		
Bore D2 H7					●	
For custom features place an XX at the end of the part number and describe the special requirements (e.g. MK5/20/37/6/9.53/XX; XX=finely balanced for 25,000 rpm)						

MINIATURE COUPLINGS MK

MK6

BLIND MATE CONNECTION WITH EXPANDING SHAFT 0.5 - 10 Nm

ABOUT



FEATURES

- ▶ easy installation and removal
- ▶ solution for mismatched bore / shaft diameters
- ▶ absolutely backlash free assembly

MATERIAL

- ▶ **Bel lows:** high grade stainless steel

- ▶ **Tapered male segment:** high strength plastic
- ▶ **Clamping hub:** aluminium
- ▶ **Expanding shaft:** steel

DESIGN

One clamping hub with a tapered male projection for blind mate connection and one expanding shaft system.

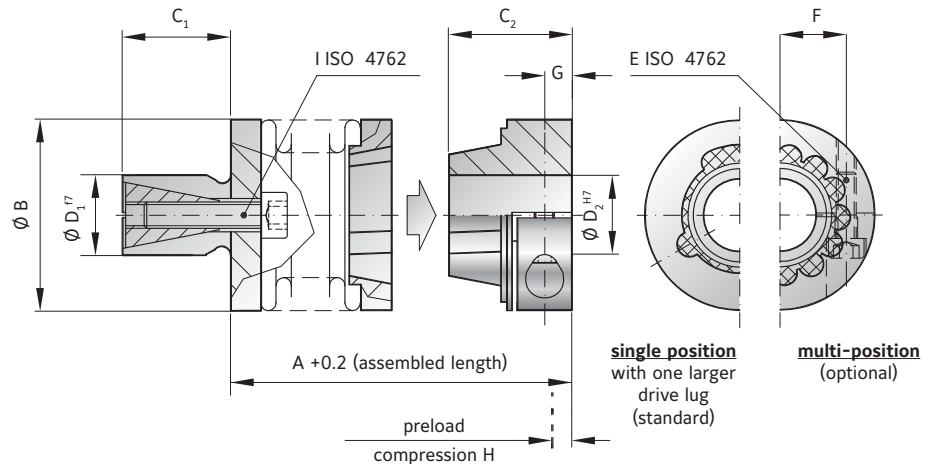

MODEL MK6

SIZE	5			15		20			45		100	
Rated torque (Nm)	0.5			1.5		2			4.5		10	
Overall length (inserted) (mm)	22	24	27	27	32	28	34	38	38	46	45	55
Outside diameter (mm)	15			19		25			32		40	
Shaft length (mm)	10			12		12			15		20	
Fit length (mm)	12			14		16			20		21.5	
Standard shaft ϕ f7 (mm)	8-10			10-14		10-16			14-20		16-24	
Inside diameter possible from ϕ to ϕ H7 (mm)	3-6.35			3-8		3-12.7			5-16		5-20	
Fastening screw ISO 4762	M2			M2.5		M3			M4		M4	
Tightening torque of the fastening screw (Nm)	0.43			0.85		2.3			4		4.5	
Distance between centerlines (mm)	4.5			6		8			10		15	
Distance (mm)	3			3.5		4			5		5	
Preload compression (mm)	0.4			0.5		0.5			0.7		1	
Axial recovery force at max. preload compression (N)	5	3	2	4	3	3	4	3	15	10	25	30
Fastening screw ISO 4762	M3			M4		M4			M5		M6	
Tightening torque of the fastening screw (Nm)	1.5			3		4			6.5		11	
Moment of inertia (gcm^2)	3.0	3.2	3.5	9.0	10	28	30	33	110	120	220	230
Torsional stiffness (Nm/rad)	280	210	170	750	700	1200	1300	1200	7000	5000	9050	8800
Lateral (mm)	0.15	0.2	0.25	0.15	0.2	0.15	0.2	0.25	0.2	0.25	0.2	0.3
Angular (degree)	1	1.5	2	1.5	1.5	1.5	1.5	2	1.5	2	1.5	2

ORDERING EXAMPLE	MK6	20	28	12	9.53	XX
Model	●					Special designation only (e.g. special bore / shaft tolerance).
Size		●				
Overall length mm			●			
Shaft D1 f7				●		
Bore D2 H7					●	
For custom features place an XX at the end of the part number and describe the special requirements (e.g. MK6/20/28/12/9.53/XX; XX=finely balanced for 25,000 rpm)						

WITH CONICAL CLAMPING RING ASSEMBLY

4.5 - 10 Nm



High speed

ABOUT

FEATURES

- ▶ made for high speed
- ▶ self centering conical clamping ring assembly
- ▶ naturally very well balanced

MATERIAL

- ▶ **Bellows:** high grade stainless steel
- ▶ **Hubs and clamping rings:** aluminium

DESIGN

Two conical clamping ring assemblies with three or four screws. Maximum speed up to 120,000 with standard balance grade ISO G=2.5.

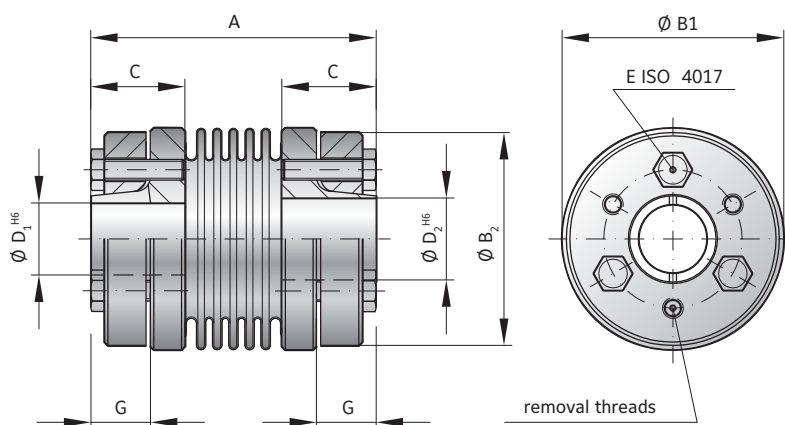

MINIATURE
COUPLINGS MK

MODEL MKS

SIZE			45	100
Rated torque	(Nm)	T_{KN}	4.5	10
Overall length	(mm)	A	42	48
Outside diameter	(mm)	B_1	32	40
Outside diameter of hub	(mm)	B_2	30	38
Fit length	(mm)	C	14	16
Inside diameter possible from \emptyset to \emptyset H6	(mm)	$D_{1/2}$	6-10	8-14
Fastening screw ISO 4017	(mm)		3x M3	4x M3
Tightening torque of the fastening screw	(Nm)	E	1.3	1.3
Distance	(mm)	G	8.5	9.5
Moment of inertia	(gcm ²)	$J_{ges.}$	65	160
Masse	(g)		51	75
Torsional stiffness	(Nm/rad)	C_T	7000	9050
Axial	(mm)		0.5	0.75
Lateral	(mm)	Max. values	0.1	0.05*
Angular	(degree)		0.5	0.5

For speeds beyond 50,000 rpm use reduced misalignment values marked with *

ORDERING EXAMPLE	MKS	45	8	9.53	XX
Model	●				
Size		●			
Bore D1 H6			●		
Bore D2 H6				●	
Special designation only (e.g. special bore tolerance).					
For custom features place an XX at the end of the part number and describe the special requirements (e.g. MKS/45/8/9.53/XX; XX=anodized aluminum hubs)					

BKL/003

ECOFLEX® WITH CLAMPING HUB 3 Nm



ABOUT

FEATURES

- ▶ economically priced
- ▶ backlash free and torsionally stiff
- ▶ wear free and robust

DESIGN

Two clamping hubs, each with a clamping screw.
Operational from -40 to +200° C

MATERIAL

- ▶ **Bellows:** high grade stainless steel
- ▶ **Hubs:** aluminium

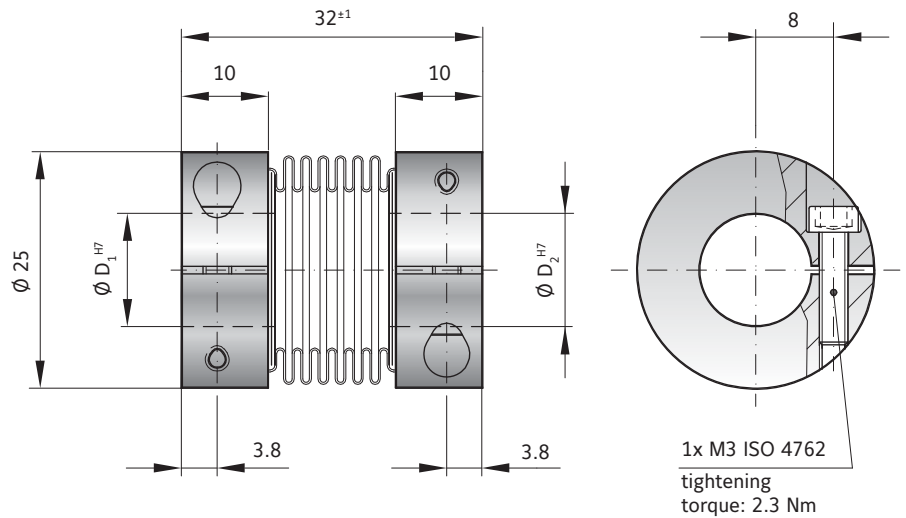

MODEL BKL/003

SIZE			3
Rated torque	(Nm)	T_{KN}	3
Standard bore diameters H7	(mm)	D_1, D_2	3 to 12.7
Moment of inertia	(gcm ²)	$J_{ges.}$	20
Approximate weight	(g)		23
Tightening torque of the fastening screws	(Nm)		2.3
Torsional stiffness	(Nm/rad)	C_T	994
Axial	(mm)	Max. values	1
Lateral	(mm)		0.2
Angular	(degree)		2

ECOFLEX®:
The low cost alternative for encoders, potentiometers, stepper motors, and small servo drives.

ORDERING EXAMPLE	BKL	003	3	6.35	XX
Model	●				
Size		●			
Bore D1 H7			●		
Bore D2 H7				●	

Special designation only (e.g. special bore tolerance).

For custom features place an XX at the end of the part number and describe the special requirements (e.g. BKL/003/3/6.35/XX; XX=stainless steel hubs)

FK1

MICROFLEX WITH RADIAL SET SCREWS

1 Ncm

ABOUT

FEATURES

- ▶ very small dimensions
- ▶ backlash free
- ▶ vibration damping

MATERIAL

- ▶ **Flex element:** high strength Polyamide
- ▶ **Hubs:** stainless steel

DESIGN

Two hubs with set screws mounted to a flex beam segment. Operational from -35° to +80° C. Speeds up to 20,000 rpm *

SPECIAL SOLUTION

Effective outside diameter can be reduced to 4.5mm through the use of M2x1.5mm screws.

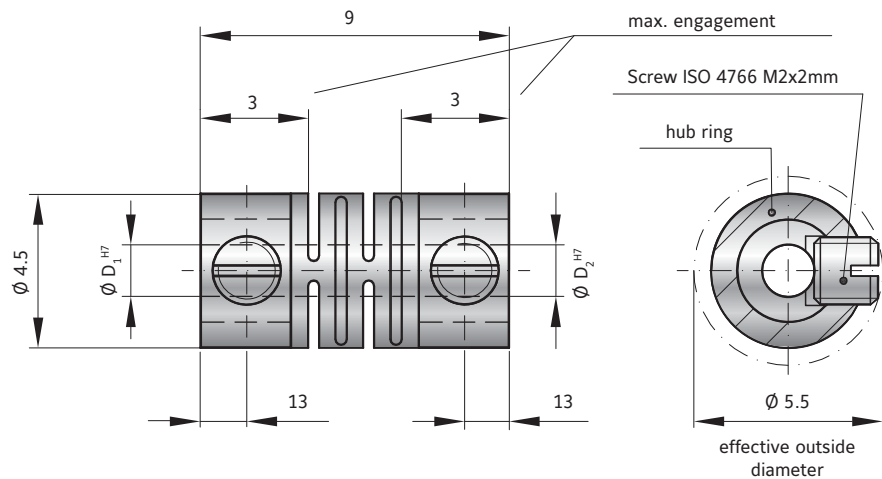

MINIATURE COUPLINGS MK

MODEL FK1/001/9

SIZE			
Rated torque	(Ncm)	T_{KN}	1
Standard bore H7	(mm)	D_1, D_2	1.5 / 1.5 or 2 / 1.5 additional bore diameters available upon request
Moment of inertia	(gcm ²)	$J_{ges.}$	5.39
Approximate weight	(g)		0.47
Torsional stiffness	(Ncm/rad)	C_T	23 (measured at +20° C)
Axial	(mm)	Max. values	0.2
Lateral	(mm)		0.1
Angular	(degree)		1.5

COUPLING ASSEMBLY AND MOUNTING

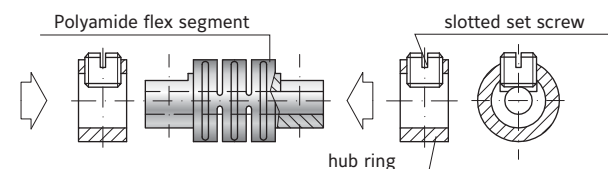

The screw threads through the clamping ring, through a slot in the flexible segment, and down onto the shaft, securing the entire assembly. Including a flat on the shaft can improve torque transmission.

Caution: Always use a precisely calibrated torque wrench during installation.

ORDERING EXAMPLE	FK1	001	9	1.5	1.5	XX
Model	●					Special designation only (e.g. special screw size).
Size		●				
Overall length mm			●			
Bore D1 H7				●		
Bore D2 H7					●	
For custom features place an XX at the end of the part number and describe the special requirements (e.g. FK1/001/9/1.5/1.5/XX; XX=M2x1.5mm screws)						

DISMOUNTING

For dismounting, simply loosen the set screws and remove the coupling from the shafts.

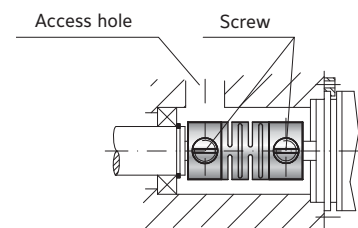





SIZES FROM 0.5 - 25,000 Nm BACKLASH FREE ELASTOMER INSERT COUPLINGS

GENERAL INFORMATION ABOUT R+W ELASTOMER COUPLINGS:



SERVICE LIFE

When properly selected, handled, and installed, these couplings are maintenance free with infinite service life.

ATEX (Optional)

For use in hazardous zones 1/21 and 2/22, the elastomer coupling has been authorized under directive 94/9/EG and is available with certification.

SPECIAL SOLUTIONS

Various materials, tolerances, dimensions and performance ratings available for custom applications on request.

FIT CLEARANCE

Overall shaft / hub clearance of 0.01 - 0.05 mm

EK**TX**

BACKLASH FREE ELASTOMER COUPLINGS

SERVOMAX® AND ECOLIGHT®

SIZES FROM 0.5 - 25,000 Nm

MODEL

FEATURES

EKL

**with clamping hub
from 0.5 - 2,150 Nm**

- ▶ compact design
- ▶ low moment of inertia
- ▶ easy mounting

Page 68

EK2

**with clamping hub
from 6 - 2,150 Nm**

- ▶ high concentricity
- ▶ backlash free
- ▶ easy mounting

Page 69

EKH

**with fully split clamping hub
from 4 - 25,000 Nm**

- ▶ for lateral installation
- ▶ allows for pre-aligned shafts
- ▶ easy mounting

Pages 70-71

EK6

**with conical clamping ring
from 4 - 25,000 Nm**

- ▶ high concentricity
- ▶ high clamping pressure
- ▶ self centering hub design
- ▶ allows for axial installation

Pages 72-73

MODEL

FEATURES

EK1



**with keyway mounting
from 0.5 - 25,000 Nm**

Pages 74-75

- ▶ press fit design
- ▶ readily modified for custom dimensions

TX1



**with keyway mounting
from 0.5 - 810 Nm**

Pages 76-77

- ▶ corrosion proof
- ▶ low cost
- ▶ light weight

EK7



**with expanding shaft
from 2 - 2,150 Nm**

Page 78

- ▶ for hollow shaft mounting
- ▶ expanding shaft through axial tightening
- ▶ short body length after installation

EKZ



**intermediate spacer
from 2 - 2,150 Nm**

Page 79

- ▶ high lateral misalignment
- ▶ easy to mount
- ▶ vibration damping

GENERAL INFORMATION

R+W ELASTOMER COUPLINGS

AXES OF MISALIGNMENT

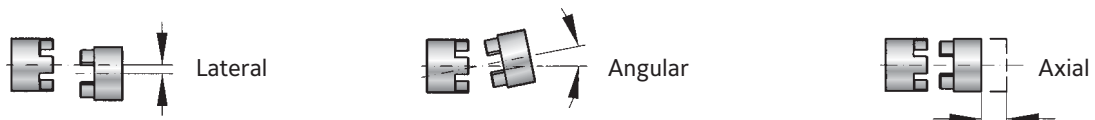

FUNCTION

The equalizing element of the EK coupling is the elastomer insert. It transmits torque without backlash or vibration. The elastomer insert defines the characteristics of the entire drive system.

Backlash is eliminated by the press fit of the elastomer into the hubs. Through variation of the Shore hardness of the elastomer insert, the coupling system can be optimized for the ideal torsional characteristics.

SIZES 2 - 800



Shore hardness 98 A

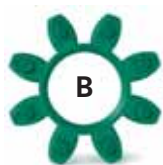

Shore hardness 64 Sh D



Shore hardness 80 Sh A



Shore hardness 65 Sh D



Shore hardness 64 Sh D

SIZES 2500 - 9500

THE COUPLING INCLUDES 5X ELASTOMER SEGMENTS

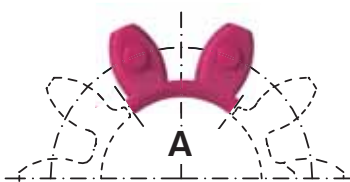

Shore hardness 98 A

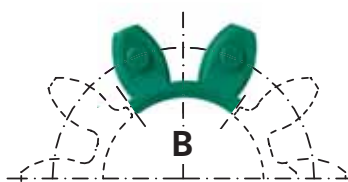

Shore hardness 64 Sh D

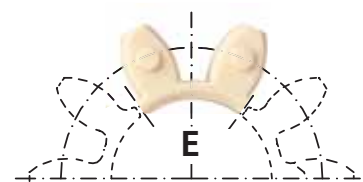

Shore hardness 64 Sh D

DESCRIPTION OF THE ELASTOMER TYPES

Type	Shore hardness	Color	Material	Relative damping (μ)	Temperature range	Features
A	98 Sh A	red	TPU	0.4 - 0.5	-30°C to +100°C	high damping
B	64 Sh D	green	TPU	0.3 - 0.45	-30°C to +120°C	high torsional stiffness
C	80 Sh A	yellow	TPU	0.3 - 0.4	-30°C to +100°C	very high damping
D*	65 Sh D	black	TPU	0.3 - 0.45	-10°C to + 70°C	electrically conductive
E	64 Sh D	beige	Hytrell	0.3 - 0.45	-50°C to +150°C	temperature resistant

* The electrical conductivity of the elastomer material is to prevent the electrostatic charging of the elastomer coupling system, to reduce the risk of sparking in operation. ATEX technical data is available upon request.

The values of the relative damping were determined at 10 Hz and +20° C.

SIZES EK

SIZE		2			5			10			20			60			150		
Type (Elastomer insert)		A	B	C	A	B	C	A	B	C	A	B	C	A	B	C	A	B	C
Static torsional stiffness (Nm/rad)	C_T	50	115	17	150	350	53	260	600	90	1140	2500	520	3290	9750	1400	4970	10600	2000
Dynamic torsional stiffness (Nm/rad)	C_{Tdyn}	100	230	35	300	700	106	541	1650	224	2540	4440	876	7940	11900	2072	13400	29300	3590
Lateral (mm)	Max. values	0.08	0.06	0.2	0.08	0.06	0.2	0.1	0.08	0.22	0.1	0.08	0.25	0.12	0.1	0.25	0.15	0.12	0.3
Angular (Degree)		1	0.8	1.2	1	0.8	1.2	1	0.8	1.2	1	0.8	1.2	1	0.8	1.2	1	0.8	1.2
Axial (mm)		±1			±1			±1			±2			±2			±2		

SIZE		300			450			800			2500		4500		9500	
Type (Elastomer insert)		A	B	C	A	B	C	A	B	C	A	B	A	B	A	B
Static torsional stiffness (Nm/rad)	C_T	12400	18000	3000	15100	27000	4120	41300	66080	10320	87600	109000	167000	372000	590000	670000
Dynamic torsional stiffness (Nm/rad)	C_{Tdyn}	23700	40400	6090	55400	81200	11600	82600	180150	28600	175000	216000	337000	743000	1180000	1340000
Lateral (mm)	Max. values	0.18	0.14	0.35	0.2	0.18	0.35	0.25	0.2	0.4	0.5	0.3	0.5	0.3	0.6	0.4
Angular (Degree)		1	0.8	1.2	1	0.8	1.2	1	0.8	1.2	1.5	1	1.5	1	1.5	1
Axial (mm)		±2			±2			±2			±3		±4		±5	

Static torsional stiffness at 50% T_{KN}

Dynamic torsional stiffness at T_{KN}

COMPACT VERSION WITH CLAMPING HUB

0.5 - 2,150 Nm



ABOUT

FEATURES

- ▶ short overall length
- ▶ easy mounting
- ▶ vibration damping

MATERIAL

- ▶ **Hubs:** up to size 450 high strength aluminum; size 800 steel
- ▶ **Elastomer:** wear resistant thermally stable TPU

DESIGN

Two concentrically machined hubs with curved jaws and clamping screws. Elastomer is press fit for zero backlash; standard versions are electrically isolating.

ORDERING EXAMPLE
see page 71

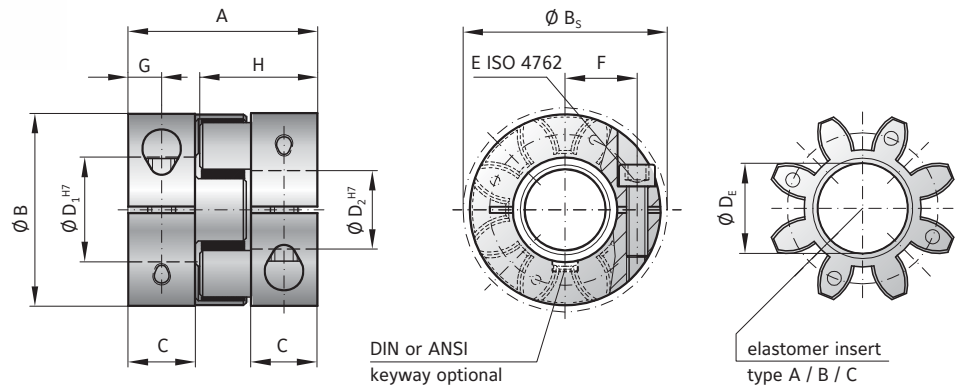

MODEL EKL

SIZE	2			5			10			20			60			150			300			450			800			
Type (Elastomer insert)	A	B	C	A	B	C	A	B	C	A	B	C	A	B	C	A	B	C	A	B	C	A	B	C	A	B	C	
Rated torque (Nm) T_{KN}	2	2.4	0.5	9	12	2	12.5	16	4	17	21	6	60	75	20	160	200	42	325	405	84	530	660	95	950	1100	240	
Max. torque* (Nm) T_{Kmax}	4	4.8	1	18	24	4	25	32	6	34	42	12	120	150	35	320	400	85	650	810	170	1060	1350	190	1900	2150	400	
Overall length (mm)	A	20		26			32			50			58			62			86			94			123			
Outside diameter (mm)	B	16		25			32			42			56			66.5			82			102			136.5			
Outside diameter with screw head (mm)	B_s	17		25			32			44.5			57			68			85			105			139			
Mounting length (mm)	C	6		8			10.3			17			20			21			31			34			46			
Inside diameter range H7 (mm)	$D_{1/2}$	3 - 8		4 - 12.7			4 - 16			8 - 25			12 - 32			19 - 36			20 - 45			28 - 60			35 - 80			
Inside diameter of elastomer (mm)	D_e	6.2		10.2			14.2			19.2			26.2			29.2			36.2			46.2			60.5			
Clamping screw (ISO 4762)	E	M2		M3			M4			M5			M6			M8			M10			M12			M16			
Tightening torque of the clamping screw (Nm)	E	0.6		2			4			8			15			35			70			120			290			
Distance between centers (mm)	F	5.5		8			10.5			15.5			21			24			29			38			50.5			
Distance (mm)	G	3		4			5			8.5			10			11			15			17.5			23			
Hub length (mm)	H	12		16.7			20.7			31			36			39			52			57			74			
Moment of inertia per hub (10^{-3} kgm^2) J_1/J_2	J_1/J_2	0.0003		0.002			0.003			0.01			0.04			0.08			0.3			0.66			8			
Approx. weight (kg)		0.008		0.02			0.05			0.12			0.3			0.5			0.9			1.5			8.5			
Speed standard (min^{-1})		15,000		15,000			13,000			12,500			11,000			10,000			9,000			8,000			4,000			
Speed balanced (10^3 min^{-1})		60	67	45	57	65	43	53	63	40	45	60	35	31	31	25	22	26	18	22	26	16	16	17	12	13	13	8

For information on shaft misalignment, torsional stiffness, and other details about the elastomer inserts see pages 66 + 67.

* Maximum transmittable torque of the clamping hub depends on the bore diameter

Size	Ø 3	Ø 4	Ø 5	Ø 8	Ø 16	Ø 19	Ø 25	Ø 30	Ø 32	Ø 35	Ø 45	Ø 50	Ø 55	Ø 60	Ø 65	Ø 70	Ø 75	Ø 80
2	0.2	0.8	1.5	2.5														
5		1.5	2	8														
10			4	12	32													
20				20	35	45	60											
60					50	80	100	110	120									
150						120	160	180	200	220								
300						200	230	300	350	380	420							
450								420	480	510	600	660	750	850				
800										700	750	800	835	865	900	925	950	1,000

Higher torque possible with keyways.

STANDARD VERSION WITH CLAMPING HUB

6 - 2,150 Nm

ABOUT



FEATURES

- ▶ easy mounting
- ▶ highly concentric assembly
- ▶ vibration damping

MATERIAL

- ▶ **Hubs:** up to size 450 high strength aluminum; size 800 steel
- ▶ **Elastomer:** wear resistant thermally stable TPU

DESIGN

Two concentrically machined hubs with curved jaws and clamping screws. Elastomer is press fit for zero backlash; standard versions are electrically isolating.

ORDERING EXAMPLE
see page 71

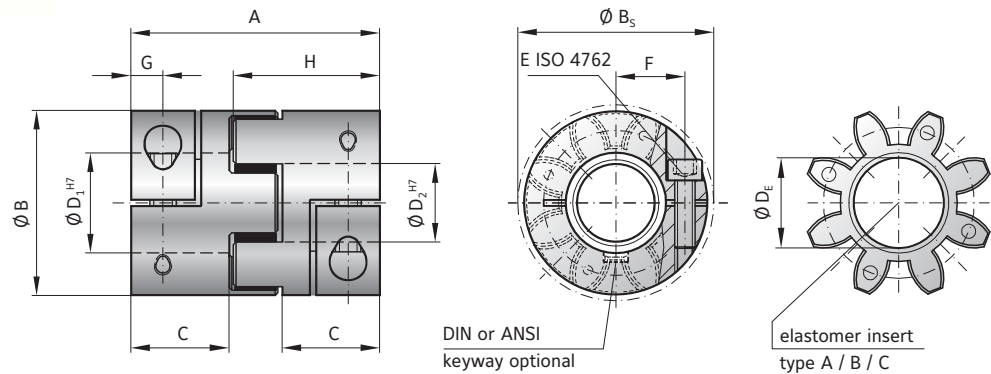

MODEL EK2

SIZE	20			60			150			300			450			800		
Type (Elastomer insert)	A	B	C	A	B	C	A	B	C	A	B	C	A	B	C	A	B	C
Rated torque (Nm) T_{KN}	17	21	6	60	75	20	160	200	42	325	405	84	530	660	95	950	1100	240
Max. torque* (Nm) T_{Kmax}	34	42	12	120	150	35	320	400	85	650	810	170	1060	1350	190	1900	2150	400
Overall length (mm) A	66			78			90			114			126			162		
Outside diameter (mm) B	42			56			66.5			82			102			136.5		
Outside diameter with screw head (mm) B_s	44.5			57			68			85			105			139		
Mounting length (mm) C	25			30			35			45			50			65		
Inside diameter range H7 (mm) $D_{1/2}$	8 - 25			12 - 32			19 - 36			20 - 45			28 - 60			35 - 80		
Inside diameter of elastomer (mm) D_e	19.2			26.2			29.2			36.2			46.2			60.5		
Clamping screw (ISO 4762) E	M5			M6			M8			M10			M12			M16		
Tightening torque of the clamping screw (Nm)	8			15			35			70			120			290		
Distance between centers (mm) F	15.5			21			24			29			38			50.5		
Distance (mm) G	8.5			10			12			15			17.5			23		
Hub length (mm) H	39			46			52.5			66			73			93.5		
Moment of inertia per hub (10^{-3} kgm^2) J_1/J_2	0.016			0.05			0.13			0.4			0.9			9.5		
Approx. weight (kg)	0.15			0.35			0.6			1.1			1.7			10		
Speed standard (min^{-1})	12,500			11,000			10,000			9,000			8,000			4,000		
Speed balanced (10^3 min^{-1})	45	60	35	31	31	25	22	26	18	22	26	16	16	17	12	13	13	8

For information on shaft misalignment, torsional stiffness, and other details about the elastomer inserts see pages 66 + 67.

* Maximum transmittable torque of the clamping hub depends on the bore diameter

Size	Ø 8	Ø 16	Ø 19	Ø 25	Ø 30	Ø 32	Ø 35	Ø 45	Ø 50	Ø 55	Ø 60	Ø 65	Ø 70	Ø 75	Ø 80
20	20	35	45	60											
60		50	80	100	110	120									
150			120	160	180	200	220								
300			200	230	300	350	380	420							
450				420	480	510	600	660	750	850					
800					700	750	800	835	865	900	925	950	1,000		

Higher torque possible with keyways

WITH FULLY SPLIT CLAMPING HUB 4 - 2,150 Nm



ABOUT

FEATURES

- ▶ lateral mounting
- ▶ easy installation and removal
- ▶ allows for pre-alignment of shafts

MATERIAL

- ▶ **Hubs:** up to size 450 high strength aluminum; size 800 steel
- ▶ **Elastomer:** wear resistant thermally stable TPU

DESIGN

Two concentrically machined, fully split hubs with curved jaws and clamping screws. Elastomer is press fit for zero backlash; standard versions are electrically isolating.

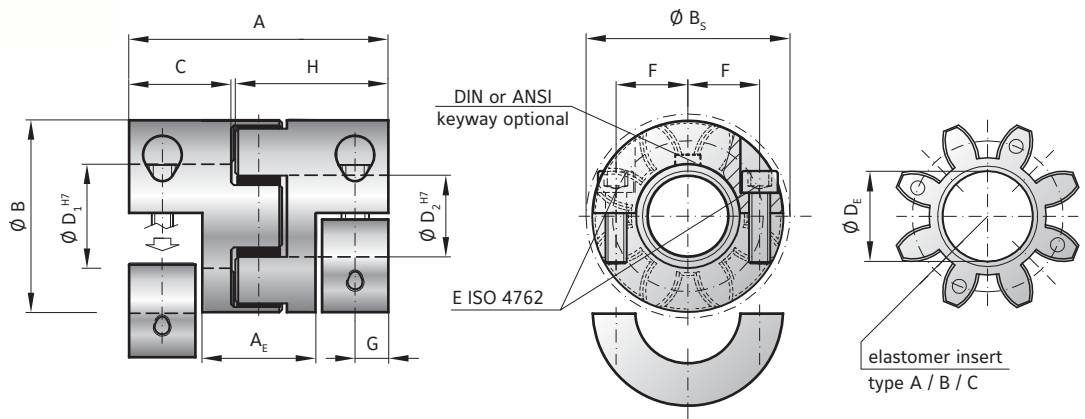

MODEL EKH

SIZE	10			20			60			150			300			450			800		
Type (Elastomer insert)	A	B	C	A	B	C	A	B	C	A	B	C	A	B	C	A	B	C	A	B	C
Rated torque (Nm) T_{KN}	12.6	16	4	17	21	6	60	75	20	160	200	42	325	405	84	530	660	95	950	1100	240
Max. torque* (Nm) T_{Kmax}	25	32	6	34	42	12	120	150	35	320	400	85	650	810	170	1060	1350	190	1900	2150	400
Overall length (mm)	A			66			78			90			114			126			162		
Length of center section (mm)	A_E			28			33			37			49			51			65		
Outside diameter (mm)	B			42			56			66.5			82			102			136.5		
Outside diameter with screw head (mm)	B_s			44.5			57			68			85			105			139		
Mounting length (mm)	C			25			30			35			45			50			65		
Inside diameter range H7 (mm)	$D_{1/2}$			8 - 25			12 - 32			19 - 36			20 - 45			28 - 60			35 - 80		
Inside diameter of elastomer (mm)	D_E			19.2			26.2			29.2			36.2			46.2			60.5		
Clamping screw (ISO 4762)	E			4 x M5			4 x M6			4 x M8			4 x M10			4 x M12			4 x M16		
Tightening torque of the clamping screw (Nm)	E			8			15			35			70			120			290		
Distance between centers (mm)	F			15.5			21			24			29			38			50.5		
Distance (mm)	G/G_1			8.5			10			12			15			17.5			23		
Hub length (mm)	H/H_1			39			46			52.5			66			73			93.5		
Moment of inertia per hub (10^{-3} kgm^2)	J_1/J_2			0.02			0.06			0.1			0.4			1			9.5		
Approx. weight (kg)				0.15			0.35			0.6			1.1			1.7			10		
Speed standard (min^{-1})				12,500			11,000			10,000			9,000			8,000			4,000		
Speed balanced (10^3 min^{-1})	53	63	40	45	60	35	31	31	25	22	26	18	22	26	16	16	17	12	13	13	8

For information on shaft misalignment, torsional stiffness, and other details about the elastomer inserts see pages 66 + 67.

* Maximum transmittable torque of the clamping hub depends on the bore diameter

Size	Ø 6	Ø 8	Ø 16	Ø 19	Ø 25	Ø 30	Ø 32	Ø 35	Ø 45	Ø 50	Ø 55	Ø 60	Ø 65	Ø 70	Ø 75	Ø 80	Ø 90	Ø 120	Ø 140
10	6	12	32																
20		30	40	50	65														
60			65	120	150	180	200												
150				180	240	270	300	330											
300				300	340	450	520	570	630										
450						630	720	770	900	1120	1180	1350							
800								1050	1125	1200	1300	1400	1450	1500	1550	1600			
2500								1400	1800	2000	2250	2500	2700	2900	3100	3300	3700		
4500								2400	2600	2900	3100	3400	3600	3900	4100	4700	6200		
9500									5000	5500	6000	6500	7000	7500	8000	9000	12000	14000	

Higher torque possible with keyways



ABOUT

FEATURES

- ▶ lateral mounting
- ▶ easy installation and removal
- ▶ allows for pre-alignment of shafts

MATERIAL

- ▶ **Hubs:** GGG 40
- ▶ **Elastomer:** wear resistant thermally stable TPU

DESIGN

Two concentrically machined, fully split hubs with curved jaws and clamping screws. 5x elastomer segments press fit for zero backlash; standard versions are electrically isolating.

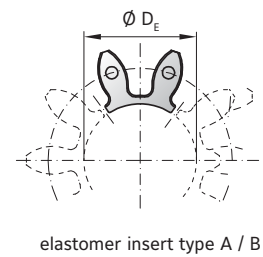
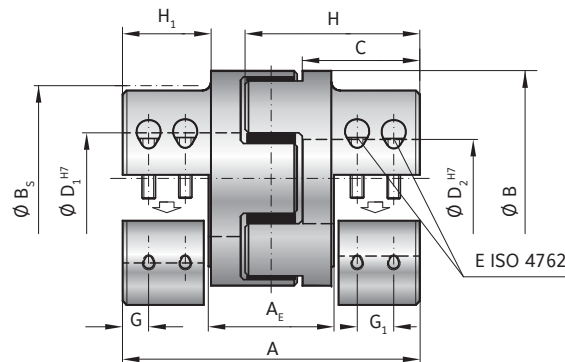

MODEL EKH

SIZE	2500		4500		9500		
	A	B	A	B	A	B	
Type (Elastomer insert)							
Rated torque (Nm)	T_{KN} 1950	2450	5000	6200	10000	12500	
Max. torque* (Nm)	T_{Kmax} 3900	4900	10000	12400	20000	25000	
Overall length (mm)	A	213	272		341		
Length of center section (mm)	A_E	78	104		131		
Outside diameter (mm)	B	160	225		290		
Outside diameter with screw head (mm)	B_s	156	190		243		
Mounting length (mm)	C	85	110		140		
Inside diameter range H7 (mm)	$D_{1/2}$	35 - 90	40 - 120		50 - 140		
Inside diameter of elastomer (mm)	D_E	80	111		145		
Clamping screw (ISO 4762)		8 x M16	8 x M20		8 x M24		
Tightening torque of the clamping screw (Nm)	E	300	600		1100		
Distance between centers (mm)	F	57	72.5		90		
Distance (mm)	G/ G_1	36	24 / 34		30 / 48		
Hub length (mm)	H/ H_1	120 / 69	154 / 80		193 / 110		
Moment of inertia per hub (10^{-3} kgm ²)	J_1/J_2	40	147		480		
Approx. weight (kg)		12.5	25		53		
Speed standard (min^{-1})		3,000	3,500		2,000		
Speed balanced (10^3min^{-1})		10	10	8	8	6.5	6.5

For information on shaft misalignment, torsional stiffness, and other details about the elastomer inserts see pages 66 + 67.

* Maximum transmittable torque of the clamping hub depends on the bore diameter see page 70.

ORDERING EXAMPLE	EKL	EK2	EKH	60	A	12.7	24	XX
Model		●						
Size			●					
Elastomer insert type				●				Special designation only (e.g. special bore tolerance).
Bore D1 H7					●			
Bore D2 H7							●	
For custom features place an XX at the end of the part number and describe the special requirements (e.g. EKH/60/A/12.7/24/XX; XX=anodized aluminum)								

EK6

WITH CONICAL CLAMPING RING

4 - 2,150 Nm



ABOUT

FEATURES

- ▶ high clamping pressure
- ▶ self centering on shaft
- ▶ very high concentricity

MATERIAL

- ▶ **Hubs:** up to size 450 high strength aluminum; size 800 steel
- ▶ **Elastomer:** wear resistant thermally stable TPU

DESIGN

Two concentrically machined hubs with curved jaws and conical clamping rings. Elastomer segments press fit for zero backlash; standard versions are electrically isolating.

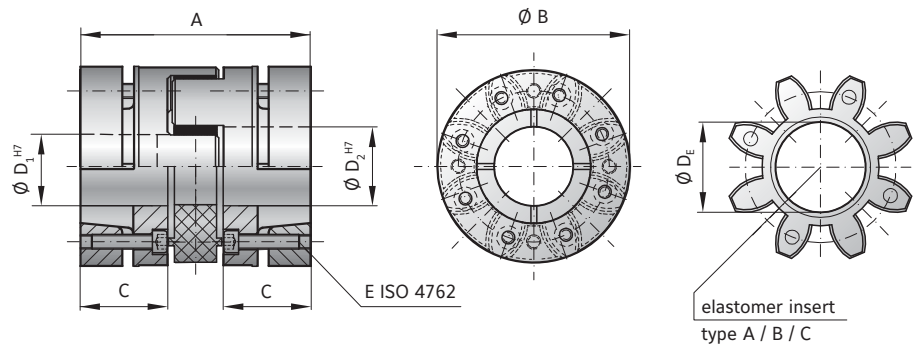

MODEL EK6

SIZE		10			20			60			150			300			450			800		
Type (Elastomer insert)		A	B	C	A	B	C	A	B	C	A	B	C	A	B	C	A	B	C	A	B	C
Rated torque (Nm)	T_{KN}	12.5	16	4	17	21	6	60	75	20	160	200	42	325	405	84	530	660	95	950	1100	240
Max. torque (Nm)	T_{Kmax}	25	32	6	34	42	12	120	150	35	320	400	85	650	810	170	1060	1350	190	1900	2150	400
Overall length (mm)	A	42			56			64			76			96			110			138		
Outside diameter (mm)	B/B ₁	32			43			56			66			82			102			136.5		
Mounting length (mm)	C	15			20			23			28			36			42			53		
Inside diameter range H7 (mm)	$D_{1/2}$	6 - 16			8 - 24			12 - 32			19 - 35			20 - 45			28 - 55			32 - 80		
Inside diameter of elastomer (mm)	D_e	14.2			19.2			26.2			29.2			36.2			46.2			60.5		
Clamping screw (ISO 4762)		3x M3			6x M4			4x M5			8x M5			8x M6			8x M8			8x M10		
Tightening torque of the clamping screw (Nm)	E	2			3			6			7			12			35			55		
Distance (mm)	F																					
Moment of inertia per hub (10^{-3} kgm ²)	J_1/J_2	0.004			0.015			0.05			0.1			0.3			0.85			9.2		
Approx. weight (kg)		0.08			0.12			0.3			0.5			0.9			1.5			9.6		
Speed standard (min ⁻¹)		20,000			19,000			14,000			13,000			10,000			9,000			4,000		
Speed balanced (10^3 min ⁻¹)		53	63	40	45	60	35	31	31	25	22	26	18	22	26	16	16	17	12	13	13	8

For information on shaft misalignment, torsional stiffness, and other details about the elastomer inserts see pages 66 + 67.

ORDERING EXAMPLE	EK6	60	A	19	22.23	XX
Model	●					Special designation only (e.g. special bore tolerance).
Size		●				
Elastomer insert type			●			
Bore D1 H7				●		
Bore D2 H7					●	

For custom features place an XX at the end of the part number and describe the special requirements (e.g. EK6/60/A/19/22.23/XX; XX=finely balanced ISO G2.5 / 30,000 rpm)

EK6

WITH CONICAL CLAMPING RING

1,950 - 25,000 Nm

ABOUT

FEATURES

- ▶ high clamping pressure
- ▶ self centering on shaft
- ▶ very high concentricity

MATERIAL

- ▶ **Hubs:** GGG40
- ▶ **Elastomer:** wear resistant thermally stable TPU

DESIGN

Two concentrically machined hubs with curved jaws and conical clamping rings. 5x elastomer segments press fit for zero backlash; standard versions are electrically isolating.

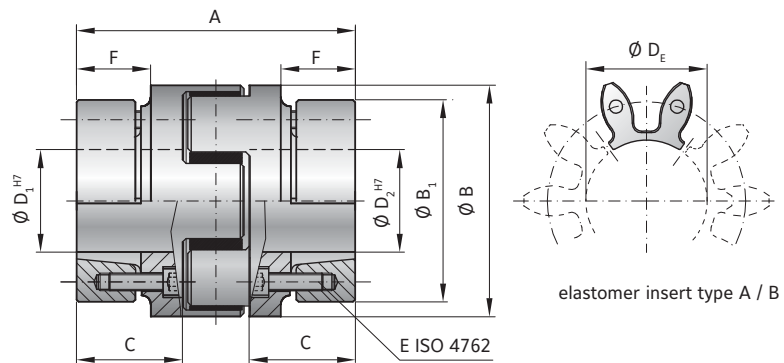

MODEL EK6

SIZE		2500		4500		9500	
Type (Elastomer insert)		A	B	A	B	A	B
Rated torque (Nm)	T_{KN}	1950	2450	5000	6200	10000	12500
Max. torque (Nm)	T_{Kmax}	3900	4900	10000	12400	20000	25000
Overall length (mm)	A	177		227		282	
Outside diameter (mm)	B/B ₁	160 / 159		225 / 208		285	
Mounting length (mm)	C	70		90		112	
Inside diameter range H7 (mm)	D _{1/2}	40 - 95		50 - 130		60 - 170	
Inside diameter of elastomer (mm)	D _E	80		111		145	
Clamping screw (ISO 4762)		10x M10		10x M12		10x M16	
Tightening torque of the clamping screw (Nm)	E	60		100		160	
Distance (mm)	F	51		66		80	
Moment of inertia per hub (10 ⁻³ kgm ²)	J ₁ /J ₂	31.7		135.7		469.2	
Approx. weight (kg)		15		35		73	
Speed standard (min ⁻¹)		3,500		3,000		2,000	
Speed balanced (10 ³ min ⁻¹)		10	10	8	8	6.5	6.5

For information on shaft misalignment, torsional stiffness, and other details about the elastomer inserts see pages 66 + 67.

ORDERING EXAMPLE	EK6	2500	A	50.8	80	XX
Model	●					Special designation only (e.g. special bore tolerance).
Size		●				
Elastomer insert type			●			
Bore D1 H7				●		
Bore D2 H7					●	

For custom features place an XX at the end of the part number and describe the special requirements (e.g. EK6/2500/A/50.8/80/XX; XX=stainless steel)

EK1

WITH KEYWAY MOUNTING

0.5 - 2,150 Nm



ABOUT

FEATURES

- ▶ press fit design
- ▶ readily modified for custom dimensions
- ▶ low backlash (keyway)

MATERIAL

- ▶ **Hubs:** up to size 450 high strength aluminum; size 800 steel
- ▶ **Elastomer:** wear resistant thermally stable TPU

DESIGN

Two concentrically machined hubs with curved jaws, keyways, and set screws. Elastomer is press fit for zero backlash; standard versions are electrically isolating.

Optional:

Conical bores for Fanuc motors and other tapered shafts available.

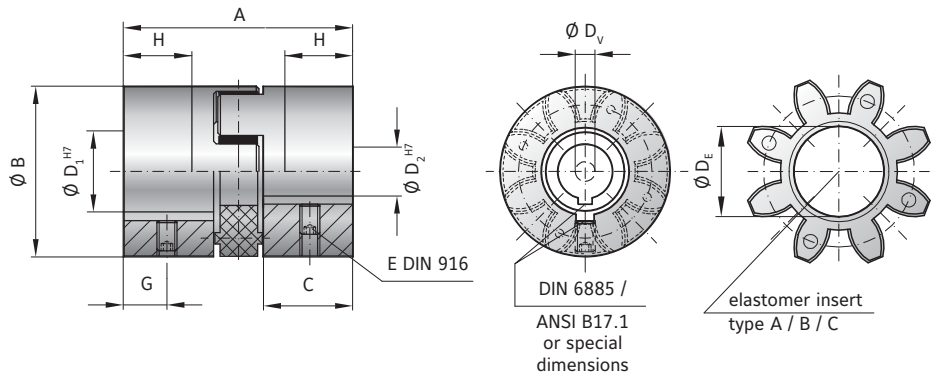

MODEL EK1

SIZE	2			5			10			20			60			150			300			450			800					
Type (Elastomer insert)	A	B	C	A	B	C	A	B	C	A	B	C	A	B	C	A	B	C	A	B	C	A	B	C	A	B	C	A	B	C
Rated torque (Nm) T_{KN}	2	2.4	0.5	9	12	2	12.5	16	4	17	21	6	60	75	20	160	200	42	325	405	84	530	660	95	950	1100	240			
Max. torque (Nm) T_{Kmax}	4	4.8	1	18	24	4	25	32	6	34	42	12	120	150	35	320	400	85	650	810	170	1060	1350	190	1900	2150	400			
Overall length (mm)	A			34			35			66			78			90			114			126			162					
Outside diameter (mm)	B/B ₂			25			32			42			56			66.5			82			102			136.5					
Mounting length (mm)	C			12			12			25			30			35			45			50			65					
Inside diameter (pilot bored) (mm)	D _v			4			6			7			9			14			18			22			29					
Inside diameter range H7 (mm)	D _{1/2}			6 - 15			6 - 18			8 - 25			12 - 32			19 - 38			20 - 45			28 - 60			32 - 80					
Inside diameter of elastomer (mm)	D _e			10.2			14.2			19.2			26.2			29.2			36.2			46.2			60.5					
Set screws (DIN 916)	E																													
Distance (mm)	G			5			6			9			11			12			15			17			30					
Possible shortening length (mm)	H			6			6			19			22			26			32			37			43					
Moment of inertia per hub (10 ⁻³ kgm ²) $J_{1/2}$	0.0001			0.001			0.003			0.02			0.06			0.1			0.4			1.1			12					
Approx. weight (kg)	0.008			0.03			0.08			0.15			0.35			0.6			1.1			1.7			11					
Speed standard (min ⁻¹)	15,000			15,000			13,000			12,500			11,000			10,000			9,000			8,000			4,000					
Speed balanced (10 ³ min ⁻¹)	60	67	45	57	65	43	53	63	40	45	60	35	31	31	25	22	26	18	22	26	16	16	17	12	13	13	8			

For information on shaft misalignment, torsional stiffness, and other details about the elastomer inserts see pages 66 + 67.

** set screw size

D ₁ /D ₂	E
- Ø 10	M3
Ø 10.1 - 12	M4
Ø 12.1 - 30	M5
Ø 30.1 - 58	M8
Ø 58.1 - 95	M10
Ø 95.1 - 130	M12
Ø 130.1 - 170	M16

NOTES ON MACHINING FEATURES INTO PILOT BORED (DV) COUPLING

Pilot bored coupling hubs (bore = DV) are available to be custom machined by the customer. They come with a small diameter bore and no set screw.

For precision applications a concentricity tolerance of 0.03 is recommended for smooth running. The hub can be shortened by a length value of up to dimension H.

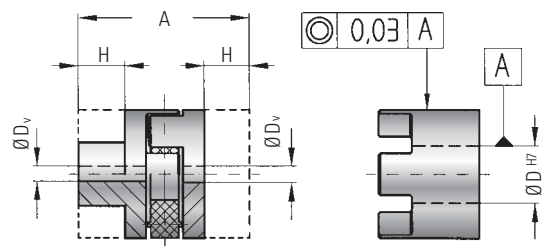

Bores <6mm made without keyway.

EK1

WITH KEYWAY MOUNTING

1,950 - 25,000 Nm

ABOUT

FEATURES

- ▶ press fit design
- ▶ readily modified for custom dimensions
- ▶ low backlash (keyway)

MATERIAL

- ▶ **Hubs:** GGG40
- ▶ **Elastomer:** wear resistant thermally stable TPU

DESIGN

Two concentrically machined hubs with curved jaws, keyways, and set screws. 5x elastomer segments press fit for zero backlash; standard versions are electrically isolating.

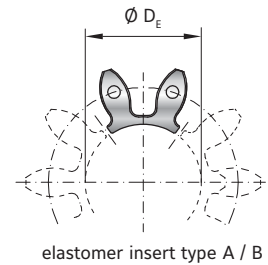
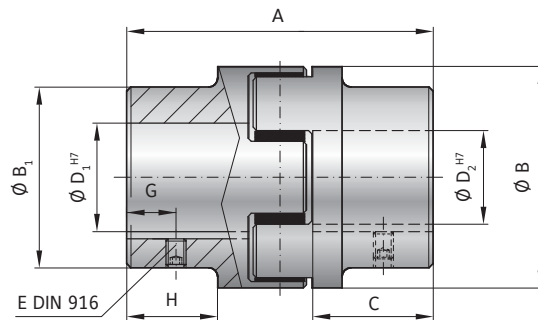

MODEL EK1

SIZE		2500		4500		9500	
Type (Elastomer insert)		A	B	A	B	A	B
Rated torque (Nm)	T_{KN}	1950	2450	5000	6200	10000	12500
Max. torque (Nm)	T_{Kmax}	3900	4900	10000	12400	20000	25000
Overall length (mm)	A	213		272		341	
Outside diameter (mm)	B/B ₁	160 / 154		225 / 190		290 / 240	
Mounting length (mm)	C	88		113		142	
Inside diameter (pilot bored) (mm)	D _v	30		40		50	
Inside diameter range H7 (mm)	D _{1/2}	30 - 95		40 - 130		50 - 170	
Inside diameter of elastomer (mm)	D _e	80		111		145	
Set screws (DIN 916)	E	see table (depending on bore ϕ)**					
Distance (mm)	G	25		30		40	
Possible shortening length (mm)	H	69		89		110	
Moment of inertia per hub (10^{-3} kgm^2)	J ₁ /J ₂	40		147		480	
Approx. weight (kg)		12.5		25		53	
Speed standard (min^{-1})		3,500		3,000		2,000	
Speed balanced (10^3 min^{-1})		10	10	8	8	6.5	6.5

For information on shaft misalignment, torsional stiffness, and other details about the elastomer inserts see pages 66 + 67.

ORDERING EXAMPLE	EK1	2500	A	50.8	80	XX
Model	●					
Size		●				
Elastomer insert type			●			
Bore D1 H7				●		
Bore D2 H7					●	
For custom features place an XX at the end of the part number and describe the special requirements (e.g. EK1/2500/A/50.8/80/XX; XX=stainless steel)						

Special designation only (e.g. special bore tolerance).

TX1

WITH KEYWAY MOUNTING

0.5 - 810 Nm



ABOUT

FEATURES

- ▶ very low mass and moment of inertia
- ▶ corrosion proof
- ▶ economically priced

MATERIAL

- ▶ **Hubs:** extremely rigid, glass fiber reinforced thermoplastic
- ▶ **Elastomer:** wear resistant thermally stable TPU

DESIGN

Two highly concentric, precision molded hubs with curved jaws, keyways, and set screws, suitable for use in temperatures ranging from -20 to +100°C. Elastomer is press fit for zero backlash. Coupling system is electrically isolating.

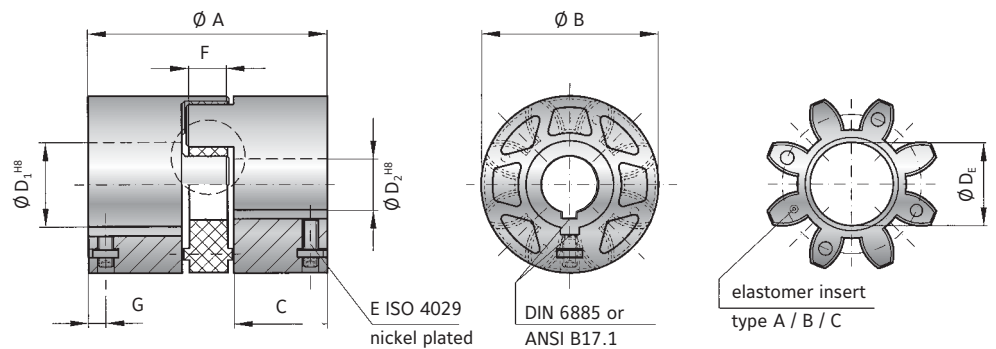

MODEL TX1

SIZE		2			10			20			60			150			300		
Elastomer insert		A	B	C	A	B	C	A	B	C	A	B	C	A	B	C	A	B	C
Rated torque	(Nm) T_{KN}	2	2.4	0.5	12.5	16	4	17	21	6	60	75	20	160	200	42	325	405	84
Max. torque	(Nm) T_{Kmax}	4	4.8	1	25	32	6	34	42	12	120	150	35	320	400	85	650	810	170
Overall length	(mm) A	20			35			66			78			90			114		
Outside diameter	(mm) B	17			32			42			56			66.5			82		
Mounting length	(mm) C	6.5			12			25			30			35			45		
Inside diameter possible from - to H8	(mm) $D_{1/2}$	3 - 8			6 - 16			10 - 24			16 - 30			19 - 38			20 - 45		
Inside diameter of elastomer	(mm) D_E	6.2			14.2			19.2			27.2			30.2			38.2		
Set screw (ISO 4029)	(Nm) E	M3			M3			M4			M5			M6			M6		
Tightening torque of the clamping screw max.	(Nm)	0.8			0.8			1.5			3			6			6		
Width elastomer insert	(mm) F	5			9.5			12			14			15			18		
Distance	(mm) G	3			3.5			4			6			7			7		
Moment of inertia per Hub	(kgm ²) J_1/J_2	1.9			1.4			10			30			70			180		
Approx. weight	(g)	5.9			30			80			180			270			510		
Speed	(min ⁻¹)	12,000			10,000			9,000			8,000			7,000			6,000		
Static torsional stiffness(Nm/rad)	C_T	50	115	1.7	260	600	90	1140	2500	520	3290	9750	1400	4970	10600	1130	12400	18000	1280
Dynamic torsional stiffness (Nm/rad)	C_{Tdyn}	100	230	35	541	1650	224	2540	4440	876	7940	11900	1350	13400	29300	3590	23700	40400	6090
Lateral	(mm)	0.08	0.06	0.2	0.2	0.17	0.2	0.2	0.2	0.22	0.22	0.22	0.25	0.25	0.25	0.28	0.28	0.28	0.3
Angular	(Degree)	1			1.5			1.5			1.5			1.5			1.5		
Axial	(mm)	±1			±1			±1.5			±1.5			±2			±2		

Static torsional stiffness at 50% T_{KN}

Dynamic torsional stiffness at T_{KN}

DESCRIPTION OF THE ELASTOMER TYPES IN THE TX SERIES



Type	Shore hardness	Color	Material	Relative damping (ψ)	Temperature range	Features
A	98 Sh A	red	TPU	0.4 - 0.5	-30°C to +100°C	high damping
B	64 Sh D	green	TPU	0.3 - 0.45	-30°C to +100°C	high torsional stiffness
C	80 Sh A	yellow	TPU	0.3 - 0.4	-30°C to +100°C	very high damping

FUNCTION

The equalizing element of the TX coupling is the elastomer insert. It transmits torque without backlash or vibration. The elastomer defines the characteristics of the entire drive system.

Through a special convex tooth geometry in the elastomer ring, greater shaft misalignment can be compensated for. Changing the Shore hardness of the elastomer allows the ECOLIGHT coupling to be optimized for ideal torsional characteristics.

BORE DIAMETER DEPENDS ON HUB STRUCTURE

Size	2	10	20	60	150	300
 Structure I from - to	solid hub no special structure	6 - 12.9	10 - 14.9	16 - 20.9	19 - 26.9	20 - 28.9
 Structure II from - to	solid hub no special structure	13 - 16	15 - 19.9	21 - 25.9	27 - 33.9	29 - 38.9
 Structure III from - to	solid hub no special structure		20 - 24	26 - 30	34 - 38	39 - 45

ORDERING EXAMPLE	TX1	60	A	20	24	XX
Model	●					Special designation only (e.g. special bore / keyway dimensions).
Size		●				
Elastomer insert type			●			
Bore D1 H8				●		
Bore D2 H8					●	

For custom features place an XX at the end of the part number and describe the special requirements (e.g. TX1/60/A/20/24/XX; XX="D" holes per drawing)

EK7

WITH EXPANDING SHAFT

2 - 2,150 Nm

ABOUT

FEATURES

- ▶ for hollow shaft mounting
- ▶ short overall length
- ▶ solution for mismatched bore / shaft diameters

MATERIAL

- ▶ **Hubs:** up to size 450 high strength aluminum; size 800 steel
- ▶ **Expanding shaft hub:** steel

- ▶ **Elastomer:** wear resistant thermally stable TPU

DESIGN

One concentrically machined hub with clamping screw and curved jaws. One concentrically machined hub with expanding shaft system and curved jaws. Elastomer segment press fit for zero backlash; standard versions are electrically isolating.

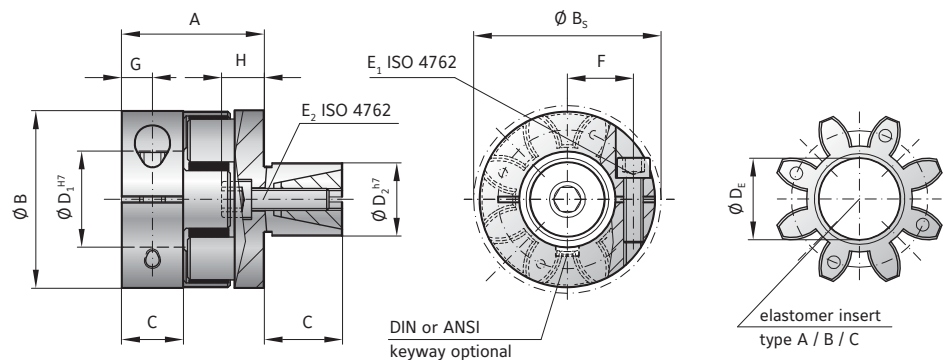

MODEL EK7

SIZE	5			10			20			60			150			300			450			800		
Type (Elastomer insert)	A	B	C	A	B	C	A	B	C	A	B	C	A	B	C	A	B	C	A	B	C	A	B	C
Rated torque (Nm)	9	12	2	12.5	16	4	17	21	6	60	75	20	160	200	42	325	405	84	530	660	95	950	1100	240
Max. torque* (Nm)	18	24	4	25	32	6	34	42	12	120	150	35	320	400	85	650	810	170	1060	1350	190	1900	2150	400
Overall length (mm)	22			28			40			46			51			68			76			94		
Outside diameter (mm)	B			32			42			56			66.5			82			102			136.5		
Outside diameter with screw head (mm)	B _s			32			44.5			57			68			85			105			139		
Mounting length (mm)	C ₁			10.3			17			20			21			31			34			46		
Mounting length (mm)	C ₂			20			25			27			32			45			55			60		
Inside diameter range H7 (mm)	D ₁			5 - 16			8 - 25			12 - 32			19 - 36			20 - 45			28 - 60			35 - 80		
Outside diameter range h7 (mm)	D ₂			13 - 25			14 - 30			23 - 38			26 - 42			38 - 60			42 - 70			42 - 80		
Inside diameter of elastomer (mm)	D _e			14.2			19.2			26.2			29.2			36.2			46.2			60.5		
Clamping screw (ISO 4762)	M3			M4			M5			M6			M8			M10			M12			M16		
Tightening torque (Nm)	E ₁			4			8			15			35			70			120			290		
Clamping screw (ISO 4762)	E ₂			M4			M5			M6			M8			M10			M12			M16		
Tightening torque (Nm)	E ₂			9			12			32			60			110			240			300		
Distance between centers (mm)	F			10.5			15.5			21			24			29			38			50.5		
Distance (mm)	G			5			8.5			10			11			15			17.5			23		
Length (mm)	H			7			10			11			16			20			27			27		
Moment of inertia D ₁ (10 ⁻³ kgm ²)	J ₁			0.003			0.01			0.04			0.08			0.3			0.66			8		
Moment of inertia D ₂ (10 ⁻³ kgm ²)	J ₂			0.01			0.04			0.1			0.2			1			2.6			9		
Approx. weight (kg)	0.04			0.05			0.12			0.3			0.5			0.9			1.5			7.6		
Speed standard (min ⁻¹)	15,000			13,000			12,500			11,000			10,000			9,000			8,000			4,000		
Speed balanced (10 ³ min ⁻¹)	57	65	43	53	63	40	45	60	35	31	31	25	22	26	18	22	26	16	16	17	12	13	13	8

For information on shaft misalignment, torsional stiffness, and other details about the elastomer inserts see pages 66 + 67.

*Maximum transmittable torque of the clamping hub depends on the bore diameter (see EKL on page 68).

ORDERING EXAMPLE	EK7	20	A	24	19.05	XX
Model	●					Special designation only (e.g. special bore tolerance).
Size		●				
Elastomer insert type			●			
Bore D1 H7				●		
Expanding shaft D2 h7					●	

For custom features place an XX at the end of the part number and describe the special requirements (e.g. EK7/20/A/24/19.05/XX; XX=stainless steel)



INTERMEDIATE SPACER

0.5 - 2,150 Nm

ABOUT

FEATURES

- ▶ high lateral misalignment
- ▶ easy to mount
- ▶ combine with any two hub designs

MATERIAL

- ▶ **Hubs:** high strength aluminum
- ▶ **Elastomer:** wear resistant thermally stable TPU

DESIGN

A concentrically machined spacer with curved jaws. 2x elastomer segment press fit for zero backlash; standard versions are electrically isolating.

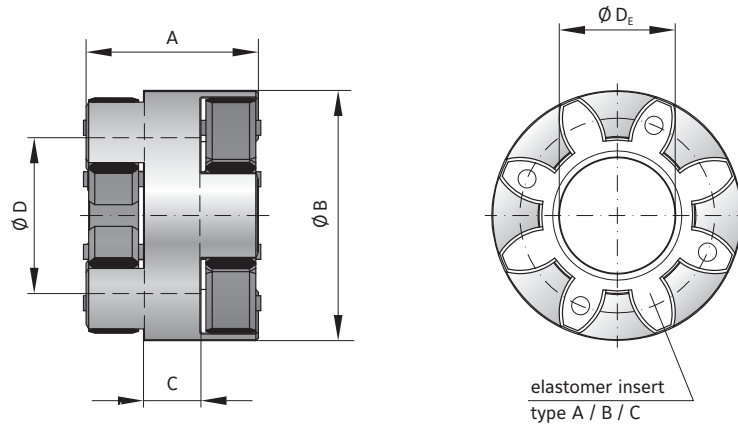

MODEL EKZ

SIZE	2			5			10			20			60			150			300			450			800			
	A	B	C	A	B	C	A	B	C	A	B	C	A	B	C	A	B	C	A	B	C	A	B	C	A	B	C	
Type (Elastomer insert)																												
Rated torque (Nm)	T_{KN}	2	2.4	0.5	9	12	2	12.5	16	4	17	21	6	60	75	20	160	200	42	325	405	84	530	660	95	950	1100	240
Max. torque (Nm)	T_{Kmax}	4	4.8	1	18	24	4	25	32	6	34	42	12	120	150	35	320	400	85	650	810	170	1060	1350	190	1900	2150	400
Overall length (mm)	A	20			26			30			39			48			53			62			86			81		
Outside diameter (mm)	B	16			25			32			42			56			66.5			82			102			136.5		
Hub length (mm)	C	9			9			9			10			16			18			20			40			25		
Inside diameter (mm)	D	9			15			18			25			32			38			45			60			80		
Inside diameter of elastomer (mm)	D_E	6.2			10.2			14.2			19.2			26.2			29.2			36.2			46.2			60.5		
Moment of inertia (10^{-3} kgm^2)	J_1/J_2	0.0001			0.0005			0.002			0.008			0.03			0.05			0.1			0.6			1.1		
Approx. weight (kg)		0.007			0.02			0.04			0.09			0.21			0.33			0.58			1.38			2.09		
Speed standard (min^{-1})		15,000			15,000			13,000			12,500			11,000			10,000			9,000			8,000			4,000		

For information on shaft misalignment, torsional stiffness, and other details about the elastomer inserts see pages 66 + 67.

ORDERING EXAMPLE	EKZ	60	A	XX
Model	●			
Size		●		
Elastomer insert type			●	

Special designation only (e.g. non-standard length).

For custom features place an XX at the end of the part number and describe the special requirements (e.g. EKZ/60/A/XX; XX=anodized aluminum)

WORKS WITH FULL PRODUCT RANGE



EK1



EK2

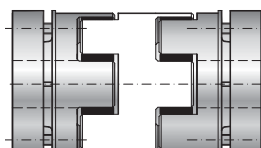

EK6

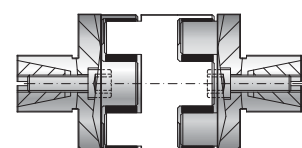

EK7





SIZES FROM 0.1 - 2,800 Nm BACKLASH FREE SAFETY COUPLINGS

GENERAL INFORMATION ABOUT R+W SAFETY COUPLINGS:



SERVICE LIFE

As long as the technical limits are not exceeded these couplings are wear and maintenance free.

FIT CLEARANCE

Overall shaft / hub clearance of 0.01 - 0.05 mm

SPECIAL SOLUTIONS

Various materials, tolerances, dimensions and performance ratings available for custom applications on request.

ATEX (Optional)

For use in hazardous zones 1/21 and 2/22, these safety couplings have been authorized under directive 94/9/EG and are available with certification.

SK**SL****ES**

BACKLASH FREE SAFETY COUPLINGS

SIZES FROM 0.1 - 2,800 Nm

MODEL

FEATURES

SK1

with conical clamping bushing (or clamping hub in smaller sizes) for indirect drives from 0.1 - 2,800 Nm

- ▶ integral bearing to support sprockets, gears, and other drive elements
- ▶ compact simple design
- ▶ adjustable torque settings

Pages 90-91

SKN

with clamping hub for indirect drives from 5 - 1,800 Nm

- ▶ integral bearing to support sprockets, gears, and other drive elements
- ▶ compact simple design
- ▶ adjustable torque settings

Pages 92-93

SKP

with keyway mounting for indirect drives from 0.1 - 2,800 Nm

- ▶ integral bearing to support sprockets, gears, and other drive elements
- ▶ compact simple design
- ▶ adjustable torque settings

Pages 94-95

SLN

with clamping hub for indirect drives from 10 - 700 Nm

- ▶ integral bearing to support sprockets, gears, and other drive elements
- ▶ adjustable torque settings
- ▶ ultra compact, low inertia version

Page 96

SLP

with keyway mounting for indirect drives from 10 - 700 Nm

- ▶ integral bearing to support sprockets, gears, and other drive elements
- ▶ adjustable torque settings
- ▶ ultra compact, low inertia version

Page 97

MODEL

FEATURES

SK2



with clamping hubs and bellows coupling for direct drives from 0.1 - 1,800 Nm

Page 98

- ▶ easy to mount
- ▶ compensation for shaft misalignment
- ▶ adjustable torque settings

SL2



with clamping hubs and bellows coupling for direct drives from 10 - 400 Nm

Page 99

- ▶ easy to mount
- ▶ compensation for shaft misalignment
- ▶ adjustable torque settings
- ▶ ultra compact, low inertia version

SK3



with conical clamping bushings and bellows coupling for direct drives from 5 - 2,800 Nm

Page 100

- ▶ high clamping pressure
- ▶ compensation for shaft misalignment
- ▶ adjustable torque settings

SK5



with clamping hubs, bellows coupling, and blind mate system for direct drives from 0.1 - 850 Nm

Page 101

- ▶ very easy to mount and dismount
- ▶ electrically and thermally isolating
- ▶ adjustable torque settings

SK**SL****ES**

BACKLASH FREE SAFETY COUPLINGS

SIZES FROM 0.1 - 2,800 Nm

MODEL

FEATURES

ES2

with clamping hubs and elastomer coupling for direct drives from 1 - 1,800 Nm

Page 102

- ▶ easy to mount
- ▶ vibration damping
- ▶ compensation for shaft misalignment
- ▶ adjustable torque settings

SLE

with clamping hubs and elastomer coupling for direct drives from 10 - 700 Nm

Page 103

- ▶ easy to mount
- ▶ vibration damping
- ▶ compensation for shaft misalignment
- ▶ adjustable torque settings
- ▶ ultra compact, low inertia version

ESL

with keyway mounting and elastomer coupling for direct drives from 1 - 150 Nm

Pages 104-105

- ▶ low cost design
- ▶ vibration damping
- ▶ wear resistant ratcheting ball design

ACCESSORIES

Accessories for safety couplings

Pages 107-111

GENERAL INFORMATION

SAFETY COUPLINGS

AVAILABLE FUNCTION SYSTEMS

SAFETY COUPLINGS

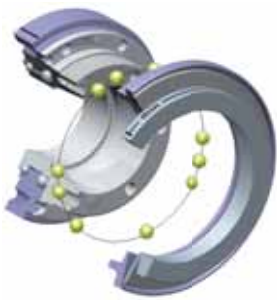

SINGLE POSITION

Standard Version

- ▶ after the overload condition has been removed the clutch will automatically re-engage precisely at its original orientation
- ▶ maintains synchronous shaft positioning
- ▶ switch plate moves at disengagement to signal overload
- ▶ patented preload for zero backlash; suitable for high precision drives

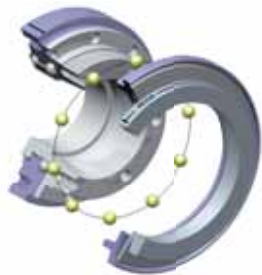

MULTI-POSITION

- ▶ after the overload condition has been removed the clutch will automatically re-engage at one of multiple angular intervals
- ▶ immediate availability of the machine after overload disengagement
- ▶ switch plate moves at disengagement to signal overload
- ▶ standard re-engagement interval is 60 degrees
- ▶ optional re-engagement intervals of 30, 45, 90, 120 degrees
- ▶ patented preload for zero backlash; suitable for high precision drives

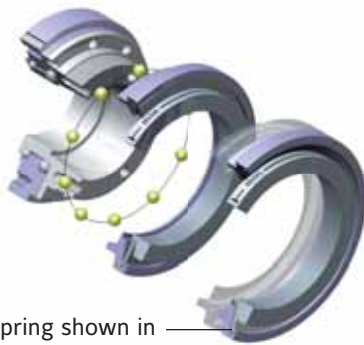

spring shown in disengaged state

FULL DISENGAGEMENT

- ▶ spring snaps over center, eliminating residual force on the ball-detent system
- ▶ complete separation at overload, allowing shafts to spin freely until they are stopped
- ▶ switch plate moves at disengagement to signal overload
- ▶ coupling requires manual re-engagement at multiple available intervals (60 degrees standard; alternate engagement intervals on request)
- ▶ well suited to higher speed applications

Note: Coupling can be disengaged manually. Contact R+W for details.

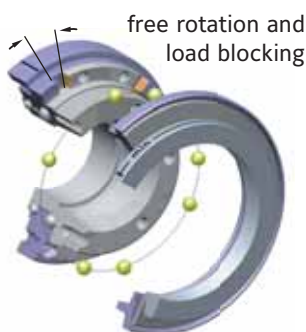

free rotation and load blocking

LOAD HOLDING / LOAD BLOCKING

- ▶ overload detection device
- ▶ only limited free rotation after overload disengagement, beyond which the clutch is fully blocked
- ▶ re-engages automatically when reversed back into original disengagement position
- ▶ switch plate moves at disengagement to signal overload
- ▶ useful in lift systems and other applications where the load must be supported after a brief torque release

GENERAL INFORMATION

SAFETY COUPLINGS

SINGLE POSITION
MULTI-POSITION
LOAD HOLDING

Note: Automatic re-engagement only occurs at low speed.

GENERAL INFORMATION

R+W safety couplings operate as spring loaded ball-detent clutches. They protect drive components (e.g. motors, transmissions, and spindles) from damage caused by machine crashes and other forms of overload.

- ▶ The torque is transmitted by hardened balls (4) loaded into conical detents (5).
- ▶ The balls are loaded into the detents by the spring disc system (2) across the switch plate (3).

- ▶ The disengagement torque is continuously adjustable via the torque adjustment nut (1).
- ▶ At overload the balls exit their detents, moving the switch plate (3) and disc spring system (2) back away from the detents, separating the input from the output of the safety coupling.
- ▶ The movement of the switch plate (3) can be detected by a proximity switch (6) to signal the drive to shut down.

FUNCTION OF THE BALL-DETENT SYSTEM

SK **SL** **ES2**

SINGLE POSITION / MULTI-POSITION

In these designs the disc spring system continues to apply a light residual pressure when in its disengaged state. This pressure is sufficient to cause automatic re-engagement after the torque has been reduced to a level below the torque setting of the safety coupling.

SK **ES2**

LOAD HOLDING / LOAD BLOCKING

The input and output of the safety coupling are only allowed limited free rotation after disengagement. This free rotation is sufficient to allow the switch plate to move and the overload condition to be signaled (see page 85).

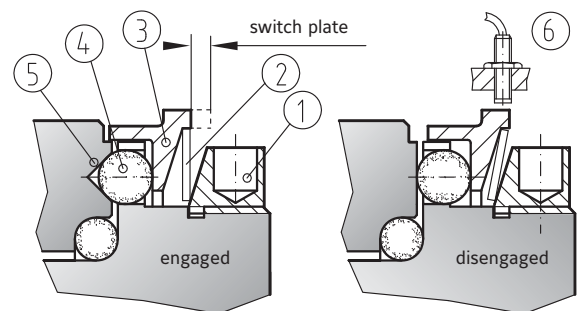

- ① Torque adjustment nut ③ Switch plate ⑤ Conical detent
- ② Disc spring system ④ Drive ball ⑥ Proximity switch

GENERAL INFORMATION

SAFETY COUPLINGS

FULL DISENGAGEMENT

Only attempt re-engagement when the machine is stopped.

FUNCTION OF THE BALL-DETENT SYSTEM

SK

ES2

FULL DISENGAGEMENT

In the full disengagement version the spring system (7) snaps over center, eliminating residual force on the ball-detent system. This causes a complete separation at overload, allowing shafts to spin freely until they are stopped.

- Re-engagement must be performed manually (see figure at right).

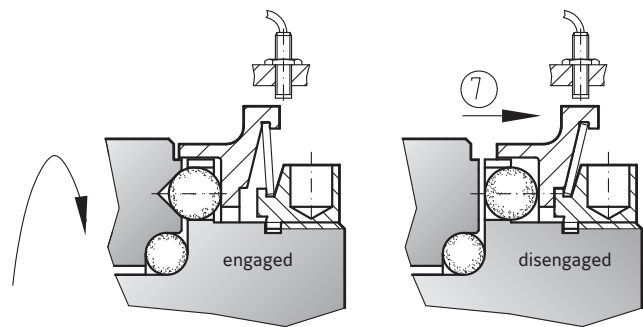

BALL-DETENT CLUTCHES ARE THE SAME DESIGN IN THE SK AND ES2 SIZES

The R+W full disengagement safety coupling can be re-engaged at any of 6 intervals by pressing the spring system back into its locked position. The re-engagement intervals are indicated by reference markings (8) on the coupling.

From size 60 and up a recess is included in the torque adjustment nut, allowing for 2 levers to be used in a self contained fashion, as shown in the figure on the right.

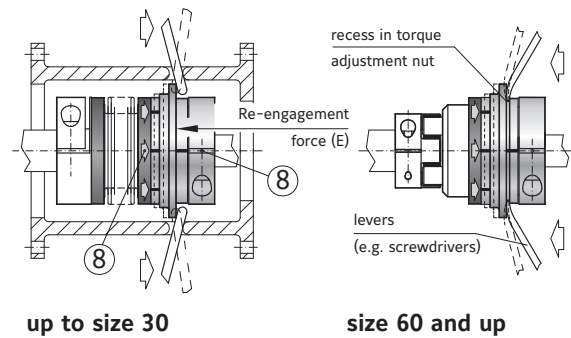

SAFETY COUPLINGS
SK | ES | SL

GENERAL INFORMATION

SAFETY COUPLINGS

BEHAVIOR AND CHARACTERISTICS

SPRING SYSTEM

R+W safety couplings work exclusively with a disc spring system with a special characteristic. Prior to the torque adjustment nut coming into contact with the disc springs and applying pressure (1) no torque transmission is possible. Once the spring is loaded, the active range of the spring system had been reached, with the spring rate declining as further compression takes place, both prior to, and during disengagement (2). Once completely depressed, the spring system is rigid (3).

As the safety coupling is in the process of disengaging, the spring force continues to decline. This advantage guarantees the shortest possible disengagement times (1-2 msec), very low wear while running disengaged, and very low residual friction in general (2-5%).

IMPORANT!

The minimum and maximum torque values of the R+W safety couplings are at the limits of the active range of the disc spring system. Therefore it is critical not to exit the manufacturer specified torque adjustment range.

ROTATIONAL SPEED

The rotational speed at disengagement significantly influences the service life of the coupling. At lower speeds the coupling can handle many thousands of disengagements with no degradation to performance. Please contact R+W for details if applying the safety coupling to a high speed shaft.

WEAR

In its engaged state the safety coupling is completely wear free. Service life can be extended significantly by taking measures to stop shaft rotation quickly after disengagement.

MAINTENANCE

The R+W safety couplings are maintenance free and lubricated for life.

SPRING CHARACTERISTIC

special design

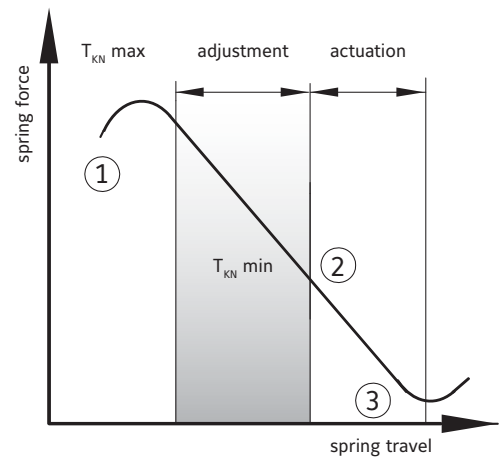

DISENGAGEMENT

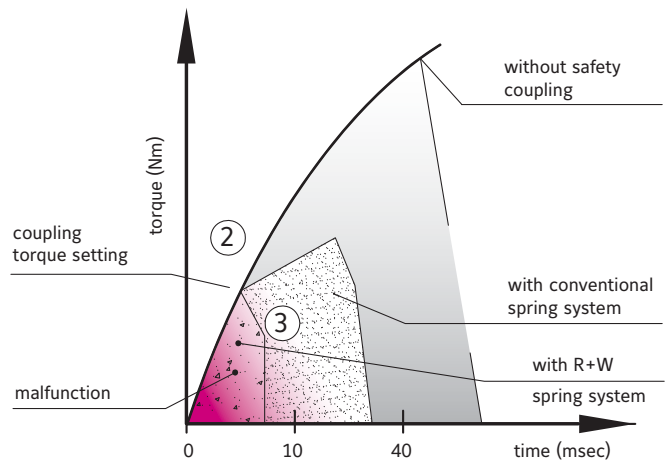

SAFETY COUPLING WITH SEAL (OPTIONAL)

Benefits of sealing:

- ▶ Protection from harmful contaminants
- ▶ No leakage of grease
- ▶ Recommended for harsh environments or clean room / sanitary application requirements

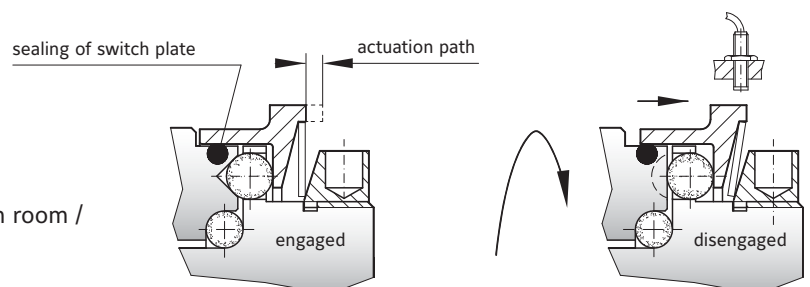

GENERAL INFORMATION

SAFETY COUPLINGS

RADIAL LOADS

SAFETY COUPLINGS

SK1

SKN

SKP

SLN

SLP

The models shown above have an integral bearing (1) to support the drive attachment (e.g. timing belt or chain sprocket, gear, or hand wheel). The maximum radial load (2) is listed in the table below.

If the center of the overhung load is located within dimension range (S) no additional bearing support is necessary. For offset mounting additional bearings can be used to support the load. This is useful in cases where the attached component is too small to fit over the coupling output flange or has a large width.

Depending on the installation space, ball, roller or needle bearings can all be used.

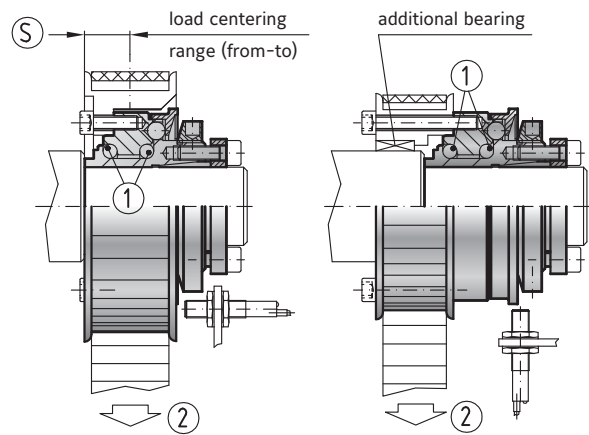

SIZE SK1/SKN/SKP	1.5	2	4.5	10	15	30	60	150	200	300	500	800	1500	2500
Max. radial load (N)	50	100	200	500	1400	1800	2300	3000	3500	4500	5600	8000	12000	20000
(S) from-to (mm)	3-6	5-8	5-11	6-14	7-17	10-24	10-24	12-24	12-26	12-28	16-38	16-42	20-50	28-60

SIZE SLN/SLP	30	60	150	300
Max. radial load (N)	1800	2300	3000	4500
(S) from-to (mm)	4-14	5-18	6-20	6-23

SK1

WITH CONICAL CLAMPING BUSHING

0.1 - 2,800 Nm



Timing belt or chain sprocket only included upon request.

ABOUT

MATERIAL

- ▶ **Clutch system:** hardened steel
- ▶ **Clamping ring size 1.5 - 10:** aluminum
- ▶ **Conical clamping bushing size 15 - 2500:** steel

DESIGN

Size 1.5 - 10 with clamping ring and a single clamping screw.
Size 15 - 2500 with conical clamping bushing and six screws.

Clutch system: spring loaded ball-detent principle. Operable temperature range from -30 to +120° C.

AVAILABLE FUNCTION SYSTEMS

- ▶ **W** = Single position / automatic re-engagement (standard)
- ▶ **D** = Multi-position / automatic re-engagement
- ▶ **G** = Load holding / load blocking
- ▶ **F** = Full disengagement / manual re-engagement

MINIATURE DESIGN | SIZE 1.5 - 10

Standard with clamping collar

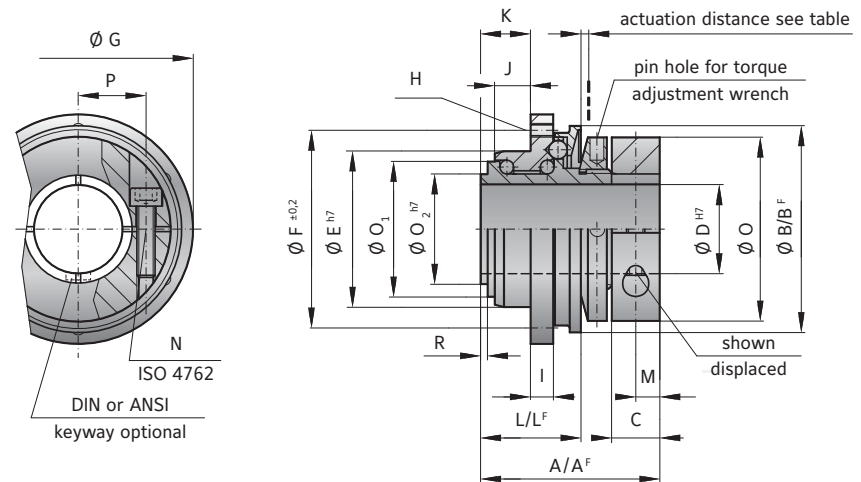

STANDARD DESIGN | SIZE 15 - 2,500

Standard with conical clamping bushing

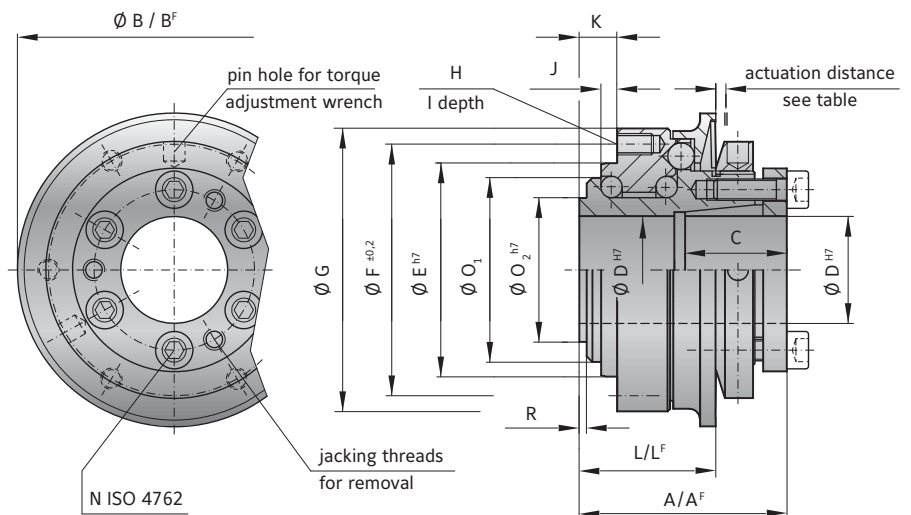

MODEL SK1

MINIATURE DESIGN

SIZE		1.5	2	4.5	10	15	30	60	150	200	300	500	800	1500	2500
Adjustment range available from - to (approx. values) (Nm)	T _{KN}	0.1-0.6 0.4-1 0.8-2	0.2-1.5 0.5-2.2 1.5-3.5	1-3 2-4.5 3-7	2-6 4-12 7-18	5-15 12-25 20-40 35-70	5-20 10-30 20-60 50-100	10-30 25-80 50-115	20-70 45-150 80-225	30-90 60-160 140-280 250-400	100-200 150-240 220-440	80-200 200-350 320-650	400-650 500-800 650-950	600-800 700-1200 1000-1800	1500-2000 2000-2500 2300-2800
Adjustment range available from - to (approx. values) ("F" Version) (Nm)	T _{KN}	0.3-0.8 or 0.6-1.3	0.5-2	2.5-4.5	2-5 4-10 8-15	7-15	8-20 or 16-30	10-30 20-40 30-60	20-60 40-80 80-150	80-140 or 130-200	120-180 160-300 300-450	50-150 100-300 250-500	200-400 or 450-850	1000-1250 or 1250-1500	1400-2200 or 1800-2700
Overall length (mm)	A	23	28	32	39	40	50	54	58	63	70	84	95	109	146
Overall length ("F" Version) (mm)	A ^F	23	28	32	39	40	50	54	58	66	73	88	95	117	152
Actuation ring Ø (mm)	B	23	29	35	45	55	65	73	92	99	120	135	152	174	242
Actuation ring Ø, ("F" Version) (mm)	B ^F	24	32	42	51.5	62	70	83	98	117	132	155	177	187	258
Clamping fit length (mm)	C	7	8	11	11	19	22	27.5	32	32	41	41	49	61	80
Inner diameter from Ø to Ø H7 (mm)	D	4-8	4-12	5-14	6-20	8-22	12-22	12-29	15-37	20-44	25-56	25-56	30-60	35-70	50-100
Pilot diameter h7 (mm)	E	14	22	25	34	40	47	55	68	75	82	90	100	125	168
Bolt-hole circle diameter ± 0.2 (mm)	F	22	28	35	43	47	54	63	78	85	98	110	120	148	202
Flange outside diameter -0.2 (mm)	G	26	32	40	50	53	63	72	87	98	112	128	140	165	240
Thread	H	4xM2	4xM2.5	6xM2.5	6xM3	6xM4	6xM5	6xM5	6xM6	6xM6	6xM8	6xM8	6xM10	6xM12	6xM16
Thread depth (mm)	I	3	4	4	5	6	8	9	10	10	10	12	15	16	24
Centering length -0.2 (mm)	J	2.5	3.5	5	8	3	5	5	5	5	6	9	10	13.5	20
Distance (mm)	K	5	6	8	11	8	11	11	12	12	15	21	19	25	34
Distance (mm)	L	11	15	17	22	27	35	37	39	44	47	59	67	82	112
Distance, ("F" Version) (mm)	L ^F	11.5	16	18	24	27	37	39	41.5	47	51.5	62	75	94	120
Distance	M	3.5	4	5	5										
Screw ISO 4762	N	1xM2.5	1xM3	1xM4	1xM4	6xM4	6xM5	6xM5	6xM6	6xM6	6xM8	6xM8	6xM10	6xM12	6xM16
Tightening torque (Nm)		1	2	4	4.5	4	6	8	12	14	18	25	40	70	120
Outside diameter clamp ring Ø (mm)	O	20	25	32	40										
Diameter (mm)	O ₁	13	18	21	30	35	42	49	62	67	75	84	91	112	154
Diameter h7 (mm)	O ₂	11	14	17	24	27	32	39	50	55	65	72	75	92	128
Distance between centers (mm)	P	6.5	8	10	15										
Distance (mm)	R	1	1.3	1.5	1.5	2.5	2.5	2.5	2.5	3	3	4	4	4.5	6
Moment of inertia (10 ⁻³ kgm ²)	J _{ges}	0.01	0.02	0.05	0.07	0.15	0.25	0.50	1.60	2.70	5.20	8.6	20	31.5	210
Approx. weight (kg)		0.03	0.065	0.12	0.22	0.4	0.7	1.0	1.3	2.0	3.0	4.0	5.5	10	28
Actuation distance (mm)		0.7	0.8	0.8	1.2	1.5	1.7	1.7	1.9	2.2	2.2	2.2	2.2	3.0	3.0

A^F, B^F, L^F = Full disengagement / manual re-engagement version (F)

ORDERING EXAMPLE	SK1	10	W	12.7	4	2 - 6	XX
Model	●						Special designation only (e.g. special bore / keyway dimensions).
Size		●					
Function system			●				
Bore D1 H7				●			
Disengagement torque Nm					●		
Torque adjustment range Nm						●	
For custom features place an XX at the end of the part number and describe the special requirements (e.g. SK1/10/W/12.7/4/2-6/XX; XX=stainless steel)							

WITH CLAMPING COLLAR

5 - 1,800 Nm



Timing belt or chain sprocket only included upon request.

ABOUT

MATERIAL

- ▶ **Clutch system:** hardened steel
- ▶ **Clamping collar:** up to size 500 aluminum, size 800 and up steel

DESIGN

With clamping ring and one clamping screw. Clutch system: spring loaded ball-detent principle. Operable temperature range from -30 to +120° C.

AVAILABLE FUNCTION SYSTEMS

- ▶ **W** = Single position / automatic re-engagement (standard)
- ▶ **D** = Multi-position / automatic re-engagement
- ▶ **G** = Load holding / load blocking
- ▶ **F** = Full disengagement / manual re-engagement

STANDARD DESIGN | SIZE 15 - 1,500

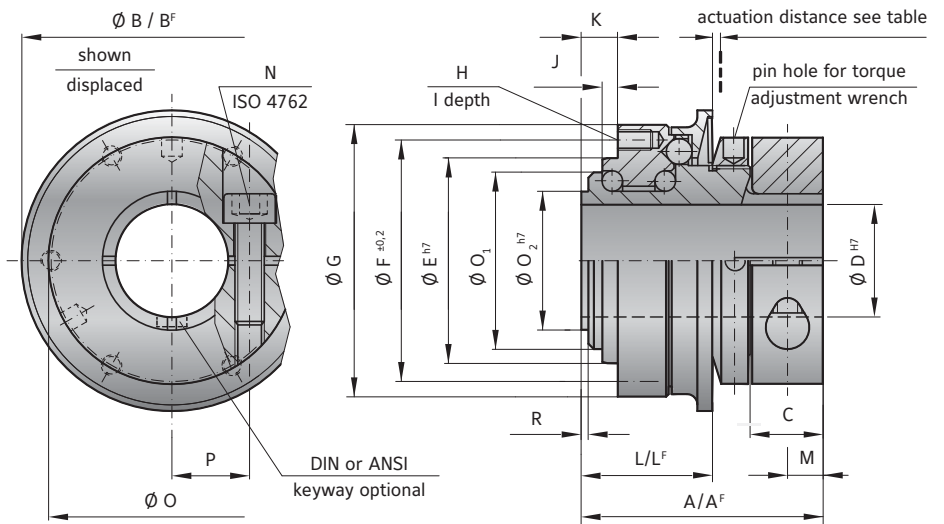

MODEL SKN

SIZE		15	30	60	150	200	300	500	800	1500
Adjustment range available from - to (approx. values)	(Nm) T _{KN}	5-10 or 8-20	10-25 or 20-40	10-30 or 25-80	20-70 45-150 80-180	30-90 60-160 120-240	100-200 150-240 200-320	80-200 200-350 300-500	400-650 500-800 600-850	600-800 700-1200 1000-1800
Adjustment range available from - to (approx. values) ("F" Version)	(Nm) T _{KN}	7-15	8-20 or 16-30	10-30 20-40 30-60	20-60 40-80 80-150	80-140 or 130-200	120-180 or 160-300	50-150 100-300 250-500	200-400 or 450-800	1000-1250 or 1250-1500
Overall length	(mm) A	47	59	65	71	80	84	101	115	145
Overall length, ("F" Version)	(mm) A ^F	47	59	65	73	83	87	107	126	160
Actuation ring Ø	(mm) B	55	65	73	92	99	120	135	152	174
Actuation ring Ø, ("F" Version)	(mm) B ^F	62	70	83	98	117	132	155	177	187
Clamping fit length	(mm)	13.5	16	20	23	26	26	30	35	46
Inside diameter from Ø to Ø H7	(mm) D	12-22	14-25.4	16-32	19-40	24-44	30-56	35-60	40-62	50-72
Inside diameter from Ø to Ø H7 with keyway	(mm)	8-19	12-22	12-30	15-36	20-44	25-50	25-58	30-56	35-65
Pilot diameter h7	(mm) E	40	47	55	68	75	82	90	100	125
Bolt-hole circle diameter ± 0.2	(mm) F	47	54	63	78	85	98	110	120	148
Flange outside diameter -0.2	(mm) G	53	63	72	87	98	112	128	140	165
Thread	H	6xM4	6xM5	6xM5	6xM6	6xM6	6xM8	6xM8	6xM10	6xM12
Thread depth	(mm) I	6	8	9	10	10	10	12	15	16
Centering length -0.2	(mm) J	3	5	5	5	5	6	9	10	13.5
Distance	(mm) K	8	11	11	12	12	15	21	19	25
Distance	(mm) L	27	35	37	39	44	47	59	67	82
Distance, ("F" Version)	(mm) L ^F	27	37	39	41.5	47	51.5	62	75	94
Distance	M	6.5	7.5	9.5	11	13	13	14.5	18	22.5
Screw ISO 4762	N	M5	M6	M8	M10	M12	M12	M14	M16	M20
Tightening torque		8	15	40	70	120	130	210	270	500
Clamp ring Ø	O	49	55	67	85	94	110	121	134	157
Diameter	(mm) O ₁	35	42	49	62	67	75	84	91	112
Diameter h7	(mm) O ₂	27	36	39	50	55	65	72	75	92
Distance between centers	(mm) P	17.5	19	23.5	30	32.5	39	43.5	45	52
Distance	(mm) R	2.5	2.5	2.5	2.5	3	3	4	4	4.5
Moment of inertia (10 ⁻³ kgm ²)	J _{ges}	0.15	0.25	0.50	1.60	2.70	5.20	8.60	20	31.5
Approx. weight	(kg)	0.4	0.7	1.0	1.3	2.0	3.0	4.0	5.5	10
Actuation distance	(mm)	1.5	1.5	1.7	1.9	2.2	2.2	2.2	2.2	3.0

A^F, B^F, L^F = Full disengagement / manual re-engagement version (F)

ORDERING EXAMPLE	SKN	60	W	19.05	60	25-80	XX
Model	●						Special designation only (e.g. special bore / keyway dimensions).
Size		●					
Function system			●				
Bore D1 H7				●			
Disengagement torque Nm					●		
Torque adjustment range Nm						●	
For custom features place an XX at the end of the part number and describe the special requirements (e.g. SKN/60/W/19.05/60/25-80/XX; XX=stainless steel)							

SAFETY COUPLINGS
SK | ES | SL



Timing belt or chain sprocket only included upon request.

ABOUT

MATERIAL

► **Clutch system:** hardened steel

DESIGN

With DIN 6885 or ANSI B17.1 keyway.
Clutch system: spring loaded ball-detent principle. Operable temperature range from -30 to +120° C.

AVAILABLE FUNCTION SYSTEMS

- W = Single position / automatic re-engagement (standard)
- D = Multi-position / automatic re-engagement
- G = Load holding / load blocking
- F = Full disengagement / manual re-engagement

MINIATURE DESIGN | SIZE 1.5 - 10

Standard with keyway mounting

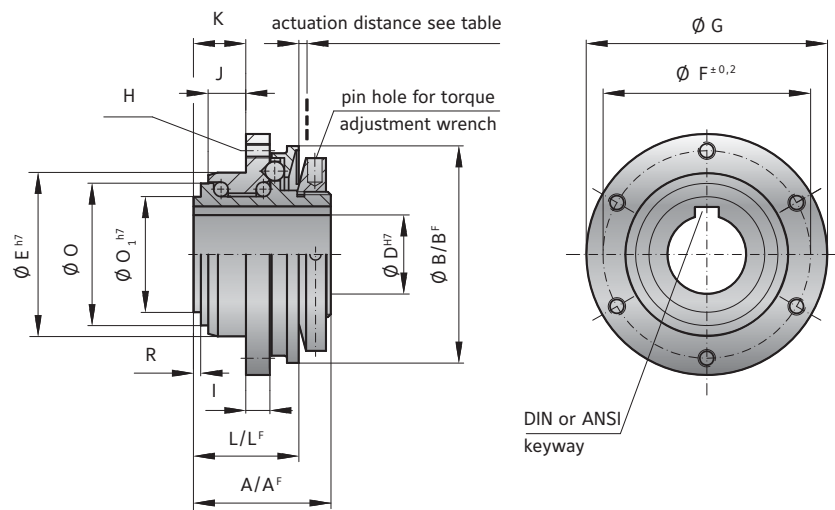

STANDARD DESIGN | SIZE 15 - 2,500

Standard with keyway mounting

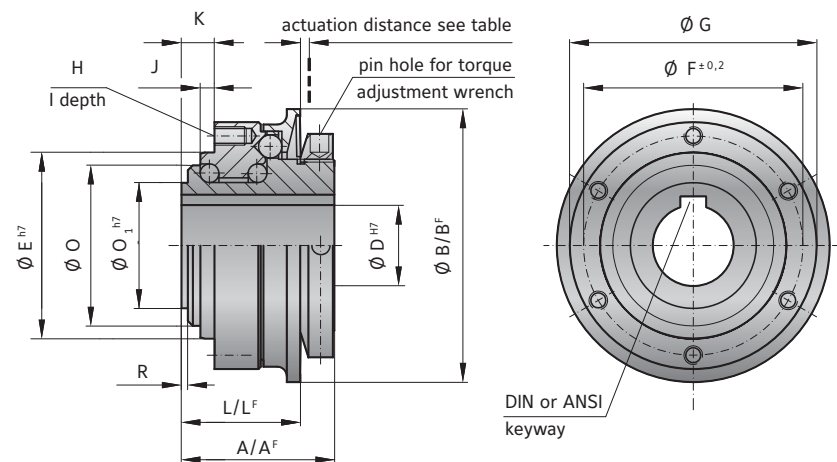

MODEL SKP

MINIATURE DESIGN

SIZE		1.5	2	4.5	10	15	30	60	150	200	300	500	800	1500	2500
Adjustment range available from - to (approx. values)	(Nm) T_{KN}	0.1-0.6 0.4-1 0.8-2	0.2-1.5 0.5-2.2 1.5-3.5	1-3 2-4.5 3-7	2-6 4-12 7-18	5-15 12-25 20-40 35-70	5-20 10-30 20-60 50-100	10-30 25-80 50-115	20-70 45-150 80-225	30-90 60-160 140-280 250-400	100-200 150-240 220-440	80-200 200-350 320-650	400-650 500-800 650-950	600-800 700-1200 1000-1800	1500-2000 2000-2500 2300-2800
Adjustment range available from - to (approx. values) ("F" Version)	(Nm) T_{KN}	0.3-0.8 or 0.6-1.3	0.5-2	2.5-4.5	2-5 4-10 8-15	7-15	8-20 or 16-30	10-30 20-40 30-60	20-60 40-80 80-150	80-140 or 130-200	120-180 160-300 300-450	50-150 100-300 250-400	200-400 or 450-850	1000-1250 or 1250-1500	1400-2200 or 1800-2700
Overall length A	(mm) A	15.5	20	22	28	34	43	46	48.5	54	57	71.5	80	93	135
Overall length ("F" Version)	(mm) A ^F	15.5	20	22	28	34	43	46	48.5	57	60	75	91	110	141
Actuation ring \varnothing	(mm) B	23	29	35	45	55	65	73	92	99	120	135	152	174	242
Actuation ring \varnothing , ("F" Version)	(mm) B ^F	24	32	42	51.5	62	70	83	98	117	132	155	177	187	258
Inner diameter from \varnothing to \varnothing H7	(mm) D	4-8	4-10	5-12*	6-16	8-19	12-25.4	12-28	15-38	20-44	25-50	25-58	30-60	35-73	50-95
Pilot diameter h7	(mm) E	14	22	25	34	40	47	55	68	75	82	90	100	125	168
Bolt-hole circle diameter ± 0.2	(mm) F	22	28	35	43	47	54	63	78	85	98	110	120	148	202
Flange outside diameter -0.2	(mm) G	26	32	40	50	53	63	72	87	98	112	128	140	165	240
Thread	H	4xM2	4xM2.5	6xM2.5	6xM3	6xM4	6xM5	6xM5	6xM6	6xM6	6xM8	6xM8	6xM10	6xM12	6xM16
Thread depth	(mm) I	3	4	4	5	6	8	9	10	10	10	12	15	16	24
Centering length -0.2	(mm) J	2.5	3.5	5	8	3	5	5	5	5	6	9	10	13.5	20
Distance	(mm) K	5	6	8	11	8	11	11	12	12	15	21	19	25	34
Distance	(mm) L	11	15	17	22	27	35	37	39	44	47	59	67	82	112
Distance, ("F" Version)	(mm) L ^F	11.5	16	18	24	27	37	39	41.5	47	51.5	62	75	94	120
Diameter	(mm) O	13	18	21	30	35	42	49	62	67	75	84	91	112	154
Diameter h7	(mm) O ₁	11	14	17	24	27	32	39	50	55	65	72	75	92	128
Distance	(mm) R	1	1.3	1.5	1.5	2.5	2.5	2.5	2.5	3	3	4	4	4.5	6
Moment of inertia (10^{-3}kgm^2)	J_{ges}	0.01	0.02	0.05	0.07	0.15	0.25	0.50	1.60	2.70	5.20	8.6	20	31.5	210
Approx. weight (kg)		0.03	0.065	0.12	0.22	0.4	0.7	1.0	1.3	2.0	3.0	4.0	5.5	10	28
Actuation distance (mm)		0.7	0.8	0.8	1.2	1.5	1.5	1.7	1.9	2.2	2.2	2.2	2.2	3.0	3.0

A^F, B^F, L^F = Full disengagement / manual re-engagement version (F) * \varnothing 12 mm only available with shallow keyway (height = 1.2mm^{+0.2})

KEYWAY ACCORDING TO DIN 6885 (R+W STANDARD)

D ₁ from to	6 8	8 10	10 12	12 17	17 22	22 30	30 38	38 44	44 50	50 58	58 65	65 75	75 85	85 95	95 110
b ^{J59}	2	3	4	5	6	7	8	8	9	10	11	12	14	14	16
h	1.2	1.8	2.5	3	3.5	4	5	5	5.5	6	7	7.5	9	9	10
t ₁	1	1.4	1.8	2.3	2.8	3.3	3.3	3.3	3.8	4.3	4.4	4.9	5.4	5.4	6.4
t ₂ ^{+0.1/+0.2}	1	1.4	1.8	2.3	2.8	3.3	3.3	3.3	3.8	4.3	4.4	4.9	5.4	5.4	6.4

Bore diameters specified as common inch sizes receive standard keyways according to ANSI B17.1. Special keyway dimensions are also available upon request.

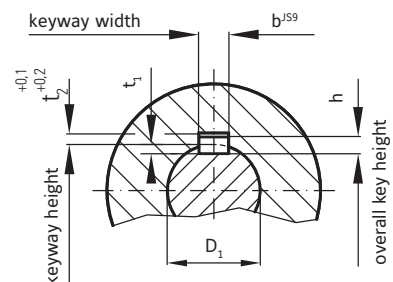

ORDERING EXAMPLE	SKP	10	W	15.88	4	2-6	XX
Model	●						
Size		●					
Function system			●				
Bore D1 H7				●			
Disengagement torque Nm					●		
Torque adjustment range Nm						●	
For custom features place an XX at the end of the part number and describe the special requirements (e.g. SKP/10/W/15.88/4/2-6/XX; XX=stainless steel)							

Special designation only (e.g. special bore / keyway dimensions).

SLN

WITH CLAMPING COLLAR

10 - 700 Nm



ABOUT

DESIGN

With clamping collar and a single clamping screw.
Clutch system: spring loaded ball-detent principle. Operable temperature range from -30 to +120° C.

AVAILABLE FUNCTION SYSTEMS

- ▶ W = Single position / automatic re-engagement (standard)
- ▶ D = Multi-position / automatic re-engagement

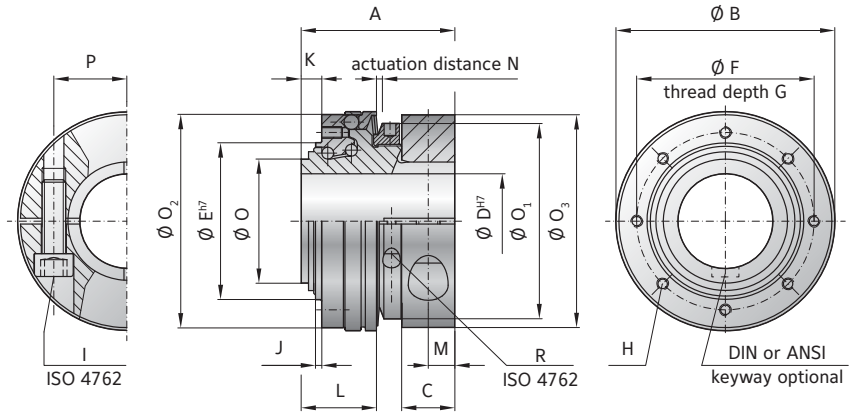

MODEL SLN

SIZE			30	60	150	300
Adjustment range* from - to (Nm)	T _{KN}		10-35 30-80 40-135	30-80 60-120 100-200	40-100 100-200 150-300	200-350 300-450 400-550 550-700
Overall length (mm)	A		45	53	63	72
Actuation ring Ø (mm)	B		63	74	92	118
Clamping fit length (mm)	C		15	18	22	24
Bore diameter from Ø to Ø H7 (mm)	D		12-30	16-35	19-48	22-60
Bore diameter with keyway DIN 6885 from Ø to Ø H7 (mm)	D		12-25.4	16-32	19-44	22-54
Pilot diameter h7 (mm)	E		43	53	68	85
Bolt-hole circle diameter ± 0.2 (mm)	F		48	60	75	95
Thread depth +1 (mm)	G		5	6	7	9
Fastening threads	H		8x M4	8x M4	8x M5	8x M6
Screw ISO 4762	I		M6	M8	M10	M12
Tightening torque (Nm)	I		15	40	75	130
Centering length -0.2 (mm)	J		2	2	3	3
Distance (mm)	K		6	7	9	9
Distance to actuation ring edge (mm)	L		23	26	32	36
Distance (mm)	M		7.5	9	11	12
Actuation distance (mm)	N		1.3	1.5	1.8	2
Ø Base element (mm)	O		35	42	54	70
Ø Adjustment nut (mm)	O ₁		55	66	82	100
Ø Flange -0.2 (mm)	O ₂		58	72	87	110
Ø Clamp ring (mm)	O ₃		59	72	90	112
Distance between centers (mm)	P		21.5	25	33	41
Adjustment nut's clamp screw ISO 4762	R		M3	M3	M3	M4
Tightening torque (Nm)	R		2	2	2	4.5
Approx. weight (kg)			0.3	0.5	0.8	1.5
Approx. moment of inertia at D max (10 ⁻³ Kg·m ²)	J _{ges}		0.15	0.3	1	3

*Maximum transmittable torque of the clamping hub depends on the bore diameter / see table below

MAXIMUM TRANSMITTABLE TORQUE IN RELATION TO BORE DIAMETER

SIZE	Ø 12	Ø 15	Ø 20	Ø 25	Ø 30	Ø 35	Ø 40	Ø 45	Ø 50	Ø 55	Ø 60
30	30	55	80	110	130						
60		80	120	160	200	220					
150			200	250	300	350	400	450			
300				350	430	510	590	670	750	830	910

Higher torque possible with keyway.

ABOUT

DESIGN

With DIN 6885 or ANSI B17.1 keyway.
Clutch system: spring loaded ball-detent principle. Operable temperature range from -30 to +120° C.

AVAILABLE FUNCTION SYSTEMS

- ▶ W = Single position / automatic re-engagement (standard)
- ▶ D = Multi-position / automatic re-engagement

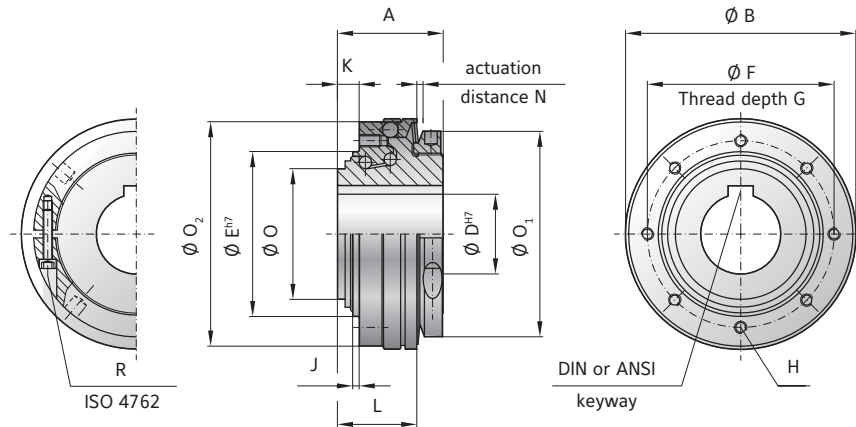

MODEL SLP

SIZE			30	60	150	300
Adjustment range* from - to	(Nm)	T _{KN}	10-35 30-80 40-135	30-80 60-120 100-200	40-100 100-200 150-300	200-350 300-450 400-550 550-700
Overall length	(mm)	A	30	35	41	48
Actuation ring diameter	(mm)	B	63	74	92	118
Bore diameter from Ø to Ø H7	(mm)	D	12-25.4 (28)*	16-32 (34)*	19-44 (46)*	22-54 (58)*
Pilot diameter h7	(mm)	E	43	53	68	85
Bolt-hole circle diameter ± 0.2	(mm)	F	48	60	75	95
Thread depth +1	(mm)	G	5	6	7	9
Fastening threads		H	8x M4	8x M4	8x M5	8x M6
Centering length -0.2	(mm)	J	2	2	3	3
Distance	(mm)	K	6	7	9	9
Distance to actuation ring edge	(mm)	L	23	26	32	36
Actuation distance	(mm)	N	1.3	1.5	1.8	2
Ø Base element	(mm)	O	35	42	54	70
Ø Adjustment nut	(mm)	O ₁	55	66	82	100
Ø Flange -0.2	(mm)	O ₂	58	72	87	110
Adjustment nut's clamp screw ISO 4762		R	M3	M3	M3	M4
Tightening torque	(Nm)		2	2	2	4.5
Approx. weight	(kg)		0.2	0.35	0.7	1.1
Approx. moment of inertia at D max.	(10 ⁻³ kgm ²)	J _{ses}	0.1	0.4	1.1	2.3

* maximum bore diameters shown are only available with shallow keyway according to DIN 6885/3 or special heights for inch bores

ORDERING EXAMPLE	SLN SLP	60	W	25.4	80	60-120	XX
Model	●						Special designation only (e.g. special bore / keyway dimensions).
Size		●					
Function system			●				
Bore D H7				●			
Disengagement torque Nm					●		
Torque adjustment range Nm						●	
For custom features place an XX at the end of the part number and describe the special requirements (e.g. SLN/60/W/25.4/80/60-120; XX=special dual keyway)							

SK2

WITH CLAMPING HUBS

0.1 - 1,800 Nm



ABOUT

MATERIAL

- ▶ **Bel lows:** high grade stainless steel
- ▶ **Clutch system:** hardened steel
- ▶ **Clamping hubs:** up to size 80 aluminum, size 150 and up steel

temperature range from -30 to +100° C.

DESIGN

Two clamping hubs with one clamping screw in each. Clutch system: spring loaded ball-detent principle. Operable

AVAILABLE FUNCTION SYSTEMS

- ▶ **W** = Single position / automatic re-engagement (standard)
- ▶ **D** = Multi-position / automatic re-engagement
- ▶ **G** = Load holding / load blocking
- ▶ **F** = Full disengagement / manual re-engagement

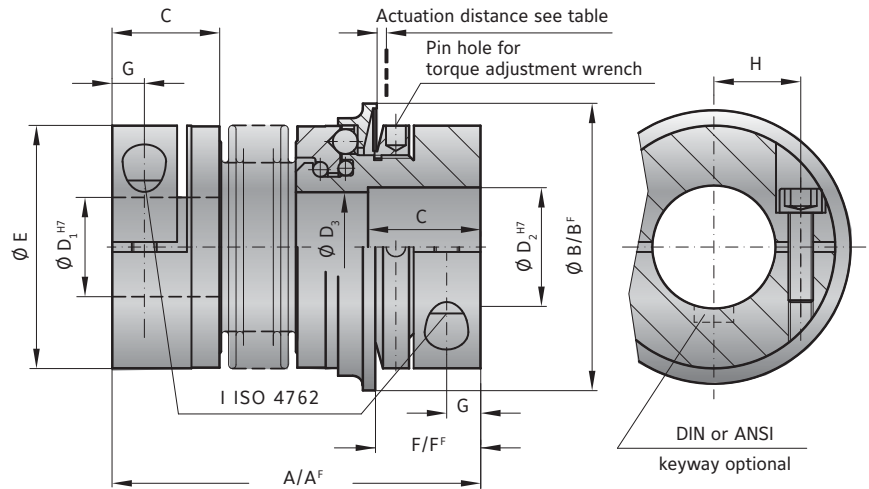

MODEL SK2

SIZE		1.5	2	4.5	10	15	30	60	80	150	200	300	500	800	1500
Adjustment range available from - to (approx. values) (Nm)	T_{KN}	0.1-0.6 0.4-1 0.8-1.5	0.2-1.5 or 0.5-2	1-3 or 3-6	2-6 or 4-12	5-10 or 8-20	10-25 or 20-40	10-30 or 25-80	20-70 or 30-90	20-70 or 45-150 80-180	30-90 60-160 120-240	100-200 150-240 200-320	80-200 200-350 300-500	400-650 500-800 650-850	650-800 700-1200 1000-1800
Adjustment range available from - to (approx. values) ("F" Version) (Nm)	T_{KN}	0.3-0.8 or 0.6-1.3	0.5-2	2.5-4.5	2-5 or 5-10	7-15	8-20 or 16-30	20-40 or 30-60	20-60 or 40-80	20-60 or 40-80 80-150	80-140 or 130-200	120-180 or 160-300	60-150 100-300 250-500	200-400 or 450-800	1000-1250 or 1250-1500
Overall length (mm)	A	42	46 51	57 65	65 74	75 82	87 95	102 112	115 127	116 128	128 140	139 153	163 177	190	223
Overall length, ("F" Version) (mm)	A ^F	42	46 51	57 65	65 74	75 82	87 95	102 112	117 129	118 130	131 143	142 156	167 181	201	232
Actuation ring Ø (mm)	B	23	29	35	45	55	65	73	92	92	99	120	135	152	174
Actuation ring Ø, ("F" Version) (mm)	B ^F	24	32	42	51.5	62	70	83	98	98	117	132	155	177	187
Clamping fit length (mm)	C	11	13	16	16	22	27	31	35	35	40	42	51	48	67
Inside diameter from Ø to Ø H7 (mm)	D ₁ /D ₂	3-9	4-12	5-14	6-20	10-26	12-30	15-32	19-42	19-42	24-45	30-60	35-60	40-75	50-80
Diameter (mm)	D ₃	9.1	12.1	14.1	20.1	21.1	24.1	32.1	36.1	36.1	42.1	58.1	60.1	60.1	68.1
Outside diameter of coupling (mm)	E	19	25	32	40	49	55	66	81	81	90	110	123	134	157
Distance (mm)	F	12	13	15	17	19	24	28	31	31	35	35	45	50	63
Distance, ("F" Version) (mm)	F ^F	11.5	12	14	16	19	22	29	31	30	33	35	43	54	61
Distance (mm)	G	3.5	4	5	5	6.5	7.5	9.5	11	11	12.5	13	17	18	22.5
Distance between centers (mm)	H	6	8	10	15	17	19	23	27	27	31	39	41	2x48	2x55
Screw ISO 4762	I	M2.5	M3	M4	M4	M5	M6	M8	M10	M10	M12	M12	M16	2xM16	2xM20
Tightening torque (Nm)	I	1	2	4	4.5	8	15	40	50	70	120	130	200	250	470
Approx. weight (kg)		0.035	0.07	0.2	0.3	0.4	0.6	1.0	2.0	2.4	4.0	5.9	9.6	14	21
Moment of inertia (10 ⁻³ kgm ²)	J _{ges}	0.01	0.01 0.01	0.02 0.02	0.06 0.07	0.10 0.15	0.27 0.32	0.75 0.80	1.80 1.90	2.50 2.80	5.10 5.30	11.5 11.8	22.8 23.0	42.0	83.0
Torsional stiffness (10 ³ Nm/rad)	C _T	0.7	1.2 1.3	7 5	9 8	20 15	39 28	76 55	129 85	175 110	191 140	420 350	510 500	780	1304
Lateral ± (mm)	max. values	0.15	0.15 0.20	0.20 0.25	0.20 0.30	0.15 0.20	0.20 0.25	0.20 0.25	0.20 0.25	0.20 0.25	0.25 0.30	0.25 0.30	0.30 0.35	0.30 0.35	0.35
Angular ± (Degree)	values	1	1 1.5	1.5 2	1.5 2	1 1.5	1 1.5	1 1.5	1 1.5	1 1.5	1 1.5	1 1.5	2 2	2 2.5	2.5
Lateral spring stiffness (N/mm)		70	40 30	290 45	280 145	475 137	900 270	1200 420	920 255	1550 435	2040 610	3750 1050	2500 840	2000	3600
Actuation distance (mm)		0.7	0.8	0.8	1.2	1.5	1.5	1.7	1.9	1.9	2.2	2.2	2.2	2.2	3

A^F, B^F, L^F = Full disengagement / manual re-engagement version (F)

Larger versions available upon request.

SL2

WITH CLAMPING HUBS

10 - 400 Nm

ABOUT

DESIGN

Clamping collar / clamping hub with one clamping screw each. Clutch system: spring loaded ball-detent principle. Special compact, high stiffness version. Operable temperature range from -30 to +100° C.

AVAILABLE FUNCTION SYSTEMS

- ▶ W = Single position / automatic re-engagement (standard)
- ▶ D = Multi-position / automatic re-engagement

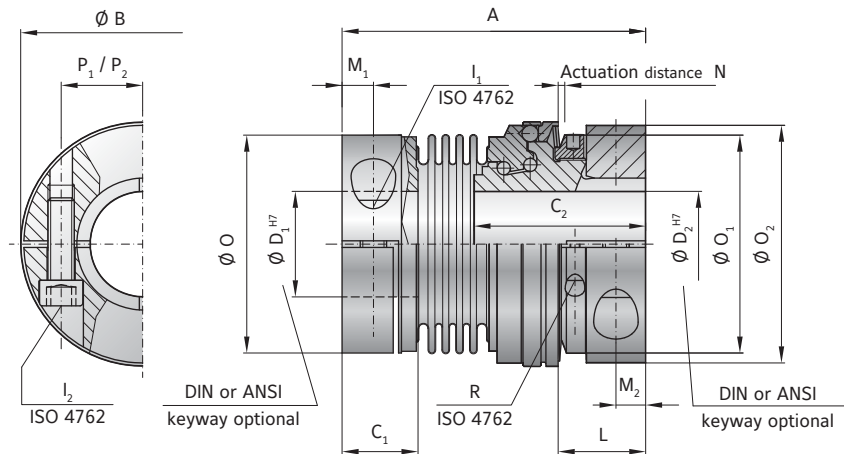

MODEL SL2

SIZE			30	60	150	300
Adjustment range* from - to	(Nm)	T _{KN}	10-35 30-80	20-50 40-100	40-100 100-200	100-250 200-350 300-400
Overall length	(mm)	A	80	93	112	126
Actuation ring diameter	(mm)	B	63	74	92	118
Hub length	(mm)	C ₁ /C ₂	21/45	23/53	28 / 63	34/72
Bore diameter from Ø to Ø H7	(mm)	D ₁ /D ₂	12-32/12-30	16-35 / 16-35	19-42 / 19-48	22-60 / 22-60
Screw ISO 4762	(mm)		M6	M8	M10	M12
Tightening torque	(Nm)	I ₁ /I ₂	15	40	75	130
Distance to actuation ring edge	(mm)	L	22	26	32	35
Distance	(mm)	M ₁ /M ₂	7.5/7.5	9.5/9	11/11	13/12
Actuation distance	(mm)	N	1.3	1.5	1.8	2
Ø Clamping hub Ø, (coupling end)	(mm)	O	55.5	66	82	110
Ø Adjustment nut	(mm)	O ₁	55	66	82	100
Clamping ring Ø, (torque limiter end)	(mm)	O ₂	59	72	90	112
Distance between centers, bellows side/safety element	(mm)	P ₁ /P ₂	20/21.5	23 / 25	27/33	39/41
Adjustment nut's clamp screw ISO 4762			M3	M3	M3	M4
Tightening torque	(Nm)	R	2	2	2	4.5
Approx. weight	(kg)		0.4	0.7	1.2	2.8
Approx. moment of inertia at D max.(10 ⁻³ Kgm ²)		J _{ges}	0.2	0.8	1.4	6.2
Torsional stiffness (10 ⁻³ Nm/rad)			31	72	141	157
Lateral ± max. (mm)			0.2	0.2	0.2	0.25

*Maximum transmittable torque of the clamping hub depends on the bore diameter / see table on page 96

ORDERING EXAMPLE	SL2 SK2	60	W	30	20	80	40-100	XX
Model	●							Special designation only (e.g. special bore / keyway dimensions).
Size		●						
Function system			●					
Bore D1 H7				●				
Bore D2 H7					●			
Disengagement torque Nm						●		
Torque adjustment range Nm							●	

For custom features place an XX at the end of the part number and describe the special requirements (e.g. SL2/60/W/30/20/80/40-100; XX=special dual keyway)

SAFETY COUPLINGS
SK | ES | SL

SK3

WITH CONICAL CLAMPING BUSHING

5 - 2,800 Nm



ABOUT

MATERIAL

- ▶ **Bellows:** high grade stainless steel
- ▶ **Clutch system:** hardened steel
- ▶ **Clamping hubs / bushings:** steel

DESIGN

Two conical clamping assemblies with six tightening screws each, plus jack screws for removal. Clutch system: spring loaded ball-detent principle.

Operable temperature range from -30 to +100° C.

AVAILABLE FUNCTION SYSTEMS

- ▶ **W** = Single position / automatic re-engagement (standard)
- ▶ **D** = Multi-position / automatic re-engagement
- ▶ **G** = Load holding / load blocking
- ▶ **F** = Full disengagement / manual re-engagement

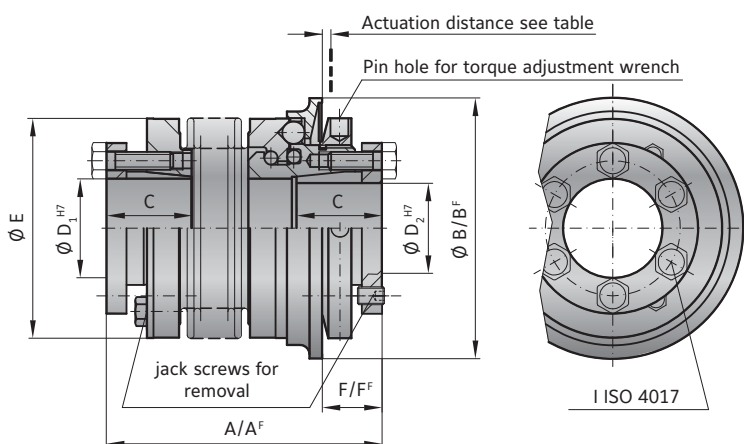

MODEL SK3

SIZE		15	30	60	150	200	300	500	800	1500	2500							
Adjustment range available from (approx. values) (Nm)	T _{KN}	5-10 or 8-20	10-25 or 20-40	10-30 or 25-80	20-70 45-150 80-200	30-90 60-160 140-280	100-200 150-240 220-400	80-200 200-350 300-500	400-650 500-800 600-900	650-850 700-1200 1000-1800	1500-2000 2000-2500 2300-2800							
Adjustment range available from (approx. values) ("F" Version) (Nm)	T _{KN}	7-15	8-20 or 16-30	20-40 or 30-60	20-60 40-80 80-150	80-140 or 130-200	120-180 or 160-300	60-150 100-300 250-500	200-400 or 450-800	1000-1250 or 1250-1500	1400-2200 or 1800-2700							
Overall length ±2 (mm)	A	62	69	72	80	84	94	93	105	99	111	114	128	123	136	151	175	246
Overall length ("F" Version) ±2 (mm)	A ^F	62	69	72	80	84	94	93	105	102	114	117	131	127	140	151	184	252
Actuation ring Ø (mm)	B	55	65	73	92	99	111	120	135	152	174	243						
Actuation ring Ø ("F" Version) (mm)	B ^F	62	70	83	98	117	132	155	177	187	258							
Clamping fit length (mm)	C	19	22	27	32	32	41	41	49	61	80							
Inside diameter from Ø to Ø H7 (mm)	D ₁ /D ₂	10-22	12-23	12-29	15-37	20-44	25-56	25-60	30-60	35-70	50-100							
Outside diameter of coupling (mm)	E	49	55	66	81	90	110	123	133	157	200							
Distance (mm)	F	13	16	18	19	19	23	25	31	30	34							
Distance ("F" Version) (mm)	F ^F	13	14	17	18	17	20	22	20	26	31							
6x Screw ISO 4017	I	M4	M5	M5	M6	M6	M8	M8	M10	M12	M16							
Tightening torque (Nm)	I	4	6	8	12	14	18	25	40	70	120							
Approx. weight (kg)		0.3	0.4	1.2	2.3	3.0	5.0	6.5	9.0	16.3	35							
Moment of inertia (10 ⁻³ kgm ²)	J _{ges}	0.10	0.15	0.28	0.30	0.75	0.80	1.90	2.00	2.80	3.00	5.50	6.00	11.0	12.8	20	42	257
Torsional stiffness (10 ³ Nm/rad)	C _T	20	15	39	28	76	55	175	110	191	140	420	350	510	500	780	1304	3400
Lateral	C _T	0.15	0.20	0.20	0.25	0.20	0.25	0.20	0.25	0.25	0.30	0.25	0.30	0.30	0.35	0.35	0.35	0.35
Angular	C _T	1	1.5	1	1.5	1	1.5	1	1.5	1.5	2	1.5	2	2	2.5	2.5	2.5	2.5
Lateral spring stiffness	C _T	475	137	900	270	1200	380	1550	435	2040	610	3750	1050	2500	840	2000	3600	6070
Actuation distance		1.5	1.5	1.7	1.9	2.2	2.2	2.2	2.2	2.2	3	3						

A^F. B^F. L^F = Full disengagement / manual re-engagement version (F)

Larger versions available upon request.

ORDERING EXAMPLE	SK3 SK5	60	84	D	16	19.05	25	10-30	XX
Model	●								
Size		●							
Overall length mm			●						
Function system				●					
Bore D1 H7					●				
Bore D2 H7						●			
Disengagement torque Nm							●		
Torque adjustment range Nm								●	

Special designation only (e.g. special bore / keyway dimensions).

For custom features place an XX at the end of the part number and describe the special requirements (e.g. SK3/60/84/D/16/19.05/25/10-30/XX; XX=special 30 deg re-engagement angle)

ABOUT



MATERIAL

- ▶ **Bellows:** high grade stainless steel
- ▶ **Clutch system:** hardened steel
- ▶ **Clamping hubs:** up to size 80 aluminum, size 150 and up steel
- ▶ **Tapered male segment:** high strength plastic

DESIGN

Two clamping hubs with one clamping screw each, and one of the clamping hubs with tapered male segment

for plug-in installation. Clutch system: spring loaded ball-detent principle. Operable temperature range from -30 to +100° C.

AVAILABLE FUNCTION SYSTEMS

- ▶ **W** = Single position / automatic re-engagement (standard)
- ▶ **D** = Multi-position / automatic re-engagement
- ▶ **G** = Load holding / load blocking
- ▶ **F** = Full disengagement / manual re-engagement

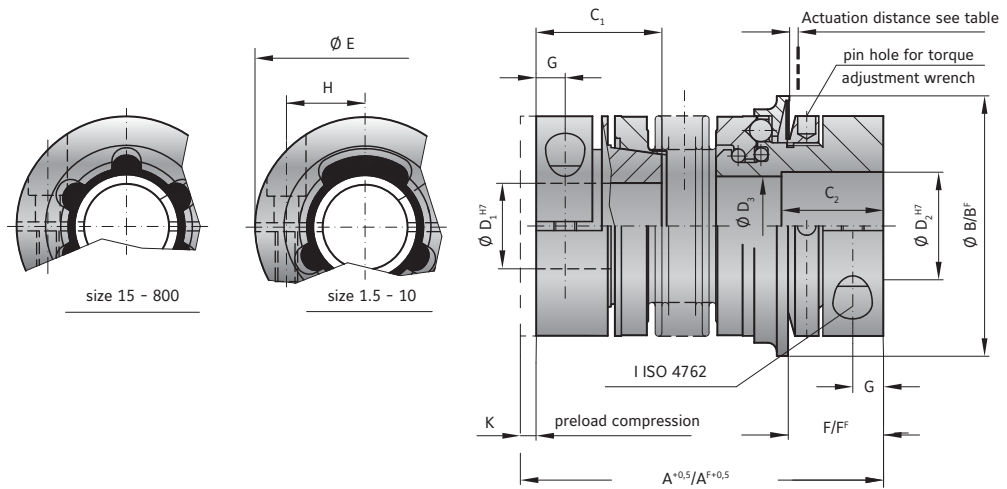

MODEL SK5

Size		1.5	2	4.5	10	15	30	60	80	150	300	500	800
Adjustment range available from - to (approx. values) (Nm)	T_{KN}	0.1-0.6 0.4-1 0.8-1.5	0.2-1.5 or 0.5-2	1-3 or 3-6	2-6 or 4-12	5-10 or 8-20	10-25 or 20-40	10-30 or 25-80	20-70 or 30-90	20-70 or 45-150	100-200 150-240 200-320	80-200 200-350 300-500	400-650 500-800 650-850
Adjustment range available from - to (approx. values) ("F" Version) (Nm)	T_{KN}	0.3-0.8 or 0.6-1.3	0.5-2	2.5-4.5	2-5 or 5-10	7-15	8-20 or 16-30	20-40 or 30-60	20-60 or 40-80	80-150	120-200 or 160-300	60-150 100-300 250-500	200-400 or 450-800
Overall length +0.5 (mm)	A	44	48 54	60 68	70 79	76 83	89 97	105 115	115 127	116 128	143 157	166 180	196
Overall length +0.5 ("F" Version) (mm)	A ^F	44	48 54	60 68	70 79	76 83	89 97	105 115	117 129	118 130	146 160	170 184	207
Actuation ring Ø (mm)	B	23	29	35	45	55	65	73	92	92	120	135	152
Actuation ring Ø ("F" Version) (mm)	B ^F	24	32	42	51.5	62	70	83	98	98	132	155	177
Clamping fit length C ₁ /C ₂ (mm)	C ₁ /C ₂	14 11	16 13	19 16	21 16	28 22	33 27	39 31	43 35	43 35	52 42	61 52	74 48
Bore Diameter from Ø to Ø H7 (mm)	D ₁	3-8	4-12	5-16	5-20	8-22	10-25	12-32	14-38	14-38	30-56	35-60	40-62
Bore Diameter from Ø to Ø H7 (mm)	D ₂	3-8	4-12	5-14	5-20	8-26	10-30	12-32	14-42	14-42	30-60	35-60	40-75
Diameter (mm)	D ₃	9.1	12.1	14.1	20.1	21.1	24.1	32.1	36.1	36.1	58.1	60.1	60.1
Outside diameter (mm)	E	19	25	32	40	49	55	66	81	81	110	123	134
Distance (mm)	F	12	13	15	17	19	24	28	31	31	35	45	50
Distance ("F" Version) (mm)	F ^F	11.5	12	14	16	19	22	29	31	30	36	43	54
Distance (mm)	G	3.5	4	5	5	6.5	7.5	9.5	11	11	13	17	18
Distance between centers (mm)	H	6	8	10	15	17	19	23	27	27	39	41	2x48
Screw ISO 4762	I	M2.5	M3	M4	M4	M5	M6	M8	M10	M10	M12	M16	2xM16
Tightening torque (Nm)	I	1	2	4	4.5	8	15	40	50	70	130	200	250
Pretensioning, approx (mm)	K	0.1-0.5	0.2-0.7	0.2-0.7	0.2-1.0	0.2-1.0	0.5-1.0	0.5-1.0	0.5-1.0	0.5-1.0	0.5-1.5	0.5-2.0	0.5-2.0
Axial recovery of coupling max. (N)	K	4	8 5	15 10	25 30	20 12	50 30	70 45	48 32	82 52	157 106	140 96	200
Approx. weight (kg)		0.038	0.07	0.2	0.3	0.4	0.6	1.4	2	2.4	5.9	9.6	15
Moment of inertia (10 ⁻³ kgm ²)	J _{ges}	0.01	0.01 0.01	0.02 0.02	0.06 0.07	0.10 0.15	0.27 0.32	0.75 0.80	1.80 1.90	2.50 2.80	6.50 7.00	13.0 17.0	50
Torsional stiffness (10 ³ Nm/rad)	C _T	0.7	1.2 1.3	7 5	8 7	12 10	18 16	40 31	68 45	90 60	220 190	260 250	390
Lateral ± (mm)	max. values	0.15	0.15 0.20	0.20 0.25	0.20 0.30	0.15 0.20	0.20 0.25	0.20 0.25	0.20 0.25	0.20 0.25	0.25 0.30	0.30 0.35	0.35
Angular ± (Degree)	max. values	1	1 1.5	1.5 2	1.5 2	1 1.5	1 1.5	1 1.5	1 1.5	1 1.5	1.5 2	2 2.5	2.5
Lateral spring stiffness (N/mm)		70	40 30	290 45	280 145	475 137	900 270	1200 420	920 290	1550 435	3750 1050	2500 840	2000
Actuation distance (mm)		0.7	0.8	0.8	1.2	1.5	1.5	1.7	1.9	1.9	2.2	2.2	2.2

A^F, B^F, L^F = Full disengagement / manual re-engagement version (F)

PRESS FIT ELASTOMER WITH CLAMPING HUB

1 - 1,800 Nm



ABOUT

MATERIAL

- ▶ **Clutch system:** hardened steel
- ▶ **Hub D1:** up to size 450 high strength aluminum, size 800 and up steel
- ▶ **Hub D2:** up to size 60 high strength aluminum, size 150 and up steel
- ▶ **Elastomer insert:** wear resistant thermally stable TPU

ORDERING EXAMPLE
see page 105

DESIGN

Two clamping hubs with one clamping

screw in each and concave driving jaws. Backlash free, vibration damping, electrically isolating elastomer insert press fit into the jaw sets. Clutch system: spring loaded ball-detent principle.

AVAILABLE FUNCTION SYSTEMS

- ▶ **W** = Single position / automatic re-engagement (standard)
- ▶ **D** = Multi-position / automatic re-engagement
- ▶ **G** = Load holding / load blocking
- ▶ **F** = Full disengagement / manual re-engagement

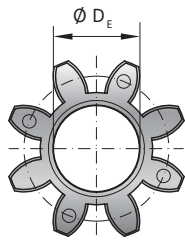

Size 5-800
elastomer insert
type A / B

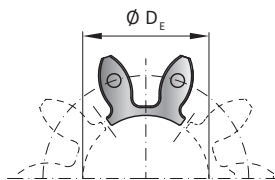

Size 1500
includes 5x elastomer
segments type A / B

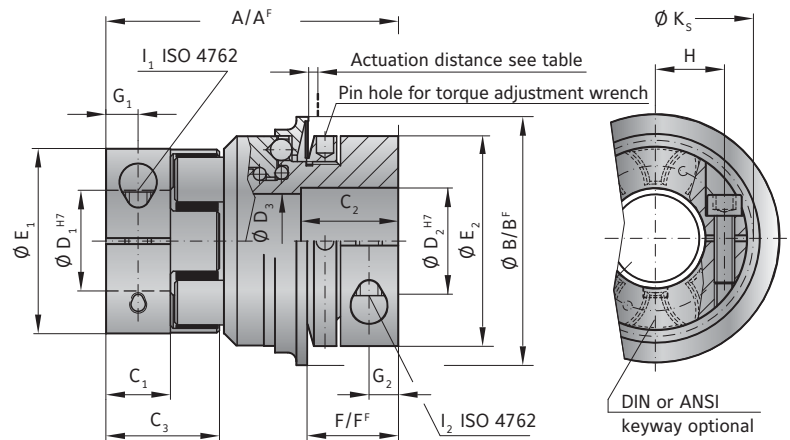

MODEL ES2

Size	5		10		20		60		150		300		450		800		1500		
	A	B	A	B	A	B	A	B	A	B	A	B	A	B	A	B	A	B	
Type (Elastomer insert)																			
Rated torque (Nm)	T_{KN}	9	12	12.5	16	17	21	60	75	160	200	325	405	530	660	950	1100	1950	2450
Max. torque* (Nm)	T_{Kmax}	18	24	25	32	34	42	120	150	320	400	650	810	1060	1350	1900	2150	3900	4900
Adjustment range possible from -to (Nm)	T_{KN}	1-3 or 3-6		2-6 or 4-12		10-25 or 20-40		10-30 or 25-80		20-70 45-150 80-180		100-200 150-240 200-320		80-200 200-350 300-500		400-650 500-800 600-900		600-850 700-1200 1000-1800	
Adjustment range ("F" Version) possible from -to (Nm)	T_{KN}^F	2.5 - 4.5		2-5 or 5-10		8-20 or 16-30		20-40 or 30-60		20-60 40-80 80-150		120-180 or 180-300		60-150 100-300 250-500		200-400 or 450-800		1000-1250 or 1250-1500	
Overall length (mm)	A	50		60		86		96		106		140		164		179		245	
Overall length ("F" Version) (mm)	A_F	50		60		86		96		108		143		168		190		257	
Actuation ring \varnothing (mm)	B	35		45		65		73		92		120		135		152		174	
Outside diameter of actuation ring ("F" Version) (mm)	B_F	42		51.5		70		83		98		132		155		177		187	
Clamping fit length (mm)	C_1	8		10.3		17		20		21		31		34		46		88	
Fit length (mm)	C_2	14		16		27		31		35		42		51		45		86	
Length of hub (mm)	C_3	16.7		20.7		31		36		39		52		57		74		120	
Inside diameter from \varnothing to \varnothing H7 (mm)	D_1	4 - 12.7		5 - 16		8 - 25		12 - 32		19 - 36		20 - 45		28 - 60		35 - 80		35 - 90	
Inside diameter from \varnothing to \varnothing H7 (mm)	D_2	6 - 14		6 - 20		12 - 30		15 - 32		19 - 42		30 - 60		35 - 60		40 - 75		50 - 80	
Diameter \varnothing (mm)	D_3	14.1		20.1		24.1		32.1		36.1		58.1		60.1		60.1		68.1	
Inside diameter (Elastomer insert) (mm)	D_E	10.2		14.2		19.2		26.2		29.2		36.2		46.2		60.5		79	
Diameter of the hub (mm)	E_1	25		32		42		56		66.5		82		102		136.5		160	
Diameter of the hub (mm)	E_2	19		40		55		66		81		110		123		132		157	
Distance (mm)	F	15		17		24		28		31		35		45		50		63	
Distance ("F" Version) (mm)	F_F	14		16		22		29		30		35		43		54		61	
Distance (mm)	G_1	4		5		8.5		10		11		15		17.5		23		36	
Distance (mm)	G_2	5		5		7.5		9.5		11		13		17		18		22.5	
Distance between centers (mm)	H_1	8		10.5		15		21		24		29		38		50.5		2x 57	
Screws (ISO 4762)		M3		M4		M5		M6		M8		M10		M12		M16		2x M16	
Tightening torque (Nm)	I_1	2		4.5		8		15		35		70		120		290		300	
Distance between centers D2 side (mm)	H_2	10		15		19		23		27		39		41		48		2x 55	
Screws (ISO 4762)		M4		M4		M6		M8		M10		M12		M16		2x M16		2x M20	
Tightening torque (Nm)	I_2	4		4.5		15		40		70		130		200		250		470	
Diameter with screwhead (mm)	K_S	25		32		44.5		57		68		85		105		139		155	
Approx. weight (kg)		0.2		0.3		0.6		1.0		2.4		5.8		9.3		14.3		26	
Moment of inertia (10^{-3} kgm ²)	J_{ges}	0.02		0.06		0.25		0.7		2.3		11		22		33.5		185	
Actuation distance (mm)		0.8		1.2		1.5		1.7		1.9		2.2		2.2		2.2		3.0	

For information on shaft misalignment, torsional stiffness, and other details about the elastomer inserts see page 105. A^F, B^F, L^F = Full disengagement / manual re-engagement version (F)
* Maximum transmittable torque of the clamping hub depends on the bore diameter see table on page 105.

ABOUT



DESIGN

Clamping collar with clamping screw.
Clamping hub with concave driving jaws and clamping screw. Backlash free, vibration damping, electrically isolating elastomer insert press fit into the jaw sets. Clutch system: spring loaded ball-detent principle, in a special compact, low inertia design.

AVAILABLE FUNCTION SYSTEMS

- ▶ W = Single position / automatic re-engagement (standard)
- ▶ D = Multi-position / automatic re-engagement

ORDERING EXAMPLE

see page 105

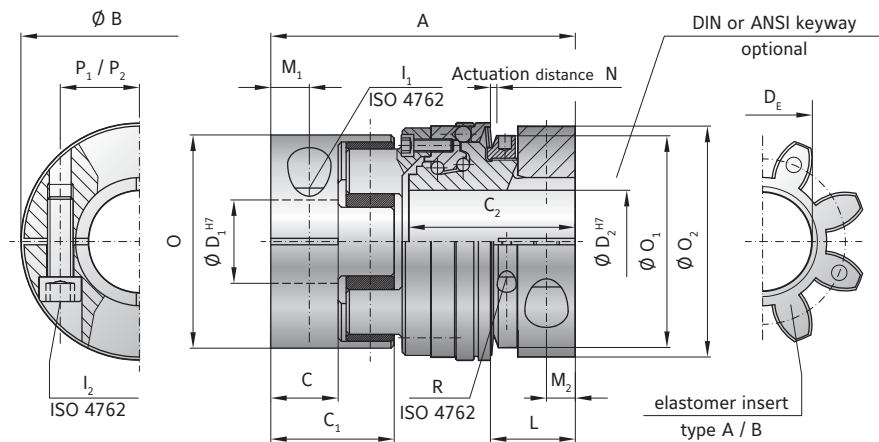

MODEL SLE

SIZE		30		60		150		300		
Type (elastomer insert)		A	B	A	B	A	B	A	B	
Rated torque	T_{KN}	60	75	160	200	325	405	530	660	
Max. torque	$T_{KN max}$	120	150	320	400	650	810	1060	1350	
Adjustment range* possible from -to	(Nm) T_{KN}	10-35 30-80 40-135		30-80 60-120 100-200		40-100 100-200 150-300		200-350 300-450 400-550 550-700		
Overall length	(mm)	A	85	93	122	135				
Actuation ring diameter	(mm)	B	63	74	92	118				
Hub length (coupling hub end)	(mm)	C/C ₁	20 / 36	21 / 39	31 / 52	34 / 57				
Length of hub (torque limiting portion)		C ₂	45	53	63	72				
Bore diameter from Ø to Ø H7	(mm)	D ₁ /D ₂	12-32 / 12-30	16-36 / 16-35	19-45 / 19-48	22-60 / 22-60				
Inner diameter (elastomer insert)		D _E	26.2	29.2	36.2	46.2				
ISO 4762 screw, coupling side / torque limiter side			M6	M8	M10	M12				
Tightening torque	(Nm)	I ₁ /I ₂	15	40	75	130				
Distance to actuation ring edge	(mm)	L	22	26	32	35				
Distance	(mm)	M ₁ /M ₂	10 / 7.5	12 / 9	15 / 11	17.5 / 12				
Actuation distance	(mm)	N	1.3	1.5	1.8	2				
Clamping hub Ø, elastomer coupling		O	56	66.5	82	102				
Ø Adjustment nut		O ₁	55	66	82	100				
Clamping hub Ø, safety coupling		O ₂	59	72	90	112				
Distance to clamping screw, coupling side / torque limiter side		P ₁ /P ₂	21 / 21.5	24 / 25	29 / 33	38 / 41				
Adjustment nut's clamp screw ISO 4762			M3	M3	M3	M4				
Tightening torque	(Nm)	R	2	2	2	4.5				
Approx. weight	(kg)		0.4	0.8	1.5	2.9				
Approx. moment of inertia at D max.(10 ⁻³ Kgm ²)		J _{ges}	0.3	1	1.8	5				
Static torsional rigidity	(Nm/rad)		3290	9750	4970	10600	12400	18000	15100	27000
Dynamic torsional rigidity	(Nm/rad)		7940	11900	13400	29300	23700	40400	55400	81200
Lateral ±	approx. (mm)		0.12	0.1	0.15	0.12	0.18	0.14	0.2	0.18

ESL

WITH KEYWAY MOUNTING

1 - 150 Nm



ABOUT

MATERIAL

- ▶ **Clutch system:** high strength steel, drive balls made from hardened steel
- ▶ **Hubs:** high strength aluminum
- ▶ **Elastomer insert:** wear resistant, thermally stable TPU

elastomer insert press fit into the jaw sets. The clutch system is integrated into one of the hubs. All couplings have a multi-position function system due to the spring loaded, interlocking ball system.

DESIGN

Two hubs, each with keyway, set screw, and concave driving jaws. Backlash free, vibration damping, electrically isolating

DISENGAGEMENT SPEED

Negligible wear at up to 200 rpm. Contact R+W for higher speed applications.

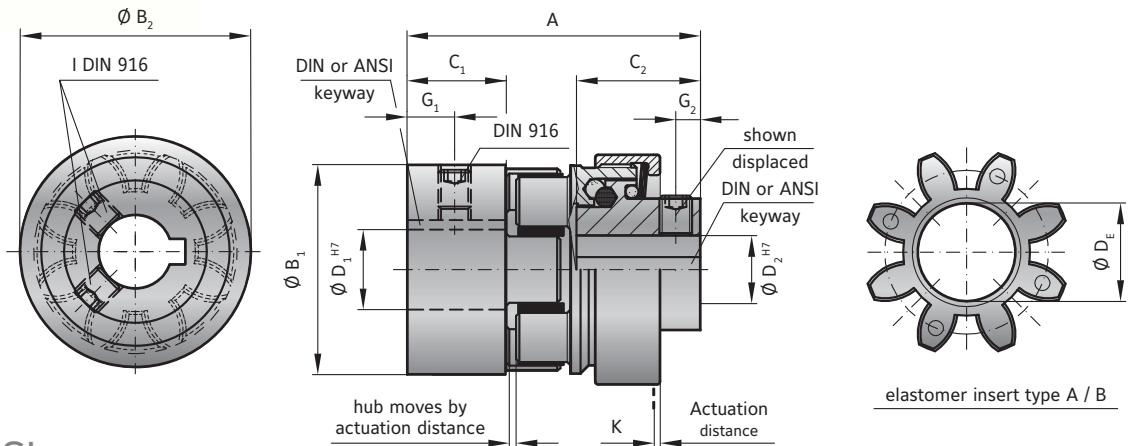

MODEL ESL

Size			5		10		20		60		150	
Type (Elastomer insert)			A	B	A	B	A	B	A	B	A	B
Rated torque (Nm)	T_{kn}		9	12	12.5	16	17	21	60	75	160	200
Torque setting possible* from - to (Nm)	T_{kn}		1-6		1-12		3-19		5-60		20-150	
Overall length (mm)	A		34		45		64		80		90	
Diameter of the hub (mm)	B_1		25		32		42		56		66.5	
Diameter of the hub (mm)	B_2		29		32		46		59		75	
Clamping fit length (mm)	C_1		12.5		12		25		30		35	
Clamping fit length (mm)	C_2		11.5		20		22		31		35	
Inside diameter from \emptyset to \emptyset H7 (mm)	D_1		6-15		6-18		8-25		12-32		19-38	
Inside diameter from \emptyset to \emptyset H7 (mm)	D_2		6-10		6-12		8-19		12-24		19-32	
Inside diameter max. (elastomer) (mm)	D_E		10.5		14.2		19.2		26.2		29.2	
Distance (mm)	G_1		5		6		9		11		12	
Distance (mm)	G_2		2.5		3.5		4		4		4	
Screws DIN 916**	I		depending on bore diameter see below table									
Approx. weight (kg)			0.05		0.15		0.2		0.5		1	
Moment of inertia (10^{-3} kgm ²)	J_1/J_2		0.01		0.02		0.08		0.15		0.5	
Actuation distance (mm)	K		0.6		0.6		0.7		1.1		1.4	

* Disengagement torque is permanently set at the factory. For information on shaft misalignment, torsional stiffness, and other details about the elastomer inserts see page 105.

ORDERING EXAMPLE	ESL	10	A	14	12	10	XX
Model	●						Special designation only (e.g. special bore tolerance).
Size		●					
Elastomer insert type			●				
Bore D1 H7 includes standard keyway				●			
Bore D2 H7 includes standard keyway					●		
Disengagement torque Nm (not adjustable)						●	
For custom features place an XX at the end of the part number and describe the special requirements (e.g. ESL/10/A/14/12/10/XX; XX=stainless steel)							

FIXED DISENGAGEMENT TORQUE

The ESL coupling is unlike other R+W safety couplings in that the disengagement torque is permanently set and tamper proof.

** SET SCREWS

D1/D2	- \emptyset 10	\emptyset 11-12	\emptyset 13-30	\emptyset 31-58	\emptyset 59-80
I	M3	M4	M5	M8	M10

Bores <6mm made without keyway.

DESCRIPTION OF THE ELASTOMER TYPES

Design	Shore hardness	Color	Material	Relative damping (μ)	Temperature range	Features
A	98 Sh A	red	TPU	0.4 - 0.5	-30°C to +100°C	high damping
B	64 Sh D	green	TPU	0.3 - 0.45	-30°C to +120°C	high torsional stiffness
D	65 Sh D	black	TPU	0.3 - 0.45	-10°C to + 70°C	electrically conductive

The values of the relative damping were determined at 10 Hz and +20° C.

ES2 | ESL

SIZE		5		10		20		60		150		300		450		800		1500	
Elastomer type		A	B	A	B	A	B	A	B	A	B	A	B	A	B	A	B	A	B
Static torsional stiffness (Nm/rad)	C_T	150	350	260	600	1140	2500	3290	9750	4970	10600	12400	18000	15100	27000	41300	66080	87600	109000
Dynamic torsional stiffness (Nm/rad)	C_{Tdyn}	300	700	541	1650	2540	4440	7940	11900	13400	29300	23700	40400	55400	81200	82600	180150	17500	216000
Lateral \pm (mm)	Max. values	0.08	0.06	0.1	0.08	0.1	0.08	0.12	0.1	0.15	0.12	0.18	0.14	0.2	0.18	0.25	0.2	0.5	0.3
Angular \pm (Degree)		1	0.8	1	0.8	1	0.8	1	0.8	1	0.8	1	0.8	1	0.8	1	0.8	1.5	1
Axial \pm (mm)		± 1	± 1	± 2	± 2	± 2	± 2	± 2	± 2	± 2	± 2	± 2	± 2	± 2	± 2	± 2	± 2	± 2	± 2

Static torsional stiffness at 50% T_{KN}

Dynamic torsional stiffness at T_{KN}

SLE

SIZE		30		60		150		300	
Elastomer type		A	B	A	B	A	B	A	B
Static torsional stiffness (Nm/rad)	C_T	3290	9750	4970	10600	12400	18000	15100	27000
Dynamic torsional stiffness (Nm/rad)	C_{Tdyn}	7940	11900	13400	29300	23700	40400	55400	81200
Lateral \pm (mm)	Max. values	0.12	0.1	0.15	0.12	0.18	0.14	0.2	0.18
Angular \pm (Degree)		1	0.8	1	0.8	1	0.8	1	0.8
Axial \pm (mm)		± 2	± 2	± 2	± 2	± 2	± 2	± 2	± 2

Static torsional stiffness at 50% T_{KN}

Dynamic torsional stiffness at T_{KN}

ES2 | MAXIMUM TRANSMITTABLE TORQUE (Nm) OF THE CLAMPING HUB DEPENDS ON THE BORE DIAMETER (mm)

Size	Ø 4	Ø 5	Ø 8	Ø 16	Ø 19	Ø 25	Ø 30	Ø 32	Ø 35	Ø 45	Ø 50	Ø 55	Ø 60	Ø 65	Ø 70	Ø 75	Ø 80	Ø 85	Ø 90
5	1.5	2	8																
10		4	12	32															
20			20	35	45	60													
60				50	80	100	110	120											
150					120	160	180	200	220										
300					200	230	300	350	380	420									
450							420	480	510	600	660	750	850						
800									700	750	800	835	865	900	925	950	1,000		
1500									1,900	2,600	2,900	3,200	35,00	3,800	4,000	4,300	4,600	4,900	5,200

Higher torque possible with keyways

SLE | MAXIMUM TRANSMITTABLE TORQUE (Nm) OF THE CLAMPING HUB DEPENDS ON THE BORE DIAMETER (mm)

Size	Ø 12	Ø 15	Ø 20	Ø 25	Ø 30	Ø 35	Ø 40	Ø 45	Ø 50	Ø 55	Ø 60
30	30	55	80	110	130						
60		80	120	160	200	220					
150			200	250	300	350	400	450			
300				350	430	510	590	670	750	830	910

ORDERING EXAMPLE	SLE ES2	60	A	W	30	19.05	80	40-100	XX
Model	●								Special designation only (e.g. special bore tolerance).
Size		●							
Elastomer insert type			●						
Function system				●					
Bore D1 H7					●				
Bore D2 H7						●			
Disengagement torque Nm							●		
Torque adjustment range Nm								●	

For custom features place an XX at the end of the part number and describe the special requirements (e.g. SLE/60/A/W/30/19.05/80/40-100/XX; XX=anodized aluminum)

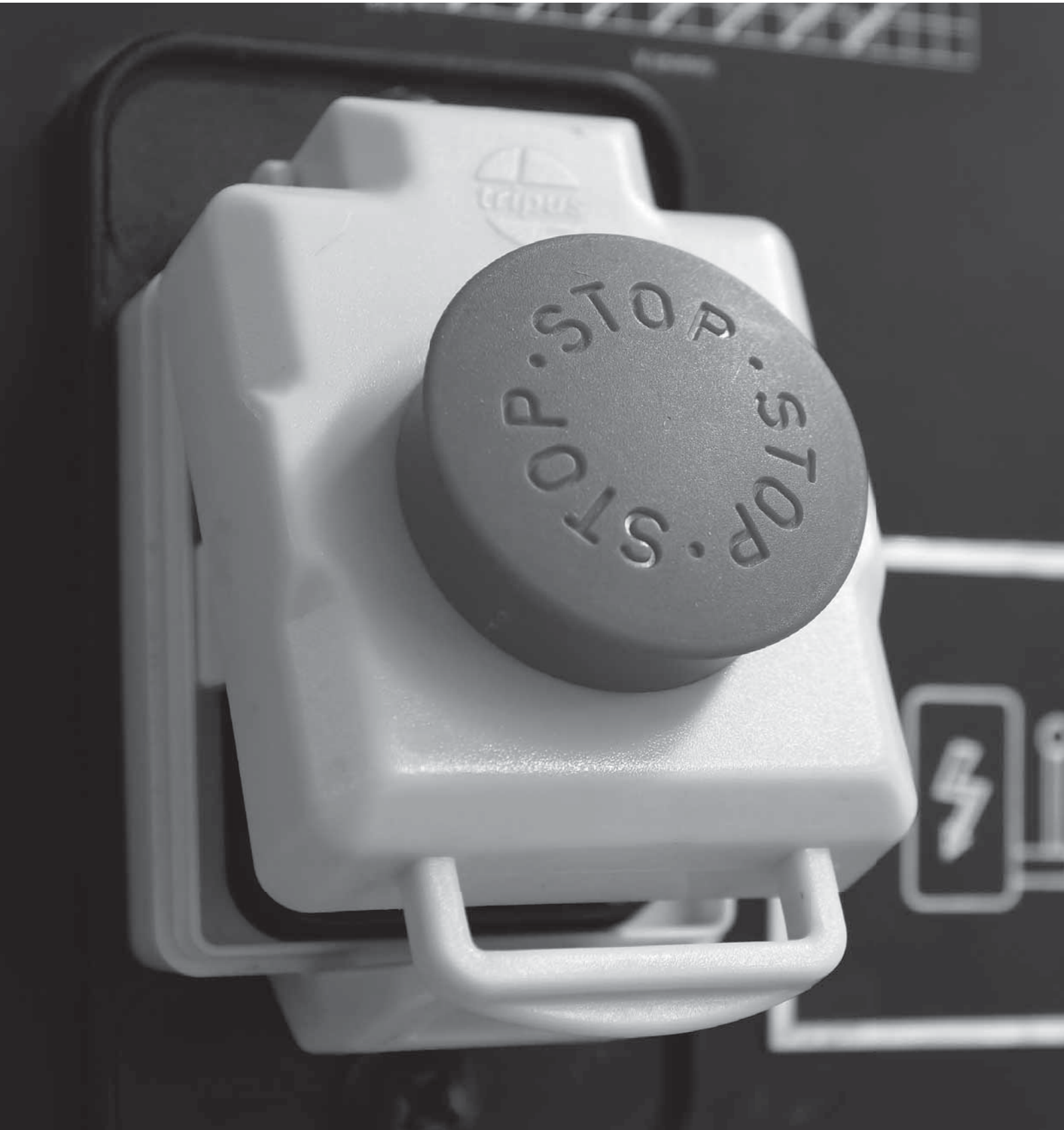

SAFETY COUPLING ACCESSORIES

ACCESSORIES FOR SK / ES2 / SL SAFETY COUPLINGS

It is important that switches be 100% tested for proper functioning after mounting with safety coupling.

PROXIMITY SWITCH (E-STOP FUNCTION)

SK

ES2

ORDER NUMBER 650.2703.001

TECHNICAL DATA	SK, ES2
Voltage	10 to 30 V DC
Max. output current	200 mA
Max. switch frequency	800 KHz
Temperature range	-25° to +70° C
Protective system	IP 67
Switch type	normally open
Max. detection gap	max. 2 mm
SWITCH DIAGRAM SK, ES2	

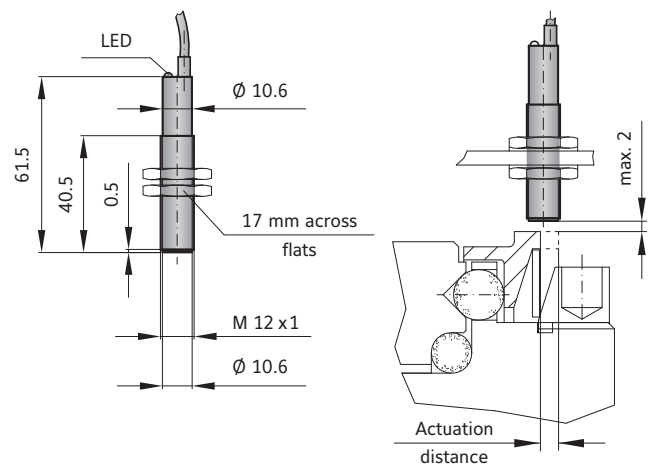

SL

ORDER NUMBER 619.4711.650

TECHNICAL DATA	SL
Voltage	10 to 30 V DC
Max. output current	200 mA
Max. switch frequency	≤ 3 KHz
Temperature range	-25° to +70° C
Protective system	IP 67
Switch type	PNP, NO
Max. detection gap	max. 2 mm
SWITCH DIAGRAM SL	

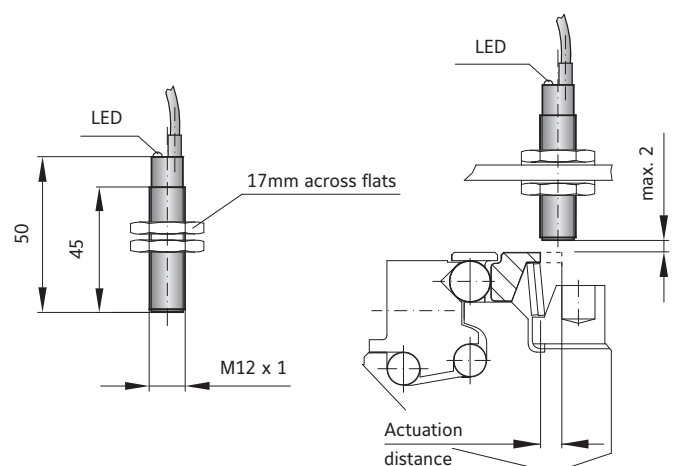

It is important that switches be 100% tested for proper functioning after mounting with safety coupling.

MECHANICAL LIMIT SWITCH (E-STOP FUNCTION)

SK

ES

SL

ORDER NUMBER 618.6740.644

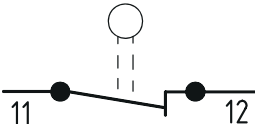
TECHNICAL DATA	SK, ES2, SL
Max. voltage	250 V AC
MAX. CONSTANT CURRENT:	2.5h A
Protective system	IP 65
Contact system	Opener (forced separating)
Temperature range	-30° to +80° C
Actuation	Plunger (metal)
SWITCH DIAGRAM SK, ES2, SL	
	

The mechanical limit switch is suitable for size 30 and up. For smaller safety couplings the proximity sensor is recommended.

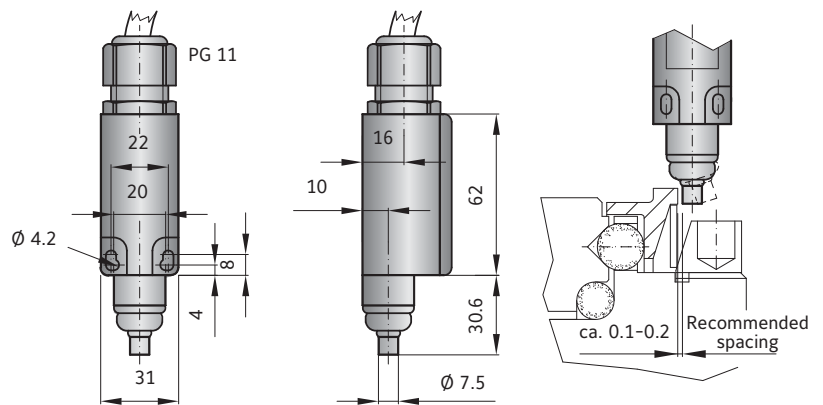

The switch plunger (pictured above and right) should be located as close to the actuation ring / limit switch plate as possible (approximately 0.1-0.2mm).

ACCESSORIES FOR ATEX SAFETY COUPLINGS

It is important that switches be 100% tested for proper functioning after mounting with safety coupling.

ATEX PROXIMITY SWITCH (E-STOP FUNCTION)

SK **ES2**

ORDER NUMBER EEX. 1624.004

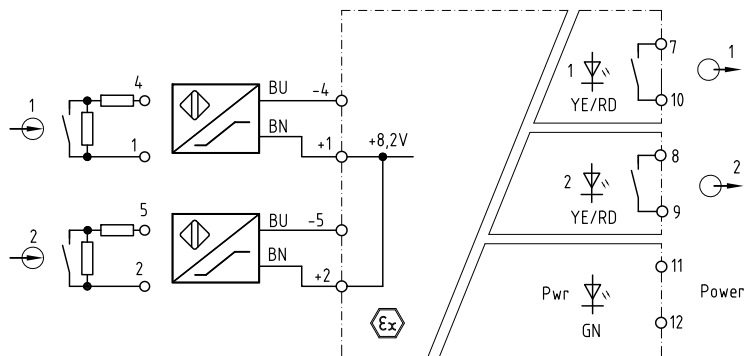
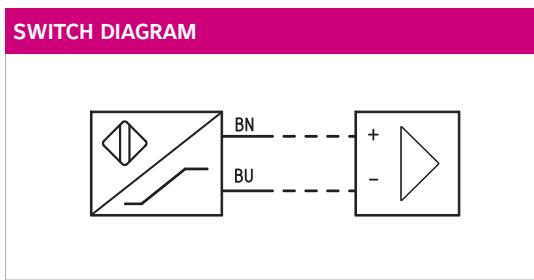
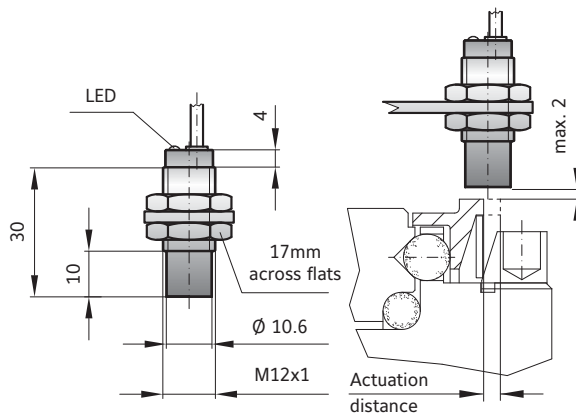
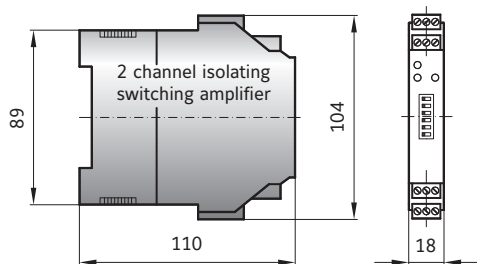

ACCESSORIES FOR SK/ES2/SL SAFETY COUPLINGS

R+W SPANNER WRENCH FOR TORQUE ADJUSTMENT



For smaller couplings the spanner wrench is not necessary. In sizes 1.5/2/4.5/10 the torque adjustment nut is easily turned with a screw or pin.

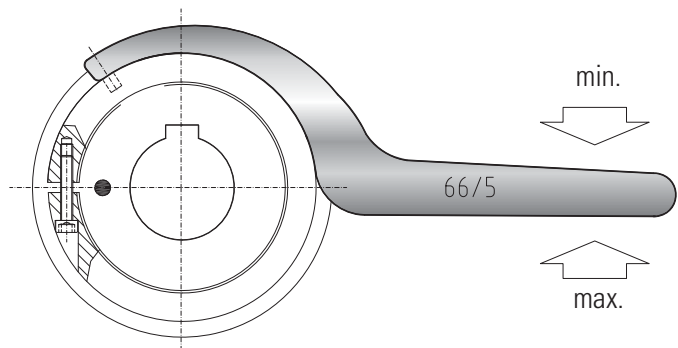

ORDER NUMBERS

COUPLING SIZE	SK Single position Multi-position Load holding	SK Full disengagement	ES2 Single position Multi-position Load holding	ES2 Full disengagement	SL Single position Multi-position
15	49/4	49/4	-	-	-
20	-	-	55/4	55/4	-
30	55/4	55/4	-	-	55/4
60	66/5	66/5	66/5	66/5	66/5
80	82/5	82/5	-	-	-
150	82/5	82/5	82/5	82/5	82/5
200	90/6	98/5	-	-	-
300	114/6	114/6	114/6	114/6	100/6
450	-	-	126/8	126/8	-
500	126/8	126/8	-	-	-
800	134/8	144/8	134/8	144/8	-
1500	163/8	163/8	163/8	163/8	-
2500	210/10	226/10	-	-	-

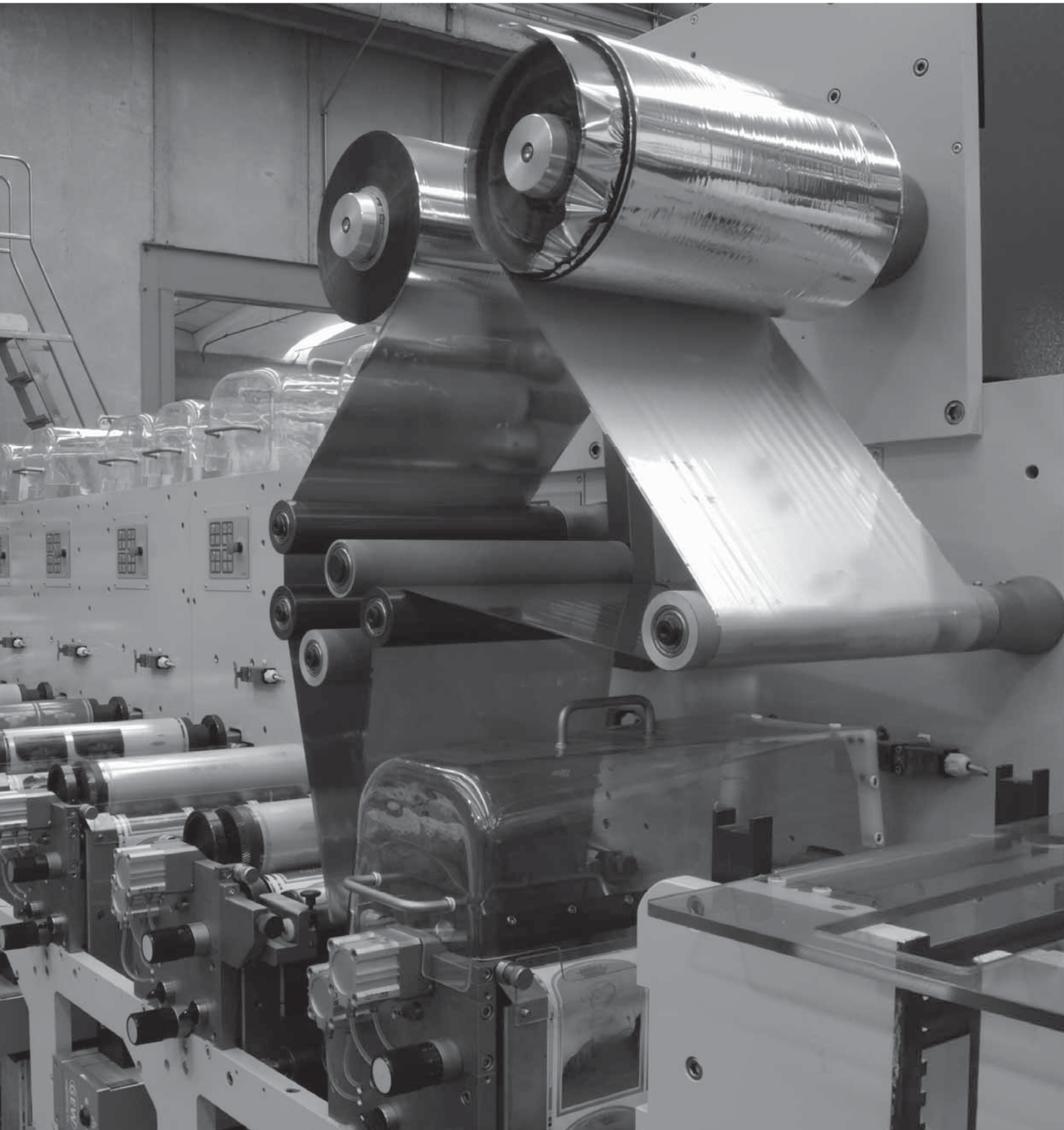



SIZES FROM 10 - 25,000 Nm LINE SHAFT COUPLINGS

GENERAL INFORMATION R+W LINE SHAFT COUPLINGS:



SERVICE LIFE

R+W line shaft couplings are wear and maintenance free for an infinite service life, as long as the technical limits are not exceeded.

FIT CLEARANCE

Overall shaft / hub clearance of 0.01 - 0.05 mm

ROTATIONAL SPEED

After selecting overall length A, contact R+W for maximum speed.

SPECIAL SOLUTIONS

Various materials, tolerances, dimensions and performance ratings available for custom applications on request.

ATEX (Optional)

For use in hazardous zones 1/21 and 2/22, R+W line shaft couplings have been authorized under directive 94/9/EG and is available with certification.







BACKLASH FREE, TORSIONALLY STIFF LINE SHAFT COUPLINGS

SIZES FROM 10 - 4,000 Nm

MODEL

FEATURES

ZA		with clamping hub from 10 - 800 Nm <ul style="list-style-type: none">▶ installation and removal possible without disturbing other machine components▶ standard lengths up to 6 meters▶ no intermediate support bearings required	Page 116
ZA		with conical clamping system from 1,500 - 4,000 Nm <ul style="list-style-type: none">▶ installation and removal possible without disturbing other machine components▶ standard lengths up to 6 meters▶ no intermediate support bearings required	Page 117
ZAE		with fully split clamping hub from 10 - 800 Nm <ul style="list-style-type: none">▶ complete coupling system mounts laterally for very easy installation and removal▶ standard lengths up to 6 meters▶ no intermediate support bearings required	Page 118
ZAL		with fully split clamping hub from 10 - 800 Nm <ul style="list-style-type: none">▶ complete coupling system mounts laterally for very easy installation and removal▶ standard lengths up to 6 meters, with CFK tube▶ no intermediate support bearings required	Page 119



BACKLASH FREE LINE SHAFT COUPLINGS

SIZES FROM 12.5 - 25,000 Nm

MODEL

FEATURES

EZ2



**with fully split clamping hub
from 12.5 - 25,000 Nm**

Pages 120-121

- ▶ standard lengths up to 4 meters
- ▶ no intermediate support bearings required
- ▶ complete coupling system mounts laterally for very easy installation and removal

EZV



**with fully split clamping hub,
adjustable length
from 12.5 - 1,200 Nm**

Pages 122-123

- ▶ adjustable length ranges up to 4 meters
- ▶ no intermediate support bearings required
- ▶ complete coupling system mounts laterally for very easy installation and removal

ZA

WITH CLAMPING HUB

10 - 800 Nm



ABOUT

FEATURES

- ▶ for spanning larger distances between shaft ends
- ▶ standard lengths up to 6 meters
- ▶ no intermediate support bearings required
- ▶ extremely straight and laterally stiff intermediate tube

- ▶ **Intermediate tube:** up to size 150 aluminum, size 300 and up steel, optional CFK
- ▶ **Hubs:** up to size 60 aluminum, size 150 and up steel

MATERIAL

- ▶ **Bellows:** high grade stainless steel

DESIGN

Two clamping hubs with a single clamping screw in each. A special support system carries the weight of the tube on the hubs. Operable temperature range from -30 to +100 °C.

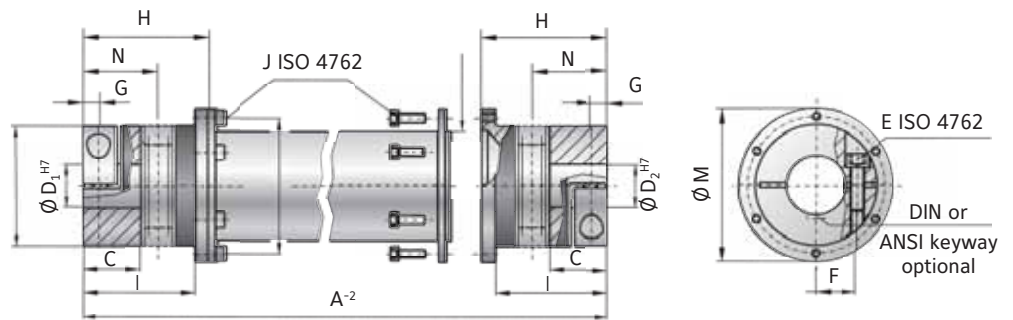

MODEL ZA

SIZE			10	30	60	150	200	300	500	800
Rated torque (Nm)	T_{KN}		10	30	60	150	200	300	500	800
Overall length min. to max. (mm)	A^2		110 - 6000	140 - 6000	170 - 6000	190 - 6000	210 - 6000	250 - 6000	260 - 6000	260 - 6000
Outside diameter clamping hub (mm)	B		40	55	66	81	90	110	123	134
Fit length (mm)	C		16	27	31	35.5	40.5	43	50	48
Inside diameter from \emptyset to \emptyset H7 (mm)	$D_{1/2}$		5 - 20	10 - 28	12 - 32	19 - 42	22 - 45	30 - 60	35 - 60	40 - 72
With keyway max. \emptyset H7 (mm)	$D_{1/2}$		17	23	29	36	45	60	60	66
ISO 4762 clamping screw			M4	M6	M8	M10	M12	M12	M16	2x M16
Tightening torque (Nm)	E		5	15	40	70	110	130	200	250
Distance between centers (mm)	F		15	19	23	27	31	39	41	48
Distance (mm)	G		5	7.5	9.5	11	12.5	13	17	18
Length bellows body (mm)	H		44.5	57.5	71	78	86	94	110	101
Distance (mm)	I		38.5	51	61	69	75.5	81	96	89
ISO 4762 clamping screw			4x M4	6x M4	6x M5	8x M6	8x M6	8x M8	8x M8	10x M8
Tightening torque (Nm)	J		3	4	7	10	12	30	30	40
Outside diameter tube section (mm)	K		35	50	60	76	90	100	110	120
Bolt hole circle \emptyset (mm)	L		45	62.5	71.5	88	100	120	132	138
Outside diameter flange (mm)	M		52	70	80	98	110	135	148	153
Shaft average value (mm)	N		25	34	41	47	52	56	66	64

For maximum misalignment values see page 16.

ORDERING EXAMPLE	ZA	10	1551	18	19.05	XX
Model	●					Special designation only (e.g. special bore tolerance).
Size		●				
Overall length mm			●			
Bore D1 H7				●		
Bore D2 H7					●	
For custom features place an XX at the end of the part number and describe the special requirements (e.g. ZA/10/1551/18/19.05/XX; XX=anodized aluminum)						

ZA

WITH CONICAL CLAMPING SYSTEM

1,500 - 4,000 Nm



ABOUT

FEATURES

- ▶ for spanning larger distances between shaft ends
- ▶ standard lengths up to 6 meters
- ▶ no intermediate support bearings required
- ▶ extremely straight and laterally stiff intermediate tube

MATERIAL

- ▶ **Bellows:** high grade stainless steel

- ▶ **Intermediate tube:** steel, optional CFK
- ▶ **Hubs:** steel

DESIGN

Two conical clamping bushings with separate screws for mounting and dismounting. A special support system carries the weight of the tube on the hubs. Operable temperature range from -30 to +100 °C.

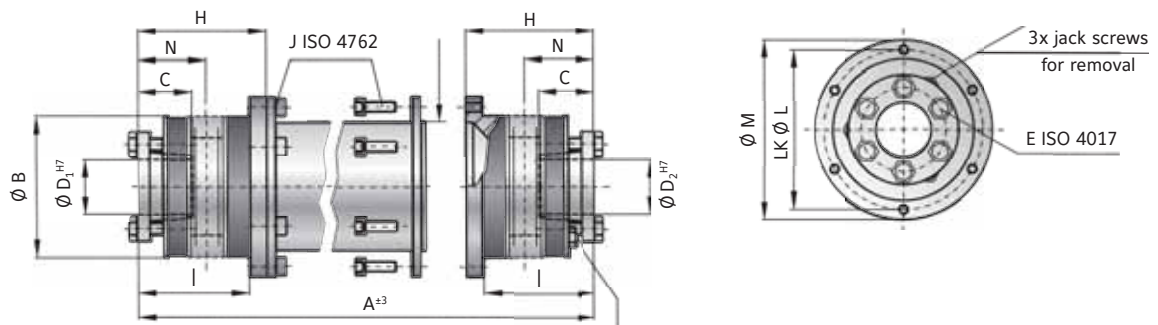

MODEL ZA

SIZE			1500	4000
Rated torque (Nm)	T _{KN}		1500	4000
Overall length min. to max. (mm)	A ^{±3}		280 - 6000	280 - 6000
Outside diameter (mm)	B		157	200
Fit length (mm)	C		61	80.5
Inside diameter from Ø to Ø H7 (mm)	D _{1/2}		35 - 70	40 - 100
ISO 4017 clamping screws	E		6 x M12	6 x M16
Tightening torque (Nm)			70	120
Length bellows body (mm)	H		98	103.5
Distance (mm)	I		82	84
ISO 4762 clamping screws	J		10x M10	12x M12
Tightening torque (Nm)			70	120
Outside diameter tube section (mm)	K		150	160
Bolt hole circle Ø (mm)	L		168	193
Outside diameter flange (mm)	M		184	213
Shaft average value (mm)	N		56	61

For maximum misalignment values see page 16.

ORDERING EXAMPLE	ZA	1500	2551	50.8	70	XX
Model	●					
Size		●				
Overall length mm			●			
Bore D1 H7				●		
Bore D2 H7					●	
For custom features place an XX at the end of the part number and describe the special requirements (e.g. ZA/1500/2551/50.8/70/XX; XX=stainless steel)						

Special designation only (e.g. special bore tolerance).

WITH FULLY SPLIT CLAMPING HUB

10 - 800 Nm



ABOUT

FEATURES

- ▶ for spanning larger distances between shaft ends
- ▶ standard lengths up to 6 meters
- ▶ no intermediate support bearings required
- ▶ extremely straight and laterally stiff intermediate tube

- ▶ **Intermediate tube:** up to size 150 aluminum, size 300 and up steel
- ▶ **Hubs:** up to size 60 aluminum, size 150 and up steel

MATERIAL

- ▶ **Bellows:** high grade stainless steel

DESIGN

Two clamping hubs with two clamping screws in each. A special support system carries the weight of the tube on the hubs. Operable temperature range from -30 to +100 °C.

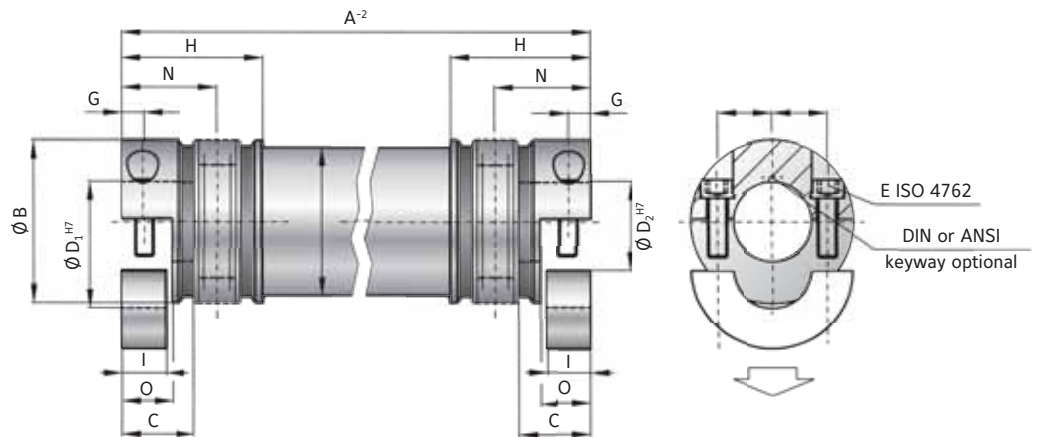

MODEL ZAE

SIZE			10	30	60	150	300	500	800
Rated torque (Nm)	T_{KN}		10	30	60	150	300	500	800
Overall length min. to max. (mm)	A^{-2}		100 - 6000	130 - 6000	160 - 6000	180 - 6000	240 - 6000	250 - 6000	250 - 6000
Outside diameter clamping hub (mm)	B		40	55	66	81	110	123	133
Fit length (mm)	C		16	27	31	34.5	42	50	47
Inside diameter from \emptyset to \emptyset H7 (mm)	$D_{1/2}$		5 - 20	10 - 28	12 - 32	19 - 42	30 - 60	35 - 60	40 - 72
Max. inside diameter clamping hub (mm)	D_{max}		24	30	32	42	60	60	75
With keyway - max \emptyset H7 (mm)	$D_{1/2}$		17	23	29	36	60	60	66
ISO 4762 clamping screws	E		M4	M6	M8	M10	M12	M16	M16
Tightening torque (Nm)			5	15	40	70	130	200	250
Distance between centers (mm)	F		15	19	23	27	39	41	48
Distance (mm)	G		5	7.5	9.5	12	14	17	19
Length bellows body (mm)	H		39.5	52	64	72	83	96	95
Clamping length (mm)	I		10	15	19	22	28	33.5	37.5
Outside diameter tube section (mm)	K		35	50	60	76	100	110	120
Length (mm)	O		11.5	17	21	24	30	35	40
Shaft average value (mm)	N		25	34	41	47	56	66	65

For maximum misalignment values see page 16.

ORDERING EXAMPLE	ZAE	10	1551	18	19.05	XX
Model	●					
Size		●				
Overall length mm			●			
Bore D1 H7				●		
Bore D2 H7					●	
For custom features place an XX at the end of the part number and describe the special requirements (e.g. ZAE/10/1551/18/19.05/XX; XX=anodized aluminum)						

Special designation only (e.g. special bore tolerance).



WITH FULLY SPLIT CLAMPING HUB AND CFK INTERMEDIATE TUBE, 10 - 800 Nm

ABOUT



FEATURES

- ▶ low moment of inertia
- ▶ for spanning larger distances between shaft ends
- ▶ standard lengths up to 6 meters
- ▶ no intermediate support bearings required
- ▶ good for higher speeds

▶ Intermediate tube: CFK

- ▶ Hubs: up to size 60 aluminum, size 150 and up steel

DESIGN

Two clamping hubs with two clamping screws in each. A special support system carries the weight of the tube on the hubs. Operable temperature range from -30 to +100 °C.

MATERIAL

- ▶ Bellows: high grade stainless steel

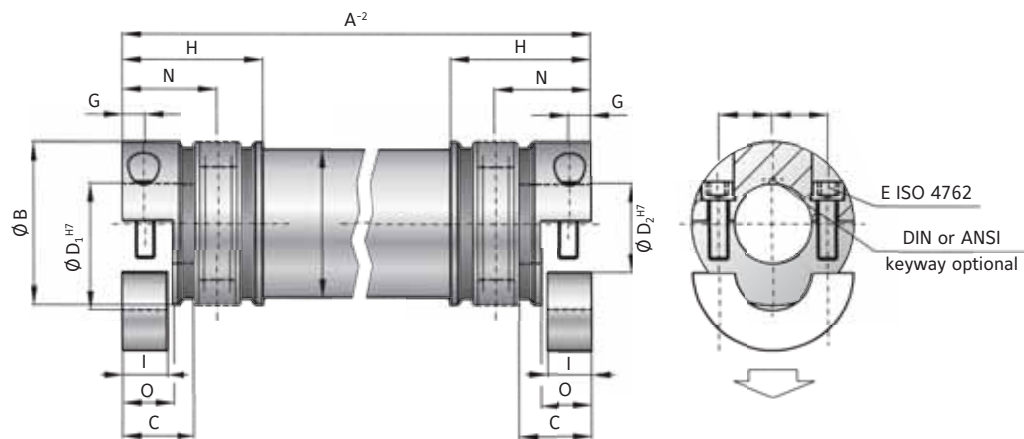

MODEL ZAL

SIZE		10	30	60	150	300	500	800
Rated torque (Nm)	T _{KN}	10	30	60	150	300	500	800
Overall length min. to max. (mm)	A ⁻²	100 - 6000	130 - 6000	160 - 6000	180 - 6000	240 - 6000	250 - 6000	250 - 6000
Outside diameter clamping hub (mm)	B	40	55	66	81	110	123	133
Fit length (mm)	C	16	27	31	34.5	42	50	47
Inside diameter from Ø to Ø H7 (mm)	D _{1/2}	5 - 20	10 - 28	12 - 32	19 - 42	30 - 60	35 - 60	40 - 72
Max. inside diameter clamping hub (mm)	D _{max}	24	30	32	42	60	60	75
With keyway - max Ø H7 (mm)	D _{1/2}	17	23	29	36	60	60	66
ISO 4762 clamping screws	E	M4	M6	M8	M10	M12	M16	M16
Tightening torque (Nm)		5	15	40	70	130	200	250
Distance between centers (mm)	F	15	19	23	27	39	41	48
Distance (mm)	G	5	7.5	9.5	12	14	17	19
Length bellows body (mm)	H	39.5	52	64	72	83	96	95
Clamping length (mm)	I	10	15	19	22	28	33.5	37.5
Outside diameter tube section (mm)	K	35	50	60	76	100	110	120
Length (mm)	O	11.5	17	21	24	30	35	40
Shaft average value (mm)	N	25	34	41	47	56	66	65

For maximum misalignment values see page 16.

ORDERING EXAMPLE	ZAL	10	1551	18	19.05	XX
Model	●					
Size		●				
Overall length mm			●			
Bore D1 H7				●		
Bore D2 H7					●	
For custom features place an XX at the end of the part number and describe the special requirements (e.g. ZAL/10/1551/18/19.05/XX; XX=anodized aluminum hubs)						

EZ2

WITH FULLY SPLIT CLAMPING HUB

12.5 - 25,000 Nm



ABOUT

FEATURES

- ▶ easy installation and removal
- ▶ standard lengths up to 4 meters
- ▶ no intermediate support bearings required

MATERIAL

- ▶ **Hubs:** up to size 450 high strength aluminum, size 800 steel, size 2500 and up GGG40
- ▶ **Intermediate tube:** up to size 450 high strength aluminum, size 800 and up steel, optional CFK tube on request

- ▶ **Elastomer insert:** wear resistant, thermally stable TPU

DESIGN

Two fully split clamping hubs, with two clamping screws in each, and concave driving jaws. Backlash free, vibration damping, electrically isolating elastomer inserts press fit into the hubs. Precision intermediate tube with a high level of straightness and lateral stiffness.

DESIGN | SIZE 10 - 800

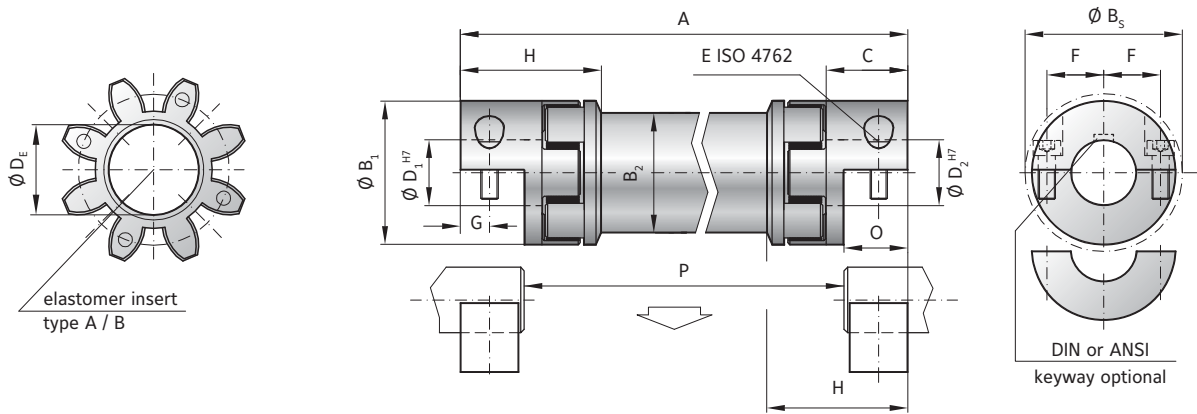

DESIGN | SIZE 2,500 - 9,500

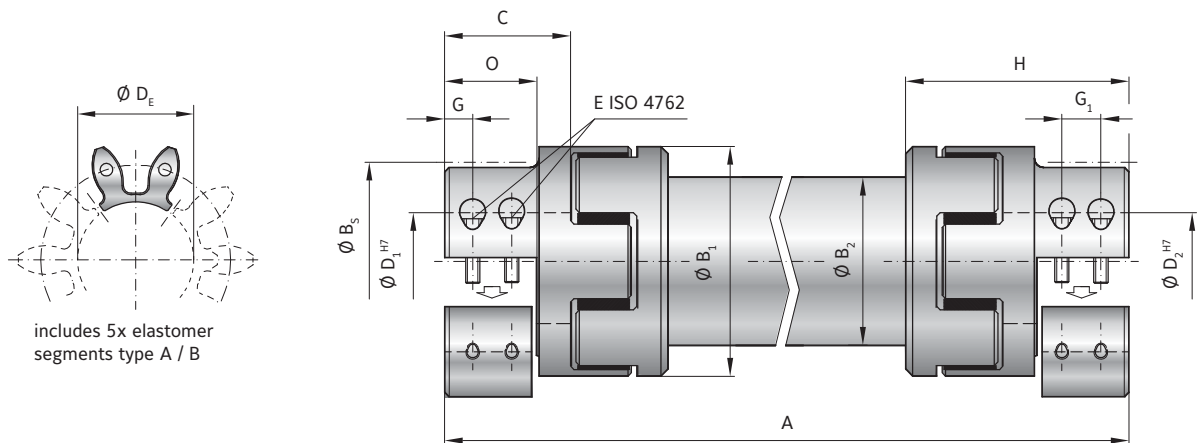

For details on the elastomer inserts see pages 66-67.

MODEL EZ2

SIZE		10		20		60		150		300		450		800		2500		4500		9500	
Type (Elastomer insert)		A	B	A	B	A	B	A	B	A	B	A	B	A	B	A	B	A	B	A	B
Rated torque (Nm)	T_{KN}	12.5	16	17	21	60	75	160	200	325	405	530	660	950	1,100	1,950	2,450	5,000	6,200	10,000	12,500
Max. torque* (Nm)	T_{Kmax}	25	32	34	42	120	150	320	400	650	810	1060	1350	1,900	2,150	3,900	4,900	10,000	12,400	20,000	25,000
Overall length (mm)	A	95 - 4,000		130 - 4,000		175 - 4,000		200 - 4,000		245 - 4,000		280 - 4,000		320 - 4,000		460 - 4,000		580 - 4,000		710 - 4,000	
Outside diameter hub (mm)	B_1	32		42		56		66.5		82		102		136.5		160		225		290	
Outside diameter tube (mm)	B_2	28		35		50		60		76		90		120		150		175		220	
Outside diameter with screwhead (mm)	B_3	32		44.5		57		68		85		105		139		155		190		243	
Fit length (mm)	C	20		25		40		47		55		65		79		85		110		140	
Inside diameter range from \emptyset to \emptyset H7 (mm)	$D_{1/2}$	5 - 16		8 - 25		14 - 32		19 - 36		19 - 45		24 - 60		35 - 80		35 - 90		40 - 120		50 - 140	
Max. inside diameter (Elastomer insert) (mm)	D_E	14.2		19.2		26.2		29.2		36.2		46.2		60.5		80		111		145	
Mounting screw ISO 4762	E	4 x M4		4 x M5		4 x M6		4 x M8		4 x M10		4 x M12		4 x M16		4 x M16		8 x M16		8 x M24	
Tightening torque (Nm)		4		8		15		35		70		120		290		300		300		980	
Distance between centers (mm)	F	10.5		15.5		21		24		29		38		50.5		57		72.5		90	
Distance (mm)	G/G ₁	7.5		8.5		15		17.5		20		25		30		36		24 / 34		30 / 48	
Coupling length (mm)	H	34		46		63		73		86		99		125		142		181		229	
Moment of inertia per hub (10^{-3} kgm ²)	J_1/J_2	0.01		0.02		0.15		0.21		1.02		2.3		17		30		140		450	
Inertia of tube per meter (10^{-3} kgm ²)	J_3	0.075		0.183		0.66		1.18		2.48		10.6		38		360		750		1,800	
Combined dynamic torsional stiffness of the inserts (Nm/rad)	C_{Tdyn}^E	270	825	1,270	2,220	3,970	5,950	6,700	14,650	11,850	20,200	27,700	40,600	41,300	90,000	87,500	108,000	168,500	371,500	590,000	670,000
Torsional stiffness of tube per meter (Nm/rad)	C_T^{ZWR}	321		1,530		6,632		11,810		20,230		65,340		392,800		1,000,000		2,500,000		5,000,000	
Shaft average value (mm)	N	26		33		49		57		67		78		94		108		137		171	
Length (mm)	O	16.6		18.6		32		37		42		52		62		67		85		105	

* Maximum transmittable torque of the clamping hub depends on the bore diameter (see pages 70-71).

INSTALLATION

The overall length A is best determined as the distance between shaft ends P plus 2x dimension O.

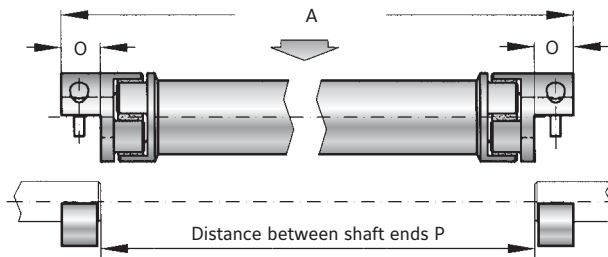

ORDERING EXAMPLE	EZ2	20	1200	A	24	19.05	XX
Model	●						Special designation only (e.g. special bore tolerance).
Size		●					
Overall length mm			●				
Elastomer insert type				●			
Bore D1 H7					●		
Bore D2 H7						●	
For custom features place an XX at the end of the part number and describe the special requirements (e.g. EZ2/20/1200/A/24/19.05/XX; XX=anodized aluminum)							

ADJUSTABLE LENGTH WITH FULLY SPLIT CLAMPING HUB 12.5 - 1,200 Nm



ABOUT

FEATURES

- ▶ telescoping for adjustable length and rotational orientation
- ▶ very easy to install and remove
- ▶ no intermediate support bearings required
- ▶ length ranges up to 4 meters

MATERIAL

- ▶ **Hubs:** high strength aluminum
- ▶ **Intermediate tube:** highly straight and concentric aluminum tubing
- ▶ **Elastomer insert:** wear resistant, thermally stable TPU

DESIGN

Two fully split clamping hubs, with two clamping screws in each, and concave driving jaws. Backlash free, vibration damping, electrically isolating elastomer inserts press fit into the hubs. Precision intermediate tube with a high level of straightness and lateral stiffness. Outer tube clamps over inner tube to fix the overall length.

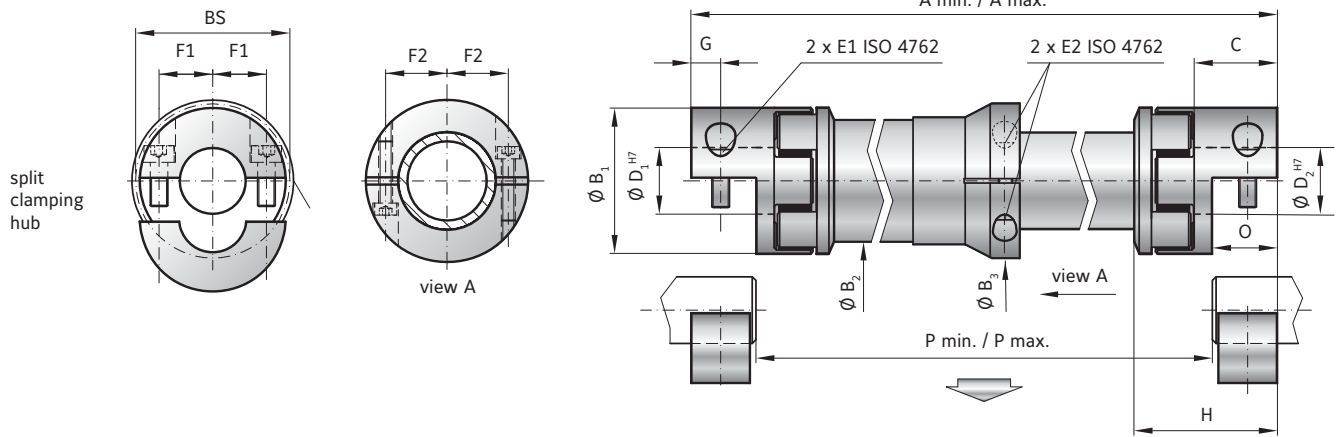

For details on the elastomer inserts see pages 66-67.

FUNCTIONAL DESCRIPTION

The maximum extended length relates to the minimum collapsed length. The formulas to the right can be used to determine the corresponding values.

Information on sizing, torsional stiffness, misalignment ratings, etc. can be found on pages 16-18.

$$\text{Maximum extended length} = (\text{collapsed length} \times 2) - \text{measurement} (X1 + X2)$$

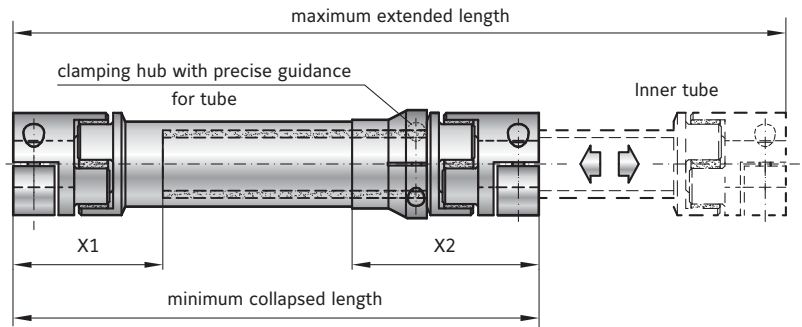

$$\text{Minimum collapsed length} = \frac{\text{maximum extended length} + \text{dimension} (X1 + X2)}{2}$$

MODEL EZV

SIZE			10		20		60		150		300		450	
Type (Elastomer insert)			A	B	A	B	A	B	A	B	A	B	A	B
Rated torque (Nm)	T_{RN}		12.5	16	17	21	60	75	160	200	325	405	530	660
Max. torque* (Nm)	T_{Kmax}		25	32	34	42	120	150	320	400	650	810	1060	1200
Inserted min. length from - to (mm)	A_{min}		150 - 2,055		200 - 2,075		250 - 2,095		300 - 2,115		350 - 2,130		400 - 2,150	
Extended over all length from - to (mm)	A_{max}		190 - 4,000		250 - 4,000		310 - 4,000		370 - 4,000		440 - 4,000		500 - 4,000	
Measurement (mm)	X1+X2		115		156		197		240		280		312	
Outside diameter clamping hub (mm)	B_1		32		42		56		66.5		82		102	
Outside diameter tube (mm)	B_2		28		35		50		60		80		90	
Outside diameter center hub (mm)	B_3		41.5		47		67		77		102		115	
Outside diameter with screwhead (mm)	B_s		32		44.5		57		68		85		105	
Fit length (mm)	C		20		25		40		47		55		65	
Inside diameter from ϕ to ϕ H7 (mm)	D_{J2}		5 - 16		8 - 25		14 - 32		19 - 35		19 - 45		24 - 60	
Screw ISO 4762	E_1		M4		M5		M6		M8		M10		M12	
Tightening torque (Nm)			4		8		15		35		70		120	
Screw ISO 4762	E_2		M4		M4		M5		M6		M8		M10	
Tightening torque (Nm)			4		4.5		8		18		35		70	
Distance between centers (mm)	$F_{10.5}$		10.5		15.5		21		24		29		38	
Distance between centers (mm)	F_2		15		18		26		31		41		45	
Distance (mm)	G		7.5		8.5		15		17.5		20		25	
Coupling length (mm)	H		34		46		63		73		86		99	
Shaft average value (mm)	N		26		33		49		57		67		78	
Length (mm)	O		16.6		18.6		32		37		42		52	
Moment of inertia coupling half (10^{-3} kgm ²)	J_1/J_2		0.01		0.02		0.15		0.21		1.02		2.3	
Inertia of tube per meter (10^{-3} kgm ²)	J_3		0.075		0.183		0.66		1.18		2.48		10.6	
Combined dynamic torsional stiffness of the inserts (Nm/rad)	C_{Tdyn}^E		270	825	1,270	2,220	3,970	5,950	6,700	14,650	11,850	20,200	27,700	40,600
Torsional stiffness of tube per meter (Nm/rad)	C_T^{ZWR}		321		1,530		6,632		11,810		20,230		65,340	

*Maximum transmittable torque of the clamping hub depends on the bore diameter (see pages 70-71).

ORDERING EXAMPLE	EZV	20	1200	A	24	19.05	XX
Model	●						Special designation only (e.g. special bore tolerance).
Size		●					
Collapsed length			●				
Elastomer insert type				●			
Bore D1 H7					●		
Bore D2 H7						●	
For custom features place an XX at the end of the part number and describe the special requirements (e.g. EZV/20/1200/A/24/19.05/XX; XX=anodized aluminum)							





SIZES FROM 350 – 20,000 Nm

TORSIONALLY STIFF DISC PACK COUPLINGS

GENERAL INFORMATION ABOUT R+W DISC PACK COUPLINGS:



SERVICE LIFE

R+W disc pack couplings are fatigue resistant and wear free for an infinite service life, as long as the technical limits are not exceeded.

FIT CLEARANCE

Overall shaft / hub clearance of 0.01 - 0.05 mm

TEMPERATURE RANGE

-30 to +280° C

ROTATIONAL SPEED

see table





DELIVERY

LP couplings are delivered with the disc packs pre-assembled. They need only to be mounted to the hubs.

ATEX (Optional)

For use in hazardous zones 1/21 and 2/22, the disc pack coupling has been authorized under directive 94/9/EG and is available with certification.

TORSIONALLY STIFF DISC PACK COUPLINGS SIZES FROM 350 – 20,000 Nm

MODEL		FEATURES	
LP1		<p>with keyway mounting from 350 - 20,000 Nm</p> <ul style="list-style-type: none"> ▶ very high torsional stiffness ▶ single flex design ▶ compact layout ▶ compensates for axial and angular misalignment 	Page 128
LP2		<p>with keyway mounting from 350 - 20,000 Nm</p> <ul style="list-style-type: none"> ▶ high torsional stiffness ▶ double flex design ▶ customer specified length available ▶ compensates for axial, angular, and lateral misalignment 	Page 129
LP3		<p>with conical clamping ring from 350 - 20,000 Nm</p> <ul style="list-style-type: none"> ▶ high torsional stiffness ▶ high clamping pressure ▶ backlash free torque transmission ▶ good for high speed, reversing and intermittent loading 	Page 130
LPA		<p>with keyway mounting for API 610 pump systems from 350 - 20,000 Nm</p> <ul style="list-style-type: none"> ▶ customizable for individual project requirements ▶ intermediate tube removable without disturbing adjacent equipment ▶ integral safety catch in case of disc pack rupture ▶ customer specified DBSE available 	Page 131

DESIGN

DISC PACK COUPLINGS

R+W disc pack couplings transmit torque across the disc pack assemblies purely by friction, thus avoiding stress concentration, backlash, and micro-movements resulting from transmitting torque across the shoulder bolts. This aids in approaching infinite life in addition to making the complete coupling assembly more torsionally stiff.

R+W disc pack couplings are shipped as individual components. Assembly is required.



MISALIGNMENT COMPENSATION

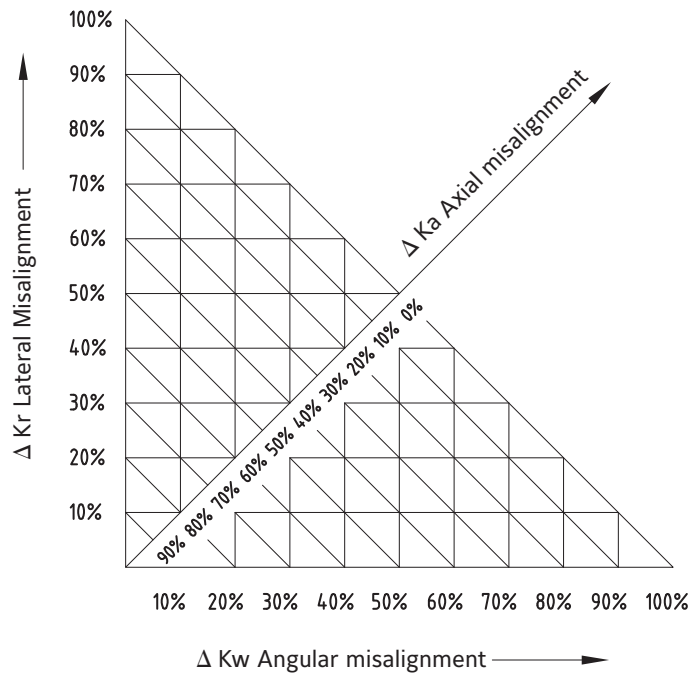

$$\Delta K_{total} = \Delta K_r + \Delta K_w + \Delta K_a \leq 100\%$$

These couplings compensate for varying combinations of shaft misalignment types as percentages of the total allowable misalignment values listed in the data tables. The total sum of the three misalignment percentages must not exceed 100%.

Example: pump skid

- axial misalignment: 20%
- lateral misalignment: 40%
- angular misalignment: 40%

$$\Delta K_{total} = 20\% + 40\% + 40\% \leq 100\%$$

➔ coupling is fatigue resistant

LP1

WITH KEYWAY MOUNTING

350 - 20,000 Nm



ABOUT

FEATURES

- ▶ very high torsional stiffness
- ▶ single flex design
- ▶ wear and maintenance free

MATERIAL

- ▶ **Disc pack:** highly elastic spring steel
- ▶ **Hubs:** high strength steel

DESIGN

Two precision machined coupling hubs mounted to the disc pack by means of high strength screws and bushings for alignment and frictional clamping of the assembly. Axial retention with DIN 916 set screws.

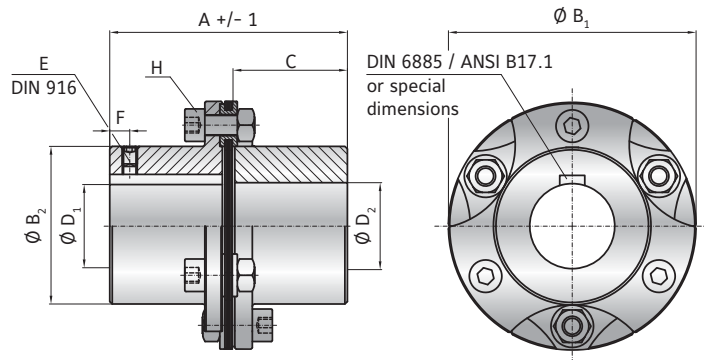

MODEL LP1

SIZE			300	700	2000	4000	7000	10000
Rated torque (Nm)	T_{KN}		350	700	2000	4500	7600	10000
Maximum torque (Nm)	T_{Kmax}		700	1400	4000	9000	15200	20000
Overall length (mm)	A		95	116	158	193	216	268
Outside diameter (mm)	B_1		99	128	150	198	238	298
Hub diameter (mm)	B_2		63	78	86	120	140	194
Hub fit length (mm)	C		45	55	75	90	100	125
Bore diameter available from \emptyset to \emptyset H7 (mm)	$D_{1/2}$		18 - 48	25 - 58	28 - 64	38 - 90	50 - 102	70 - 140
Set screw (DIN 916)	E		see table (depends on bore diameter)*					
Distance to screw (mm)	F		15	15	20	20	25	30
Assembly screw (ISO 4762) Nut (DIN 934)	H		M8	M10	M16	M20	M24	M24
Tightening torque (Nm)			38	75	320	650	1000	1100
Moment of inertia (10^{-3}kgm^2)	$J_{ges.}$		1.8	5.6	13.9	52.2	127	412
Material			steel	steel	steel	steel	steel	steel
Approximate weight (kg)			2	3.8	6.7	13.3	20.9	41.4
Torsional stiffness (10^3Nm/rad)	C_T		470	1200	1500	3600	6000	13300
Axial \pm (mm)			1	1.5	2	2.5	2.5	3
Angular \pm (degree)			0.7°	0.7°	0.7°	0.7°	0.7°	0.7°
Maximum speed (1/min.)			10000	8000	6000	5000	4500	4000
Bore range \emptyset (mm)			\emptyset 18 - 30	\emptyset 30.1 - 44	\emptyset 44.1 - 65	\emptyset 65.1 - 85	\emptyset 85.1 - 110	\emptyset 110.1 - 140
Set screw size*			M5	M8	M10	M12	M16	M20

ORDERING EXAMPLE	LP1	700	42	38.1	XX
Model	●				Special designation only (e.g. special bore tolerance).
Size		●			
Bore D1 H7			●		
Bore D2 H7				●	
For custom features place an XX at the end of the part number and describe the special requirements (e.g. LP1/700/42/38.1/XX; XX=stainless steel hubs)					

LP2

WITH KEYWAY MOUNTING

350 - 20,000 Nm

ABOUT

FEATURES

- ▶ high torsional stiffness
- ▶ double flex design
- ▶ customer specified length available

MATERIAL

- ▶ **Disc packs:** highly elastic spring steel
- ▶ **Hubs and spacer:** high strength steel

DESIGN

Two precision machined coupling hubs and precision spacer tube mounted to the disc packs by means of high strength screws and bushings for alignment and frictional clamping of the assembly. Axial retention with DIN 916 set screws.

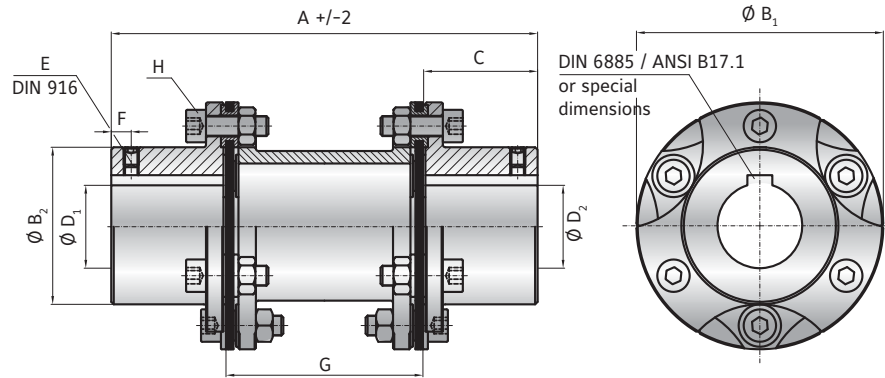

MODEL LP2

SIZE		300	700	2000	4000	7000	10000
Rated torque (Nm)	T_{KN}	350	700	2000	4500	7600	10000
Maximum torque (Nm)	T_{Kmax}	700	1400	4000	9000	15200	20000
Overall length (mm)	A	170 186	206 226	286 292	320 340	370 394	470 482
Outside diameter (mm)	B_1	99	128	150	198	238	298
Hub diameter (mm)	B_2	63	78	86	120	140	194
Hub fit length (mm)	C	45	55	75	90	100	125
Bore diameter available from \emptyset to \emptyset H7 (mm)	$D_{1/2}$	18 - 48	25 - 58	28 - 64	38 - 90	50 - 102	70 - 140
Set screw (DIN 916)	E	see table (depends on bore diameter)*					
Distance to screw (mm)	F	15	15	20	20	25	30
Distance (mm)	G	80 96	96 116	136 142	140 160	170 194	220 232
Assembly screw (ISO 4762) Nut (DIN 934)	H	M8	M10	M16	M20	M24	M24
Tightening torque (Nm)		38	75	320	650	1000	1100
Moment of inertia (10^{-3}kgm^2)	J_{ges}	3 3.1	7.4 7.7	25 25.2	89.3 90.4	230 236	721 726
Material		steel	steel	steel	steel	steel	steel
Approximate weight (kg)		3	4.7	11	20.7	35	68.8
Torsional stiffness (10^3Nm/rad)	C_T	220	550	700	1700	2800	6200
Axial \pm (mm)		1	1.5	2	2.5	2.5	3
Lateral \pm (mm)		0.8 1	1 1.3	1.4 1.5	1.4 1.6	1.6 1.9	2.2 2.4
Angular \pm (degree)		1°	1°	1°	1°	1°	1°
Maximum speed (1/min.)		10000	8000	6000	5000	4500	4000
Bore range \emptyset (mm)		\emptyset 18 - 30	\emptyset 30.1 - 44	\emptyset 44.1 - 65	\emptyset 65.1 - 85	\emptyset 85.1 - 110	\emptyset 110.1 - 140
Set screw size*		M5	M8	M10	M12	M16	M20

ORDERING EXAMPLE	LP2	700	206	38.1	42	XX
Model	●					Special designation only (e.g. special bore tolerance).
Size		●				
Overall length mm			●			
Bore D1 H7				●		
Bore D2 H7					●	
For custom features place an XX at the end of the part number and describe the special requirements (e.g. LP2/700/206/38.1/42/XX; XX=stainless steel hubs and spacer)						

DISC PACK COUPLINGS LP

LP3

WITH CONICAL CLAMPING RING

350 - 20,000 Nm



ABOUT

FEATURES

- ▶ high torsional stiffness
- ▶ high clamping pressure
- ▶ backlash free torque transmission
- ▶ good for high speed, reversing and intermittent loading

DESIGN

Two precision machined conical clamping ring hubs and precision spacer tube mounted to the disc packs by means of high strength screws and bushings for alignment and frictional clamping of the assembly.

MATERIAL

- ▶ **Disc packs:** highly elastic spring steel
- ▶ **Hubs and spacer:** high strength steel

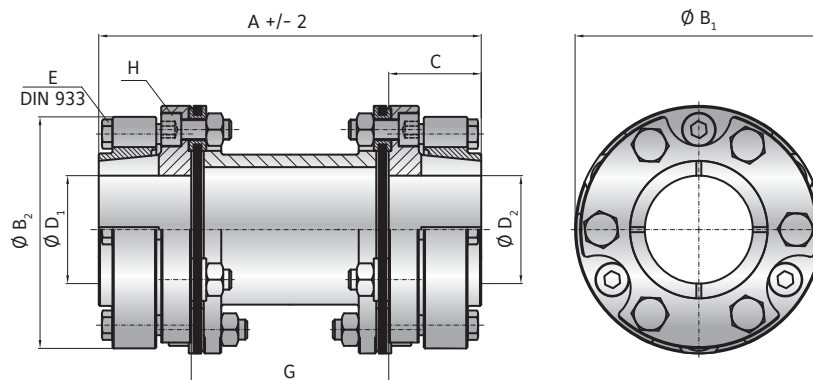

MODELL LP3

SERIE			300	700	2000	4000	7000	10000
Rated torque (Nm)	T_{KN}		350	700	2000	4500	7600	10000
Maximum torque (Nm)	T_{Kmax}		700	1400	4000	9000	15200	20000
Overall length (mm)	A		153	198	303	321	410	490
Outside diameter (mm)	B_1		99	128	150	198	238	298
Hub diameter (mm)	B_2		95	125	146	194	234	294
Hub fit length (mm)	C		37	51	71	92	120	135
Bore diameter* available from \emptyset to \emptyset H7 (mm)	$D_{1/2}$		24 - 50	30 - 65	35 - 70	50 - 100	60 - 115	70 - 170
Clamping screws (ISO 4017)	E		6x M8	6x M10	6x M12	6x M16	6x M20	6x M20
Tightening torque (Nm)			25	50	100	250	470	500
Distance (mm)	G		79	100	161	137	170	220
Assembly screw (ISO 4762) Nut (DIN 934)	H		M8	M10	M16	M20	M24	M24
Tightening torque (Nm)			38	75	320	650	1000	1100
Moment of inertia (10^{-3}kgm^2)	$J_{ges.}$		4.2	16.2	44.5	167	468	1280
Material			steel	steel	steel	steel	steel	steel
Approximate weight (kg)			3.2	7.3	14.8	31.4	59.3	98.4
Torsional stiffness (10^3Nm/rad)	C_T		220	550	700	1700	2800	6200
Axial \pm (mm)			1	1.5	2	2.5	2.5	3
Lateral \pm (mm)			0.8	1	1.5	1.4	1.6	2.2
Angular \pm (degree)			1°	1°	1°	1°	1°	1°
Maximum speed (1/min.)			10000	8000	6000	5000	4500	4000

* transmittable torque can depend on the bore diameter (contact supplier for details)

ORDERING EXAMPLE	LP3	700	198	42	38.1	XX
Model	●					Special designation only (e.g. special bore tolerance).
Size		●				
Overall length			●			
Bore D1 H7				●		
Bore D2 H7					●	
For custom features place an XX at the end of the part number and describe the special requirements (e.g. LP3/700/198/42/38.1/XX; XX=stainless steel hubs and spacer)						



FOR API 610 REQUIREMENTS

350 - 20,000 Nm

ABOUT



FEATURES

- ▶ meets all requirements of API 610
- ▶ intermediate tube removable without disturbing adjacent equipment
- ▶ integral safety catch in case of disc pack rupture
- ▶ ISO G6.3 / AGMA class 9 minimum balance quality
- ▶ highly customizable

- ▶ **Hubs and spacer:** high strength steel

DESIGN

Two precision machined coupling hubs and precision spacer tube mounted to the disc packs by means of high strength screws and bushings for alignment and frictional clamping of the assembly. Axial retention with DIN 916 set screws.

MATERIAL

- ▶ **Disc packs:** highly elastic, corrosion resistant spring steel

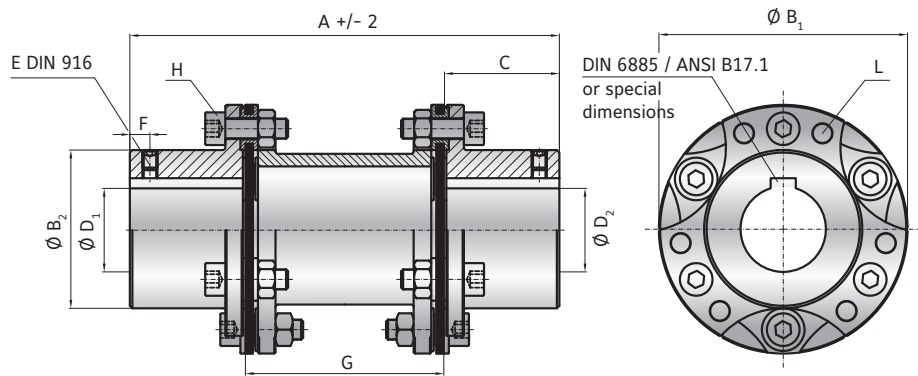

MODEL LPA

SIZE		300	700	2000	4000	7000	10000
Rated torque (Nm)	T_{KN}	350	700	2000	4500	7600	10000
Maximum torque (Nm)	T_{Kmax}	700	1400	4000	9000	15200	20000
Overall length (mm)	A	190 230	250 290	330 400	360 430	380 450	500 550
Outside diameter (mm)	B_1	104	130	160	202	248	312
Hub diameter (mm)	B_2	63	78	86	120	140	194
Hub fit length (mm)	C	45	55	75	90	100	125
Bore diameter available from \emptyset to \emptyset H7 (mm)	$D_{1/2}$	18 - 48	25 - 58	28 - 64	38 - 90	50 - 102	70 - 140
Set screw (DIN 916)	E	see table (depends on bore diameter)*					
Distance to screw (mm)	F	15	15	20	20	25	30
Distance (mm)	G	100 140	140 180	180 250	180 250	180 250	250 300
Assembly screw (ISO 4762) Nut (DIN 934)	H	M8	M10	M16	M20	M24	M24
Tightening torque (Nm)		38	75	320	650	1000	1100
Safety catch screws (DIN 916)	L	M6	M8	M10	M12	M16	M20
Moment of inertia ($10^{-3}Nm/kgm^2$)		3 3.1	7.4 7.7	25 25.2	89.3 90.4	230 236	721 726
Material		steel	steel	steel	steel	steel	steel
Approximate weight (kg)		3	4.7	11	20.7	35	68.8
Torsional stiffness ($10^3Nm/rad$)	C_T	220	550	700	1700	2800	6200
Axial \pm (mm)		1	1.5	2	2.5	2.5	3
Lateral \pm (mm)		0.8 1	1 1.3	1.4 1.5	1.4 1.6	1.6 1.9	2.2 2.4
Angular \pm (degree)		1°	1°	1°	1°	1°	1°
Maximum speed (1/min.)		10000	8000	6000	5000	4500	4000

Bore range \emptyset	\emptyset 18 - 30	\emptyset 30.1 - 44	\emptyset 44.1 - 65	\emptyset 65.1 - 85	\emptyset 85.1 - 110	\emptyset 110.1 - 140
Set screw size*	M5	M8	M10	M12	M16	M20

ORDERING EXAMPLE	LPA	700	250	42	38.1	XX
Model	●					
Size		●				
Overall length mm			●			
Bore D1 H7				●		
Bore D2 H7					●	

Special designation only (e.g. special hub for large bore).

For custom features place an XX at the end of the part number and describe the special requirements (e.g. LPA/700/250/42/38.1/XX; XX=with puller holes)





**FOR USE IN
HAZARDOUS AREAS**





FOR USE IN HAZARDOUS AREAS PRECISION COUPLINGS

MARKING EXAMPLE

Based on the ATEX markings the product can be certified for suitability under certain conditions.

	II	2G	c	IIA T6	X
	II	2D	c	85°C	X
	Equipment group	Category	Protection type	Explosion group / temperature class / maximum surface temperature	Additional features

Equipment group	Approval type
I	approved for underground operation
II	approved for all other applications

Category	Approved for zone	Zone description
1G	0	Area in which an explosive atmosphere consisting of a mixture of air and flammable gases, vapors, or mists, is present continuously, frequently, or for long periods of time.
2G	1	Area in which the potential exists for an explosive mixture of air and flammable gases, vapors, or mists to occur.
3G	2	Area in which the potential for an explosive mixture of air and flammable gases, vapors, or mists to occur is unlikely and only for a brief duration.
1D	20	Area with the same conditions as zone 0, with powder or dust.
2D	21	Area with the same conditions as zone 1, with powder or dust.
3D	22	Area with the same conditions as zone 2, with powder or dust.

Protection type	Definition
c	Design safety level: ignition hazard is avoided by the product design.

Example classification by occurring gases, mists and vapors according to temperature class and explosion group

Explosion group / temperature class / maximum surface temperature	IIA	IIB (includes IIA)	IIC (includes IIA + IIB)
T1 / 450°C	acetone, ammonia, methane...	natural gas	hydrogen
T2 / 300°C	ethyl alcohol, butane, cyclohexane...	ethylene, ethylene oxide	ethyne (acetylene)
T3 / 200°C	gasoline, diesel fuel, fuel oil...	ethylene glycol, hydrogen sulfide	
T4 / 135°C	acetaldehyde	ethyl ether	
T5 / 100°C			
T6 / 85°C			carbon disulphide

Additional labeling	Definition
X	Special operating conditions
U	Product is only a component in a machine. Conformity therefore shall only be declared after installation.

ATEX BELLOWS COUPLINGS

CONSTRUCTION

Dimensions and materials of the standard models remain largely intact.

PERFORMANCE RATINGS

All permitted misalignment, speed, and torque ratings of the standard models must be reduced by 30%.

OPERATION

ATEX metal bellows couplings must only be operated inside a sealed housing. Both the input and output shafts must be monitored to guarantee shut down in the case of coupling failure.

With blind mate style bellows couplings it is also necessary to guarantee electrical continuity between both shafts. This is necessary due to the electrically isolating properties of the coupling, and the need to prevent sparking from any electrostatic charges.

SAMPLE IDENTIFICATION



Type: BK2/60/EEEx - 2013
II 2G c T4
II 2D c 135°C
Ser.No.: 123456.7
Tech.Ref.No.:2003/003RW



Type: BK5/60/EEEx - 2013
II 2G c T4
II 2D c 135°C
Ser.No.: 123456.7
Tech.Ref.No.:2003/006RW

ATEX ELASTOMER COUPLINGS

CONSTRUCTION

Dimensions and materials of the standard models remain largely intact.

For ATEX elastomer couplings the inserts come in version "D" (Sh65D) which is electrically conductive to provide continuity for any potential electrostatic charges.

PERFORMANCE RATINGS

All permitted misalignment, speed, and torque ratings of the standard models must be reduced by 30%.

OPERATION

In the case of model TX thermoplastic hub elastomer couplings it is also necessary to guarantee electrical continuity between both shafts. This is necessary due to the electrically isolating properties of the coupling, and the need to prevent sparking from any electrostatic charges.

SAMPLE IDENTIFICATION



Type: EK2/60/EEEx - 2013
II 2G c T4
II 2D c 135°C
Ser.No.: 123456.7
Tech.Ref.No.:2003/001RW



Type: TX1/60/EEEx - 2013
II 2G c IIA T6
II 2D c 85°C
Ser.No.: 123456.7
Tech.Ref.No.:2003/001RW



FOR USE IN HAZARDOUS AREAS PRECISION COUPLINGS

ATEX SAFETY COUPLINGS

CONSTRUCTION

Dimensions and materials of the standard models remain largely intact.

Generally full disengagement style safety couplings are used in ATEX environments in order to avoid high temperatures from excess friction after disengagement.

For ES2 safety couplings the inserts come in version "D" (Sh65D) which is electrically conductive to provide continuity for any potential electrostatic charges.

PERFORMANCE RATINGS

All permitted misalignment and speed ratings of the standard models must be reduced by 30%.

OPERATION

ATEX safety couplings must be used with an ATEX proximity switch. The emergency stop function in conjunction with activation of the switch must be fully tested for proper function prior to commissioning of the machine.

When bellows couplings are incorporated they must only be operated inside a sealed housing. Both the input and output shafts must be monitored to guarantee shut down in the case of bellows failure.

With blind mate style bellows couplings it is also necessary to guarantee electrical continuity between both shafts. This is necessary due to the electrically isolating properties of the coupling, and the need to prevent sparking from any electrostatic charges.

SAMPLE IDENTIFICATION



Type: SK2/60/EEEx - 2013
II 2G c T3
II 2D c 200°C
Ser.No.: 123456.7
Tech.Ref.No.:2003/004RW



Type: ES2/60/(F)EEEx - 2013
II 2G c T3
II 2D c 200°C
Ser.No.: 123456.7
Tech.Ref.No.:2003/002RW

ATEX LINE SHAFTS

CONSTRUCTION

Dimensions and materials of the standard models remain largely intact.

For EZ type line shafts the inserts come in version "D" (Sh65D) which is electrically conductive to provide continuity for any potential electrostatic charges.

PERFORMANCE RATINGS

All permitted misalignment, speed, and torque ratings of the standard models must be reduced by 30%.

The allowable operating speed depends on the overall length of the line shaft and is available upon request.

OPERATION

When bellows couplings are incorporated they must only be operated inside a sealed housing. Both the input and output shafts must be monitored to guarantee shut down in the case of bellows failure.

SAMPLE IDENTIFICATION



Type: EZ2/60/D/EEEx - 2013
II 2G c T4
II 2D c 135°C
Ser.No.: 123456.7
Tech.Ref.No.:2003/005RW



Type: ZA/10/EEEx - 2013
II 2G c T4
II 2D c 135°C
Ser.No.: 123456.7
Tech.Ref.No.:2005/007RW

ATEX DISC PACK COUPLINGS

CONSTRUCTION

Dimensions and materials of the standard models remain largely intact.

PERFORMANCE RATINGS

All permitted misalignment, speed, and torque ratings of the standard models must be reduced by 30%.

OPERATION

Both the input and output shafts must be monitored to guarantee shut down in the case of disc pack failure.

SAMPLE IDENTIFICATION

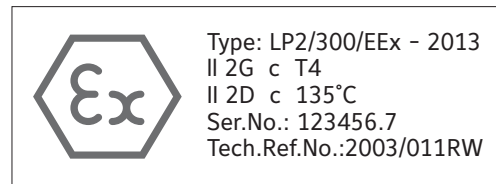

Prior to deviating from any of the previous safety instructions please contact R+W.

The use of devices and components in explosive areas is governed by the European directives 94/9/EC (for manufacturers) and 1992/92/EC (for operators). The presented products are non-electrical equipment of category 2. All necessary documents and certifications are stored in a known location. The conformity of these products with these guidelines is established and may be declared by the manufacturer.

According to Directive 94/9/EC, delivery of an ATEX coupling requires the inclusion of special installation and operating instructions along with the EC declaration of conformity issued by the manufacturer. All necessary values for installation, operation and removal are included.

All statements made about ATEX conforming products are based on our present knowledge and experience. R+W reserves the right to change technical specifications.

PERFECT CONNECTIONS WORLDWIDE.

QUALITY "MADE IN GERMANY."



AUSTRALIA | ARGENTINA | BELGIUM | BOSNIA-HERZEGOVINA | BRAZIL | CHILE | CHINA | DENMARK | ESTONIA | FINLAND | FRANCE | GREECE | UK | INDIA | INDONESIA | ISRAEL | ITALY | JAPAN | CANADA | COLOMBIA | KOREA | CROATIA | LITHUANIA | MALAYSIA | MEXICO | MACEDONIA | MONTENEGRO | NEW ZEALAND | NETHERLANDS | NORWAY | AUSTRIA | PERU | PHILIPPINES | POLAND | PORTUGAL | ROMANIA | RUSSIA | SAUDI ARABIA | SWEDEN | SWITZERLAND | SERBIA | SINGAPORE | SLOVAKIA | SLOVENIA | SPAIN | SOUTH AFRICA | TAIWAN | THAILAND | CZECH REPUBLIC | TURKEY | UKRAINE | HUNGARY | USA | UNITED ARAB EMIRATES

R + W ANTRIEBSELEMENTE GMBH

Alexander-Wiegand-Strasse 8
D - 63911 Klingenberg/Germany
Phone +49 9372 986 40
Fax +49 9372 986 420
info@rw-kupplungen.de
www.rw-kupplungen.de

R+W AMERICA

1120 Tower Lane
Bensenville, IL 60106
USA
Phone +1 630 521 9911
Fax +1 630 521 0366
info@rw-america.com
www.rw-america.com

R+W MACHINERY (SHANGHAI) CO., LTD

Dept. J, 4 Floor, No 207, Tai Gu Road
PRC Waigaoqiao Free Trade Zone
(Postcode 200131)
Shanghai China
Phone +86 21 586 829 86
Fax +86 21 586 829 95
info@rw-china.com
www.rw-china.com

R+W ITALIA S.R.L.

Via Pisa, 134
I - 20099 Sesto San Giovanni (MI)
Phone +39 02 262 641 63
Fax +39 02 243 085 64
info@rw-italia.it
www.rw-italia.it

R+W FRANCE OFFICE

713, route de Tréconnas
F - 01250 Ceyzeriat France
Phone +33 4 74 42 98 37
Fax +33 4 74 45 01 14
info@rw-france.fr
www.rw-france.fr

R+W SINGAPORE OFFICE

55 Market Street #10-00
Singapore 048941
Phone +65 3158 4434
Fax +65 6521 3001
info@rw-singapore.com.sg
www.rw-singapore.com.sge

R+W AMERICA

1120 TOWER LANE
BENSENVILLE, IL 60106, USA
WWW.RW-AMERICA.COM

PHONE: +1 630 521 9911
FAX: +1 630 521 0366
INFO@RW-AMERICA.COM



Version: 01/2013

QUALITY MANAGEMENT

We are certified



according to ISO 9001:2008

D-ZM-16029-01-01 Registration No. 40503432/3

The information included in this document is based on our present knowledge and experience and does not exclude the manufacturer's own substantial testing of the products. Therefore we do not guarantee protection against third party claims. The sale of our product is in accordance with our general terms and conditions.