



**HercuFlex**  
by Lovejoy

FX Series

CX Series

FXL Series

RA/RAHS Series



The Reinvention of the Gear Coupling

# Gear Coupling Selection Process

## Factors Affecting Selection

The following is a list of the information necessary to assist in making a coupling selection. Not all of these items will come into play in all selection processes. These items include, but are not limited to:

- Application details
- Type of motor and driven equipment
- Motor horsepower or KW
- Operating/coupling speed
- Shaft sizes and separation
- Space and size constraints
- Environment (temperature, chemicals, etc)
- Balance requirements
- Special modifications

## Steps In Selecting A Gear Coupling

Refer to the gear coupling specifications charts displayed with each type of coupling throughout this catalog. The pictures and charts provide visualization, specifications, and dimensional data for Lovejoy's HercuFlex gear coupling products. Typically start with an FX Type flanged gear coupling or a CX Type continuous sleeve gear coupling and proceed from there.

**Step 1:** Review the gear coupling series and type as selected to ensure the selection meets application requirements.

**Step 2:** Determine the nominal application torque in in-lbs by using the following formula:

$$\text{Application Torque ( in-lb )} = \frac{(\text{HP} \times 63025)}{\text{RPM}}$$

or

$$\text{Nm} = \frac{(\text{KW} \times 9550)}{\text{RPM}}$$

**Step 3:** Review the Application Service Factor chart for the service factor number associated with the application where this coupling will be used. Multiply the application torque by the application service factor to determine the total torque required for the coupling selection.

**Step 4:** Compare the required total torque value with the nominal torque capacity listed in the Gear Coupling Selection chart for the desired coupling type.

**Step 5:** Check that the maximum bore size and the maximum RPM of the coupling type selected to ensure the coupling will meet these application requirements.

**Step 6:** Note any special requirements including the BSE dimension for floating shaft and spacer types, shear pin torque, slide coupling details, mill motor tapered shaft data, and any other pertinent information.

*Consult with Lovejoy for any unique applications.*

# Application Service Factors

<b>Agitators</b>			
Pure Liquids .....	1.0		
Liquids—Variable Density .....	1.0		
<b>Blowers</b>			
Centrifugal.....	1.0		
Lobe .....	1.2		
<b>Can Filling Machines</b> .....	1.0		
<b>Car Dumpers</b> .....	2.0		
<b>Car Pullers, Intermittent Duty</b> .....	1.5		
<b>Compressors</b>			
Centrifugal.....	1.0		
Reciprocating .....	2.2		
Multi-Cylinder .....	2.0		
Single Cylinder .....	2.0		
<b>Conveyors, Uniformly Loaded or Fed</b>			
Assembly .....	1.2		
Belt .....	1.2		
Screw.....	1.2		
<b>Conveyors, Heavy Duty</b>			
Not Uniformly			
Fed Assembly.....	1.5		
Belt .....	1.5		
Oven .....	1.5		
Reciprocating .....	2.0		
Screw.....	1.5		
Shaker .....	1.5		
<b>Cranes and Hoists<sup>1</sup></b>			
Main Hoists.....	2.0		
Reversing .....	2.0		
Skip Hoists .....	2.0		
Trolley Drive .....	2.0		
Bridge Drive .....	2.0		
<b>Crushers</b>			
Ore .....	3.0		
Stone .....	3.0		
<b>Dredges</b>			
Conveyors.....	2.0		
Cutter Head Drives.....	2.0		
Maneuvering Winches .....	2.0		
Pumps.....	2.0		
<b>Fans</b>			
Centrifugal.....	1.0		
Cooling Towers Forced Draft .....	1.5		
<b>Feeders</b>			
Screw.....	1.5		
<b>Generators</b>			
Not Welding .....	1.0		
Welding .....	1.5		
<b>Hammer Mills</b> .....	2.0		
<b>Laundry Washers</b>			
Reversing .....	1.5		
<b>Lumber Industry</b>			
Barkers—Drum Type.....	2.0		
Edger Feed.....	2.0		
Live Rolls .....	2.0		
Log Haul—Incline.....	2.0		
Log Haul—Well Type .....	2.0		
Off Bearing Rolls .....	2.0		
Planer Feed Chains.....	1.75		
Planer Tilting Hoist .....	1.75		
Planer Floor Chains .....	1.75		
Slab Conveyor.....	1.5		
Sorting Table.....	1.5		
Trimmer Feed .....	1.5		
<b>Machine Tools</b>			
Bending Roll.....	2.0		
Punch Press, Gear Driven.....	2.0		
Tapping Machines .....	2.0		
Main Drives.....	1.5		
Auxiliary Drives.....	1.5		
<b>Metal Mills</b>			
Draw Bench—Carriage.....	2.0		
Draw Bench—Main Drive .....	2.0		
Forming Machines.....	2.0		
Slitters.....	1.5		
Table Conveyors			
Non-Reversing.....	2.25		
Reversing .....	2.5		
Wire Drawing & Flattening Machine .....	2.0		
Wire Winding Machine .....	1.75		
<b>Metal Rolling Mills</b>			
Blooming Mills .....	2.5		
Coilers, hot mill.....	2.0		
Coilers, cold mill.....	1.5		
Cold Mills.....	2.0		
Cooling Beds.....	1.75		
Door Openers .....	2.0		
Draw Benches .....	2.0		
Edger Drives.....	1.75		
Feed Rolls, Reversing Mills.....	3.5		
Furnace Pushers .....	2.5		
Hot Mills .....	3.0		
Ingot Cars .....	2.5		
Kick-outs.....	2.5		
Manipulators.....	3.0		
Merchant Mills .....	3.0		
Piercers .....	3.0		
Pusher Rams .....	2.5		
Reel Drives .....	1.75		
Reel Drums .....	2.0		
Reelers .....	3.0		
Rod and Bar Mills.....	3.0		
Roughing Mill Delivery Table.....	3.0		
Runout Tables .....	2.5		
Saws, hot & cold .....	2.5		
Screwdown Drives.....	3.0		
Skelp Mills.....	3.0		
Slitters.....	3.0		
Slabbing Mills.....	1.75		
Soaking Pit Cover Drives.....	3.0		
Straighteners.....	2.5		
Tables, transfer & runout.....	2.5		
Thrust Block .....	3.0		
Traction Drive .....	3.0		
Tube Conveyor Rolls.....	2.5		
Unscramblers .....	2.5		
Wire Drawing.....	1.75		
<b>Mills, Rotary Type</b>			
Ball .....	2.25		
Dryers & Coolers .....	2.0		
Hammer.....	1.75		
Kilns.....	2.0		
Pebble & Rod .....	2.0		
Pug .....	1.75		
Tumbling Barrels.....	2.0		
<b>Mixers</b>			
Concrete Mixers, Continuous .....	1.5		
Concrete Mixers, Intermittent.....	2.0		
<b>Oil Industry</b>			
Oil Well Pumping .....	2.0		
Rotary Kilns.....	2.0		
<b>Paper Mills</b>			
Agitators, Mixers.....	1.5		
Barker Auxiliaries, Hydraulic .....	2.0		
Barker Mechanical .....	2.0		
Barking Drum Spur			
Gear Only .....	2.0		
Beater & Pulper .....	1.75		
Bleacher.....	1.0		
Calenders.....	2.0		
Calenders, Super.....	1.5		
Chippers .....	2.5		
Coaters .....	1.0		
Converting Machines, except Cutters, Platers.....	1.5		
Conveyors.....	1.5		
Couch Roll .....	1.75		
Cutters, Platters .....	2.0		
Cylinders.....	1.75		
Disc Refiners .....	1.75		
Dryers .....	1.75		
Felt Stretcher.....	1.25		
Felt Whipper .....	2.0		
Jordans .....	1.75		
Line Shaft.....	1.5		
Log Haul .....	2.0		
Pulp Grinder.....	1.75		
Press Roll.....	2.0		
Reel .....	1.5		
Stock Chests .....	1.5		
Suction Roll.....	1.75		
Washers & Thickeners .....	1.5		
Winders .....	1.5		
<b>Printing Presses</b> .....	1.5		
<b>Pumps</b>			
Centrifugal.....	1.0		
Reciprocating			
Single Acting 3 or more Cylinders.....	1.5		
Double Acting 2 or more Cylinders.....	2.0		
Rotary, Gear Type, Lobe Vane .....	1.5		
<b>Rubber Industry</b>			
Mixer .....	2.0		
Rubber Calender.....	2.0		
<b>Screens</b>			
Rotary, Stone or Gravel.....	1.5		
<b>Steering Gear</b> .....	1.0		
<b>Stokers</b> .....	1.0		
<b>Textile Industry</b>			
Dryers .....	1.5		
Dyeing Machinery .....	1.5		
<b>Windlass</b> .....	2.0		

- Notes:**
- 1 indicates: If people are transported, Lovejoy does not recommend and will not warranty the use of the coupling.
  - Values contained in the table should be used as a general guide and are to be applied to smooth power sources such as electric motors and steam turbines.
  - For drives involving internal combustion engines add 1.0 to the values listed.

# FX Series

## Flange Style Gear Coupling

By incorporating the latest advances in Finite Element Analysis technology, Lovejoy has revolutionized the Gear Coupling. Increased nominal torque, larger maximum bore size and longer service life are just a few of the many advantages of the HercuFlex coupling. Despite the advanced nature of these improvements, the HercuFlex Gear Coupling still utilizes the standard AGMA flange interface to ensure field interchangeability.

### Key Features

- Unequaled bore and torque capacity
- 1.5° of misalignment per gear mesh
- Improved fastener corrosion resistance
- Advanced seal design intensifying contamination resistance
- Interchangeable with standard AGMA flange interface



Size	Nominal Torque (in-lb)	Nominal Torque (N-m)	Max Bore (in)	Max Bore (mm)	Max Running Speed (RPM)	
					Unbal	Bal
1	11,300	1,277	1.875	48	6,000	9,000
1.5	26,100	2,949	2.438	62	5,500	8,250
2	44,850	5,067	3.063	78	5,000	7,500
2.5	79,700	9,005	3.625	92	4,400	6,600
3	135,700	15,332	4.250	108	4,000	6,000
3.5	203,550	22,998	5.000	127	3,500	5,250
4	311,540	35,199	5.875	149	3,000	4,500
4.5	427,460	48,296	6.750	171	2,700	4,050
5	584,890	66,084	7.750	197	2,500	3,750
5.5	771,300	87,145	8.625	220	2,200	3,300
6	1,207,500	136,429	9.500	241	2,100	3,150
7	1,638,750	185,154	11.250	287	2,000	3,000

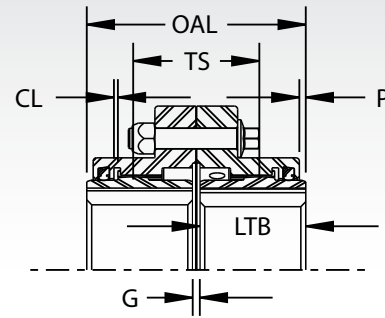
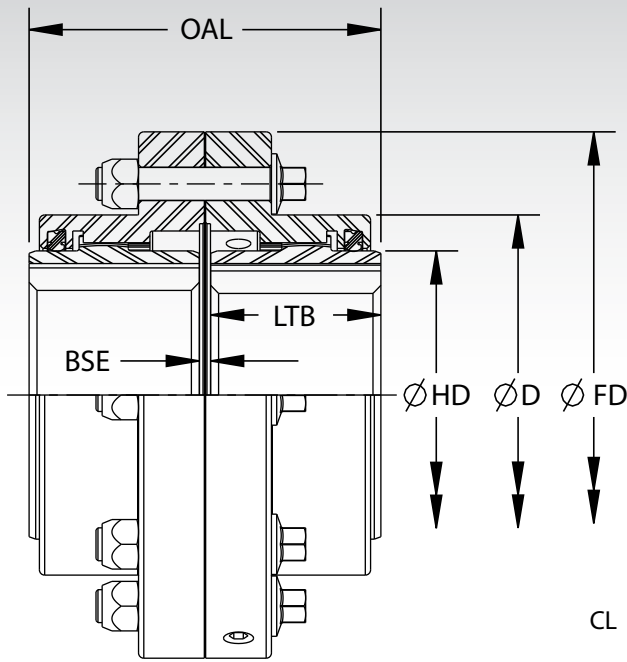

Normal Hub Arrangement

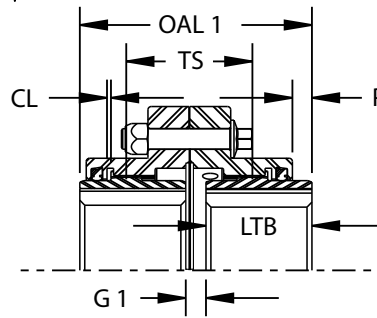

1 Hub Reversed

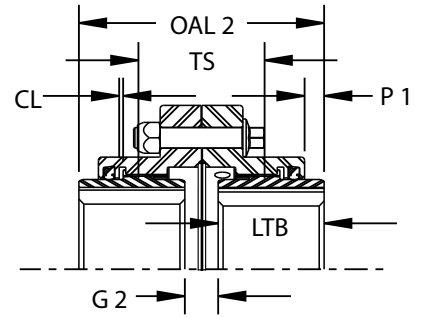

2 Hubs Reversed

**FX Dimensions (Standard Hubs)**

Size	OAL (in)	OAL (mm)	OAL 1 (in)	OAL 1 (mm)	OAL 2 (in)	OAL 2 (mm)	LTB (in)	LTB (mm)	BSE (in)	BSE (mm)	HD (in)	HD (mm)	D (in)	D (mm)
1	3.51	89.2	3.82	97.0	4.13	104.9	1.69	42.9	0.13	3.3	2.49	63.3	3.26	82.8
1.5	4.01	101.9	4.25	108.0	4.49	114.0	1.94	49.3	0.13	3.3	3.29	83.5	4.11	104.3
2	5.01	127.3	5.69	144.5	6.37	161.8	2.44	62.0	0.13	3.3	4.21	106.9	5.10	129.6
2.5	6.25	158.8	7.03	178.6	7.81	198.4	3.03	77.0	0.19	4.8	4.97	126.4	6.17	156.6
3	7.37	187.2	8.04	204.2	8.71	221.2	3.59	91.2	0.19	4.8	5.88	149.4	7.17	182.0
3.5	8.63	219.2	9.20	233.7	9.77	248.2	4.19	106.4	0.25	6.4	6.87	174.5	8.35	212.2
4	9.75	247.7	10.44	265.2	11.13	282.7	4.75	120.7	0.25	6.4	8.10	205.7	9.83	249.8
4.5	10.93	277.6	11.99	304.5	13.05	331.5	5.31	134.9	0.31	7.9	9.09	230.9	10.81	274.7
5	12.37	314.2	13.72	348.5	15.07	382.8	6.03	153.2	0.31	7.9	10.24	260.0	12.13	308.0
5.5	14.13	358.9	15.35	389.9	16.57	420.9	6.91	175.5	0.31	7.9	11.28	286.5	13.13	333.4
6	15.13	384.3	16.54	420.1	17.95	455.9	7.41	188.2	0.31	7.9	12.29	312.2	14.38	365.2
7	17.76	451.1	19.07	484.4	20.38	517.7	8.69	220.7	0.38	9.7	14.30	363.3	16.69	423.9

Size	FD (in)	FD (mm)	TS (in)	TS (mm)	CL (in)	CL (mm)	P (in)	P (mm)	P 1 (in)	P 1 (mm)	G (in)	G (mm)	G 1 (in)	G 1 (mm)	G 2 (in)	G 2 (mm)
1	4.56	115.8	2.13	54.1	0.07	1.7	0.01	0.3	0.32	8.1	0.13	3.3	0.44	11.2	0.75	19.1
1.5	6.00	152.4	2.31	58.7	0.07	1.8	0.12	3.0	0.36	9.1	0.13	3.3	0.37	9.4	0.61	15.5
2	7.00	177.8	3.25	82.6	0.07	1.8	0.12	3.0	0.80	20.3	0.13	3.3	0.81	20.6	1.49	37.8
2.5	8.38	212.9	4.00	101.6	0.10	2.6	0.18	4.6	0.96	24.4	0.19	4.8	0.97	24.6	1.75	44.5
3	9.44	239.8	4.45	113.0	0.09	2.3	0.37	9.4	1.04	26.4	0.19	4.8	0.86	21.8	1.53	38.9
3.5	11.00	279.4	5.01	127.3	0.10	2.4	0.50	12.7	1.07	27.2	0.25	6.4	0.82	20.8	1.39	35.3
4	12.50	317.5	5.69	144.5	0.13	3.4	0.62	15.7	1.31	33.3	0.25	6.4	0.94	23.9	1.63	41.4
4.5	13.63	346.2	6.68	169.7	0.14	3.5	0.65	16.5	1.71	43.4	0.31	7.9	1.37	34.8	2.43	61.7
5	15.31	388.9	7.69	195.3	0.20	5.0	0.65	16.5	2.00	50.7	0.31	7.9	1.66	42.2	3.01	76.5
5.5	16.75	425.5	8.44	214.4	0.19	4.9	1.06	26.9	2.28	57.9	0.31	7.9	1.53	38.9	2.75	69.8
6	18.00	457.2	9.13	231.9	0.16	4.0	0.90	22.9	2.31	58.7	0.31	7.9	1.72	43.7	3.13	79.5
7	20.75	527.1	10.38	263.7	0.19	4.8	1.50	38.0	2.81	71.2	0.38	9.7	1.69	42.9	3.00	76.2



# CX Series

## Continuous Sleeve Style Gear Coupling

The HercuFlex coupling family has expanded to include the continuous sleeve gear coupling. Utilizing the same industry leading design expertise as seen in the FX style, Lovejoy has incorporated multiple innovations to yield previously unseen bore and torque capacity in the Continuous Sleeve gear coupling segment.



### Key Features

- Unequaled bore and torque capacity
- 1.5° of misalignment per gear mesh
- Improved hardware corrosion resistance
- Advanced seal design intensifying contamination resistance



Size	Nominal Torque (in-lb)	Nominal Torque (N-m)	Max Bore (in)	Max Bore (mm)	Max Running Speed (RPM)	
					Unbal	Bal
1	11,300	1,277	1.875	48	6,000	9,000
1.5	26,100	2,949	2.438	62	5,500	8,250
2	44,850	5,067	3.063	78	5,000	7,500
2.5	79,700	9,005	3.625	92	4,400	6,600
3	135,700	15,332	4.250	108	4,000	6,000
3.5	203,550	22,998	5.000	127	3,500	5,250
4	311,540	35,199	5.875	149	3,000	4,500
4.5	427,460	48,296	6.750	171	2,700	4,050
5	584,890	66,084	7.750	197	2,500	3,750
5.5	771,300	87,145	8.625	220	2,200	3,300
6	1,207,500	136,429	9.500	241	2,100	3,150
7	1,638,750	185,154	11.250	287	2,000	3,000

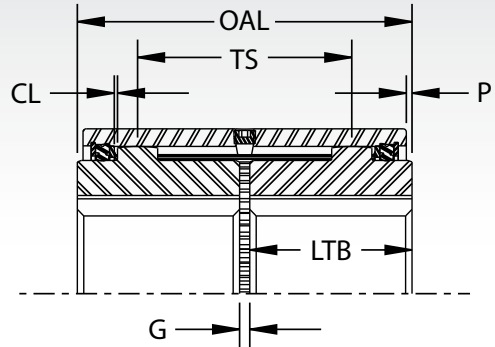
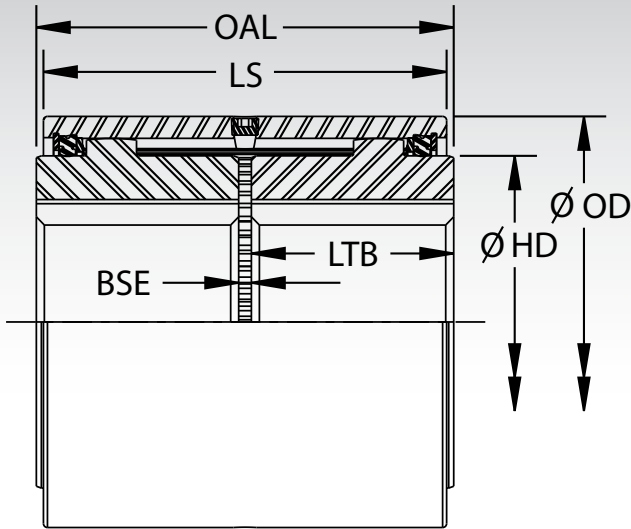

Normal Hub Arrangement

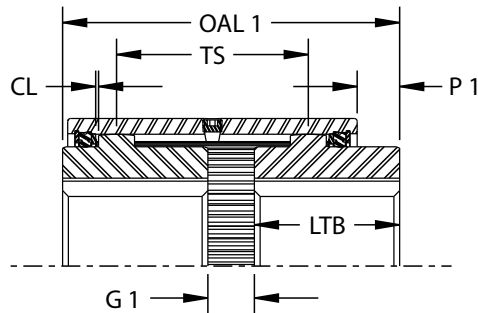

1 Hub Reversed

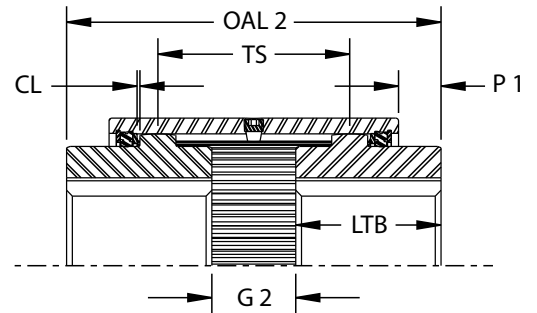

2 Hubs Reversed

**CX Dimensions (Standard Hubs)**

Size	OAL (in)	OAL (mm)	OAL 1 (in)	OAL 1 (mm)	OAL 2 (in)	OAL 2 (mm)	LTB (in)	LTB (mm)	BSE (in)	BSE (mm)	HD (in)	HD (mm)	OD (in)	OD (mm)	TS (in)	TS (mm)
1	3.63	92.2	3.94	100.1	4.25	108.0	1.69	42.9	0.13	3.3	2.49	63.3	3.26	82.8	2.13	54.1
1.5	4.01	101.9	4.25	108.0	4.49	114.0	1.94	49.3	0.13	3.3	3.29	83.5	4.11	104.3	2.31	58.7
2	5.01	127.3	5.69	144.5	6.37	161.8	2.44	62.0	0.13	3.3	4.21	106.9	5.10	129.6	3.25	82.6
2.5	6.25	158.8	7.03	178.6	7.81	198.4	3.03	77.0	0.19	4.8	4.97	126.4	6.17	156.6	4.00	101.6
3	7.37	187.2	8.04	204.2	8.71	221.2	3.59	91.2	0.19	4.8	5.88	149.4	7.17	182.0	4.45	113.0
3.5	8.63	219.2	9.20	233.7	9.77	248.2	4.19	106.4	0.25	6.4	6.87	174.5	8.35	212.2	5.01	127.3
4	9.75	247.7	10.44	265.2	11.13	282.7	4.75	120.7	0.25	6.4	8.10	205.7	9.83	249.8	5.69	144.5
4.5	10.93	277.6	11.99	304.5	13.05	331.5	5.31	134.9	0.31	7.9	9.09	230.9	10.81	274.7	6.68	169.7
5	12.37	314.2	13.72	348.5	15.07	382.8	6.03	153.2	0.31	7.9	10.24	260.0	12.13	308.0	7.69	195.3
5.5	14.13	358.9	15.35	389.9	16.57	420.9	6.91	175.5	0.31	7.9	11.28	286.5	13.13	333.4	8.44	214.4
6	15.13	384.3	16.54	420.1	17.95	455.9	7.41	188.2	0.31	7.9	12.29	312.2	14.38	365.2	9.13	231.9
7	17.76	451.1	19.07	484.4	20.38	517.7	8.69	220.7	0.38	9.7	14.30	363.3	16.69	423.9	10.38	263.7

Size	P (in)	P (mm)	P 1 (in)	P 1 (mm)	G (in)	G (mm)	G 1 (in)	G 1 (mm)	G 2 (in)	G 2 (mm)	LS (in)	LS (mm)	CL (in)	CL (mm)
1	-0.12	-3.0	0.19	4.8	0.13	3.3	0.44	11.2	0.75	19.1	3.63	92.2	0.06	1.5
1.5	0.05	1.3	0.29	7.4	0.13	3.3	0.37	9.4	0.61	15.5	3.90	98.9	0.06	1.5
2	0.00	0.0	0.68	17.3	0.13	3.3	0.81	20.6	1.49	37.8	5.00	126.9	0.06	1.5
2.5	0.10	2.6	0.88	22.4	0.19	4.8	0.97	24.6	1.75	44.5	6.04	153.3	0.06	1.5
3	0.37	9.3	1.04	26.3	0.19	4.8	0.86	21.8	1.53	38.9	6.63	168.3	0.06	1.5
3.5	0.66	16.7	1.23	31.2	0.25	6.4	0.82	20.8	1.39	35.3	7.31	185.6	0.09	2.3
4	0.77	19.5	1.46	37.0	0.25	6.4	0.94	23.9	1.63	41.4	8.21	208.5	0.09	2.3
4.5	0.68	17.3	1.74	44.2	0.31	7.9	1.37	34.8	2.43	61.7	9.56	242.7	0.09	2.3
5	0.60	15.3	1.95	49.6	0.31	7.9	1.66	42.2	3.01	76.5	11.16	283.3	0.13	3.2
5.5	0.98	25.0	2.20	55.9	0.31	7.9	1.53	38.9	2.75	69.8	12.16	308.7	0.13	3.2
6	0.82	20.9	2.23	56.7	0.31	7.9	1.72	43.7	3.13	79.5	13.48	342.3	0.13	3.2
7	1.46	37.0	2.77	70.3	0.38	9.7	1.69	42.9	3.00	76.2	14.84	376.8	0.13	3.2

# FXL Series

## Labyrinth Seal Flanged Gear Coupling

In extreme high contamination environments, Lovejoy has transformed the HercuFlex coupling to integrate an advanced seal design when performance degradation is not tolerable. This advanced gear coupling still encompasses the torque and misalignment capacities that make the HercuFlex coupling an industry leader.

### Key Features

- Unequaled bore and torque capacity
- 1.5° of misalignment per gear mesh
- Improved fastener corrosion resistance
- Advanced seal design intensifying contamination resistance
- Interchangeable with standard AGMA flange interface

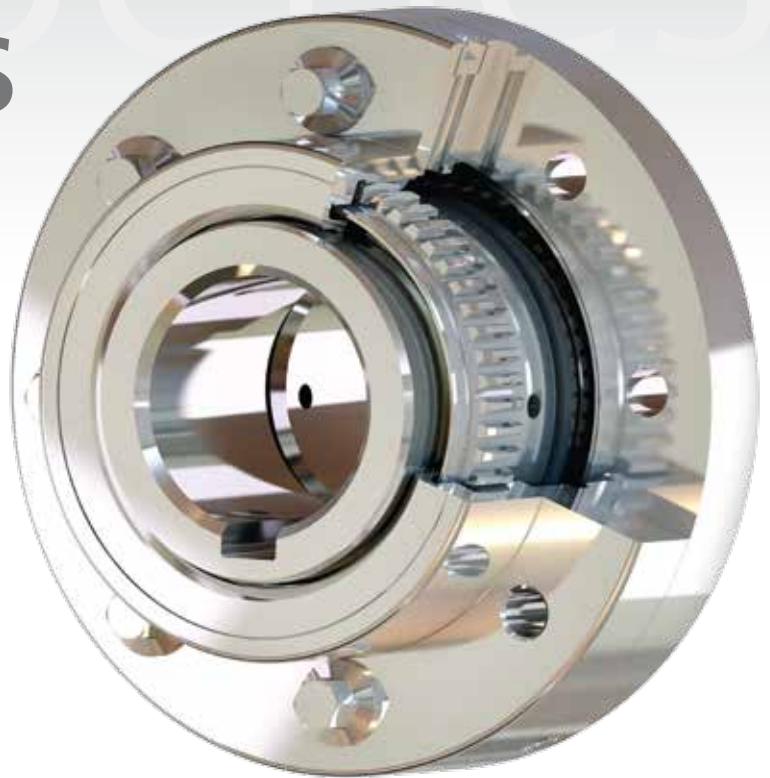

Size	Nominal Torque (in-lb)	Nominal Torque (N-m)	Max Bore (in)	Max Bore (mm)	Max Running Speed (RPM)	
					Unbal	Bal
1	8,000	904	1.563	40	6,000	9,000
1.5	15,000	1,695	2.125	55	5,500	8,250
2	39,000	4,406	2.813	71	5,000	7,500
2.5	69,300	7,830	3.370	85	4,400	6,600
3	118,000	13,332	4.063	100	4,000	6,000
3.5	177,000	19,998	4.750	120	3,500	5,250
4	270,900	30,608	5.675	145	3,000	4,500
4.5	370,700	41,883	6.375	167	2,700	4,050
5	508,600	57,464	7.500	190	2,500	3,750
5.5	670,700	75,779	8.375	212	2,200	3,300
6	1,050,000	118,634	9.375	238	2,100	3,150
7	1,425,000	161,003	11.000	280	2,000	3,000



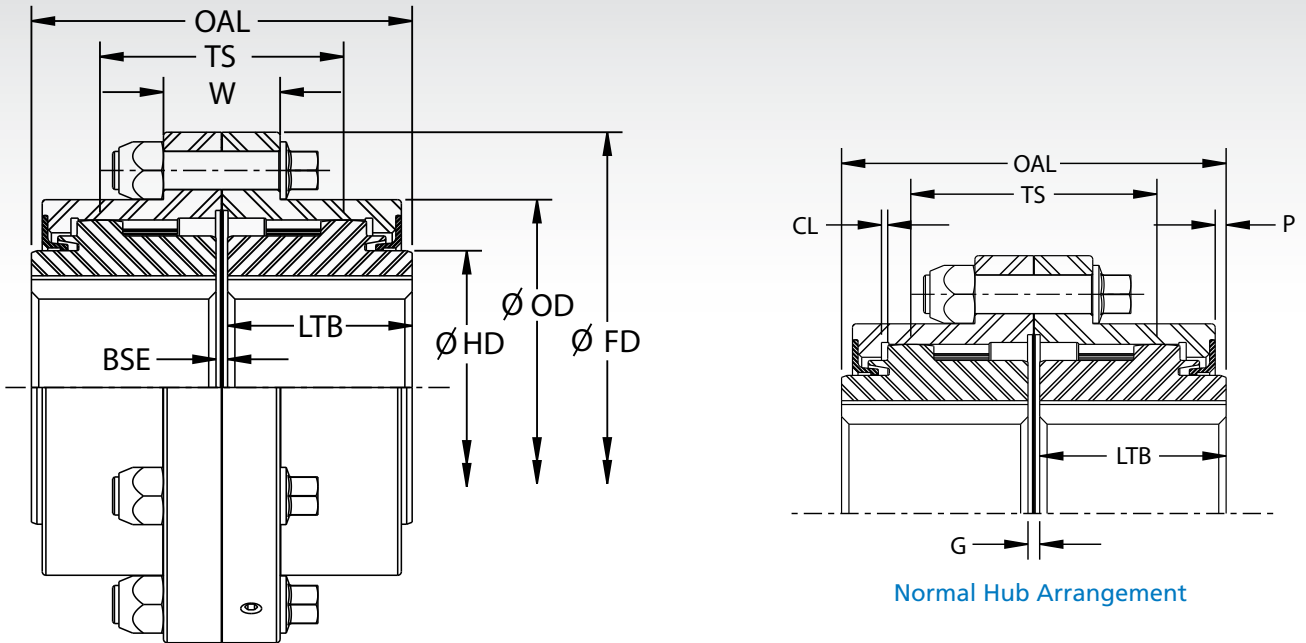

### FXL Dimensions (Standard Hubs)

Size	OAL (in)	OAL (mm)	LTB (in)	LTB (mm)	BSE (in)	BSE (mm)	HD (in)	HD (mm)	OD (in)	OD (mm)	TS (in)	TS (mm)
1	3.63	92.2	1.69	42.9	0.13	3.3	2.06	52.3	3.26	82.8	2.13	54.1
1.5	4.01	101.9	1.94	49.3	0.13	3.3	2.85	72.4	4.11	104.3	2.31	58.7
2	5.01	127.3	2.44	62.0	0.13	3.3	3.75	95.2	5.10	129.6	3.25	82.6
2.5	6.25	158.8	3.03	77.0	0.19	4.8	4.49	114.0	6.17	156.6	4.00	101.6
3	7.37	187.2	3.59	91.2	0.19	4.8	5.38	136.6	7.17	182.0	4.45	113.0
3.5	8.63	219.2	4.19	106.4	0.25	6.4	6.34	161.1	8.35	212.2	5.01	127.3
4	9.75	247.7	4.75	120.7	0.25	6.4	7.41	188.3	9.83	249.8	5.69	144.5
4.5	10.93	277.6	5.31	134.9	0.31	7.9	8.38	212.8	10.81	274.7	6.68	169.7
5	12.37	314.2	6.03	153.2	0.31	7.9	9.51	241.5	12.13	308.0	7.69	195.3
5.5	14.13	358.9	6.91	175.5	0.31	7.9	10.52	267.3	13.13	333.4	8.44	214.4
6	15.13	384.3	7.41	188.2	0.31	7.9	11.55	293.5	14.38	365.2	9.13	231.9
7	17.76	451.1	8.69	220.7	0.38	9.7	13.54	343.8	16.69	423.9	10.38	263.7

Size	G (in)	G (mm)	FD (in)	FD (mm)	TS (in)	TS (mm)	CL (in)	CL (mm)	P (in)	P (mm)
1	0.13	3.3	4.56	115.8	2.13	54.1	0.07	1.7	0.01	0.3
1.5	0.13	3.3	6.00	152.4	2.31	58.7	0.07	1.8	0.12	3.0
2	0.13	3.3	7.00	177.8	3.25	82.6	0.07	1.8	0.12	3.0
2.5	0.19	4.8	8.38	212.9	4.00	101.6	0.10	2.6	0.18	4.6
3	0.19	4.8	9.44	239.8	4.45	113.0	0.09	2.3	0.37	9.4
3.5	0.25	6.4	11.00	279.4	5.01	127.3	0.10	2.4	0.50	12.7
4	0.25	6.4	12.50	317.5	5.69	144.5	0.13	3.4	0.62	15.7
4.5	0.31	7.9	13.63	346.2	6.68	169.7	0.14	3.5	0.65	16.5
5	0.31	7.9	15.31	388.9	7.69	195.3	0.20	5.0	0.65	16.5
5.5	0.31	7.9	16.75	425.5	8.44	214.4	0.19	4.9	1.06	26.9
6	0.31	7.9	18.00	457.2	9.13	231.9	0.16	4.0	0.90	22.9
7	0.38	9.7	20.75	527.1	10.38	263.7	0.19	4.8	1.50	38.0

# Lovejoy® HercuFlex Gear Coupling Flange Interchangeability\*

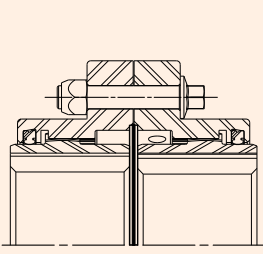
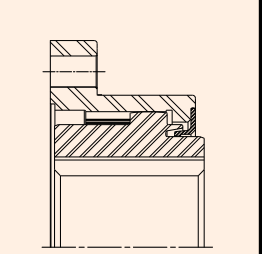
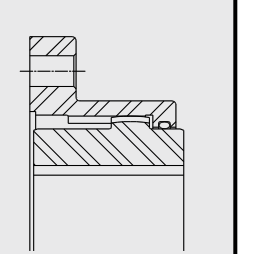
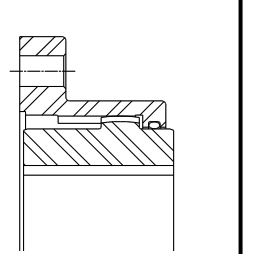
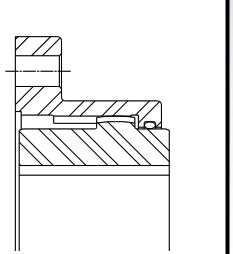
<b>EXPOSED BOLTS</b>																				
	Lovejoy® FX Series				Lovejoy® FXL Series				Lovejoy® F Series				FALK® 1000 Series				FALK® GF Series			
	Size	Torque Rating (in-lb)	Max Bore (in)	Max Bore (mm)	Size	Torque Rating (in-lb)	Max Bore (in)	Max Bore (mm)	Size	Torque Rating (in-lbf)	Max Bore (in)	Max Bore (mm)	Size	Torque Rating (in-lbf)	Max Bore (in)	Max Bore (mm)	Size	Torque Rating (in-lbf)	Max Bore (in)	Max Bore (mm)
	1	11,300	1.875	48	1	8,000	1.563	40	1	7,600	1.625	42	1010G	10,080	1.875	48	1GF	7,600	1.625	41
	1.5	26,100	2.438	62	1.5	15,000	2.125	55	1.5	18,900	2.125	56	1015G	20,790	2.375	60	1-½GF	18,900	2.125	54
	2	44,850	3.063	78	2	39,000	2.813	71	2	31,500	2.750	73	1020G	37,800	2.875	73	2GF	31,500	2.750	70
	2.5	79,700	3.625	92	2.5	69,300	3.375	85	2.5	56,700	3.250	85	1025G	66,150	3.625	92	2-½GF	56,700	3.250	83
	3	135,700	4.250	108	3	118,000	4.063	100	3	94,500	4.000	107	1030G	107,100	4.125	105	3GF	101,000	4.000	102
	3.5	203,550	5.000	127	3.5	177,000	4.750	120	3.5	151,200	4.625	125	1035G	163,800	4.875	124	3-½GF	151,300	4.500	114
	4	311,540	5.875	149	4	270,900	5.688	145	4	220,500	5.375	145	1040G	270,900	5.750	146	4GF	236,000	5.375	137
	4.5	427,460	6.750	171	4.5	370,700	6.375	162	4.5	302,400	6.000	165	1045G	371,700	6.750	171	4-½GF	324,000	6.500	165
	5	584,890	7.750	197	5	508,600	7.500	190	5	434,700	6.500	180	1050G	500,900	7.375	187	5GF	441,000	7.000	178
	5.5	771,300	8.625	220	5.5	670,700	8.375	212	5.5	573,300	7.500	200	1055G	655,200	8.250	210	5-½GF	580,000	7.750	197
6	1,207,500	9.500	241	6	1,050,000	9.375	238	6	749,700	8.250	225	1060G	800,100	9.125	232	6GF	759,000	8.750	222	
7	1,638,750	11.250	287	7	1,425,000	11.000	280	7	1,008,000	9.500	255	1070G	1,197,000	10.000	254					

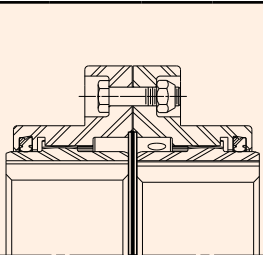
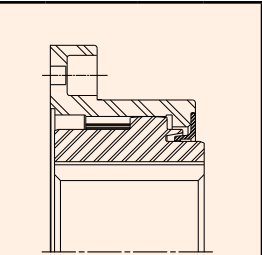
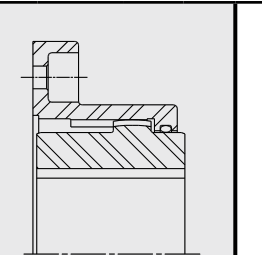
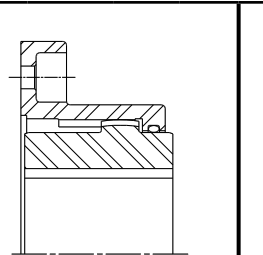
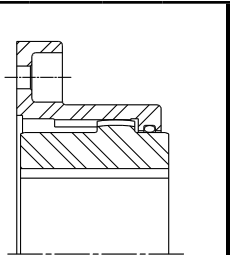
<b>SHROUDED BOLTS</b>																				
	Lovejoy® FX Series				Lovejoy® FXL Series				Lovejoy® F Series				FALK® 1000 Series				FALK® GF Series			
	Size	Torque Rating (in-lb)	Max Bore (in)	Max Bore (mm)	Size	Torque Rating (in-lb)	Max Bore (in)	Max Bore (mm)	Size	Torque Rating (in-lbf)	Max Bore (in)	Max Bore (mm)	Size	Torque Rating (in-lbf)	Max Bore (in)	Max Bore (mm)	Size	Torque Rating (in-lbf)	Max Bore (in)	Max Bore (mm)
	1	11,300	1.875	48	1	8,000	1.563	40	1	7,600	1.625	42	1010G	10,080	1.875	48	1GF	7,600	1.625	41
	1.5	26,100	2.438	62	1.5	15,000	2.125	55	1.5	18,900	2.125	56	1015G	20,790	2.375	60	1-½GF	18,900	2.125	54
	2	44,850	3.063	78	2	39,000	2.813	71	2	31,500	2.750	73	1020G	37,800	2.875	73	2GF	31,500	2.750	70
	2.5	79,700	3.625	92	2.5	69,300	3.375	85	2.5	56,700	3.250	85	1025G	66,150	3.625	92	2-½GF	56,700	3.250	83
	3	135,700	4.250	108	3	118,000	4.063	100	3	94,500	4.000	107	1030G	107,100	4.125	105	3GF	101,000	4.000	102
	3.5	203,550	5.000	127	3.5	177,000	4.750	120	3.5	151,200	4.625	125	1035G	163,800	4.875	124	3-½GF	151,300	4.500	114
	4	311,540	5.875	149	4	270,900	5.688	145	4	220,500	5.375	145	1040G	270,900	5.750	146	4GF	236,000	5.375	137
	4.5	427,460	6.750	171	4.5	370,700	6.375	162	4.5	302,400	6.000	165	1045G	371,700	6.750	171	4-½GF	324,000	6.500	165
	5	584,890	7.750	197	5	508,600	7.500	190	5	434,700	6.500	180	1050G	500,900	7.375	187	5GF	441,000	7.000	178
	5.5	771,300	8.625	220	5.5	670,700	8.375	212	5.5	573,300	7.500	200	1055G	655,200	8.250	210	5-½GF	580,000	7.750	197

\*Note: Special fasteners may be required.

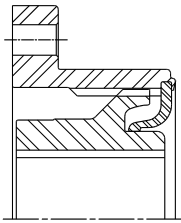
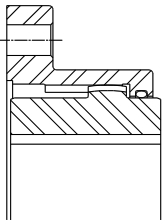
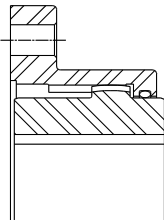
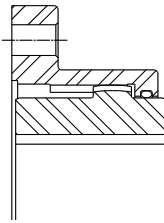
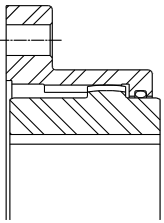
																			
Kop-Flex® FAST				Kop-Flex® H Series				Kop-Flex® Waldron® Series				Renold® Ajax® Series				Ameridrives® Series F			
Size	Torque Rating (in-lbf)	Max Bore (in)	Max Bore (mm)	Size	Torque Rating (in-lbf)	Max Bore (in)	Max Bore (mm)	Size	Torque Rating (in-lbf)	Max Bore (in)	Max Bore (mm)	Size	Torque Rating (in-lbf)	Max Bore (in)	Max Bore (mm)	Size	Torque Rating (in-lbf)	Max Bore (in)	Max Bore (mm)
				1	7,500	1.625	41	1	6,300	1.625	41	1	12,700	1.630	46	201¼	7,600	1.630	41
1 ½	17,000	1.625	41	1 ½	17,000	2.250	57	1 ½	15,100	2.188	56	1-½	23,800	2.130	57	201½	17,000	2.250	57
2	31,500	2.125	54	2	31,500	2.875	73	2	31,500	2.750	70	2	40,600	2.750	78	202	31,500	2.750	70
2 ½	56,700	2.750	70	2 ½	56,700	3.500	89	2 ½	56,700	3.250	83	2-½	65,700	3.250	90	202½	53,600	3.500	89
3	101,000	3.125	79	3	101,000	4.000	102	3	94,500	4.000	102	3	108,000	4.000	110	203	94,500	4.000	102
3 ½	148,000	3.750	95	3 ½	148,000	4.625	117	3 ½	145,000	4.750	121	3-½	166,000	4.500	127	203½	142,000	4.500	114
4	236,000	4.250	108	4	236,000	5.500	140	4	221,000	5.375	137	4	264,000	5.380	145	204	214,000	5.500	140
4 ½	318,000	4.750	121	4 ½	318,000	6.250	159	4 ½	300,000	6.000	152	4-½	365,000	6.000	165	204½	324,000	6.250	159
5	441,000	5.500	140	5	441,000	7.125	181	5	410,000	6.750	171	5	489,000	6.630	185	205	416,000	6.620	168
5 ½	580,000	5.875	149	5 ½	580,000	8.000	203	5 ½	536,000	7.500	191	5-½	725,000	7.500	205	205½	551,000	7.500	191
6	759,000	6.500	165	6	759,000	8.875	225	6	693,000	8.250	210	6	925,000	8.130	225	206	750,000	8.250	210
7	1,160,000	8.000	203	7	1,160,000	10.375	264	7	1,010,000	9.250	235	7	1,390,000	9.630	260	207	1,033,000	9.620	244

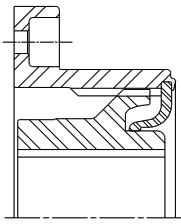
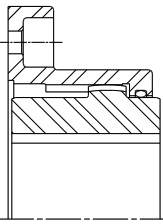
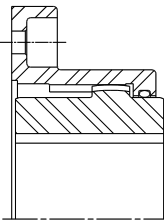
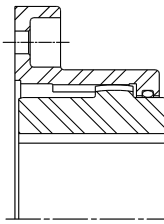
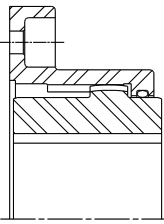
																			
Kop-Flex® FAST				Kop-Flex® H Series				Kop-Flex® Waldron® Series				Renold® Ajax® Series				Ameridrives® Series F			
Size	Torque Rating (in-lbf)	Max Bore (in)	Max Bore (mm)	Size	Torque Rating (in-lbf)	Max Bore (in)	Max Bore (mm)	Size	Torque Rating (in-lbf)	Max Bore (in)	Max Bore (mm)	Size	Torque Rating (in-lbf)	Max Bore (in)	Max Bore (mm)	Size	Torque Rating (in-lbf)	Max Bore (in)	Max Bore (mm)
				1	7,500	1.625	41	1	6,300	1.625	41	1	12,700	1.630	46	201¼	7,600	1.630	41
1 ½	17,000	1.625	41	1 ½	17,000	2.250	57	1 ½	15,100	2.188	56	1-½	23,800	2.130	57	201½	17,000	2.250	57
2	31,500	2.125	54	2	31,500	2.875	73	2	31,500	2.750	70	2	40,600	2.750	78	202	31,500	2.750	70
2 ½	56,700	2.750	70	2 ½	56,700	3.500	89	2 ½	56,700	3.250	83	2-½	65,700	3.250	90	202½	53,600	3.500	89
3	101,000	3.125	79	3	101,000	4.000	102	3	94,500	4.000	102	3	108,000	4.000	110	203	94,500	4.000	102
3 ½	148,000	3.750	95	3 ½	148,000	4.625	117	3 ½	145,000	4.750	121	3-½	166,000	4.500	127	203½	142,000	4.500	114
4	236,000	4.250	108	4	236,000	5.500	140	4	221,000	5.375	137	4	264,000	5.380	145	204	214,000	5.500	140
4 ½	318,000	4.750	121	4 ½	318,000	6.250	159	4 ½	300,000	6.000	152	4-½	365,000	6.000	165	204½	324,000	6.250	159
5	441,000	5.500	140	5	441,000	7.125	181	5	410,000	6.750	171	5	489,000	6.630	185	205	416,000	6.620	168
5 ½	580,000	5.875	149	5 ½	580,000	8.000	203	5 ½	536,000	7.500	191	5-½	725,000	7.500	205	205½	551,000	7.500	191

# Additional Dimensional Data

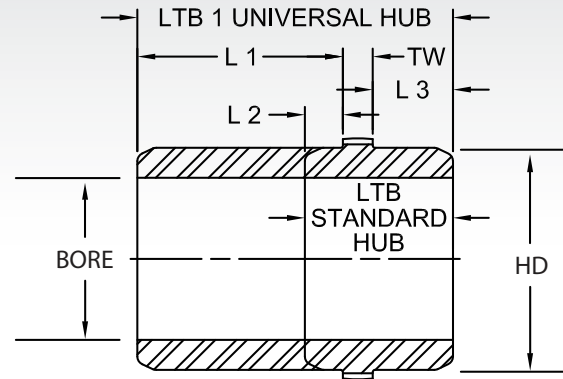

### Hub Dimensions

Size	HD (in)	BORE RSB (in)	L1 (in)	L2 (in)	L3 (in)	TW (in)	LTB STD (in)	LTB 1 UNIV HUB (in)
1	2.49	Solid	2.75	0.44	0.75	0.50	1.69	4.00
1.5	3.29	Solid	3.13	0.57	0.81	0.56	1.94	4.50
2	4.21	Solid	3.63	0.57	1.25	0.62	2.44	5.50
2.5	4.97	1.47	4.22	0.75	1.53	0.75	3.03	6.50
3	5.88	1.47	4.43	1.02	1.69	0.88	3.59	7.00
3.5	6.87	1.84	4.62	1.31	1.88	1.00	4.19	7.50
4	8.10	2.47	4.97	1.47	2.16	1.12	4.75	8.25
4.5	9.09	3.00	5.19	1.50	2.56	1.25	5.31	9.00
5	10.24	3.00	5.06	1.59	2.94	1.50	6.03	9.50
5.5	11.28	4.00	5.56	1.97	3.19	1.75	6.91	10.50
6	12.29	4.00	5.65	1.81	3.22	2.38	7.41	11.25
7	14.30	5.00	7.00	2.50	3.81	2.38	8.69	13.19

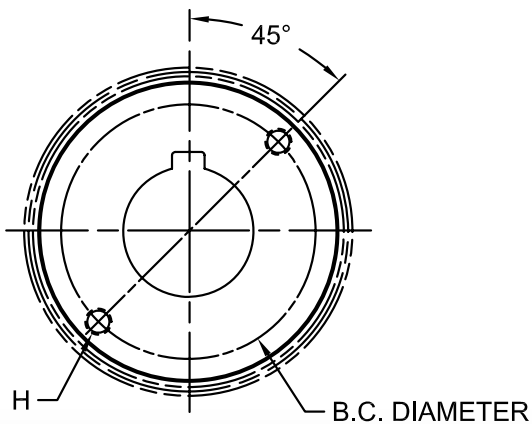

### Flex Hub Puller Bolt Holes

Size	B.C. Diameter (in)	H	
		UNC	Depth
1	None	None	None
1.5	None	None	None
2	3.38	5/16 - 18	0.50
2.5	3.94	3/8 - 16	0.56
3	4.94	1/2 - 13	0.75
3.5	5.56	1/2 - 13	0.75
4	6.44	5/8 - 11	0.94
4.5	7.38	5/8 - 11	0.94
5	8.00	3/4 - 10	1.13
5.5	9.00	1 - 8	1.50
6	9.75	1 - 8	1.50
7	11.63	1 - 8	1.50

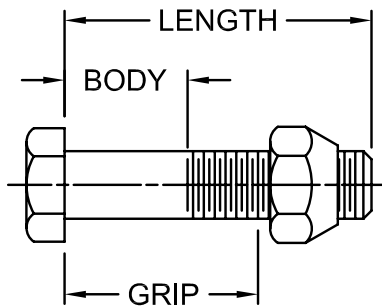
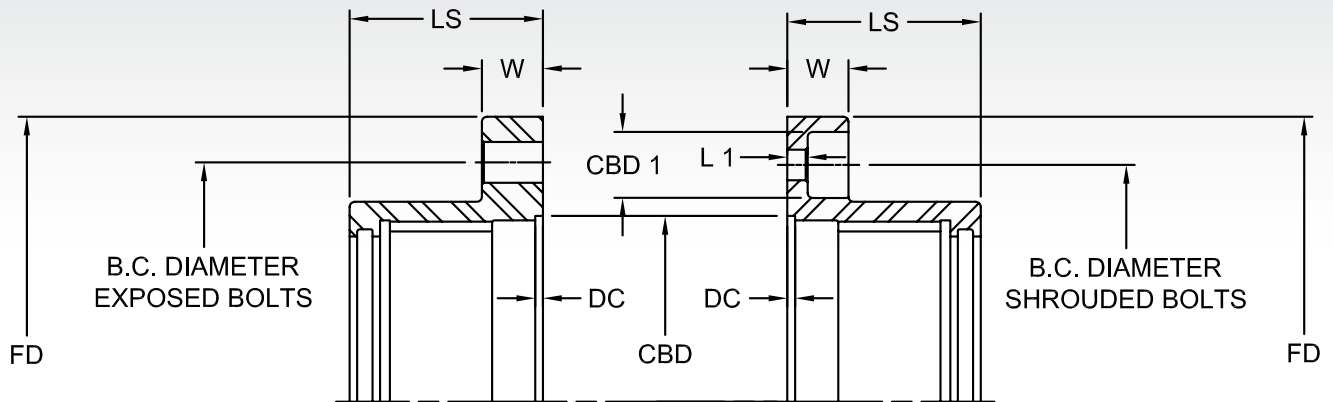

### Sleeve and Bolt Dimensions

Size	LS (in)	W (in)	DC (in)	FD (in)	CBD (in)	EXPOSED BOLTS						CBD 1 (in)	L (in)	SHROUDED BOLTS					
						B.C. Dia. (in)	Qty	THD Size	Length (in)	Min Body (in)	Max Grip (in)			B.C. Dia. (in)	Qty	THD Size	Length (in)	Min Body (in)	Max Grip (in)
1	1.66	0.56	0.09	4.56	3.03	3.750	6	1/4-28	1.50	0.63	1.063	0.64	0.25	3.750	6	1/4-28	0.81	0.281	0.438
1.5	1.88	0.75	0.09	6.00	3.91	4.812	8	3/8-24	2.00	0.88	1.438	0.81	0.25	4.812	8	3/8-24	1.00	0.281	0.438
2	2.38	0.75	0.09	7.00	4.89	5.875	6	1/2-20	2.25	0.88	1.406	0.81	0.25	5.812	10	3/8-24	1.00	0.281	0.438
2.5	2.88	0.88	0.09	8.38	5.81	7.125	6	5/8-18	2.75	1.00	1.656	1.06	0.31	7.000	10	1/2-20	1.25	0.375	0.531
3	3.31	0.88	0.09	9.44	6.73	8.125	8	5/8-18	2.75	1.00	4.656	1.06	0.31	8.000	12	1/2-20	1.25	0.375	0.531
3.5	3.81	1.13	0.09	11.00	7.73	9.500	8	3/4-16	3.25	1.25	2.156	1.31	0.38	9.281	12	5/8-18	1.50	0.438	0.656
4	4.25	1.13	0.19	12.50	9.02	11.000	8	3/4-16	3.25	1.25	2.156	1.31	0.38	10.625	14	5/8-18	1.50	0.438	0.656
4.5	4.81	1.13	0.19	13.63	10.08	12.000	10	3/4-16	3.25	1.25	1.156	1.31	0.38	11.750	14	5/8-18	1.50	0.438	0.656
5	5.50	1.50	0.19	15.31	11.36	13.500	8	7/8-14	4.25	1.69	2.875	1.56	0.56	13.188	14	3/4-16	2.00	0.625	1.031
5.5	6.00	1.50	0.19	16.75	12.58	14.500	14	7/8-14	3.00	1.13	1.750	1.56	0.56	14.437	16	3/4-16	2.00	0.625	1.031
6	6.69	1.00	0.25	18.00	13.75	15.750	14	7/8-14	3.25	1.19	1.875	Exposed Bolts Only							
7	7.38	1.13	0.31	20.75	15.86	18.250	16	1-14	3.50	1.31	2.125								



## RA and RAHS Type Rigid Adjustable Couplings

The RA and RAHS couplings are offered in two different styles. Type II coupling consists of two rigid hubs, adjusting nut and split ring and split ring for motor hub. Type IV coupling consists of two rigid hubs, adjusting nut, and split ring for motor hub and spacer.



### Key Features

- Axial positioning of the pump impeller in vertical pump applications
- Clearance fit bores allows for easy installation and maintenance for pump and/or motor
- Easily adjustable for vertical clearance
- Removable spacer for easy maintenance
- AISI 1045 Steel
- Stainless Steel coupling also available

### RA and RAHS Type Performance Data

Size	HP/100 RPM	Nominal Torque in-lb	Thrust Capacity lbs	Motor & Pump Hubs		Motor & Pump Hubs	
				Min Bore		Max Bore	
				in	mm	in	mm
1125	2.7	1,702	4,500	0.44	11	1.125	29
1625	8.0	5,042	11,000	0.63	16	1.625	42
2125	17.9	11,282	31,000	0.73	18	2.125	56
2625	33.8	21,302	31,000	0.88	22	2.625	70
2875	44.4	27,983	31,000	0.88	22	2.875	77
3125	57.0	35,924	41,000	1.19	30	3.125	84
3875	109.0	68,697	73,000	1.25	31	3.875	103
5000	310.0	195,378	160,000	2.38	60	5.000	135
6000	404.0	254,621	300,000	2.88	73	6.000	167
7250	712.0	448,738	300,000	4.00	101	7.250	194
8500	1148.0	723,527	350,000	4.00	101	8.500	225
10500	2164.0	1,363,861	400,000	5.00	127	10.500	276

### Ordering Information

- Application: Driver and Driven.
- Power: Motor horsepower or torque requirement.
- Speed: Motor Speed or Driven RPM.
- Distance between shaft ends (BSE).
- Shaft sizes.
- Adjusting nut threads.
- Amount of trust on either or both shafts.
- Submit drawing if available.

Item	Description
1	Upper Hub - Motor
2	Lower hub - Pump
3	Spacer
4	Adjusting Nut, Threaded
5	Washer, Split
6	RA and RAHS Accessory Kit
7	RA and RAHS Accessory Kit

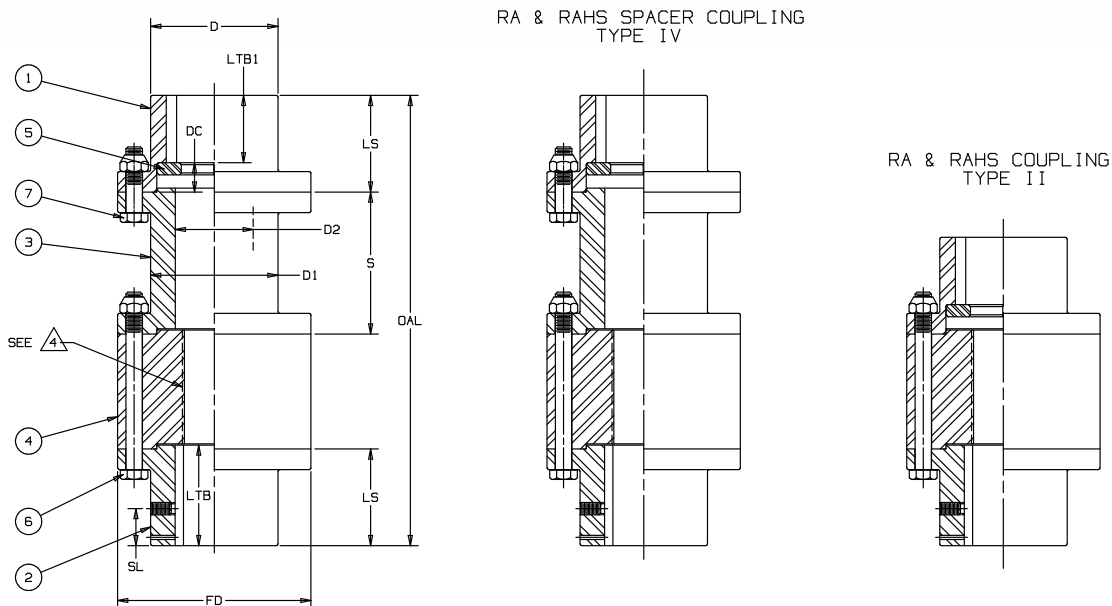

### RA and RAHS Type Dimensional Data

Size	STD OAL		FD	D	LTB	LTB1	LS	DC	N	SL	D1	D2	S		BOLTS		B.C. Dia in
	Type II in	Type IV in											Std in	Min in	Qty	Size	
1125	5.25	9.56	3.00	1.75	2.13	1.11	2.00	0.89	1.25	0.88	1.75	1.25	4.44	1.63	4	1/4 - 28	2.375
1625	6.00	10.31	4.00	2.50	2.38	1.36	2.25	0.89	1.50	0.88	2.50	1.75	4.44	1.75	6	5/16 - 24	3.250
2125	7.13	11.44	5.13	3.13	2.81	1.80	2.69	0.89	1.75	1.00	3.13	2.25	4.44	2.63	6	1/2 - 20	4.250
2625	9.38	13.69	5.88	3.88	3.06	2.05	2.94	0.89	3.50	1.13	3.88	2.75	4.44	2.63	6	1/2 - 20	4.938
2875	10.38	14.69	6.38	4.38	3.56	2.55	3.44	0.89	3.50	1.38	4.38	3.00	4.44	2.88	6	1/2 - 20	5.438
3125	11.50	15.81	6.75	4.63	4.13	3.11	4.00	0.89	3.50	1.63	4.63	3.25	4.44	2.88	8	1/2 - 20	5.813
3875	12.75	17.06	8.94	5.88	4.50	3.48	4.38	0.89	4.00	1.75	5.88	4.00	4.44	3.13	6	3/4 - 16	7.625
5000	15.00	NO STD	11.75	7.50	6.25	4.63	6.00	1.38	3.00	2.44	7.50	5.13	NO STD	4.50	8	1 - 14	10.000
6000	20.88	NO STD	13.25	9.00	9.50	7.63	9.25	1.63	2.38	4.00	9.00	6.13	NO STD	4.75	10	1 - 14	11.500
7250	25.19	NO STD	15.00	10.75	11.06	8.81	10.75	1.94	3.69	4.75	10.75	7.38	NO STD	7.06	14	1 - 14	13.250
7500	33.56	NO STD	17.25	12.50	15.31	13.06	15.00	1.94	3.56	6.63	12.50	8.63	NO STD	7.31	12	1-1/8 - 12	15.000
10500	40.94	NO STD	20.50	15.00	18.69	16.44	18.38	1.94	4.19	8.13	15.00	10.63	NO STD	8.31	12	1-1/8 - 12	18.000

#### Ordering Information

- Clearance fit bores with set screw are standard.
- RA couplings meet standard tolerances.
- Inch bore and keyway tolerances conform to AINSI / AGMA 9002-B04.
- For metric bore and keyway tolerances, consult Lovejoy Application Engineering.
- RAHS couplings conform to API 610 8th edition tolerances.

# HercuFlex Continuous Sleeve Gear Couplings

## Vertical Floating Shaft Type

The upper coupling is a Standard Vertical Type coupling. The lower coupling has a hardened crowned button inserted in the plate of the lower hub and a hardened flat button inserted in the plate of the upper hub. The entire floating assembly rests on these two buttons which carry the weight of the floating assembly thus maintaining the spacing between the two lower hubs allowing for flexibility. The hubs on the floating shaft are flexible and the hubs of the driver and driven shafts are rigid.

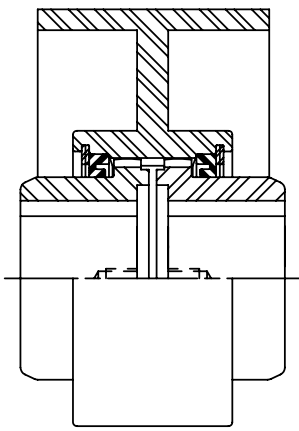
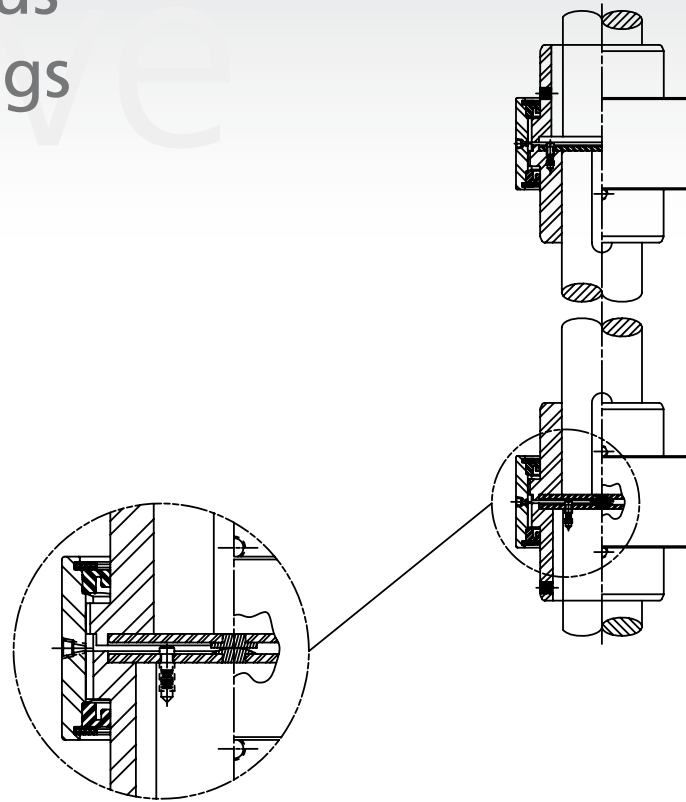

## Brakedrum Type

Two different designs of brakedrum couplings are illustrated. One shows the brakedrum as an intergal part of the sleeve and the two hybs are standard. The other design utilizes one standard hub and a standard sleeve with the brakedrum as part of a special hub.

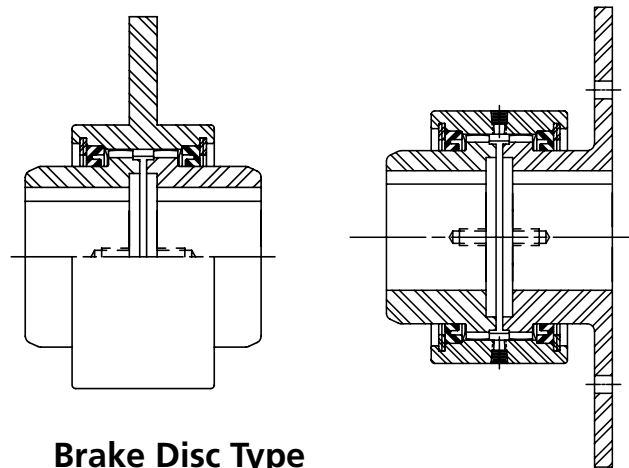

## Brake Disc Type

Two different designs of brake disc couplings are illustrated. One shows the brake disc as an intergal part of the sleeve and the two hybs are standard. The other design utilizes one standard hub and a standard sleeve with the brakedrum as part of a special hub.

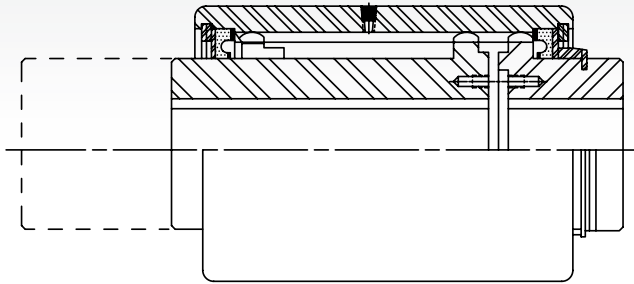

### Sliding Hub Type

The sleeve is longer than standard and is designed to allow for a predetermined amount of axial travel on one shaft. The short hub is secured to the sleeve by means of a spacer washer and snap ring which prevents travel. This type is also manufactured to allow for travel of both hubs in the sleeve. This coupling is also available with a rigid type short hub.

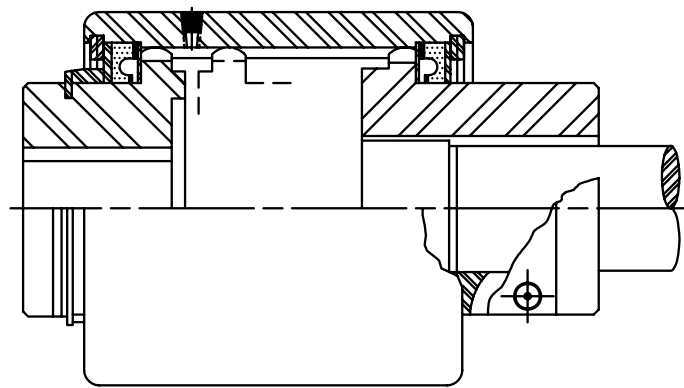

### Jordan Type

Used on Jordan machines and refiners, this design is similar to the Sliding Hub Type coupling except the long hub is split and secured to the shaft with a bolt. This permits for quick axial adjustment of the Jordan shafts in the hub.

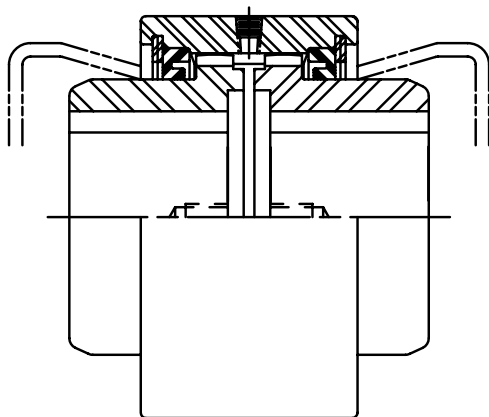

### Continuous Lubricated Type

This coupling is adapted from our Standard Type coupling, except the standard seals have been replaced with the special spacer washers. These washers have a snug fit in the sleeve with sufficient clearance on the hub OD to allow for injection of a continuous stream of lubricant.

## HercuFlex Flanged Sleeve Gear Couplings

### Limited End Float Spacer Type

The addition of plates restricts axial travel to the drive or driven shaft. The spacer makes it possible to remove the hubs from either shaft without disturbing the connected units.

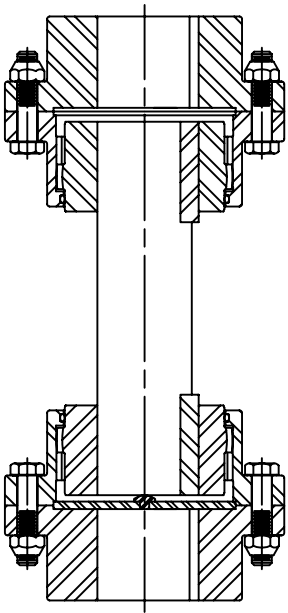
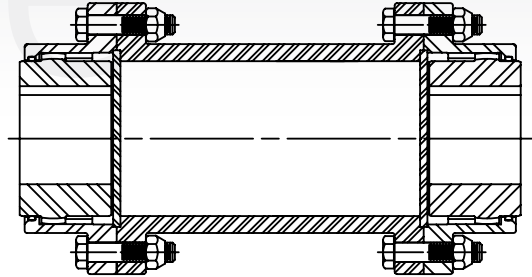

### Vertical Floating Shaft Type

The lower coupling has a hardened crowned button inserted in the plate of the lower hub. The entire floating assembly rest on the button. Optional construction of the upper coupling would be a rigid hub on the floating shaft with a flex half on the top.

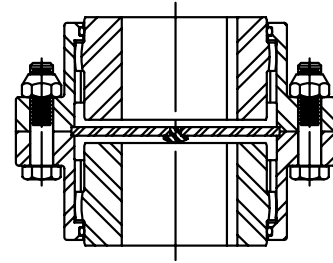

### Vertical Type

This coupling has the same horsepower, RPM and misalignment capabilities as the standard couplings of corresponding sizes. A plate with a hardened crowned button rests on the lower shaft which supports the weight of the sleeve.

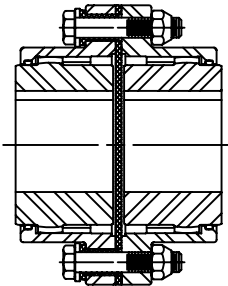

### Insulated Type

Use of a non-metallic material between flanges and around the bolts prevents any stray currents from one shaft to the other.

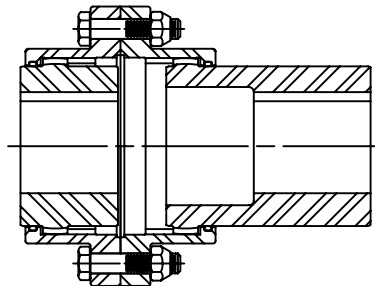

### Jordan Type

Used on Jordan machines and refiners, this design is similar to the slide type coupling except the long hub is split and secured to the shaft with a bolt clamp. This permits quick axial adjustment of the Jordan shafts in this hub.



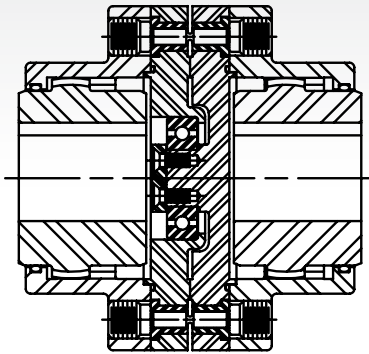

### Engineered Shear Pin Type

Shear pin couplings are primarily used to limit transmitted torque to a redetermined load. This in turn disconnects the driver and driven shafts if torque exceeds the specified limits. They are especially suited to protect equipment when jams occur. Components are re-useable after pins shear. The coupling will retain lubricant for a short period to allow equipment to be shut down.

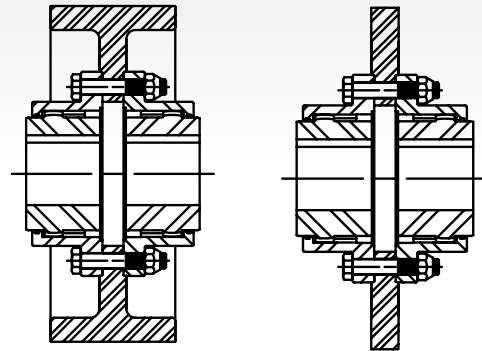

### Brakewheel and Brake Disc Type

Replaceable brakewheel and brake disc piloted on the outside diameter of a standard sleeve and/or rigid hub. Offers a choice of applying braking effort to the load or driving motor.

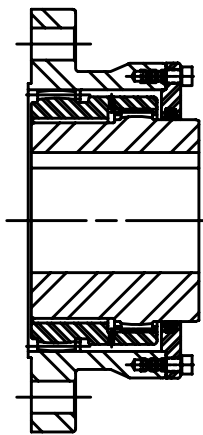

### Double Engagement Half Gear Type

Both internal and external teeth in a single sleeve. Can be bolted to a rotating flywheel, shaft or drum to connect driver or driven machine with a shaft extension. This coupling has the same features, ratings and misalignment capability as the standard group of couplings.

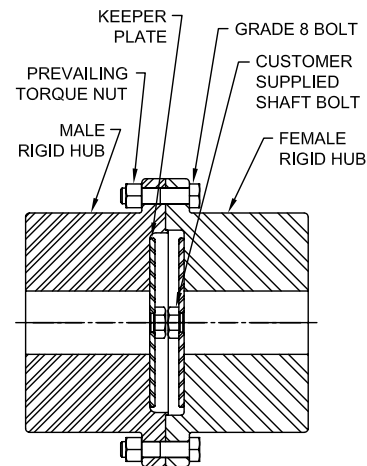

### Rigid Alloy Steel FARR Type

Male/Female piloted rigid coupling coupling with keeper plates. This coupling is used when a rigid connection is required between the low speed shaft of a gearbox and the head shaft of a conveyor, bucket elevator, mixer or any overhung or suspended load.

# Why Coupling Grease?



Adequate lubrication is essential for satisfactory gear coupling operation. Lovejoy Gear Coupling Grease is specifically designed for gear coupling applications to increase coupling life while drastically reducing maintenance time. Its high viscosity base oil and tackifier combine to keep the grease in place and prevent separation and it is in complete compliance with NSI/AGMA 9001-B97 lubrication recommendations.

Lovejoy Coupling Grease is dark brown in color and manufactured with a lithium soap/polymer thickener, which has superior resistance to oil separation when subjected to high centrifugal forces normally found in couplings. Bearing or general purpose greases tend to separate and lose effectiveness due to high centrifugal forces on the various ingredients at high rotational speeds. These high centrifugal forces encountered in couplings separate the base oil from the thickeners. Heavy thickeners, which have no lubrication qualities, accumulate in the gear tooth mesh area resulting in premature coupling failure. Lovejoy Gear Coupling Grease is designed to be highly resistant to centrifugal separation of the oil and thickener, which allows the lubricant to be used for a relatively long period of time.

One of the secrets to the success of Lovejoy Gear Coupling Grease is the variable consistency throughout the working cycle of the application. The consistency of our gear coupling grease changes with the operating conditions. Working of the lubricant under actual service conditions causes the grease to become semi-fluid, functionally solash lubricating the wear surfaces of the coupling. As the grease cools, it returns to the original consistency, thereby preventing leakage.

Lovejoy Gear Coupling Grease is available from stock in 14 oz. cartridges, 1 lb. and 5 lb. cans.

## Features

- Minimizing of coupling wear
- Resistance to water washing
- Corrosion and rust protection
- High load carrying capabilities
- Extended relubrication frequency
- Use at temperatures up to 325° F
- Staying in place under high speeds
- Resistance to centrifugal separation
- Reduction in down time & maintenance cost

Lovejoy Gear Coupling Grease has a consistency which overlaps the NLGI grades 0 and 1. This grease is specially formulated with a lithium/polymer thickener and fortified with corrosion, oxidation, extreme pressure, and an effective rust inhibitor additive package.



## Typical Properties of Lovejoy Gear Coupling Grease

NLGI Grade	0/1
Appearance	Dark Brown, Tacky
Lithium Soap / Polymer, wt%	10.0
Viscosity	
@ 40° C, cST	>3200
@ 100° C, cSt	>50
Penetration. Dmm	
Worked, 60x	350
Worked, 10,000, % Change	10
Dropping Point, ° F	320° (160° C)
Centrifugal Oil Separation, vol%	None
Water Spray-Off, wt%	>3
Rust Protection	Pass
Timken, OK Load, lbs	40+
Four-Bal EP	
Load Wear Index, kgf	68
Weld Point, kgf	400
Four-Ball Wear, mm	
1 hr, 75° C, 1200 RPM, 40 kgf	0.4
Guide to Usable Temperature	
Min, ° F	Below -20° (-29° C)
Continuous Service, Max, ° F	250° (121° C)
Short Exposure, Max, ° F	325° (163° C)

# Selection Worksheet



Customer Name: \_\_\_\_\_ Contact Name: \_\_\_\_\_

Phone Number: \_\_\_\_\_ Email Address: \_\_\_\_\_

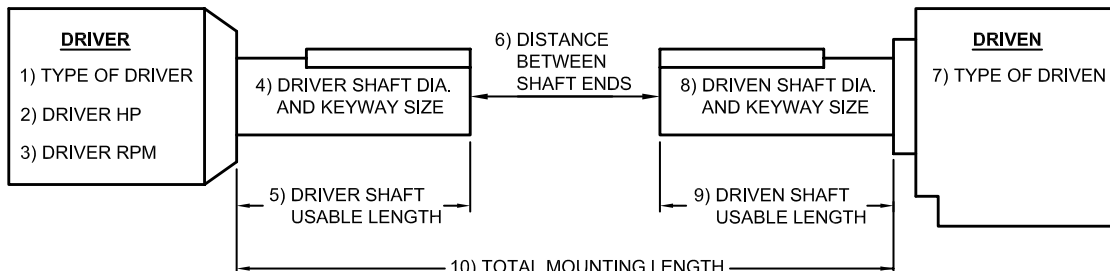

1. Type of Driver (Electric Motor, Combustion Engine, Gearbox, etc.) : \_\_\_\_\_  
 For combustion engines, define type  
 Gasoline, Diesel, Natural Gas, etc. : \_\_\_\_\_ Number of cylinders \_\_\_\_\_
2. Driver Horse Power : \_\_\_\_\_      3. Driver or Gearbox output RPM : \_\_\_\_\_  
 Retrieve the Application Service Factor from page 3 : \_\_\_\_\_ then  
 calculate the Selection Torque using the following formula:  

$$\text{Torque (in-lbs)} = \frac{\text{HP} \times 63025}{\text{RPM}} \times \text{Service Factor} = \text{Selection Torque} = \text{_____ in-lbs}$$
4. Driver Shaft Diameter : \_\_\_\_\_ Keyway size : KW Width \_\_\_\_\_ KW Height \_\_\_\_\_  
 Specify Clearance Fit, Interference Fit, Metric (P7, H7, etc), Shaft Locking Device,  
 and Set Screw or No Set Screw
5. Driver Usable Shaft Length : \_\_\_\_\_ (Measure from the end of the shaft to any obstruction)
6. Distance between shaft ends (BSE) : \_\_\_\_\_
7. Type of Driven Equipment : \_\_\_\_\_
8. Driven Shaft Diameter : \_\_\_\_\_ Keyway size : KW Width \_\_\_\_\_ KW Height \_\_\_\_\_  
 Specify Clearance Fit, Interference Fit, Metric (P7, H7, etc), Shaft Locking Device, and Set Screw or No Set Screw
9. Driven Usable Shaft Length : \_\_\_\_\_ (Measure from the end of the shaft to any obstruction)
10. Total Mounting Length : \_\_\_\_\_ (Advise of any obstructions, walls, beams, guards, pipes, etc.)

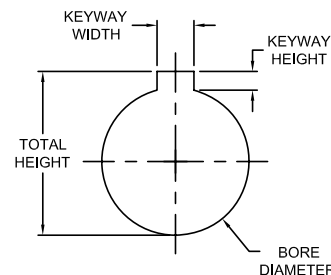

For additional bore and keyway information, see the Engineering Data Section of the Power Transmission Products Catalog

11. For Tapered Shafts specify the following:  
 Minimum or Maximum Taper diameter: \_\_\_\_\_  
 Taper Length: \_\_\_\_\_ T (Taper Inch per Foot) : \_\_\_\_\_  
 Gap or Hub Overhang amount: \_\_\_\_\_  
 Locknut Width: \_\_\_\_\_ Size of nut cross corners: \_\_\_\_\_  
 Thread Size: \_\_\_\_\_ Thread Length: \_\_\_\_\_  
 Washer Diameter (if used) : \_\_\_\_\_ Washer Width: \_\_\_\_\_

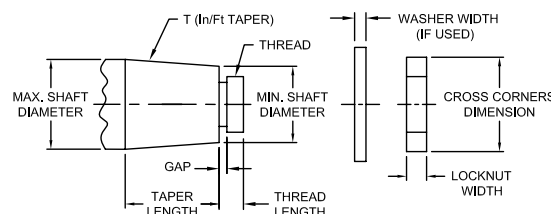

**Lovejoy, Inc.**  
 World Headquarters  
 2655 Wisconsin Avenue, Downers Grove, IL 60515

**Send this form to:** [appleng@lovejoy-inc.com](mailto:appleng@lovejoy-inc.com)  
 or fax to: 800-446-0878



## Safety Warning

When using Lovejoy products, you must follow these instructions and take the following precautions. Failure to do so may cause the power transmission product to break and parts to be thrown with sufficient force to cause severe injury or death.

Refer to this Lovejoy Catalog for proper selection, sizing, horsepower, torque range, and speed range of power transmission products, including elastomeric elements for couplings. Follow the installation instructions included with the product, and in the individual product catalogs for proper installation of power transmission products. Do not exceed catalog ratings.

During start up and operation of power transmission product, avoid sudden shock loads. Coupling assembly should operate quietly and smoothly. If coupling assembly vibrates or makes beating sound, shut down immediately, and recheck alignment. Shortly after initial operation and periodically thereafter, where applicable, inspect coupling assembly for: alignment, wear of elastomeric element, bolt torques, and flexing elements for signs of fatigue. Do not operate coupling assembly if alignment is improper, or where applicable, if elastomeric element is damaged, or worn to less than 75% of its original thickness.

Do not use any of these power transmission products for elevators, man lifts, or other devices that carry people. If the power transmission product fails, the lift device could fall resulting in severe injury or death.

For all power transmission products, you must install suitable guards in accordance with OSHA and American Society of Mechanical Engineers Standards. Do not start power transmission product before suitable guards are in place. Failure to properly guard these products may result in severe injury or death from personnel contacting moving parts or from parts being thrown from assembly in the event the power transmission product fails.

If you have any questions, contact the Lovejoy Engineering Department at 1-630-852-0500.



## Product Warranty

Lovejoy, Inc. warrants all products it manufactures to be free from defects in material and workmanship at the time of delivery to the purchaser. Defective products may be returned to Lovejoy after inspection by the purchaser and upon receipt from Lovejoy of shipping instructions specific to the defective products authorized by Lovejoy to be returned. Products returned in accordance with the foregoing procedure will be replaced or repaired, at the option of Lovejoy, without charge and returned to the purchaser F.O.B. Downers Grove, Illinois or South Haven, Michigan, depending upon origin of manufacture. In all cases, transportation costs and charges for returned products shall be paid by the purchaser and Lovejoy hereby disclaims all responsibility for any and all such transportation costs and charges.

This warranty is subject to the following LIMITATIONS:

The purchaser's exclusive remedy under this warranty is limited to the repair or replacement of defective products supplied by Lovejoy, as set forth above. LOVEJOY IS NOT RESPONSIBLE FOR ANY SPECIAL, INCIDENTAL OR CONSEQUENTIAL DAMAGES RESULTING FROM THE BREACH OF THIS OR ANY OTHER EXPRESS OR IMPLIED WARRANTY WITH RESPECT TO THE PRODUCTS, WHETHER ARISING IN TORT OR BY CONTRACT. LOVEJOY FURTHER DISCLAIMS ALL LIABILITY FROM PERSONAL INJURY RELATING TO ITS PRODUCTS TO THE EXTENT PERMITTED BY LAW. BY ACCEPTANCE OF ANY OF LOVEJOY'S PRODUCTS, THE PURCHASER ASSUMES ALL LIABILITY FOR THE CONSEQUENCES ARISING FROM THEIR USE OR MISUSE.

This express warranty is the only warranty applicable to this transaction. *IT EXCLUDES ALL OTHER EXPRESS ORAL OR WRITTEN WARRANTIES AND ALL WARRANTIES IMPLIED BY LAW WITH RESPECT TO THE PRODUCTS, INCLUDING ANY WARRANTIES OF MERCHANTABILITY OR FITNESS FOR A PARTICULAR PURPOSE.*

Every claim under this warranty shall be deemed waived by the purchaser unless made in writing within one (1) year of the receipt of the products to which such claim relates. This warranty is void in the event that repairs are made by anyone other than Lovejoy without prior authorization from Lovejoy. No person, firm or corporation is authorized to assume for Lovejoy any other liability in connection with the sale of its products. No person, firm or corporation is authorized to modify or waive the terms of this Warranty unless done in writing and signed by a duly authorized agent of Lovejoy.

Note: Specifications are subject to change without notice, and without liability therefor.





# The Reinvention of the Gear Coupling



THE FPDA  
MEMBER



## Lovejoy, Inc. World Headquarters

2655 Wisconsin Avenue  
Downers Grove, IL 60515 U.S.A.  
Phone: 630-852-0500  
Fax: 630-852-2120  
info@lovejoy-inc.com  
www.lovejoy-inc.com

## R+L Hydraulics GmbH

Friedrichstrasse 6  
D-58791 Werdohl  
Germany  
Phone +49 (0) 23 39 / 5 09-0  
Fax +49 (0) 23 92 / 5 09-509  
info@rl-hydraulics.com  
www.rl-hydraulics.com

## Lovejoy Canada

171 Superior Boulevard  
Mississauga, Ontario  
Canada L5T 2L6  
Phone: 905-670-9421  
Fax: 905-670-4594  
lovejoycanada@lovejoy-inc.com  
www.lovejoy-inc.com

## Other Lovejoy Affiliates: Lovejoy Powder Metal Group

Manufacturer of made-to-order powder metal components  
www.lovejoy-inc.com

ISO 9001:2008 Certified

Your Authorized Lovejoy Distributor is:

