



STAINLESS REDUCER

STAINLESS Steel



Durable and long-lasting double enveloping gearing contained in a smooth and rounded stainless steel housing for easy cleaning.

STAINLESS STEEL DIAGRAM

Cone Drive's Stainless Steel Worm Gear Gearbox

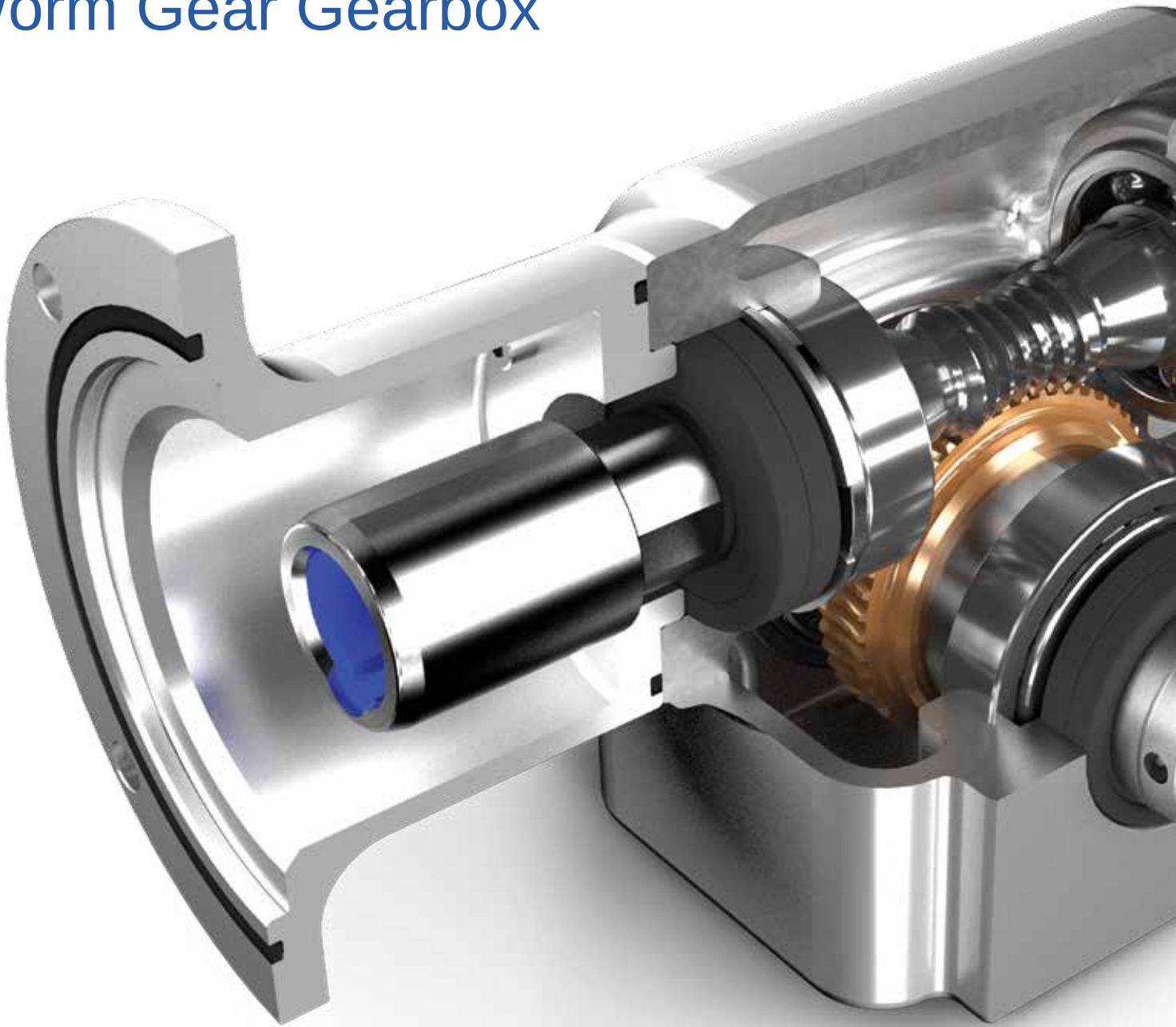

STAINLESS STEEL DIAGRAM

- 
- 1** Industry leading 5 year warranty
 - 2** Industry's only tested and rated IP-69K worm gear assembly
 - 3** Cone Drive true double-enveloping worm gearing offering 300% shock load and long durable life
 - 4** Non-fretting motor connection bushing to guarantee motor removal
 - 5** Double input bearings to properly and accurately align the motor to the input. Eliminates input leaks, allows for correct worm and gear mesh for longer gear and bearing life. No limitations with mounting positions
 - 6** Double input and output seals to prevent leaks or contamination in the gearbox
 - 7** Smooth housing to eliminate bacteria growth
 - 8** Manufactured complete in the USA

WHY STAINLESS STEEL GEARBOXES?

Cone Drive stainless steel gearboxes offer features which cannot be found in today's market. The anti-fretting motor input shaft connection allows for easy removal of the motor. Two bearings on the input shaft ensure proper motor alignment of the motor to the gearbox. This also helps to eliminate leaks and allows the gearbox to be mounted in any position. Smooth rounded surfaces help to eliminate free-standing water and prevent bacteria growth.

PRODUCT SPECIFICATIONS:

- **Sizes:** 39, 44, 50, 60, 76
- **Ancillary Options:** Output flange, side mount, base mounted feet
- **Motor Adaptation:** NEMA 56c through 180c
- **Input Options:** Solid or hollow output
- **Output Options:** Special bores or ratios available

DESIGNED TO HELP YOU MEET:

GOVERNMENT REGULATION

- IP 69K designed / tested / proven
- 3A Certified
- NSF Certified
- EHEDG Certification pending

IMPROVED UPTIME

- Non-fretting motor bushing for easy motor removal
- Double worm bearing support. Eliminates leaks by relying on worm alignment from the motor
- Double enveloping worm gearing: Multiple teeth in contact promotes longer life



AFFILIATIONS AND CERTIFICATIONS



IP 69K

The Cone Drive stainless steel worm gearbox is the only IP69K independently tested and rated gearbox.



Our stainless steel gearboxes come with an industry leading 5-year warranty.

Certifications



Pending Certifications



MARKETS / INDUSTRIES SERVED



Food Packaging & Processing

Cone Drive has extensive experience in the Food Packaging & Processing Industry and understands the numerous applications requiring power transmission products. We offer a large range of ready-made product lines suitable for application in a diverse array of industries. These product lines provide flexible configuration options with exceptionally quick availability. The universal designs are also customizable to incorporate features that benefit integration into your system architecture.

Food & Beverage Applications

- Rotary Filling
- Separators & Mixers
- Extractors
- Aseptic Filling

Meat & Poultry

Key Applications

- Skinning & De-boning
- Cutting
- Dicing
- Slicing
- Blending & Grinding
- Conveying



Fruits & Vegetables

Key Applications

- Sorters, Peelers, Splitters
- Corers, Pitters, De-stemmers
- Slicers & Dicers
- Blanchers & Cookers
- Conveying



Seafood Processing

Key Applications

- Heading & Gutting
- Battering, Breading & Frying
- Conveying



Dairy

Key Applications

- Pasteurizers & Homogenizers
- Conveying Systems
- Churning



Pharmaceutical and Chemical

Key Applications

- Dry granulator mixers
- Wet chemical mixers
- Fluid fill stations
- Conveyor systems
- Blister packaging machines
- Cartoning equipment



CONFIGURATOR TOOL

<http://www.conetools.com/content/RedirectPage.aspx>

Code	Values
F	Series
044	Size of Unit
0	Revision
7.5	Ratio
B	Unit to allow Fitting of Motor with Double Extension - Inch
F	Std Unit With Output Flange on Left
C	Metric Solid Single Extension
T	NEMA 56C Motor Flange
04	Single Extended Solid Output Left
H	Foundation Hole Plugs

Select format to create the CAD files for download

Select 3D file format:

Select 2D file format:

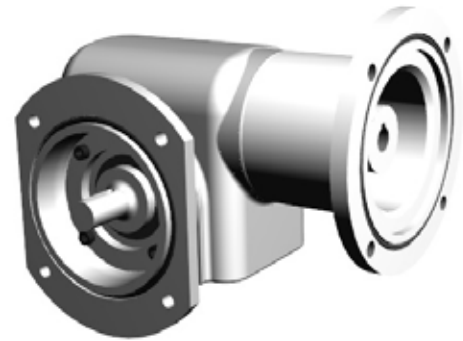

October 09, 2015

Product Code (15 Digit) – F03907.5AWCV01C

Specifications	
Size Of Unit	39
Nominal Ratio	7.5
Input Speed	1150 RPM
Output Speed	153 RPM
Input Power Mechanical	1.39 HP
Input Power Thermal	1.39 HP
Output Torque	521 lb-in
Efficiency	91%

Code Explanation	
F	Series
039	Size of Unit
0	Revision
7.5	Ratio
A	Unit to allow Fitting of Motor
W	Standard Unit (No Attachments)
C	Metric Solid Single Extension
V	NEMA 143/145TC Motor Flange
01	Single Extended Solid Output Left
C	Viton seals

Note: If you plan to place an order or obtain a quote for this unit, please email or fax this specification document along with your request.



Cone Drive's stainless steel reducers are designed for sterile manufacturing environments. The smooth housings allow for easy cleaning and bacteria free surfaces.



Warranty

- | FEATURES | INCH OR METRIC SHAFTS |
|---|------------------------------------|
| • PROTECTION TYPE IP69K | • DOUBLE SEAL INPUT & OUTPUT SEALS |
| • LIFE-TIME LUBRICATION WITH FOOD-GRADE OIL | • ASEPTIC DESIGN |
| • DOUBLE-ENVELOPING WORM GEARING | • NON-FRETTING MOTOR CONNECTION |

SPECS	1.54", 1.75", 1.97", 2.38", 3.00"
CENTER DISTANCES	Up to 184TC frame
NEMA FRAMES	Up to 6,660 lb-in
OUTPUT TORQUE	From 5:1 to 60:1, single reduction
GEAR RATIOS	Solid or Hollow Shaft in inch or metric sizes
OUTPUT OPTIONS	316 Stainless Steel
MATERIAL	

Cone Drive Operations, Inc.
240 East 12th Street
Traverse City, MI 49684, USA

T +1 888 994 2663
E orders@conedrive.com
W www.conedrive.com



STAINLESS STEEL GEARING SOLUTIONS

Sales: 1-888-994-2663
Sales Fax: 1-888-907-2663
Traverse City, MI. 49685

CONEDRIVE.COM

Cone Drive reserves the right to improve or change product design and specifications without notice.

STAINLESS STEEL NEMA 15-DIGIT CODE

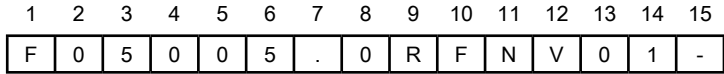

1 - SERIES

F

2 - 4 Size

0	3	9
0	4	4
0	5	0
0	6	0
0	7	6

5 - Revision Level

0

6, 7, 8 - Exact Ratio

5	.	0
7	.	5
1	0	.
1	5	.
2	0	.
2	5	.
3	0	.
4	0	.
5	0	.
6	0	.

9 - Input Type

- A - Unit to Allow Fitting of Motor
- B - Unit to Allow Fitting of Motor with Double Extended (inch)
- C - Unit to Allow Fitting of Motor with Double Extended (metric)
- R - Reducer Unit - (Inch Input)
- M - Reducer Unit - (Metric Input)
- T - Reducer Unit (Double Extended Inch Input)
- N - Reducer Unit (Double Extended Metric Input)

10 - Output Shaft

- W - Standard Unit (No Attachments)
- F - Standard Unit Output Flange on Left **
- H - Standard Unit Output Flange on Right **
- D - Standard Unit with Machined Face on Left **
- Y - Standard Unit with Machined Face on Right **
- B - Standard Unit with Base Mounted Feet
- V - Standard Unit with Base Mounted Feet and Machined Face on Left**
- J - Standard Unit with Base Mounted Feet and Machined Face on Right**

** Looking into input shaft with unit in Input over output mounting position

15 - Special Options
(See Table below)

13 - 14 Assembly Position
(input over output viewed from driven input - motorized end of housing)

Single Extended Input with:

- 0 1 - Single extended solid output - left
- 0 2 - Single extended solid output - right
- 0 3 - Hollow or double ext. solid output
- 3 L - Shrink disc hollow shaft - left
- 3 R - Shrink disc hollow shaft - right
- 4 L - Shrink disc hollow shaft with cover - left
- 4 R - Shrink disc hollow shaft with cover - right
- 5 L - Hollow shaft with cover - left
- 5 R - Hollow shaft with cover - right

Double Extended Input with:

- 0 4 - Single extended solid output - left
- 0 6 - Single extended solid output - right
- 0 6 - Hollow or double ext. solid output
- 6 L - Shrink disc hollow shaft - left
- 6 R - Shrink disc hollow shaft - right
- 7 L - Shrink disc hollow shaft with cover - left
- 7 R - Shrink disc hollow shaft with cover - right
- 8 L - Hollow shaft with cover - left
- 8 R - Hollow shaft with cover - right

12 - Motor Frame Size

- - Reducer Unit
 - T - NEMA 58C Motor Flange
 - V - NEMA 143/145TC Motor Flange
 - X - NEMA 182/184TC Motor Flange
- (Custom motor adaptation available upon request)

11 - Output Shaft**

- N - Inch Single Extension
- P - Inch Double Extension
- * - Inch Hollow Shaft (*See chart for available sizes)
- Q - Inch Reduced Diameter Sgl. Ext. (sizes 44, 50 & 76 only)
- R - Inch Reduced Diameter Dbl. Ext. (sizes 44, 50 & 76 only)
- C - Metric Single Extension
- D - Metric Double Extension
- H - Metric Hollow Sheet
- L - Inch Shrink Disc Hollow Bore
- K - Metric Shrink Disc Hollow Bore

Column 15 Entry - Special Feature Options

Column 15 Entry	Low Backlash	Viton Seals	Foundation Hole Plugs
-			
A	•		
C		•	
F	•	•	
H			•
J	•		•
L		•	•
P	•	•	•

Column 11 Entry - Inch Hollow Bore Sizes

	F039	F044	F050	F060	F076
0.625	E				
0.875	F	E			
1.000	A	F	E	E	
1.125		G	F	F	
1.188		--	G	G	
1.250		A	J	J	
1.438			A	A	E
1.750					F
1.938					G
2.188					A

GEOMETRIES / SPECIFICATIONS for Size F039

Solid Output Shaft Version

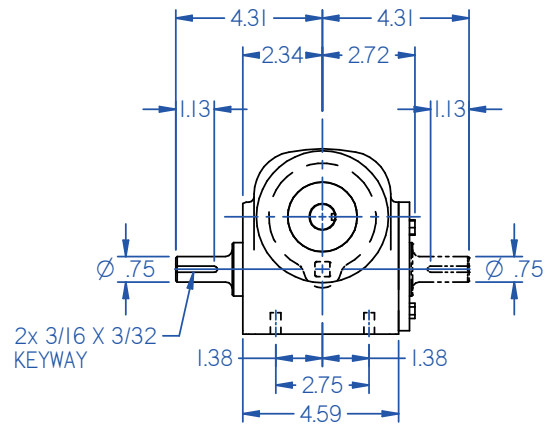
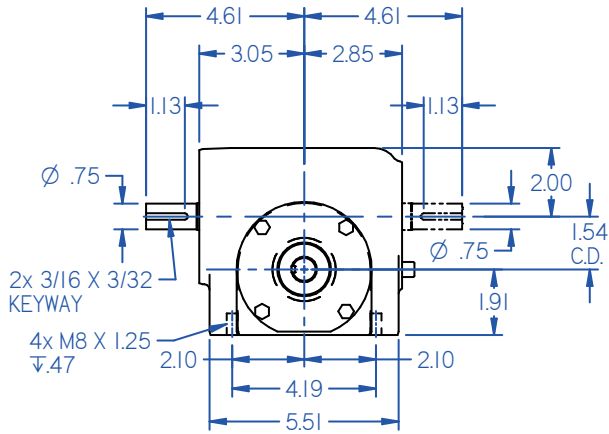

INCH SOLID		METRIC SOLID	
SHAFT DIA.	KEY WAY	SHAFT DIA.	KEY WAY
0.750	3/16 x 3/32	18	6.0 x 3.0

APPROX. SHIPPING WT: 25.8 lbs.

Output Flange Version

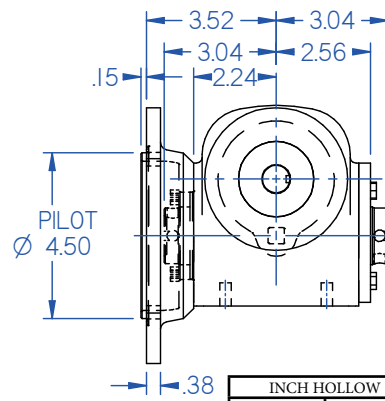
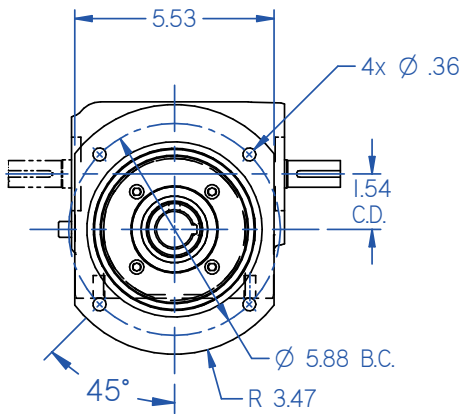

INCH HOLLOW		METRIC HOLLOW	
SHAFT DIA.	KEY WAY	SHAFT DIA.	KEY WAY
0.625	3/16 x 3/32	19	6.0 x 3.0
0.875	3/16 x 3/32		
1.000	1/4 x 1/8		

APPROX. SHIPPING WT: 25.6 lbs.

Foot Mount Version

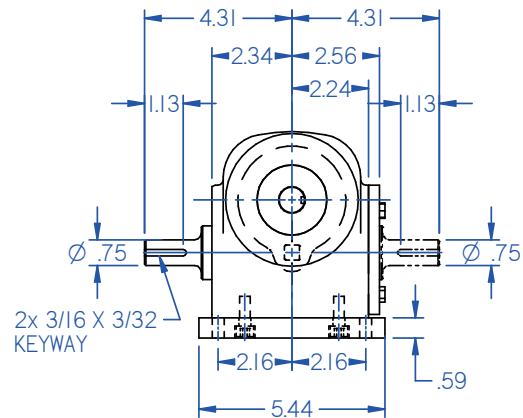
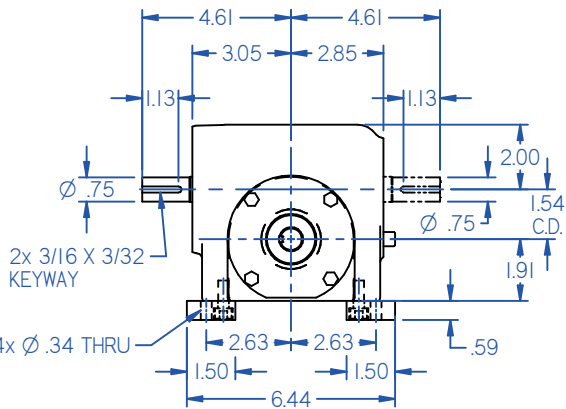

APPROX. SHIPPING WT: 28.2 lbs.

ALL DIMENSIONS ARE IN INCHES UNLESS SPEC IED OTHERWISE STANDARD INCH SHAFTS SHOWN, ALTERNATIVES INCLUDING METRIC ARE OUTLINED IN CORRESPONDING TABLE SOLID SHAFT KEYS PROVIDED

GEOMETRIES / SPECIFICATIONS for Size F039

Hollow Output Version

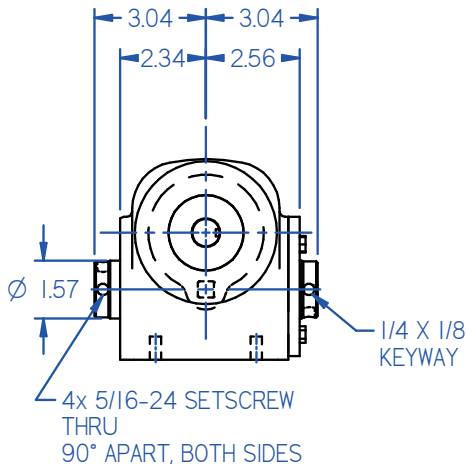

APPROX. SHIPPING WT: 23.4 lbs.

Side Mount Version

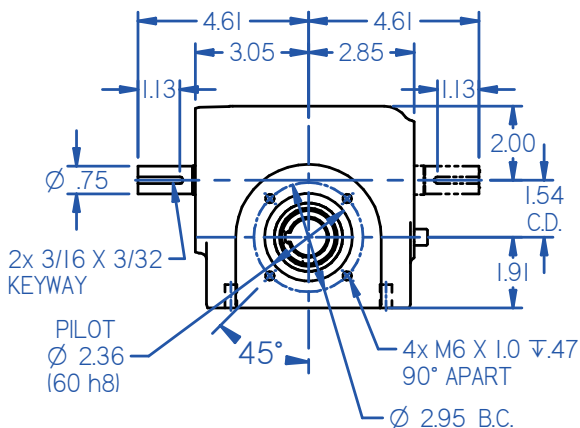

APPROX. SHIPPING WT: 23.1 lbs.

Motor Adapter Version

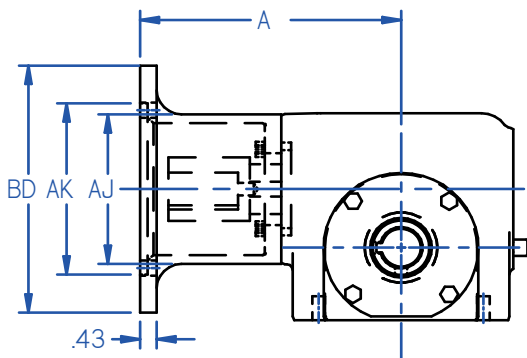

APPROX. SHIPPING WT: 28.0 lbs.

NEMA	A	BD	AK	AJ
56C/140TC	6.64	6.50	4.50	5.88
180TC	7.43	9.00	8.50	7.25

Overhung Load Capacity: 600 Lbs (solid or hollow shaft)
(Capacity is based on load acting at the center of the keyway for the solid output shaft).

RATIO	CAPACITY	1150 RPM INPUT	1750 RPM INPUT
		F039	F039
5	Input Power HP (mech)	1.88	2.37
	Input Power HP (thermal)	1.88	2.37
	Output Torque lb-in (mech)	475	392
	Efficiency	92	92
7.5	Input Power HP (mech)	1.58	2.01
	Input Power HP (thermal)	1.58	2.01
	Output Torque lb-in (mech)	592	494
	Efficiency	91	91
10	Input Power HP (mech)	1.34	1.70
	Input Power HP (thermal)	1.34	1.70
	Output Torque lb-in (mech)	658	552
	Efficiency	90	90
15	Input Power HP (mech)	1.09	1.40
	Input Power HP (thermal)	1.09	1.40
	Output Torque lb-in (mech)	790	665
	Efficiency	88	88
20	Input Power HP (mech)	0.84	1.07
	Input Power HP (thermal)	0.84	1.07
	Output Torque lb-in (mech)	770	657
	Efficiency	84	85
25	Input Power HP (mech)	0.93	0.87
	Input Power HP (thermal)	0.93	0.87
	Output Torque lb-in (mech)	877	655
	Efficiency	84	84
30	Input Power HP (mech)	0.57	0.73
	Input Power HP (thermal)	0.57	0.73
	Output Torque lb-in (mech)	743	627
	Efficiency	80	73
40	Input Power HP (mech)	0.43	0.55
	Input Power HP (thermal)	0.43	0.55
	Output Torque lb-in (mech)	710	599
	Efficiency	76	76
50	Input Power HP (mech)	0.34	0.44
	Input Power HP (thermal)	0.34	0.44
	Output Torque lb-in (mech)	684	577
	Efficiency	73	73
60	Input Power HP (mech)	0.29	0.37
	Input Power HP (thermal)	0.29	0.37
	Output Torque lb-in (mech)	658	555
	Efficiency	70	70

GEOMETRIES / SPECIFICATIONS for Size F044

Solid Output Shaft Version

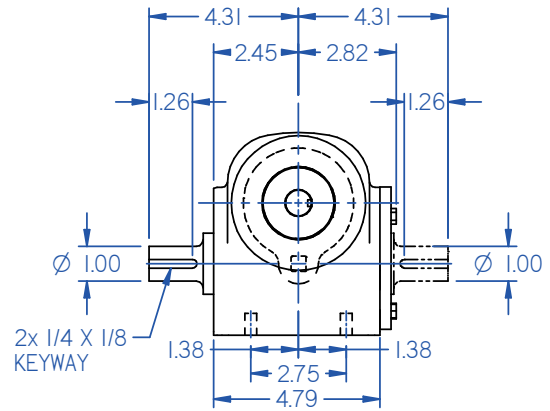
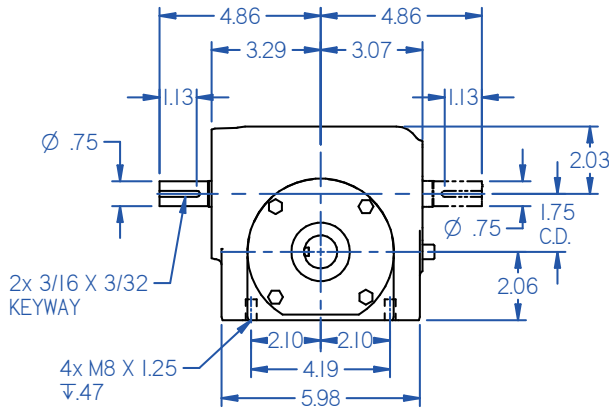

INCH SOLID		METRIC SOLID	
SHAFT DIA.	KEY WAY	SHAFT DIA.	KEY WAY
0.875	3/16 x 3/32	20	6.0 x 3.0
1.000	1/4 x 1/8		

APPROX. SHIPPING WT: 29.8 lbs.

Output Flange Version

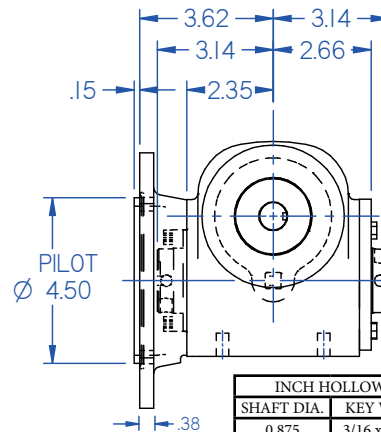
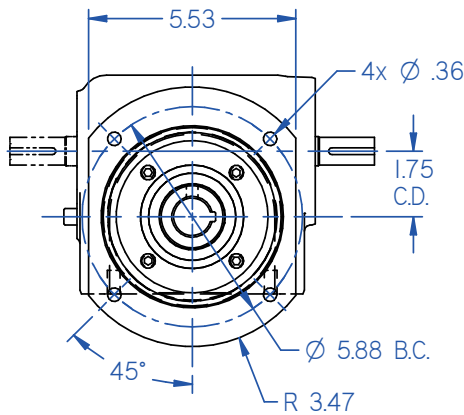

INCH HOLLOW		METRIC HOLLOW	
SHAFT DIA.	KEY WAY	SHAFT DIA.	KEY WAY
0.875	3/16 x 3/32	20	6.0 x 3.0
1.000	1/4 x 1/8		
1.125	1/4 x 1/8		
1.250	1/4 x 1/8		

APPROX. SHIPPING WT: 29.3 lbs.

Foot Mount Version

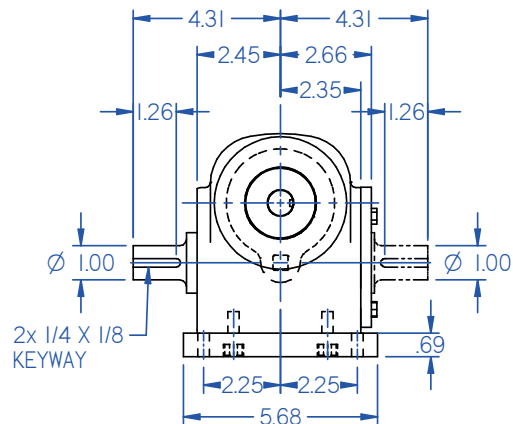
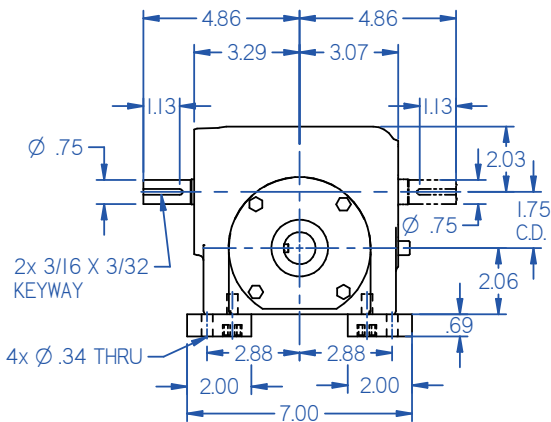

APPROX. SHIPPING WT: 34.0 lbs.

ALL DIMENSIONS ARE IN INCHES UNLESS SPEC IED OTHERWISE STANDARD INCH SHAFTS SHOWN, ALTERNATIVES INCLUDING METRIC ARE OUTLINED IN CORRESPONDING TABLE SOLID SHAFT KEYS PROVIDED

GEOMETRIES / SPECIFICATIONS for Size F044

Hollow Output Version

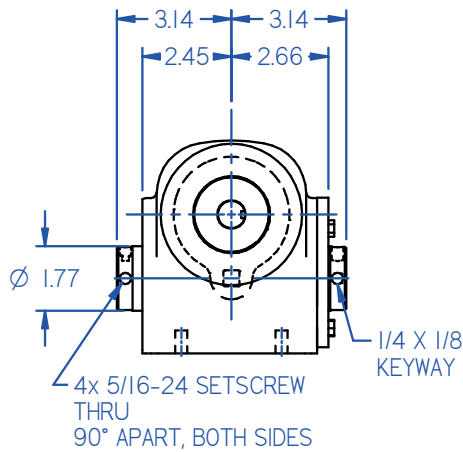

APPROX. SHIPPING WT: 27.9 lbs.

Side Mount Version

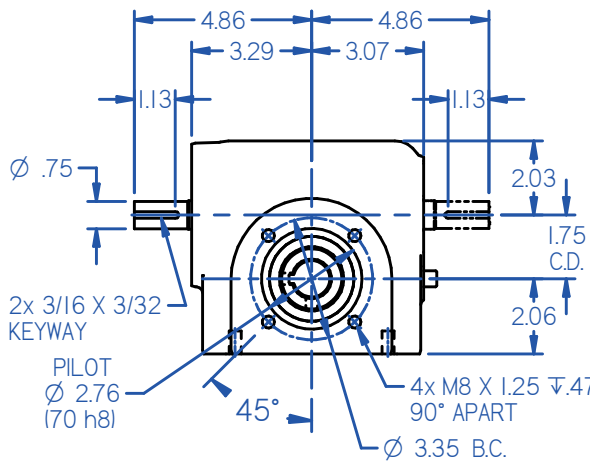

APPROX. SHIPPING WT: 25.3 lbs.

Motor Adapter Version

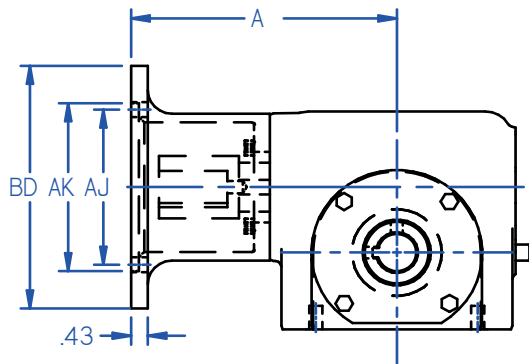

APPROX. SHIPPING WT: 33.2 lbs.

NEMA	A	BD	AK	AJ
56C/140TC	6.88	6.50	4.50	5.88
180TC	7.68	9.00	8.50	7.25

Overhung Load Capacity: 1,100 Lbs (solid or hollow shaft)
(Capacity is based on load acting at the center of the keyway for the solid output shaft).

RATIO	CAPACITY	1150 RPM INPUT	1750 RPM INPUT
		F044	F044
5	Input Power HP (mech)	2.61	3.28
	Input Power HP (thermal)	2.61	2.90
	Output Torque lb-in (mech)	658	544
	Efficiency	92	92
7.5	Input Power HP (mech)	2.20	2.79
	Input Power HP (thermal)	2.20	2.58
	Output Torque lb-in (mech)	821	685
	Efficiency	91	91
10	Input Power HP (mech)	1.85	2.36
	Input Power HP (thermal)	1.85	2.32
	Output Torque lb-in (mech)	912	765
	Efficiency	90	90
15	Input Power HP (mech)	1.40	1.80
	Input Power HP (thermal)	1.40	1.80
	Output Torque lb-in (mech)	1012	855
	Efficiency	88	88
20	Input Power HP (mech)	1.10	1.40
	Input Power HP (thermal)	1.10	1.40
	Output Torque lb-in (mech)	1012	857
	Efficiency	84	85
25	Input Power HP (mech)	0.91	1.10
	Input Power HP (thermal)	0.91	1.10
	Output Torque lb-in (mech)	1046	832
	Efficiency	84	84
30	Input Power HP (mech)	0.78	1.01
	Input Power HP (thermal)	0.78	1.01
	Output Torque lb-in (mech)	1029	869
	Efficiency	80	80
40	Input Power HP (mech)	0.59	0.76
	Input Power HP (thermal)	0.59	0.76
	Output Torque lb-in (mech)	984	831
	Efficiency	76	76
50	Input Power HP (mech)	0.47	0.90
	Input Power HP (thermal)	0.47	0.86
	Output Torque lb-in (mech)	948	800
	Efficiency	73	73
60	Input Power HP (mech)	0.40	0.51
	Input Power HP (thermal)	0.40	0.51
	Output Torque lb-in (mech)	912	770
	Efficiency	70	70

GEOMETRIES / SPECIFICATIONS for Size F050

Solid Output Shaft Version

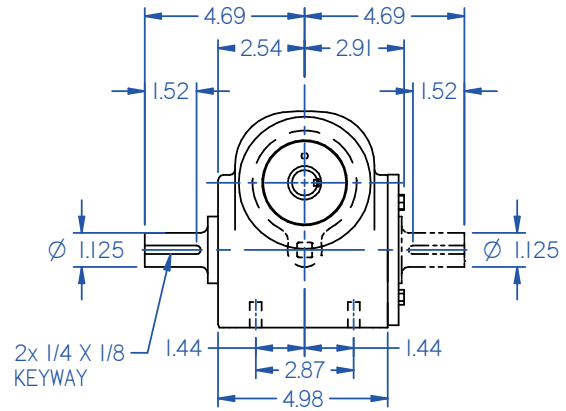
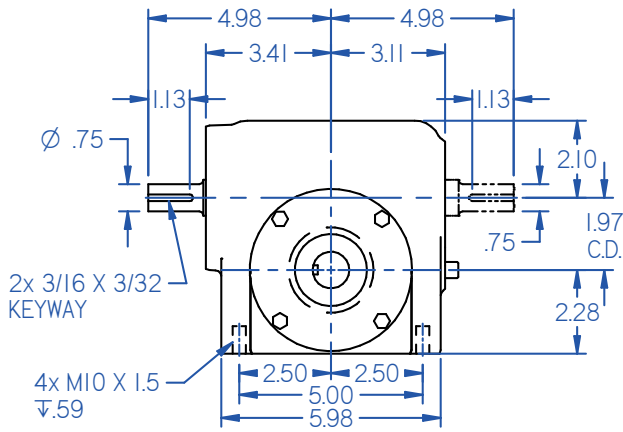

INCH SOLID		METRIC SOLID	
SHAFT DIA.	KEY WAY	SHAFT DIA.	KEY WAY
1.000	1/4 x 1/8	25	8.0 x 4.0
1.125	1/4 x 1/8		

APPROX. SHIPPING WT: 31.6 lbs.

Output Flange Version

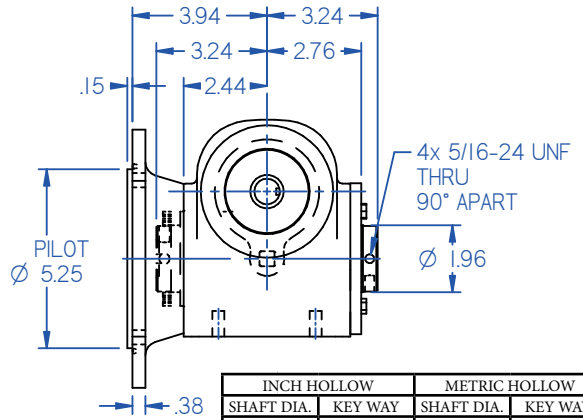
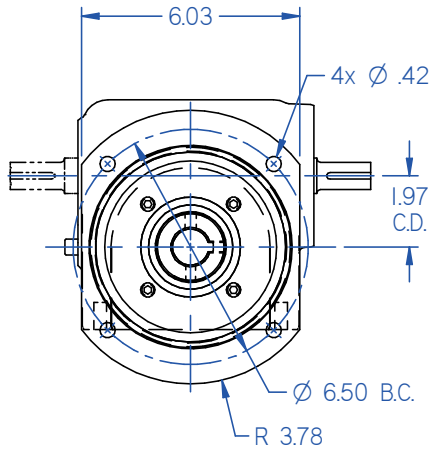

INCH HOLLOW		METRIC HOLLOW	
SHAFT DIA.	KEY WAY	SHAFT DIA.	KEY WAY
0.875	1/4 x 1/8	25	8.0 x 4.0
1.125	1/4 x 1/8		
1.188	1/4 x 1/8		
1.250	1/4 x 1/8		
1.438	1/4 x 1/8		

APPROX. SHIPPING WT: 32.8 lbs.

Foot Mount Version

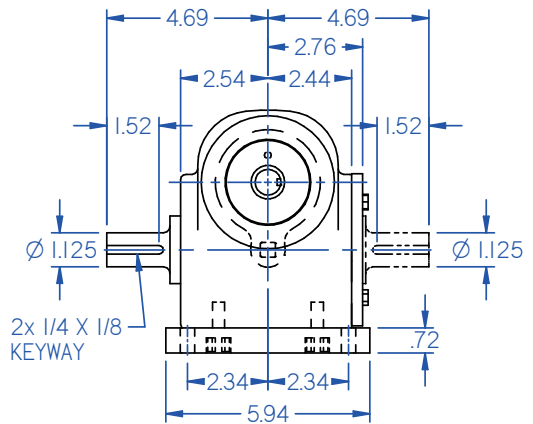
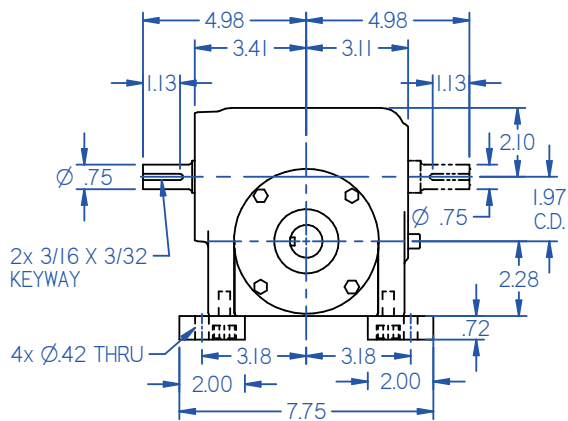

APPROX. SHIPPING WT: 36.2 lbs.

ALL DIMENSIONS ARE IN INCHES UNLESS SPEC IED OTHERWISE STANDARD INCH SHAFTS SHOWN, ALTERNATIVES INCLUDING METRIC ARE OUTLINED IN CORRESPONDING TABLE SOLID SHAFT KEYS PROVIDED

GEOMETRIES / SPECIFICATIONS for Size F050

Hollow Output Version

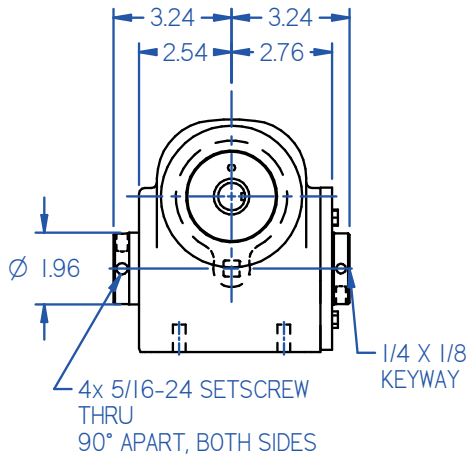

APPROX. SHIPPING WT: 28.7 lbs.

Side Mount Version

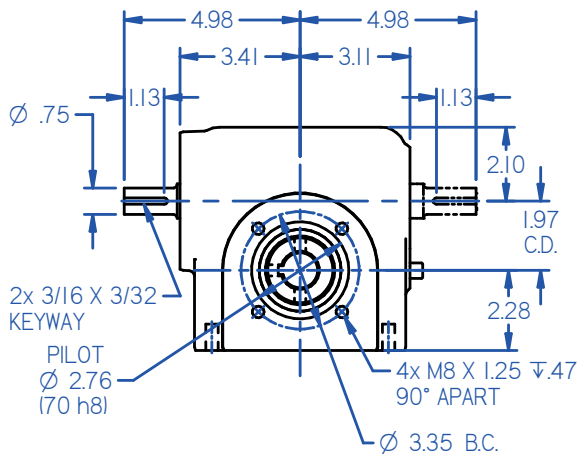

APPROX. SHIPPING WT: 28.4 lbs.

Motor Adapter Version

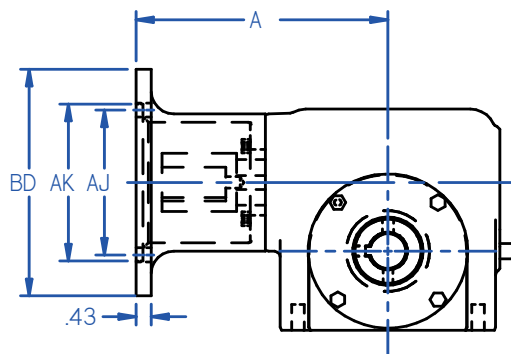

APPROX. SHIPPING WT: 36.1 lbs.

NEMA	A	BD	AK	AJ
56C/140TC	6.99	6.50	4.50	5.88
180TC	7.80	9.00	8.50	7.25

Overhung Load Capacity: 1,200 Lbs (solid or hollow shaft)
(Capacity is based on load acting at the center of the keyway for the solid output shaft).

RATIO	CAPACITY	1150 RPM INPUT	1750 RPM INPUT
		F050	F050
5	Input Power HP (mech)	3.49	4.38
	Input Power HP (thermal)	2.96	2.96
	Output Torque lb-in (mech)	879	726
	Efficiency	92	92
7.5	Input Power HP (mech)	2.93	3.72
	Input Power HP (thermal)	2.63	2.63
	Output Torque lb-in (mech)	1097	915
	Efficiency	91	91
10	Input Power HP (mech)	2.47	3.16
	Input Power HP (thermal)	2.37	2.37
	Output Torque lb-in (mech)	1219	1022
	Efficiency	90	90
15	Input Power HP (mech)	2.02	2.59
	Input Power HP (thermal)	1.98	1.98
	Output Torque lb-in (mech)	1463	1230
	Efficiency	88	88
20	Input Power HP (mech)	1.55	1.99
	Input Power HP (thermal)	1.48	1.48
	Output Torque lb-in (mech)	1426	1217
	Efficiency	84	84
25	Input Power HP (mech)	1.25	1.60
	Input Power HP (thermal)	1.25	1.48
	Output Torque lb-in (mech)	1438	1212
	Efficiency	84	84
30	Input Power HP (mech)	1.05	1.34
	Input Power HP (thermal)	1.05	1.19
	Output Torque lb-in (mech)	1375	1160
	Efficiency	80	80
40	Input Power HP (mech)	0.79	1.01
	Input Power HP (thermal)	0.79	0.99
	Output Torque lb-in (mech)	1315	1110
	Efficiency	76	76
50	Input Power HP (mech)	0.63	0.81
	Input Power HP (thermal)	0.63	0.81
	Output Torque lb-in (mech)	1266	1069
	Efficiency	73	73
60	Input Power HP (mech)	0.53	0.68
	Input Power HP (thermal)	0.53	0.68
	Output Torque lb-in (mech)	1219	1028
	Efficiency	70	70

GEOMETRIES / SPECIFICATIONS for Size F060

Solid Output Shaft Version

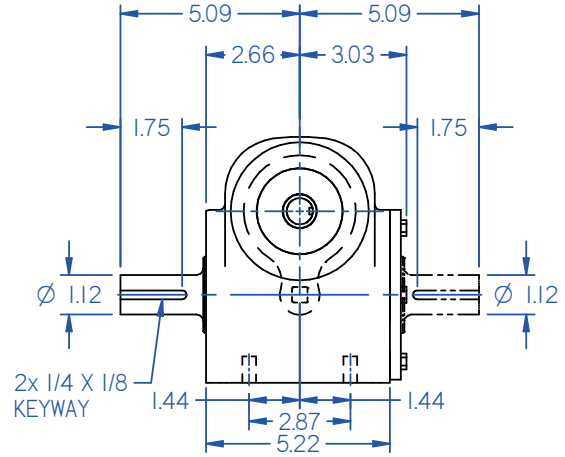
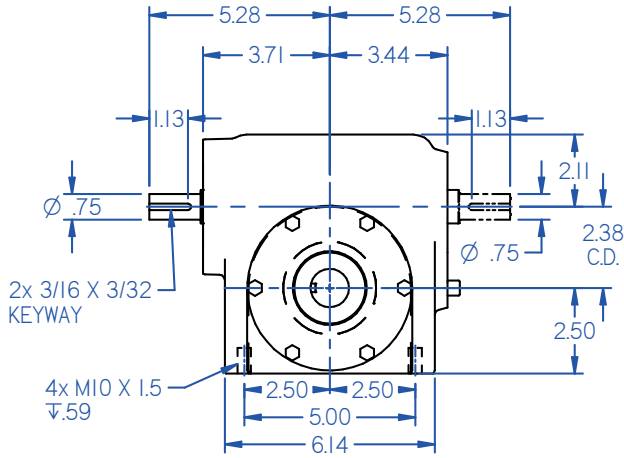

INCH SOLID		METRIC SOLID	
SHAFT DIA.	KEY WAY	SHAFT DIA.	KEY WAY
1.125	1/4 x 1/8	28	8.0 x 4.0

APPROX. SHIPPING WT: 39.9 lbs.

Output Flange Version

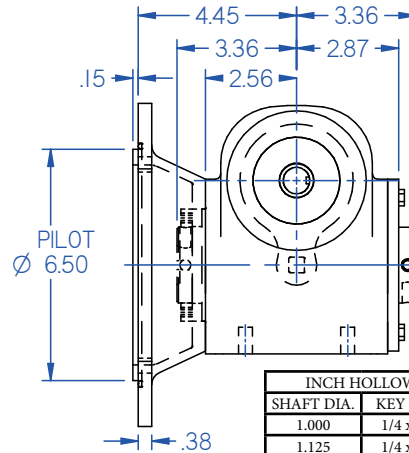
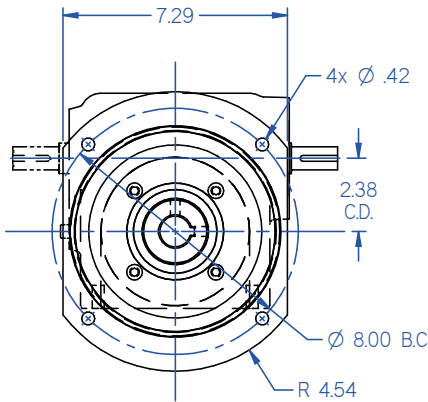

INCH HOLLOW		METRIC HOLLOW	
SHAFT DIA.	KEY WAY	SHAFT DIA.	KEY WAY
1.000	1/4 x 1/8	28	8.0 x 4.0
1.125	1/4 x 1/8		
1.188	1/4 x 1/8		
1.250	1/4 x 1/8		
1.438	1/4 x 1/8		

APPROX. SHIPPING WT: 41.4 lbs.

Foot Mount Version

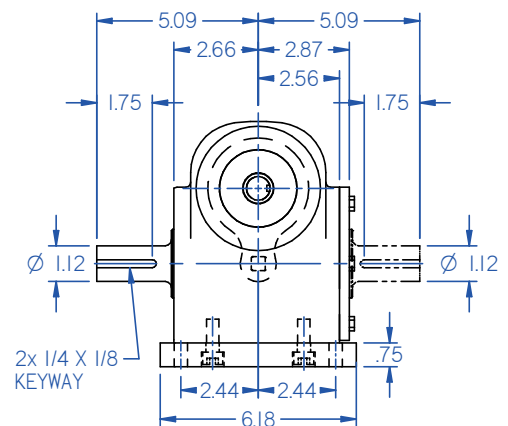
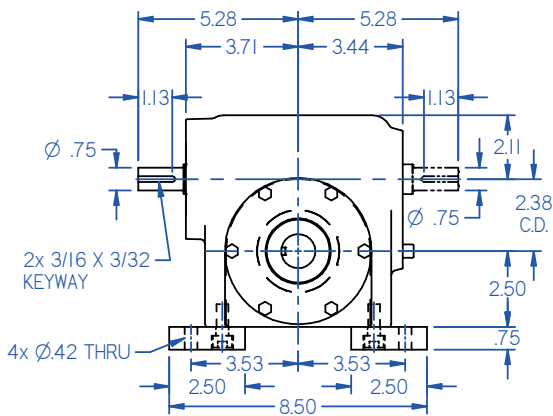

APPROX. SHIPPING WT: 45.7 lbs.

ALL DIMENSIONS ARE IN INCHES UNLESS SPEC IED OTHERWISE STANDARD INCH SHAFTS SHOWN, ALTERNATIVES INCLUDING METRIC ARE OUTLINED IN CORRESPONDING TABLE SOLID SHAFT KEYS PROVIDED

GEOMETRIES / SPECIFICATIONS for Size F060

Hollow Output Version

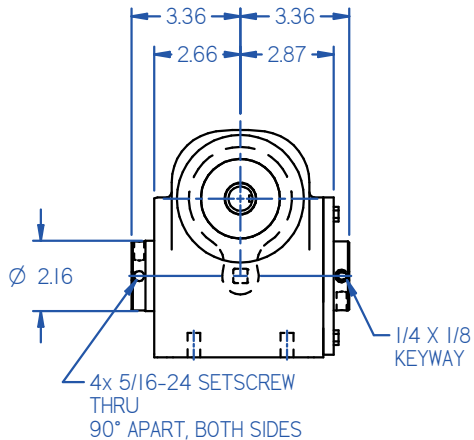

APPROX. SHIPPING WT: 36.3 lbs.

Overhung Load Capacity: 1,800 Lbs (solid or hollow shaft)
(Capacity is based on load acting at the center of the keyway for the solid output shaft).

Side Mount Version

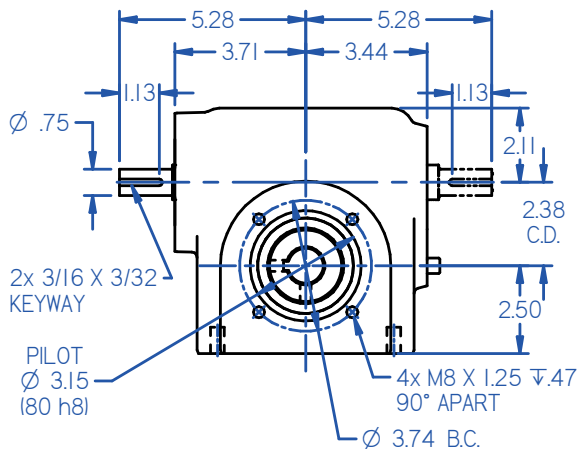

APPROX. SHIPPING WT: 35.9 lbs.

Motor Adapter Version

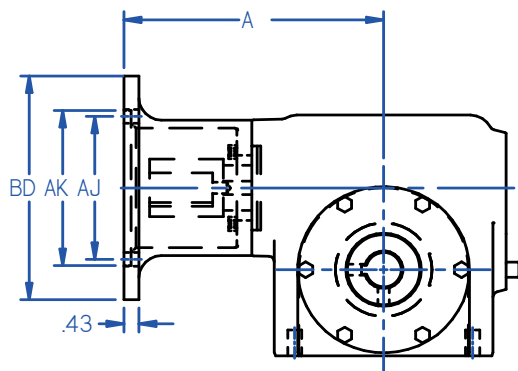

APPROX. SHIPPING WT: 45.6 lbs.

NEMA	A	BD	AK	AJ
56C/140TC	7.29	6.50	4.50	5.88
180TC	8.10	9.00	8.50	7.25

RATIO	CAPACITY	1150 RPM INPUT	1750 RPM INPUT
		F060	F060
5	Input Power HP (mech)	5.59	7.01
	Input Power HP (thermal)	3.04	3.04
	Output Torque lb-in (mech)	1410	1160
	Efficiency	92	92
7.5	Input Power HP (mech)	4.72	5.93
	Input Power HP (thermal)	2.70	2.70
	Output Torque lb-in (mech)	1765	1457
	Efficiency	91	91
10	Input Power HP (mech)	3.85	5.01
	Input Power HP (thermal)	2.43	2.43
	Output Torque lb-in (mech)	1898	1624
	Efficiency	90	90
15	Input Power HP (mech)	2.70	3.40
	Input Power HP (thermal)	2.03	2.03
	Output Torque lb-in (mech)	1952	1616
	Efficiency	88	88
20	Input Power HP (mech)	2.10	2.65
	Input Power HP (thermal)	1.52	1.62
	Output Torque lb-in (mech)	1933	1622
	Efficiency	84	85
25	Input Power HP (mech)	1.65	2.10
	Input Power HP (thermal)	1.52	1.52
	Output Torque lb-in (mech)	1898	1588
	Efficiency	84	84
30	Input Power HP (mech)	1.50	1.90
	Input Power HP (thermal)	1.22	1.22
	Output Torque lb-in (mech)	1972	1642
	Efficiency	80	80
40	Input Power HP (mech)	1.15	1.50
	Input Power HP (thermal)	1.01	1.01
	Output Torque lb-in (mech)	1915	1642
	Efficiency	76	76
50	Input Power HP (mech)	0.95	1.20
	Input Power HP (thermal)	0.90	0.90
	Output Torque lb-in (mech)	1900	1577
	Efficiency	73	73
60	Input Power HP (mech)	0.83	1.08
	Input Power HP (thermal)	0.81	0.81
	Output Torque lb-in (mech)	1910	1631
	Efficiency	70	70

GEOMETRIES / SPECIFICATIONS for Size F076

Solid Output Shaft Version

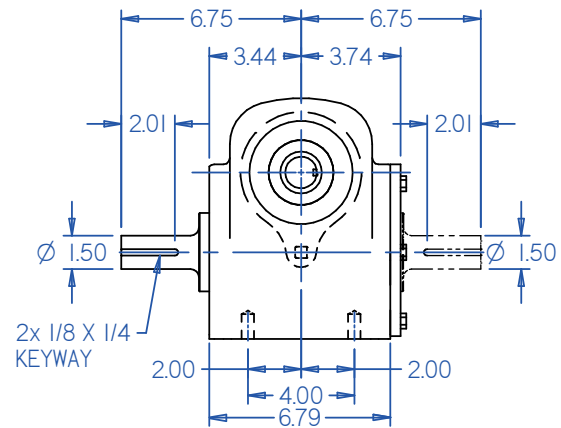
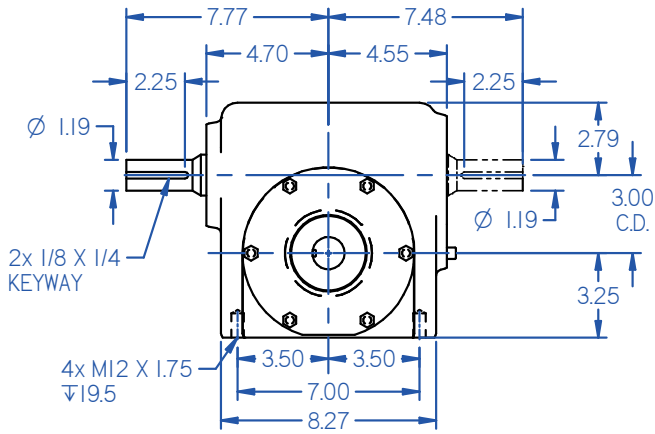

INCH SOLID		METRIC SOLID	
SHAFT DIA.	KEY WAY	SHAFT DIA.	KEY WAY
1.250	1/4 x 1/8	35	10 x 4.4
1.500	3/8 x 3/16		

APPROX. SHIPPING WT: 87.4 lbs.

Output Flange Version

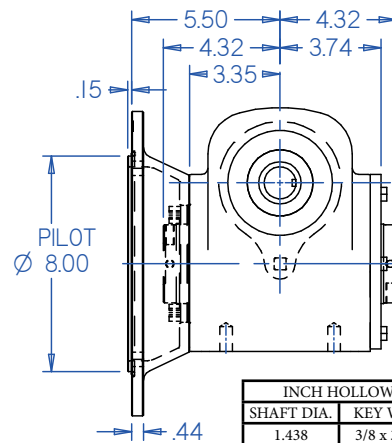
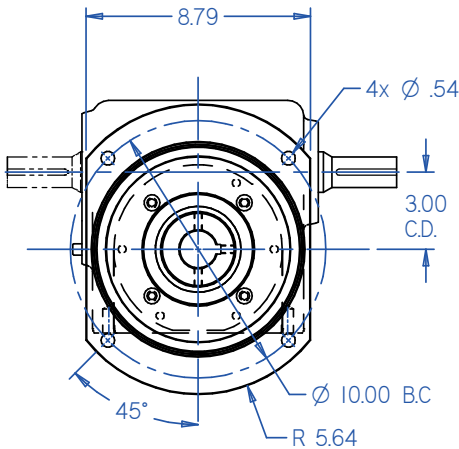

INCH HOLLOW		METRIC HOLLOW	
SHAFT DIA.	KEY WAY	SHAFT DIA.	KEY WAY
1.438	3/8 x 3/16	35	10 x 4.4
1.750	3/8 x 3/16		
1.938	1/2 x 1/4		
2.188	1/2 x 1/4		

APPROX. SHIPPING WT: 89.3 lbs.

Foot Mount Version

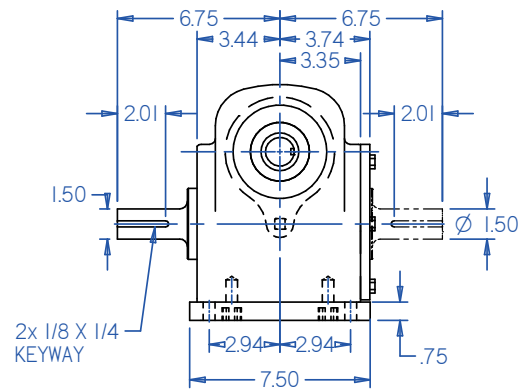
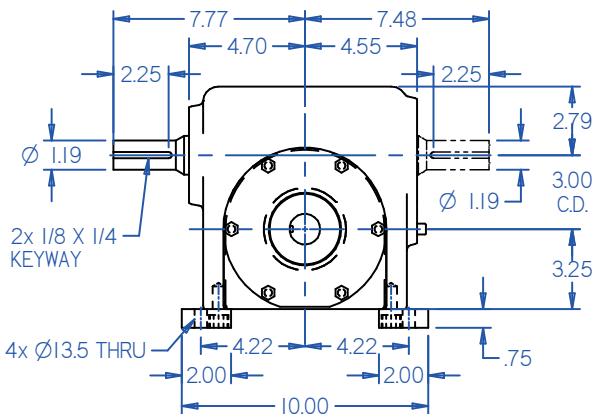

APPROX. SHIPPING WT: 81.6 lbs.

ALL DIMENSIONS ARE IN INCHES UNLESS SPEC IED OTHERWISE STANDARD INCH SHAFTS SHOWN, ALTERNATIVES INCLUDING METRIC ARE OUTLINED IN CORRESPONDING TABLE SOLID SHAFT KEYS PROVIDED

GEOMETRIES / SPECIFICATIONS for Size F076

Hollow Output Version

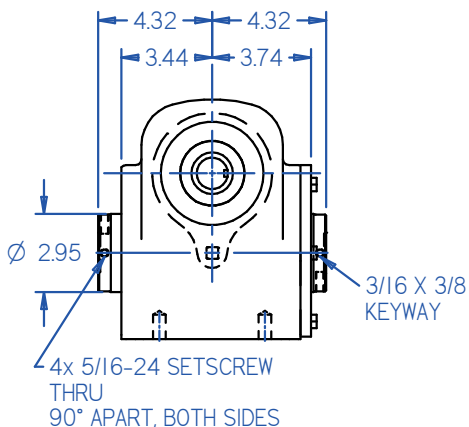

APPROX. SHIPPING WT: 78.9 lbs.

Side Mount Version

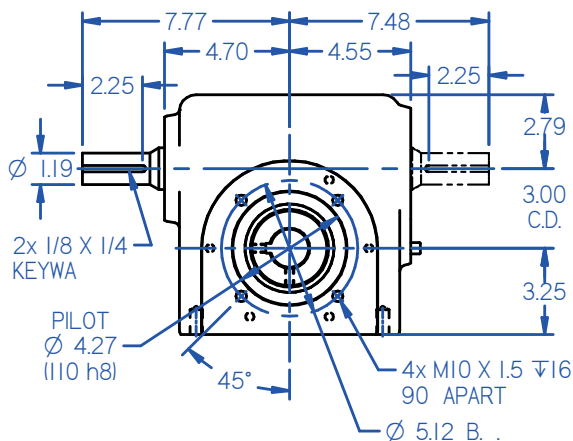

APPROX. SHIPPING WT: 77.9 lbs.

Motor Adapter Version

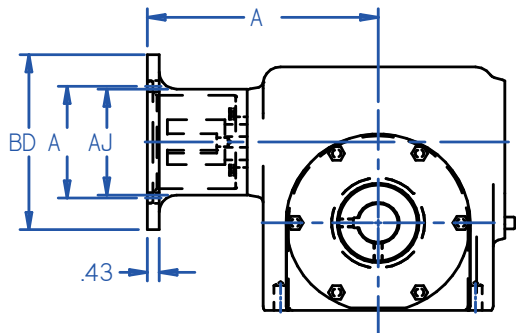

APPROX. SHIPPING WT: 86.4 lbs.

NEMA	A	BD	AK	AJ
56C/140TC	8.29	6.50	4.50	5.88
180TC	9.09	9.00	8.50	7.25

Overhung Load Capacity: 2,300 Lbs (solid or hollow shaft)
(Capacity is based on load acting at the center of the keyway for the solid output shaft).

RATIO	CAPACITY	1150 RPM INPUT	1750 RPM INPUT
		F076	F076
5	Input Power HP (mech)	10.80	13.60
	Input Power HP (thermal)	3.48	3.48
	Output Torque lb-in (mech)	2726	2252
	Efficiency	92	92
7.5	Input Power HP (mech)	9.32	11.70
	Input Power HP (thermal)	3.09	3.09
	Output Torque lb-in (mech)	3485	2867
	Efficiency	91	91
10	Input Power HP (mech)	8.02	10.00
	Input Power HP (thermal)	2.78	2.78
	Output Torque lb-in (mech)	3953	3249
	Efficiency	90	90
15	Input Power HP (mech)	6.00	7.50
	Input Power HP (thermal)	2.32	2.32
	Output Torque lb-in (mech)	4339	3564
	Efficiency	88	88
20	Input Power HP (mech)	4.60	5.90
	Input Power HP (thermal)	1.74	1.85
	Output Torque lb-in (mech)	4234	3611
	Efficiency	84	85
25	Input Power HP (mech)	3.75	4.80
	Input Power HP (thermal)	1.74	1.74
	Output Torque lb-in (mech)	4314	3629
	Efficiency	84	84
30	Input Power HP (mech)	3.42	4.28
	Input Power HP (thermal)	1.39	1.39
	Output Torque lb-in (mech)	4500	3702
	Efficiency	80	80
40	Input Power HP (mech)	2.58	3.23
	Input Power HP (thermal)	1.16	1.16
	Output Torque lb-in (mech)	4299	3532
	Efficiency	76	76
50	Input Power HP (mech)	2.07	2.59
	Input Power HP (thermal)	1.03	1.03
	Output Torque lb-in (mech)	4140	3407
	Efficiency	73	73
60	Input Power HP (mech)	1.73	2.16
	Input Power HP (thermal)	0.93	0.93
	Output Torque lb-in (mech)	3977	3273
	Efficiency	70	70

STAINLESS STEEL SERVO 15-DIGIT CODE

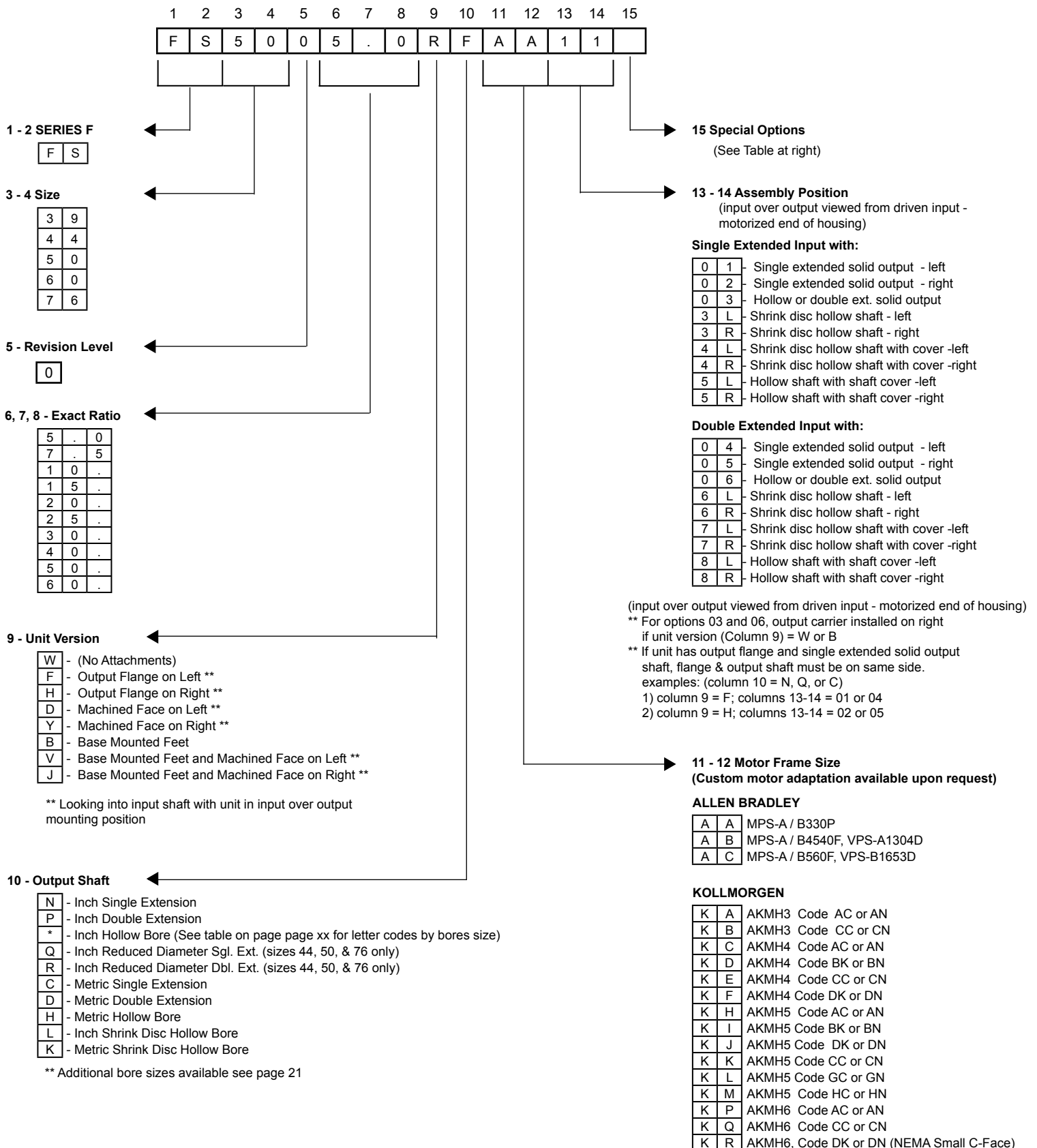

Engineering Data

Column 10 Entry - Inch Hollow Bore Sizes

Bore size	F039	F044	F050	F060	F076
0.625	E				
0.875	F	E			
1.000	A	F	E	E	
1.125		G	F	F	
1.188		--	G	G	
1.250		A	J	J	
1.438			A	A	E
1.750					F
1.938					G
2.188					A

Column 15 Entry - Special Feature Options

Column 15 Entry	Low Backlash	External Viton Seals	Foundation Hole Plugs
-			
A	•		
C		•	
F	•	•	
H			•
J	•		•
L		•	•
P	•	•	•

Moment of Inertia	RATIO	Units	SIZE				
			FS39	FS44	FS50	FS60	FS76
	5:1		lb·in·s ² x 10 ⁻⁴	9.32	12.06	22.47	30.84
		kg·cm ²	1.05	1.36	2.54	3.48	13.98
7.5:1		lb·in·s ² x 10 ⁻⁴	8.28	10.24	19.28	24.56	95.12
		kg·cm ²	0.93	1.16	2.18	2.77	10.74
10:1		lb·in·s ² x 10 ⁻⁴	7.92	9.61	18.17	22.36	85.07
		kg·cm ²	0.89	1.08	2.05	2.52	9.60
15:1		lb·in·s ² x 10 ⁻⁴	7.66	9.15	17.38	20.78	77.89
		kg·cm ²	0.86	1.03	1.96	2.35	8.79
20:1		lb·in·s ² x 10 ⁻⁴	7.57	8.99	17.10	20.23	75.38
		kg·cm ²	0.85	1.01	1.93	2.28	8.51
25:1		lb·in·s ² x 10 ⁻⁴	7.53	8.92	16.97	19.98	74.22
		kg·cm ²	0.85	1.01	1.92	2.26	8.38
30:1		lb·in·s ² x 10 ⁻⁴	7.53	8.88	16.90	19.84	73.58
		kg·cm ²	0.85	1.00	1.91	2.24	8.31
40:1		lb·in·s ² x 10 ⁻⁴	7.50	8.84	16.83	19.70	72.96
		kg·cm ²	0.85	1.00	1.90	2.22	8.23
50:1		lb·in·s ² x 10 ⁻⁴	7.48	8.82	16.80	19.64	72.67
		kg·cm ²	0.84	1.00	1.90	2.22	8.20
60:1		lb·in·s ² x 10 ⁻⁴	7.46	8.81	16.78	19.61	72.51
		kg·cm ²	0.84	0.99	1.89	2.21	8.18

*3D model configurator available at <http://conetools.com/Stainless/Content/Pages/DirectEntry.aspx>

Gearhead Size	Torsional Rigidity (All Ratios)		Backlash, arcmin (All Ratios)	
	in-lb / min	Nm / min	Standard	Low
FS39	51	5.8	24	8
FS44	67	7.6	20	7
FS50	92	10.4	15	6
FS60	157	17.7	13	5
FS76	368	41.6	10	4

Servo Motor Codes and Dimensions

Letter Codes Positions		KOLLMORGEN SERVO MOTOR	Gearhead Dimensions (mm)									
			Gearhead Size FS39		Gearhead Size FS44		Gearhead Size FS50		Gearhead Size FS60		Gearhead Size FS76	
11	12		Length A	Length B	Length A	Length B	Length A	Length B	Length A	Length B	Length A	Length B
K	A	AKMH3 Code AC, AN	149.5	132.5	155.5	138.5	158.5	141.5	--	--	--	--
K	B	AKMH3 Code CC, CN	149.5	132.5	155.5	138.5	158.5	141.5	--	--	--	--
K	C	AKMH4 Code AC, AN	171.2	132.5	177.2	138.5	180.2	141.5	187.8	149.1	213	174.3
K	D	AKMH4 Code BK, BN	171.2	132.5	177.2	138.5	180.2	141.5	187.8	149.1	213	174.3
K	E	AKMH4 Code CC, CN	171.2	132.5	177.2	138.5	180.2	141.5	187.8	149.1	213	174.3
K	F	AKMH4 Code DK, DN	171.2	132.5	177.2	138.5	180.2	141.5	187.8	149.1	213	174.3
K	H	AKMH5 Code AC, AN	196.7	168.7	202.7	174.7	205.7	177.7	213.3	185.3	238.5	210.5
K	I	AKMH5 Code BK, BN	196.7	168.7	202.7	174.7	205.7	177.7	213.3	185.3	238.5	210.5
K	J	AKMH5 Code DK, DN	196.7	168.7	202.7	174.7	205.7	177.7	213.3	185.3	238.5	210.5
K	K	AKMH5 Code CC, CN	196.7	168.7	202.7	174.7	205.7	177.7	213.3	185.3	238.5	210.5
K	L	AKMH5 Code GC, GN	196.7	168.7	202.7	174.7	205.7	177.7	213.3	185.3	238.5	210.5
K	M	AKMH5 Code HC, HN	196.7	168.7	202.7	174.7	205.7	177.7	213.3	185.3	238.5	210.5
K	P	AKMH6 Code AC, AN	--	--	--	--	--	--	230.3	185.3	255.5	210.5
K	Q	AKMH6 Code CC, CN	--	--	--	--	--	--	230.3	185.3	255.5	210.5
K	R	AKMH6 Code DK, DN	--	--	--	--	--	--	240.3	185.3	265.5	210.5

Letter Codes Positions		KOLLMORGEN SERVO MOTOR	Servo Motor Adapter Plate and Servo Motor Adapter Part Numbers									
			Gearhead Size FS39		Gearhead Size FS44		Gearhead Size FS50		Gearhead Size FS60		Gearhead Size FS76	
11	12		Plate	Motor Adapter	Plate	Motor Adapter	Plate	Motor Adapter	Plate	Motor Adapter	Plate	Motor Adapter
K	A	AKMH3 Code AC, AN	FS-PAK	50FS-M20P	FS-PAK	50FS-M20P	FS-PAK	50FS-M20P	--	--	--	--
K	B	AKMH3 Code CC, CN	FS-PAL	50FS-M20P	FS-PAL	50FS-M20P	FS-PAL	50FS-M20P	--	--	--	--
K	C	AKMH4 Code AC, AN	FS-PAM	50FS-M20P	FS-PAM	50FS-M20P	FS-PAM	50FS-M20P	FS-PAM	50FS-M20P	FS-PAM	50FS-M20P
K	D	AKMH4 Code BK, BN	FS-PAE	50FS-M20P	FS-PAE	50FS-M20P	FS-PAE	50FS-M20P	FS-PAE	50FS-M20P	FS-PAE	50FS-M20P
K	E	AKMH4 Code CC, CN	FS-PAC	50FS-M20P	FS-PAC	50FS-M20P	FS-PAC	50FS-M20P	FS-PAC	50FS-M20P	FS-PAC	50FS-M20P
K	F	AKMH4 Code DK, DN	FS-PAD	50FS-M20P	FS-PAD	50FS-M20P	FS-PAD	50FS-M20P	FS-PAD	50FS-M20P	FS-PAD	50FS-M20P
K	H	AKMH5 Code AC, AN	FS-AF	50FS-M20	FS-AF	50FS-M20	FS-AF	50FS-M20	FS-AF	50FS-M20	FS-AF	50FS-M20
K	I	AKMH5 Code BK, BN	FS-AR	50FS-M20	FS-AR	50FS-M20	FS-AR	50FS-M20	FS-AR	50FS-M20	FS-AR	50FS-M20
K	J	AKMH5 Code DK, DN	FS-AS	50FS-M20	FS-AS	50FS-M20	FS-AS	50FS-M20	FS-AS	50FS-M20	FS-AS	50FS-M20
K	K	AKMH5 Code CC, CN	FS-AG	50FS-M20	FS-AG	50FS-M20	FS-AG	50FS-M20	FS-AG	50FS-M20	FS-AG	50FS-M20
K	L	AKMH5 Code GC, GN	FS-AN	50FS-M20	FS-AN	50FS-M20	FS-AN	50FS-M20	FS-AN	50FS-M20	FS-AN	50FS-M20
K	M	AKMH5 Code HC, HN	FS-AP	50FS-M20	FS-AP	50FS-M20	FS-AP	50FS-M20	FS-AP	50FS-M20	FS-AP	50FS-M20
K	P	AKMH6 Code AC, AN	--	--	--	--	--	--	FS-AH	50FS-M20	FS-AH	50FS-M20
K	Q	AKMH6 Code CC, CN	--	--	--	--	--	--	FS-AJ	50FS-M20-1	FS-AJ	50FS-M20-1
K	R	AKMH6 Code DK, DN	--	--	--	--	--	--	FS-AQ	50FS-M20	FS-AQ	50FS-M20

Letter Codes Positions		ALLEN BRADLEY SERVO MOTOR	Gearhead Dimensions (mm)									
			Gearhead Size FS39		Gearhead Size FS44		Gearhead Size FS50		Gearhead Size FS60		Gearhead Size FS76	
11	12		Length A	Length B	Length A	Length B	Length A	Length B	Length A	Length B	Length A	Length B
A	A	MPS-A,B /330P	171.2	132.5	177.2	138.5	180.2	141.5	--	--	--	--
A	B	MPS-A/B4540F, VPS-A1304D	--	--	--	--	--	--	213.3	185.3	238.5	210.5
A	C	MPS-A/B560F, VPS-B1653D	--	--	--	--	--	--	230.3	185.3	255.5	210.5

Letter Codes Positions		ALLEN BRADLEY SERVO MOTOR	Servo Motor Adapter Plate and Servo Motor Adapter Part Numbers									
			Gearhead Size FS39		Gearhead Size FS44		Gearhead Size FS50		Gearhead Size FS60		Gearhead Size FS76	
11	12		Plate	Motor Adapter	Plate	Motor Adapter	Plate	Motor Adapter	Plate	Motor Adapter	Plate	Motor Adapter
A	A	MPS-A,B /330P	FS-PAC	50FS-M20P	FS-PAC	50FS-M20P	FS-PAC	50FS-M20P	--	--	--	--
A	B	MPS-A/B4540F, VPS-A1304D	--	--	--	--	--	--	FS-AG	50FS-M20	FS-AG	50FS-M20
A	C	MPS-A/B560F, VPS-B1653D	--	--	--	--	--	--	FS-AJ	50FS-M20-1	FS-AJ	50FS-M20-1

Servo Motor Codes and Dimensions

Letter Codes		KOLLMORGEN SERVO MOTOR	Motor Adapter & Plate Pin		Servo Motor Dimensions					
11	12		Plate	Motor Adapter	Outer Dia.	Pilot Dia.	Bolt Circle Dia.	Hole Size	Shaft Dia.	Shaft Length
K	A	AKMH3 Code AC, AN	FS-PAK	50FS-M20P	89	60	75	5.8	14	30
K	B	AKMH3 Code CC,CN	FS-PAL	50FS-M20P	89	60	75	M5	14	30
K	C	AKMH4 Code AC, AN	FS-PAM	50FS-M20P	114.5	80	100	7.0	19	40
K	D	AKMH4 Code BK, BN	FS-PAE	50FS-M20P	114.5	73.025	98.43	6.91	15.875	52.4
K	E	AKMH4 Code CC, CN	FS-PAC	50FS-M20P	114.5	80	100	M6	19	40
K	F	AKMH4 Code DK, DN	FS-PAD	50FS-M20P	114.5	73.025	98.43	1/4 - 20	15.875	52.4
K	H	AKMH5 Code AC, AN	FS-AF	50FS-M20	148	110	130	9	24	50
K	I	AKMH5 Code BK, BN	FS-AR	50FS-M20	148	55.563	125.73	8.33	19.05	57.15
K	J	AKMH5 Code DK, DN	FS-AS	50FS-M20	148	55.563	125.73	3/8 - 16	19.05	57.15
K	K	AKMH5 Code CC, CN	FS-AG	50FS-M20	148	110	130	M8	24	50
K	L	AKMH5 Code GC, GN	FS-AN	50FS-M20	148	95	115	9	24	50
K	M	AKMH5 Code HC, HN	FS-AP	50FS-M20	148	95	115	M8	24	50
K	P	AKMH6 Code AC, AN	FS-AH	50FS-M20	186.4	130	165	11	32	58
K	Q	AKMH6 Code CC, CN	FS-AJ	50FS-M20-1	186.4	130	165	M10	32	58
K	R	AKMH6 Code DK, DN	FS-AQ	50FS-M20	186.4	114.5	149.23	3/8 - 16	28.58	69.9

Letter Codes		ALLEN BRADLEY SERVO MOTOR	Motor Adapter & Plate P/N		Servo Motor Dimensions					
11	12		Plate	Motor Adapter	Outer Dia.	Pilot Dia.	Bolt Circle Dia.	Hole Size	Shaft Dia.	Shaft Length
A	A	MPS-A,B /330P	FS-PAC	50FS-M20P	112	80	100	M6	16	40
A	B	MPS-A/B4540F, VPS-A1304D	FS-AG	50FS-M20	143.2	110	130	M8	24	50
A	C	MPS-A/B560F, VPS-B1653D	FS-AJ	50FS-M20-1	181	130	165	M10	28	60

Selection Process

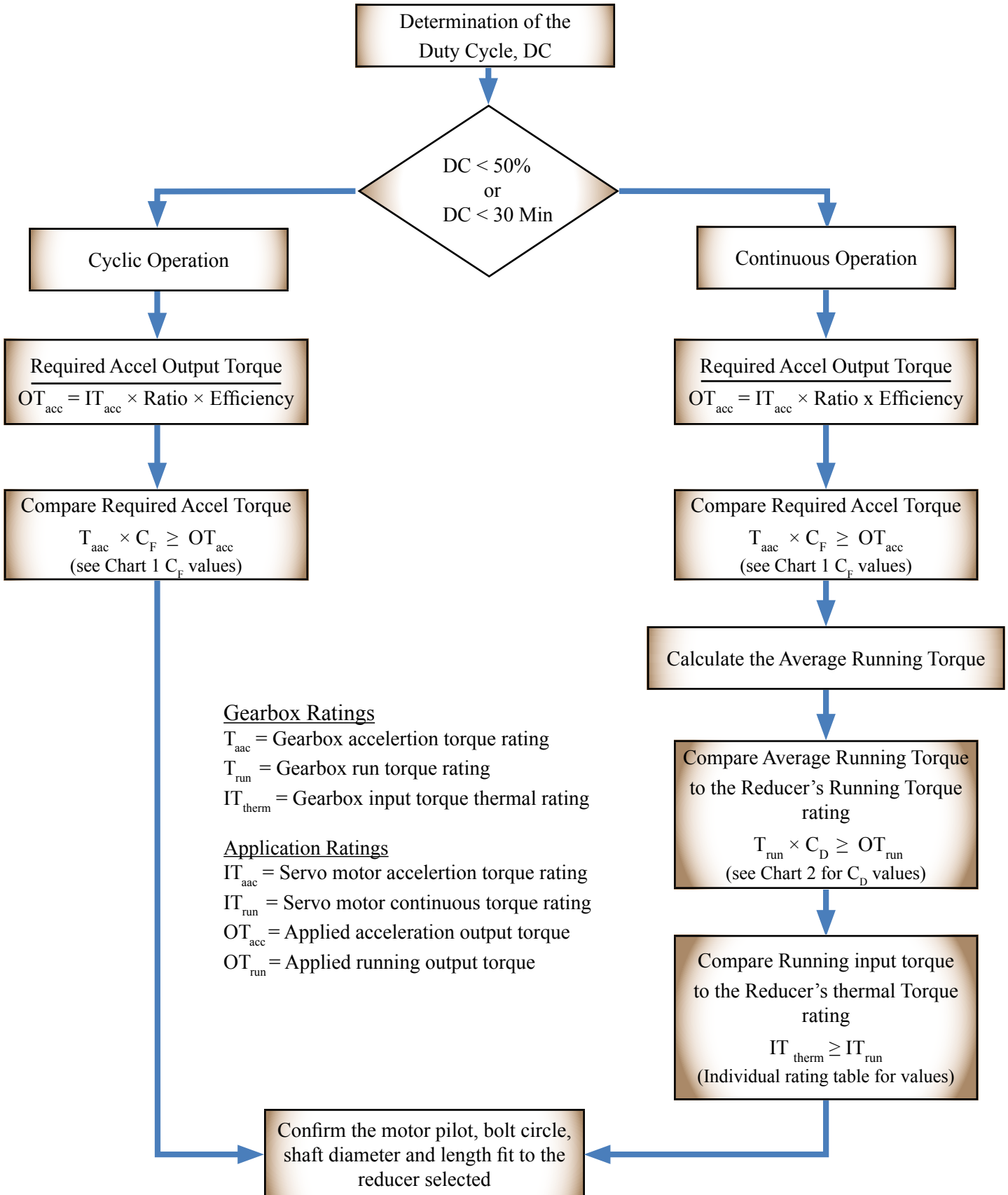

Reducer Selection

Chart 1 : Cycle Factor, C_F

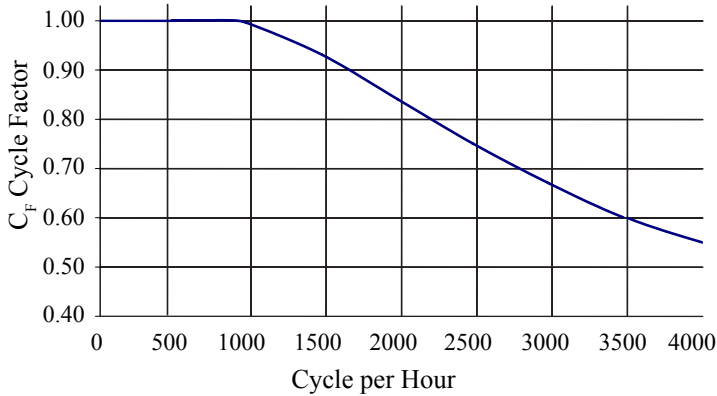
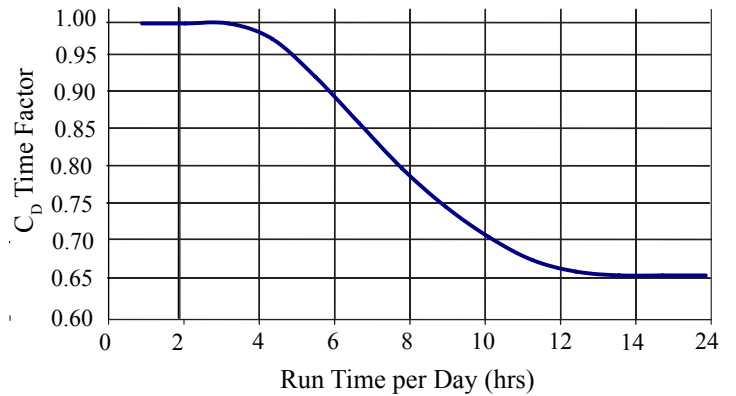

Chart 2 : Time Factor, C_D



Equation 1

$$\text{Duty Cycle} = \frac{\text{On Time}}{\text{On Time} + \text{Off Time}} \times 100$$

Where n = speed,
 t = time and
 T = torque for each cycle segment

Equation 2

$$T_2 = \sqrt[3]{\frac{(n_1 \cdot t_1 \cdot T_1^3 + \dots + n_n \cdot t_n \cdot T_n^3)}{n_1 \cdot t_1 + \dots + n_n \cdot t_n}}$$

Example

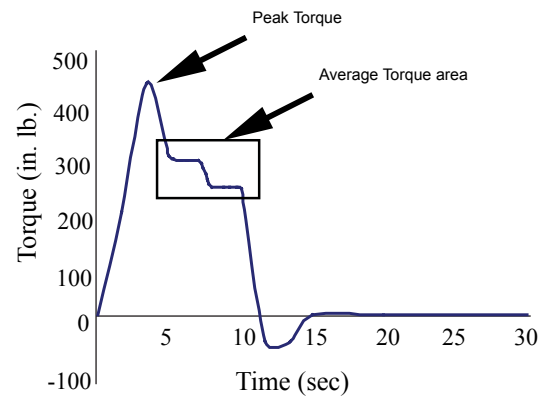
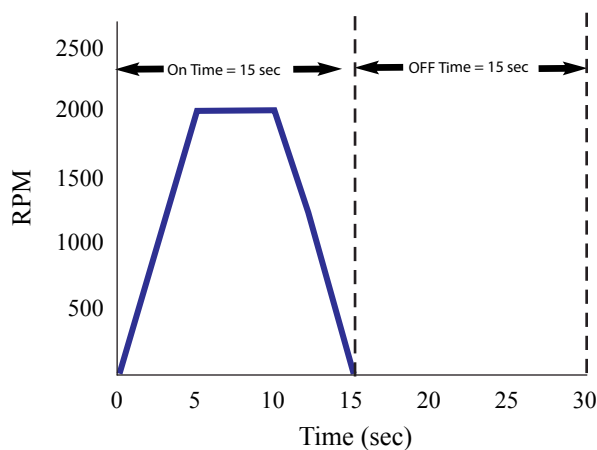

$$\text{Duty cycle \%} = (15)/(15 + 15) \times 100 = 50\%$$

$$T_{1 \text{ acc motor}} = 450 \text{ lb.in.}$$

$$T_2 = (300 \times 2.5 + 250 \times 2.5) / (2.5 + 2.5)$$

Dimensions and Options for Size FS39

Solid Output Shaft Version

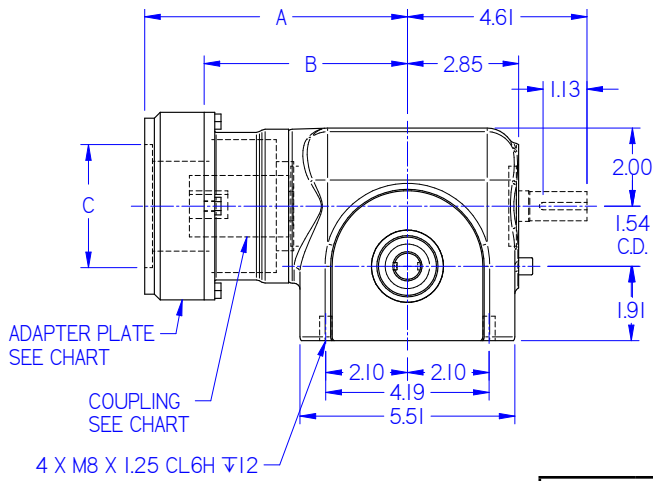

APPROX. SHIPPING WT: 29.2 lbs.

INCH SOLID		METRIC SOLID	
SHAFT DIA.	KEY WAY	SHAFT DIA.	KEY WAY
0.750	3/16 x 3/32	18	6.0 x 3.0

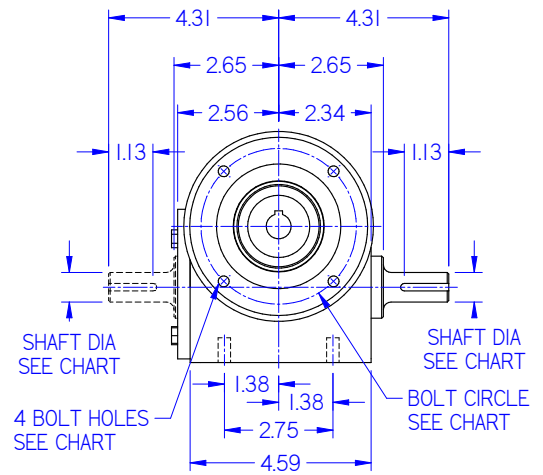

Hollow Output Shaft Version

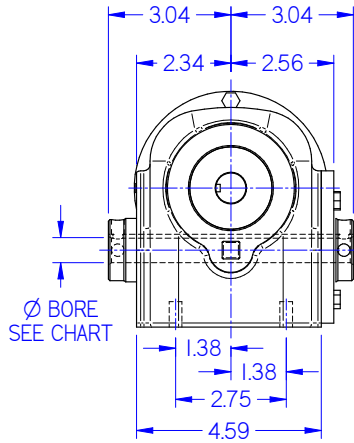

APPROX. SHIPPING WT: 26.8 lbs.

INCH HOLLOW		METRIC HOLLOW	
BORE DIA.	KEYWAY	BORE DIA.	KEYWAY
0.625	3/16 x 3/32	19	6.0 x 3.0
0.875	3/16 x 3/32		
1.000	1/4 x 1/8		

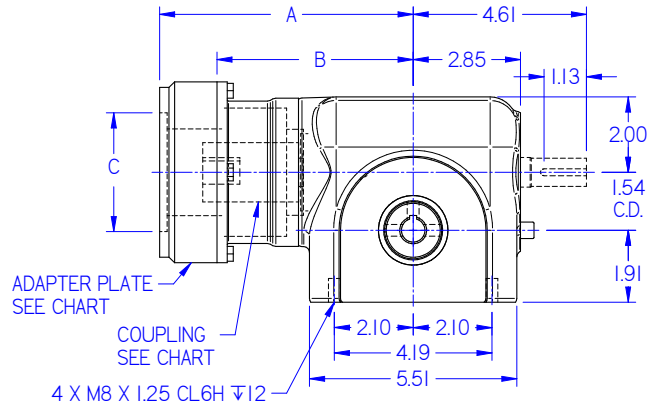

Shrink Disc Shaft Version

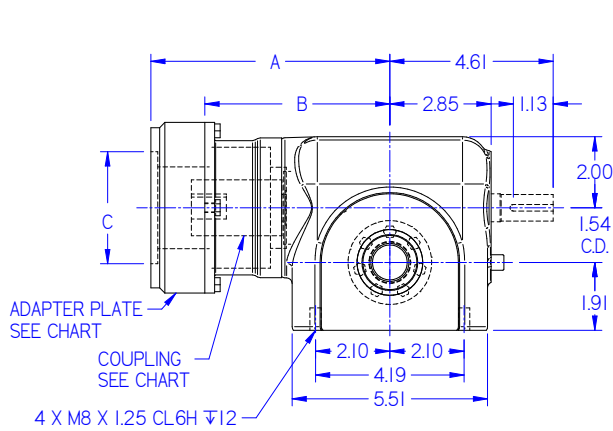

APPROX. SHIPPING WT: 29.8 lbs.

INCH BORE		METRIC BORE	
1.000/1.003		25.000/25.008	

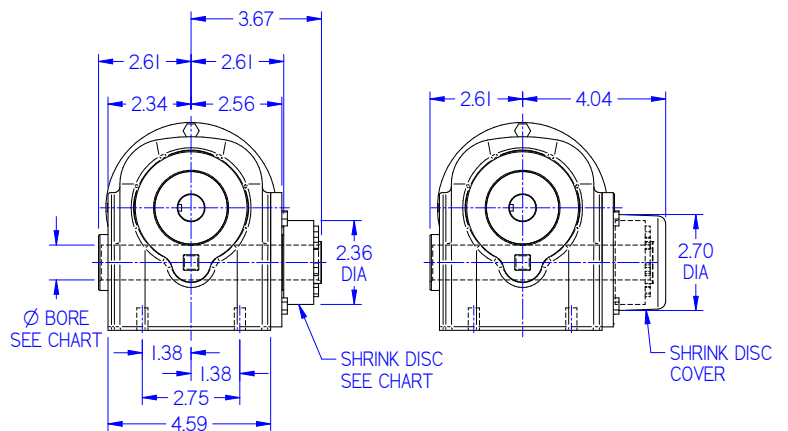

Dimensions and Options for Size FS39

Output Flange Version

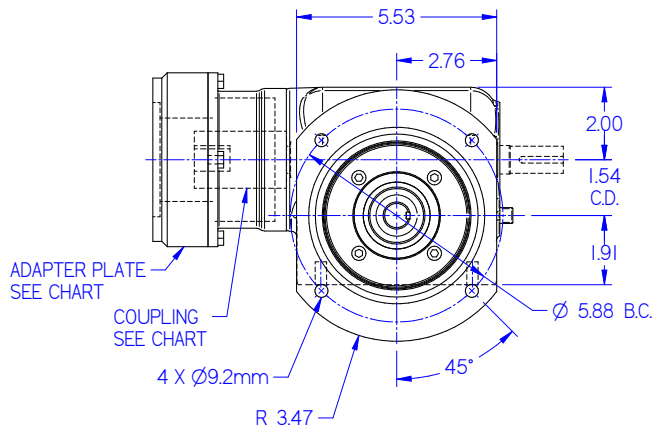

APPROX. SHIPPING WT: 29.0 lbs.

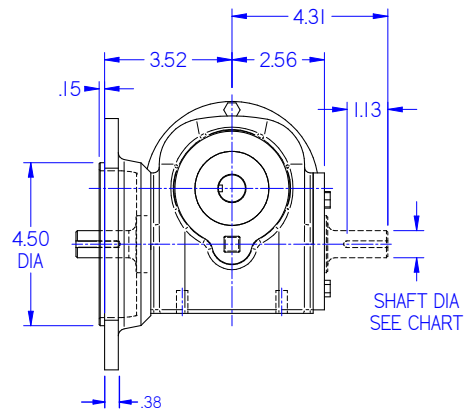

AVAILABLE WITH EITHER A SOLID OR HOLLOW OUTPUT

Side Mount Version

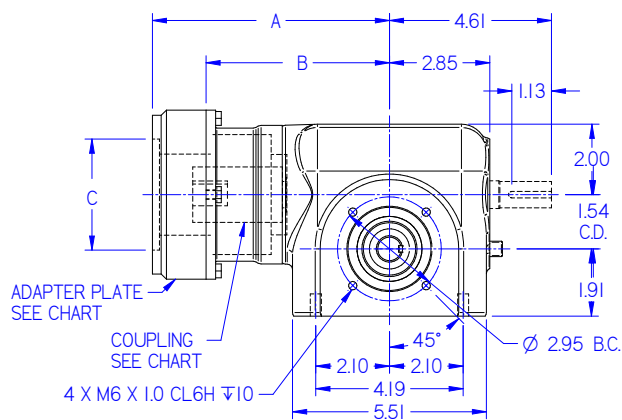

APPROX. SHIPPING WT: 29.2 lbs.

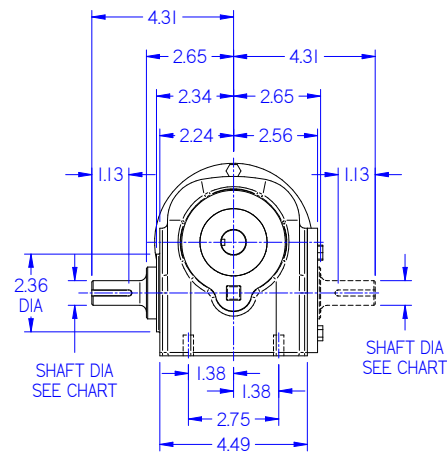

AVAILABLE WITH EITHER A SOLID OR HOLLOW OUTPUT

Foot Mount Version

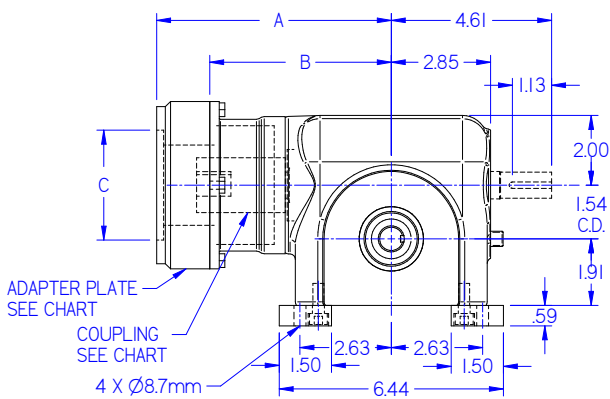

APPROX. SHIPPING WT: 31.6 lbs.

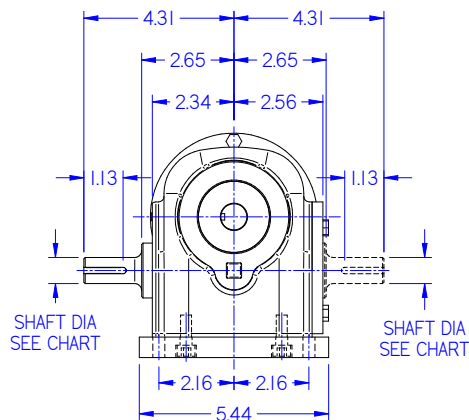

AVAILABLE WITH EITHER A SOLID OR HOLLOW OUTPUT

Dimensions and Options for Size FS44

Solid Output Shaft Version

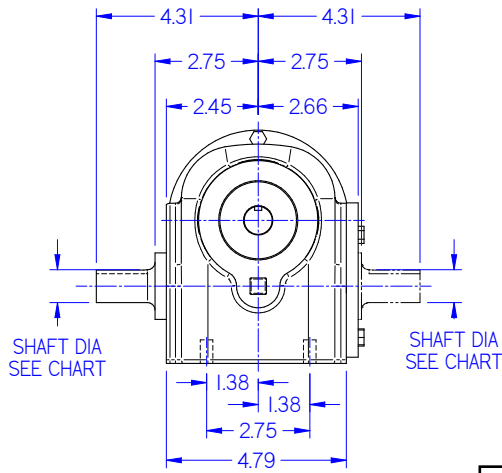

APPROX. SHIPPING WT: 33.2 lbs.

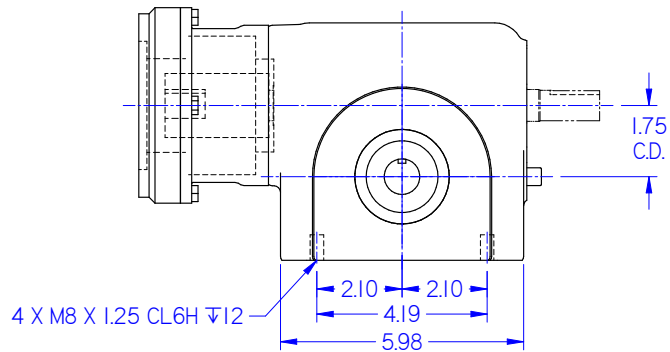

INCH SOLID		METRIC SOLID	
SHAFT DIA.	KEY WAY	SHAFT DIA.	KEY WAY
0.875	3/16 X 3/32	20	6.0 X 3.0
1.000	1/4 X 1/8		

Hollow Output Shaft Version

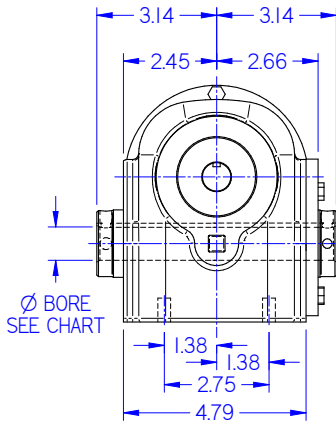

APPROX. SHIPPING WT: 31.3 lbs.

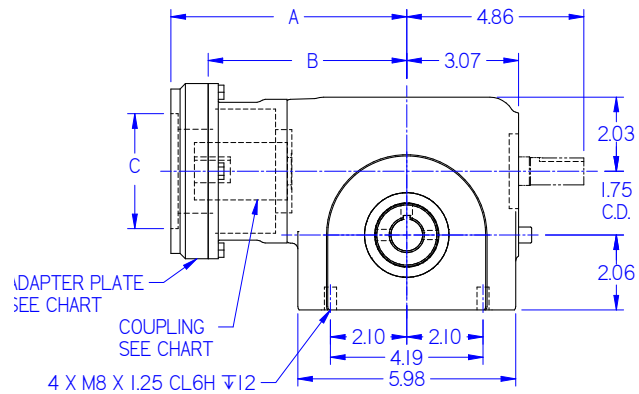

INCH HOLLOW		METRIC HOLLOW	
BORE DIA.	KEYWAY	BORE DIA.	KEYWAY
0.875	3/16 X 3/32	20	6.0 X 3.0
1.000	1/4 X 1/8		
1.125	1/4 X 1/8		
1.250	1/4 X 1/8		

Shrink Disc Shaft Version

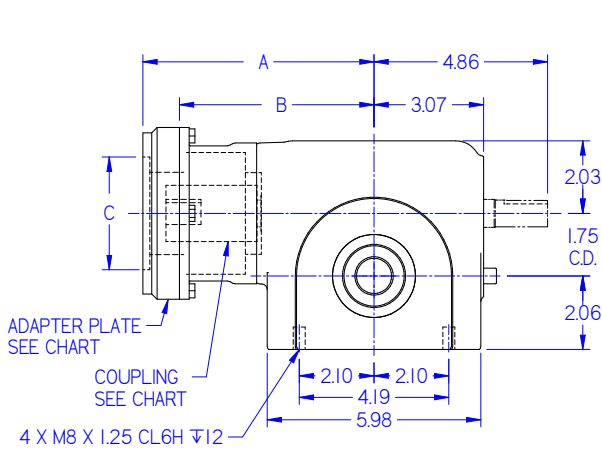

APPROX. SHIPPING WT: 34.3 lbs.

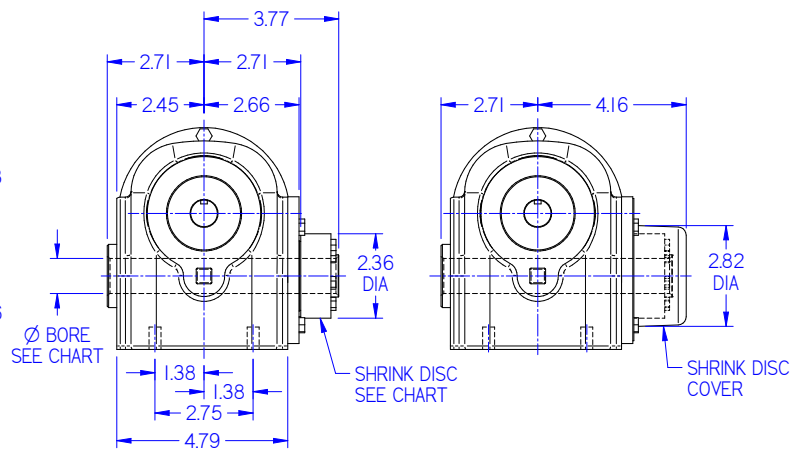

INCH BORE		METRIC BORE	
1.000/1.003		25.000/25.008	

Dimensions and Options for Size FS44

Output Flange Version

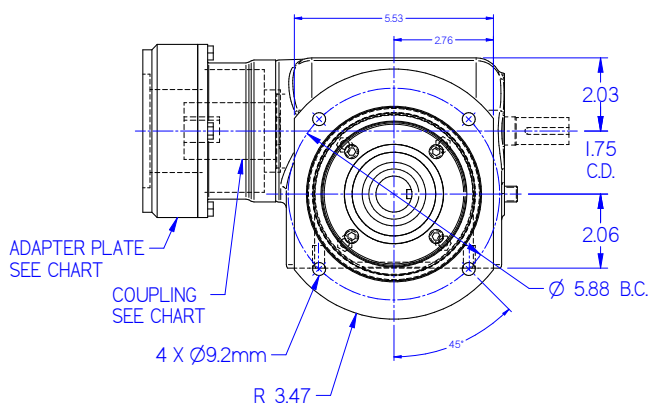

APPROX. SHIPPING WT: 32.7 lbs.

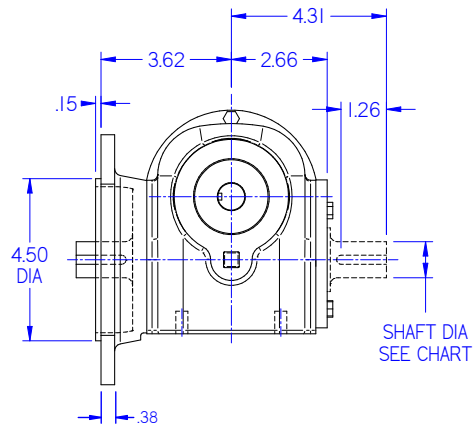

AVAILABLE WITH EITHER A SOLID OR HOLLOW OUTPUT

Side Mount Version

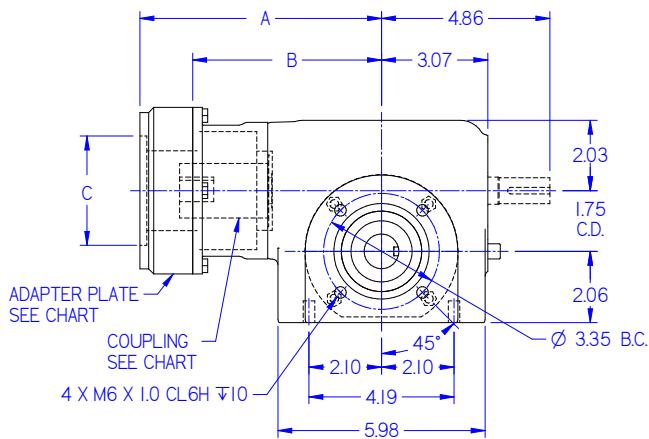

APPROX. SHIPPING WT: 33.2 lbs.

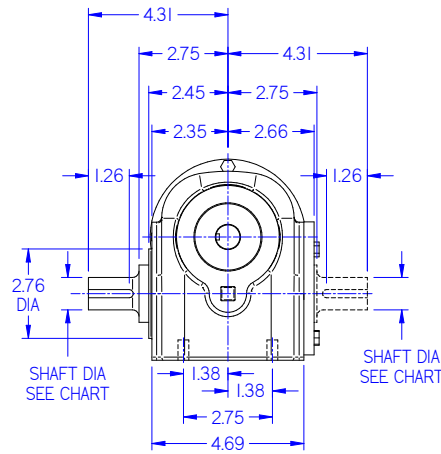

AVAILABLE WITH EITHER A SOLID OR HOLLOW OUTPUT

Foot Mount Version

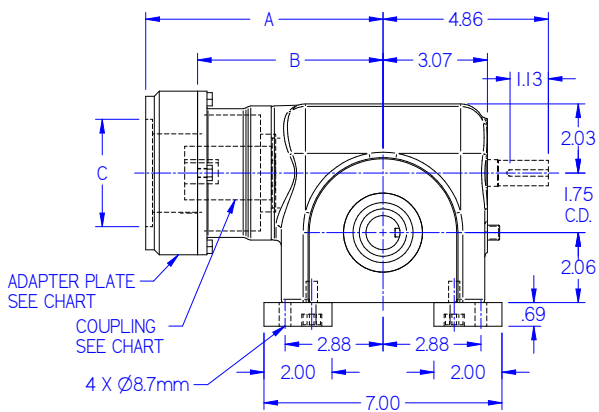

APPROX. SHIPPING WT: 37.4 lbs.

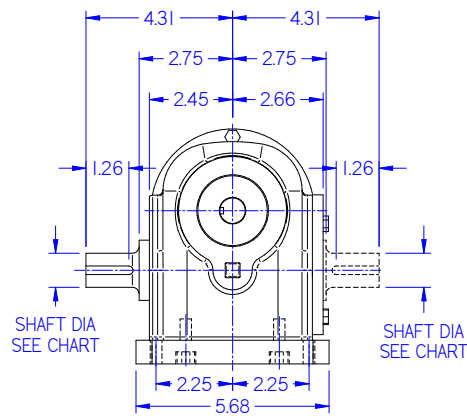

AVAILABLE WITH EITHER A SOLID OR HOLLOW OUTPUT

Dimensions and Options for Size FS50

Solid Output Shaft Version

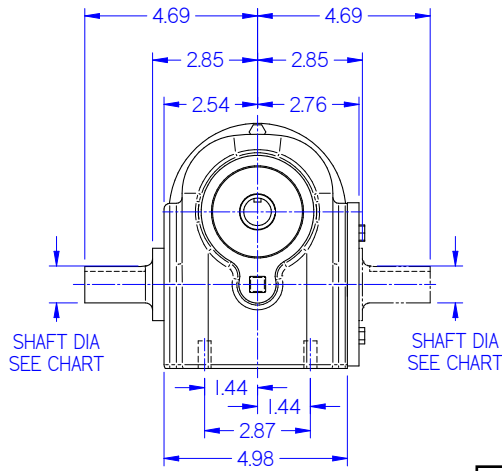

APPROX. SHIPPING WT: 35 lbs.

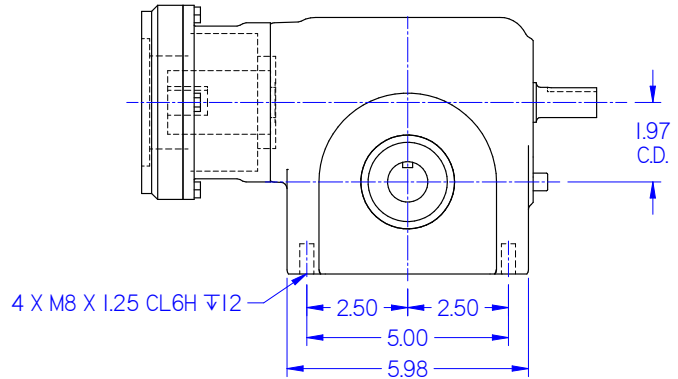

INCH SOLID		METRIC SOLID	
SHAFT DIA.	KEY WAY	SHAFT DIA.	KEY WAY
1.000	1/4 X 1/8	25	8.0 X 4.0
1.125	1/4 X 1/8		

Hollow Output Shaft Version

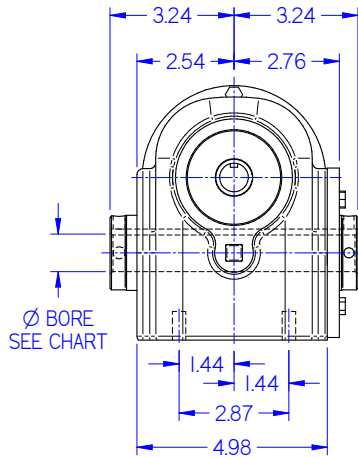

APPROX. SHIPPING WT: 32.1 lbs.

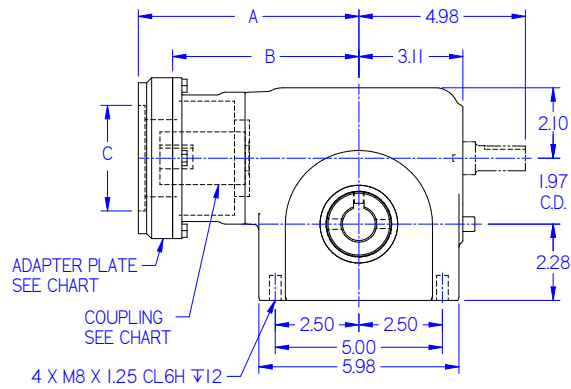

INCH HOLLOW		METRIC HOLLOW	
SHAFT DIA.	KEY WAY	SHAFT DIA.	KEY WAY
0.875	3/16 X 3/32	25	8.0 x 4.0
1.000	1/4 X 1/8		
1.125	1/4 X 1/8		
1.250	1/4 X 1/8		

Shrink Disc Shaft Version

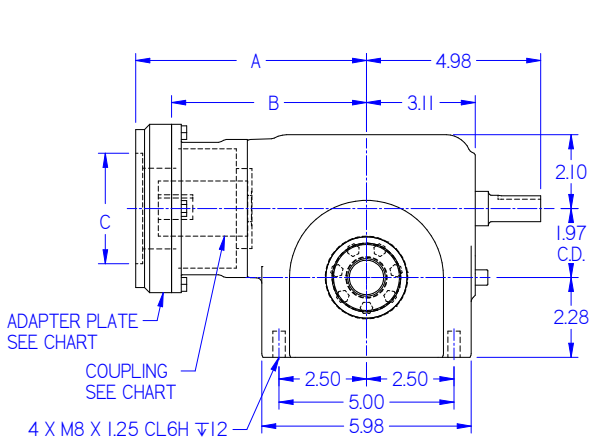

APPROX. SHIPPING WT: 36.2 lbs.

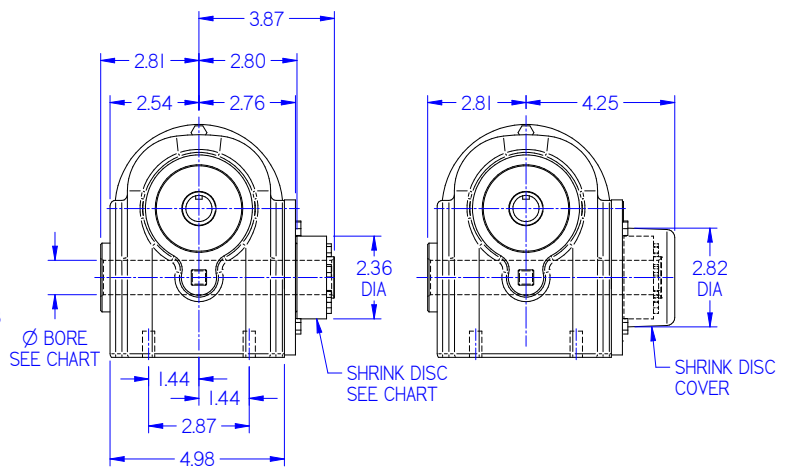

INCH BORE		METRIC BORE	
1.000/1.003		25.000/25.008	

Dimensions and Options for Size FS50

Output Flange Version

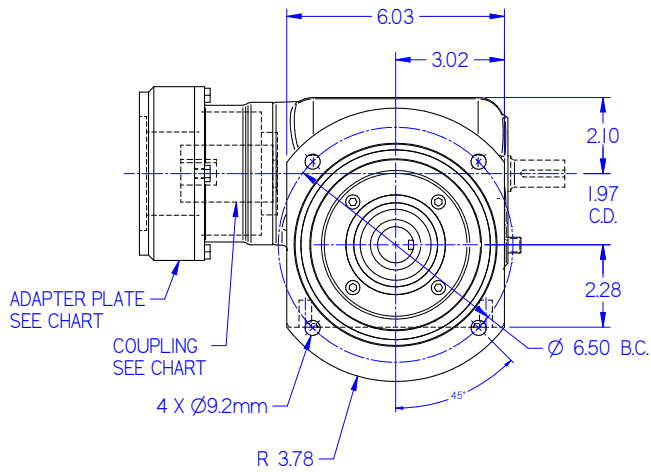

APPROX. SHIPPING WT: 36.2 lbs.

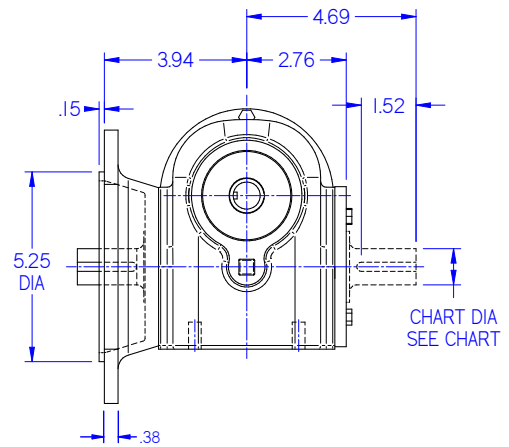

AVAILABLE WITH EITHER A SOLID OR HOLLOW OUTPUT

Side Mount Version

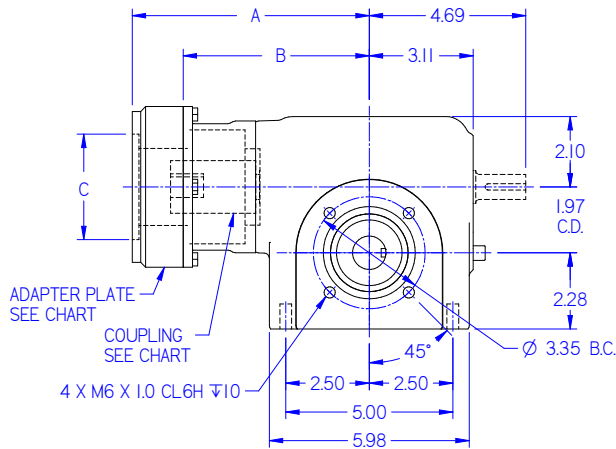

APPROX. SHIPPING WT: 35 lbs.

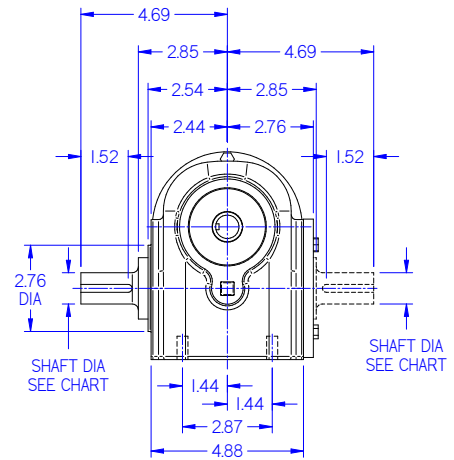

AVAILABLE WITH EITHER A SOLID OR HOLLOW OUTPUT

Foot Mount Version

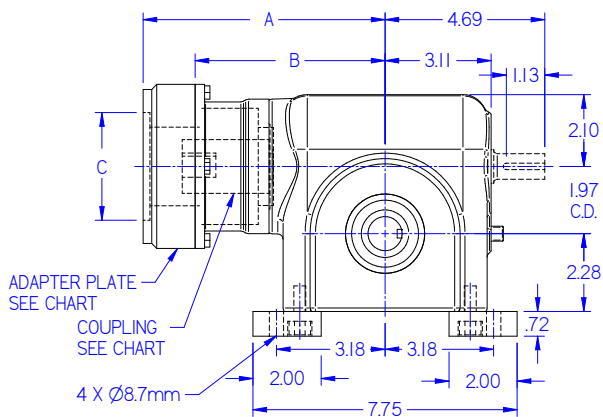

APPROX. SHIPPING WT: 39.6 lbs.

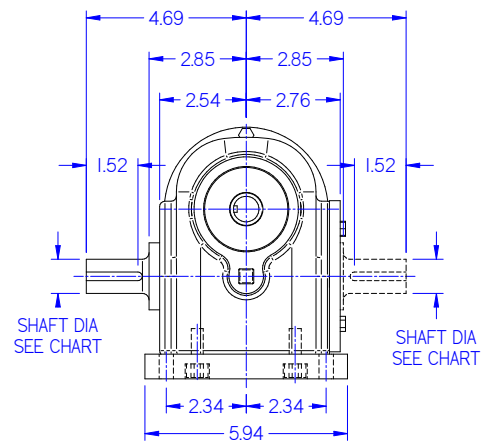

AVAILABLE WITH EITHER A SOLID OR HOLLOW OUTPUT

Dimensions and Options for Size FS60

Solid Output Shaft Version

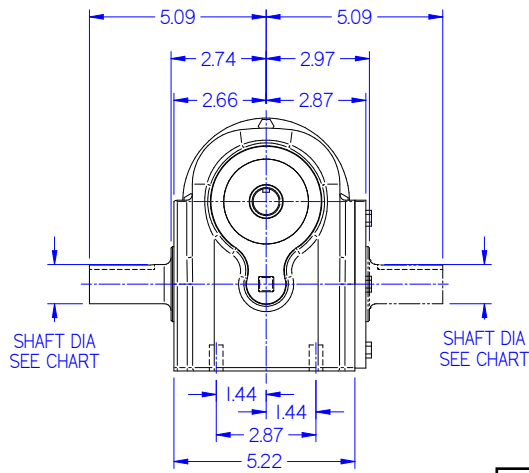

APPROX. SHIPPING WT: 43.3 lbs.

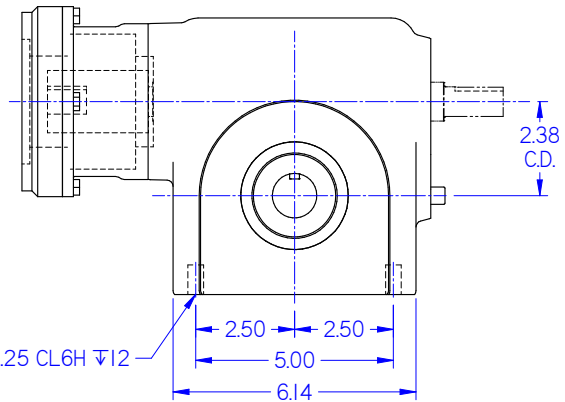

INCH SOLID		METRIC SOLID	
SHAFT DIA.	KEY WAY	SHAFT DIA.	KEY WAY
1.125	1/4 X 1/8	28	8.0 X 4.0

Hollow Output Shaft Version

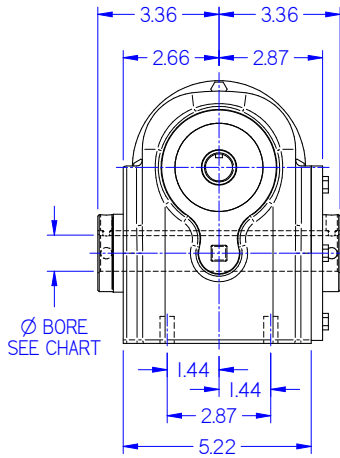

APPROX. SHIPPING WT: 39.7 lbs.

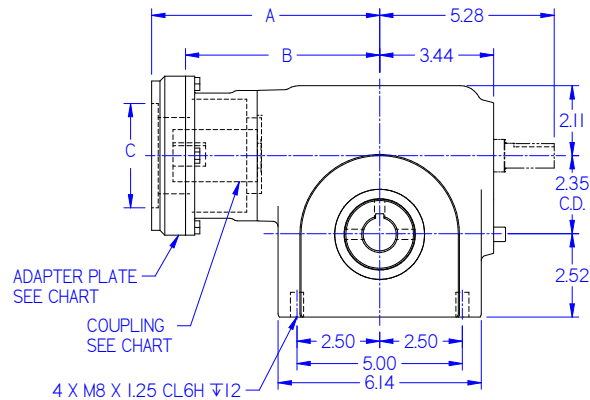

INCH HOLLOW		METRIC HOLLOW	
SHAFT DIA.	KEY WAY	SHAFT DIA.	KEY WAY
1.000	1/4 X 1/8	28	8.0 x 4.0
1.125	1/4 X 1/8		
1.188	1/4 X 1/8		
1.250	1/4 X 1/8		
1.438	1/4 X 1/8		

Shrink Disc Shaft Version

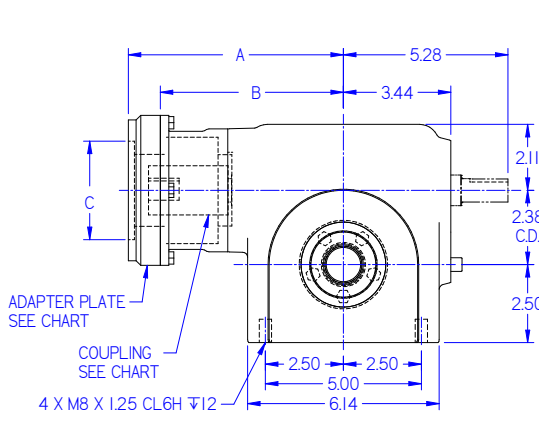

APPROX. SHIPPING WT: 43.7 lbs.

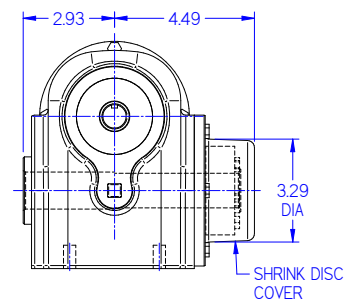
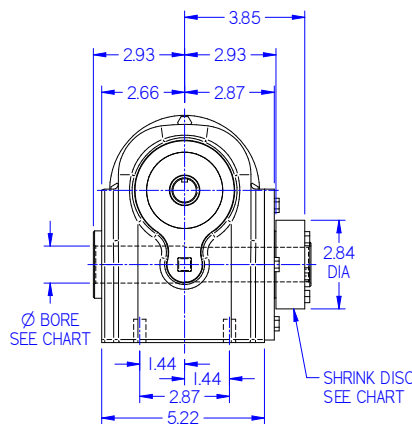

INCH BORE		METRIC BORE	
1.250/1.2506		30.000/30.008	

Dimensions and Options for Size FS60

Output Flange Version

7.29
 3.64
 2.11
 2.38 C.D.
 2.50
 ADAPTER PLATE SEE CHART
 COUPLING SEE CHART
 4 X Ø9.2mm
 R 4.54
 APPROX. SHIPPING WT: 44.8 lbs.

5.09
 4.45
 2.87
 1.75
 6.50 DIA
 .15
 .38
 SHAFT DIA SEE CHART
 AVAILABLE WITH EITHER A SOLID OR HOLLOW OUTPUT

Side Mount Version

A
 5.28
 B
 3.44
 1.13
 2.11
 2.38 C.D.
 2.50
 ADAPTER PLATE SEE CHART
 COUPLING SEE CHART
 4 X M6 X 1.0 CL6H ∇ 10
 2.50
 2.50
 5.00
 6.14
 APPROX. SHIPPING WT: 43.3 lbs.

5.09
 2.74
 5.09
 2.66
 2.97
 2.44
 2.87
 1.75
 1.75
 3.15 DIA
 SHAFT DIA SEE CHART
 1.44
 1.44
 2.87
 5.12
 SHAFT DIA SEE CHART
 AVAILABLE WITH EITHER A SOLID OR HOLLOW OUTPUT

Foot Mount Version

A
 5.28
 B
 3.44
 1.13
 2.11
 2.38 C.D.
 2.50
 .75
 ADAPTER PLATE SEE CHART
 COUPLING SEE CHART
 4 X Ø8.7mm
 2.50
 3.53
 3.53
 2.50
 8.50
 APPROX. SHIPPING WT: 49.1 lbs.

5.09
 5.09
 2.74
 2.97
 2.66
 2.87
 1.75
 1.75
 SHAFT DIA SEE CHART
 2.44
 2.44
 6.18
 SHAFT DIA SEE CHART
 AVAILABLE WITH EITHER A SOLID OR HOLLOW OUTPUT

Dimensions and Options for Size FS76

Solid Output Shaft Version

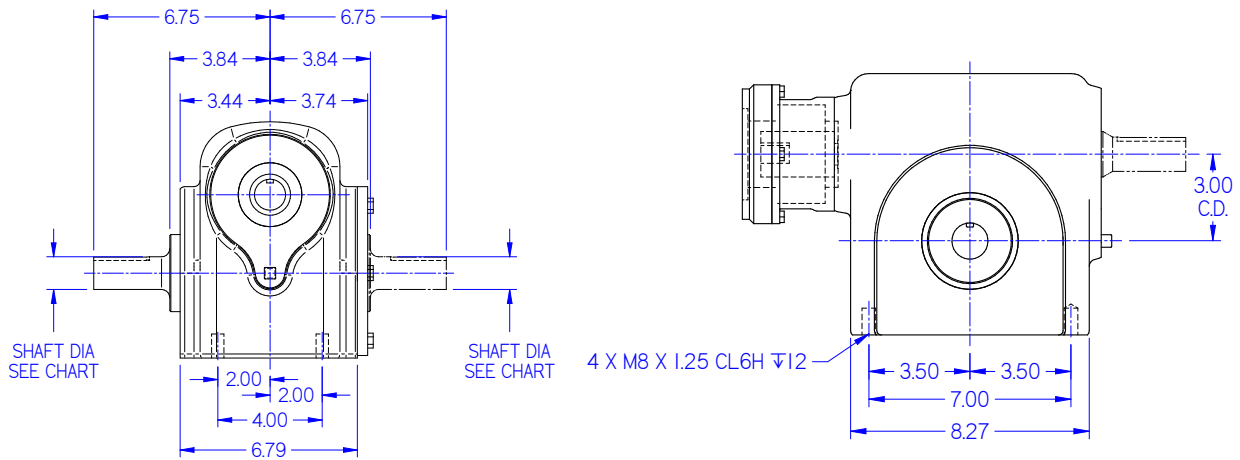

APPROX. SHIPPING WT: 90.8 lbs.

INCH SOLID		METRIC SOLID	
SHAFT DIA.	KEY WAY	SHAFT DIA.	KEY WAY
1.250	1/4 X 1/8	35	10 x 4.4
1.500	3/8 X 3/16		

Hollow Output Shaft Version

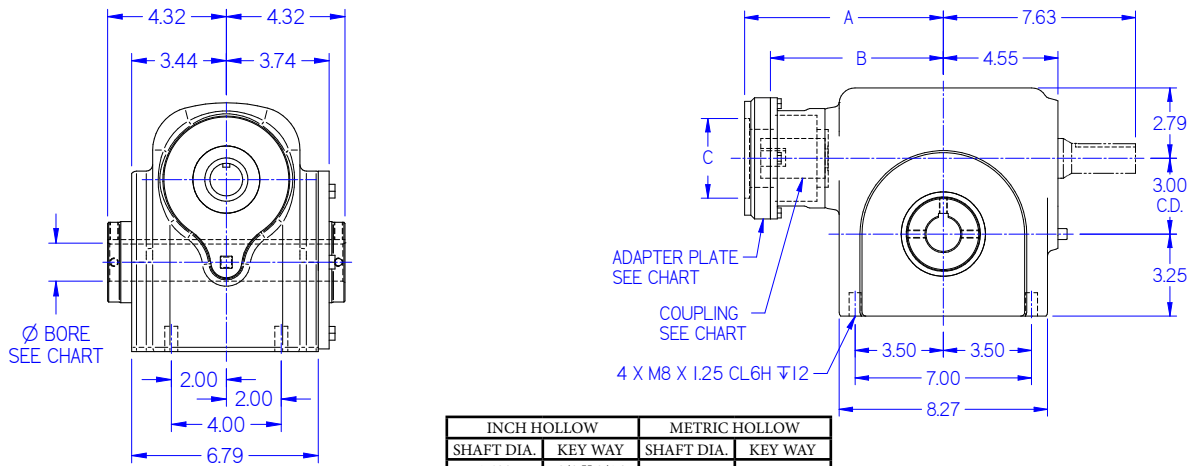

APPROX. SHIPPING WT: 82.3 lbs.

INCH HOLLOW		METRIC HOLLOW	
SHAFT DIA.	KEY WAY	SHAFT DIA.	KEY WAY
1.438	3/8 X 3/16	35	10 x 4.4
1.750	3/8 X 3/16		
1.938	1/2 X 1/4		
2.188	1/2 X 1/4		

Shrink Disc Shaft Version

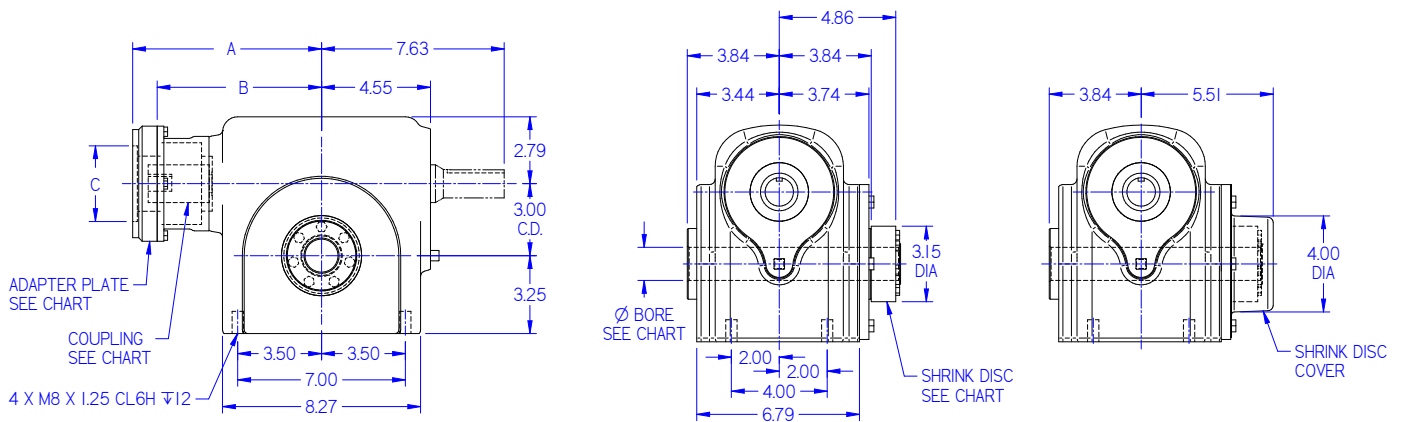

APPROX. SHIPPING WT: 88.3 lbs.

INCH BORE		METRIC BORE	
1.4375/1.438		35.002/35.018	

Dimensions and Options for Size FS76

Output Flange Version

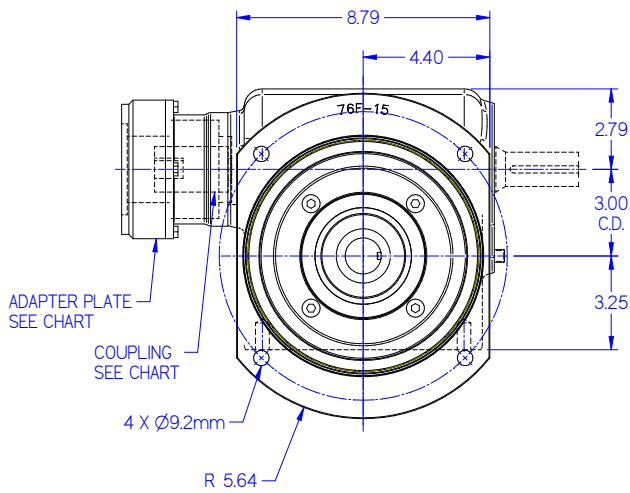

APPROX. SHIPPING WT: 92.7 lbs.

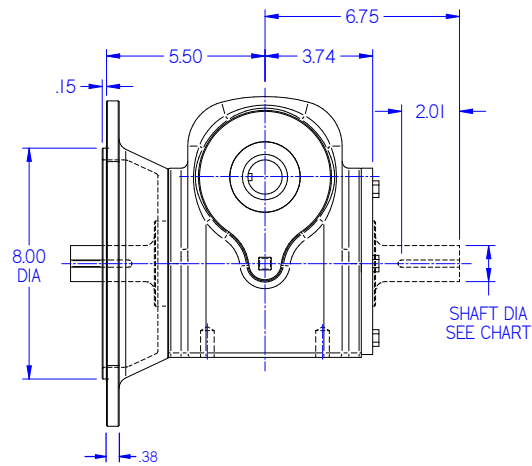

AVAILABLE WITH EITHER A SOLID OR HOLLOW OUTPUT

Side Mount Version

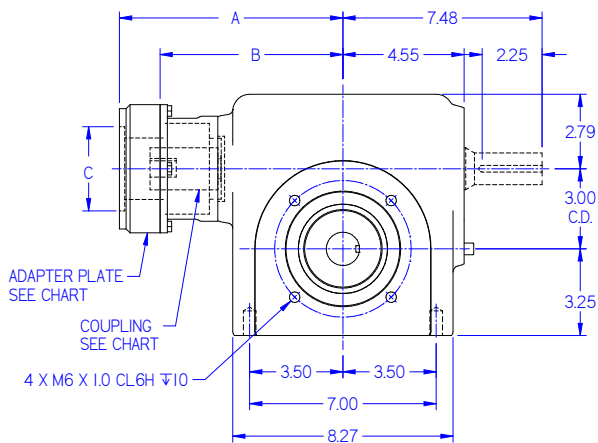

APPROX. SHIPPING WT: 90.8 lbs.

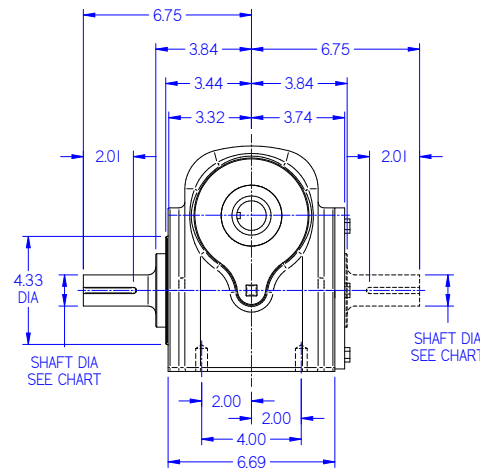

AVAILABLE WITH EITHER A SOLID OR HOLLOW OUTPUT

Foot Mount Version

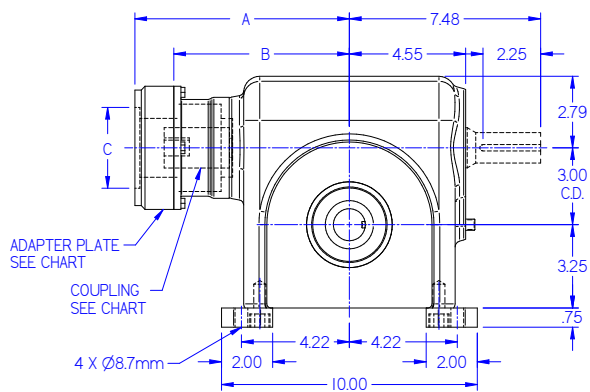

APPROX. SHIPPING WT: 96.8 lbs.

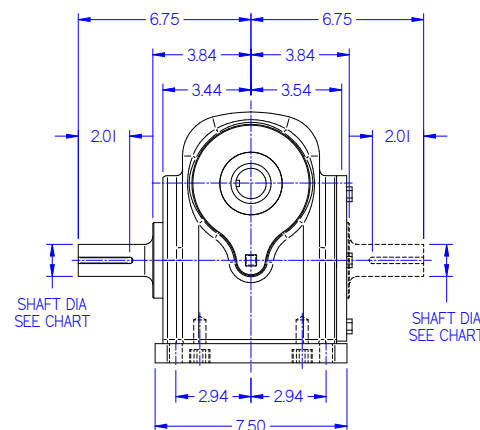

AVAILABLE WITH EITHER A SOLID OR HOLLOW OUTPUT

Ratings for Size FS39

RATIO	CAPACITY	Input Speed , RPM							
		500		1000		2000		3000	
		Lb-In	Nm	Lb-In	Nm	Lb-In	Nm	Lb-In	Nm
5	Input Torque Taccel	139	15.7	126	14.3	109	12.3	93	10.5
	Input Torque Trun	128	14.4	108	12.3	81	9.1	66	7.5
	IT Thermal, Ttherm	127	14.4	108	12.2	78	8.9	45	5.1
	Output Torque Taccel	631	71.3	581	65.7	499	56.4	422	47.7
	Output Torque Trun	581	65.7	499	56.4	370	41.8	300	33.9
	Efficiency %	91		92		92		91	
7.5	Input Torque Taccel	114	12.9	104	11.7	91	10.3	79	8.9
	Input Torque Trun	106	12.0	91	10.3	68	7.7	56	6.3
	IT Thermal, Ttherm	106	12.0	91	10.2	67	7.6	40	4.6
	Output Torque Taccel	763	86.2	707	79.9	620	70.1	530	59.9
	Output Torque Trun	707	79.9	620	70.1	461	52.1	376	42.5
	Efficiency %	89		91		91		90	
10	Input Torque Taccel	94	10.7	85	9.6	77	8.7	67	7.6
	Input Torque Trun	88	10.0	77	8.7	58	6.5	48	5.4
	IT Thermal, Ttherm	88	10.0	77	8.7	58	6.5	37	4.2
	Output Torque Taccel	822	92.9	768	86.8	689	77.9	593	67.0
	Output Torque Trun	768	86.8	689	77.9	517	58.4	424	47.9
	Efficiency %	87		90		90		89	
15	Input Torque Taccel	76	8.5	69	7.7	62	7.1	55	6.2
	Input Torque Trun	72	8.1	62	7.0	47	5.3	39	4.4
	IT Thermal, Ttherm	72	8.1	62	7.0	47	5.3	32	3.6
	Output Torque Taccel	955	108	905	102	823	93.0	713	80.6
	Output Torque Trun	905	102	823	93.0	623	70.4	510	57.6
	Efficiency %	84		88		88		87	
20	Input Torque Taccel	57	6.4	53	6.0	47	5.4	42	4.8
	Input Torque Trun	55	6.2	48	5.4	36	4.1	30	3.4
	IT Thermal, Ttherm	55	6.2	48	5.4	36	4.1	26	3.0
	Output Torque Taccel	927	105	892	101	806	91.1	706	79.8
	Output Torque Trun	892	101	806	91.1	617	69.7	505	57.1
	Efficiency %	81		84		85		84	
25	Input Torque Taccel	45	5.1	43	4.9	38	4.3	34	3.8
	Input Torque Trun	44	5.0	39	4.4	29	3.3	24	2.8
	IT Thermal, Ttherm	44	5.0	39	4.4	29	3.3	24	2.8
	Output Torque Taccel	909	103	896	101	804	90.9	703	79.4
	Output Torque Trun	896	101	804	90.9	615	69.5	503	56.8
	Efficiency %	81		83		84		83	
30	Input Torque Taccel	39	4.4	35	3.9	32	3.6	29	3.2
	Input Torque Trun	37	4.2	32	3.6	25	2.8	20	2.3
	IT Thermal, Ttherm	37	4.2	32	3.6	25	2.8	20	2.2
	Output Torque Taccel	864	97.6	823	93.0	768	86.8	673	76.0
	Output Torque Trun	823	93.0	768	86.8	588	66.4	481	54.4
	Efficiency %	74		79		80		79	
40	Input Torque Taccel	28	3.2	26	2.9	24	2.7	22	2.4
	Input Torque Trun	28	3.1	24	2.8	18	2.1	15	1.7
	IT Thermal, Ttherm	28	3.1	24	2.8	18	2.1	15	1.7
	Output Torque Taccel	786	88.8	784	88.6	734	82.9	644	72.8
	Output Torque Trun	784	88.6	734	82.9	561	63.4	459	51.9
	Efficiency %	70		75		76		75	
50	Input Torque Taccel	22	2.5	21	2.4	19	2.2	17	2.0
	Input Torque Trun	22	2.5	20	2.2	15	1.7	12	1.4
	IT Thermal, Ttherm	22	2.5	20	2.2	15	1.7	12	1.4
	Output Torque Taccel	764	86.3	764	86.3	707	79.9	620	70.1
	Output Torque Trun	764	86.3	707	79.9	541	61.1	442	49.9
	Efficiency %	68		72		73		72	
60	Input Torque Taccel	19	2.1	17	2.0	16	1.8	14	1.6
	Input Torque Trun	19	2.1	16	1.8	12	1.4	10	1.2
	IT Thermal, Ttherm	19	2.1	16	1.8	12	1.4	10	1.2
	Output Torque Taccel	725	81.9	721	81.5	678	76.6	596	67.3
	Output Torque Trun	721	81.5	678	76.6	520	58.8	424	47.9
	Efficiency %	64		69		70		69	

Ratings for Size FS44

RATIO	CAPACITY	Input Speed , RPM							
		500		1000		2000		3000	
		Lb-In	Nm	Lb-In	Nm	Lb-In	Nm	Lb-In	Nm
5	Input Torque Taccel	192	21.7	175	19.8	150	17.0	129	14.6
	Input Torque Trun	177	20.0	150	17.0	111	12.6	92	10.4
	IT Thermal, Ttherm	176	20	150	17.0	90	10.2	66	7.5
	Output Torque Taccel	875	98.9	805	91.0	691	78.1	585	66.1
	Output Torque Trun	805	91.0	691	78.1	512	57.9	416	47.0
	Efficiency %	91		92		92		91	
7.5	Input Torque Taccel	159	17.9	144	16.2	127	14.3	109	12.4
	Input Torque Trun	147	16.6	126	14.2	94	10.6	78	8.8
	IT Thermal, Ttherm	146	16.5	126	14.2	77	8.7	46	5.2
	Output Torque Taccel	1058	120	980	111	860	97.2	734	82.9
	Output Torque Trun	980	111	860	97.2	639	72.2	521	58.9
	Efficiency %	89		91		91		90	
10	Input Torque Taccel	131	14.8	118	13.4	106	12.0	93	10.5
	Input Torque Trun	122	13.8	106	12.0	80	9.0	66	7.5
	IT Thermal, Ttherm	122	13.8	106	12.0	72	8.2	43	4.8
	Output Torque Taccel	1140	129	1065	120	955	108	822	92.9
	Output Torque Trun	1065	120	955	108	716	80.9	587	66.3
	Efficiency %	87		90		90		89	
15	Input Torque Taccel	105	11.8	95	10.7	82	9.3	76	8.6
	Input Torque Trun	99	11.2	82	9.3	61	6.9	54	6.1
	IT Thermal, Ttherm	99	11.2	82	9.3	60	6.8	36	4.1
	Output Torque Taccel	1324	150	1254	142	1081	122	989	112
	Output Torque Trun	1254	142	1081	122	810	91.5	707	79.8
	Efficiency %	84		88		88		87	
20	Input Torque Taccel	79	8.9	74	8.3	62	7.0	59	6.6
	Input Torque Trun	76	8.6	63	7.1	47	5.3	42	4.7
	IT Thermal, Ttherm	76	8.6	63	7.1	47	5.3	30	3.4
	Output Torque Taccel	1284	145	1237	140	1058	120	979	111
	Output Torque Trun	1237	140	1058	120	802	90.7	699	79.0
	Efficiency %	81		84		85		84	
25	Input Torque Taccel	62	7.0	60	6.7	41	4.6	41	4.6
	Input Torque Trun	61	6.9	63	7.1	38	4.3	34	3.8
	IT Thermal, Ttherm	61	6.9	63	7.1	38	4.3	28	3.2
	Output Torque Taccel	1259	142	1242	140	852	96.3	840	94.9
	Output Torque Trun	1242	140	1312	148	793	89.6	697	78.8
	Efficiency %	81		83		84		83	
30	Input Torque Taccel	54	6.1	53	6.0	44	5.0	39	4.4
	Input Torque Trun	51	5.8	50	5.6	34	3.8	28	3.2
	IT Thermal, Ttherm	51	5.8	45	5.1	34	3.8	23	2.6
	Output Torque Taccel	1197	135	1141	129	1064	120	933	105
	Output Torque Trun	1141	129	1064	120	816	92.2	666	75.3
	Efficiency %	74		71		80		79	
40	Input Torque Taccel	39	4.4	36	4.1	33	3.8	30	3.4
	Input Torque Trun	39	4.4	34	3.8	26	2.9	21	2.4
	IT Thermal, Ttherm	39	4.4	34	3.8	26	2.9	19	2.2
	Output Torque Taccel	1090	123	1087	123	1017	115	892	101
	Output Torque Trun	1087	123	1017	115	778	87.9	636	71.9
	Efficiency %	70		75		76		75	
50	Input Torque Taccel	31	3.5	29	3.3	27	3.0	24	2.7
	Input Torque Trun	31	3.5	27	3.1	21	2.3	17	1.9
	IT Thermal, Ttherm	31	3.5	27	3.1	21	2.3	17	1.9
	Output Torque Taccel	1059	120	1059	120	979	111	859	97.1
	Output Torque Trun	1059	120	979	111	750	84.8	612	69.2
	Efficiency %	68		72		73		72	
60	Input Torque Taccel	26	2.9	24	2.7	22	2.5	20	2.3
	Input Torque Trun	26	2.9	23	2.6	17	1.9	14	1.6
	IT Thermal, Ttherm	26	2.9	23	2.6	17	2.1	14	1.6
	Output Torque Taccel	1004	113	999	113	940	106	825	93.2
	Output Torque Trun	999	113	940	106	721	81.5	588	66.4
	Efficiency %	64		69		70		69	

Ratings for Size FS50

RATIO	CAPACITY	Input Speed , RPM							
		500		1000		2000		3000	
		Lb-In	Nm	Lb-In	Nm	Lb-In	Nm	Lb-In	Nm
5	Input Torque Taccel	257	29.0	234	26.4	201	22.7	106	12.0
	Input Torque Trun	236	26.7	201	22.7	149	16.8	123	13.9
	IT Thermal, Ttherm	236	26.6	187	21.1	92	10.4	66	7.5
	Output Torque Taccel	1168	132	1075	121	923	104	481	54.4
	Output Torque Trun	1075	121	923	104	684	77.3	556	62.8
	Efficiency %	91		92		92		91	
7.5	Input Torque Taccel	212	23.9	168	19.0	169	19.1	104	11.7
	Input Torque Trun	196	22.1	192	21.7	126	14.2	146	16.5
	IT Thermal, Ttherm	197	22.2	166	18.7	79	8.9	47	5.4
	Output Torque Taccel	1412	160	1149	130	1149	130	695	78.5
	Output Torque Trun	1308	148	1308	148	853	96.4	981	111
	Efficiency %	89		91		91		90	
10	Input Torque Taccel	175	19.8	158	17.9	142	16.0	124	14.0
	Input Torque Trun	163	18.5	142	16.0	106	12.0	88	10.0
	IT Thermal, Ttherm	164	18.5	142	16.0	74	8.3	44	4.9
	Output Torque Taccel	1522	172	1422	161	1275	144	1098	124
	Output Torque Trun	1422	161	1275	144	956	108	784	88.6
	Efficiency %	87		90		90		89	
15	Input Torque Taccel	140	15.8	127	14.3	116	13.1	102	11.5
	Input Torque Trun	133	15.0	115	13.0	88	9.9	73	8.2
	IT Thermal, Ttherm	132	14.9	115	13.0	62	7.0	37	4.2
	Output Torque Taccel	1768	200	1675	189	1524	172	1321	149
	Output Torque Trun	1675	189	1524	172	1154	130	944	107
	Efficiency %	84		88		88		87	
20	Input Torque Taccel	105	11.9	98	11.1	88	9.9	78	8.8
	Input Torque Trun	101	11.5	89	10.0	67	7.6	56	6.3
	IT Thermal, Ttherm	102	11.5	89	10.0	49	5.6	30	3.4
	Output Torque Taccel	1715	194	1652	187	1491	168	1307	148
	Output Torque Trun	1652	187	1491	168	1143	129	934	106
	Efficiency %	81		84		85		84	
25	Input Torque Taccel	83	9.4	80	9.0	71	8.0	63	7.1
	Input Torque Trun	82	9.3	71	8.1	54	6.1	45	5.1
	IT Thermal, Ttherm	82	9.3	71	8.0	46	5.2	29	3.2
	Output Torque Taccel	1682	190	1659	187	1488	168	1302	147
	Output Torque Trun	1659	187	1488	168	1138	129	930	105
	Efficiency %	81		83		84		83	
30	Input Torque Taccel	72	8.1	64	7.2	59	6.7	53	6.0
	Input Torque Trun	68	7.7	60	6.8	45	5.1	38	4.3
	IT Thermal, Ttherm	69	7.7	60	6.8	37	4.2	23	2.6
	Output Torque Taccel	1598	181	1524	172	1422	161	1246	141
	Output Torque Trun	1524	172	1422	161	1089	123	890	101
	Efficiency %	74		79		80		79	
40	Input Torque Taccel	52	5.8	48	5.4	45	5.1	40	4.5
	Input Torque Trun	52	5.8	45	5.1	34	3.9	28	3.2
	IT Thermal, Ttherm	52	5.8	45	5.1	31	3.5	20	2.2
	Output Torque Taccel	1455	164	1452	164	1359	154	1192	135
	Output Torque Trun	1452	164	1359	154	1039	117	850	96.1
	Efficiency %	70		75		76		75	
50	Input Torque Taccel	41	4.7	39	4.4	36	4.1	32	3.6
	Input Torque Trun	41	4.7	36	4.1	27	3.1	23	2.6
	IT Thermal, Ttherm	41	4.7	36	4.1	27	3.1	18	2.0
	Output Torque Taccel	1415	160	1415	160	1308	148	1148	130
	Output Torque Trun	1415	160	1308	148	1002	113	818	92.4
	Efficiency %	68		72		73		72	
60	Input Torque Taccel	35	3.9	32	3.6	30	3.4	19	2.2
	Input Torque Trun	35	3.9	30	3.4	23	2.6	27	3.0
	IT Thermal, Ttherm	35	3.9	30	3.4	23	2.8	16	1.8
	Output Torque Taccel	1341	152	1334	151	1256	142	786	88.8
	Output Torque Trun	1334	151	1256	142	963	109	1102	125
	Efficiency %	64		69		70		69	

Ratings for Size FS60

RATIO	CAPACITY	Input Speed , RPM							
		500		1000		2000		3000	
		Lb-In	Nm	Lb-In	Nm	Lb-In	Nm	Lb-In	Nm
5	Input Torque Taccel	443	50.1	398	45.0	327	37.0	275	31.1
	Input Torque Trun	403	45.5	327	36.9	237	26.8	192	21.8
	IT Thermal, Ttherm	340	38.4	191	21.6	94	10.7	66	7.5
	Output Torque Taccel	2017	228	1833	207	1503	170	1245	141
	Output Torque Trun	1833	207	1503	170	1091	123	872	98.5
	Efficiency %	91		92		92		91	
7.5	Input Torque Taccel	365	41.3	327	37.0	276	31.2	232	26.2
	Input Torque Trun	334	37.8	275	31.1	200	22.6	163	18.4
	IT Thermal, Ttherm	278	31.4	170	19.2	80	9.1	49	5.5
	Output Torque Taccel	2439	276	2232	252	1876	212	1554	176
	Output Torque Trun	2232	252	1876	212	1359	154	1092	123
	Efficiency %	89		91		91		90	
10	Input Torque Taccel	302	34.1	270	30.5	224	25.3	197	22.2
	Input Torque Trun	280	31.6	224	25.3	169	19.1	139	15.7
	IT Thermal, Ttherm	236	26.6	153	17.3	76	8.6	45	5.1
	Output Torque Taccel	2625	297	2433	275	2013	227	1744	197
	Output Torque Trun	2433	275	2013	227	1523	172	1228	139
	Efficiency %	87		90		90		89	
15	Input Torque Taccel	241	27.2	217	24.6	158	17.8	124	14.1
	Input Torque Trun	227	25.7	158	17.8	126	14.2	101	11.4
	IT Thermal, Ttherm	194	21.9	128	14.4	63	7.1	38	4.3
	Output Torque Taccel	3044	344	2869	324	2079	235	1616	183
	Output Torque Trun	2869	324	2079	235	1661	188	1309	148
	Efficiency %	84		88		88		87	
20	Input Torque Taccel	181	20.5	168	19.0	144	16.3	97	11.0
	Input Torque Trun	174	19.6	63	7.1	91	10.3	78	8.8
	IT Thermal, Ttherm	165	18.6	63	7.1	51	5.7	31	3.5
	Output Torque Taccel	2954	334	2830	320	2445	276	1622	183
	Output Torque Trun	2830	320	1058	120	1546	175	1299	147
	Efficiency %	81		84		85		84	
25	Input Torque Taccel	143	16.2	136	15.4	97	11.0	82	9.2
	Input Torque Trun	140	15.8	98	11.0	72	8.2	62	7.0
	IT Thermal, Ttherm	140	15.8	92	10.4	48	5.4	29	3.3
	Output Torque Taccel	2897	327	2837	321	2034	229.8	1688	191
	Output Torque Trun	2837	321	2034	230	1520	171.7	1279	145
	Efficiency %	81		83		84		83	
30	Input Torque Taccel	124	14.0	106	12.0	84	9.5	78	8.9
	Input Torque Trun	113	12.8	85	9.6	65	7.3	59	6.7
	IT Thermal, Ttherm	113	12.8	74	8.4	38	4.3	24	2.7
	Output Torque Taccel	2753	311	2524	285	2023	229	1850	209
	Output Torque Trun	2524	285	2023	229	1548	175	1396	158
	Efficiency %	74		79		80		79	
40	Input Torque Taccel	89	10.1	83	9.3	68	7.6	59	6.6
	Input Torque Trun	88	10.0	68	7.7	50	5.7	43	4.9
	IT Thermal, Ttherm	88	10.0	62	7.0	32	3.6	20	2.3
	Output Torque Taccel	2510	284	2488	281	2052	232	1750	198
	Output Torque Trun	2488	281	2052	232	1530	173	1285	145
	Efficiency %	70		75		76		75	
50	Input Torque Taccel	71	8.0	67	7.6	59	6.7	51	5.8
	Input Torque Trun	71	8.0	55	6.3	42	4.8	36	4.0
	IT Thermal, Ttherm	71	8.0	55	6.2	28	3.2	18	2.0
	Output Torque Taccel	2427	274	2424	274	2150	243	1825	206
	Output Torque Trun	2424	274	2004	226	1539	174	1282	145
	Efficiency %	68		72		73		72	
60	Input Torque Taccel	60	6.8	55	6.2	47	5.4	43	4.8
	Input Torque Trun	59	6.7	48	5.4	36	4.1	30	3.4
	IT Thermal, Ttherm	59	6.7	48	5.4	25	3.1	16	1.8
	Output Torque Taccel	2314	261	2286	258	1991	225	1753	198
	Output Torque Trun	2286	258	1991	225	1529	173	1231	139
	Efficiency %	64		69		70		69	

Ratings for Size FS76

RATIO	CAPACITY	Input Speed , RPM							
		500		1000		2000		3000	
		Lb-In	Nm	Lb-In	Nm	Lb-In	Nm	Lb-In	Nm
5	Input Torque Taccel	922	104.2	811	91.7	635	71.8	534	60.3
	Input Torque Trun	820	92.7	634	71.7	456	51.5	361	40.8
	IT Thermal, Ttherm	389	44.0	219	24.7	108	12.2	66	7.5
	Output Torque Taccel	4196	474	3732	422	2918	330	2417	273
	Output Torque Trun	3732	422	2918	330	2096	237	1634	185
	Efficiency %	91		92		92		91	
7.5	Input Torque Taccel	760	85.9	673	76.0	548	61.9	459	51.9
	Input Torque Trun	688	77.7	545	61.6	392	44.3	316	35.7
	IT Thermal, Ttherm	318	36.0	195	22.0	92	10.4	56	6.3
	Output Torque Taccel	5076	574	4591	519	3718	420	3082	348
	Output Torque Trun	4591	519	3718	420	2658	300	2118	239
	Efficiency %	89		91		91		90	
10	Input Torque Taccel	632	71.4	560	63.3	469	53.0	275	31.0
	Input Torque Trun	580	65.5	468	52.9	340	38.4	393	44.4
	IT Thermal, Ttherm	269	30.4	175	19.8	87	9.8	51	5.8
	Output Torque Taccel	5501	622	5042	570	4213	476	2434	275
	Output Torque Trun	5042	570	4213	476	3054	345	3484	394
	Efficiency %	87		90		90		89	
15	Input Torque Taccel	505	57.1	451	50.9	347	39.2	324	36.6
	Input Torque Trun	471	53.2	347	39.2	258	29.2	226	25.6
	IT Thermal, Ttherm	222	25.1	146	16.5	72	8.2	43	4.9
	Output Torque Taccel	6379	721	5948	672	4574	517	4206	475
	Output Torque Trun	5948	672	4574	517	3406	385	2938	332
	Efficiency %	84		88		88		87	
20	Input Torque Taccel	380	43.0	350	39.5	262	29.6	249	28.1
	Input Torque Trun	361	40.8	265	29.9	198	22.4	174	19.6
	IT Thermal, Ttherm	188	21.3	109	12.4	58	6.5	36	4.0
	Output Torque Taccel	6189	699	5878	664	4445	502	4155	470
	Output Torque Trun	5878	664	4445	502	3370	381	2905	328
	Efficiency %	81		84		85		84	
25	Input Torque Taccel	300	33.9	284	32.0	219	24.7	200	22.7
	Input Torque Trun	292	32.9	221	24.9	167	18.9	140	15.8
	IT Thermal, Ttherm	184	20.8	105	11.9	54	6.1	33	3.8
	Output Torque Taccel	6081	687	5904	667	4592	519	4140	468
	Output Torque Trun	5904	667	4592	519	3502	396	2896	327
	Efficiency %	81		83		84		83	
30	Input Torque Taccel	260	29.3	228	25.8	198	22.3	168	19.0
	Input Torque Trun	244	27.5	199	22.5	145	16.4	117	13.3
	IT Thermal, Ttherm	136	15.3	85	9.6	44	4.9	27	3.1
	Output Torque Taccel	5778	653	5426	613	4738	535	3963	448
	Output Torque Trun	5426	613	4738	535	3474	393	2768	313
	Efficiency %	74		79		80		79	
40	Input Torque Taccel	187	21.1	172	19.4	149	16.8	127	14.4
	Input Torque Trun	184	20.7	150	17.0	109	12.4	89	10.0
	IT Thermal, Ttherm	118	13.4	71	8.0	36	4.1	23	2.6
	Output Torque Taccel	5260	594	5169	584	4524	511	3791	428
	Output Torque Trun	5169	584	4524	511	3319	375	2643	299
	Efficiency %	70		75		76		75	
50	Input Torque Taccel	149	16.8	121	13.6	120	13.5	102	11.5
	Input Torque Trun	147	16.6	139	15.7	88	9.9	71	8.0
	IT Thermal, Ttherm	111	12.5	63	7.1	32	3.6	21	2.3
	Output Torque Taccel	5085	575	4360	493	4360	493	3651	413
	Output Torque Trun	5035	569	5035	569	3198	361	2545	288
	Efficiency %	68		72		73		72	
60	Input Torque Taccel	125	14.2	114	12.9	100	11.3	85	9.6
	Input Torque Trun	123	13.9	101	11.4	73	8.3	59	6.7
	IT Thermal, Ttherm	98	11.1	57	6.4	29	3.6	19	2.1
	Output Torque Taccel	4849	548	4749	537	4186	473	3508	396
	Output Torque Trun	4749	537	4189	473	3074	347	2443	276
	Efficiency %	64		69		70		69	

SERVO MOTOR INSTALLATION

THE COUPLING'S THREE PIECE DESIGN ALLOWS THE HUBS TO BE INSTALLED ON EACH INDIVIDUAL SHAFT, THEN JOINED AXIALLY.

MOUNT THE MOTOR'S COUPLING HALF ON THE MOTOR SHAFT. POSITION TO THE DIMENSION SHOWN FOR THE APPROPRIATE ASSEMBLY.

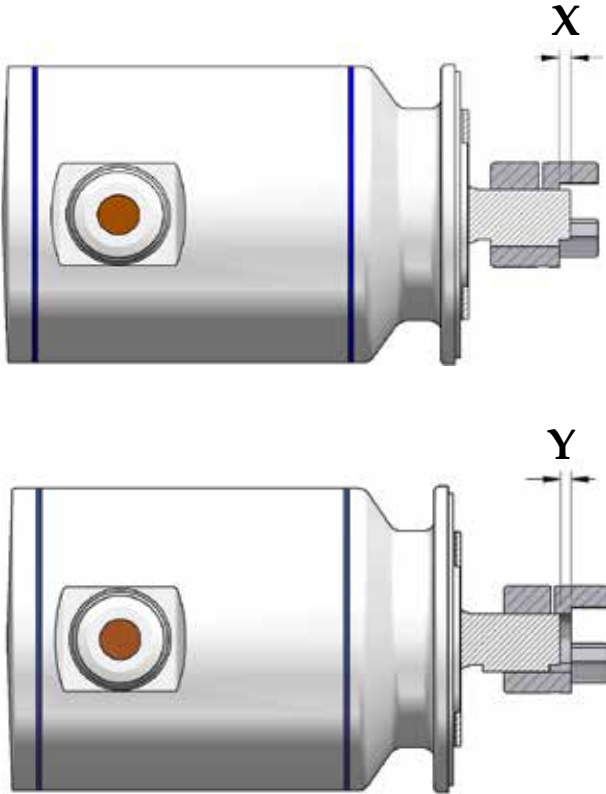

Reducer Size	Kollmorgen	Allen-Bradley	"X" Shaft protrudes beyond coupling hub (mm)	"Y" Shaft protrudes beyond coupling hub (mm)	Setscrew Torque Nm	
39, 44, 50	AKMH3 - All faces		0	0	10.5	
	AKMH4-BK, BN, DK, DN		0	0	10.5	
	AKMH4-AC, AN, CC, CN			3	10.5	
	AKMH5-AC, AN			1	10.5	
	AKMH5-BK, BN, DK, DN			2	10.5	
		MPS-A/B 330P		1	10.5	
60	AKMH4-BK, BN, DK, DN		1		10.5	
	AKMH4-AC, AN, CC, CN			5	10.5	
	AKMH5-AC, AN			1	10.5	
	AKMH5-BK, BN, DK, DN			2	10.5	
	AKMH6-AC, AN, CC, CN				4	25
	AKMH6-DK, DN			2		10.5
			MPS-A/B 4540F		1	10.5
		MPS-A/B 560F		3	10.5	
76	AKMH4-BK, BN, DK, DN		2		10.5	
	AKMH4-AC, AN, CC, CN			4	10.5	
	AKMH5-AC, AN			0	10.5	
	AKMH5-BK, BN, DK, DN			1	10.5	
	AKMH6-AC, AN, CC, CN				4	25
	AKMH6-DK, DN			1		25
			MPS-A/B 4540F		0	10.5
			MPS-A/B 560F		2	10.5

FOR SOME MOTORS (PARTICULARLY FACE-MOUNT MOTORS), IT WILL BE NECESSARY TO REMOVE THE MOTOR PLATE FROM THE MOTOR ADAPTER, FASTEN THE PLATE TO THE MOTOR, THEN MOUNT THE MOTOR AND PLATE BACK TO THE REDUCER.

SCREW TORQUES (Nm):	
M6	8 - 9.6
M8	24 - 30
M10	38 - 46
5/16 - 18	24 - 29
3/8-16	27 - 40

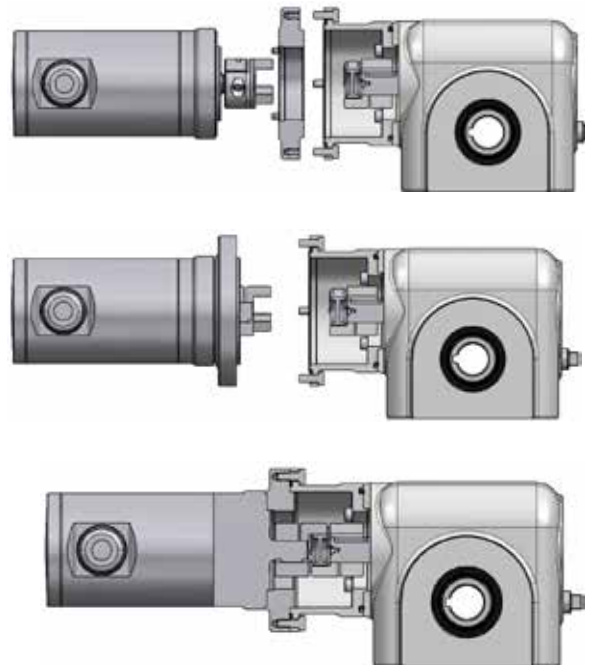

SERVO MOTOR INSTALLATION

MOUNT THE MOTOR'S COUPLING HALF ON THE MOTOR SHAFT. POSITION TO THE DIMENSION SHOWN FOR THE APPROPRIATE ASSEMBLY.

IF NECESSARY TO REPOSITION THE COUPLING HALF MOUNTED TO THE GEARBOX

1. REMOVE THE (4) M6 SOCKET CAP SCREWS.
2. REMOVE THE MOTOR ADAPTER.
3. LOOSEN AND REPOSITION COUPLING AS REQUIRED.
4. TIGHTEN THE COUPLING SETSCREW.
5. REPLACE THE MOTOR ADAPTER; TIGHTEN SCREWS TO 16-20 Nm

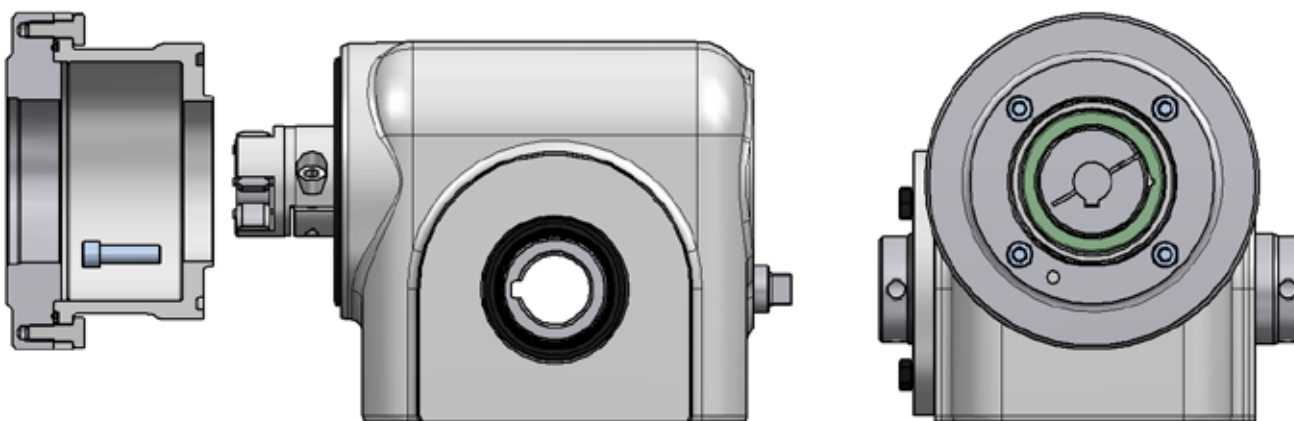

SHRINK DISC / HOLLOW SHAFT COVER ASSEMBLY

THE SHRINK DISC / HOLLOW SHAFT COVER IS SHIPPED LOOSE, TO BE ASSEMBLED AFTER THE REDUCER IS MOUNTED AND THE CUSTOMER'S SHAFT (AND SHRINK DISC, IF USED) IS ASSEMBLED.

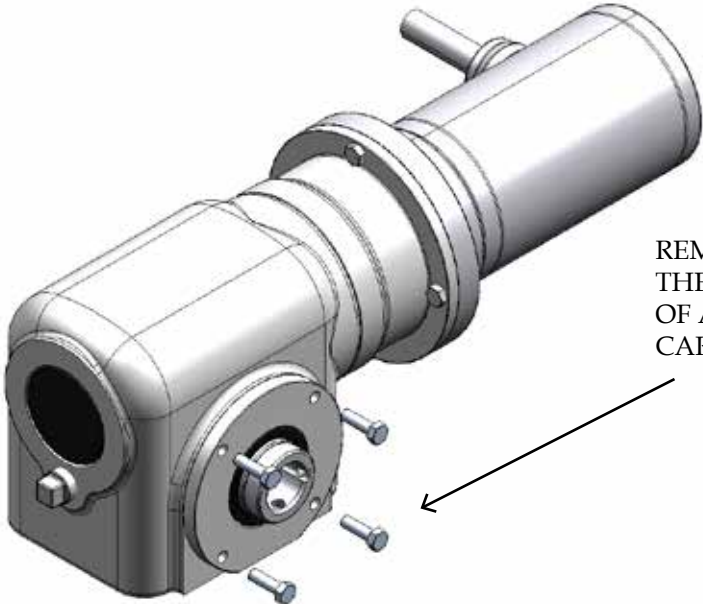

REMOVE THE FOUR CARRIER BOLTS. WHEN UNBOLTED, THE CARRIER WILL BE HELD IN PLACE BY THE FRICTION OF AN INTERNAL O-RING, BUT TAKE CARE THAT THE CARRIER STAYS IN PLACE.

APPLY A LIGHT BEAD OF NSF 51 LIST, SPACE FILLING SEALER SUCH AS DOW CORNING 732 SEALANT* INSIDE THE COVER'S FLANGE. APPLY SO THAT SEALANT WON'T MIGRATE ONTO THE SHAFT'S OIL SEAL SURFACE WHEN ASSEMBLED.

*IT IS THE RESPONSIBILITY OF THE USER TO SELECT SEALANT THAT IS SUITABLE FOR THE OPERATING CONDITIONS.

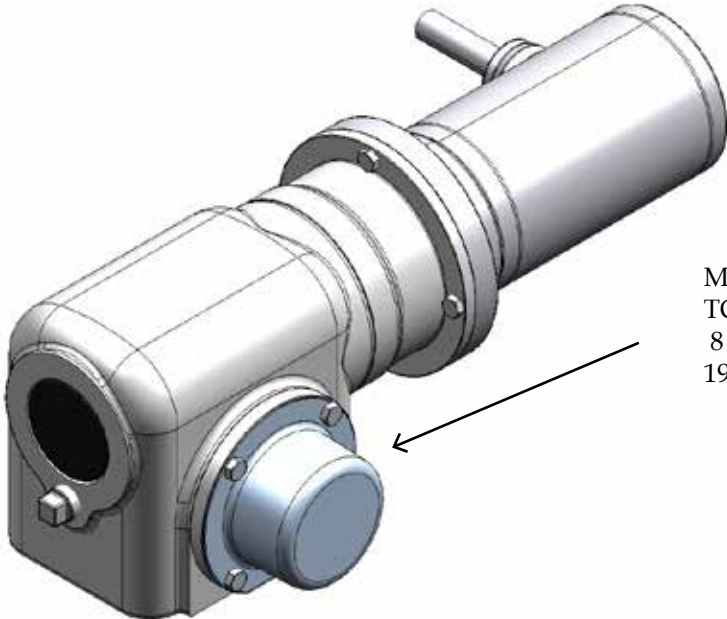

MOUNT THE COVER. REINSTALL THE CARRIER BOLTS. TORQUE IN ALTERNATING PATTERN TO:
8 - 9.6 Nm (SIZE 39, 44, 50, 60)
19-23 Nm (SIZE 76)

Cone Drive **Stainless Steel** Planetary Gearhead



- 300 Series stainless steel construction
- IP 66 rating
- Viton® seals
- Dimensional drop in for most planetary manufacturers
- Frame sizes 70 / 90 / 120

Planetary information - 12 DIGIT CODE

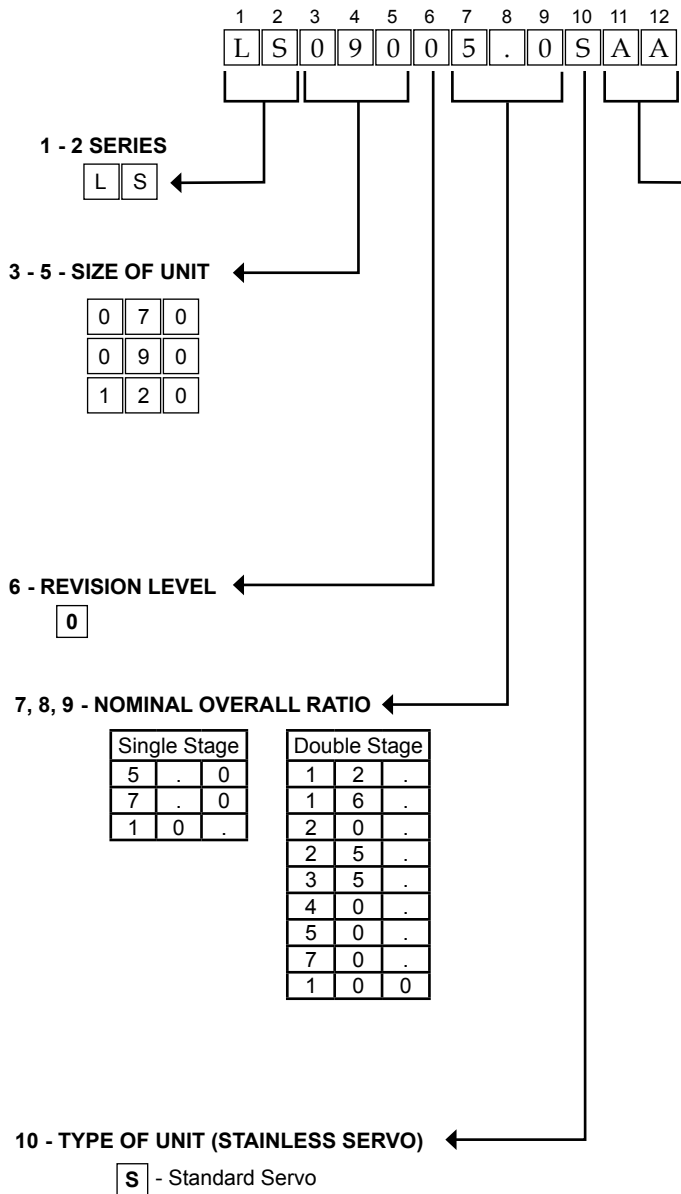

11 - 12 - SERVO MOTOR
 (see motor tables below for letter codes)
 (Custom motor adaptation available upon request)

Allen Bradley		
A	A	MPS-A / B330P
A	B	MPS-A / B4540F, VPS-A1304D
A	C	MPS-A / B560F, VPS-B1653D
A	D	MPF-A/B310-A/B320-A/B330
A	E	MPF-A/B430
A	F	MPF-A/B4530-A/B4540
A	G	MPF-A/B540

KOLLMORGEN		
K	A	AKMH3 Code AC, AN
K	B	AKMH3 Code CC, CN
K	C	AKMH4 Code AC, AN
K	D	AKMH4 Code BK, BN
K	E	AKMH4 Code CC, CN
K	F	AKMH4 Code DK, DN
K	H	AKMH5 Code AC, AN
K	I	AKMH5 Code BK, BN
K	J	AKMH5 Code DK, DN
K	K	AKMH5 Code CC, CN
K	L	AKMH5 Code GC, GN
K	M	AKMH5 Code HC, HN
K	P	AKMH6 Code AC, AN
K	Q	AKMH6 Code CC, CN
K	R	AKMH6, Code DK, DN (NEMA Small C-Face)
K	S	AKM21/22/23/24-BN
K	T	AKM21/22/23/24-CK
K	U	AKM21/22/23/24-EN
K	V	AKM31/32/33-AN
K	W	AKM31/32/33-CN
K	X	AKM41/42/43/44-AN
K	Y	AKM41/42/43/44-BK
K	Z	AKM41/42/43/44-CN
K	1	AKM41/42/43/44-EK
K	2	AKM51/52/53/54-AN
K	3	AKM51/52/53/54-BK
K	4	AKM51/52/53/54-CN
K	5	AKM51E-DK
K	6	AKM51/52/53/54-BK
K	7	AKM62/63/64/65-AC

BALDOR		
B	A	SSBSM50N
B	B	SSBSM63N
B	C	SSBSM80C/N

Cone Drive's **STAINLESS STEEL REDUCERS**

are designed for sterile manufacturing environments. The smooth housings allow for easy cleaning and bacteria free surfaces.

Both the **WORM** and **PLANETARY** reducers are designed to be compliant with government regulations and sanitary standards:

FSMA / 3-A / HACCP / EHEDG

RATIOS	GEAR STAGES		Output Torque by Gearhead Size					
			70		90		120	
			T2N	TMAX	T2N	TMAX	T2N	TMAX
3	1	lb. in.	177	319	354	620	885	1593
		Nm.	20	36	40	70	100	180
4	1	lb. in.	230	389	478	885	1062	1770
		Nm.	26	44	54	100	120	200
5	1	lb. in.	230	389	478	885	1062	1770
		Nm.	26	44	54	100	120	200
7	1	lb. in.	230	389	478	885	1062	1770
		Nm.	26	44	54	100	120	200
10	1	lb. in.	142	212	354	664	929	1593
		Nm.	16	24	40	75	105	180
12	2	lb. in.	319	398	708	885	1505	1903
		Nm.	36	45	80	100	170	215
16	2	lb. in.	372	460	885	1106	1859	2257
		Nm.	42	52	100	125	210	255
20	2	lb. in.	372	460	885	1106	1859	2257
		Nm.	42	52	100	125	210	255
25	2	lb. in.	372	460	885	1106	1859	2257
		Nm.	42	52	100	125	210	255
35	2	lb. in.	372	460	885	1106	1859	2257
		Nm.	42	52	100	125	210	255
40	2	lb. in.	372	460	885	1106	1859	2257
		Nm.	42	52	100	125	210	255
50	2	lb. in.	372	460	885	1106	1859	2257
		Nm.	42	52	100	125	210	255
70	2	lb. in.	372	460	885	1106	1859	2257
		Nm.	42	52	100	125	210	255
100	2	lb. in.	142	212	354	664	929	1593
		Nm.	16	24	40	75	105	180

INERTIA (at the input)	RATIO	GEAR STAGES		SIZE		
				70	90	120
	3	1	kgcm ²	0.45	1.37	6.54
			lb-in ²	0.154	0.468	1.640
			kgcm ²	0.38	1.14	4.8
			lb-in ²	0.130	0.390	1.640
			kgcm ²	0.36	1.05	4.05
			lb-in ²	0.123	0.359	1.384
	4	1	kgcm ²	0.35	0.97	3.4
			lb-in ²	0.120	0.331	1.162
			kgcm ²	0.34	0.93	3.10
			lb-in ²	0.116	0.319	1.059
			kgcm ²	0.38	1.14	4.8
			lb-in ²	0.130	0.390	1.640
5	1	kgcm ²	0.38	1.14	4.8	
		lb-in ²	0.130	0.390	1.640	
		kgcm ²	0.36	1.05	4.05	
		lb-in ²	0.123	0.359	1.384	
		kgcm ²	0.36	1.05	4.05	
		lb-in ²	0.123	0.359	1.384	
7	1	kgcm ²	0.36	1.05	4.05	
		lb-in ²	0.123	0.359	1.384	
		kgcm ²	0.35	0.97	3.4	
		lb-in ²	0.120	0.331	1.162	
		kgcm ²	0.34	0.93	3.10	
		lb-in ²	0.116	0.319	1.059	
10	1	kgcm ²	0.34	0.93	3.10	
		lb-in ²	0.116	0.319	1.059	
		kgcm ²	0.34	0.93	3.10	
		lb-in ²	0.116	0.319	1.059	
		kgcm ²	0.34	0.93	3.10	
		lb-in ²	0.116	0.319	1.059	
12	2	kgcm ²	0.34	0.93	3.10	
		lb-in ²	0.116	0.319	1.059	
		kgcm ²	0.34	0.93	3.10	
		lb-in ²	0.116	0.319	1.059	
		kgcm ²	0.34	0.93	3.10	
		lb-in ²	0.116	0.319	1.059	
16	2	kgcm ²	0.34	0.93	3.10	
		lb-in ²	0.116	0.319	1.059	
		kgcm ²	0.34	0.93	3.10	
		lb-in ²	0.116	0.319	1.059	
		kgcm ²	0.34	0.93	3.10	
		lb-in ²	0.116	0.319	1.059	
20	2	kgcm ²	0.34	0.93	3.10	
		lb-in ²	0.116	0.319	1.059	
		kgcm ²	0.34	0.93	3.10	
		lb-in ²	0.116	0.319	1.059	
		kgcm ²	0.34	0.93	3.10	
		lb-in ²	0.116	0.319	1.059	
25	2	kgcm ²	0.34	0.93	3.10	
		lb-in ²	0.116	0.319	1.059	
		kgcm ²	0.34	0.93	3.10	
		lb-in ²	0.116	0.319	1.059	
		kgcm ²	0.34	0.93	3.10	
		lb-in ²	0.116	0.319	1.059	
35	2	kgcm ²	0.34	0.93	3.10	
		lb-in ²	0.116	0.319	1.059	
		kgcm ²	0.34	0.93	3.10	
		lb-in ²	0.116	0.319	1.059	
		kgcm ²	0.34	0.93	3.10	
		lb-in ²	0.116	0.319	1.059	
40	2	kgcm ²	0.34	0.93	3.10	
		lb-in ²	0.116	0.319	1.059	
		kgcm ²	0.34	0.93	3.10	
		lb-in ²	0.116	0.319	1.059	
		kgcm ²	0.34	0.93	3.10	
		lb-in ²	0.116	0.319	1.059	
50	2	kgcm ²	0.34	0.93	3.10	
		lb-in ²	0.116	0.319	1.059	
		kgcm ²	0.34	0.93	3.10	
		lb-in ²	0.116	0.319	1.059	
		kgcm ²	0.34	0.93	3.10	
		lb-in ²	0.116	0.319	1.059	
70	2	kgcm ²	0.34	0.93	3.10	
		lb-in ²	0.116	0.319	1.059	
		kgcm ²	0.34	0.93	3.10	
		lb-in ²	0.116	0.319	1.059	
		kgcm ²	0.34	0.93	3.10	
		lb-in ²	0.116	0.319	1.059	
100	2	kgcm ²	0.34	0.93	3.10	
		lb-in ²	0.116	0.319	1.059	
		kgcm ²	0.34	0.93	3.10	
		lb-in ²	0.116	0.319	1.059	
		kgcm ²	0.34	0.93	3.10	
		lb-in ²	0.116	0.319	1.059	

	GEAR STAGES		SIZE		
			70	90	120
Emergency Stop			2 x T2N		
Degree of Protection			IP66		
Backlash	1	arc-mins	< 10	< 10	< 8
	2	arc-mins	< 14	< 14	< 12
Allowable Radial Load ¹		lbs.	204	337	674
		N	910	1500	3000
Allowable Axial Load ¹		lbs.	112	225	337
		N	500	1000	1500
Efficiency	1	%	94		
	2	%	92		
Lifetime		Hours	30,000		
Weight	1	lbs.	4.4	8.6	19.4
		kg.	2.0	3.9	8.8
	2	lbs.	5.1	10.3	24.0
		kg.	2.3	4.7	10.9

Planetary information - Series LS Dimensions

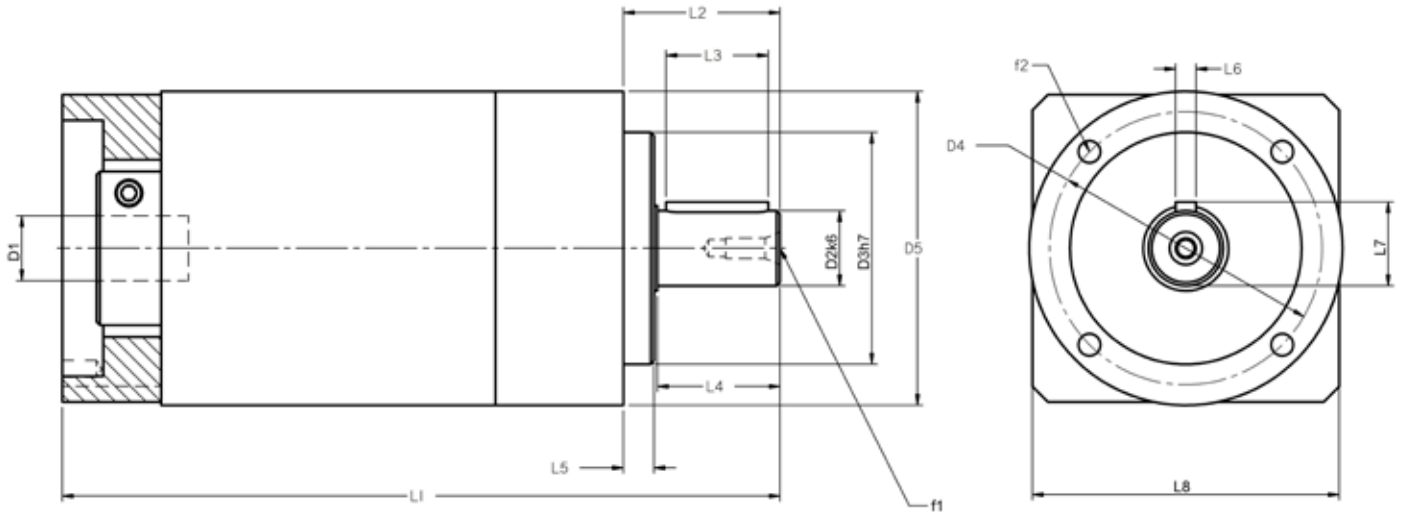

LS Series		UNIT SIZE					
		70		90		120	
		mm	inch	mm	inch	mm	inch
D1 min standard	motor shaft diameter	14	0.551	19	0.748	24	0.945
D1 max standard	motor shaft diameter	16	0.63	24	0.945	32	1.26
D2 k6	output shaft diameter	16	0.63	22	0.866	32	1.26
D3 h7	pilot diameter	52	2.047	68	2.677	90	3.543
D4	bolt circle diameter	62	2.441	80	3.15	108	4.252
D5	housing diameter	70	2.756	92	3.622	122	4.803
f1	shaft thread	M5 x 12		M6 x 16		M10 x 22	
f2	mounting hole	M6 x 12		M6 x 14		M8 x 18	
L1 1-stage	gearhead length	131	5.157	174	6.85	232	9.134
L1 2-stage		153	6.024	207	8.15	271	10.669
L2	shaft length	36	1.417	46	1.811	70	2.756
L3	key length	25	0.984	30	1.181	50	1.969
L4	useable shaft length	28	1.102	36	1.417	58	2.283
L5	pilot height	7	0.276	9	0.354	11	0.433
L6	key width	5	0.197	6	0.236	8	0.315
L7	key height	18	0.709	24.6	0.969	34.8	1.37

LUBRICATION, INSTALLATION, OPERATION & MAINTENANCE INSTRUCTIONS FOR STAINLESS STEEL CONE DRIVE SPEED REDUCERS

Cone Drive double-enveloping worm gear speed reducers are used throughout Industry to provide smooth and quiet

speed reduction. When properly selected, applied and maintained, they will provide optimum performance.

IMPORTANT:

In any applications of Cone Drive Products where breakage, damage, disconnection, any other malfunction of any drive train component, or excessive wear could result in personal

injury or property damage, a fail safe device capable of stopping and holding the load in the event of such an occurrence must be incorporated after the drive train.

THE FOLLOWING INFORMATION IS FOR YOUR PROTECTION. PLEASE READ CAREFULLY.

1. Do not attempt to install or operate this reducer until all of these instructions are read and thoroughly understood. If you have any questions, please contact Cone Drive.
2. The horsepower or output torque capacity of this reducer and the service factor (maximum allowable operating cycle) are stamped on the reducer nameplate. These values are not to be exceeded as overloading can result in reducer failure. Exceeding the rating and duty cycle will void the warranty. Please contact Cone Drive with any questions regarding rating and service factors.
3. Each reducer is specifically arranged to operate at the input speed specified on the nameplate. If the input speed is not specified by the customer, it is set up for 1750 RPM and service factor
3. Do not operate the reducer at speeds or under service other than specified on the nameplate without contacting Cone Drive for specific instructions on oil level location and bearing settings.
4. Do not alter the reducer without approval from Cone Drive.
5. This reducer has moving mechanical components and connected electrical devices, operating under high voltage to achieve its intended purpose. Operation and repair should only be done by qualified personnel.
6. Before servicing a speed reducer, the main electrical disconnect must be moved to and locked in the off-position. The person performing the work should post on that disconnect a warning to others not to turn on the power.
7. It is normal for the reducer to operate at a housing temperature of up to 200°F. To prevent burns, proper guards or shields must be provided by the purchaser or user to prevent personnel from touching the reducer.
8. Cone Drive products are furnished without guard covers. It is the responsibility of the purchase or user to provide guards for all exposed shafting, couplings, sprockets, sheaves, belts, chains, clutches, and any other moving parts in accordance with current local, state and federal requirements.
9. Failure to follow the instructions contained in this bulletin may result in unit failure, property damage or personal injury.

LUBRICATION, INSTALLATION, OPERATION & MAINTENANCE INSTRUCTIONS FOR STAINLESS STEEL CONE DRIVE SPEED REDUCERS

INSTALLATION

1. The speed reducer must be securely mounted to a rigid foundation or base plate, flat enough to mate with the underside of the reducer housing, so as to not create an unsanitary trap.
2. Bolt the reducer to the foundation or mounting base using metric bolts that correspond to the threaded holes in the reducer housing. Be sure to use a bolt in all available threaded mounting holes. Mount the reducer using bolts of minimum SAE Grade A2, Property Class 70, 304 Stainless Steel.
3. Couplings, sheaves and sprockets should be mounted on the reducer shafts carefully. Do not pound or hammer them onto the shafts as this will damage bearings and oil seals. Angular and axial alignment of the output shaft to the rotating machine interface is critical to prevent premature output seal leaks.
4. Sprockets and sheaves should be mounted as close to the reducer as possible and "V" belts and chains adjusted to the proper tension to keep bearing loading and shaft deflection to a minimum.

Too much tension in belts and improper location of sheaves

and sprockets will lead to excessive chain pull, bearing wear and shaft deflection. For specific information on chain pull capacity, shaft stress and bearing life please contact Cone Drive.

5. Before starting motor review motor rotation, reducer rotation and required direction of driven machine to ensure that the motor is wired for proper direction of rotation. In many instances a machine must run in one direction and failure to wire the motor properly can result in damage to the driven machine.

6. **Note: only use the approved lubricants if oil level top-off is necessary, as the factory filled PAG oil is not compatible with other oil types.** Stainless steel speed reducers ship factory filled with oil and grease. For lubrication guidelines, see the Approved Lubricants and Lubrication Quantities tables in the maintenance section.

7. The speed reducer must be securely mounted to a rigid flat foundation or base plate, either directly to the speed reducer or via the provided mounting feet. Note: stainless steel speed reducers are built for universal mounting, ready to mount in any position.

START-UP

1. After the reducer has been properly mounted, aligned and lubricated, it is ready for start-up.
2. Make sure driven machine is clear of all obstructions and all safety guards and covers are in place, according to appropriate local, state and federal requirements. If possible, turn motor shaft by hand to confirm drive system is operating freely and in correct direction of rotation.

3. Jog motor to confirm proper rotation.

4. Operate reducer with minimum load for approximately 15 minutes (in both directions if applicable) to seat gears, bearings, and oil seals.

OPERATION

1. All reducers require a few hours of "run-in" under load to achieve optimum efficiency. During this initial run-in the reducer will probably run warmer than normal and draw more current than after the run-in period. Reducers operating at a very low load or speed will take much longer to run-in and even if operated continuously at low load or speed may never achieve the efficiency that they would if operated at or near their catalog rating.

2. **IMPORTANT:** Normal reducer operating temperature measured at the oil sump area of the housing should not exceed 200° F. Excessive oil sump temperature is indicative of overloading, misalignment, or improper or marginal lubrication. Continuous operation of the reducer with the oil sump temperature above 200° F will result in premature breakdown of the oil and reduce the useful life of the reducer or result in premature failure.

MAINTENANCE

1. All reducers and foundation bolts should be checked for tightness after three (3) months of service and annually thereafter.
2. If a reducer is to be repaired, contact Cone Drive for detailed instructions, drawings, parts lists, etc. If it is necessary field service is available.
3. If a reducer is to be returned, contact Cone Drive for instructions and a return material authorization (CASE) number.

foodgrade synthetic lubricant. They are "Lubricated for Life" and require no routine maintenance in service. In the event of a major overhaul involving strip-down and reassembly of the gear unit, refer to Table 1 for a list of approved lubricants. Lubricant quantities are given in Tables 2 & 3.

If switching to the alternative lubricant, care should be taken to thoroughly flush out all of the old lubricant before filling with new lubricant. Mixing of different lubricants can result in degraded performance or failure.

LUBRICATION

Stainless steel reducers are factory filled with a high quality

STAINLESS STEEL GEARING SOLUTIONS

Sales: 1-888-994-2663
Sales Fax: 1-888-907-2663
Traverse City, MI. 49685

CONEDRIVE.COM

Cone Drive reserves the right to improve or change product design and specifications without notice.

LUBRICATION, INSTALLATION, OPERATION & MAINTENANCE INSTRUCTIONS FOR STAINLESS STEEL CONE DRIVE SPEED REDUCERS

Table 1 Approved Lubricants

These Polyalkylene Glycol based synthetic lubricants are suitable for ambient temperatures of -10°F to 200°F (-23°C to -93°C); outside of this, please contact our Application Engineers.

SUPPLIER	OIL SUPPLIERS CORRESPONDING DESIGNATIONS	ISO VISCOSITY GRADE/ POUR POINT
Kluber Lubrication	Klubersynth Synthetic UH1 6-460	460 (-22°F, -30°C)
Exxon Mobil Corporation	Synthetic Glygoyle 460	460 (-27°F, -33°C)

Table 2 Lubricant Quantities

Applicable for any mounting position:

MOTORIZED or REDUCER		SIZE				
		F039	F044	F050	F060	F076
Oil Capacity	Quarters	0.28	0.32	0.39	0.46	1.04
	Liters	0.26	0.30	0.37	0.44	0.98

Conversion Table

Liters to US gallons = liters x 0.26
Liters to Imperial gallons = liters x 0.22

STORAGE RECOMMENDATIONS FOR CONE DRIVE SPEED REDUCERS

Cone Drive stainless steel speed reducers are fully corrosion resistant with an electro-polished coating which does not require a rust inhibitor. For extended storage periods of up to one year, rotate the worm and gearshaft every 90 days to keep the seals from sticking to the shaft. For storage periods exceeding one year, purchase a spare set of oil seals to have on hand in case of leaking at start-up.

AMBIENT TEMPERATURE

The oils shown in the Approved Lubricants table are for use in an ambient temperature range of approximately -10°F to 200°F with the low end of the range depending on the pour point of the specific oil used.

If the ambient temperature will be below or above this range, please contact Cone Drive for specific recommendations on proper lubricant as well as proper oil seal materials.

Lubrication is very important for successful operation of Cone Drive gearsets and speed reducers. Please review these lubrication recommendations and maintenance guidelines, as inadequate lubrication can result in increased power consumption, added maintenance, and gearset failure. Cone Drive recommends only the listed lubricants as the use of other lubricants can result in gearset failure which will not be covered under warranty and may not conform to food grade standards.

Note



Cone Drive Operations, Inc.

240 East 12th Street
Traverse City, Michigan 49684
USA

Cone Drive Operations, Ltd.

1 Redwood Crescent, Peel Park
East Kilbride G74 5PA
UK

H-Fang

A Cone Drive Company
No. 20 Yungu Road
Changshou
Zhouzhuang Town, Jiangyin
Jiangsu PR China 214424