

# Square

# Gears

Cat.: CT-VFM-Q-HM015

**Worm gearboxes**

Riduttori a vite senza fine  
0.06 ÷ 15 kW

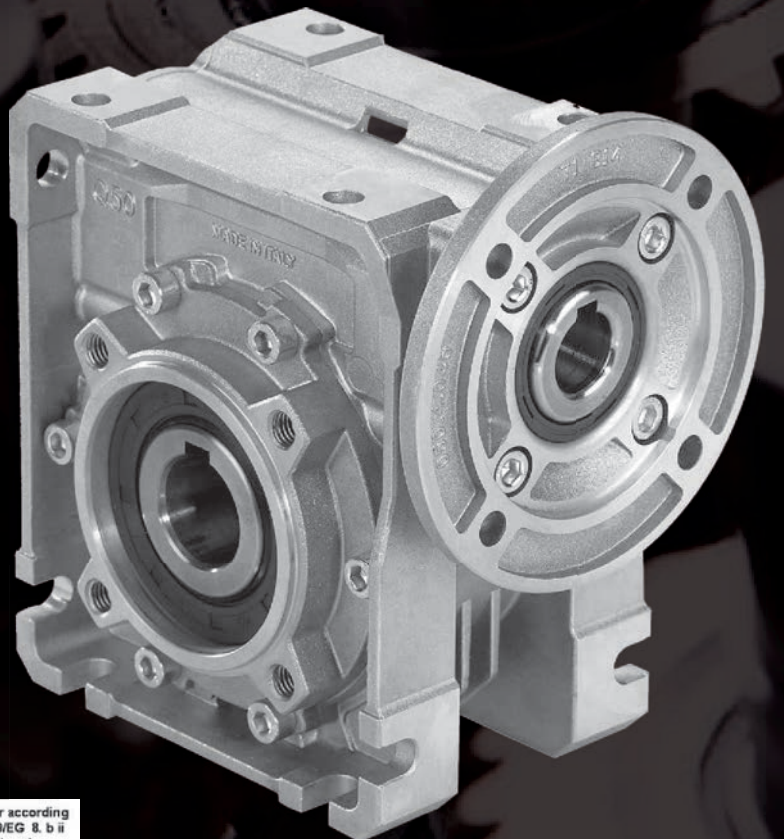
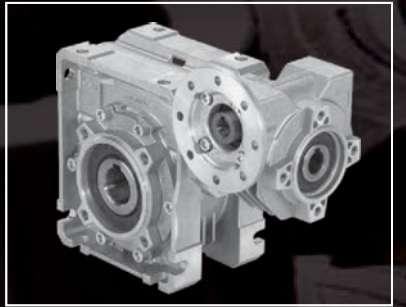
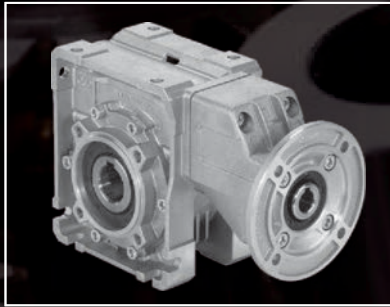
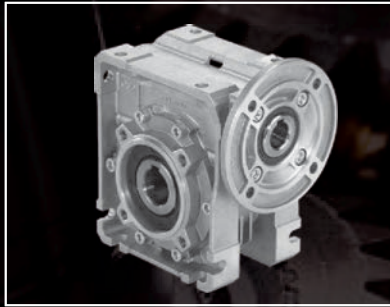

Made in Italy



Dossier according  
to 94/9/EG 8. b ii  
stored



# HYDRO • MEC

# Square worm gearboxes

## A modular and compact product

### Single-piece aluminum alloy housing

Is vacuum impregnated (MIL-STD 276) for protection and sealing.

No secondary finish required but readily accepts paint. Combines light weight with high tensile strength. Precision machined for alignment of bearings and gearing.

### Single piece alloy steel input shaft and worm shaft.

High helix angle worm is case-hardened (Rc 58-60), ground, teeth are profiled and radiused, for noise reduction and enhanced efficiency.

### Oversized bearings

Support positively-retained, high speed shaft for higher shock load capacity - ideal for frequent starting and reversing application. Premium, Nitrile® high temperature seals each end.

### Flange

Fully modular to IEC and compact integrated motor. NEMA C flange.

### Premium, high temperature

Nitrile® output seals

### Bronze alloy worm gears.

Is centrifugally cast onto an iron hub for maximum strength and superior life.

### Oversize bearing

For radial load capability and maximum hollow output shaft diameter.

### Standard hollow output shaft mounting

Reduces total drive envelope size, weight and cost. Single and double solid output shaft is available.

### Impregnated and machined bearing caps

With exterior machined surfaces enable a variety of mounting accessories. Extra-deep thread engagement provided for greater support strength. Zinc plated hardware.

### Vent Free Design.

No breather or vents to leak! Factory lubricated for life with synthetic, semi-fluid gear lubricant with an operating range of -15°C to 130°C.

oil free



vent free



World wide sales network.

# Specific type datasheet on page...

On page / A pagina / Auf Seite / À la page / En la página

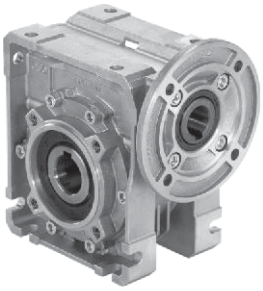

Types / Tipi /  
Tipen / Types /  
Tipos →

2-5	2-7	2-9	2-11	2-13	2-15	2-17	2-19	2-21
<b>Q30</b> 21Nm	<b>Q45</b> 41Nm	<b>Q50</b> 72Nm	<b>Q63</b> 147Nm	<b>Q75</b> 270Nm	<b>Q85</b> 347Nm	<b>Q11</b> 651Nm	<b>Q13</b> 1050Nm	<b>Q15</b> 1550Nm

On page / A pagina / Auf Seite / À la page / En la página

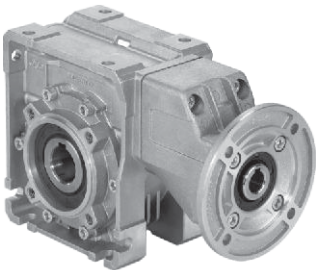

Types / Tipi /  
Tipen / Types /  
Tipos →

2-23	2-25	2-27	2-29	2-31	2-33
<b>P4Q</b> 55Nm	<b>P5Q</b> 88Nm	<b>P6Q</b> 187Nm	<b>P7Q</b> 310Nm	<b>P8Q</b> 440Nm	<b>P1Q</b> 803Nm

On page / A pagina / Auf Seite / À la page / En la página

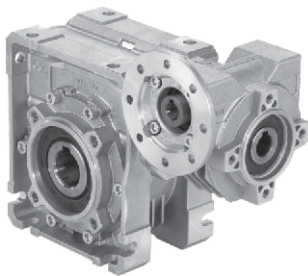

Types / Tipi /  
Tipen / Types /  
Tipos →

2-35	2-37	2-39	2-41	2-43	2-45	2-47
<b>43Q</b> 69Nm	<b>53Q</b> 109Nm	<b>63Q</b> 230Nm	<b>64Q</b> 265Nm	<b>74Q</b> 359Nm	<b>84Q</b> 518Nm	<b>15Q</b> 978Nm

Type - Tipo - Typ  
Type - Tipo

Size - Grandezza  
Größe - Taille  
Tamaño

Mounting - Montaggio - Montage Fixation  
Fixation - Tipo de montaje

**P**

**Q45**

**FC**

**Worm gearboxes**

Riduttori a vite senza fine  
Schneckengetriebe  
Reducteurs a vis sans fin  
Reductores de corona sin fin

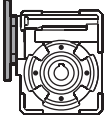

**P**

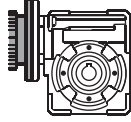

**M**



**B**

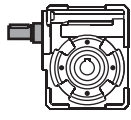

**R**

Q30  
Q45  
Q50  
Q63  
Q75  
Q85  
Q11  
Q13  
Q15

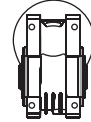

**FB**

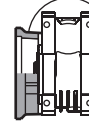

**FC**

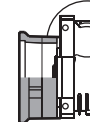

**FL**

F1  
F2  
F3  
F4

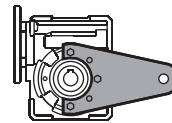

**BR**

**Worm gearboxes with primary reduction**

Riduttori a vite senza fine con precoppia  
Schneckengetriebe mit Stirradstufe am Eintrieb  
Reducteurs a vis sans fin avec pré-réduction  
Reductores corona sin fin con prerreductora de engrajes

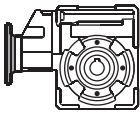

**P**

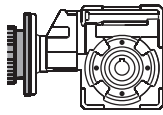

**M**

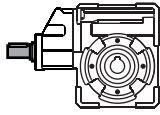

**R**

P4Q  
P5Q  
P6Q  
P7Q  
P8Q  
P1Q



**FB**

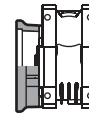

**FC**

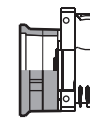

**FL**

F1  
F2  
F3  
F4

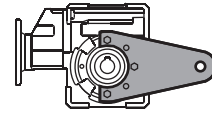

**BR**

**Combined worm gearboxes**

Riduttori a vite senza fine combinati  
Schneckengetriebekombinationen  
Reducteurs a double train de vis sans fin  
Reductores combinados corona sin fin

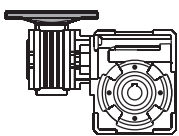

**P**

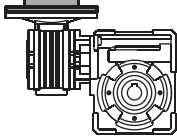

**M**

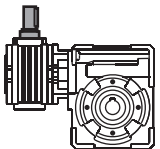

**R**

43Q  
53Q  
63Q  
64Q  
74Q  
84Q  
15Q

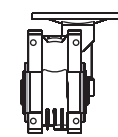

**FB**

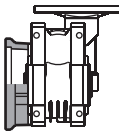

**FC**

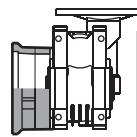

**FL**

F1  
F2  
F3  
F4

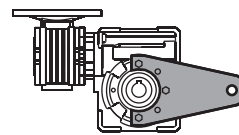



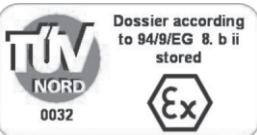



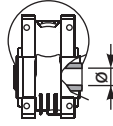
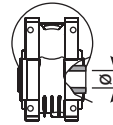
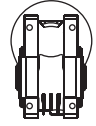
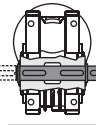
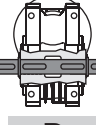
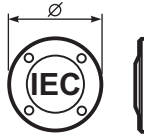

**BR**

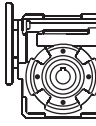

On request we can deliver our products according to the ATEX  
A richiesta possiamo fornire i nostri prodotti secondo le normative ATEX  
Auf Anfrage können wir unsere Produkte den Richtlinien ATEX entsprechend liefern  
Sur demande nos produits peuvent se conformer à la réglementation ATEX  
A pedido, se pueden enviar nuestros productos de acuerdo con las normas ATEX.

CODIFICA / HOW TO ORDER / TYPENBEZEICHNUNGEN / CODIFICATION / CODIFICACIÓN

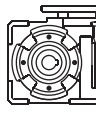
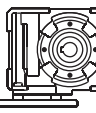
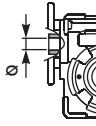
Ratio Rapporto Untersetzung Reduction Relación	Hub Mozzo corona Hohlwelle Arbre creux Nucleo corona	Output shaft Albero lento Abtriebswelle Arbre de sortie Eje solida	Motor size Grandezza motore Motor Grösse Grandeur moteur Tamaño motor	Terminal box position Posizione morsettiere Klemmkastenlage Position boîte a bornes Posición caja de bornes	Mounting position Posizione montaggio Einbaulage Position de montage Position de montaje	Reduced Input bore Foro entrata ridotto Reduzierte Eingangshohlwelle Trou d'entree de diametre reduit Eje hueco de entrada reducido	Mountin position Esecuzione montaggio Einbaulage Exécution de montage Posición de montaje
<b>10</b>	<b>C</b>	<b>∅</b>	<b>-Q</b>	<b>B</b>	<b>B3</b>	<b>-</b>	<b>---</b>
See technical data table Vedi tabella dati tecnici. Technisches Datenblatt beachten Voir tableau données techniques Ver tabla datos técnicos	 <p>STANDARD</p> <p><b>C</b></p> <p>Q30 ⇨ ∅14 Q45 ⇨ ∅18 Q50 ⇨ ∅25 Q63 ⇨ ∅25 Q75 ⇨ ∅30 Q85 ⇨ ∅35 Q11 ⇨ ∅42 Q13 ⇨ ∅45 Q15 ⇨ ∅50</p> <p><b>I</b></p> <p>Stainless steel hub Mozzo in acciaio Inox Edelstahlhohlwelle Moyeu en acier Inox Nucleo corona de acero Inox</p> <p>SPECIAL SERIES: SERIE SPECIALE:</p> <p><b>S</b></p> <p>Q45 ⇨ ∅19 Q50 ⇨ ∅24</p> <p><b>X</b></p> <p>Stainless steel hub Mozzo in acciaio Inox Edelstahlhohlwelle Moyeu en acier Inox Nucleo corona de acero Inox</p>  <p>INCH</p> <p><b>U</b></p> <p>Q45 ⇨ ∅0.750" Q50 ⇨ ∅1.000" Q63 ⇨ ∅1.125" Q85 ⇨ ∅1.500"</p> <p><b>Z</b></p> <p>Stainless steel hub Mozzo in acciaio Inox Edelstahlhohlwelle Moyeu en acier Inox Nucleo corona de acero Inox</p>	 <p><b>∅</b></p>  <p><b>S</b></p>  <p><b>D</b></p>	 <p><b>-M</b> without flange Senza flangia</p> <p><b>B5</b></p> <p><b>-A</b>=56 (∅120)</p> <p><b>-B</b>=63 (∅140)</p> <p><b>-C</b>=71 (∅160)</p> <p><b>-D</b>=80 (∅200)</p> <p><b>-E</b>=90 (∅200)</p> <p><b>-F</b>=100+112 (∅250)</p> <p><b>-G</b>=132 (∅300)</p> <p><b>-H</b>=160 (∅350)</p> <p><b>B14</b></p> <p><b>-O</b>=56 (∅80)</p> <p><b>-P</b>=63 (∅90)</p> <p><b>-Q</b>=71 (∅105)</p> <p><b>-R</b>=80 (∅120)</p> <p><b>-T</b>=90 (∅140)</p> <p><b>-U</b>=100+112 (∅160)</p> <p><b>-V</b>=132 (∅200)</p> <p><b>-0</b>=Type R <b>-S</b>=Type R S series</p>	 <p><b>A</b></p>  <p><b>B</b></p> <p>STANDARD</p>  <p><b>C</b></p>  <p><b>D</b></p>	 <p><b>B3</b></p>  <p><b>B8</b></p>  <p><b>B6</b></p>  <p><b>B7</b></p>  <p><b>V5</b></p>  <p><b>V6</b></p>	 <p><b>-</b></p> <p>Nothing indication standard bore</p> <p>Nessuna indicazione foro standard</p> <p><b>P</b></p> <p>Input bore reduced one size</p> <p>Foro entrata ridotto di una misura</p> <p>Ex. Input Flange 71 B14 Standard ∅14 Reduced ∅11</p> <p><b>Q</b></p> <p>Input bore reduced two sizes</p> <p>Due grandezze ridotte foro entrata</p> <p>Ex. Input Flange 71 B14 Standard ∅14 Reduced ∅9</p>	<p><b>Only for combined units See technical data table</b></p> <p>Solo per i riduttori combinati Vedi tabella dati tecnici.</p> <p>Ausführungen für Getriebekombinationen it</p> <p>Uniquement pour combinés. Voir tableau données techniques</p> <p>Sólo para combinados ver tabla datos técnicos</p>

POTENZA RICHIESTA / REQUIRED POWER / ERFORDERLICHE LEISTUNG / PUISSANCE NECESSAIRE / POTENCIA NECESARIA

Lifting / sollevamento / hubantriebe / levage / elevación

$$P [KW] = \frac{M [Kg] \cdot g [9.81] \cdot v [m / s]}{1000}$$

Rotation / rotazione / drehung / rotation / rotation

$$P [KW] = \frac{M [Nm] \cdot n [rpm]}{9550}$$

Linear movement / traslazione / linearbewegung / translation / translacion

$$P [KW] = \frac{F [N] \cdot v [m / s]}{1000}$$

TORQUE / COPPIA / DREHMOMENT / COUPLE / PAR

$$M [Nm] = \frac{9550 \cdot P[KW]}{n [rpm]}$$

$$M [lb in] = \frac{63030 \cdot P[HP]}{n [rpm]}$$

RADIAL LOADS / CARICHI RADIALI / RADIALE - UND AXIALLASTEN / CHARGES RADIALES / CARGA RADIAL Y AXIAL

- Radial load generated by external transmissions keyed onto input and/or output shafts.
- Forza radiale generata da organi di trasmissione calettati sugli alberi di ingresso e/o uscita.
- Belastungen der Antriebs- bzw. Abtriebswellen durch von aussen eingebrachte Radiallasten.
- Charge radiale générée par la transmissions calés sur les entrées et / ou des arbres de sortie
- Cargas radiales, generada por transmisiones externas, aplicadas sobre los ejes de entrada y/o salida

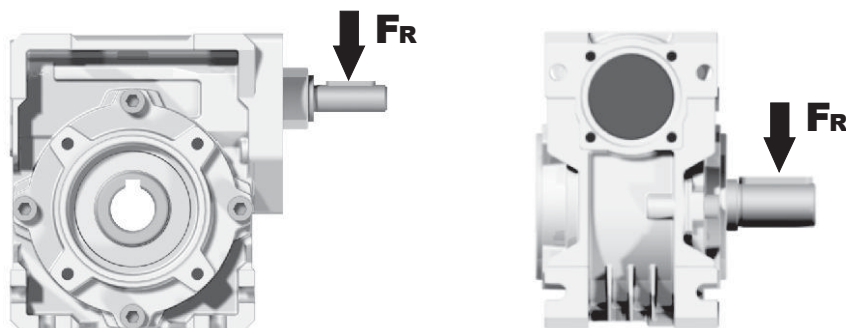

	$F_R [N] = \frac{M [Nm] \cdot 2000}{d [mm]} \cdot f_k$	$F_R [N] = \frac{M [lb in] \cdot 8.9}{d [in]} \cdot f_k$
<b>M</b>	Momento torcente / Output torque / Abtriebsdrehmoment / Couple / Par torsion	
<b>d</b>	Diametro primitivo / Diam. of driving element / Durchmesser der Abtriebseinheit / Diamètre primitif / Diámetro primitivo	
<b>f<sub>k</sub></b>	Coefficiente di trasformazione / Factor / Faktor / Coefficient de transmission / Coeficiente de transmisión <b>1.15</b> Ingranaggi / Gearwheels / Zahnrad / Engrenage / Engranaje <b>1.25</b> Catena / Chain sprockets / Antriebskette / Chaîne / Cadena <b>1.75</b> Cinghia Trapezoidale / Narrow v-belt pulley / Keilriemen / Courroie trap. / Correa trapezoidal <b>2.50</b> Cinghia piatta / Flat-belt pulley / Flachzahnriem. / Courroie crantée / Correa plana	

- If your application requires higher radial loads, contact our technical office. Higher load may be possible.
- Nel caso la vostra applicazione richieda carichi radiali superiori consultare il nostro ufficio tecnico, valori maggiori possono essere accettati.
- Wenn Ihre Anwendung höhere Radialbelastungen erfordert, so wenden Sie sich bitte an unser technischen Büro.
- Si votre application demande des charges radiales supérieures, s'adresser à notre bureau technique.
- En el caso en que una aplicación exija una carga radial superior a la especificada en el catálogo, consultar a nuestra oficinas técnica.

How to select a gearbox / Come selezionare un riduttore / Wie wählt man ein Getriebe  
Comment sélectionner un réducteur / Cómo seleccionar un reductor

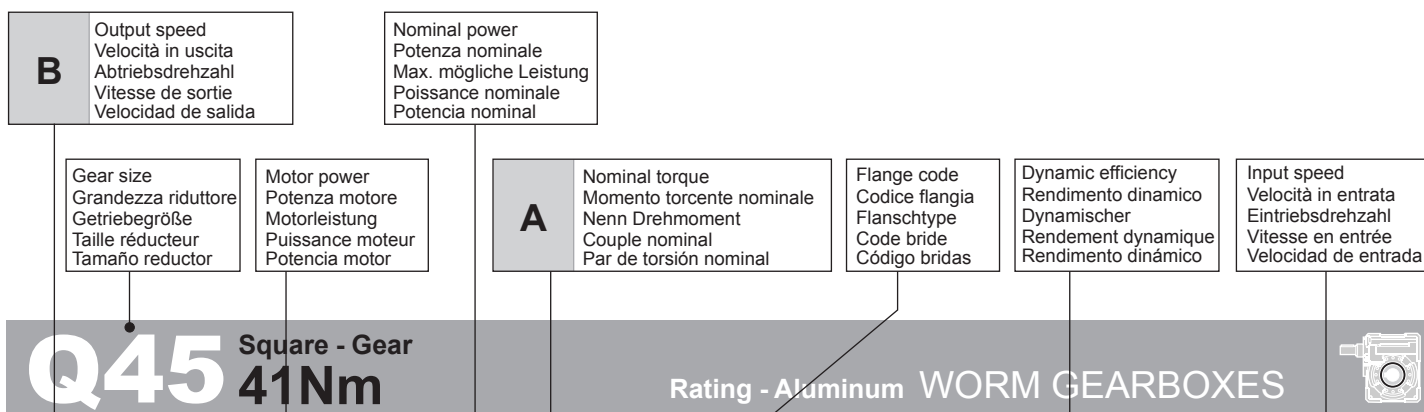

QUICK SELECTION / Selezione veloce

Output Speed $n_2$ [min <sup>-1</sup> ]	Ratio i	Motor power $P_{1M}$ [kW]	Output torque $M_{2M}$ [Nm]	Service factor f.s.	Nominal power $P_{1R}$ [kW]	Nominal torque $M_{2R}$ [Nm]	Available B5 motor flanges		Available B14 motor flanges			Dynamic efficiency RD	Tooth Module [mm]	Ratios code
							-B	C	-O	-P	-Q			
200	7	0.37	14	2.2	0.80	30	B		B-C	B-C		80	2.2	01
140	10	0.37	20	1.5	0.57	30	B		B-C	B-C		79	2.2	02
100	14	0.37	27	1.1	0.41	30	B		B-C	B-C		77	2.4	03

**C** Ratio  
Rapporto  
Untersetzung  
Rapport de réduction  
Relación

Transmitted torque  
Momento torcente trasmesso  
Mögliche Drehmomente  
Couple de sortie  
Par transmitido

Service factor  
Fattore di servizio  
Betriebsfaktor  
Facteur de service  
Factor de servicio

Nominal module  
Modulo nominale  
Nenn modul  
Module nominale  
Módulo nominal

Notes  
Note  
Anmerkungen  
Note  
Notas

Type of load and starts per hour Tipo di carico e avviamenti per ora		Oper. hours per day Ore di funz. giorn.		
		<2 h	2 - 8 h	8 - 16 h
Continuous or intermittent appl. with start / hour Applicazione cont. o interm. con n.ro operazioni/ora	Uniform / Uniforme	0.9	1	1.25
	Moderate / Moderato	1	1.25	1.5
	Heavy / Forte	1.25	1.5	1.75
Intermittent application with start / hour Applicazione intermittente con n.ro operazioni/ora	Uniform / Uniforme	1.25	1.5	1.75
	Moderate / Moderato	1.5	1.75	2
	Heavy / Forte	1.75	2	2.25

<b>D</b>	Motor flange available Flange disponibili Erhältliche Motorflansche Brides disponibles Bridas disponibles	
<b>B)</b>	Mounting with reduction ring Montaggio con boccia di riduzione Reduzierhülsen Montage avec douille de réduction Montaje con casquillo de reducción	
<b>C)</b>	Motor flangeholes position/terminal box position Posizione fori flangia/basetta motore Bohrungsposition am Motorflansch/-socket Position trous bride/barrette à bornes moteur Posición agujeros brida / base motor	
<b>B)</b>	Available without reduction bushes Disponibile anche senza boccia Auch ohne Reduzierbuchse verfügbar Disponible aussi sans douille de réduction Disponible también sin casquillo	

<b>A</b>	Select required torque (according to service factor)	Seleziona la coppia desiderata (comprensiva del fattore di servizio)	Max. Drehmoment in Bezug zum Betriebsfaktor	Sélectionner le couple souhaité (comprenant le facteur de service)	Seleccionar el par deseado (incluyendo el factor de servicio)
<b>B</b>	Select output speed	Seleziona la velocità in uscita	Ausgewählte Abtriebsdrehzahl	Sélectionner la vitesse de sortie	Seleccionar la velocidad de salida
<b>C</b>	On the same line of selected geared motor, you can find the gear ratio	Sulla riga corrispondente alla motorizzazione prescelta si può rilevare il rapporto di riduzione	Auf der gleichen Linie wie die ausgewählte Motorleistung steht auch die Getriebeuntersetzung	Sur la ligne correspondante à la motorisation pré-choisie on peut relever le rapport de réduction	En la línea correspondiente al motor preseleccionado es posible encontrar la relación de reducción
<b>D</b>	Select motor flange available (if requested)	Scegli la flangia disponibile (se richiesta)	Erhältliche Motorflansche (auf Anfrage)	Choisir la bride disponible (si elle est demandée)	Seleccionar la brida disponible (sobre pedido)



### QUICK SELECTION / Selezione veloce

input speed ( $n_1$ ) = 1400 min<sup>-1</sup>

Output Speed $n_2$ [min <sup>-1</sup> ]	Ratio $i$	Motor power $P_{1M}$ [kW]	Output torque $M_{2M}$ [Nm]	Service factor f.s.	Nominal power $P_{1R}$ [kW]	Nominal torque $M_{2R}$ [Nm]	Available B5 motor flanges		Available B14 motor flanges		Dynamic efficiency <b>RD</b>	Tooth Module  [mm]	 Ratios code
							-A	-B	-O	-P			
							56	63	56	63			
280	<b>5</b>	0.18	5	3.3	<b>0.60</b>	17	B		B-C		82	1.26	01
200	<b>7</b>	0.18	7	2.4	<b>0.44</b>	17	B		B-C		80	1.44	02
140	<b>10</b>	0.18	10	1.8	<b>0.32</b>	17	B		B-C		78	1.44	03
93	<b>15</b>	0.18	13	1.4	<b>0.25</b>	19	B		B-C		73	1.44	04
70	<b>20</b>	0.18	17	1.1	<b>0.20</b>	19	B		B-C		70	1.09	05
47	<b>30</b>	0.12	15	1.4	<b>0.17</b>	21	B		B-C		62	1.44	06
35	<b>40</b>	0.12	19	1.1	<b>0.13</b>	20	B		B-C		57	1.09	07
23	<b>61</b>	0.09	19	1.1	<b>0.10</b>	20	B		B-C		50	0.72	08
17.5	<b>80</b>	0.09	16	1.0	<b>0.06</b>	16	B		B-C		48	0.56	09

**A) Motor Flanges Available**  
Flange Motore Disponibili

**B) Supplied with Reduction Bushing**  
Fornito con Bussola di Riduzione

**B) Available on Request without reduction bushing**  
Disponibile a Richiesta senza Bussola di Riduzione

**C) Motor Flange Holes Position**  
Posizione Fori Flangia Motore

**EN** Unit Q30 is supplied with synthetic oil, providing "long life" lubrication. For mounting position V5-V6 please contact us. See table 1 for lubrication and recommended quantity. In table 2 please see possible radial loads and axial loads on the gearbox.

**I** Il riduttore tipo Q30 viene fornito lubrificato a vita con olio sintetico. Per posizioni V5-V6 contattare il ns. servizio tecnico. Vedi tab.1 per oli e quantità consigliati. In tab.2 sono presenti i carichi radiali e assiali applicabili al riduttore.

**D** Für die Lebensdauerschmierung ist das Getriebe der Größe Q30 mit synthetischem Öl befüllt. Bei Einbaulage V5 oder V6 bitten wir um Rücksprache. In Tabelle 1 ist die Schmiermenge und das empfohlene Schmiermittel angegeben. In Tabelle 2 sind die zulässigen Radial- und Axialbelastungen des Getriebes aufgeführt.

**F** Le réducteur de type Q30 est fourni lubrifié à vie avec de l'huile synthétique. Concernant les positions V5.V6, contactez notre service d'assistance technique. Voir tableau 1 concernant les huiles et les quantités conseillées. Les charges radiales et axiales applicables au réducteur sont précisées dans le tableau 2.

**E** El reductor tamaño Q30 se suministra, lubricado de por vida con aceite sintético. Para las posiciones V5 y V6 contactar con nuestro servicio técnico. Ver tabla 1, para cantidades y aceites recomendados. En la tabla 2, se encuentran las cargas radiales y axiales admitidas por el reductor.

### LUBRICATION Q30 Oil Quantity 0.03Lt.

**AGIP** Telium VSF 320

**SHELL** Omala S4 WE 320

For all details on lubrication and plugs check our website **tab. 1**  
Per maggiori dettagli su lubrificazione e tappi olio vedi il nostro sito web

### RADIAL AND AXIAL LOADS

#### Output shaft

Albero di uscita

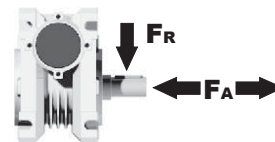

$n_2$ [min <sup>-1</sup> ]	FA [N]	FR [N]
200	120	600
150	140	700
100	160	800
75	180	900
50	200	1000
25	250	1250
15	280	1400

#### Input shaft

albero in entrata

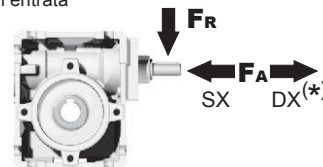

$n_1$ [min <sup>-1</sup> ]	FA [N]	FR [N]
1400	20	100

**\*Strong axial loads in the DX direction are not allowed.**  
Non sono consentiti forti carichi assiali con direzione DX

tab. 2



PQ30**FB**... Basic wormbox  
Riduttore base

Gearbox weight  
peso riduttore **1.15 kg**

M. flanges	Kit code	øF	A
<b>56B5</b>	K030.4.041	120	61.5
<b>63B5</b>	K030.4.042	140	62.5
<b>56B14</b>	K030.4.046	80	61.5
<b>63B14</b>	K030.4.045	90	62.5

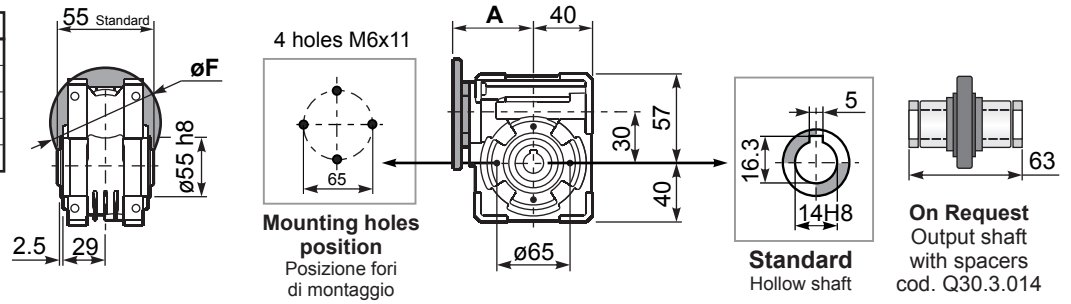

PQ30**FC**... Square flange  
Flangia quadrata

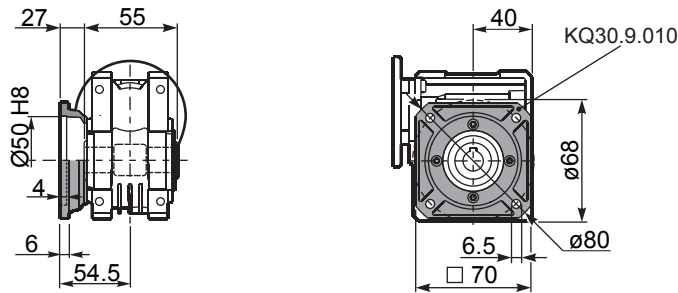

PQ30**FB**... Feet  
Piedini

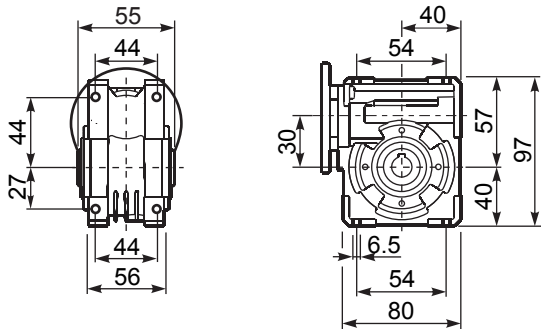

PQ30**BR**... Reaction arm  
Braccio di reazione

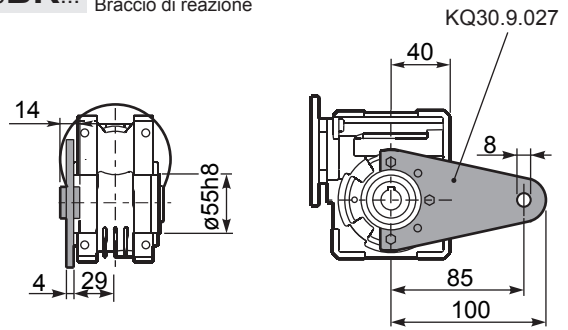

RQ30**FB**... Input shaft  
Albero in entrata

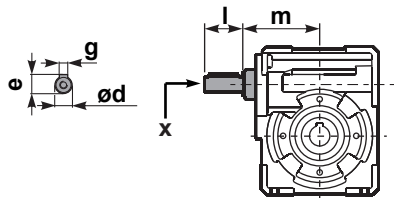

PQ30.....**S**... Single Shaft  
Albero lento semplice

PQ30.....**D**... Double Shaft  
Albero lento bisp.

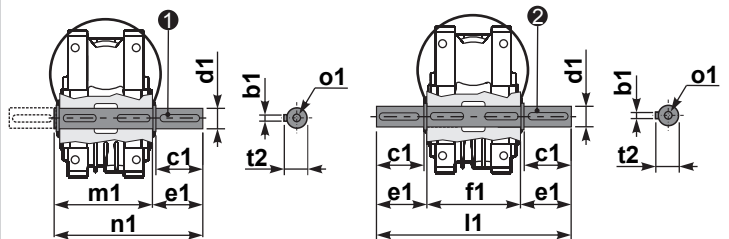

① kit cod. K030.5.028 type B

② kit cod. K030.5.029 type B

	ød	e	g	l	m	x	kit code
type B	9 h6	10.2	3	20	58	-	K030.5.006 PAM63
type S	-	-	-	-	-	-	-

	b1	c1	d1	e1	f1	l1	m1	n1	t2	o1
type B	5	25	14 <sup>-0.005</sup> <sub>-0.020</sub>	35.5	55	126	59	94.5	16	M5x14
type S	-	-	-	-	-	-	-	-	-	-



#### QUICK SELECTION / Selezione veloce

input speed ( $n_1$ ) = 1400 min<sup>-1</sup>

Output Speed $n_2$ [min <sup>-1</sup> ]	Ratio $i$	Motor power $P_{1M}$ [kW]	Output torque $M_{2M}$ [Nm]	Service factor f.s.	Nominal power $P_{1R}$ [kW]	Nominal torque $M_{2R}$ [Nm]	Available B5 motor flanges		Available B14 motor flanges			Dynamic efficiency RD	Tooth Module [mm]	Ratios code
							-B	-C	-O	-P	-Q			
							63	71	56	63	71			
200	7	0.37	14	2.2	0.80	30	B		B-C	B-C		80	2.2	01
140	10	0.37	20	1.5	0.57	30	B		B-C	B-C		79	2.2	02
100	14	0.37	27	1.1	0.41	30	B		B-C	B-C		77	2.4	03
67	21	0.37	36	1.2	0.43	41	B		B-C	B-C		67	1.6	04
50	28	0.25	31	1.3	0.33	41	B		B-C	B-C		65	2.5	05
38	37	0.25	40	1.0	0.26	41	B		B-C	B-C		63	1.8	06
30	46	0.25	46	0.9	0.22	41	B		B-C	B-C		59	1.5	07
23	60	0.18	41	1.0	0.18	41	B		B-C	B-C		56	1.2	08
20	70	0.12	31	1.0	0.12	30	B		B-C	B-C		54	1.0	09
13.7	102	0.09	31	1.0	0.09	29	B		B-C	B-C		49	0.72	10

**A** Motor Flanges Available  
Flange Motore Disponibili

**B** Supplied with Reduction Bushing  
Fornito con Bussola di Riduzione

**B** Available on Request without reduction bushing  
Disponibile a Richiesta senza Bussola di Riduzione

**C** Motor Flange Holes Position  
Posizione Fori Flangia Motore

\* Power higher than the maximum one which can be supported by the gearbox. Select according to the torque  $M_{2R}$   
Potenza superiore a quella massima sopportabile dal riduttore. Selezionare in base al momento torcente  $M_{2R}$

**EN** Unit Q45 is supplied with synthetic oil, providing "long life" lubrication. For mounting position V5-V6 please contact us. See table 1 for lubrication and recommended quantity. In table 2 please see possible radial loads and axial loads on the gearbox.

**I** Il riduttore tipo Q45 viene fornito lubrificato a vita con olio sintetico. Per posizioni V5-V6 contattare il ns. servizio tecnico. Vedi tab.1 per oli e quantità consigliati. In tab.2 sono presenti i carichi radiali e assiali applicabili al riduttore.

**D** Für die Lebensdauerschmierung ist das Getriebe der Größe Q45 mit synthetischem Öl befüllt. Bei Einbaulage V5 oder V6 bitten wir um Rücksprache. In Tabelle 1 ist die Schmiermenge und das empfohlene Schmiermittel angegeben. In Tabelle 2 sind die zulässigen Radial- und Axialbelastungen des Getriebes aufgeführt.

**F** Le réducteur de type Q45 est fourni lubrifié à vie avec de l'huile synthétique. Concernant les positions V5.V6, contactez notre service d'assistance technique. Voir tableau 1 concernant les huiles et les quantités conseillées. Les charges radiales et axiales applicables au réducteur sont précisées dans le tableau 2.

**E** El reductor tamaño Q45 se suministra, lubricado de por vida con aceite sintético. Para las posiciones V5 y V6 contactar con nuestro servicio técnico. Ver tabla 1, para cantidades y aceites recomendados. En la tabla 2, se encuentran las cargas radiales y axiales admitidas por el reductor.

#### LUBRICATION Q45 Oil Quantity 0.09 Lt.

AGIP Telium VSF 320

SHELL Omala S4 WE 320

For all details on lubrication and plugs check our website **tab. 1**  
Per maggiori dettagli su lubrificazione e tappi olio vedi il nostro sito web

#### RADIAL AND AXIAL LOADS

**Output shaft**  
Albero di uscita

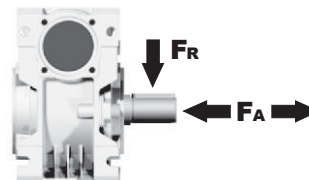

$n_2$ [min <sup>-1</sup> ]	FA [N]	FR [N]
200	180	900
150	200	1000
100	220	1100
75	240	1200
50	260	1400
25	300	1800
15	400	2000

**Input shaft**  
albero in entrata

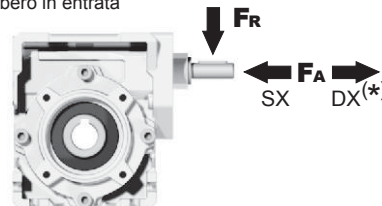

$n_1$ [min <sup>-1</sup> ]	FA [N]	FR [N]
1400	42	210

\*Strong axial loads in the DX direction are not allowed.  
Non sono consentiti forti carichi assiali con direzione DX

tab. 2

**PQ45FB...** Basic wormbox  
Riduttore base

M. flanges	Kit code	øF	A
<b>63B5</b>	K050.4.041	138	80
<b>71B5</b>	K050.4.042	160	77.5
<b>56B14</b>	KC40.4.049	80	77.5
<b>63B14</b>	K050.4.047	90	80
<b>71B14</b>	K050.4.045	105	77.5

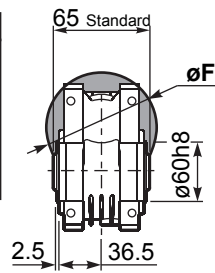

4 holes M6x12  
Mounting holes position  
Posizione fori di montaggio

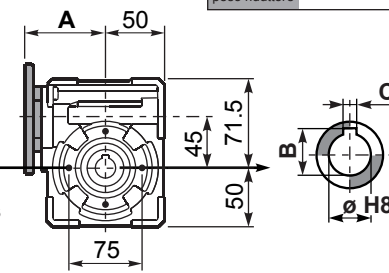

Gearbox weight  
peso riduttore **2.30 kg**

ø H8	B	C	*Spacer code
<b>18</b> Standard	20.8	6	Q45.3.018
<b>19</b> on request	21.8	6	Q45.3.019
<b>20</b> on request	22.8	6	Q45.3.020

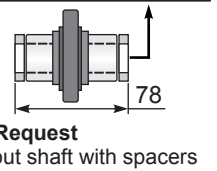

\*On Request  
output shaft with spacers

**PQ45FC...** Square flange  
Flangia quadrata

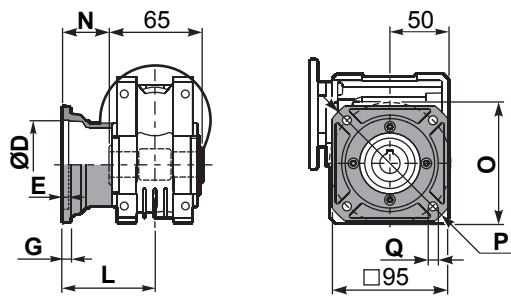

type B	øD	E	G	L	N	O	P	Q	kit code
<b>FC</b>	60 H8	4	7	67	34.5	75	110	9	KQ45.9.010
<b>FL</b>	60 H8	4	7	97	64.5	75	110	9	KQ45.9.011

**PQ45F1...** Round flange  
Flangia rotonda

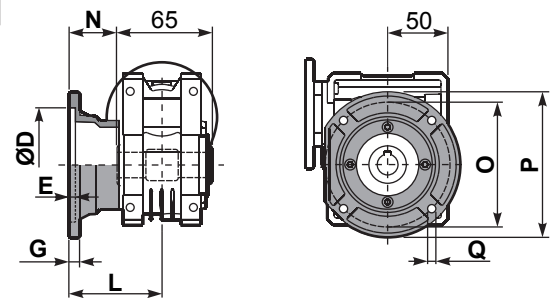

type S	øD	E	G	L	N	O	P	Q	kit code
<b>F1</b>	95H8	5	9	80	47.5	115	140	9.5	KSQ45.9.012
<b>F2</b>	80H8	5	12	58	25.5	100	120	9	KSQ45.9.013

**PQ45FB...** Feet  
Piedini

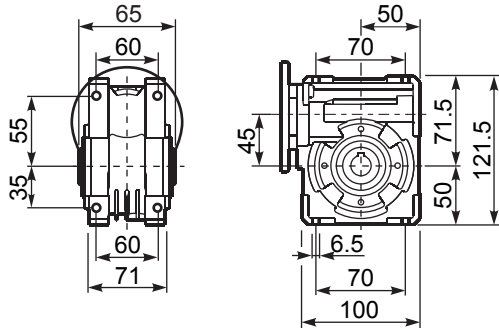

**PQ45BR...** Reaction arm  
Braccio di reazione

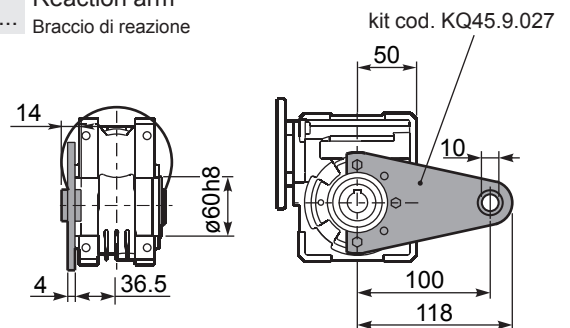

**RQ45FB...** Input shaft  
Albero in entrata

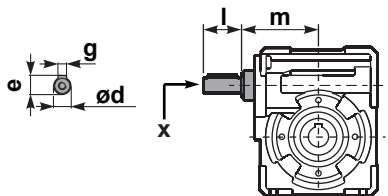

	ød	e	g	l	m	x	kit code
type B	11 h6	12.5	4	30	74	-	① K045.5.006 PAM71 ② - ③ -
type S	-	-	-	-	-	-	① - ② - ③ -

**PQ45.....S...** Single Shaft  
Albero lento semplice

**PQ45.....D...** Double Shaft  
Albero lento bisp.

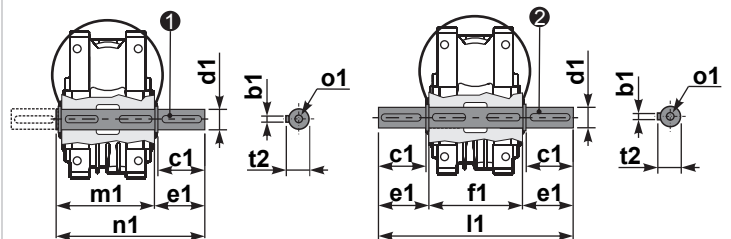

① kit cod. K045.5.028 type B  
kit cod. KS045.5.030 type S  
② kit cod. K045.5.029 type B  
kit cod. KS045.5.031 type S

	b1	c1	d1	e1	f1	l1	m1	n1	t2	o1
type B	6	32	18 <sup>-0.005</sup> <sub>-0.020</sub>	43	65	151	70	113	20.5	M6x18
type S	6	40	19 <sup>-0.005</sup> <sub>-0.020</sub>	58.5	65	182	70	128.5	21.5	M8x20



#### QUICK SELECTION / Selezione veloce

input speed ( $n_1$ ) = 1400 min<sup>-1</sup>

Output Speed $n_2$ [min <sup>-1</sup> ]	Ratio $i$	Motor power $P_{1M}$ [kW]	Output torque $M_{2M}$ [Nm]	Service factor f.s.	Nominal power $P_{1R}$ [kW]	Nominal torque $M_{2R}$ [Nm]	Available B5 motor flanges			Available B14 motor flanges				Dynamic efficiency <b>RD</b>	Tooth Module  [mm]	Ratios code 
							-B	-C	-D	-O	-P	-Q	-R			
							63	71	80	56	63	71	80			
200	7	0.75	29	1.9	1.5	57	B	B			B-C	B		82	2.5	01
140	10	0.75	41	1.5	1.1	62	B	B			B-C	B		80	2.4	02
100	14	0.75	57	1.2	0.90	68	B	B			B-C	B		79	2.6	03
78	18	0.55	51	1.2	0.67	62	B	B			B-C	B		75	2.0	04
54	26	0.55	67	1.0	0.54	66	B	B			B-C	B		69	2.7	05
47	30	0.55	79	0.9	0.50	72	B	B			B-C	B		70	2.5	12
39	36	0.37	63	1.2	0.43	72	B			B-C	B-C		69	2.1	06	
33	43	0.37	72	1.0	0.35	68	B			B-C	B-C		66	1.8	07	
23	60	0.25	59	1.0	0.26	62	B			B-C	B-C		58	1.3	08	
21	68	0.25	66	0.9	0.22	58	B			B-C	B-C		57	1.2	09	
17.5	80	0.18	53	1.1	0.19	57	B			B-C	B-C		54	1.0	10	
14	100	0.12	41	1.3	0.15	51	B			B-C	B-C		50	0.8	11	

**A) Motor Flanges Available**  
Flange Motore Disponibili

**B) Supplied with Reduction Bushing**  
Fornito con Bussola di Riduzione

**B) Available on Request without reduction bushing**  
Disponibile a Richiesta senza Bussola di Riduzione

**C) Motor Flange Holes Position**  
Posizione Fori Flangia Motore

**EN** Unit **Q50** is supplied with synthetic oil, providing "long life" lubrication. For mounting position V5-V6 please contact us. See table 1 for lubrication and recommended quantity. In table 2 please see possible radial loads and axial loads on the gearbox.

**I** Il riduttore tipo **Q50** viene fornito lubrificato a vita con olio sintetico. Per posizioni V5-V6 contattare il ns. servizio tecnico. Vedi tab.1 per oli e quantità consigliati. In tab.2 sono presenti i carichi radiali e assiali applicabili al riduttore.

**D** Für die Lebensdauerschmierung ist das Getriebe der Größe **Q50** mit synthetischem Öl befüllt. Bei Einbaulage V5 oder V6 bitten wir um Rücksprache. In Tabelle 1 ist die Schmiermenge und das empfohlene Schmiermittel angegeben. In Tabelle 2 sind die zulässigen Radial - und Axialbelastungen des Getriebes aufgeführt.

**F** Le réducteur de type **Q50** est fourni lubrifié à vie avec de l'huile synthétique. Concernant les positions V5.V6, contactez notre service d'assistance technique. Voir tableau 1 concernant les huiles et les quantités conseillées. Les charges radiales et axiales applicables au réducteur sont précisées dans le tableau 2.

**E** El reductor tamaño **Q50** se suministra, lubricado de por vida con aceite sintético. Para las posiciones V5 y V6 contactar con nuestro servicio técnico. Ver tabla 1, para cantidades y aceites recomendados. En la tabla 2, se encuentran las cargas radiales y axiales admitidas por el reductor.

#### LUBRICATION Q50 Oil Quantity 0.14 Lt.

**AGIP** Telium VSF 320

**SHELL** Omala S4 WE 320

For all details on lubrication and plugs check our website **tab. 1**  
Per maggiori dettagli su lubrificazione e tappi olio vedi il nostro sito web

#### RADIAL AND AXIAL LOADS

##### Output shaft

Albero di uscita

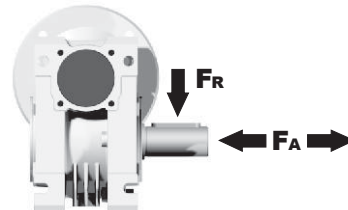

$n_2$ [min <sup>-1</sup> ]	FA [N]	FR [N]
200	240	1200
150	280	1400
100	300	1500
75	340	1700
50	380	1900
25	480	2500
15	560	2800

##### Input shaft

albero in entrata

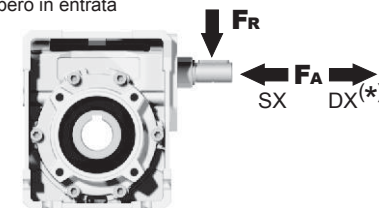

$n_1$ [min <sup>-1</sup> ]	FA [N]	FR [N]
1400	76	380

**\*Strong axial loads in the DX direction are not allowed.**  
Non sono consentiti forti carichi assiali con direzione DX

tab. 2

**PQ50FB...** Basic wormbox  
Riduttore base

Gearbox weight  
peso riduttore **3.25 kg**

ø H8	B	C	*Spacer code
25 Standard	28.3	8	Q50.3.025
24 on request	27.3	8	Q50.3.024

M. flanges	Kit code	øF	A
<b>63B5</b>	K050.4.041	138	83.5
<b>71B5</b>	K050.4.042	160	81
<b>80B5</b>	K050.4.043	200	81.5
<b>56B14</b>	KC40.4.049	80	81
<b>63B14</b>	K050.4.047	90	83.5
<b>71B14</b>	K050.4.045	105	81
<b>80B14</b>	K050.4.046	120	81.5

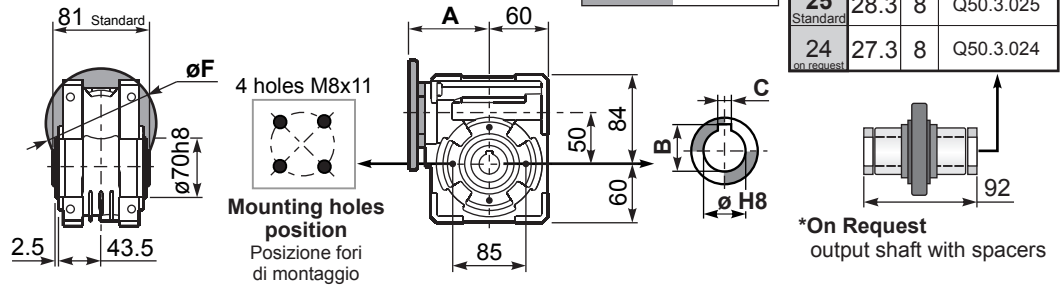

**PQ50FC...** Square flange  
Flangia quadrata

**PQ50F1...** Round flange  
Flangia rotonda

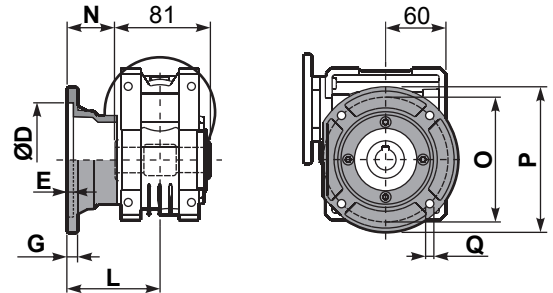
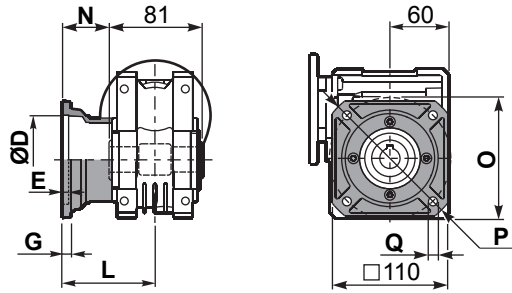

type B	øD	E	G	L	N	O	P	Q	kit code
<b>FC</b>	70 H8	5	9	90	49.5	85	125	11	KQ50.9.010
<b>FL</b>	70 H8	5	9	120	79.5	85	125	11	KQ50.9.011

type S	øD	E	G	L	N	O	P	Q	kit code
<b>F1</b>	110 H8	5	10	89	48.5	130	160	9.5	KSQ50.9.012
<b>F2</b>	95 H8	5	14.5	72	31.5	115	140	11	KSQ50.9.013

**PQ50FB...** Feet  
Piedini

**PQ50BR...** Reaction arm  
Braccio di reazione

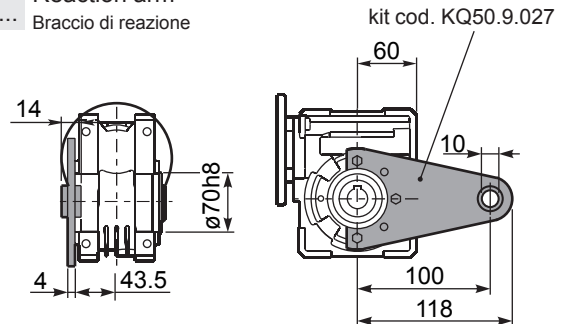
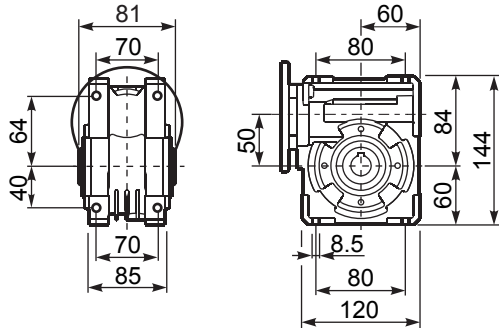

**RQ50FB...** Input shaft  
Albero in entrata

**PQ50.....S...** Single Shaft  
Albero lento semplice

**PQ50.....D...** Double Shaft  
Albero lento bisp.

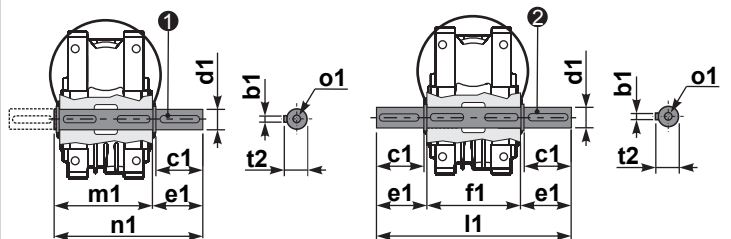
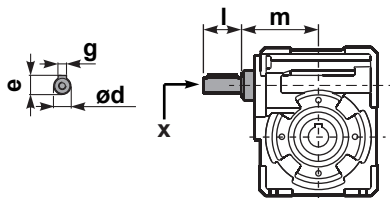

① kit cod. K050.5.028 type B  
kit cod. KS050.5.030 type S

② kit cod. K050.5.029 type B  
kit cod. KS050.5.031 type S

	ød	e	g	l	m	x	kit code
type B	16 h6	18	5	30	79.5	M6x16	① K050.5.006 PAM71 ② K050.5.007 PAM80
type S	14 h6	16	5	30	79.5	M5x10	① KS050.5.008 PAM71 ② KS050.5.009 PAM80

	b1	c1	d1	e1	f1	l1	m1	n1	t2	o1
type B	8	52	25 <sup>-0.005</sup> <sub>-0.020</sub>	59.5	81	200	86.5	146	28	M8x20
type S	8	50	24 <sup>-0.005</sup> <sub>-0.020</sub>	68.8	81	218	86.5	155	27	M8x20



#### QUICK SELECTION / Selezione veloce

input speed ( $n_1$ ) = 1400 min<sup>-1</sup>

Output Speed $n_2$ [min <sup>-1</sup> ]	Ratio $i$	Motor power $P_{1M}$ [kW]	Output torque $M_{2M}$ [Nm]	Service factor f.s.	Nominal power $P_{1R}$ [kW]	Nominal torque $M_{2R}$ [Nm]	Available B5 motor flanges				Available B14 motor flanges			Dynamic efficiency <b>RD</b>	Tooth Module  [mm]	Ratios code 	
							-B	-C	-D	-E	-Q	-R	-T				
							63	71	80	90	71	80	90				
200	<b>7</b>	1.8	71	1.8	<b>3.2</b>	<b>125</b>		<b>B</b>	<b>B</b>			<b>B-C</b>	<b>B-C</b>		83	3.1	01
140	<b>10</b>	1.8	99	1.4	<b>2.4</b>	<b>134</b>		<b>B</b>	<b>B</b>			<b>B-C</b>	<b>B-C</b>		81	3.1	02
93	<b>15</b>	1.5	121	1.1	<b>1.7</b>	<b>138</b>		<b>B</b>	<b>B</b>			<b>B-C</b>	<b>B-C</b>		79	3.1	03
74	<b>19</b>	1.1	111	1.2	<b>1.4</b>	<b>138</b>		<b>B</b>	<b>B</b>			<b>B-C</b>	<b>B-C</b>		78	2.6	04
58	<b>24</b>	1.1	135	1.0	<b>1.2</b>	<b>142</b>		<b>B</b>	<b>B</b>			<b>B-C</b>	<b>B-C</b>		75	2.0	05
47	<b>30</b>	1.1	167	0.9	<b>0.96</b>	<b>146</b>		<b>B</b>	<b>B</b>			<b>B-C</b>	<b>B-C</b>		74	3.2	06
39	<b>36</b>	0.75	125	1.2	<b>0.88</b>	<b>147</b>		<b>B</b>	<b>B</b>			<b>B-C</b>	<b>B-C</b>		68	2.7	07
31	<b>45</b>	0.55	111	1.2	<b>0.67</b>	<b>135</b>	<b>B</b>	<b>B</b>				<b>B-C</b>	<b>C</b>		66	2.1	08
23	<b>60</b>	0.55	140	0.9	<b>0.51</b>	<b>130</b>	<b>B</b>	<b>B</b>				<b>B-C</b>	<b>C</b>		62	1.6	12
21	<b>67</b>	0.55	151	0.8	<b>0.45</b>	<b>124</b>	<b>B</b>	<b>B</b>				<b>B-C</b>	<b>C</b>		60	1.5	09
17.5	<b>80</b>	0.37	115	1.0	<b>0.38</b>	<b>119</b>	<b>B</b>	<b>B</b>				<b>B-C</b>	<b>C</b>		57	1.3	10
14.9	<b>94</b>	0.37	123	1.0	<b>0.36</b>	<b>119</b>	<b>B</b>	<b>B</b>				<b>B-C</b>	<b>C</b>		52	1.1	11

**A** Motor Flanges Available  
Flange Motore Disponibili

**B** Supplied with Reduction Bushing  
Fornito con Bussola di Riduzione

**B** Available on Request without reduction bushing  
Disponibile a Richiesta senza Bussola di Riduzione

**C** Motor Flange Holes Position  
Posizione Fori Flangia Motore

**EN** Unit **Q63** is supplied with synthetic oil, providing "long life" lubrication. For mounting position V5-V6 please contact us. See table 1 for lubrication and recommended quantity. In table 2 please see possible radial loads and axial loads on the gearbox.

**I** Il riduttore tipo **Q63** viene fornito lubrificato a vita con olio sintetico. Per posizioni V5-V6 contattare il ns. servizio tecnico. Vedi tab.1 per oli e quantità consigliati. In tab.2 sono presenti i carichi radiali e assiali applicabili al riduttore.

**D** Für die Lebensdauerschmierung ist das Getriebe der Größe **Q63** mit synthetischem Öl befüllt. Bei Einbaulage V5 oder V6 bitten wir um Rücksprache. In Tabelle 1 ist die Schmiermenge und das empfohlene Schmiermittel angegeben. In Tabelle 2 sind die zulässigen Radial- und Axialbelastungen des Getriebes aufgeführt.

**F** Le réducteur de type **Q63** est fourni lubrifié à vie avec de l'huile synthétique. Concernant les positions V5.V6, contactez notre service d'assistance technique. Voir tableau 1 concernant les huiles et les quantités conseillées. Les charges radiales et axiales applicables au réducteur sont précisées dans le tableau 2.

**E** El reductor tamaño **Q63** se suministra, lubricado de por vida con aceite sintético. Para las posiciones V5 y V6 contactar con nuestro servicio técnico. Ver tabla 1, para cantidades y aceites recomendados. En la tabla 2, se encuentran las cargas radiales y axiales admitidas por el reductor.

#### LUBRICATION Q63 Oil Quantity 0.30 Lt.

**AGIP** Telium VSF 320

**SHELL** Omala S4 WE 320

For all details on lubrication and plugs check our website **tab. 1**  
Per maggiori dettagli su lubrificazione e tappi olio vedi il nostro sito web

#### RADIAL AND AXIAL LOADS

##### Output shaft

Albero di uscita

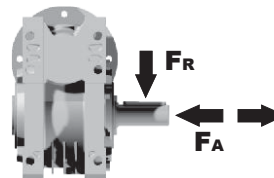

$n_2$ [min <sup>-1</sup> ]	FA [N]	FR [N]
<b>200</b>	360	1800
<b>150</b>	400	2000
<b>100</b>	460	2300
<b>75</b>	500	2500
<b>50</b>	600	3000
<b>25</b>	700	3800
<b>15</b>	800	4000

##### Input shaft

albero in entrata

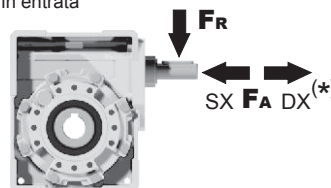

$n_1$ [min <sup>-1</sup> ]	FA [N]	FR [N]
<b>1400</b>	90	450

**\*Strong axial loads in the DX direction are not allowed.**  
Non sono consentiti forti carichi assiali con direzione DX

tab. 2

**PQ63FB...** Basic wormbox  
Riduttore base

Gearbox weight  
peso riduttore **6.00 kg**

M. flanges	Kit code	øF	A
63B5	K063.4.041	140	99.5
71B5	K063.4.042	160	97.5
80/90B5	K063.4.043	200	99.5
71B14	K063.4.047	105	97.5
80B14	K063.4.046	120	99.5
90B14	K063.4.041	140	99.5

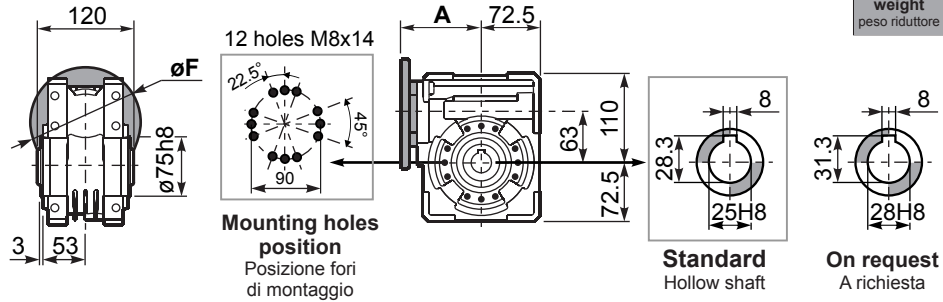

**PQ63FC...** Square flange  
Flangia quadrata

**PQ63F1...** Round flange  
Flangia rotonda

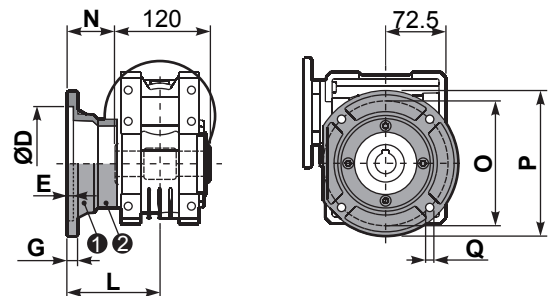
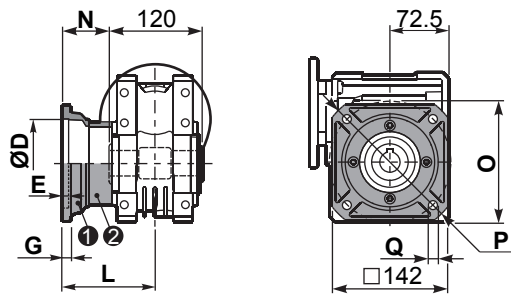

type B	øD	E	G	L	N	O	P	Q	kit code
FC	115 <sup>+0.20</sup> / <sub>+0.15</sub>	6	12	86	26	150	180	11	① KQ63.9.010 ② -
FL	115 <sup>+0.20</sup> / <sub>+0.15</sub>	6	12	116	56	150	180	11	① KQ63.9.010 ② K063.0.200

type S	øD	E	G	L	N	O	P	Q	kit code
F1	130 <sup>+0.20</sup> / <sub>+0.15</sub>	7	13	110	50	165	200	13	① KS070.9.013 ② -
F2	115 <sup>+0.20</sup> / <sub>+0.15</sub>	7	13	124	64	150	175	11	① KS063.9.013 ② -
F3	110 <sup>+0.035</sup> / <sub>0</sub>	5	11	90	30	130	160	10	① KS063.9.011 ② -

**PQ63FB...** Feet  
Piedini

**PQ63BR...** Reaction arm  
Braccio di reazione

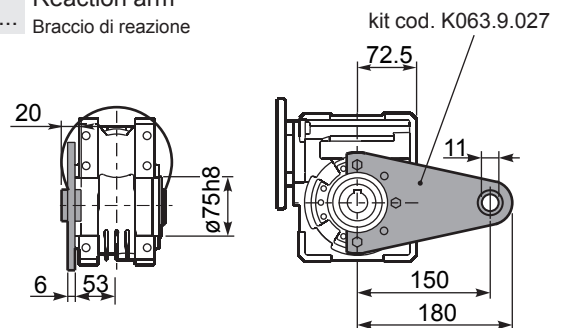
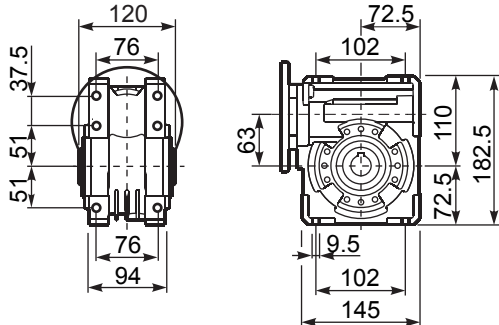

**RQ63FB...** Input shaft  
Albero in entrata

**PQ63.....S...** Single Shaft  
Albero lento semplice

**PQ63.....D...** Double Shaft  
Albero lento bisp.

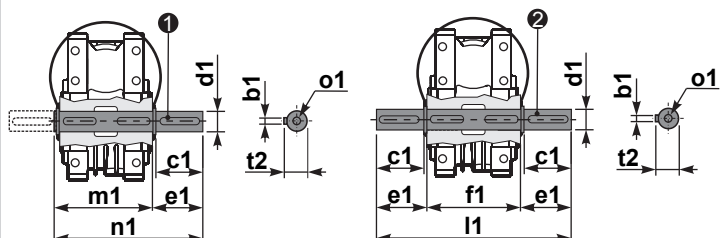
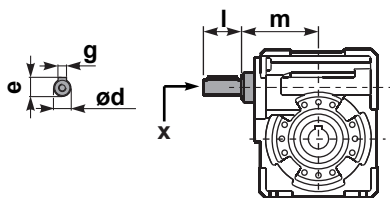

① kit cod. K063.5.028 type B    ② kit cod. K063.5.029 type B

	ød	e	g	l	m	x	kit code
type B	18 h6	20.5	6	45	93	M6x16	① K063.5.006 PAM80 ② K063.5.007 PAM90
type S	19 h6	21.5	6	40	93	M8x20	① KS063.5.008 PAM80 ② KS063.5.009 PAM90

	b1	c1	d1	e1	f1	l1	m1	n1	t2	o1
type B	8	60	25 <sup>-0.005</sup> / <sub>-0.020</sub>	63.2	120	246.4	126.8	190	28	M8x20
type S	-	-	-	-	-	-	-	-	-	-



### QUICK SELECTION / Selezione veloce

input speed ( $n_1$ ) = 1400 min<sup>-1</sup>

Output Speed $n_2$ [min <sup>-1</sup> ]	Ratio $i$	Motor power $P_{1M}$ [kW]	Output torque $M_{2M}$ [Nm]	Service factor f.s.	Nominal power $P_{1R}$ [kW]	Nominal torque $M_{2R}$ [Nm]	Available B5 motor flanges				Available B14 motor flanges			Dynamic efficiency RD	Tooth Module [mm]	Ratios code	
							-C	-D	-E	-F	-R	-T	-U				
							71	80	90	100 112	80	90	100 112				
200	7	4	172	1.1	4.4	190		B	B			B	B		90	3.75	01
140	10	4	240	1.0	3.8	230		B	B			B	B		88	3.75	02
93	15	3	261	1.0	2.9	250		B	B			B	B		85	3.75	03
70	20	2.2	249	1.0	2.2	250		B	B			B	B		83	3.00	04
56	25	1.5	205	1.2	1.8	250	B	B				B			80	2.41	05
45	31	1.5	244	1.1	1.7	270	B	B				B			77	3.75	06
35	40	1.5	295	0.9	1.3	255	B	B				B			72	3.10	07
28	50	0.75	174	1.3	0.95	220	B								68	2.41	08
23	60	0.75	200	1.0	0.75	200	B								65	2.10	09
17.5	80	0.55	177	1.0	0.56	180	B								59	1.53	10
14.0	100	0.55*	206	0.7	0.40	150	B								55	1.23	11

**Motor Flanges Available**  
Flange Motore Disponibili

**B) Supplied with Reduction Bushing**  
Fornito con Bussola di Riduzione

**B) Available on Request without reduction bushing**  
Disponibile a Richiesta senza Bussola di Riduzione

**C) Motor Flange Holes Position**  
Posizione Fori Flangia Motore

**EN** Unit Q75 is supplied with synthetic oil, providing "long life" lubrication. For mounting position V5-V6 please contact us. See table 1 for lubrication and recommended quantity. In table 2 please see possible radial loads and axial loads on the gearbox.

**I** Il riduttore tipo Q75 viene fornito lubrificato a vita con olio sintetico. Per posizioni V5-V6 contattare il ns. servizio tecnico. Vedi tab.1 per oli e quantità consigliati. In tab.2 sono presenti i carichi radiali e assiali applicabili al riduttore.

**D** Für die Lebensdauerschmierung ist das Getriebe der Größe Q75 mit synthetischem Öl befüllt. Bei Einbaulage V5 oder V6 bitten wir um Rücksprache. In Tabelle 1 ist die Schmiermenge und das empfohlene Schmiermittel angegeben. In Tabelle 2 sind die zulässigen Radial- und Axialbelastungen des Getriebes aufgeführt.

**F** Le réducteur de type Q75 est fourni lubrifié à vie avec de l'huile synthétique. Concernant les positions V5.V6, contactez notre service d'assistance technique. Voir tableau 1 concernant les huiles et les quantités conseillées. Les charges radiales et axiales applicables au réducteur sont précisées dans le tableau 2.

**E** El reductor tamaño Q75 se suministra, lubricado de por vida con aceite sintético. Para las posiciones V5 y V6 contactar con nuestro servicio técnico. Ver tabla 1, para cantidades y aceites recomendados. En la tabla 2, se encuentran las cargas radiales y axiales admitidas por el reductor.

### LUBRICATION Q75 Oil Quantity 0.40 Lt.

AGIP Telium VSF 320

SHELL Omala S4 WE 320

For all details on lubrication and plugs check our website **tab. 1**  
Per maggiori dettagli su lubrificazione e tappi olio vedi il nostro sito web

### RADIAL AND AXIAL LOADS

#### Output shaft Albero di uscita

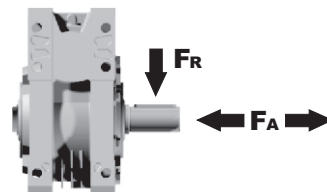

$n_2$ [min <sup>-1</sup> ]	FA [N]	FR [N]
200	460	2300
150	520	2600
100	560	2800
75	620	3100
50	720	3600
25	880	4400
15	1000	5000

#### Input shaft albero in entrata

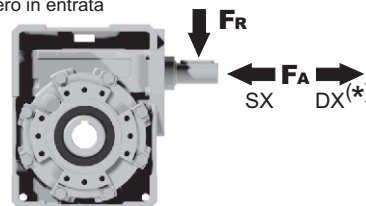

$n_1$ [min <sup>-1</sup> ]	FA [N]	FR [N]
1400	125	630

**\*Strong axial loads in the DX direction are not allowed.**  
Non sono consentiti forti carichi assiali con direzione DX

tab. 2



**PQ75FB...** Basic wormbox  
Riduttore base

Gearbox weight  
peso riduttore **8.70 kg**

M. flanges	Kit code	øF	A
71B5	K023.4.041	160	113.5
80/90B5	K023.4.042	200	115.5
100/112B5	K023.4.043	250	124.5
80B14	K085.4.046	120	115.5
90B14	K085.4.045	140	115.5
100/112B14	K023.4.041	160	113.5

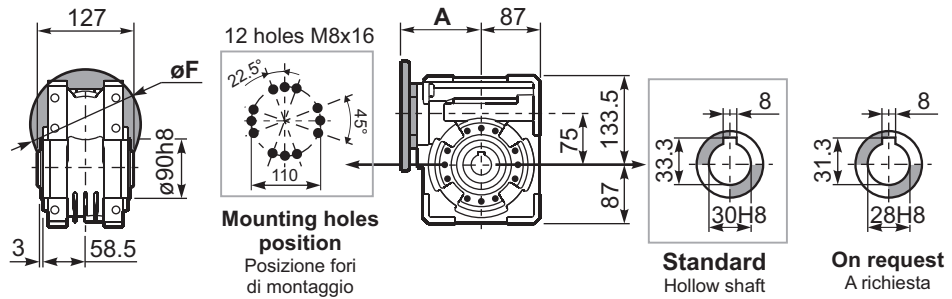

**PQ75FC...** Square flange  
Flangia quadrata

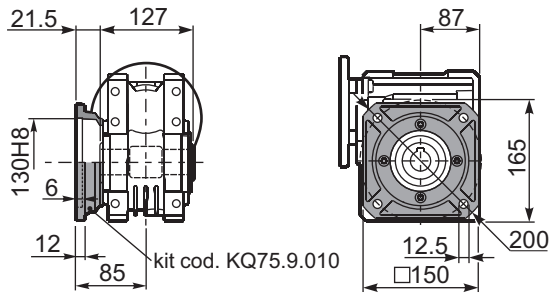

**PQ75FL...** Square flange  
Flangia quadrata

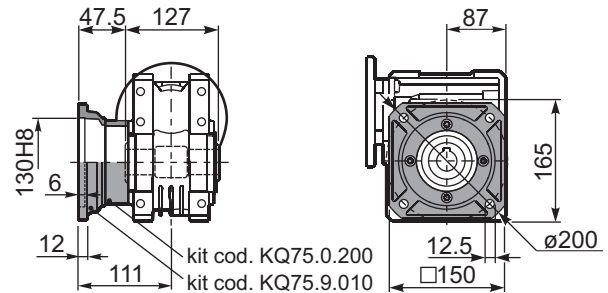

**PQ75FB...** Feet  
Piedini

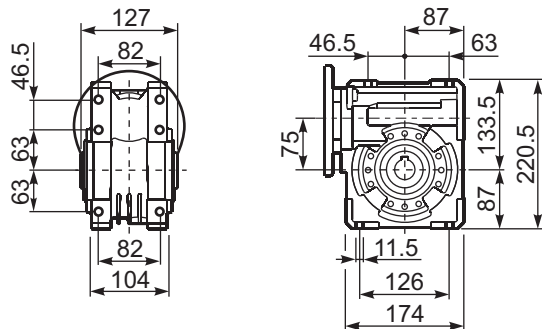

**PQ75BR...** Reaction arm  
Braccio di reazione

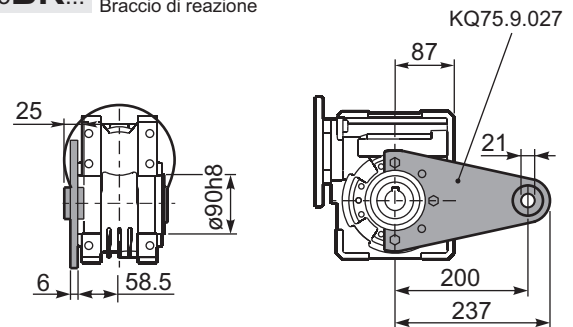

**RQ75FB...** Input shaft  
Albero in entrata

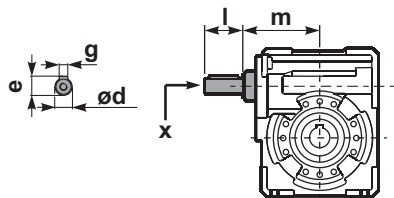

**PQ75.....S...** Single Shaft  
Albero lento semplice

**PQ75.....D...** Double Shaft  
Albero lento bisp.

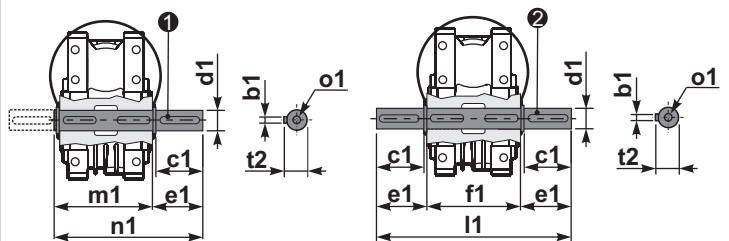

① kit cod. KQ75.5.028 Standard  
kit cod. KQ75.5.026 On request

② kit cod. KQ75.5.029 Standard  
kit cod. KQ75.5.027 On request

	ød	e	g	l	m	x	kit code
type B	25 h6	27.8	8	50	109.5	M8x20	KQ75.5.006 PAM80 K085.5.007 PAM90 K085.5.008 PAM100

	b1	c1	d1	e1	f1	l1	m1	n1	t2	o1
Standard	8	60	30 <sup>-0.005</sup> <sub>-0.020</sub>	65	127	255	134	199	33	M8x20
On request	8	60	28 <sup>-0.005</sup> <sub>-0.020</sub>	65	127	255	134	199	31	M8x20



#### QUICK SELECTION / Selezione veloce

input speed ( $n_1$ ) = 1400 min<sup>-1</sup>

Output Speed $n_2$ [min <sup>-1</sup> ]	Ratio $i$	Motor power $P_{1M}$ [kW]	Output torque $M_{2M}$ [Nm]	Service factor f.s.	Nominal power $P_{1R}$ [kW]	Nominal torque $M_{2R}$ [Nm]	Available B5 motor flanges				Available B14 motor flanges			Dynamic efficiency RD	Tooth Module [mm]	Ratios code	
							-C	-D	-E	-F	-R	-T	-U				
							71	80	90	100 112	80	90	100 112				
200	7	4.0	168	1.5	6.1	257		B	B			B	B		88	4.23	01
140	10	4.0	218	1.3	5.2	284		B	B			B	B		80	4.2	02
100	14	3.0	223	1.4	4.1	305		B	B			B	B		78	4.5	03
70	20	2.2	237	1.2	2.7	294		B	B			B	B		79	3.4	04
64	22	2.2	258	1.1	2.5	294		B	B			B	B		78	3.1	05
50	28	2.2	315	1.1	2.4	347		B	B	B		B	B		75	4.7	06
37	38	1.5	276	1.2	1.8	336	B	B				B	B		71	3.5	07
30	46	1.5	320	1.0	1.5	326	B	B				B	B		68	3.1	08
27	52	1.1	258	1.1	1.2	289	B	B				B	B		66	2.7	09
21	67	1.1	327	0.9	0.97	289	B	B				B	B		65	2.1	10
18.9	74	0.75	220	1.2	0.91	268	B	B				B	B		58	1.9	11
14.6	96	0.55	191	1.3	0.70	242	B	B				B	B		53	1.5	12

**A** Motor Flanges Available  
Flange Motore Disponibili

**B** Supplied with Reduction Bushing  
Fornito con Bussola di Riduzione

**B** Available on Request without reduction bushing  
Disponibile a Richiesta senza Bussola di Riduzione

**C** Motor Flange Holes Position  
Posizione Fori Flangia Motore

**EN** Unit Q85 is supplied with synthetic oil, providing "long life" lubrication. For mounting position V5-V6 please contact us. See table 1 for lubrication and recommended quantity. In table 2 please see possible radial loads and axial loads on the gearbox.

**I** Il riduttore tipo Q85 viene fornito lubrificato a vita con olio sintetico. Per posizioni V5-V6 contattare il ns. servizio tecnico. Vedi tab.1 per oli e quantità consigliati. In tab.2 sono presenti i carichi radiali e assiali applicabili al riduttore.

**D** Für die Lebensdauerschmierung ist das Getriebe der Größe Q85 mit synthetischem Öl befüllt. Bei Einbaulage V5 oder V6 bitten wir um Rücksprache. In Tabelle 1 ist die Schmiermenge und das empfohlene Schmiermittel angegeben. In Tabelle 2 sind die zulässigen Radial- und Axialbelastungen des Getriebes aufgeführt.

**F** Le réducteur de type Q85 est fourni lubrifié à vie avec de l'huile synthétique. Concernant les positions V5.V6, contactez notre service d'assistance technique. Voir tableau 1 concernant les huiles et les quantités conseillées. Les charges radiales et axiales applicables au réducteur sont précisées dans le tableau 2.

**E** El reductor tamaño Q85 se suministra, lubricado de por vida con aceite sintético. Para las posiciones V5 y V6 contactar con nuestro servicio técnico. Ver tabla 1, para cantidades y aceites recomendados. En la tabla 2, se encuentran las cargas radiales y axiales admitidas por el reductor.

#### LUBRICATION Q85 Oil Quantity 1.20 Lt.

**AGIP** Telium VSF 320

**SHELL** Omala S4 WE 320

For all details on lubrication and plugs check our website **tab. 1**  
Per maggiori dettagli su lubrificazione e tappi olio vedi il nostro sito web

#### RADIAL AND AXIAL LOADS

##### Output shaft

Albero di uscita

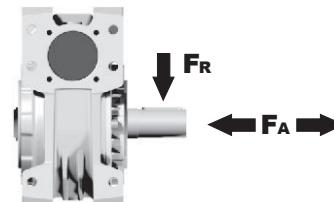

$n_2$ [min <sup>-1</sup> ]	FA [N]	FR [N]
200	500	2500
150	580	2900
100	600	3000
75	700	3500
50	800	4000
25	1000	5000
15	1160	5800

##### Input shaft

albero in entrata

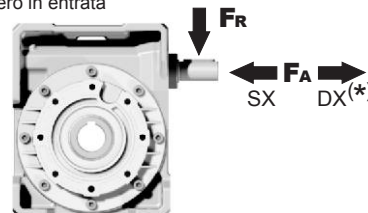

$n_1$ [min <sup>-1</sup> ]	FA [N]	FR [N]
1400	160	809

**\*Strong axial loads in the DX direction are not allowed.**  
Non sono consentiti forti carichi assiali con direzione DX

tab. 2

PQ85**FB**... Basic wormbox  
Riduttore base

Gearbox weight  
peso riduttore **12.1 kg**

M. flanges	Kit code	øF	A
71B5	K023.4.041	160	116
80/90B5	K023.4.042	200	118
100/112B5	K023.4.043	250	127
80B14	K085.4.046	120	118
90B14	K085.4.045	140	118
100/112B14	K023.4.041	160	116

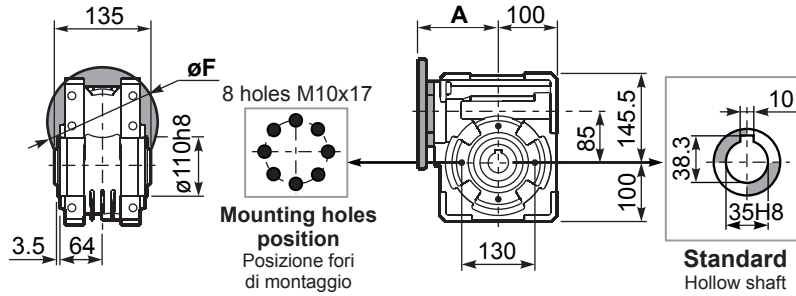

PQ85**FC**... Output flange  
Flangia uscita

PQ85**F1**... Output flange  
Flangia uscita

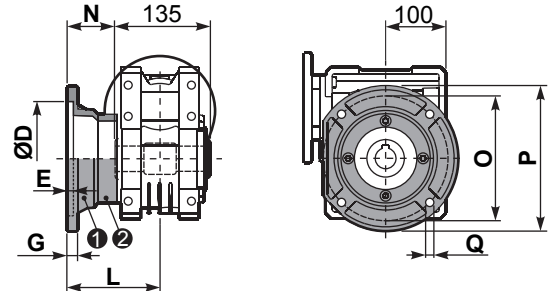
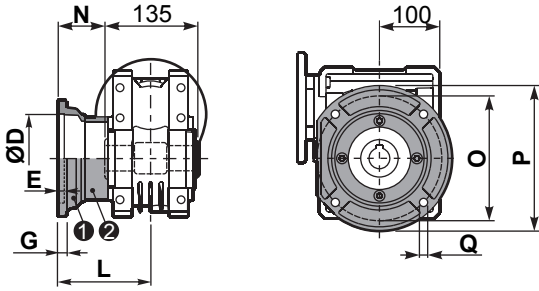

type B	øD	E	G	L	N	O	P	Q	kit code
FC	152 <sup>+0.06</sup> / <sub>+0.00</sub>	5	16	108	40.5	176	205	13	① K085.9.010 ② -
FL	152 <sup>+0.06</sup> / <sub>+0.00</sub>	5	16	148.5	81	176	205	13	① K085.9.010 ② K085.0.201

type S	øD	E	G	L	N	O	P	Q	kit code
F1	130 H7	5	13	117.5	50	165	200	11.5	① KS085.9.012 ② -
F2	152 <sup>+0.06</sup> / <sub>+0.00</sub>	5	15	147.5	80	180	205	12.5	① KS085.9.013 ② -
F4	130 H7	5	13	106.5	39	165	200	13	① KS085.9.015 ② -

PQ85**FB**... Feet  
Piedini

PQ85**BR**... Reaction arm  
Braccio di reazione

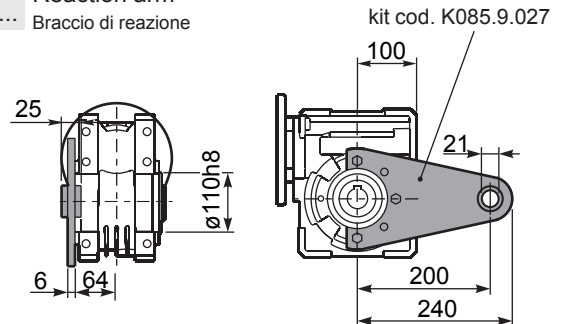
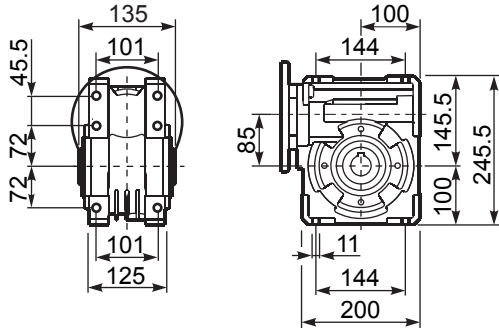

RQ85**FB**... Input shaft  
Albero in entrata

PQ85.....**S**... Single Shaft  
Albero lento semplice

PQ85.....**D**... Double Shaft  
Albero lento bisp.

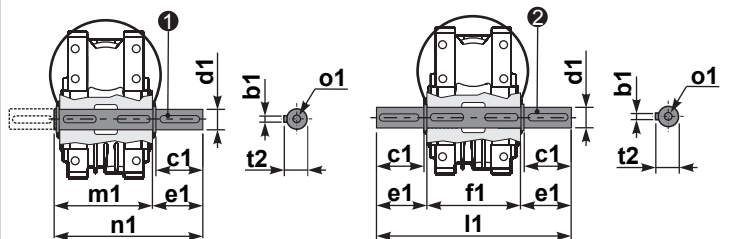
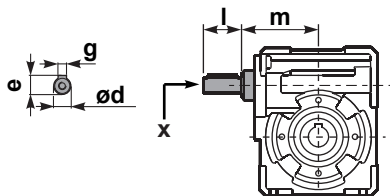

① kit cod. K085.5.028 type B    ② kit cod. K085.5.029 type B

	ød	e	g	l	m	x	kit code
type B	25 h6	28	8	50	112	M8x20	① K085.5.007 PAM90 ② K085.5.008 PAM100
type S	24 h6	27	8	50	112	M8x20	① KS085.5.009 PAM90 ② KS085.5.011 PAM100

	b1	c1	d1	e1	f1	l1	m1	n1	t2	o1
type B	10	60	35 <sup>-0.005</sup> / <sub>-0.020</sub>	73.5	135	282	141	214.5	38	M10x23
type S	-	-	-	-	-	-	-	-	-	-



#### QUICK SELECTION / Selezione veloce

input speed ( $n_1$ ) = 1400 min<sup>-1</sup>

Output Speed $n_2$ [min <sup>-1</sup> ]	Ratio $i$	Motor power $P_{1M}$ [kW]	Output torque $M_{2M}$ [Nm]	Service factor f.s.	Nominal power $P_{1R}$ [kW]	Nominal torque $M_{2R}$ [Nm]	Available B5 motor flanges					Available B14 motor flanges				Dynamic efficiency RD	Tooth Module [mm]	Ratios code	
							-C	-D	-E	-F	-G	-R	-T	-U	-V				
							71	80	90	100 112	132	80	90	100 112	132				
200	7	7.5	315	1.5	11.5	483		B	B				B	B			88	5.5	01
140	10	7.5	440	1.2	9.0	525		B	B				B	B			86	5.4	02
88	16	5.5	492	1.1	6.0	536		B	B				B	B			82	5.3	03
70	20	4.0	447	1.2	4.9	546		B	B				B	B			82	4.5	04
61	23	3.0	377	1.4	4.1	515		B	B				B	B			80	3.9	05
47	30	3.0	467	1.4	4.2	651		B	B				B	B			76	5.6	06
37	38	3.0	583	1.1	3.3	641		B	B				B	B			75	4.7	07
31	45	2.2	493	1.2	2.7	599		B	B				B	B			73	4.0	08
26	53	2.2	557	1.1	2.5	620		B	B				B	B			70	3.5	09
22	64	1.5	452	1.2	1.8	536	B	B					B				69	2.9	10
16.7	84	1.1	410	1.2	1.3	494	B	B					B				65	2.2	11
14.1	99	1.1	446	1.1	1.2	483	B	B					B				60	1.9	12

**Motor Flanges Available**  
Flange Motore Disponibili

**B) Supplied with Reduction Bushing**  
Fornito con Bussola di Riduzione

**B) Available on Request without reduction bushing**  
Disponibile a Richiesta senza Bussola di Riduzione

**C) Motor Flange Holes Position**  
Posizione Fori Flangia Motore

**EN** Unit Q11 is supplied without lubricant and equipped with a breather, level and drain plugs. User can add mineral oil keeping existing plugs. Should the user wish to fill it with synthetic oil, it is recommended to replace the existing plugs with a closed plug.  
See table 1 for lubrication and recommended quantity. In table 2 please see possible radial loads and axial loads on the gearbox.

**I** Il riduttore tipo Q11 è fornito privo di lubrificazione con tappi di sfiato, livello e scarico olio. L'utente può immettere olio minerale mantenendo i tappi esistenti. Se immetterà olio sintetico, dovrà sostituire i tappi esistenti con altri tipo chiuso.  
Tab.1 per oli e quantità consigliati.  
Tab.2 carichi radiali e assiali applicabili al riduttore.

**D** Das Getriebe der Baugröße Q11 wird ohne Schmiermittel geliefert. Es ist jedoch mit Einfüllschraube, Überdruckventil und Ablassschraube ausgerüstet. Das benötigte mineralische Öl kann über die Einfüllschraube eingefüllt werden. Sollte synthetisches Öl bevorzugt werden, so ist sind das eingebaute Überdruckventil durch eine geschlossenen Schraube zu ersetzen.  
In Tabelle 1 ist die Schmiermenge und das empfohlene Schmiermittel angegeben.  
In Tabelle 2 sind die zulässigen Radial - und Axialbelastungen des Getriebes aufgeführt.

**F** Le réducteur de type Q11 est fourni sans lubrification et avec un bouchon de remplissage, de niveau et d'évacuation de l'huile. L'utilisateur peut y verser de l'huile minérale en conservant les bouchons existants.  
S'il y versera de l'huile synthétique, il devra substituer les bouchons existants avec d'autres bouchons de type fermé.  
Voir tableau 1 concernant les huiles et les quantités conseillées.  
Voir tableau 2 concernant les charges radiales et axiales applicables au réducteur.

**E** El reductor tamaño Q11 se suministra sin lubricante, provisto de tapones de respiración, nivel y descarga de aceite. El usuario puede utilizar aceite mineral, manteniendo los tapones existentes. Si prefiere utilizar aceite sintético deberá sustituir los tapones existentes por tapones ciegos. La prerreducción se suministra con tapones ciegos, lubricado de por vida con aceite sintético.  
Ver tabla 1, para cantidades y aceites recomendados.  
En la tabla 2, se encuentran las cargas radiales y axiales admitidas por el reductor.

B3	B6	B7	B8	V5	V6
2.00 LT	1.35 LT	1.35 LT	2.00LT	2.00 LT	2.00LT

**AGIP Blasias 460**

For all details on lubrication and plugs check our website [tab. 1](#)  
Per maggiori dettagli su lubrificazione e tappi olio vedi il nostro sito web

#### RADIAL AND AXIAL LOADS

**Output shaft**  
Albero di uscita

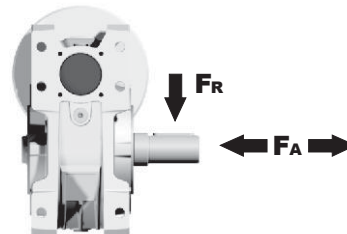

$n_2$ [min <sup>-1</sup> ]	FA [N]	FR [N]
200	600	2900
150	700	3300
100	750	3600
75	800	4000
50	920	4600
25	1200	6000
15	1400	7000

**Input shaft**  
albero in entrata

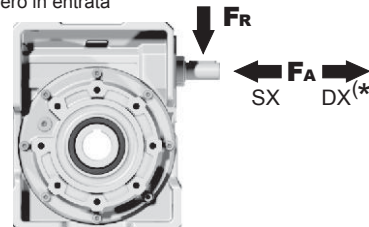

$n_1$ [min <sup>-1</sup> ]	FA [N]	FR [N]
1400	228	1140

**\*Strong axial loads in the DX direction are not allowed.**  
Non sono consentiti forti carichi assiali con direzione DX

tab. 2

**PQ11FB...** Basic wormbox  
Riduttore base

Gearbox weight  
peso riduttore **35.0 kg**

M. flanges	Kit code	øF	A
71B5	K023.4.041	160	135.5
80/90B5	K023.4.042	200	137.5
100/112B5	K023.4.043	250	146.5
132B5	-	300	187
80B14	K085.4.046	120	137.5
90B14	K085.4.045	140	137.5
100/112B14	K023.4.041	160	135.5
132B14	-	200	187

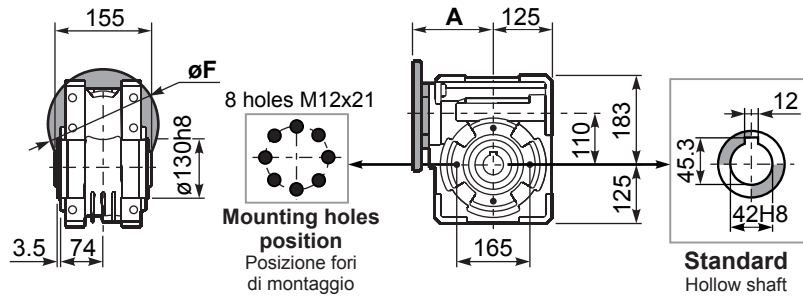

**PQ11FC...** Output flange  
Flangia uscita

**PQ11F1...** Output flange  
Flangia uscita

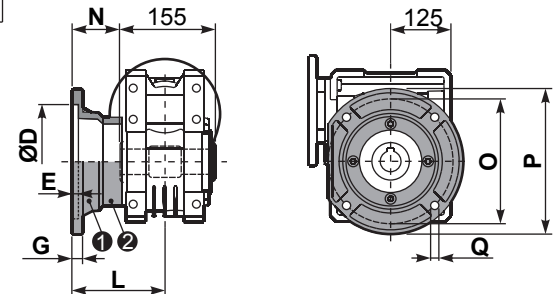
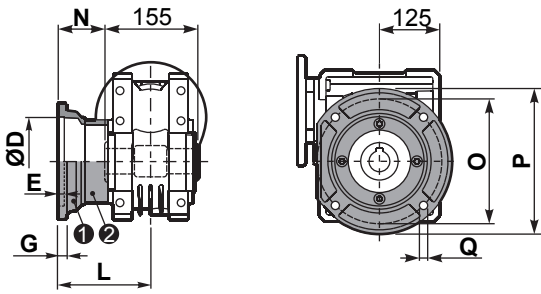

type B	øD	E	G	L	N	O	P	Q	kit code
FC	170 <sup>+0.083</sup> / <sub>+0.043</sub>	11	16.5	131.5	54	230	270	13	① K110.9.010 ② -
FL	170 <sup>+0.083</sup> / <sub>+0.043</sub>	11	16.5	179.5	102	230	270	13	① K110.9.011 ② -

type S	øD	E	G	L	N	O	P	Q	kit code
F1	180 <sup>+0.040</sup> / <sub>0</sub>	5	18	150	72.5	215	250	15	① KS110.9.014 ② -
F2	170 <sup>+0.083</sup> / <sub>+0.043</sub>	9.5	15	178	100.5	230	270	13	① KS110.9.012 ② -
F3	180 <sup>+0.040</sup> / <sub>0</sub>	5	18	130	52.5	215	250	15	① KS110.9.013 ② -

**PQ11FB...** Feet  
Piedini

**PQ11BR...** Reaction arm  
Braccio di reazione

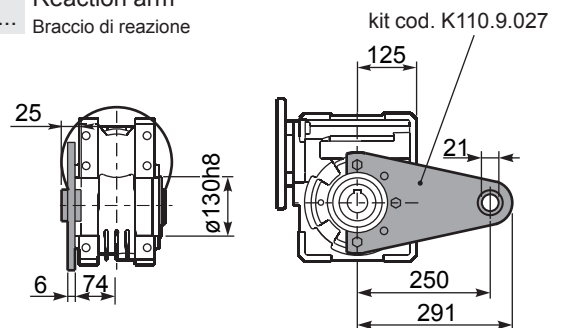
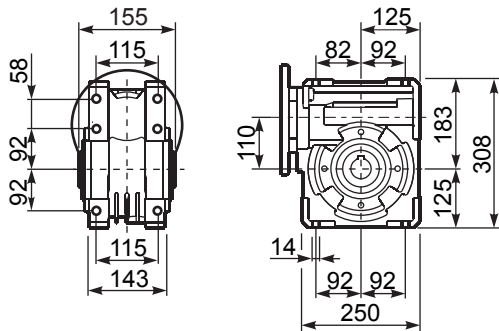

**RQ11FB...** Input shaft  
Albero in entrata

**PQ11.....S...** Single Shaft  
Albero lento semplice

**PQ11.....D...** Double Shaft  
Albero lento bisp.

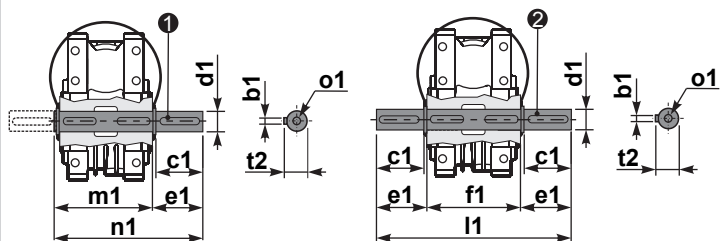
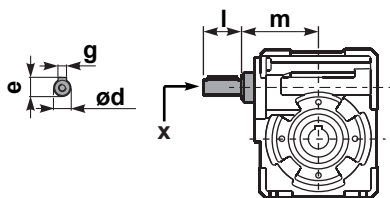

① kit cod. K110.5.028 type B      ② kit cod. K110.5.029 type B

	ød	e	g	l	m	x	kit code
type B	25 h6	28	8	50	131.5	M8x20	① K085.5.007 PAM90 ② K085.5.008 PAM100
type S	24 h6	27	8	50	131.5	M8x20	① KS085.5.009 PAM90 ② KS085.5.011 PAM100

	b1	c1	d1	e1	f1	l1	m1	n1	t2	o1
type B	12	75	42 <sup>-0.005</sup> / <sub>-0.020</sub>	96.5	155	348	163.5	260	45	M12x32
type S	-	-	-	-	-	-	-	-	-	-



### QUICK SELECTION / Selezione veloce

input speed ( $n_1$ ) = 1400 min<sup>-1</sup>

Output Speed $n_2$ [min <sup>-1</sup> ]	Ratio $i$	Motor power $P_{1M}$ [kW]	Output torque $M_{2M}$ [Nm]	Service factor f.s.	Nominal power $P_{1R}$ [kW]	Nominal torque $M_{2R}$ [Nm]	Available B5 motor flanges			B14 motor flanges not available				Dynamic efficiency RD	Tooth Module [mm]	Ratios code
							-E	-F	-G	-	-	-	-			
							90	100 112	132	-	-	-	-			
187	<b>7.5</b>	7.5	345	2.1	<b>16.1</b>	<b>741</b>								90	6.11	01
140	<b>10</b>	7.5	455	1.8	<b>13.5</b>	<b>820</b>								89	6.45	02
93	<b>15</b>	7.5	668	1.4	<b>10.3</b>	<b>917</b>								87	6.72	03
70	<b>20</b>	7.5	870	1.0	<b>7.8</b>	<b>905</b>								85	5.24	04
56	<b>25</b>	5.5	788	1.2	<b>6.5</b>	<b>931</b>								84	4.28	05
46.7	<b>30</b>	5.5	900	1.2	<b>6.4</b>	<b>1047</b>								80	6.91	06
35	<b>40</b>	4.0	851	1.2	<b>4.9</b>	<b>1043</b>								78	5.36	07
28	<b>50</b>	4.0	1023	0.9	<b>3.8</b>	<b>972</b>								75	4.35	08
23.3	<b>60</b>	3.0	896	1.0	<b>3.1</b>	<b>928</b>	B							73	3.65	09
17.5	<b>80</b>	2.2	816	1.0	<b>2.3</b>	<b>853</b>	B							68	2.76	10
14	<b>100</b>	1.5	655	1.1	<b>1.7</b>	<b>742</b>	B							64	2.23	11

**Motor Flanges Available**  
Flange Motore Disponibili

**B) Supplied with Reduction Bushing**  
Fornito con Bussola di Riduzione

**B) Available on Request without reduction bushing**  
Disponibile a Richiesta senza Bussola di Riduzione

**C) Motor Flange Holes Position**  
Posizione Fori Flangia Motore

**EN** Unit Q13 is supplied without lubricant and equipped with a breather, level and drain plugs. User can add mineral oil keeping existing plugs. Should the user wish to fill it with synthetic oil, it is recommended to replace the existing plugs with a closed plug. See table 1 for lubrication and recommended quantity. In table 2 please see possible radial loads and axial loads on the gearbox.

**I** Il riduttore tipo Q13 è fornito privo di lubrificazione con tappi di sfiato, livello e scarico olio. L'utente può immettere olio minerale mantenendo i tappi esistenti. Se immetterà olio sintetico, dovrà sostituire i tappi esistenti con altri tipo chiuso. Tab.1 per oli e quantità consigliati. Tab.2 carichi radiali e assiali applicabili al riduttore.

**D** Das Getriebe der Baugröße Q13 wird ohne Schmiermittel geliefert. Es ist jedoch mit Einfüllschraube, Überdruckventil und Ablassschraube ausgerüstet. Das benötigte mineralische Öl kann über die Einfüllschraube eingefüllt werden. Sollte synthetisches Öl bevorzugt werden, so ist sind das eingebaute Überdruckventil durch eine geschlossenen Schraube zu ersetzen. In Tabelle 1 ist die Schmiermenge und das empfohlene Schmiermittel angegeben. In Tabelle 2 sind die zulässigen Radial - und Axialbelastungen des Getriebes aufgeführt.

**F** Le réducteur de type Q13 est fourni sans lubrification et avec un bouchon de remplissage, de niveau et d'évacuation de l'huile. L'utilisateur peut y verser de l'huile minérale en conservant les bouchons existants. S'il y versera de l'huile synthétique, il devra substituer les bouchons existants avec d'autres bouchons de type fermé. Voir tableau 1 concernant les huiles et les quantités conseillées. Voir tableau 2 concernant les charges radiales et axiales applicables au réducteur.

**E** El reductor tamaño Q13 se suministra sin lubricante, provisto de tapones de respiración, nivel y descarga de aceite. El usuario puede utilizar aceite mineral, manteniendo los tapones existentes. Si prefiere utilizar aceite sintético deberá sustituir los tapones existentes por tapones ciegos. La prerreducción se suministra con tapones ciegos, lubricado de por vida con aceite sintético. Ver tabla 1, para cantidades y aceites recomendados. En la tabla 2, se encuentran las cargas radiales y axiales admitidas por el reductor.

B3	B6	B7	B8	V5	V6
4.50 LT	3.50 LT	3.50 LT	3.30LT	4.50 LT	3.30LT

AGIP Blasias 460

For all details on lubrication and plugs check our website [tab. 1](#)  
Per maggiori dettagli su lubrificazione e tappi olio vedi il nostro sito web

### RADIAL AND AXIAL LOADS

**Output shaft**  
Albero di uscita

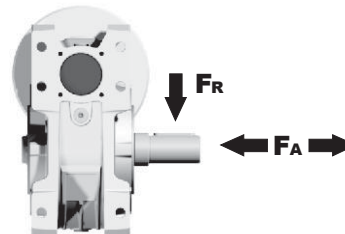

$n_2$ [min <sup>-1</sup> ]	FA [N]	FR [N]
200	960	4800
150	1100	5500
100	1240	6200
75	1380	6900
50	1560	7800
25	2000	10000
15	2400	12000

**Input shaft**  
albero in entrata

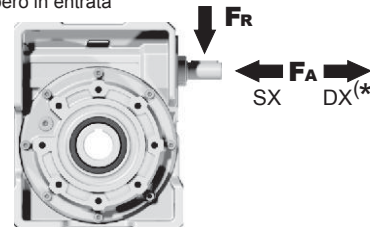

$n_1$ [min <sup>-1</sup> ]	FA [N]	FR [N]
1400	300	1500

\*Strong axial loads in the DX direction are not allowed.  
Non sono consentiti forti carichi assiali con direzione DX

tab. 2

PQ13**FB**... Basic wormbox  
Riduttore base

Gearbox weight  
peso riduttore **48.0 kg**

M. flanges	Kit code	øF	A
90B5	KQ13.4.041	200	180
100/112B5	KQ13.4.042	250	180
132B5	KQ13.4.043	300	180

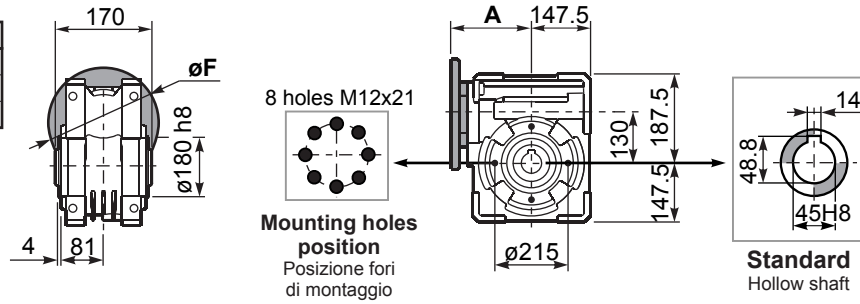

PQ13**FC**... Square flange  
Flangia quadrata

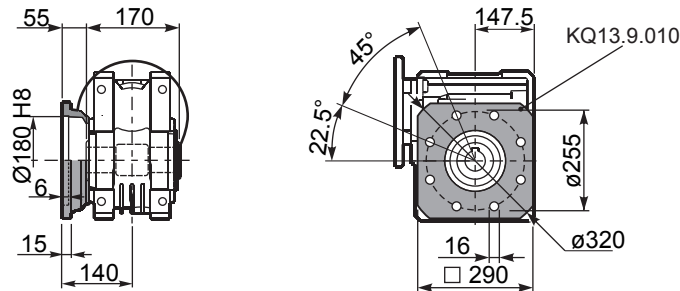

PQ13**FB**... Feet  
Piedini

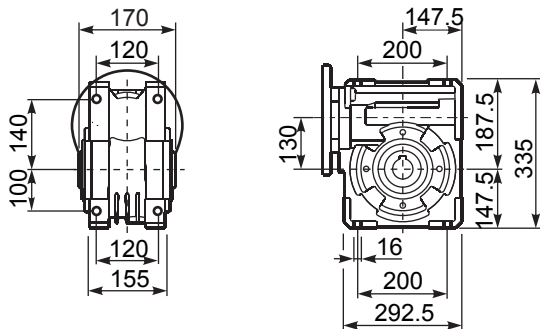

PQ13**BR**... Reaction arm  
Braccio di reazione

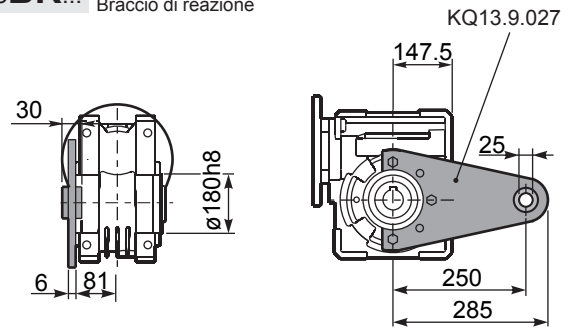

PQ13.....**S**... Single Shaft  
Albero lento semplice

PQ13.....**D**... Double Shaft  
Albero lento bisp.

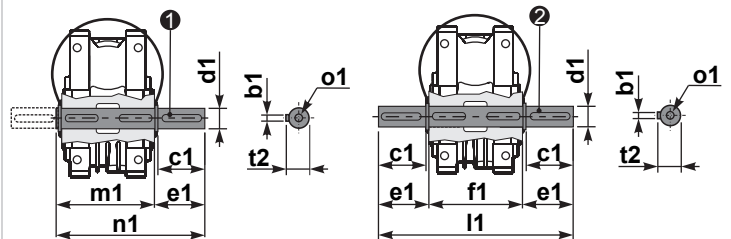

① kit cod. KQ13.5.028 type B

② kit cod. KQ13.5.029 type B

	b1	c1	d1	e1	f1	l1	m1	n1	t2	o1
type	14	80	45 <sup>-0.005</sup> <sub>-0.020</sub>	85	170	340	180	265	48.5	M16
type	-	-	-	-	-	-	-	-	-	-



#### QUICK SELECTION / Selezione veloce

input speed ( $n_1$ ) = 1400 min<sup>-1</sup>

Output Speed $n_2$ [min <sup>-1</sup> ]	Ratio $i$	Motor power $P_{1M}$ [kW]	Output torque $M_{2M}$ [Nm]	Service factor f.s.	Nominal power $P_{1R}$ [kW]	Nominal torque $M_{2R}$ [Nm]	Available B5 motor flanges			B14 motor flanges not available				Dynamic efficiency  RD	Tooth Module  [mm]	Ratios code 
							-F	-G	-H	-	-	-	-			
							100	132	160	-	-	-	-			
187	7.5	15	698	1.7	25.8	1200		B						91	5.5	01
140	10	15	921	1.3	20.2	1240		B						90	6.155	02
93	15	11	990	1.3	13.9	1250		B						88	5.5	03
70	20	11	1291	1.0	11.1	1300		B						86	6.155	04
56	25	9	1289	0.9	8.4	1200		B						84	5	05
46.7	30	7.5	1274	0.9	7.1	1200	B							83	4.193	06
35	40	7.5	1596	1.0	7.3	1550	B							78	6.155	07
28	50	5.5	1426	1.0	5.4	1400	B							76	5	08
23.3	60	4	1195	1.1	4.2	1260	B							73	4.193	09
17.5	80	3	1113	1.0	3.1	1150								68	3.17	10
14	100	2.2	960	1.0	2.3	1000								64	2.55	11

**A) Motor Flanges Available**  
Flange Motore Disponibili

**B) Supplied with Reduction Bushing**  
Fornito con Bussola di Riduzione

**B) Available on Request without reduction bushing**  
Disponibile a Richiesta senza Bussola di Riduzione

**C) Motor Flange Holes Position**  
Posizione Fori Flangia Motore

**EN** Unit Q15 is supplied without lubricant and equipped with a breather, level and drain plugs. User can add mineral oil keeping existing plugs. Should the user wish to fill it with synthetic oil, it is recommended to replace the existing plugs with a closed plug. See table 1 for lubrication and recommended quantity. In table 2 please see possible radial loads and axial loads on the gearbox.

**I** Il riduttore tipo Q15 è fornito privo di lubrificazione con tappi di sfiato, livello e scarico olio. L'utente può immettere olio minerale mantenendo i tappi esistenti. Se immetterà olio sintetico, dovrà sostituire i tappi esistenti con altri tipo chiuso. Tab.1 per oli e quantità consigliati. Tab.2 carichi radiali e assiali applicabili al riduttore.

**D** Das Getriebe der Baugröße Q15 wird ohne Schmiermittel geliefert. Es ist jedoch mit Einfüllschraube, Überdruckventil und Ablassschraube ausgerüstet. Das benötigte mineralische Öl kann über die Einfüllschraube eingefüllt werden. Sollte synthetisches Öl bevorzugt werden, so ist sind das eingebaute Überdruckventil durch eine geschlossenen Schraube zu ersetzen. In Tabelle 1 ist die Schmiermenge und das empfohlene Schmiermittel angegeben. In Tabelle 2 sind die zulässigen Radial - und Axialbelastungen des Getriebes aufgeführt.

**F** Le réducteur de type Q15 est fourni sans lubrification et avec un bouchon de remplissage, de niveau et d'évacuation de l'huile. L'utilisateur peut y verser de l'huile minérale en conservant les bouchons existants. S'il y versera de l'huile synthétique, il devra substituer les bouchons existants avec d'autres bouchons de type fermé. Voir tableau 1 concernant les huiles et les quantités conseillées. Voir tableau 2 concernant les charges radiales et axiales applicables au réducteur.

**E** El reductor tamaño Q15 se suministra sin lubricante, provisto de tapones de respiración, nivel y descarga de aceite. El usuario puede utilizar aceite mineral, manteniendo los tapones existentes. Si prefiere utilizar aceite sintético deberá sustituir los tapones existentes por tapones ciegos. La prerreducción se suministra con tapones ciegos, lubricado de por vida con aceite sintético. Ver tabla 1, para cantidades y aceites recomendados. En la tabla 2, se encuentran las cargas radiales y axiales admitidas por el reductor.

B3	B6	B7	B8	V5	V6
7.00 LT	5.40 LT	5.40 LT	5.10 LT	7.00 LT	5.10 LT

AGIP Blasias 460

For all details on lubrication and plugs check our website [tab. 1](#)  
Per maggiori dettagli su lubrificazione e tappi olio vedi il nostro sito web

#### RADIAL AND AXIAL LOADS

**Output shaft**  
Albero di uscita

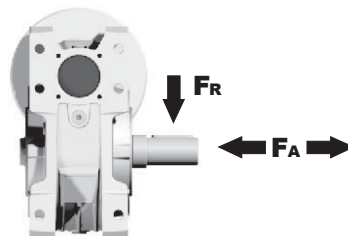

$n_2$ [min <sup>-1</sup> ]	FA [N]	FR [N]
200	1300	6500
150	1440	7200
100	1640	8200
75	1800	9000
50	2120	10600
25	2700	13500
15	3300	16500

**Input shaft**  
albero in entrata

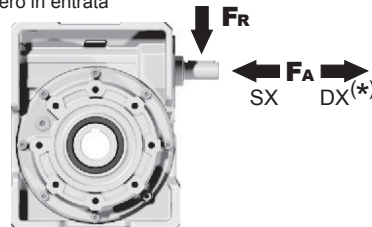

$n_1$ [min <sup>-1</sup> ]	FA [N]	FR [N]
1400	400	2000

\*Strong axial loads in the DX direction are not allowed.  
Non sono consentiti forti carichi assiali con direzione DX

tab. 2



PQ15**FB**... Basic wormbox  
Riduttore base

Gearbox weight  
peso riduttore **84.0 kg**

M. flanges	Kit code	øF	A
100/112B5	KQ15.4.042	250	210
132B5	KQ15.4.043	300	210
160B5	KQ15.4.044	350	210

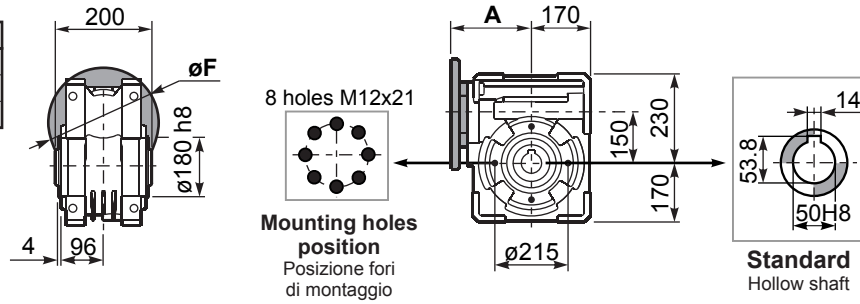

PQ15**FC**... Square flange  
Flangia quadrata

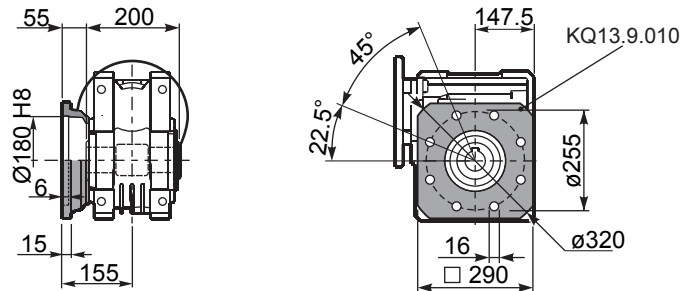

PQ15**FB**... Feet  
Piedini

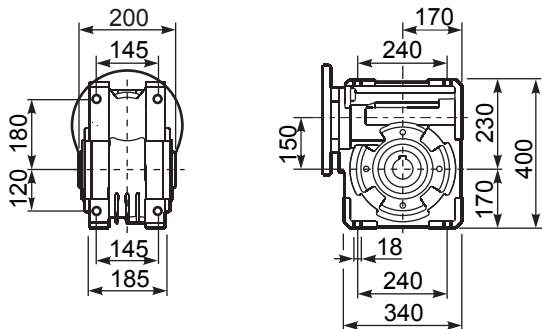

PQ15**BR**... Reaction arm  
Braccio di reazione

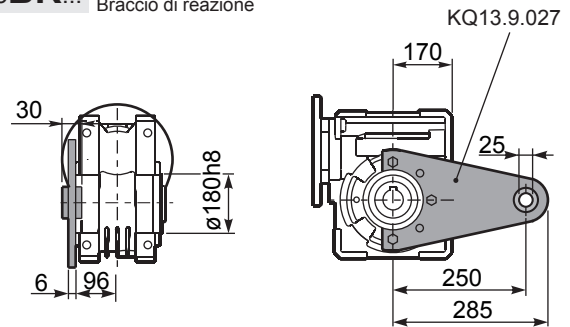

PQ15.....**S**... Single Shaft  
Albero lento semplice

PQ15.....**D**... Double Shaft  
Albero lento bisp.

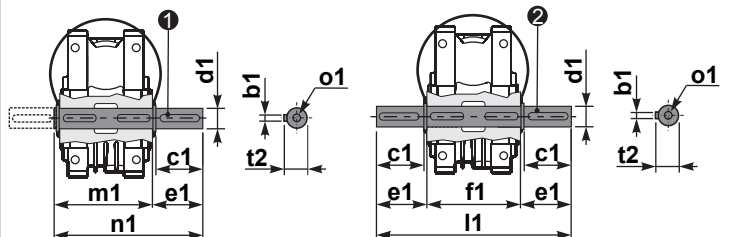

① kit cod. KQ15.5.028 type B

② kit cod. KQ15.5.029 type B

	b1	c1	d1	e1	f1	l1	m1	n1	t2	o1
type	14	82	50 <sup>-0.005</sup> <sub>-0.020</sub>	87	200	374	210	297	53.5	M16
type	-	-	-	-	-	-	-	-	-	-

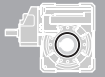

### QUICK SELECTION / Selezione veloce

input speed ( $n_1$ ) = 1400 min<sup>-1</sup>

Output Speed $n_2$ [min <sup>-1</sup> ]	Ratio $i$	Motor power $P_{1M}$ [kW]	Output torque $M_{2M}$ [Nm]	Service factor f.s.	Nominal power $P_{1R}$ [kW]	Nominal torque $M_{2R}$ [Nm]	Available B5 motor flanges			Available B14 motor flanges		Dynamic efficiency <b>RD</b>	Tooth Module  [mm]	Ratios code 
							-A	-B	-C	-P	-Q			
							56	63	71	63	71			
47	<b>30.1</b>	0.25	38	1.4	<b>0.36</b>	<b>55</b>				<b>C</b>		74	2.2	01
33	<b>43.0</b>	0.25	53	1.0	<b>0.26</b>	<b>55</b>				<b>C</b>		72	2.2	02
23	<b>60.2</b>	0.25	62	0.9	<b>0.22</b>	<b>55</b>				<b>C</b>		60	2.4	03
15.5	<b>90.3</b>	0.12	42	1.3	<b>0.16</b>	<b>55</b>				<b>C</b>		57	1.6	04
11.6	<b>120</b>	0.12	52	1.1	<b>0.13</b>	<b>55</b>				<b>C</b>		53	2.5	05
8.8	<b>159</b>	0.12	64	0.9	<b>0.10</b>	<b>55</b>				<b>C</b>		49	1.8	06
7.1	<b>198</b>	0.12*	55	<0.8	<b>0.09</b>	<b>55</b>				<b>C</b>		47	1.5	07
5.4	<b>258</b>	0.12*	55	<0.8	<b>0.07</b>	<b>55</b>				<b>C</b>		45	1.2	08
4.7	<b>301</b>	0.12*	39	<0.8	<b>0.05</b>	<b>39</b>				<b>C</b>		40	1.0	09
3.2	<b>439</b>	0.12*	39	<0.8	<b>0.04</b>	<b>39</b>				<b>C</b>		36	0.72	10

**A) Motor Flanges Available**  
Flange Motore Disponibili

**B) Supplied with Reduction Bushing**  
Fornito con Bussola di Riduzione

**Available on Request without reduction bushing**  
Disponibile a Richiesta senza Bussola di Riduzione

**C) Motor Flange Holes Position**  
Posizione Fori Flangia Motore

\* Power higher than the maximum one which can be supported by the gearbox. Select according to the torque  $M_{2R}$   
Potenza superiore a quella massima sopportabile dal riduttore. Selezionare in base al momento torcente  $M_{2R}$

**EN** Unit **P4Q** is supplied with synthetic oil, providing "long life" lubrication. For mounting position V5-V6 please contact us. See table 1 for lubrication and recommended quantity. In table 2 please see possible radial loads and axial loads on the gearbox.

**I** Il riduttore tipo **P4Q** viene fornito lubrificato a vita con olio sintetico. Per posizioni V5-V6 contattare il ns. servizio tecnico. Vedi tab.1 per oli e quantità consigliati. In tab.2 sono presenti i carichi radiali e assiali applicabili al riduttore.

**D** Für die Lebensdauerschmierung ist das Getriebe der Größe **P4Q** mit synthetischem Öl befüllt. Bei Einbaulage V5 oder V6 bitten wir um Rücksprache. In Tabelle 1 ist die Schmiermenge und das empfohlene Schmiermittel angegeben. In Tabelle 2 sind die zulässigen Radial- und Axialbelastungen des Getriebes aufgeführt.

**F** Le réducteur de type **P4Q** est fourni lubrifié à vie avec de l'huile synthétique. Concernant les positions V5.V6, contactez notre service d'assistance technique. Voir tableau 1 concernant les huiles et les quantités conseillées. Les charges radiales et axiales applicables au réducteur sont précisées dans le tableau 2.

**E** El reductor tamaño **P4Q** se suministra, lubricado de por vida con aceite sintético. Para las posiciones V5 y V6 contactar con nuestro servicio técnico. Ver tabla 1, para cantidades y aceites recomendados. En la tabla 2, se encuentran las cargas radiales y axiales admitidas por el reductor.

**LUBRICATION P4Q Oil**  
Common lubrication 0.17 l ( A + B ).

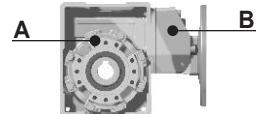

<b>AGIP</b> Telium VSF 320	<b>SHELL</b> Omala S4 WE 320
----------------------------	------------------------------

For all details on lubrication and plugs check our website **tab. 1**  
Per maggiori dettagli su lubrificazione e tappi olio vedi il nostro sito web

### RADIAL AND AXIAL LOADS

**Output shaft**  
Albero di uscita

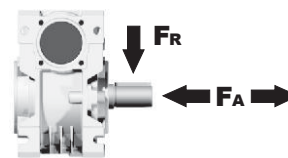

$n_2$ [min <sup>-1</sup> ]	FA [N]	FR [N]
75	240	1200
50	260	1400
25	300	1800
15-6	400	2000

**Input shaft**  
albero in entrata

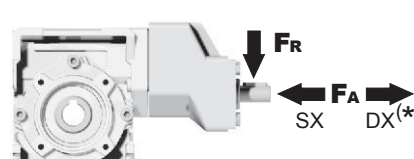

$n_1$ [min <sup>-1</sup> ]	FA [N]	FR [N]
1400	44	220

\*Strong axial loads in the DX direction are not allowed.  
Non sono consentiti forti carichi assiali con direzione DX

tab. 2

**PP4QFB...** Basic wormbox  
Riduttore base

M. flanges	Kit code	øF	A
<b>56B5</b>	K050.4.046	120	143.5
<b>63B5</b>	K050.4.041	138	145.5
<b>71B5</b>	K050.4.042	160	143
<b>63B14</b>	K050.4.047	90	145.5
<b>71B14</b>	K050.4.045	105	143

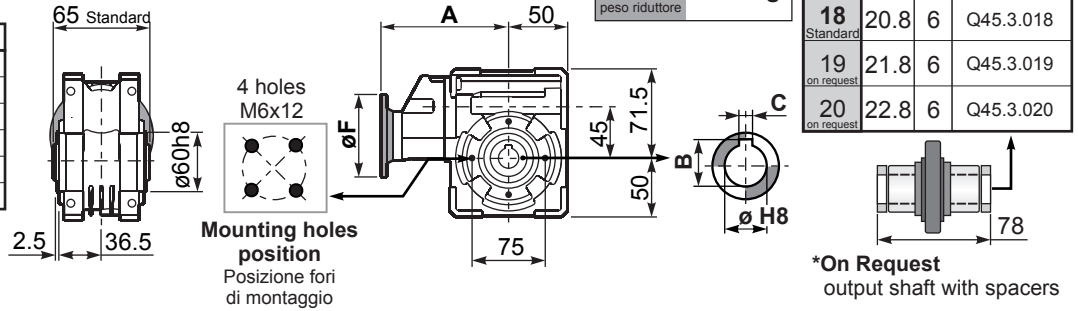

**PP4QFC...** Square flange  
Flangia quadrata

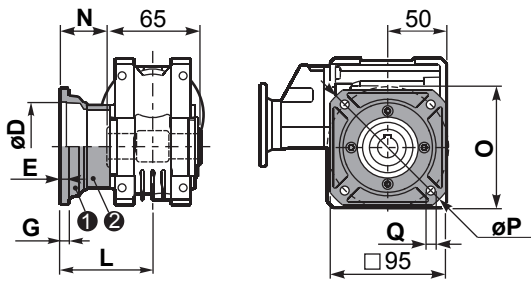

type B	øD	E	G	L	N	O	P	Q	kit code
<b>FC</b>	60 H8	4	7	67	34.5	75	110	9	KQ45.9.010
<b>FL</b>	60 H8	4	7	97	64.5	75	110	9	KQ45.9.011

**PP4QF1...** Round flange  
Flangia rotonda

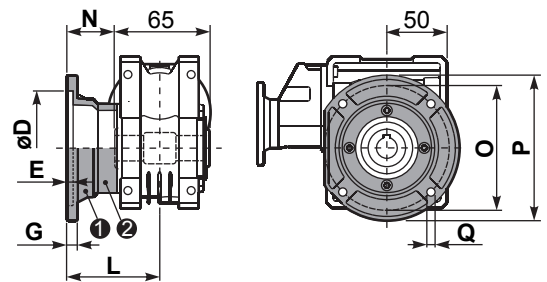

type S	øD	E	G	L	N	O	P	Q	kit code
<b>F1</b>	95H8	5	9	80	47.5	115	140	9.5	KSQ45.9.012
<b>F2</b>	80H8	5	12	58	25.5	100	120	9	KSQ45.9.013

**PP4QFB...** Feet  
Piedini

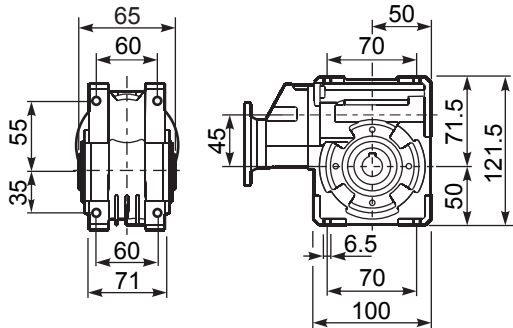

**PP4QBR...** Reaction arm  
Braccio di reazione

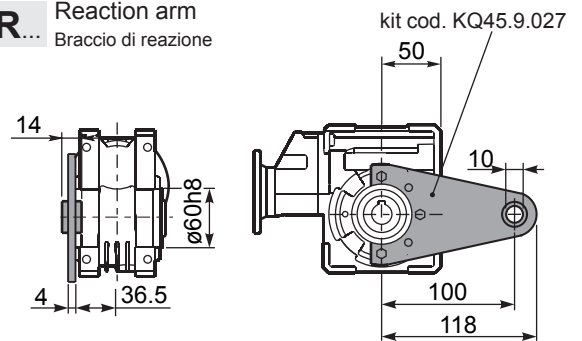

**RP4QFB...** Input shaft  
Albero in entrata

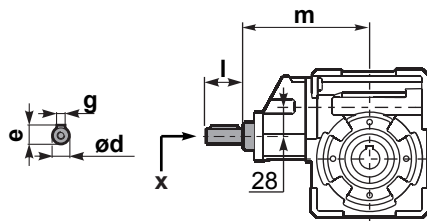

	ød	e	g	l	m	x	
type B	14 h6	16	5	25	141	M5x13	C35.5.061
type S	-	-	-	-	-	-	

**PP4Q.....S...** Single Shaft  
Albero lento semplice

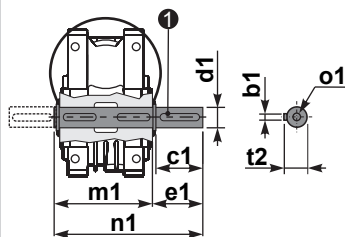

① kit cod. K045.5.028 type B  
kit cod. KS045.5.030 type S

**PP4Q.....D...** Double Shaft  
Albero lento bisp.

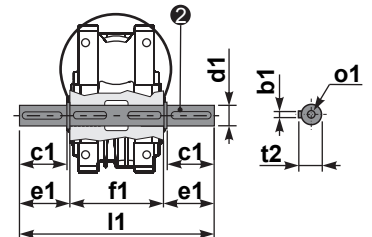

② kit cod. K045.5.029 type B  
kit cod. KS045.5.031 type S

	b1	c1	d1	e1	f1	l1	m1	n1	t2	o1
type B	6	32	18 <sup>-0.005</sup> -0.020	43	65	151	70	113	20.5	M6x18
type S	6	40	19 <sup>-0.005</sup> -0.020	58.5	65	182	70	128.5	21.5	M8x20

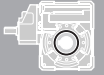

### QUICK SELECTION / Selezione veloce

input speed ( $n_1$ ) = 1400 min<sup>-1</sup>

Output Speed $n_2$ [min <sup>-1</sup> ]	Ratio $i$	Motor power $P_{1M}$ [kW]	Output torque $M_{2M}$ [Nm]	Service factor f.s.	Nominal power $P_{1R}$ [kW]	Nominal torque $M_{2R}$ [Nm]	Available B5 motor flanges			Available B14 motor flanges		Dynamic efficiency <b>RD</b>	Tooth Module  [mm]	Ratios code 
							-A	-B	-C	-P	-Q			
							56	63	71	63	71			
47	<b>30.1</b>	0.37	58	1.3	<b>0.49</b>	77				C		76	2.5	01
33	<b>43.0</b>	0.25	55	1.4	<b>0.35</b>	77				C		75	2.4	02
23	<b>60.2</b>	0.25	71	1.1	<b>0.27</b>	77				C		69	2.6	03
18.1	<b>77.4</b>	0.25	81	1.1	<b>0.27</b>	88				C		61	2.0	04
12.5	<b>112</b>	0.18	84	1.1	<b>0.19</b>	88				C		61	2.7	05
9.0	<b>155</b>	0.12	71	1.2	<b>0.15</b>	88				C		56	2.1	06
7.6	<b>185</b>	0.12	74	1.0	<b>0.12</b>	77				C		49	1.8	07
5.4	<b>258</b>	0.12*	77	<0.8	<b>0.09</b>	77				C		47	1.3	08
4.8	<b>292</b>	0.12*	66	<0.8	<b>0.08</b>	66				C		44	1.2	09
4.1	<b>344</b>	0.12*	44	<0.8	<b>0.05</b>	44				C		40	1.0	10
3.3	<b>430</b>	0.12*	44	<0.8	<b>0.04</b>	44				C		36	0.8	11

**A) Motor Flanges Available**  
Flange Motore Disponibili

**B) Supplied with Reduction Bushing**  
Fornito con Bussola di Riduzione

**B) Available on Request without reduction bushing**  
Disponibile a Richiesta senza Bussola di Riduzione

**C) Motor Flange Holes Position**  
Posizione Fori Flangia Motore

\* Power higher than the maximum one which can be supported by the gearbox. Select according to the torque  $M_{2R}$   
Potenza superiore a quella massima sopportabile dal riduttore. Selezionare in base al momento torcente  $M_{2R}$

**EN** Unit **P5Q** is supplied with synthetic oil, providing "long life" lubrication. For mounting position V5-V6 please contact us. See table 1 for lubrication and recommended quantity. In table 2 please see possible radial loads and axial loads on the gearbox.

**I** Il riduttore tipo **P5Q** viene fornito lubrificato a vita con olio sintetico. Per posizioni V5-V6 contattare il ns. servizio tecnico. Vedi tab.1 per oli e quantità consigliati. In tab.2 sono presenti i carichi radiali e assiali applicabili al riduttore.

**D** Für die Lebensdauerschmierung ist das Getriebe der Größe **P5Q** mit synthetischem Öl befüllt. Bei Einbaulage V5 oder V6 bitten wir um Rücksprache. In Tabelle 1 ist die Schmiermenge und das empfohlene Schmiermittel angegeben. In Tabelle 2 sind die zulässigen Radial- und Axialbelastungen des Getriebes aufgeführt.

**F** Le réducteur de type **P5Q** est fourni lubrifié à vie avec de l'huile synthétique. Concernant les positions V5.V6, contactez notre service d'assistance technique. Voir tableau 1 concernant les huiles et les quantités conseillées. Les charges radiales et axiales applicables au réducteur sont précisées dans le tableau 2.

**E** El reductor tamaño **P5Q** se suministra, lubricado de por vida con aceite sintético. Para las posiciones V5 y V6 contactar con nuestro servicio técnico. Ver tabla 1, para cantidades y aceites recomendados. En la tabla 2, se encuentran las cargas radiales y axiales admitidas por el reductor.

**■ LUBRICATION P5Q Oil**  
Common lubrication 0.26 l ( A + B ).

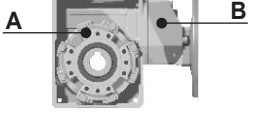

<b>AGIP</b> Telium VSF 320	<b>SHELL</b> Omala S4 WE 320
----------------------------	------------------------------

For all details on lubrication and plugs check our website **tab. 1**  
Per maggiori dettagli su lubrificazione e tappi olio vedi il nostro sito web

### ■ RADIAL AND AXIAL LOADS

**Output shaft**  
Albero di uscita

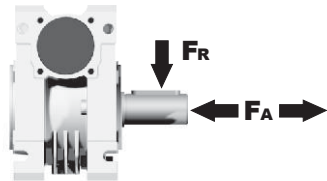

$n_2$ [min <sup>-1</sup> ]	FA [N]	FR [N]
75	340	1700
50	380	1900
25	480	2500
15-6	560	2800

**Input shaft**  
albero in entrata

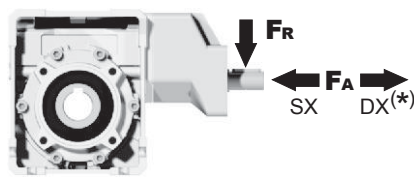

$n_1$ [min <sup>-1</sup> ]	FA [N]	FR [N]
1400	44	220

**\*Strong axial loads in the DX direction are not allowed.**  
Non sono consentiti forti carichi assiali con direzione DX

**tab. 2**

**PP5QFB...** Basic wormbox  
Riduttore base

M. flanges	Kit code	øF	A
56B5	K050.4.046	120	147
63B5	K050.4.041	138	149
71B5	K050.4.042	160	146.5
63B14	K050.4.047	90	149
71B14	K050.4.045	105	146.5

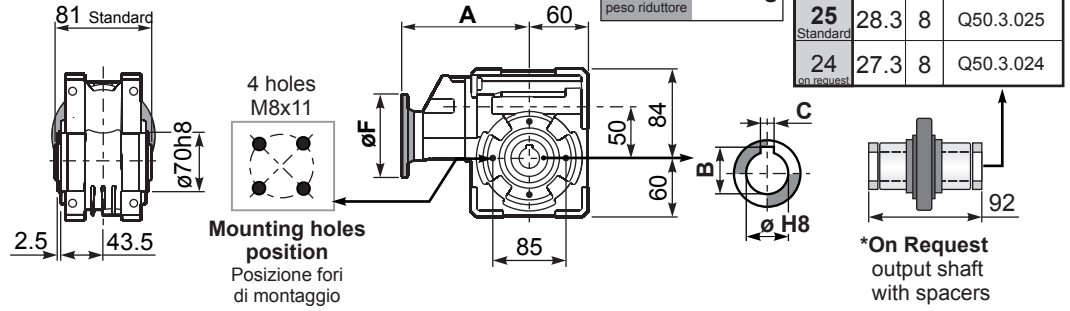

**PP5QFC...** Square flange  
Flangia quadrata

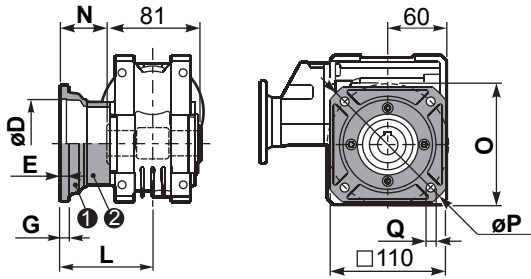

type B	øD	E	G	L	N	O	P	Q	kit code
FC	70 H8	5	9	90	49.5	85	125	11	KQ50.9.010
FL	70 H8	5	9	120	79.5	85	125	11	KQ50.9.011

**PP5QF1...** Round flange  
Flangia rotonda

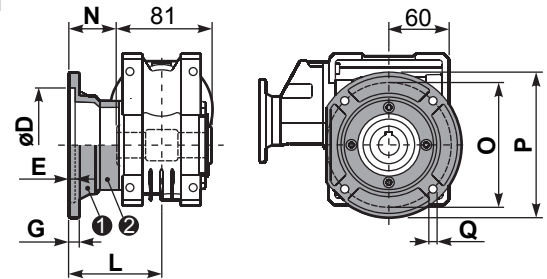

type S	øD	E	G	L	N	O	P	Q	kit code
F1	110 H8	5	10	89	69.5	130	160	9.5	KSQ50.9.012
F2	95 H8	5	14.5	72	31.5	115	140	11	KSQ50.9.013

**PP5QFB...** Feet  
Piedini

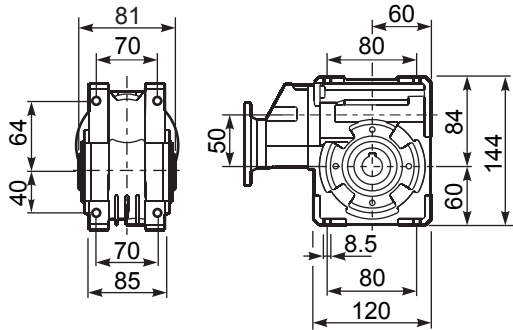

**PP5QBR...** Reaction arm  
Braccio di reazione

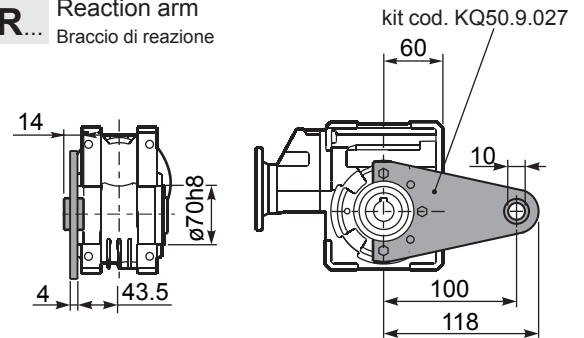

**RP5QFB...** Input shaft  
Albero in entrata

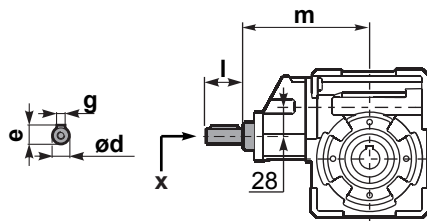

	ød	e	g	l	m	x	
type B	14 h6	16	5	25	140.5	M5x13	C35.5.061
type S	-	-	-	-	-	-	

**PP5Q.....S...** Single Shaft  
Albero lento semplice

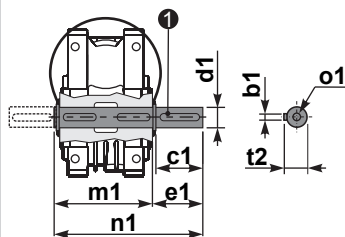

① kit cod. K050.5.028 type B  
kit cod. KS050.5.030 type S

**PP5Q.....D...** Double Shaft  
Albero lento bisp.

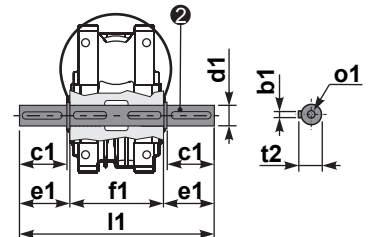

② kit cod. K050.5.029 type B  
kit cod. KS050.5.031 type S

	b1	c1	d1	e1	f1	l1	m1	n1	t2	o1
type B	8	52	25 <sup>-0.005</sup> <sub>-0.020</sub>	59.5	81	200	86.5	146	28	M8x20
type S	8	50	24 <sup>-0.005</sup> <sub>-0.020</sub>	68.8	81	218	86.5	155	27	M8x20

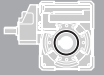

### QUICK SELECTION / Selezione veloce

input speed ( $n_1$ ) = 1400 min<sup>-1</sup>

	Output Speed $n_2$ [min <sup>-1</sup> ]	Ratio $i$	Motor power $P_{1M}$ [kW]	Output torque $M_{2M}$ [Nm]	Service factor f.s.	Nominal power $P_{1R}$ [kW]	Nominal torque $M_{2R}$ [Nm]	Available B5 motor flanges				Available B14 motor flanges				Dynamic efficiency <b>RD</b>	Tooth Module [mm]	Ratios code 
								-B	-C	-D	-E	-P	-Q	-R	-T			
								63	71	80	90	63	71	80	90			
IEC 90 - 71	47	<b>29.9</b>	0.75	113	1.5	<b>1.1</b>	<b>165</b>						C	C		74	2.6	01
	37	<b>37.7</b>	0.75	141	1.2	<b>0.88</b>	<b>165</b>						C	C		73	2.0	02
	30	<b>47.1</b>	0.75	169	1.1	<b>0.83</b>	<b>187</b>						C	C		70	3.2	03
	25	<b>56.6</b>	0.55	136	1.4	<b>0.76</b>	<b>187</b>						C	C		64	2.7	04
	19.8	<b>70.7</b>	0.55	164	1.1	<b>0.63</b>	<b>187</b>						C	C		62	2.1	05
	15.9	<b>87.8</b>	0.37	162	1.2	<b>0.43</b>	<b>187</b>						C	C		73	2.6	06
	12.6	<b>111.0</b>	0.37	199	0.9	<b>0.35</b>	<b>187</b>						C	C		71	2.0	07
IEC 71 - 63	10.1	<b>139</b>	0.37	234	0.8	<b>0.30</b>	<b>187</b>						C			67	3.2	08
	8.4	<b>166</b>	0.25	173	1.1	<b>0.27</b>	<b>187</b>						C			61	2.7	09
	6.7	<b>208</b>	0.18	151	1.1	<b>0.20</b>	<b>165</b>						C			59	2.1	10
	4.5	<b>310</b>	0.12	129	1.3	<b>0.15</b>	<b>165</b>						C			51	1.5	11
	3.8	<b>370</b>	0.12	145	1.1	<b>0.14</b>	<b>165</b>						C			48	1.3	12
	3.2	<b>434</b>	0.12	149	0.9	<b>0.11</b>	<b>138</b>						C			42	1.1	13

**A) Motor Flanges Available**  
Flange Motore Disponibili

**B) Supplied with Reduction Bushing**  
Fornito con Bussola di Riduzione

**B) Available on Request without reduction bushing**  
Disponibile a Richiesta senza Bussola di Riduzione

**C) Motor Flange Holes Position**  
Posizione Fori Flangia Motore

**EN** Unit **P6Q** is supplied with synthetic oil, providing "long life" lubrication. For mounting position V5-V6 please contact us. See table 1 for lubrication and recommended quantity. In table 2 please see possible radial loads and axial loads on the gearbox.

**I** Il riduttore tipo **P6Q** viene fornito lubrificato a vita con olio sintetico. Per posizioni V5-V6 contattare il ns. servizio tecnico. Vedi tab.1 per oli e quantità consigliati. In tab.2 sono presenti i carichi radiali e assiali applicabili al riduttore.

**D** Für die Lebensdauerschmierung ist das Getriebe der Größe **P6Q** mit synthetischem Öl befüllt. Bei Einbaulage V5 oder V6 bitten wir um Rücksprache. In Tabelle 1 ist die Schmiermenge und das empfohlene Schmiermittel angegeben. In Tabelle 2 sind die zulässigen Radial- und Axialbelastungen des Getriebes aufgeführt.

**F** Le réducteur de type **P6Q** est fourni lubrifié à vie avec de l'huile synthétique. Concernant les positions V5.V6, contactez notre service d'assistance technique. Voir tableau 1 concernant les huiles et les quantités conseillées. Les charges radiales et axiales applicables au réducteur sont précisées dans le tableau 2.

**E** El reductor tamaño **P6Q** se suministra, lubricado de por vida con aceite sintético. Para las posiciones V5 y V6 contactar con nuestro servicio técnico. Ver tabla 1, para cantidades y aceites recomendados. En la tabla 2, se encuentran las cargas radiales y axiales admitidas por el reductor.

### LUBRICATION P6Q Oil

For B3-V5-V6 separate lubrication for **A (0.30 l)** **B (0.08 l)**, for B6-B7-B8 common lubrication **0.35 l (A + B)**.

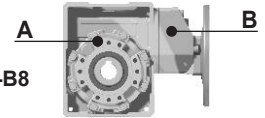

**AGIP** Telium VSF 320

**SHELL** Omala S4 WE 320

For all details on lubrication and plugs check our website

tab. 1

Per maggiori dettagli su lubrificazione e tappi olio vedi il nostro sito web

### RADIAL AND AXIAL LOADS

#### Output shaft

Albero di uscita

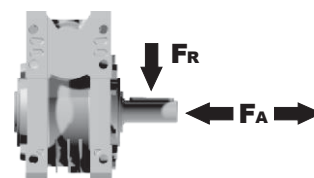

$n_2$ [min <sup>-1</sup> ]	$F_A$ [N]	$F_R$ [N]
<b>75</b>	500	2500
<b>50</b>	600	3000
<b>25</b>	700	3800
<b>15-6</b>	800	4000

#### Input shaft

albero in entrata

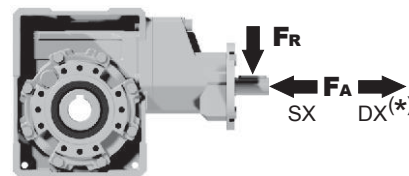

$n_1$ [min <sup>-1</sup> ]	$F_A$ [N]	$F_R$ [N]
<b>1400</b>	61	305

\*Strong axial loads in the DX direction are not allowed.  
Non sono consentiti forti carichi assiali con direzione DX

tab. 2

**PP6QFB...** Basic wormbox  
Riduttore base

Gearbox weight	29.9+111	139+434
peso riduttore	7.05	6.60
	Kg	Kg

M.flange	Kit code	øF	A
71B5	K063.4.042	160	176.5
80/90B5	K063.4.043	200	178.5
71B14	K063.4.047	105	176.5
80B14	K063.4.046	120	178.5
90B14	K063.4.041	140	178.5
<hr/>			
63B5	K050.4.041	138	162.5
71B5	K050.4.042	160	160
63B14	K050.4.047	90	162.5
71B14	K050.4.045	105	160

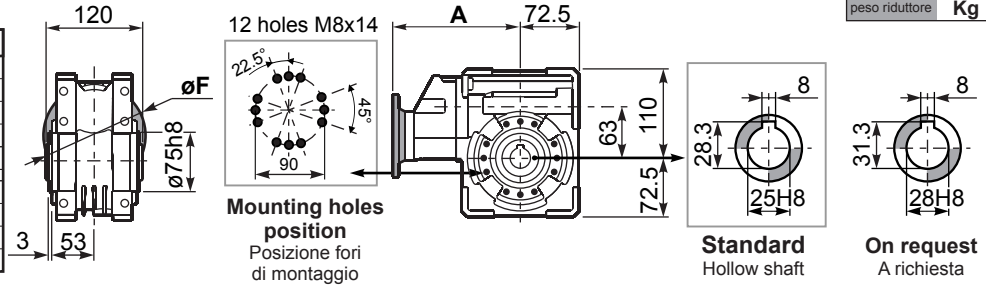

**PP6QFC...** Output flange  
Flangia uscita

**PP6QF1...** Output flange  
Flangia uscita

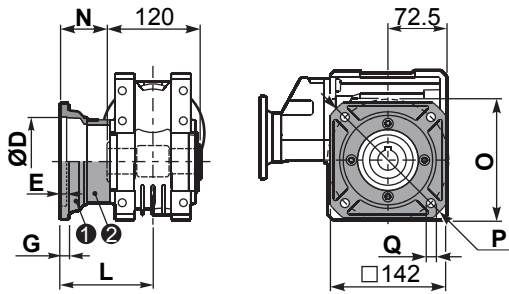

type B	øD	E	G	L	N	O	P	Q	kit code
FC	115 <sup>+0.20</sup> / <sub>+0.15</sub>	6	12	86	26	150	180	11	1 KQ63.9.010 2 -
FL	115 <sup>+0.20</sup> / <sub>+0.15</sub>	6	12	116	56	150	180	11	1 KQ63.9.010 2 K063.0.200

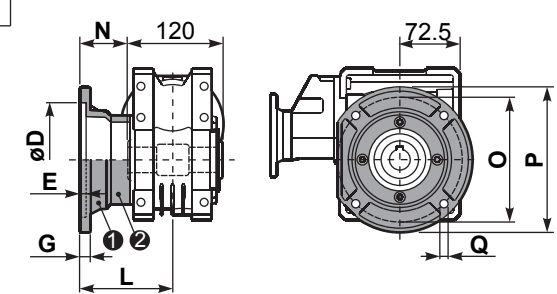

type S	øD	E	G	L	N	O	P	Q	kit code
F1	130 <sup>+0.20</sup> / <sub>+0.15</sub>	7	13	110	50	165	200	13	1 KS070.9.013 2 -
F2	115 <sup>+0.20</sup> / <sub>+0.15</sub>	7	13	124	64	150	175	11	1 KS063.9.013 2 -
F3	110 <sup>+0.035</sup> / <sub>0</sub>	5	11	90	30	130	160	10	1 KS063.9.011 2 -

**PP6QFB...** Feet  
Piedini

**PP6QBR...** Reaction arm  
Braccio di reazione

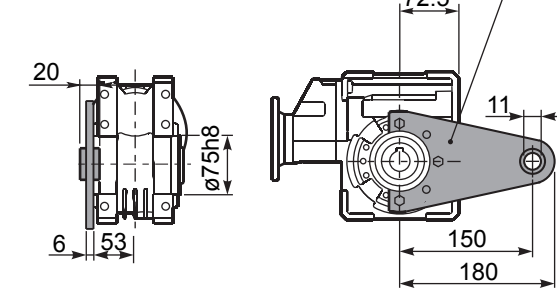
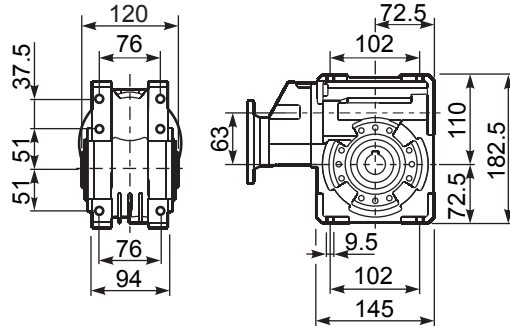

**RP6QFB...** Input shaft  
Albero in entrata

**PP6Q.....S...** Single Shaft  
Albero lento semplice

**PP6Q.....D...** Double Shaft  
Albero lento bisp.

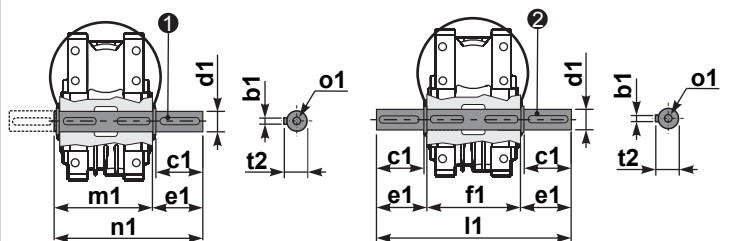
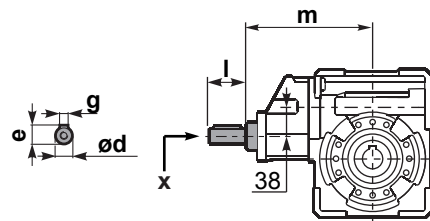

1 kit cod. K063.5.028 type B    2 kit cod. K063.5.029 type B

	ød	e	g	l	m	x	
29.9+111	19 h6	21.5	6	35	169.4	M6x16	C40.5.062
139+434	14 h6	16	5	25	154.2	M5x13	C35.5.061

	b1	c1	d1	e1	f1	l1	m1	n1	t2	o1
type B	8	60	25 <sup>-0.005</sup> / <sub>-0.020</sub>	63.2	120	246.4	126.8	190	28	M8x20
type S	-	-	-	-	-	-	-	-	-	-

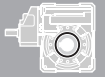

### QUICK SELECTION / Selezione veloce

input speed (n<sub>1</sub>) = 1400 min<sup>-1</sup>

Output Speed n <sub>2</sub> [min <sup>-1</sup> ]	Ratio i	Motor power P <sub>1M</sub> [kW]	Output torque M <sub>2M</sub> [Nm]	Service factor f.s.	Nominal power P <sub>1R</sub> [kW]	Nominal torque M <sub>2R</sub> [Nm]	Available B5 motor flanges				Available B14 motor flanges			Dynamic efficiency RD	Tooth Module [mm]	Ratios code
							-B	-C	-D	-E	-Q	-R	-T			
							63	71	80	90	71	80	90			
22	<b>62.9</b>	0.75	248	1.2	<b>0.87</b>	<b>286</b>					C	C		77	3.10	01
18	<b>78.5</b>	0.75	293	1.0	<b>0.73</b>	<b>286</b>					C	C		73	2.41	02
15	<b>94.2</b>	0.75	333	0.9	<b>0.70</b>	<b>310</b>					C	C		69	2.10	03
11	<b>126</b>	0.55	297	1.0	<b>0.55</b>	<b>296</b>	B				C	C		63	1.53	04
9	<b>157</b>	0.37	230	1.1	<b>0.41</b>	<b>252</b>	B				C	C		58	1.23	05
8	<b>185</b>	0.37	257	1.2	<b>0.43</b>	<b>296</b>	B				C	C		55	3.10	06
6	<b>231</b>	0.25	193	1.5	<b>0.38</b>	<b>296</b>	B				C	C		49	2.41	07
5	<b>277</b>	0.25	222	1.3	<b>0.33</b>	<b>296</b>	B				C	C		47	2.10	08
4	<b>378</b>	0.18	200	1.5	<b>0.27</b>	<b>296</b>	B				C	C		43	2.10	09

**A** Motor Flanges Available  
Flange Motore Disponibili

**B** Supplied with Reduction Bushing  
Fornito con Bussola di Riduzione

**B** Available on Request without reduction bushing  
Disponibile a Richiesta senza Bussola di Riduzione

**C** Motor Flange Holes Position  
Posizione Fori Flangia Motore

\* Power higher than the maximum one which can be supported by the gearbox. Select according to the torque M<sub>2R</sub>  
Potenza superiore a quella massima sopportabile dal riduttore. Selezionare in base al momento torcente M<sub>2R</sub>

**EN** Unit P7Q is supplied with synthetic oil, providing "long life" lubrication. For mounting position V5-V6 please contact us. See table 1 for lubrication and recommended quantity. In table 2 please see possible radial loads and axial loads on the gearbox.

**I** Il riduttore tipo P7Q viene fornito lubrificato a vita con olio sintetico. Per posizioni V5-V6 contattare il ns. servizio tecnico. Vedi tab.1 per oli e quantità consigliati. In tab.2 sono presenti i carichi radiali e assiali applicabili al riduttore.

**D** Für die Lebensdauerschmierung ist das Getriebe der Größe P7Q mit synthetischem Öl befüllt. Bei Einbaulage V5 oder V6 bitten wir um Rücksprache. In Tabelle 1 ist die Schmiermenge und das empfohlene Schmiermittel angegeben. In Tabelle 2 sind die zulässigen Radial- und Axialbelastungen des Getriebes aufgeführt.

**F** Le réducteur de type P7Q est fourni lubrifié à vie avec de l'huile synthétique. Concernant les positions V5.V6, contactez notre service d'assistance technique. Voir tableau 1 concernant les huiles et les quantités conseillées. Les charges radiales et axiales applicables au réducteur sont précisées dans le tableau 2.

**E** El reductor tamaño P7Q se suministra, lubricado de por vida con aceite sintético. Para las posiciones V5 y V6 contactar con nuestro servicio técnico. Ver tabla 1, para cantidades y aceites recomendados. En la tabla 2, se encuentran las cargas radiales y axiales admitidas por el reductor.

### LUBRICATION P7Q Oil

For B3-V5-V6 separate lubrication for A (0.40 l) B (0.14 l), for B6-B7-B8 common lubrication 0.65 l (A + B).

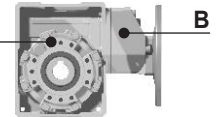

AGIP Telium VSF 320

SHELL Omala S4 WE 320

For all details on lubrication and plugs check our website **tab. 1**  
Per maggiori dettagli su lubrificazione e tappi olio vedi il nostro sito web

### RADIAL AND AXIAL LOADS

#### Output shaft

Albero di uscita

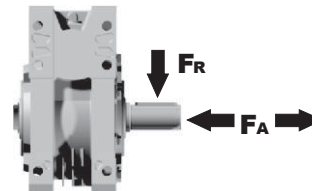

n <sub>2</sub> [min <sup>-1</sup> ]	FA [N]	FR [N]
75	620	3100
50	720	3600
25	880	4400
15-6	1000	5000

#### Input shaft

albero in entrata

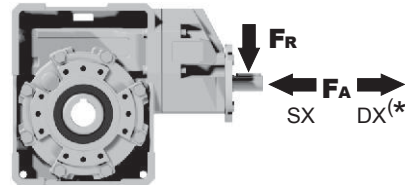

n [min <sup>-1</sup> ]	FA [N]	FR [N]
1400	108	540

\*Strong axial loads in the DX direction are not allowed.  
Non sono consentiti forti carichi assiali con direzione DX

tab. 2



PP7Q**FB**... Basic wormbox  
Riduttore base

Gearbox weight  
peso riduttore **9.90 kg**

M. flanges	Kit code	øF	A
63B5	K063.4.041	140	192.7
71B5	K063.4.042	160	190.7
80/90B5	K063.4.043	200	192.7
71B14	K063.4.047	105	190.7
80B14	K063.4.046	120	192.7
90B14	K063.4.041	140	192.7

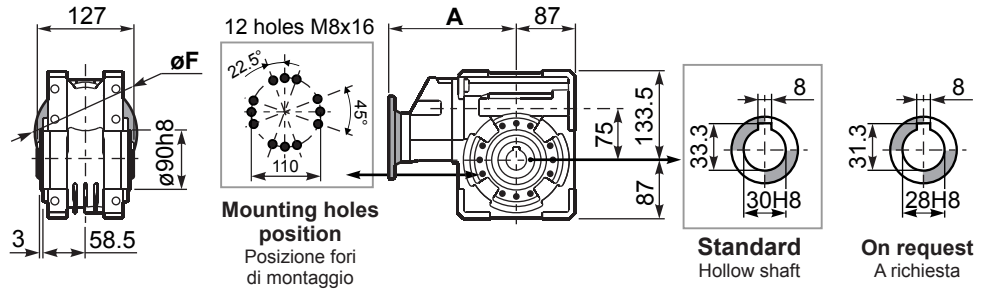

PP7Q**FC**... Square flange  
Flangia quadrata

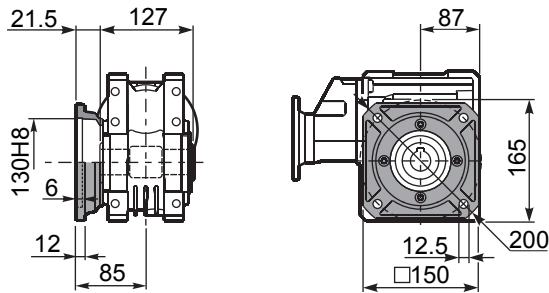

PP7Q**FL**... Square flange  
Flangia quadrata

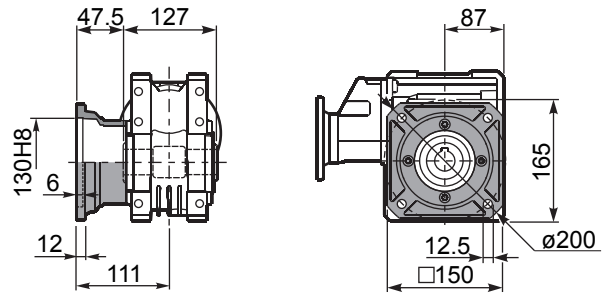

PP7Q**FB**... Feet  
Piedini

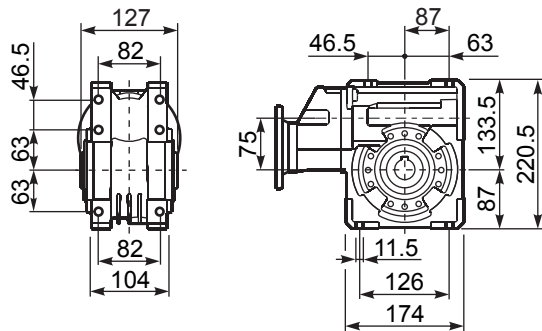

PP7Q**BR**... Reaction arm  
Braccio di reazione

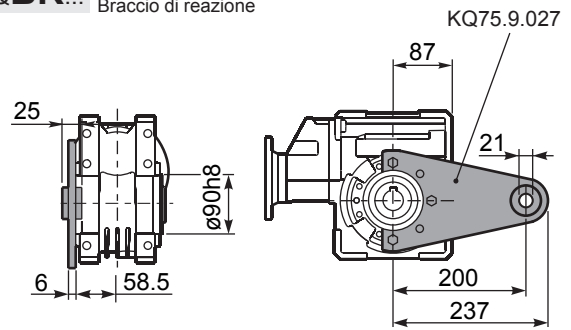

RP7Q**FB**... Input shaft  
Albero in entrata

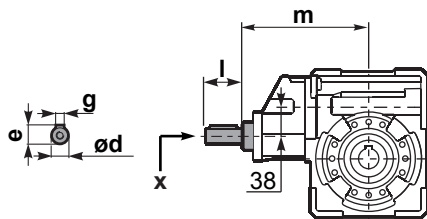

PP7Q.....**S**... Single Shaft  
Albero lento semplice

PP7Q.....**D**... Double Shaft  
Albero lento bisp.

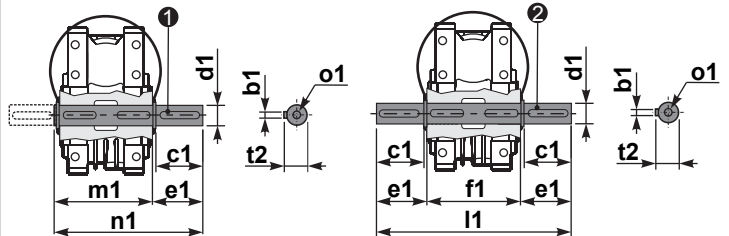

① kit cod. KQ75.5.028 Standard  
kit cod. KQ75.5.026 On request

② kit cod. KQ75.5.029 Standard  
kit cod. KQ75.5.027 On request

	ød	e	g	l	m	x	
type B	19 h6	21.5	6	35	185.5	M6x16	C40.5.062
type S	-	-	-	-	-	-	

	b1	c1	d1	e1	f1	l1	m1	n1	t2	o1
Standard	8	60	30 <sup>-0.005</sup> <sub>-0.020</sub>	65	127	255	134	199	33	M8x20
On request	8	50	28 <sup>-0.005</sup> <sub>-0.020</sub>	65	127	255	134	199	31	M8x20

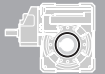

#### QUICK SELECTION / Selezione veloce

input speed ( $n_1$ ) = 1400 min<sup>-1</sup>

Output Speed $n_2$ [min <sup>-1</sup> ]	Ratio $i$	Motor power $P_{1M}$ [kW]	Output torque $M_{2M}$ [Nm]	Service factor f.s.	Nominal power $P_{1R}$ [kW]	Nominal torque $M_{2R}$ [Nm]	Available B5 motor flanges				Available B14 motor flanges			Dynamic efficiency <b>RD</b>	Tooth Module [mm]	Ratios code
							-B	-C	-D	-E	-Q	-R	-T			
							63	71	80	90	71	80	90			
23.5	<b>59.7</b>	1.1	300	1.4	<b>1.5</b>	<b>418</b>					<b>C</b>	<b>C</b>		67	3.5	01
19.4	<b>72.3</b>	1.1	347	1.2	<b>1.3</b>	<b>407</b>					<b>C</b>	<b>C</b>		64	3.1	02
17.1	<b>81.7</b>	1.1	374	1.1	<b>1.2</b>	<b>418</b>					<b>C</b>	<b>C</b>		61	2.7	03
13.3	<b>105</b>	0.75	323	1.2	<b>0.89</b>	<b>385</b>					<b>C</b>	<b>C</b>		60	2.1	04
8.0	<b>176</b>	0.55	415	1.1	<b>0.58</b>	<b>440</b>	<b>B</b>				<b>C</b>	<b>C</b>		63	3.5	05
6.6	<b>213</b>	0.37	322	1.3	<b>0.47</b>	<b>407</b>	<b>B</b>				<b>C</b>	<b>C</b>		60	3.1	06
5.8	<b>240</b>	0.37	321	1.3	<b>0.48</b>	<b>418</b>	<b>B</b>				<b>C</b>	<b>C</b>		53	2.7	07
4.3	<b>328</b>	0.37	438	1.0	<b>0.35</b>	<b>418</b>	<b>B</b>				<b>C</b>	<b>C</b>		53	2.7	08
3.3	<b>422</b>	0.25	374	1.0	<b>0.26</b>	<b>385</b>	<b>B</b>				<b>C</b>	<b>C</b>		52	2.1	09
3.0	<b>466</b>	0.25	358	0.9	<b>0.23</b>	<b>330</b>	<b>B</b>				<b>C</b>	<b>C</b>		45	1.9	10
2.3	<b>605</b>	0.18	297	1.1	<b>0.20</b>	<b>330</b>	<b>B</b>				<b>C</b>	<b>C</b>		40	1.5	11

**Motor Flanges Available**  
Flange Motore Disponibili

**B) Supplied with Reduction Bushing**  
Fornito con Bussola di Riduzione

**B) Available on Request without reduction bushing**  
Disponibile a Richiesta senza Bussola di Riduzione

**C) Motor Flange Holes Position**  
Posizione Fori Flangia Motore

**EN** Unit **P8Q** is supplied with synthetic oil, providing "long life" lubrication. For mounting position V5-V6 please contact us. See table 1 for lubrication and recommended quantity. In table 2 please see possible radial loads and axial loads on the gearbox.

**I** Il riduttore tipo **P8Q** viene fornito lubrificato a vita con olio sintetico. Per posizioni V5-V6 contattare il ns. servizio tecnico. Vedi tab.1 per oli e quantità consigliati. In tab.2 sono presenti i carichi radiali e assiali applicabili al riduttore.

**D** Für die Lebensdauerschmierung ist das Getriebe der Größe **P8Q** mit synthetischem Öl befüllt. Bei Einbaulage V5 oder V6 bitten wir um Rücksprache. In Tabelle 1 ist die Schmiermenge und das empfohlene Schmiermittel angegeben. In Tabelle 2 sind die zulässigen Radial- und Axialbelastungen des Getriebes aufgeführt.

**F** Le réducteur de type **P8Q** est fourni lubrifié à vie avec de l'huile synthétique. Concernant les positions V5.V6, contactez notre service d'assistance technique. Voir tableau 1 concernant les huiles et les quantités conseillées. Les charges radiales et axiales applicables au réducteur sont précisées dans le tableau 2.

**E** El reductor tamaño **P8Q** se suministra, lubricado de por vida con aceite sintético. Para las posiciones V5 y V6 contactar con nuestro servicio técnico. Ver tabla 1, para cantidades y aceites recomendados. En la tabla 2, se encuentran las cargas radiales y axiales admitidas por el reductor.

#### LUBRICATION P8Q Oil

For B3-V5-V6 separate lubrication for A ( 1.20 l ) B ( 0.14 l ) , for B6-B7-B8 common lubrication 1.00 l ( A + B ).

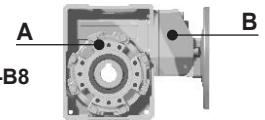

**AGIP** Telium VSF 320

**SHELL** Omala S4 WE 320

For all details on lubrication and plugs check our website **tab. 1**  
Per maggiori dettagli su lubrificazione e tappi olio vedi il nostro sito web

#### RADIAL AND AXIAL LOADS

##### Output shaft

Albero di uscita

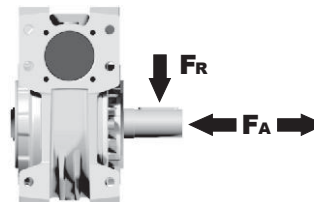

$n_2$ [min <sup>-1</sup> ]	FA [N]	FR [N]
<b>75</b>	700	3500
<b>50</b>	800	4000
<b>25</b>	1000	5000
<b>15-6</b>	1160	5800

##### Input shaft

albero in entrata

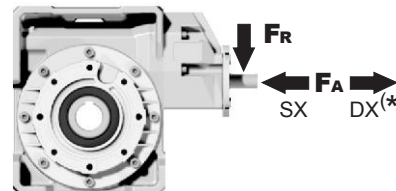

$n_1$ [min <sup>-1</sup> ]	FA [N]	FR [N]
<b>1400</b>	108	540

\*Strong axial loads in the DX direction are not allowed.  
Non sono consentiti forti carichi assiali con direzione DX

tab. 2

**PP8QFB...** Basic wormbox  
Riduttore base

Gearbox weight  
peso riduttore **12.3 kg**

M. flanges	Kit code	øF	A
63B5	K063.4.041	140	195.2
71B5	K063.4.042	160	193.2
80/90B5	K063.4.043	200	195.2
71B14	K063.4.047	105	193.2
80B14	K063.4.046	120	195.2
90B14	K063.4.041	140	195.2

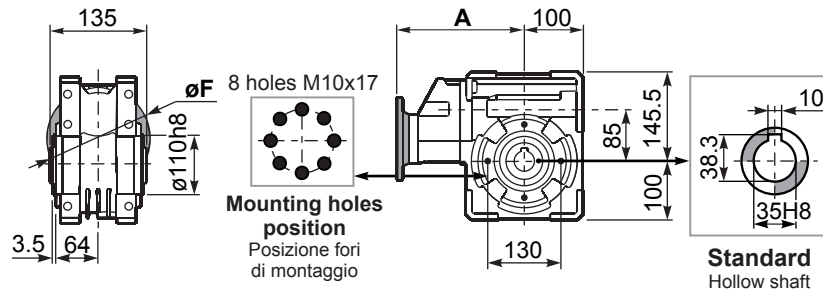

**PP8QFC...** Output flange  
Flangia uscita

**PP8QF1...** Output flange  
Flangia uscita

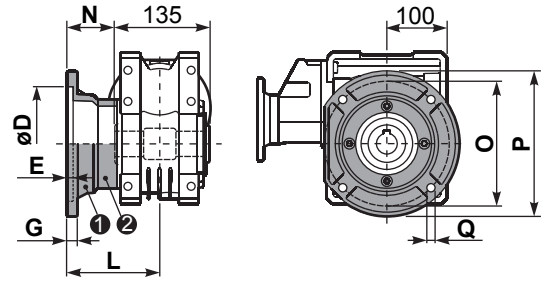
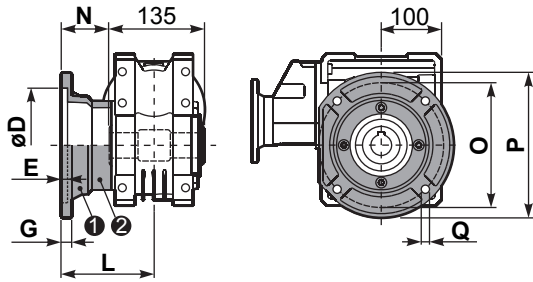

type B	øD	E	G	L	N	O	P	Q	kit code
FC	152 <sup>+0.06</sup> / <sub>+0.00</sub>	5	16	108	40.5	176	205	13	1 K085.9.010 2 -
FL	152 <sup>+0.06</sup> / <sub>+0.00</sub>	5	16	148.5	81	176	205	13	1 K085.9.010 2 K085.0.201

type S	øD	E	G	L	N	O	P	Q	kit code
F1	130 <sup>+0.04</sup> / <sub>+0.00</sub>	5	13	117.5	50	165	200	11.5	1 KS085.9.012 2 -
F2	152 <sup>+0.06</sup> / <sub>+0.00</sub>	5	15	147.5	80	180	205	12.5	1 KS085.9.013 2 -
F4	130 <sup>+0.04</sup> / <sub>+0.00</sub>	5	13	106.5	39	165	200	13	1 KS085.9.015 2 -

**PP8QFB...** Feet  
Piedini

**PP8QBR...** Reaction arm  
Braccio di reazione

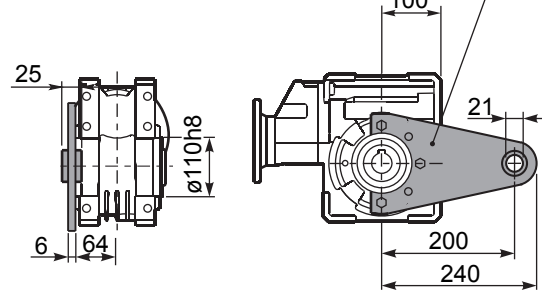
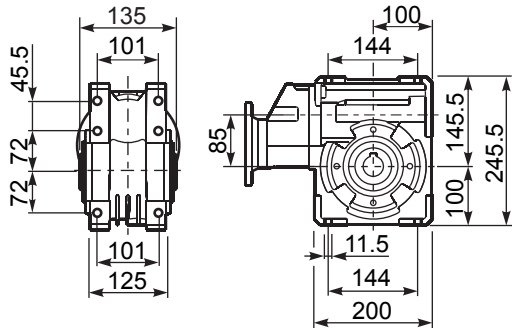

**RP8QFB...** Input shaft  
Albero in entrata

**PP8Q.....S...** Single Shaft  
Albero lento semplice

**PP8Q.....D...** Double Shaft  
Albero lento bisp.

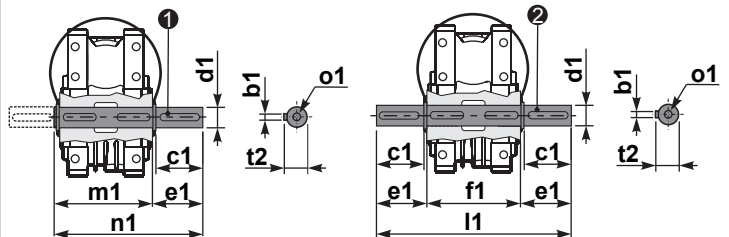
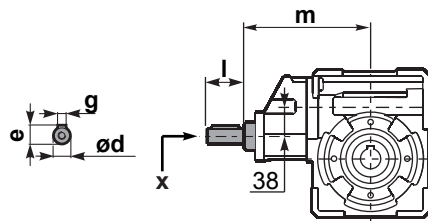

1 kit cod. K085.5.028 type B    2 kit cod. K085.5.029 type B

	ød	e	g	l	m	x	
type B	19 h6	21.5	6	35	187.5	M6x16	C40.5.062
type S	-	-	-	-	-	-	-

	b1	c1	d1	e1	f1	l1	m1	n1	t2	o1
type B	10	60	35 <sup>-0.005</sup> / <sub>-0.020</sub>	73.5	135	282	141	214.5	38	M10x23
type S	-	-	-	-	-	-	-	-	-	-

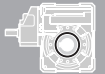

### QUICK SELECTION / Selezione veloce

input speed ( $n_1$ ) = 1400 min<sup>-1</sup>

Output Speed $n_2$ [min <sup>-1</sup> ]	Ratio $i$	Motor power $P_{1M}$ [kW]	Output torque $M_{2M}$ [Nm]	Service factor f.s.	Nominal power $P_{1R}$ [kW]	Nominal torque $M_{2R}$ [Nm]	Available B5 motor flanges				Available B14 motor flanges			Dynamic efficiency <b>RD</b>	Tooth Module  [mm]	Ratios code 
							-B	-C	-D	-E	-Q	-R	-T			
							63	71	80	90	71	80	90			
16.8	<b>83.2</b>	1.5	587	1.1	<b>1.7</b>	<b>660</b>					C			69	3.5	01
13.9	<b>100.5</b>	1.5	699	0.8	<b>1.3</b>	<b>594</b>					C			68	2.9	02
10.6	<b>132</b>	1.1	634	0.9	<b>0.95</b>	<b>550</b>					C			64	2.2	03
8.0	<b>176</b>	0.75	666	1.2	<b>0.90</b>	<b>803</b>	B				C			74	4.7	04
6.7	<b>208</b>	0.75	766	0.9	<b>0.65</b>	<b>660</b>	B				C			72	4.0	05
5.7	<b>245</b>	0.55	634	1.0	<b>0.57</b>	<b>660</b>	B				C			69	3.5	06
4.7	<b>296</b>	0.55	755	0.8	<b>0.43</b>	<b>594</b>	B				C			68	2.9	07
4.2	<b>334</b>	0.55	865	0.8	<b>0.42</b>	<b>660</b>	B				C			69	3.5	08
3.5	<b>403</b>	0.37	692	0.9	<b>0.32</b>	<b>594</b>	B				C			68	2.9	09
2.6	<b>529</b>	0.25	577	1.0	<b>0.24</b>	<b>550</b>	B				C			64	2.2	10
2.2	<b>624</b>	0.25	628	0.8	<b>0.21</b>	<b>528</b>	B				C			59	1.9	11

**Motor Flanges Available**  
Flange Motore Disponibili

**B) Supplied with Reduction Bushing**  
Fornito con Bussola di Riduzione

**B) Available on Request without reduction bushing**  
Disponibile a Richiesta senza Bussola di Riduzione

**C) Motor Flange Holes Position**  
Posizione Fori Flangia Motore

**EN** Unit **P1Q** is supplied without lubricant and equipped with a breather, level and drain plugs. User can add mineral oil keeping existing plugs. Should the user wish to fill it with synthetic oil, it is recommended to replace the existing plugs with a closed plug. Primary reduction unit is supplied with closed plugs and lubricated for life with synthetic oil. See table 1 for lubrication and recommended quantity. In table 2 please see possible radial loads and axial loads on the gearbox.

**I** Il riduttore tipo **P1Q** è fornito privo di lubrificazione con tappi di sfiato, livello e scarico olio. L'utente può immettere olio minerale mantenendo i tappi esistenti. Se immetterà olio sintetico, dovrà sostituire i tappi esistenti con altri tipo chiuso. La precoppia è fornita con tappi chiusi e lubrificata a vita con olio sintetico. Tab.1 per oli e quantità consigliati. Tab.2 carichi radiali e assiali applicabili al riduttore.

**D** Das Getriebe der Baugröße **P1Q** wird ohne Schmiermittel geliefert. Es ist jedoch mit Einfüllschraube, Überdruckventil und Ablassschraube ausgerüstet. Das benötigte mineralische Öl kann über die Einfüllschraube eingefüllt werden. Sollte synthetisches Öl bevorzugt werden, so ist sind das eingebaute Überdruckventil durch eine geschlossenen Schraube zu ersetzen. Die Stirnradvorstufe ist Lebensdauer geschmiert und wird mit synthetischem Öl geliefert. Die Stirnradvorstufe ist komplett geschlossen ohne Füllschrauben. In Tabelle 1 ist die Schmiermenge und das empfohlene Schmiermittel angegeben. In Tabelle 2 sind die zulässigen Radial- und Axialbelastungen des Getriebes aufgeführt.

**F** Le réducteur de type **P1Q** est fourni sans lubrification et avec un bouchon de remplissage, de niveau et d'évacuation de l'huile. L'utilisateur peut y verser de l'huile minérale en conservant les bouchons existants. S'il y versera de l'huile synthétique, il devra substituer les bouchons existants avec d'autres bouchons de type fermé. Le pré couple est fourni lubrifié à vie avec de l'huile synthétique et avec des bouchons fermés. Voir tableau 1 concernant les huiles et les quantités conseillées. Voir tableau 2 concernant les charges radiales et axiales applicables au réducteur.

**E** El reductor tamaño **P1Q** se suministra sin lubricante, provisto de tapones de respiración, nivel y descarga de aceite. El usuario puede utilizar aceite mineral, manteniendo los tapones existentes. Si prefiere utilizar aceite sintético deberá sustituir los tapones existentes por tapones ciegos. La prerreducción se suministra con tapones ciegos, lubricado de por vida con aceite sintético. Ver tabla 1, para cantidades y aceites recomendados. En la tabla 2, se encuentran las cargas radiales y axiales admitidas por el reductor.

<b>B3</b>	<b>B6</b>	<b>B7</b>	<b>B8</b>	<b>V5</b>	<b>V6</b>
2.0/0.14LT	1.35/0.14 LT	1.35/0.14 LT	2.0/0.14 LT	2.0/0.14 LT	2.0/0.14 LT

AGIP Blasias 460

For all details on lubrication and plugs check our website

Per maggiori dettagli su lubrificazione e tappi olio vedi il nostro sito web

tab. 1

### RADIAL AND AXIAL LOADS

#### Output shaft

Albero di uscita

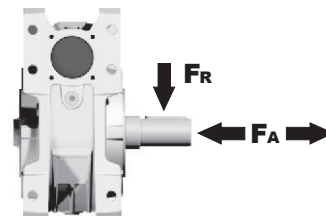

$n_2$ [min <sup>-1</sup> ]	FA [N]	FR [N]
<b>75</b>	800	4000
<b>50</b>	920	4600
<b>25</b>	1200	6000
<b>15-6</b>	1400	7000

#### Input shaft

albero in entrata

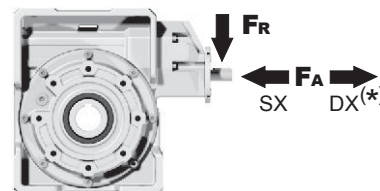

$n_1$ [min <sup>-1</sup> ]	FA [N]	FR [N]
<b>1400</b>	150	760

**\*Strong axial loads in the DX direction are not allowed.**  
Non sono consentiti forti carichi assiali con direzione DX

tab. 2

PP1Q**FB**... Basic wormbox  
Riduttore base

Gearbox weight  
peso riduttore **37.3 kg**

M. flanges	Kit code	øF	A
63B5	K063.4.041	140	214.7
71B5	K063.4.042	160	212.7
80/90B5	K063.4.043	200	214.7
71B14	K063.4.047	105	212.7
80B14	K063.4.046	120	214.7
90B14	K063.4.041	140	214.7

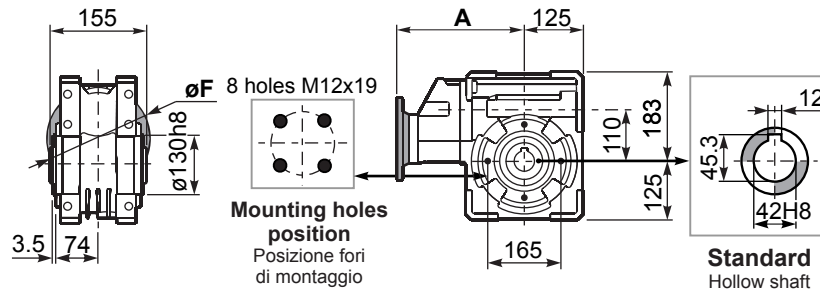

PP1Q**FC**... Output flange  
Flangia uscita

PP1Q**F1**... Output flange  
Flangia uscita

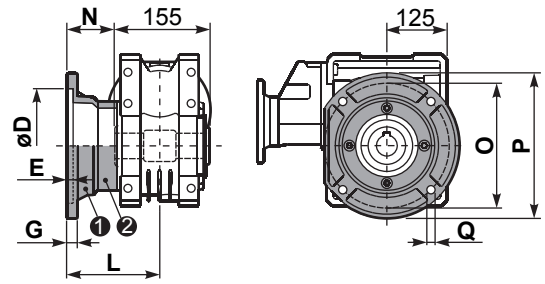
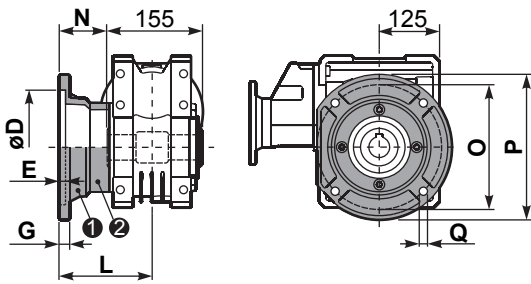

type B	øD	E	G	L	N	O	P	Q	kit code
FC	170 <sup>+0.083</sup> / <sub>+0.043</sub>	11	16.5	131.5	54	230	270	13	1 K110.9.010 2 -
FL	170 <sup>+0.083</sup> / <sub>+0.043</sub>	11	16.5	179.5	102	230	270	13	1 K110.9.011 2 -

type S	øD	E	G	L	N	O	P	Q	kit code
F1	180 <sup>+0.040</sup> / <sub>0</sub>	5	18	150	72.5	215	250	15	1 KS110.9.014 2 -
F2	170 <sup>+0.083</sup> / <sub>+0.043</sub>	9.5	15	178	100.5	230	270	13	1 KS110.9.012 2 -
F3	180 <sup>+0.040</sup> / <sub>0</sub>	5	18	130	52.5	215	250	15	1 KS110.9.013 2 -

PP1Q**FB**... Feet  
Piedini

PP1Q**BR**... Reaction arm  
Braccio di reazione

kit cod. K110.9.027

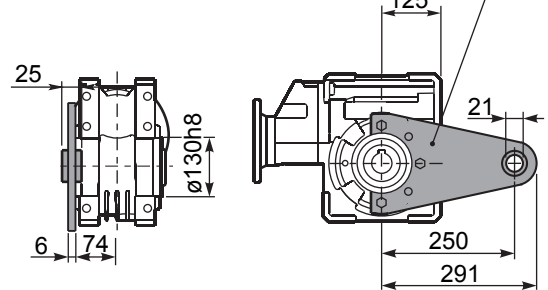
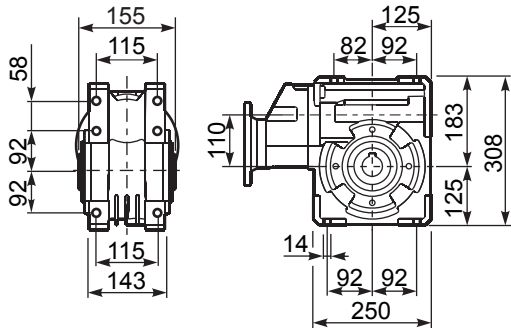

RP1Q**FB**... Input shaft  
Albero in entrata

PP1Q.....**S**... Single Shaft  
Albero lento semplice

PP1Q.....**D**... Double Shaft  
Albero lento bisp.

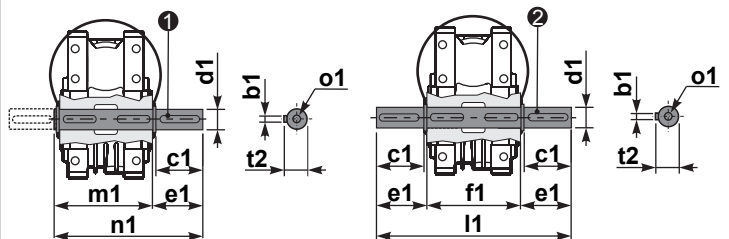
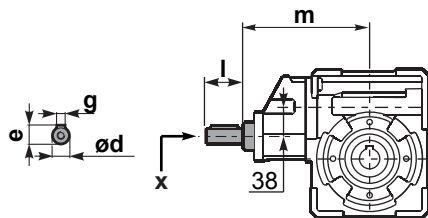

1 kit cod. K110.5.028 type B 2 kit cod. K110.5.029 type B

	ød	e	g	l	m	x	
type B	19 h6	21.5	6	35	205	M6x16	C40.5.062
type S	-	-	-	-	-	-	-

	b1	c1	d1	e1	f1	l1	m1	n1	t2	o1
type B	12	75	42 <sup>-0.005</sup> / <sub>-0.020</sub>	96.5	155	348	163.5	260	45	M12x32
type S	-	-	-	-	-	-	-	-	-	-

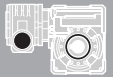

#### QUICK SELECTION / Selezione veloce

input speed ( $n_1$ ) = 1400 min<sup>-1</sup>

Output Speed $n_2$ [min <sup>-1</sup> ]	Ratio $i$	Motor power $P_{1M}$ [kW]	Output torque $M_{2M}$ [Nm]	Service factor f.s.	Nominal power $P_{1R}$ [kW]	Nominal torque $M_{2R}$ [Nm]	Available B5 motor flanges		Available B14 motor flanges		Dynamic efficiency <b>RD</b>	Tooth Module  [mm]	 Ratios code
							-A	-B	-O	-P			
							56	63	56	63			
10.0	<b>140</b>	0.12	57	1.2	<b>0.14</b>	<b>69</b>	B		B-C		50	2.2	01
7.0	<b>200</b>	0.12	79	0.9	<b>0.11</b>	<b>69</b>	B		B-C		48	2.2	02
5.0	<b>280</b>	0.12*	69	<0.8	<b>0.08</b>	<b>69</b>	B		B-C		45	2.4	03
3.3	<b>420</b>	0.12*	69	<0.8	<b>0.07</b>	<b>69</b>	B		B-C		36	1.6	04
2.5	<b>560</b>	0.12*	69	<0.8	<b>0.05</b>	<b>69</b>	B		B-C		33	2.5	05
1.9	<b>740</b>	0.12*	69	<0.8	<b>0.05</b>	<b>69</b>	B		B-C		30	1.8	06
1.5	<b>920</b>	0.12*	69	<0.8	<b>0.04</b>	<b>69</b>	B		B-C		27	1.5	07
1.3	<b>1120</b>	0.12*	69	<0.8	<b>0.03</b>	<b>69</b>	B		B-C		26	2.5	08
0.9	<b>1480</b>	0.12*	69	<0.8	<b>0.03</b>	<b>69</b>	B		B-C		24	1.8	09
0.8	<b>1840</b>	0.12*	69	<0.8	<b>0.02</b>	<b>69</b>	B		B-C		22	1.5	10
0.6	<b>2400</b>	0.12*	69	<0.8	<b>0.02</b>	<b>69</b>	B		B-C		21	1.2	11

**A) Motor Flanges Available**  
Flange Motore Disponibili

**B) Supplied with Reduction Bushing**  
Fornito con Bussola di Riduzione

**B) Available on Request without reduction bushing**  
Disponibile a Richiesta senza Bussola di Riduzione

**C) Motor Flange Holes Position**  
Posizione Fori Flangia Motore

\* Power higher than the maximum one which can be supported by the gearbox. Select according to the torque  $M_{2R}$   
Potenza superiore a quella massima sopportabile dal riduttore. Selezionare in base al momento torcente  $M_{2R}$

**EN** Unit **43Q** is supplied with synthetic oil, providing "long life" lubrication. For mounting position V5-V6 please contact us. See table 1 for lubrication and recommended quantity. In table 2 please see possible radial loads and axial loads on the gearbox.

**I** Il riduttore tipo **43Q** viene fornito lubrificato a vita con olio sintetico. Per posizioni V5-V6 contattare il ns. servizio tecnico. Vedi tab.1 per oli e quantità consigliati. In tab.2 sono presenti i carichi radiali e assiali applicabili al riduttore.

**D** Für die Lebensdauerschmierung ist das Getriebe der Größe **43Q** mit synthetischem Öl befüllt. Bei Einbaulage V5 oder V6 bitten wir um Rücksprache. In Tabelle 1 ist die Schmiermenge und das empfohlene Schmiermittel angegeben. In Tabelle 2 sind die zulässigen Radial- und Axialbelastungen des Getriebes aufgeführt.

**F** Le réducteur de type **43Q** est fourni lubrifié à vie avec de l'huile synthétique. Concernant les positions V5.V6, contactez notre service d'assistance technique. Voir tableau 1 concernant les huiles et les quantités conseillées. Les charges radiales et axiales applicables au réducteur sont précisées dans le tableau 2.

**E** El reductor tamaño **43Q** se suministra, lubricado de por vida con aceite sintético. Para las posiciones V5 y V6 contactar con nuestro servicio técnico. Ver tabla 1, para cantidades y aceites recomendados. En la tabla 2, se encuentran las cargas radiales y axiales admitidas por el reductor.

**0.09 Lt.**

**■ LUBRICATION 43Q Oil**  
**Quantity 0.09/0.03 Lt.**

**0.03 Lt.**

<b>AGIP</b> Telium VSF 320	<b>SHELL</b> Omala S4 WE 320
----------------------------	------------------------------

**For all details on lubrication and plugs check our website** **tab. 1**  
Per maggiori dettagli su lubrificazione e tappi olio vedi il nostro sito web

### ■ RADIAL AND AXIAL LOADS

**Output shaft**  
Albero di uscita

$n_2$ [min <sup>-1</sup> ]	FA [N]	FR [N]
<b>25</b>	300	1800
<b>15</b>	400	2000

**Input shaft**  
albero in entrata

$n_1$ [min <sup>-1</sup> ]	FA [N]	FR [N]
<b>1400</b>	20	100

**\*Strong axial loads in the DX direction are not allowed.**  
Non sono consentiti forti carichi assiali con direzione DX

**tab. 2**

**P43QFB...** Basic wormbox  
Riduttore base

M. flanges	Kit code	øF	A
<b>56B5</b>	K030.4.041	120	61.5
<b>63B5</b>	K030.4.042	140	62.5
<b>56B14</b>	K030.4.046	80	61.5
<b>63B14</b>	K030.4.045	90	62.5

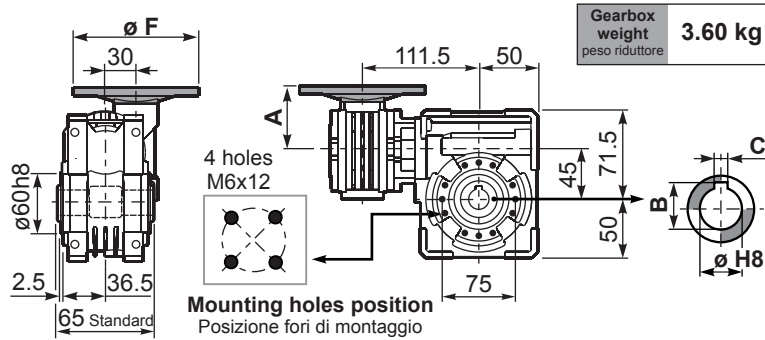

ø H8	B	C	*Spacer code
<b>18</b> Standard	20.8	6	Q45.3.018
<b>19</b> on request	21.8	6	Q45.3.019
<b>20</b> on request	22.8	6	Q45.3.020

\*On Request  
output shaft with spacers

**P43QFC...** Square flange  
Flangia quadrata

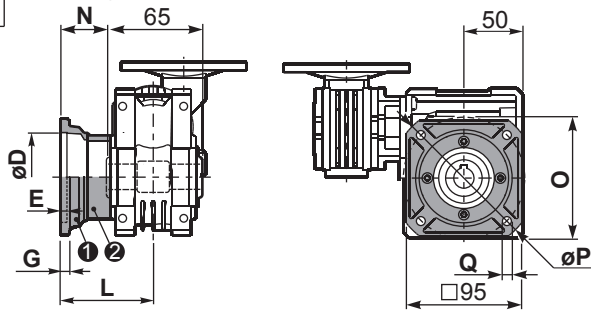

type B	øD	E	G	L	N	O	P	Q	kit code
<b>FC</b>	60 H8	4	7	67	34.5	75	110	9	KQ45.9.010
<b>FL</b>	60 H8	4	7	97	64.5	75	110	9	KQ45.9.011

**P43QF1...** Round flange  
Flangia rotonda

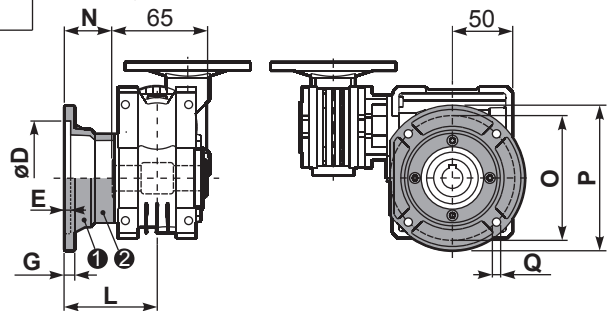

type S	øD	E	G	L	N	O	P	Q	kit code
<b>F1</b>	95H8	5	9	80	47.5	115	140	9.5	KSQ50.9.012
<b>F2</b>	80H8	5	12	58	25.5	100	120	9	KSQ50.9.013

**P43QFB...** Feet  
Piedini

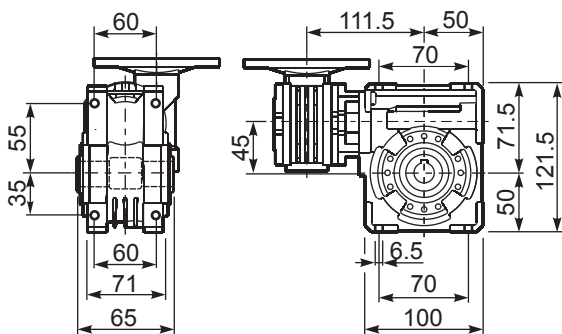

**P43QBR...** Reaction arm  
Braccio di reazione

kit cod. KQ45.9.027

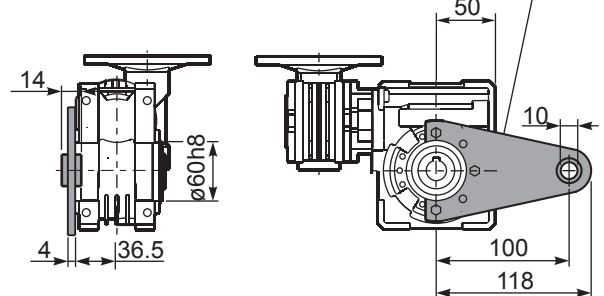

**R43QFB...** Input shaft  
Albero in entrata

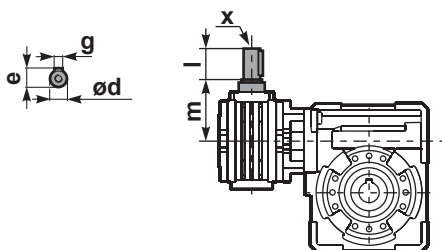

	ød	e	g	l	m	x	kit code
type B	9 h6	10.2	3	20	58	-	K030.5.006 PAM63
type S	-	-	-	-	-	-	-

**P43Q.....S...** Single Shaft  
Albero lento semplice

**P43Q.....D...** Double Shaft  
Albero lento bisp.

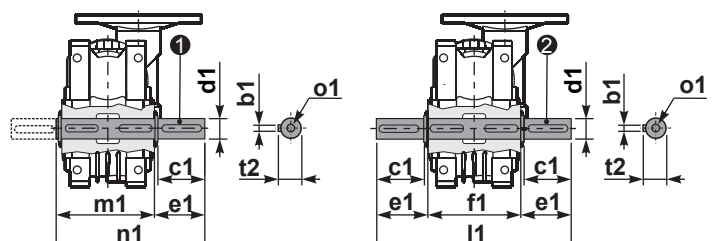

① kit cod. K045.5.028 type B  
kit cod. KS045.5.030 type S

② kit cod. K045.5.029 type B  
kit cod. KS045.5.031 type S

	b1	c1	d1	e1	f1	l1	m1	n1	t2	o1
type B	6	32	18 <sup>-0.005</sup> <sub>-0.020</sub>	43	65	151	70	113	20.5	M6x18
type S	6	40	19 <sup>-0.005</sup> <sub>-0.020</sub>	58.5	65	182	70	128.5	21.5	M8x20

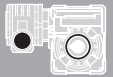

#### QUICK SELECTION / Selezione veloce

input speed ( $n_1$ ) = 1400 min<sup>-1</sup>

Output Speed $n_2$ [min <sup>-1</sup> ]	Ratio $i$	Motor power $P_{1M}$ [kW]	Output torque $M_{2M}$ [Nm]	Service factor f.s.	Nominal power $P_{1R}$ [kW]	Nominal torque $M_{2R}$ [Nm]	Available B5 motor flanges		Available B14 motor flanges		Dynamic efficiency <b>RD</b>	Tooth Module $[mm]$	Ratios code 
							-A	-B	-O	-P			
							56	63	56	63			
5.6	<b>252</b>	0.12	97	1.1	<b>0.14</b>	<b>109</b>	B		B-C		47	2.1	01
3.9	<b>360</b>	0.12	124	0.9	<b>0.11</b>	<b>109</b>	B		B-C		42	2.1	02
2.6	<b>540</b>	0.12*	109	<0.8	<b>0.08</b>	<b>109</b>	B		B-C		39	2.1	03
1.9	<b>720</b>	0.12*	109	<0.8	<b>0.06</b>	<b>109</b>	B		B-C		36	2.1	04
1.6	<b>860</b>	0.12*	109	<0.8	<b>0.06</b>	<b>109</b>	B		B-C		32	1.8	05
1.2	<b>1200</b>	0.12*	109	<0.8	<b>0.05</b>	<b>109</b>	B		B-C		27	1.3	06
1.0	<b>1440</b>	0.12*	109	<0.8	<b>0.04</b>	<b>109</b>	B		B-C		26	2.1	07
0.8	<b>1720</b>	0.12*	109	<0.8	<b>0.04</b>	<b>109</b>	B		B-C		25	1.8	08
0.6	<b>2400</b>	0.12*	104	<0.8	<b>0.03</b>	<b>104</b>	B		B-C		21	1.3	09

**Motor Flanges Available**  
Flange Motore Disponibili

**B) Supplied with Reduction Bushing**  
Fornito con Bussola di Riduzione

**B) Available on Request without reduction bushing**  
Disponibile a Richiesta senza Bussola di Riduzione

**C) Motor Flange Holes Position**  
Posizione Fori Flangia Motore

\* Power higher than the maximum one which can be supported by the gearbox. Select according to the torque  $M_{2R}$   
Potenza superiore a quella massima sopportabile dal riduttore. Selezionare in base al momento torcente  $M_{2R}$

**EN** Unit **53Q** is supplied with synthetic oil, providing "long life" lubrication. For mounting position V5-V6 please contact us. See table 1 for lubrication and recommended quantity. In table 2 please see possible radial loads and axial loads on the gearbox.

**I** Il riduttore tipo **53Q** viene fornito lubrificato a vita con olio sintetico. Per posizioni V5-V6 contattare il ns. servizio tecnico. Vedi tab.1 per oli e quantità consigliati. In tab.2 sono presenti i carichi radiali e assiali applicabili al riduttore.

**D** Für die Lebensdauerschmierung ist das Getriebe der Größe **53Q** mit synthetischem Öl befüllt. Bei Einbaulage V5 oder V6 bitten wir um Rücksprache. In Tabelle 1 ist die Schmiermenge und das empfohlene Schmiermittel angegeben. In Tabelle 2 sind die zulässigen Radial- und Axialbelastungen des Getriebes aufgeführt.

**F** Le réducteur de type **53Q** est fourni lubrifié à vie avec de l'huile synthétique. Concernant les positions V5.V6, contactez notre service d'assistance technique. Voir tableau 1 concernant les huiles et les quantités conseillées. Les charges radiales et axiales applicables au réducteur sont précisées dans le tableau 2.

**E** El reductor tamaño **53Q** se suministra, lubricado de por vida con aceite sintético. Para las posiciones V5 y V6 contactar con nuestro servicio técnico. Ver tabla 1, para cantidades y aceites recomendados. En la tabla 2, se encuentran las cargas radiales y axiales admitidas por el reductor.

**0.14 Lt.**

**■ LUBRICATION 53Q Oil**

**Quantity 0.14/0.03 Lt.**

**AGIP** Telium VSF 320

**SHELL** Omala S4 WE 320

For all details on lubrication and plugs check our website tab. 1  
Per maggiori dettagli su lubrificazione e tappi olio vedi il nostro sito web

**■ RADIAL AND AXIAL LOADS**

**Output shaft**  
Albero di uscita

$n_2$ [min <sup>-1</sup> ]	FA [N]	FR [N]
<b>25</b>	480	2500
<b>15</b>	560	2800

**Input shaft**  
albero in entrata

$n_1$ [min <sup>-1</sup> ]	FA [N]	FR [N]
<b>1400</b>	20	100

\*Strong axial loads in the DX direction are not allowed.  
Non sono consentiti forti carichi assiali con direzione DX

tab. 2



**P53QFB...** Basic wormbox  
Riduttore base

M. flanges	Kit code	øF	A
<b>56B5</b>	K030.4.041	120	61.5
<b>63B5</b>	K030.4.042	140	62.5
<b>56B14</b>	K030.4.046	80	61.5
<b>63B14</b>	K030.4.045	90	62.5

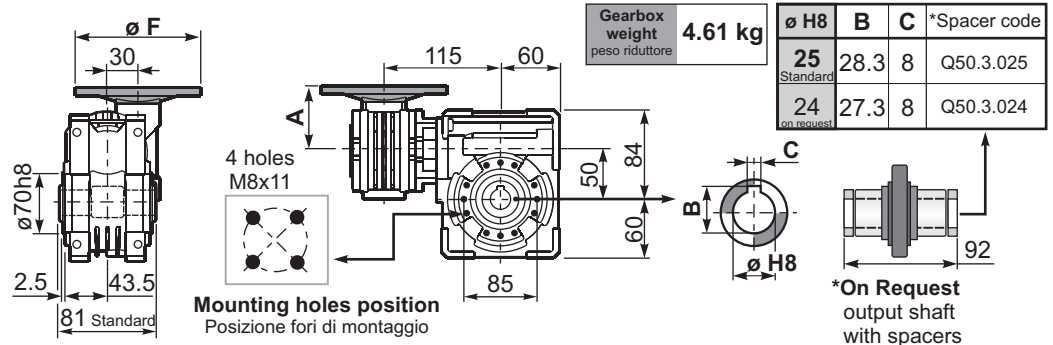

**P53QFC...** Square flange  
Flangia quadrata

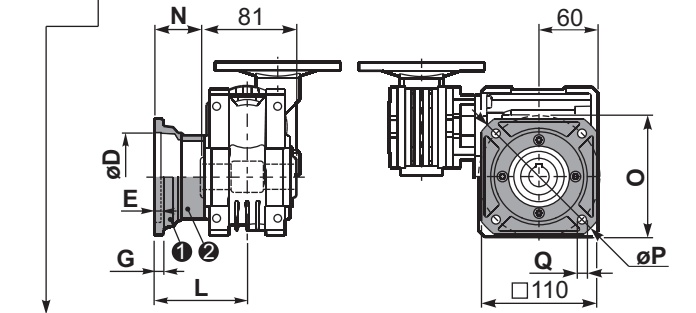

type B	øD	E	G	L	N	O	P	Q	kit code
<b>FC</b>	70 H8	5	9	90	49.5	85	125	11	KQ50.9.010
<b>FL</b>	70 H8	5	9	120	79.5	85	125	11	KQ50.9.011

**P53QF1...** Round flange  
Flangia rotonda

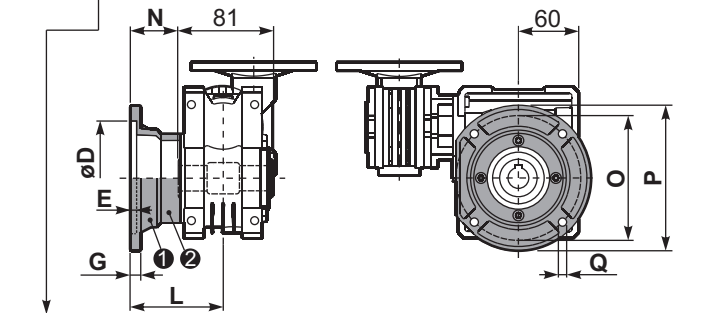

type S	øD	E	G	L	N	O	P	Q	kit code
<b>F1</b>	110 H8	5	10	89	48.5	130	160	9.5	KSQ50.9.012
<b>F2</b>	95 H8	5	14.5	72	31.5	115	140	11	KSQ50.9.013

**P53QFB...** Feet  
Piedini

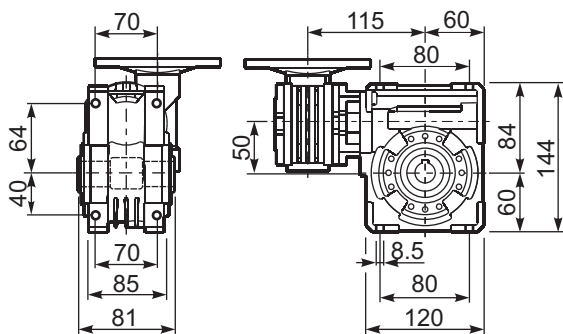

**P53QBR...** Reaction arm  
Braccio di reazione

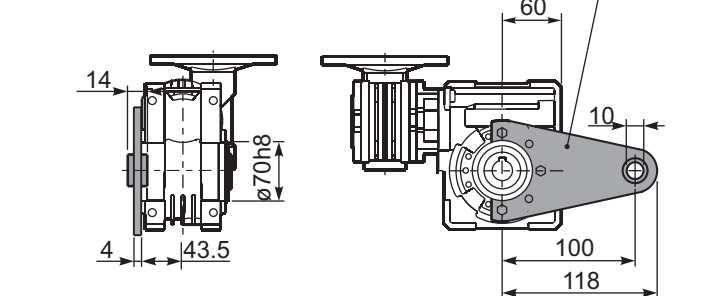

**R53QFB...** Input shaft  
Albero in entrata

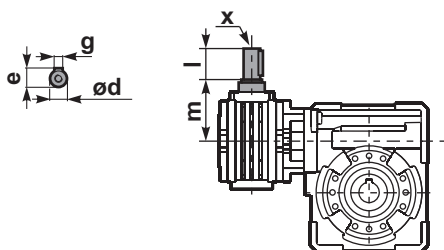

	ød	e	g	l	m	x	kit code
type B	9 h6	10.2	3	20	58	-	K030.5.006 PAM63
type S	-	-	-	-	-	-	-

**P53Q.....S...** Single Shaft  
Albero lento semplice

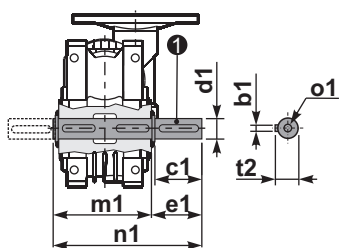

① kit cod. K050.5.028 type B  
kit cod. KS050.5.030 type S

**P53Q.....D...** Double Shaft  
Albero lento bisp.

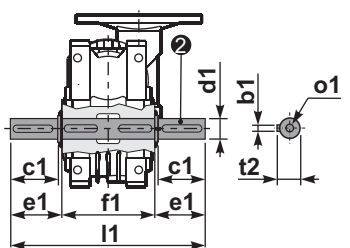

② kit cod. K050.5.029 type B  
kit cod. KS050.5.031 type S

	b1	c1	d1	e1	f1	l1	m1	n1	t2	ø1
type B	8	52	25 <sup>-0.005</sup> <sub>-0.020</sub>	59.5	81	200	86.5	146	28	M8x20
type S	8	50	24 <sup>-0.005</sup> <sub>-0.020</sub>	68.8	81	218	86.5	155	27	M8x20

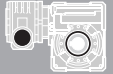

#### QUICK SELECTION / Selezione veloce

input speed ( $n_1$ ) = 1400 min<sup>-1</sup>

Output Speed $n_2$ [min <sup>-1</sup> ]	Ratio $i$	Motor power $P_{1M}$ [kW]	Output torque $M_{2M}$ [Nm]	Service factor f.s.	Nominal power $P_{1R}$ [kW]	Nominal torque $M_{2R}$ [Nm]	Available B5 motor flanges		Available B14 motor flanges		Dynamic efficiency <b>RD</b>	Tooth Module  [mm]	Ratios code 
							-A	-B	-O	-P			
							56	63	56	63			
5.6	<b>252</b>	0.18	142	1.6	<b>0.29</b>	<b>230</b>	B		B-C		46	2.7	01
3.9	<b>360</b>	0.18	181	1.3	<b>0.23</b>	<b>230</b>	B		B-C		41	2.7	02
2.6	<b>540</b>	0.12	164	1.4	<b>0.17</b>	<b>230</b>	B		B-C		37	2.7	03
1.9	<b>720</b>	0.12	200	1.1	<b>0.14</b>	<b>230</b>	B		B-C		34	2.7	04
1.3	<b>1080</b>	0.12	265	0.9	<b>0.10</b>	<b>230</b>	B		B-C		30	2.7	05
1.0	<b>1440</b>	0.12*	230	<0.8	<b>0.09</b>	<b>230</b>	B		B-C		27	2.7	06
0.5	<b>2745</b>	0.12*	230	<0.8	<b>0.05</b>	<b>230</b>	B		B-C		23	2.1	07

**A) Motor Flanges Available**  
Flange Motore Disponibili

**B) Supplied with Reduction Bushing**  
Fornito con Bussola di Riduzione

**B) Available on Request without reduction bushing**  
Disponibile a Richiesta senza Bussola di Riduzione

**C) Motor Flange Holes Position**  
Posizione Fori Flangia Motore

\* Power higher than the maximum one which can be supported by the gearbox. Select according to the torque  $M_{2R}$   
Potenza superiore a quella massima sopportabile dal riduttore. Selezionare in base al momento torcente  $M_{2R}$

**EN** Unit **63Q** is supplied with synthetic oil, providing "long life" lubrication. For mounting position V5-V6 please contact us. See table 1 for lubrication and recommended quantity. In table 2 please see possible radial loads and axial loads on the gearbox.

**I** Il riduttore tipo **63Q** viene fornito lubrificato a vita con olio sintetico. Per posizioni V5-V6 contattare il ns. servizio tecnico. Vedi tab.1 per oli e quantità consigliati. In tab.2 sono presenti i carichi radiali e assiali applicabili al riduttore.

**D** Für die Lebensdauerschmierung ist das Getriebe der Größe **63Q** mit synthetischem Öl befüllt. Bei Einbaulage V5 oder V6 bitten wir um Rücksprache. In Tabelle 1 ist die Schmiermenge und das empfohlene Schmiermittel angegeben. In Tabelle 2 sind die zulässigen Radial- und Axialbelastungen des Getriebes aufgeführt.

**F** Le réducteur de type **63Q** est fourni lubrifié à vie avec de l'huile synthétique. Concernant les positions V5.V6, contactez notre service d'assistance technique. Voir tableau 1 concernant les huiles et les quantités conseillées. Les charges radiales et axiales applicables au réducteur sont précisées dans le tableau 2.

**E** El reductor tamaño **63Q** se suministra, lubricado de por vida con aceite sintético. Para las posiciones V5 y V6 contactar con nuestro servicio técnico. Ver tabla 1, para cantidades y aceites recomendados. En la tabla 2, se encuentran las cargas radiales y axiales admitidas por el reductor.

0.30 Lt. 0.03 Lt.

### LUBRICATION 63Q Oil Quantity 0.30/0.03 Lt.

<b>AGIP</b> Telium VSF 320	<b>SHELL</b> Omala S4 WE 320
----------------------------	------------------------------

For all details on lubrication and plugs check our website **tab. 1**  
Per maggiori dettagli su lubrificazione e tappi olio vedi il nostro sito web

### RADIAL AND AXIAL LOADS

**Output shaft**  
Albero di uscita

$n_2$ [min <sup>-1</sup> ]	FA [N]	FR [N]
<b>25</b>	700	3800
<b>15</b>	800	4000

**Input shaft**  
albero in entrata

$n_1$ [min <sup>-1</sup> ]	FA [N]	FR [N]
<b>1400</b>	20	100

\*Strong axial loads in the DX direction are not allowed.  
Non sono consentiti forti carichi assiali con direzione DX

**tab. 2**

**P63QFB...** Basic wormbox  
Riduttore base

Gearbox weight  
peso riduttore **7.25 kg**

M. flanges	Kit code	øF	A
<b>56B5</b>	K030.4.041	120	61.5
<b>63B5</b>	K030.4.042	140	62.5
<b>56B14</b>	K030.4.046	80	61.5
<b>63B14</b>	K030.4.045	90	62.5

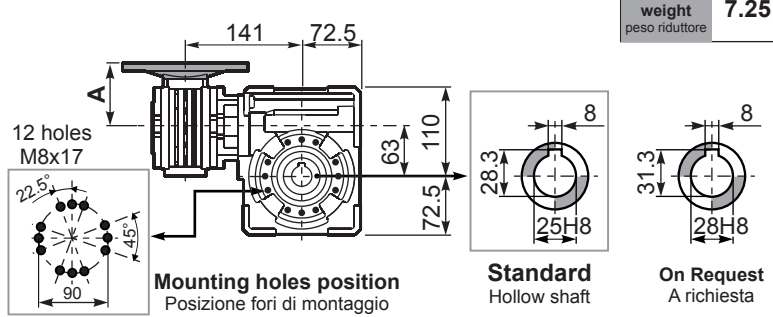
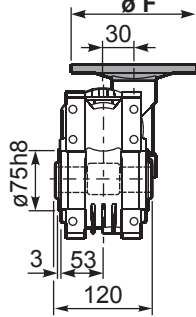

**P63QFC...** Square flange  
Flangia quadrata

**P63QF1...** Round flange  
Flangia rotonda

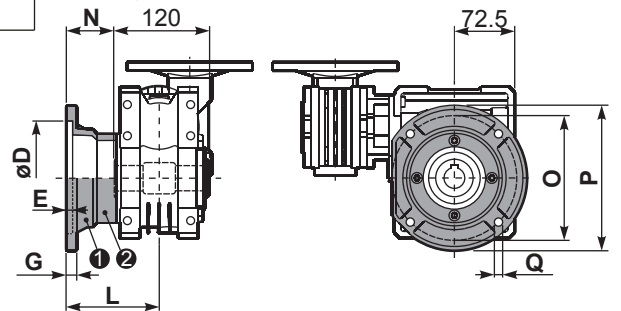
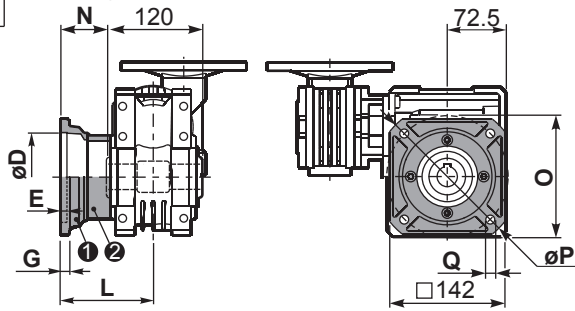

type B	øD	E	G	L	N	O	P	Q	kit code
<b>FC</b>	115 <sup>+0.20</sup> / <sub>+0.15</sub>	6	12	86	26	150	180	11	1 KQ63.9.010 2 -
<b>FL</b>	115 <sup>+0.20</sup> / <sub>+0.15</sub>	6	12	116	56	150	180	11	1 KQ63.9.010 2 K063.0.200

type S	øD	E	G	L	N	O	P	Q	kit code
<b>F1</b>	130 <sup>+0.20</sup> / <sub>+0.15</sub>	7	13	110	50	165	200	13	1 KS070.9.013 2 -
<b>F2</b>	115 <sup>+0.20</sup> / <sub>+0.15</sub>	7	13	124	64	150	175	11	1 KS063.9.013 2 -
<b>F3</b>	110 <sup>+0.035</sup> / <sub>0</sub>	5	11	90	30	130	160	10	1 KS063.9.011 2 -

**P63QFB...** Feet  
Piedini

**P63QBR...** Reaction arm  
Braccio di reazione

kit cod. K063.9.027

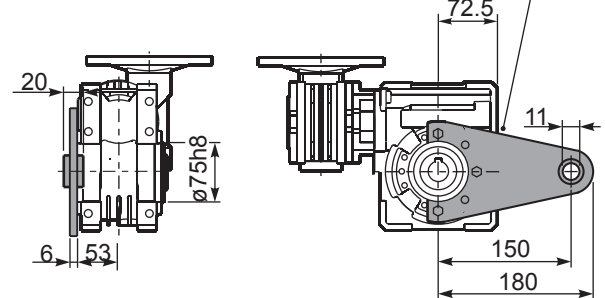
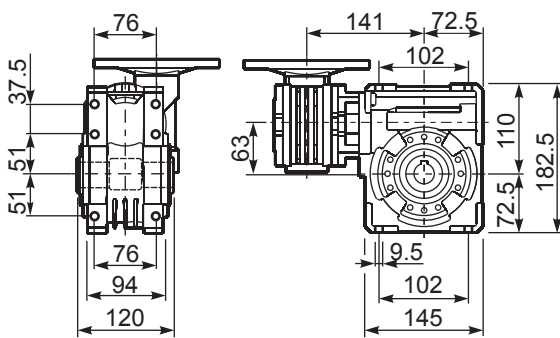

**R63QFB...** Input shaft  
Albero in entrata

**P63Q.....S...** Single Shaft  
Albero lento semplice

**P63Q.....D...** Double Shaft  
Albero lento bisp.

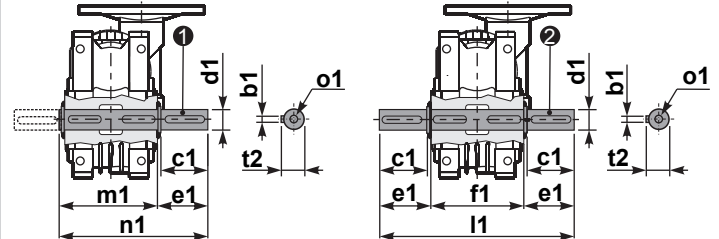
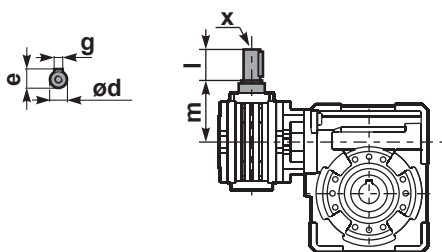

1 kit cod. K063.5.028 type B 2 kit cod. K063.5.029 type B

	ød	e	g	l	m	x	kit code
type B	9 h6	10.2	3	20	58	-	1 K030.5.006 PAM63 2 -
type S	-	-	-	-	-	-	1 - 2 -

	b1	c1	d1	e1	f1	l1	m1	n1	t2	o1
type B	8	60	25 <sup>-0.005</sup> / <sub>-0.020</sub>	63.2	120	246.4	126.8	190	28	M8x20
type S	-	-	-	-	-	-	-	-	-	-

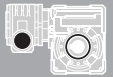

#### QUICK SELECTION / Selezione veloce

input speed ( $n_1$ ) = 1400 min<sup>-1</sup>

Output Speed $n_2$ [min <sup>-1</sup> ]	Ratio $i$	Motor power $P_{1M}$ [kW]	Output torque $M_{2M}$ [Nm]	Service factor f.s.	Nominal power $P_{1R}$ [kW]	Nominal torque $M_{2R}$ [Nm]	Available B5 motor flanges		Available B14 motor flanges			Dynamic efficiency <b>RD</b>	Tooth Module  [mm]	Ratios code 
							-B	-C	-O	-P	-Q			
							63	71	56	63	71			
5.6	<b>252</b>	0.25	198	1.3	<b>0.33</b>	<b>265</b>	<b>B</b>		B-C	B-C		46	2.7	01
3.9	<b>360</b>	0.18	186	1.4	<b>0.26</b>	<b>265</b>	<b>B</b>		B-C	B-C		42	2.7	02
2.8	<b>504</b>	0.18	241	1.1	<b>0.20</b>	<b>265</b>	<b>B</b>		B-C	B-C		39	2.7	03
1.9	<b>756</b>	0.12	204	1.3	<b>0.16</b>	<b>265</b>	<b>B</b>		B-C	B-C		33	2.7	04
1.4	<b>1008</b>	0.12	256	1.0	<b>0.12</b>	<b>265</b>	<b>B</b>		B-C	B-C		31	2.7	05
1.1	<b>1332</b>	0.12*	265	<0.8	<b>0.10</b>	<b>265</b>	<b>B</b>		B-C	B-C		30	2.7	06
0.8	<b>1656</b>	0.12*	265	<0.8	<b>0.08</b>	<b>265</b>	<b>B</b>		B-C	B-C		28	2.7	07
0.6	<b>2160</b>	0.12*	265	<0.8	<b>0.07</b>	<b>265</b>	<b>B</b>		B-C	B-C		26	2.7	08
0.6	<b>2520</b>	0.12*	265	<0.8	<b>0.06</b>	<b>265</b>	<b>B</b>		B-C	B-C		25	2.7	09

**A** Motor Flanges Available  
Flange Motore Disponibili

**B** Supplied with Reduction Bushing  
Fornito con Bussola di Riduzione

**B** Available on Request without reduction bushing  
Disponibile a Richiesta senza Bussola di Riduzione

**C** Motor Flange Holes Position  
Posizione Fori Flangia Motore

\* Power higher than the maximum one which can be supported by the gearbox. Select according to the torque  $M_{2R}$   
Potenza superiore a quella massima sopportabile dal riduttore. Selezionare in base al momento torcente  $M_{2R}$

**EN** Unit **64Q** is supplied with synthetic oil, providing "long life" lubrication. For mounting position V5-V6 please contact us. See table 1 for lubrication and recommended quantity. In table 2 please see possible radial loads and axial loads on the gearbox.

**I** Il riduttore tipo **64Q** viene fornito lubrificato a vita con olio sintetico. Per posizioni V5-V6 contattare il ns. servizio tecnico. Vedi tab.1 per oli e quantità consigliati. In tab.2 sono presenti i carichi radiali e assiali applicabili al riduttore.

**D** Für die Lebensdauerschmierung ist das Getriebe der Größe **64Q** mit synthetischem Öl befüllt. Bei Einbaulage V5 oder V6 bitten wir um Rücksprache. In Tabelle 1 ist die Schmiermenge und das empfohlene Schmiermittel angegeben. In Tabelle 2 sind die zulässigen Radial- und Axialbelastungen des Getriebes aufgeführt.

**F** Le réducteur de type **64Q** est fourni lubrifié à vie avec de l'huile synthétique. Concernant les positions V5.V6, contactez notre service d'assistance technique. Voir tableau 1 concernant les huiles et les quantités conseillées. Les charges radiales et axiales applicables au réducteur sont précisées dans le tableau 2.

**E** El reductor tamaño **64Q** se suministra, lubricado de por vida con aceite sintético. Para las posiciones V5 y V6 contactar con nuestro servicio técnico. Ver tabla 1, para cantidades y aceites recomendados. En la tabla 2, se encuentran las cargas radiales y axiales admitidas por el reductor.

0.30 Lt.

**■ LUBRICATION 64Q Oil**  
Quantity 0.30/0.09 Lt.

0.09 Lt.

<b>AGIP</b> Telium VSF 320	<b>SHELL</b> Omala S4 WE 320
----------------------------	------------------------------

For all details on lubrication and plugs check our website **tab. 1**  
Per maggiori dettagli su lubrificazione e tappi olio vedi il nostro sito web

### ■ RADIAL AND AXIAL LOADS

**Output shaft**  
Albero di uscita

$n_2$ [min <sup>-1</sup> ]	FA [N]	FR [N]
<b>25</b>	700	3800
<b>15</b>	800	4000

**Input shaft**  
albero in entrata

$n_1$ [min <sup>-1</sup> ]	FA [N]	FR [N]
<b>1400</b>	42	210

\*Strong axial loads in the DX direction are not allowed.  
Non sono consentiti forti carichi assiali con direzione DX

**tab. 2**

**P64QFB...** Basic wormbox  
Riduttore base

Gearbox weight  
peso riduttore **7.25 kg**

M. flanges	Kit code	øF	A
<b>63B5</b>	K050.4.041	138	74
<b>71B5</b>	K050.4.042	160	71.5
<b>56B14</b>	KC40.4.049	80	71.5
<b>63B14</b>	K050.4.047	90	74
<b>71B14</b>	K050.4.045	105	71.5

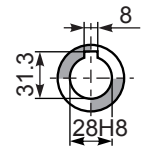
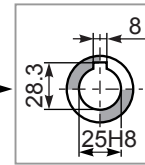
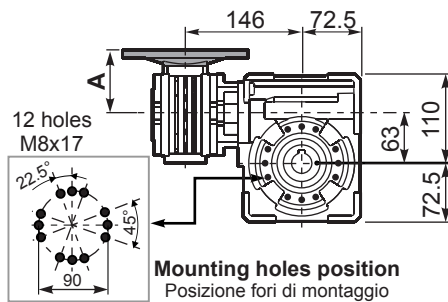
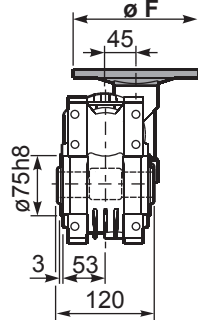

**Mounting holes position**  
Posizione fori di montaggio

**Standard**  
Hollow shaft

**On Request**  
A richiesta

**P64QFC...** Square flange  
Flangia quadrata

**P64QF1...** Round flange  
Flangia rotonda

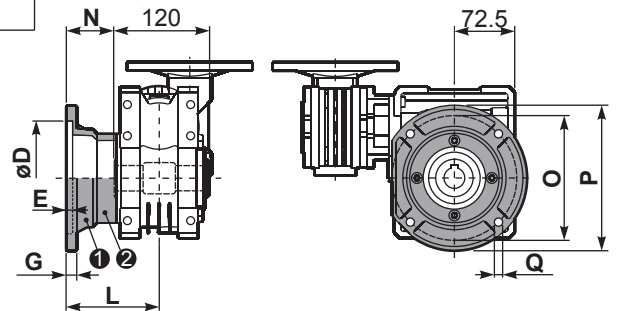
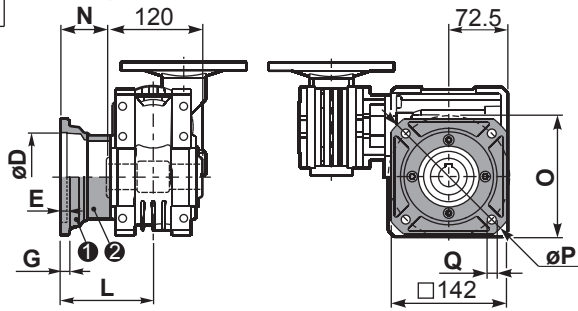

type B	øD	E	G	L	N	O	P	Q	kit code
<b>FC</b>	115 <sup>+0.20</sup> / <sub>+0.15</sub>	6	12	86	26	150	180	11	① KQ63.9.010 ② -
<b>FL</b>	115 <sup>+0.20</sup> / <sub>+0.15</sub>	6	12	116	56	150	180	11	① KQ63.9.010 ② K063.0.200

type S	øD	E	G	L	N	O	P	Q	kit code
<b>F1</b>	130 <sup>+0.20</sup> / <sub>+0.15</sub>	7	13	110	50	165	200	13	① KS070.9.013 ② -
<b>F2</b>	115 <sup>+0.20</sup> / <sub>+0.15</sub>	7	13	124	64	150	175	11	① KS063.9.013 ② -
<b>F3</b>	110 <sup>+0.035</sup> / <sub>0</sub>	5	11	90	30	130	160	10	① KS063.9.011 ② -

**P64QFB...** Feet  
Piedi

**P64QBR...** Reaction arm  
Braccio di reazione

kit cod. K063.9.027

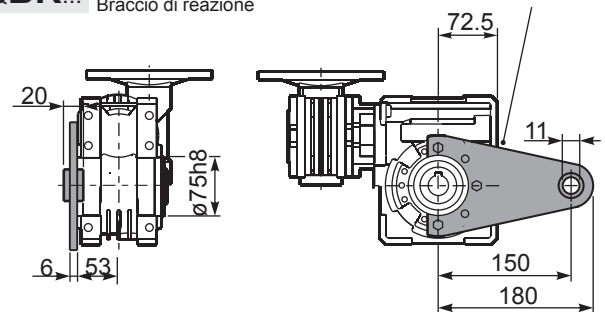
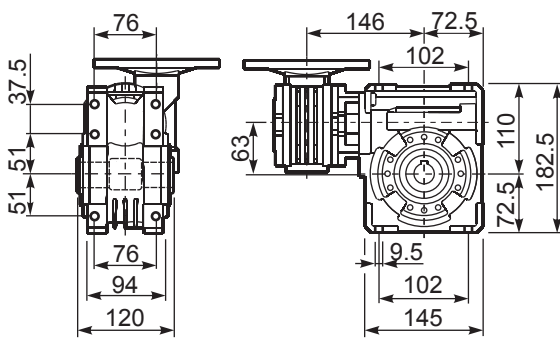

**R64QFB...** Input shaft  
Albero in entrata

**P64Q.....S...** Single Shaft  
Albero lento semplice

**P64Q.....D...** Double Shaft  
Albero lento bisp.

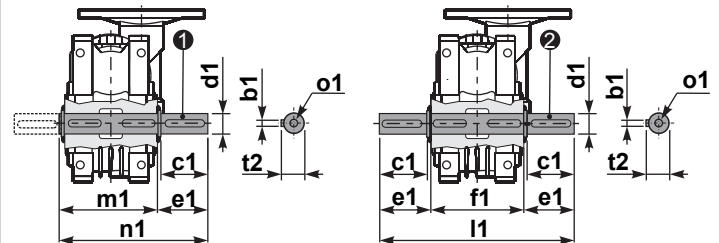
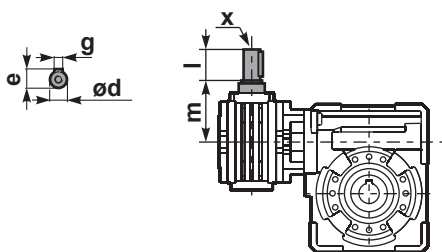

① kit cod. K063.5.028 type B

② kit cod. K063.5.029 type B

	ød	e	g	l	m	x	kit code
type B	11 h6	12.5	4	30	68	-	① K045.5.006 PAM71 ② -
type S	-	-	-	-	-	-	① - ② -

	b1	c1	d1	e1	f1	l1	m1	n1	t2	o1
type B	8	60	25 <sup>-0.005</sup> / <sub>-0.020</sub>	63.2	120	246.4	126.8	190	28	M8x20
type S	-	-	-	-	-	-	-	-	-	-

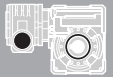

#### QUICK SELECTION / Selezione veloce

input speed ( $n_1$ ) = 1400 min<sup>-1</sup>

Output Speed $n_2$ [min <sup>-1</sup> ]	Ratio $i$	Motor power $P_{1M}$ [kW]	Output torque $M_{2M}$ [Nm]	Service factor f.s.	Nominal power $P_{1R}$ [kW]	Nominal torque $M_{2R}$ [Nm]	Available B5 motor flanges		Available B14 motor flanges			Dynamic efficiency <b>RD</b>	Tooth Module $[mm]$	Ratios code 
							-B	-C	-O	-P	-Q			
							63	71	56	63	71			
5	<b>280</b>	0.37	403	0.9	<b>0.33</b>	<b>359</b>	B		B-C	B-C		57	3.10	01
3.5	<b>400</b>	0.25	314	1.1	<b>0.29</b>	<b>359</b>	B		B-C	B-C		46	3.10	02
2.5	<b>560</b>	0.25	420	0.9	<b>0.21</b>	<b>359</b>	B		B-C	B-C		44	3.10	03
1.7	<b>840</b>	0.18	423	0.8	<b>0.15</b>	<b>359</b>	B		B-C	B-C		41	3.10	04
1.3	<b>1120</b>	0.12	339	1.1	<b>0.13</b>	<b>359</b>	B		B-C	B-C		37	3.10	05
0.9	<b>1480</b>	0.09	336	1.1	<b>0.10</b>	<b>359</b>	B		B-C	B-C		37	3.10	06
0.8	<b>1840</b>	0.09	373	1.0	<b>0.09</b>	<b>359</b>	B		B-C	B-C		33	3.10	07
0.6	<b>2400</b>	0.06	275	1.3	<b>0.08</b>	<b>359</b>	B		B-C	B-C		28	3.10	08
0.5	<b>2800</b>	0.06	298	1.2	<b>0.07</b>	<b>359</b>	B		B-C	B-C		26	3.10	09
0.3	<b>4080</b>	0.06	250	1.4	<b>0.09</b>	<b>359</b>	B		B-C	B-C		15	3.10	10

**A** Motor Flanges Available  
Flange Motore Disponibili

**B** Supplied with Reduction Bushing  
Fornito con Bussola di Riduzione

**B** Available on Request without reduction bushing  
Disponibile a Richiesta senza Bussola di Riduzione

**C** Motor Flange Holes Position  
Posizione Fori Flangia Motore

**EN** Unit **74Q** is supplied with synthetic oil, providing "long life" lubrication. For mounting position V5-V6 please contact us. See table 1 for lubrication and recommended quantity. In table 2 please see possible radial loads and axial loads on the gearbox.

**I** Il riduttore tipo **74Q** viene fornito lubrificato a vita con olio sintetico. Per posizioni V5-V6 contattare il ns. servizio tecnico. Vedi tab.1 per oli e quantità consigliati. In tab.2 sono presenti i carichi radiali e assiali applicabili al riduttore.

**D** Für die Lebensdauerschmierung ist das Getriebe der Größe **74Q** mit synthetischem Öl befüllt. Bei Einbaulage V5 oder V6 bitten wir um Rücksprache. In Tabelle 1 ist die Schmiermenge und das empfohlene Schmiermittel angegeben. In Tabelle 2 sind die zulässigen Radial- und Axialbelastungen des Getriebes aufgeführt.

**F** Le réducteur de type **74Q** est fourni lubrifié à vie avec de l'huile synthétique. Concernant les positions V5.V6, contactez notre service d'assistance technique. Voir tableau 1 concernant les huiles et les quantités conseillées. Les charges radiales et axiales applicables au réducteur sont précisées dans le tableau 2.

**E** El reductor tamaño **74Q** se suministra, lubricado de por vida con aceite sintético. Para las posiciones V5 y V6 contactar con nuestro servicio técnico. Ver tabla 1, para cantidades y aceites recomendados. En la tabla 2, se encuentran las cargas radiales y axiales admitidas por el reductor.

**LUBRICATION 74Q Oil**  
Quantity 0.40/0.09 Lt.

**AGIP** Telium VSF 320

**SHELL** Omala S4 WE 320

For all details on lubrication and plugs check our website **tab. 1**  
Per maggiori dettagli su lubrificazione e tappi olio vedi il nostro sito web

#### RADIAL AND AXIAL LOADS

**Output shaft**  
Albero di uscita

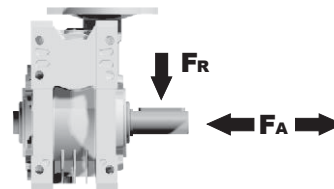

$n_2$ [min <sup>-1</sup> ]	FA [N]	FR [N]
25	880	4400
15	1000	5000

**Input shaft**  
albero in entrata

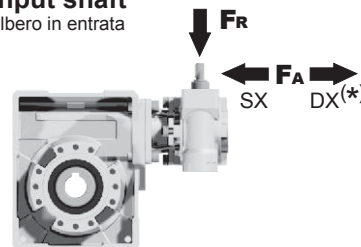

$n_1$ [min <sup>-1</sup> ]	FA [N]	FR [N]
1400	42	210

**\*Strong axial loads in the DX direction are not allowed.**  
Non sono consentiti forti carichi assiali con direzione DX

**tab. 2**

**P74QFB...** Basic wormbox  
Riduttore base

Gearbox weight  
peso riduttore **11.4 kg**

M. flanges	Kit code	øF	A
<b>63B5</b>	K050.4.041	138	74
<b>71B5</b>	K050.4.042	160	71.5
<b>56B14</b>	KC40.4.049	80	71.5
<b>63B14</b>	K050.4.047	90	74
<b>71B14</b>	K050.4.045	105	71.5

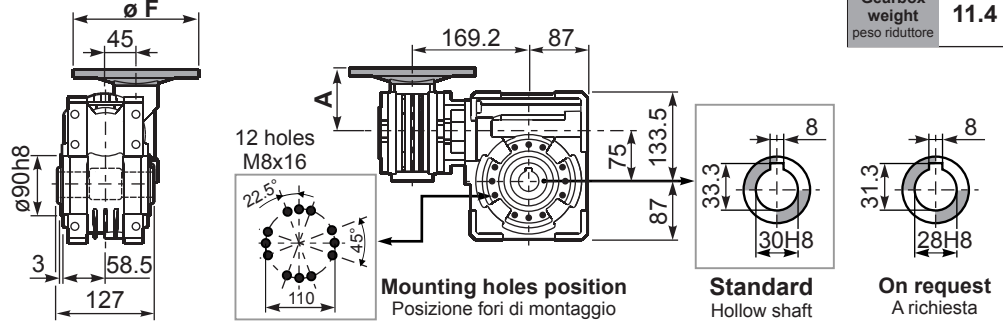

**P74QFC...** Square flange  
Flangia quadrata

**P74QFL...** Square flange  
Flangia quadrata

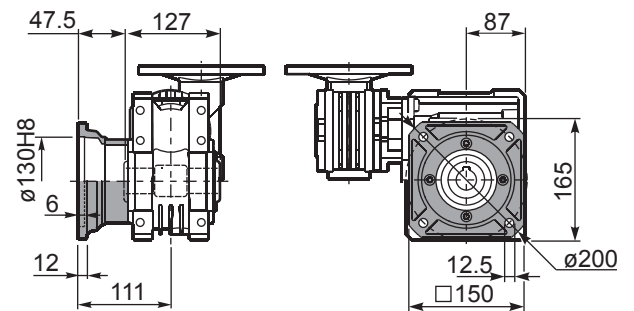
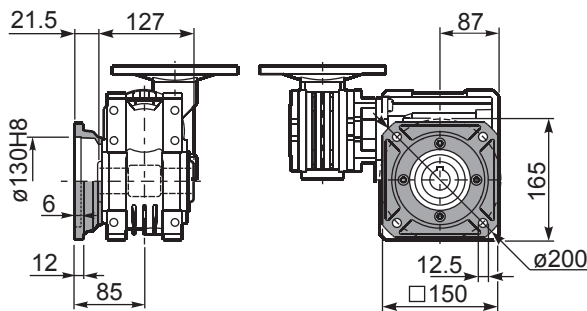

**P74QFB...** Feet  
Piedini

**P74QBR...** Reaction arm  
Braccio di reazione

kit cod. KQ75.9.027

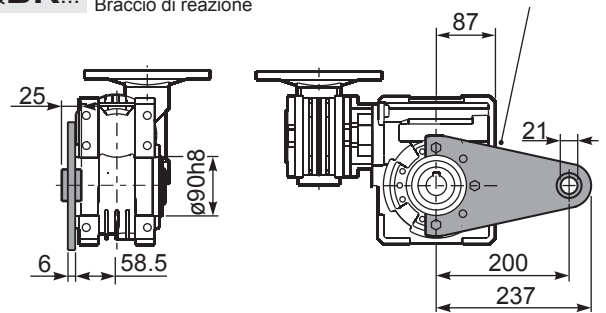
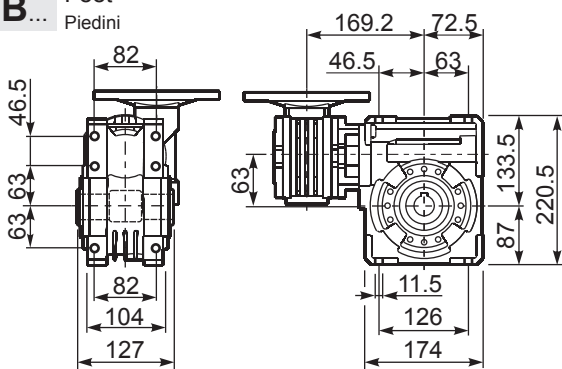

**R74QFB...** Input shaft  
Albero in entrata

**P74Q.....S...** Single Shaft  
Albero lento semplice

**P74Q.....D...** Double Shaft  
Albero lento bisp.

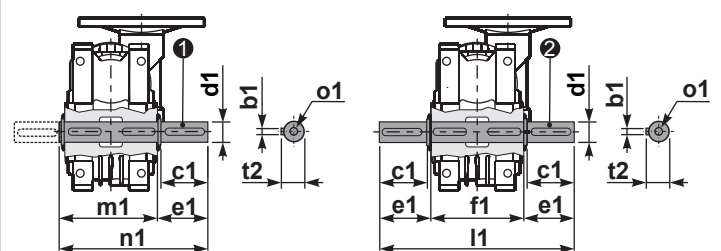
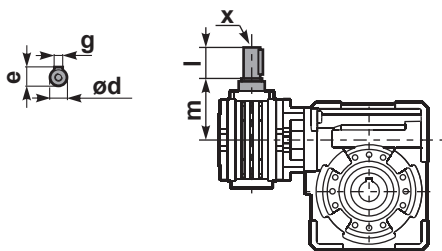

① kit cod. KQ75.5.028 Standard    ② kit cod. KQ75.5.029 Standard  
kit cod. KQ75.5.026 On request    kit cod. KQ75.5.027 On request

	ød	e	g	l	m	x	kit code
type B	11 h6	12.5	4	30	68	-	① K045.5.006 PAM71 ② -
type S	-	-	-	-	-	-	① - ② -

	b1	c1	d1	e1	f1	l1	m1	n1	t2	o1
Standard	8	60	30 <sup>-0.005</sup> <sub>-0.020</sub>	65	127	255	134	199	33	M8x20
On request	8	60	28 <sup>-0.005</sup> <sub>-0.020</sub>	65	127	255	134	199	31	M8x20

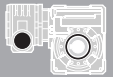

#### QUICK SELECTION / Selezione veloce

input speed ( $n_1$ ) = 1400 min<sup>-1</sup>

Output Speed $n_2$ [min <sup>-1</sup> ]	Ratio $i$	Motor power $P_{1M}$ [kW]	Output torque $M_{2M}$ [Nm]	Service factor f.s.	Nominal power $P_{1R}$ [kW]	Nominal torque $M_{2R}$ [Nm]	Available B5 motor flanges		Available B14 motor flanges			Dynamic efficiency <b>RD</b>	Tooth Module  [mm]	Ratios code 
							-B	-C	-O	-P	-Q			
							63	71	56	63	71			
10	<b>140</b>	0.37	205	1.8	<b>0.66</b>	<b>368</b>	<b>B</b>		B-C	B-C		58	4.5	01
7.1	<b>196</b>	0.37	257	1.4	<b>0.53</b>	<b>368</b>	<b>B</b>		B-C	B-C		52	4.7	02
5.0	<b>280</b>	0.37	332	1.6	<b>0.58</b>	<b>518</b>	<b>B</b>		B-C	B-C		47	4.7	03
3.6	<b>392</b>	0.37	435	1.2	<b>0.44</b>	<b>518</b>	<b>B</b>		B-C	B-C		44	4.7	04
2.4	<b>588</b>	0.25	371	1.4	<b>0.35</b>	<b>518</b>	<b>B</b>		B-C	B-C		37	4.7	05
1.8	<b>784</b>	0.25	455	1.1	<b>0.28</b>	<b>518</b>	<b>B</b>		B-C	B-C		34	4.7	06
1.4	<b>1036</b>	0.18	420	1.2	<b>0.22</b>	<b>518</b>	<b>B</b>		B-C	B-C		33	4.7	07
1.1	<b>1288</b>	0.18	474	1.1	<b>0.20</b>	<b>518</b>	<b>B</b>		B-C	B-C		30	4.7	08
0.7	<b>1960</b>	0.12	449	1.2	<b>0.14</b>	<b>518</b>	<b>B</b>		B-C	B-C		28	4.7	09
0.5	<b>2856</b>	0.12	584	0.9	<b>0.11</b>	<b>518</b>	<b>B</b>		B-C	B-C		25	4.7	10

**A) Motor Flanges Available**  
Flange Motore Disponibili

**B) Supplied with Reduction Bushing**  
Fornito con Bussola di Riduzione

**B) Available on Request without reduction bushing**  
Disponibile a Richiesta senza Bussola di Riduzione

**C) Motor Flange Holes Position**  
Posizione Fori Flangia Motore

**EN** Unit **84Q** is supplied with synthetic oil, providing "long life" lubrication. For mounting position V5-V6 please contact us. See table 1 for lubrication and recommended quantity. In table 2 please see possible radial loads and axial loads on the gearbox.

**I** Il riduttore tipo **84Q** viene fornito lubrificato a vita con olio sintetico. Per posizioni V5-V6 contattare il ns. servizio tecnico. Vedi tab.1 per oli e quantità consigliati. In tab.2 sono presenti i carichi radiali e assiali applicabili al riduttore.

**D** Für die Lebensdauerschmierung ist das Getriebe der Größe **84Q** mit synthetischem Öl befüllt. Bei Einbaulage V5 oder V6 bitten wir um Rücksprache. In Tabelle 1 ist die Schmiermenge und das empfohlene Schmiermittel angegeben. In Tabelle 2 sind die zulässigen Radial - und Axialbelastungen des Getriebes aufgeführt.

**F** Le réducteur de type **84Q** est fourni lubrifié à vie avec de l'huile synthétique. Concernant les positions V5.V6, contactez notre service d'assistance technique. Voir tableau 1 concernant les huiles et les quantités conseillées. Les charges radiales et axiales applicables au réducteur sont précisées dans le tableau 2.

**E** El reductor tamaño **84Q** se suministra, lubricado de por vida con aceite sintético. Para las posiciones V5 y V6 contactar con nuestro servicio técnico. Ver tabla 1, para cantidades y aceites recomendados. En la tabla 2, se encuentran las cargas radiales y axiales admitidas por el reductor.

**1.20 Lt.**

**■ LUBRICATION 84Q Oil**

**Quantity 1.20/0.09 Lt.**

**0.09 Lt.**

<b>AGIP</b> Telium VSF 320	<b>SHELL</b> Omala S4 WE 320
----------------------------	------------------------------

For all details on lubrication and plugs check our website **tab. 1**  
Per maggiori dettagli su lubrificazione e tappi olio vedi il nostro sito web

### ■ RADIAL AND AXIAL LOADS

**Output shaft**  
Albero di uscita

$n$ [min <sup>-1</sup> ]	FA [N]	FR [N]
25	1000	5000
15	1160	5800

**Input shaft**  
albero in entrata

$n$ [min <sup>-1</sup> ]	FA [N]	FR [N]
1400	42	210

\*Strong axial loads in the DX direction are not allowed.  
Non sono consentiti forti carichi assiali con direzione DX

**tab. 2**



**P84QFB...** Basic wormbox  
Riduttore base

Gearbox weight  
peso riduttore **16.2 kg**

M. flanges	Kit code	øF	A
<b>63B5</b>	K050.4.041	138	74
<b>71B5</b>	K050.4.042	160	71.5
<b>56B14</b>	KC40.4.049	80	71.5
<b>63B14</b>	K050.4.047	90	74
<b>71B14</b>	K050.4.045	105	71.5

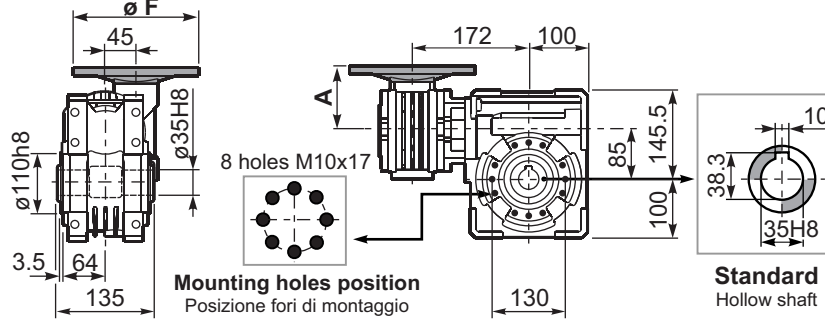

**Mounting holes position**  
Posizione fori di montaggio

**Standard**  
Hollow shaft

**P84QFC...** Output flange  
Flangia uscita

**P84QF1...** Output flange  
Flangia uscita

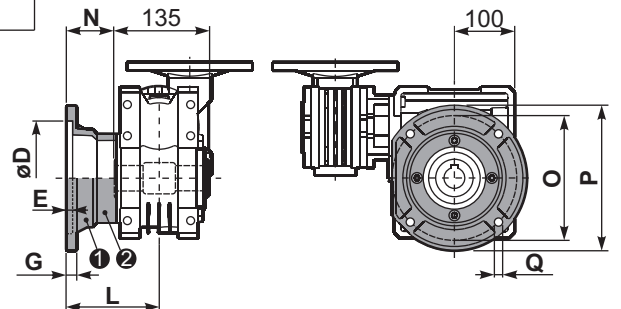
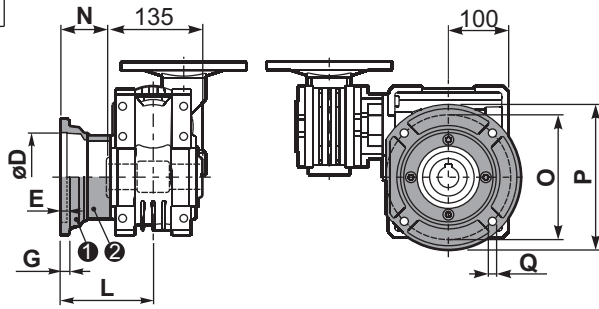

type B	øD	E	G	L	N	O	P	Q	kit code
<b>FC</b>	152 <sup>+0.06</sup> / <sub>+0.00</sub>	5	16	108	40.5	176	205	13	① K085.9.010 ② -
<b>FL</b>	152 <sup>+0.06</sup> / <sub>+0.00</sub>	5	16	148.5	81	176	205	13	① K085.9.010 ② K085.0.201

type S	øD	E	G	L	N	O	P	Q	kit code
<b>F1</b>	130 H7	5	13	117.5	50	165	200	11.5	① KS085.9.012 ② -
<b>F2</b>	152 <sup>+0.06</sup> / <sub>+0.00</sub>	5	15	147.5	80	180	205	12.5	① KS085.9.013 ② -
<b>F4</b>	130 H7	5	13	106.5	39	165	200	13	① KS085.9.015 ② -

**P84QFB...** Feet  
Piedi

**P84QBR...** Reaction arm  
Braccio di reazione

kit cod. K085.9.027

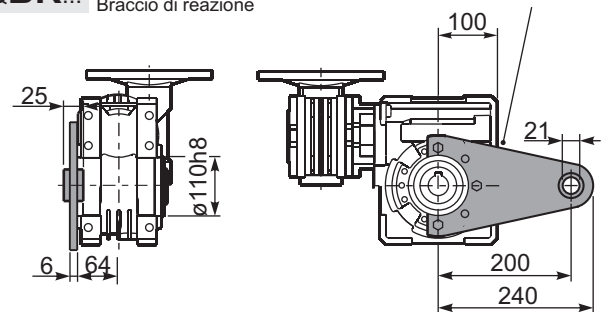
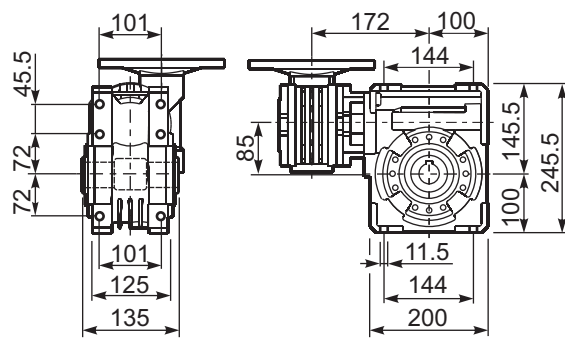

**R84QFB...** Input shaft  
Albero in entrata

**P84Q.....S...** Single Shaft  
Albero lento semplice

**P84Q.....D...** Double Shaft  
Albero lento bisp.

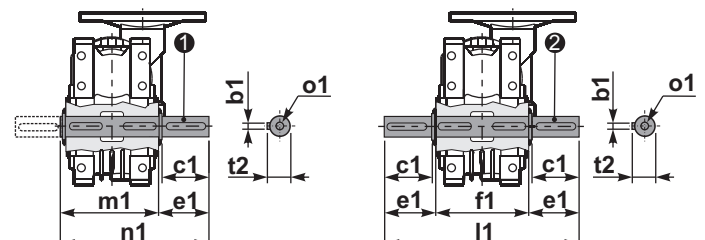
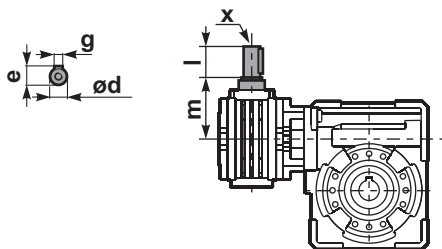

① kit cod. K085.5.028 type B    ② kit cod. K085.5.029 type B

	ød	e	g	l	m	x	kit code
type B	11 h6	12.5	4	30	68	-	① K045.5.006 PAM71 ② -
type S	-	-	-	-	-	-	① - ② -

	b1	c1	d1	e1	f1	l1	m1	n1	t2	o1
type B	10	60	35 <sup>-0.005</sup> / <sub>-0.020</sub>	73.5	135	282	141	214.5	38	M10x23
type S	-	-	-	-	-	-	-	-	-	-

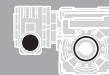

#### QUICK SELECTION / Selezione veloce

input speed ( $n_1$ ) = 1400 min<sup>-1</sup>

Output Speed $n_2$ [min <sup>-1</sup> ]	Ratio $i$	Motor power $P_{1M}$ [kW]	Output torque $M_{2M}$ [Nm]	Service factor f.s.	Nominal power $P_{1R}$ [kW]	Nominal torque $M_{2R}$ [Nm]	Available B5 motor flanges			Available B14 motor flanges				Dynamic efficiency <b>RD</b>	Tooth Module $[mm]$	Ratios code
							-B	-C	-D	-O	-P	-Q	-R			
							63	71	80	56	63	71	80			
6.7	<b>210</b>	0.75	591	1.5	<b>1.1</b>	<b>863</b>	B	B			B-C	B		55	5.6	01
4.7	<b>300</b>	0.75	752	1.3	<b>0.97</b>	<b>978</b>	B	B			B-C	B		49	5.6	02
3.3	<b>420</b>	0.55	741	1.3	<b>0.73</b>	<b>978</b>	B	B			B-C	B		47	5.6	03
2.6	<b>540</b>	0.55	851	1.1	<b>0.63</b>	<b>978</b>	B	B			B-C	B		42	5.6	04
1.8	<b>780</b>	0.37	748	1.3	<b>0.48</b>	<b>978</b>	B	B			B-C	B		38	5.6	05
1.3	<b>1080</b>	0.37	1009	1.0	<b>0.36</b>	<b>978</b>	B			B-C	B-C			37	5.6	06
1.1	<b>1290</b>	0.25	770	1.3	<b>0.32</b>	<b>978</b>	B			B-C	B-C			35	5.6	07
0.8	<b>1800</b>	0.25	921	1.1	<b>0.27</b>	<b>978</b>	B			B-C	B-C			30	5.6	08
0.7	<b>2040</b>	0.18	751	1.3	<b>0.23</b>	<b>978</b>	B			B-C	B-C			30	5.6	09
0.6	<b>2400</b>	0.18	825	1.2	<b>0.21</b>	<b>978</b>	B			B-C	B-C			28	5.6	10
0.5	<b>3000</b>	0.18	958	1.0	<b>0.18</b>	<b>978</b>	B			B-C	B-C			26	5.6	11

**Motor Flanges Available**  
Flange Motore Disponibili

**B) Supplied with Reduction Bushing**  
Fornito con Bussola di Riduzione

**B) Available on Request without reduction bushing**  
Disponibile a Richiesta senza Bussola di Riduzione



**C) Motor Flange Holes Position**  
Posizione Fori Flangia Motore

**EN** Unit **15Q** is supplied without lubricant and equipped with a breather, level and drain plugs. User can add mineral oil keeping existing plugs. Should the user wish to fill it with synthetic oil, it is recommended to replace the existing plugs with a type that are closed. Gearbox **050** is supplied lubricated for life. See tab.1 for oils and recommended quantity. In tab.2 there are radial loads and axial loads applicable to the gearbox.

**I** Il riduttore tipo **15Q** è fornito privo di lubrificazione con tappi di sfiato, livello e scarico olio. L'utente può immettere olio minerale mantenendo i tappi esistenti. Se immetterà olio sintetico, dovrà sostituire i tappi esistenti con altri tipo chiuso. Il riduttore **050** è fornito lubrificato a vita con olio sintetico. Tab.1 per oli e quantità consigliati. Tab.2 carichi radiali e assiali applicabili al riduttore.

**D** Das Getriebe der Baugröße **15Q** wird ohne Schmiermittel geliefert. Es ist jedoch mit Einfüllschraube, Überdruckventil und Ablassschraube ausgerüstet. Das benötigte mineralische Öl kann über die Einfüllschraube eingefüllt werden. Sollte synthetisches Öl bevorzugt werden, so ist sind das eingebaute Überdruckventil durch eine geschlossenen Schraube zu ersetzen. Das Getriebe der Baugröße **050** ist lebensdauer geschmiert. In Tabelle 1 ist die Schmiermenge und das empfohlene Schmiermittel angegeben. In Tabelle 2 sind die zulässigen Radial - und Axialbelastungen des Getriebes aufgeführt.

**F** Le réducteur de type **15Q** est fourni sans lubrification et avec un bouchon de remplissage, de niveau et d'évacuation de l'huile. L'utilisateur peut y verser de l'huile minérale en conservant les bouchons existants. S'il y versera de l'huile synthétique, il devra substituer les bouchons existants avec d'autres bouchons de type fermé. Le réducteur de type **050** est fourni lubrifié à vie avec de l'huile synthétique. Voir tableau 1 concernant les huiles et les quantités conseillées. Voir tableau 2 concernant les charges radiales et axiales applicables au réducteur.

**E** El reductor tamaño **15Q** se suministra sin lubricante, provisto de tapones de respiración, nivel y descarga de aceite. El usuario puede utilizar aceite mineral, manteniendo los tapones existentes. Si prefiere utilizar aceite sintético deberá sustituir los tapones existentes por tapones ciegos. El reductor **050** se suministra lubricado de por vida con aceite sintético. Ver tabla 1, para cantidades y aceites recomendados. En la tabla 2, se encuentran las cargas radiales y axiales admitidas por el reductor.

B3	B6	B7	B8	V5	V6
2.0/0.14LT	1.35/0.14 LT	1.35/0.14 LT	2.0/0.14 LT	2.0/0.14 LT	2.0/0.14 LT
AGIP Blasias 460					

For all details on lubrication and plugs check our website  
Per maggiori dettagli su lubrificazione e tappi olio vedi il nostro sito web

tab. 1

#### RADIAL AND AXIAL LOADS

**Output shaft**  
Albero di uscita

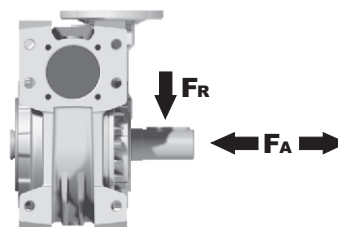

$n_2$ [min <sup>-1</sup> ]	FA [N]	FR [N]
25	1200	6000
15	1400	7000

**Input shaft**  
albero in entrata

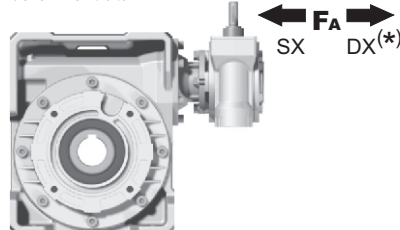

$n_1$ [min <sup>-1</sup> ]	FA [N]	FR [N]
1400	76	380

\*Strong axial loads in the DX direction are not allowed.  
Non sono consentiti forti carichi assiali con direzione DX

tab. 2

**P15QFB...** Basic wormbox  
Riduttore base

Gearbox weight  
peso riduttore **38.8 kg**

M. flanges	Kit code	øF	A
<b>63B5</b>	K050.4.041	138	78.5
<b>71B5</b>	K050.4.042	160	76
<b>80B5</b>	K050.4.043	200	76.5
<b>56B14</b>	KC40.4.049	80	76
<b>63B14</b>	K050.4.047	90	78.5
<b>71B14</b>	K050.4.045	105	76
<b>80B14</b>	K050.4.046	120	76.5

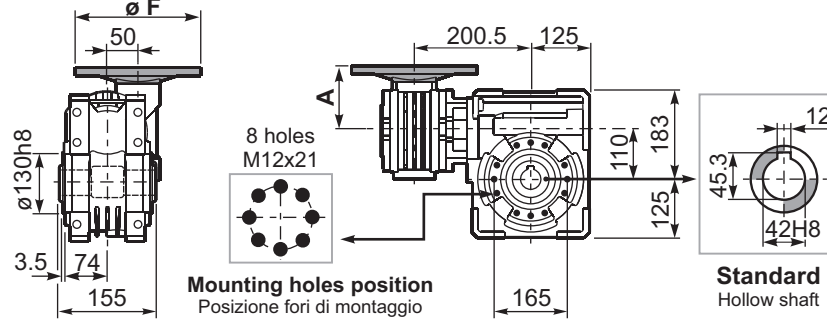

**P15QFC...** Output flange  
Flangia uscita

**P15QF1...** Output flange  
Flangia uscita

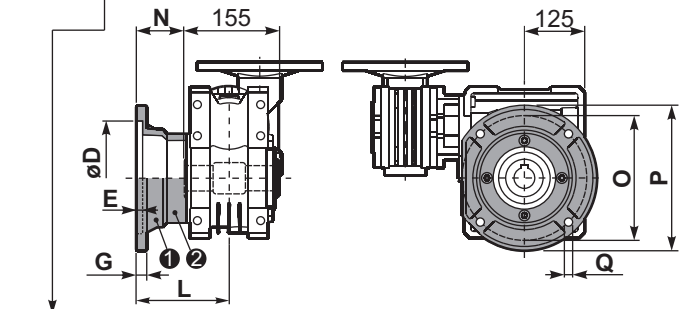
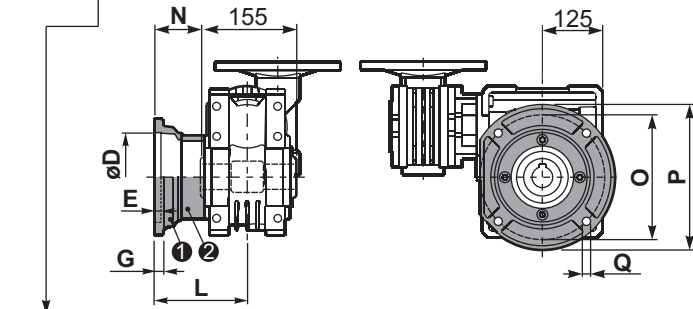

type B	øD	E	G	L	N	O	P	Q	kit code
<b>FC</b>	170 <sup>+0.083</sup> <sub>+0.043</sub>	11	16.5	131.5	54	230	270	13	① K110.9.010 ② -
<b>FL</b>	170 <sup>+0.083</sup> <sub>+0.043</sub>	11	16.5	179.5	102	230	270	13	① K110.9.011 ② -

type S	øD	E	G	L	N	O	P	Q	kit code
<b>F1</b>	180 <sup>+0.040</sup> <sub>0</sub>	5	18	150	72.5	215	250	15	① KS110.9.014 ② -
<b>F2</b>	170 <sup>+0.083</sup> <sub>+0.043</sub>	9.5	15	178	100.5	230	270	13	① KS110.9.012 ② -
<b>F3</b>	180 <sup>+0.040</sup> <sub>0</sub>	5	18	130	52.5	215	250	15	① KS110.9.013 ② -

**P15QFB...** Feet  
Piedi

**P15QBR...** Reaction arm  
Braccio di reazione

kit cod. K110.9.027

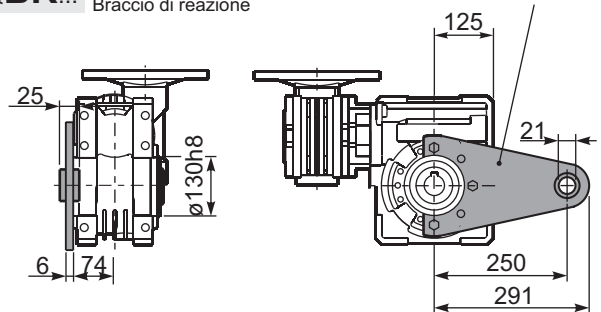
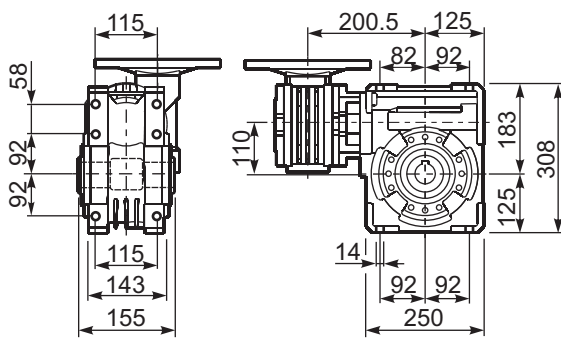

**R15QFB...** Input shaft  
Albero in entrata

**P15Q....S...** Single Shaft  
Albero lento semplice

**P15Q....D...** Double Shaft  
Albero lento bisp.

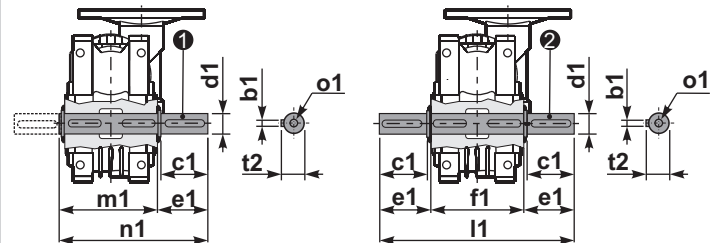
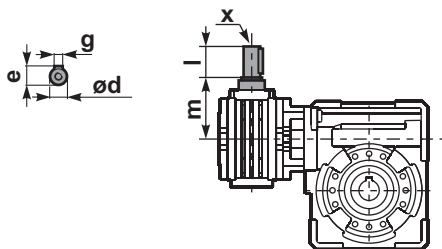

① kit cod. K110.5.028 type B    ② kit cod. K110.5.029 type B

	ød	e	g	l	m	x	kit code
type B	16 h6	18	5	30	79.5	M6x16	① K050.5.006 PAM71 ② K050.5.007 PAM80
type S	14 h6	16	5	30	79.5	M5x10	① KS050.5.008 PAM71 ② KS050.5.009 PAM80

	b1	c1	d1	e1	f1	l1	m1	n1	t2	o1
type B	12	75	42 <sup>-0.005</sup> <sub>-0.020</sub>	96.5	155	348	163.5	260	45	M12x32
type S	-	-	-	-	-	-	-	-	-	-

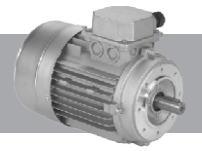

- 1) 230/400V - 50Hz three-phase asynchronous induction motor
- 2) Class F insulation
- 3) S1 duty
- 4) IP 55 protection
- 5) Not painted
- 6) Hard plastic sleeve to protect output shaft during the transportation

- 1) 230/400V - 50Hz motore trifase asincrono
- 2) Isolamento Classe F
- 3) S1 servizio continuo
- 4) Protezione IP 55
- 5) Non verniciato
- 6) Manicotto di protezione per l'albero motore

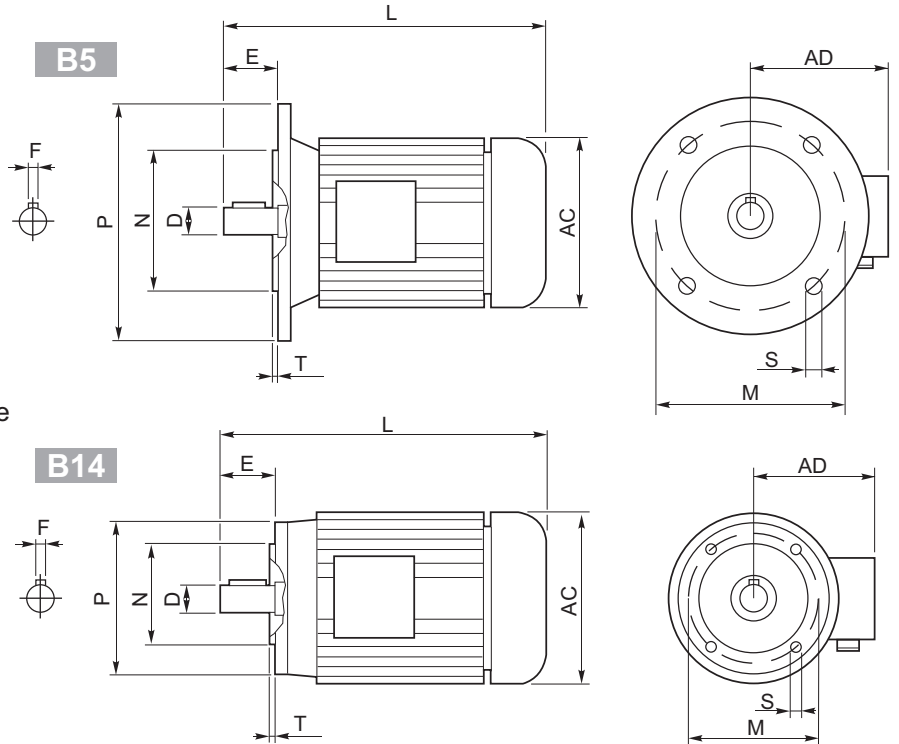

Outside dimensions and weight may be different according to manufacturers.  
 Le dimensioni esterne e il peso sono indicative, possono variare tra i vari costruttori.

	2 poli / poles			4 poli / poles			6 poli / poles			B5-B14					B5					B14					Kg	
	kW	Nm	A <sub>(400V)</sub>	kW	Nm	A <sub>(400V)</sub>	kW	Nm	A <sub>(400V)</sub>	D	F	E	L	AC	AD	N	M	P	S	T	N	M	P	S		T
56 A	0.09	0.32	0.38	0.06	0.44	0.27	—	—	—	9	3	20	199	108	96	80	100	120	7	2.5	50	65	80	M5	2.5	2.7
56 B	0.12	0.42	0.46	0.09	0.67	0.37	—	—	—	9	3	20	199	108	96	80	100	120	7	2.5	50	65	80	M5	2.5	2.9
63 A	0.18	0.63	0.60	0.12	0.84	0.50	0.09	0.99	0.57	11	4	23	208	120	99	95	115	140	9.5	3	60	75	90	M5	2.5	3.8
63 B	0.25	0.87	0.76	0.18	1.30	0.69	0.12	1.32	0.74	11	4	23	208	120	99	95	115	140	9.5	3	60	75	90	M5	2.5	4.2
71 A	0.37	1.30	1.00	0.25	1.70	0.91	0.18	1.90	0.80	14	5	30	-	130	104	110	130	160	9.5	3.5	70	85	105	M6	2.5	5.9
71 B	0.55	1.90	1.54	0.37	2.52	1.14	0.25	2.72	1.10	14	5	30	255	141	107	110	130	160	9.5	3.5	70	85	105	M6	2.5	6.5
80 A	0.75	2.60	1.85	0.55	3.77	1.51	0.37	3.84	1.18	19	6	40	296	159	127	130	165	200	11.5	3.5	80	100	120	M6	3	8.5
80 B	1.1	3.90	2.64	0.75	5.11	2.57	0.55	5.84	1.80	19	6	40	296	159	127	130	165	200	11.5	3.5	80	100	120	M6	3	10
90 S	1.5	5.00	3.31	1.1	7.45	2.78	0.75	7.92	2.32	24	8	50	-	170	135	130	165	200	11.5	3.5	95	115	140	M8	3	12.5
90 L	2.2	7.50	4.46	1.5	10.2	3.61	1.1	11.6	3.45	24	8	50	330	170	135	130	165	200	11.5	3.5	95	115	140	M8	3	15
100 LA	3.0	10.0	6.28	2.2	14.8	5.07	1.5	15.4	3.88	28	8	60	-	190	148	180	215	250	13	4	110	130	160	M8	3.5	20
100 LB	—	—	—	3.0	20.1	6.66	—	—	—	28	8	60	-	190	148	180	215	250	13	4	110	130	160	M8	3.5	22
112 M	4.0	13.4	8.10	4.0	26.7	8.55	2.2	22.6	5.30	28	8	60	381	210	164	180	215	250	13	4	110	130	160	M8	3.5	35
132 S	5.5	18.3	11.2	5.5	36.5	11.4	3.0	30.2	7.20	38	10	80	455	244	180	230	265	300	14	4	130	165	200	M10	4	41
	7.5	24.9	15.3																							51
132 M	—	—	—	7.5	49.4	15.0	4.0	40.0	9.13	38	10	80	500	244	180	230	265	300	14	4	130	165	200	M10	4	51
	9	61.4	18.5	51																						
160 M	—	—	—	11	72	21.5	—	—	—	42	12	110	613	335	246	250	300	350	18	5	—	—	—	—	—	79.2
160 L	—	—	—	15	98	29	—	—	—	42	12	110	657	335	246	250	300	350	18	5	—	—	—	—	—	97.5
180 M	—	—	—	18.5	121	35.5	—	—	—	48	14	110	712	366	266	250	300	350	19	5	—	—	—	—	—	170
180 L	—	—	—	22	144	42	—	—	—	48	14	110	712	366	266	250	300	350	19	5	—	—	—	—	—	170
200 L	—	—	—	30	196	53	—	—	—	55	16	110	780	405	341	300	350	400	19	5	—	—	—	—	—	240
225 S	—	—	—	37	240	69	—	—	—	60	18	140	888	463	360	350	400	450	19	5	—	—	—	—	—	305
225 M	—	—	—	45	292	84	—	—	—	60	18	140	888	463	360	350	400	450	19	5	—	—	—	—	—	310

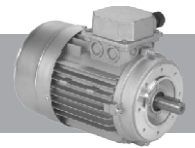

**Protection**

Standard IP55  
Please specify on purchase orders if you need a higher IP protection class.

**Grado di protezione**

IP55 Standard  
Specificare in sede di ordinazione per IP superiore.

**Schutzart**

IP55 Standard.  
Höheren IP Grad bitte im Auftrag angeben.

**Degré de protection**

IP55 standard.  
Au moment de la commande, spécifiez si vous souhaitez IP supérieur.

**Grado de protección**  
IP55 standard.  
Especificar en el pedido cuando necesiten protección IP superior.

**Insulation**

Standard CI.F  
To be specified upon placing the order if different insulation is required.

**Isolamento**

CI.F Standard  
Specificare in sede di ordinazione classe di isolamento diversa.

**Isolierung**

CI.F Standard.  
Davon abweichende Isolierungsklasse im Auftrag angeben.

**Isolement**

CI.F Standard.  
Au moment de la commande, spécifiez si vous souhaitez une classe d'isolement différente.

**Aislamiento**

CI.F standard.  
Especificar al efectuar el pedido la clase diferente de aislamiento.

Insulation / Isolamento Isolierung /Aislamiento		E	B	F	H
Max. temp.	C°	120°	130°	155°	175°
	F*	248°	266°	311°	347°

**Connections**

**Collegamenti**

**Verbindungselemente**

**Branchements**

**Conexiones**

Threephase asynchronous single polarity  
Asincrono trifase singola polarità  
Asynchronmotor 3-ph eine Drehzahl  
Moteur triphasé à une vitesse  
Asincrono trifasico de una velocidad

Threephase asynchronous double polarity  
Asincrono trifase doppia polarità  
Asynchronmotor 3-ph doppelte Drehzahl  
Moteur triphasé à deux vitesses  
Asincrono trifasico de dos velocidades

Single phase asynchronous  
Asincrono monofase  
Einphasen-Asynchronmotor  
Moteur monophasé  
Asincrono monofasico

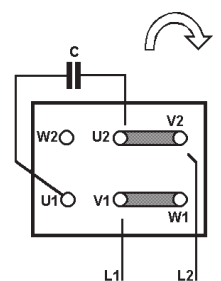
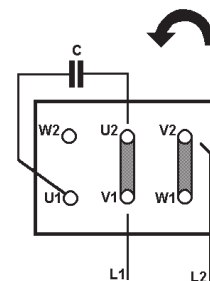
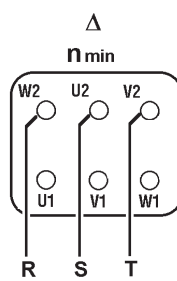
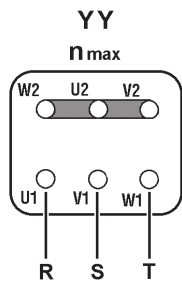
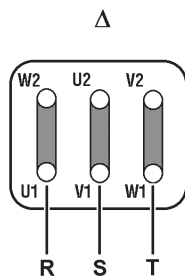
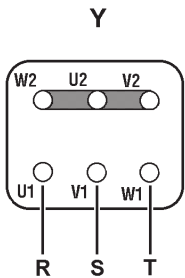

NOTES / NOTE / AUFZEICHNUNG / NOTAS

Lined area for writing notes.

**Please Read Carefully**

The following WARNING and CAUTION information is supplied to you for your protection and to provide you with many years of trouble free and safe operation of your product.

Read ALL instructions prior to operating reducer. Injury to personnel or reducer failure may be caused by improper installation, maintenance or operation.

**WARNING:**

- Written authorization is required to operate or use reducers in man lift or people moving devices.
- Check to make sure that certain applications do not exceed the allowable load capacities published in the current catalog.
- Buyer shall be solely responsible for determining the adequacy of the product for any and all uses to which Buyer shall apply the product. The application by Buyer shall not be subject to any implied warranty of fitness for a particular purpose.
- For safety, Buyer or User should provide protective guards over all shaft extensions and any moving apparatus mounted thereon. The User is responsible for checking all applicable safety codes in his area and providing suitable guards. Failure to do so may result in bodily injury and/or damage to equipment.
- Gearboxes operating in high position should have a protective shield for any possible parts falling down for casual accidents where people are moving under them.
- Hot oil and reducers can cause severe burns. Use extreme care when removing lubrication plugs and vents.
- Make certain that the power supply is disconnected before attempting to service or remove any components. Lock out the power supply and tag it to prevent unexpected application power.
- Reducers are not to be considered fail safe or self-locking devices. If these features are required, a properly sized, independent holding device should be utilized. Reducers should not be used as a brake.
- Any brakes that are used in conjunction with a reducer must be sized or positioned in such a way so as to not subject the reducer to loads beyond the catalog rating.
- Lifting supports including eyebolts are to be used for vertically lifting the gearbox only and not other associated attachments or motors.
- Use of an oil with an EP additive on units with backstops may prevent proper operation of the backstop. Injury to personnel, damage to the reducer or other equipment may result.
- Overhung loads subject shaft bearings and shafts to stress which may cause premature bearing failure and or shaft breakage from bending fatigue, if not sized properly.

**SELLING CONDITIONS**

Warranty for manufacturing defects will expire one-year the invoicing date. Hydro-Mec will replace or repair defective parts but will not accept any further changes for direct or indirect damages of any kind. The warranty will become null and void if repairs or changes are carried out without our prior written authorization.

**Our company will not be responsible for any direct or indirect damages, caused by a wrong use of the products or for not observing the catalogue/web indication**

**Leggere attentamente**

Le seguenti raccomandazioni sono fondamentali per la vostra protezione e per garantirvi molti anni di sicuro funzionamento del vostro prodotto senza alcun problema.

Leggere attentamente tutte le istruzioni prima di azionare il riduttore. L'inappropriata installazione, manutenzione o funzionamento del riduttore può causare incidenti al personale addetto e danni al riduttore stesso.

**ATTENZIONE:**

- E' richiesta autorizzazione scritta per azionare riduttori in ascensori o dispositivi per il movimento delle persone.
- Controllare che alcune applicazioni non eccedano la massima capacità di carico ammessa pubblicata in questo catalogo.
- L'acquirente è l'unico responsabile per la determinazione dell'adeguatezza del prodotto per qualcuna o tutte le utilizzazioni che l'acquirente stesso farà del riduttore. L'applicazione dell'acquirente non potrà essere soggetta ad alcuna implicita garanzia di montaggio per uno scopo particolare.
- Per ragioni di sicurezza l'acquirente dovrà provvedere a porre protezioni adeguate su tutta la lunghezza dell'albero a tutti gli organi in movimento. L'utilizzatore è responsabile del controllo di tutti i codici di sicurezza e la predisposizione di protezioni adeguate. In assenza di tali precauzioni si possono verificare incidenti alle persone e danni agli apparati.
- Su riduttori installati in posizioni elevate utilizzare protezioni adeguate per qualsiasi distacco accidentale di parti nel caso di passaggio di persone al di sotto.
- Olio e riduttori bollenti possono causare gravi ustioni. Usare estrema cautela nella rimozione dei tappi e delle ventole.
- Assicurarsi che la corrente di alimentazione sia scollegata prima di riparare o rimuovere alcun componente. Chiudere l'alimentazione e contrassegnare tale operazione per evitare accensioni accidentali.
- I riduttori non devono essere considerati esenti da guasti o a bloccaggio automatico. Se sono indispensabili queste caratteristiche, deve essere utilizzato un dispositivo indipendente della dimensione adatta. I riduttori non devono essere utilizzati come freni.
- Qualsiasi freno sia utilizzato insieme al riduttore deve essere della giusta grandezza e posizionato in modo da non causare carichi eccessivi non previsti dai dati forniti nel catalogo.
- I dispositivi di sollevamento come le golfare devono essere usati solo per sollevare verticalmente il riduttore e non altri dispositivi associati o motori.
- L'utilizzo di un olio con un additivo EP su gruppi provvisti di dispositivo di arresto possono inficiare l'uso corretto del freno e provocare danni alle persone, alle cose ed al riduttore stesso nonché ad altri apparecchi.
- I Carichi sospesi assoggettano i cuscinetti della vite e la vite stessa a sollecitazioni che possono causare, se non adeguatamente dimensionati, l'usura prematura dei cuscinetti e/o la rottura della vite a causa della resistenza alla flessione.

**CONDIZIONI DI VENDITA**

La garanzia relativa a difetti di costruzione ha la durata di un anno dalla data di fatturazione della merce. Tale garanzia comporta per Hydro-mec l'onere della sostituzione o riparazione delle parti difettose ma non ammette ulteriori addebiti per eventuali danni diretti o indiretti di qualsiasi natura.

La garanzia decade nel caso in cui siano state eseguite riparazioni o apportate modifiche senza nostro consenso scritto.

**La nostra ditta non si ritiene responsabile per eventuali danni diretti o indiretti derivanti da un uso improprio dei prodotti e dalla mancata osservanza delle indicazioni riportate a catalogo o web..**

# New options available

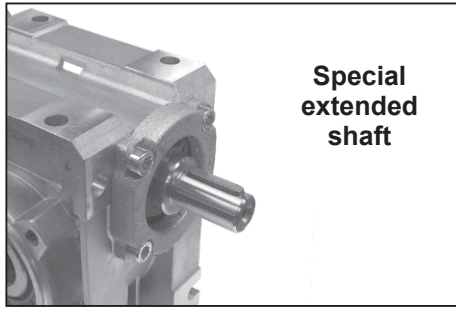

Special extended shaft

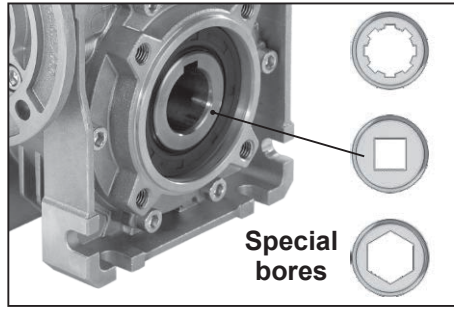

Special bores

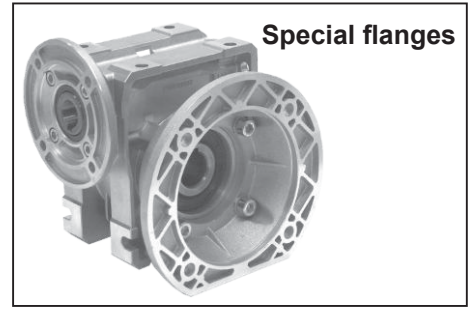

Special flanges

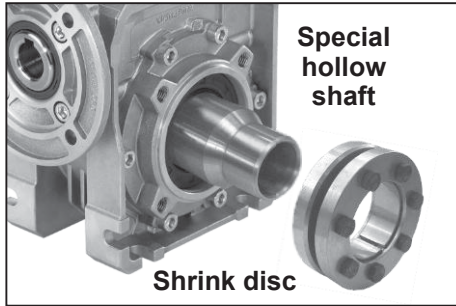

Special hollow shaft

Shrink disc

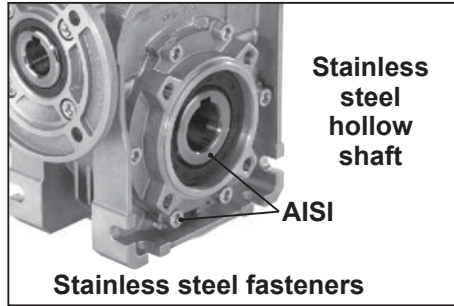

Stainless steel hollow shaft

Stainless steel fasteners

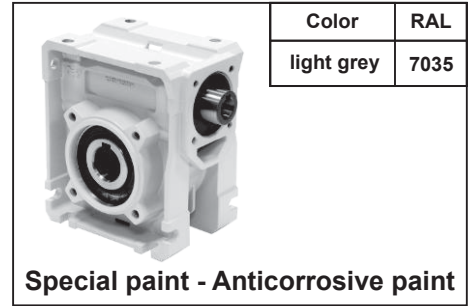

Color	RAL
light grey	7035

Special paint - Anticorrosive paint

## Others HYDRO-MEC products



Worm gearboxes  
Rid. a vite senza fine



Stainless steel worm gearboxes  
Rid. a vite senza fine Inox

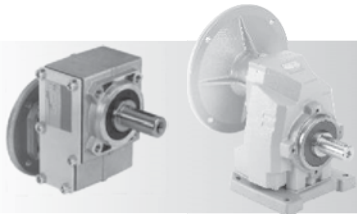

One step gearboxes  
Riduttori ad uno stadio

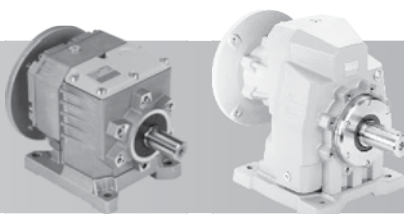

Coaxial gearboxes  
Riduttori coassiali

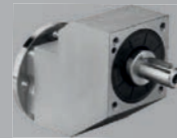

Stainless steel one step gearbox  
Riduttore uno stadio Inox

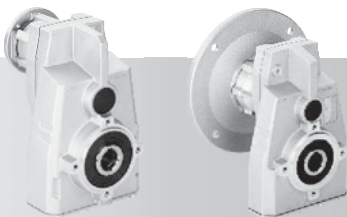

Shaft mounted gearboxes  
Riduttori pendolari

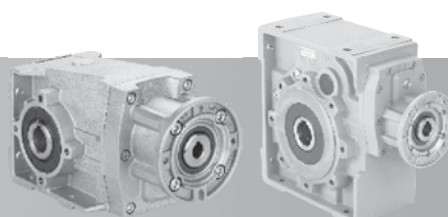

Helical bevel gearboxes  
Rid. a coppia conica

## Distributed From:

### HYDRO-MEC

Via della tecnica, 19  
36050 SOVIZZO (VI) ITALY  
Tel.: +39 0444 551911  
Fax: +39 0444 536139  
e-mail: [hydromec@hydromec.com](mailto:hydromec@hydromec.com)  
Website: [www.hydromec.com](http://www.hydromec.com)

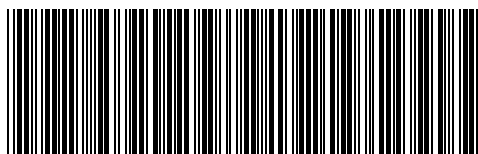

\* CT- VFM- Q- HM0 1 5