

radicon

with you at every turn

Series M Helical In-Line

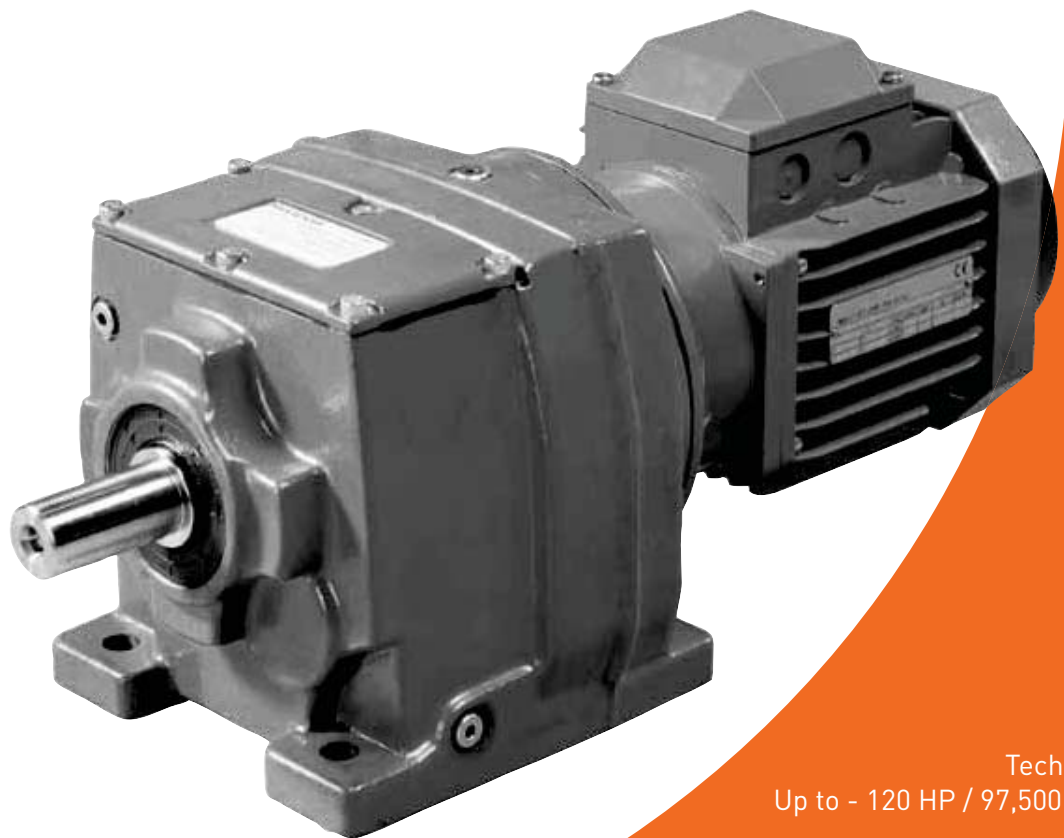

Technical
Up to - 120 HP / 97,500 lb.in

Geared Motors
CM-2.00US1211

PRODUCTS IN THE RANGE

Serving an entire spectrum of mechanical drive applications from food, energy, mining and metal; to automotive, aerospace and marine propulsion, we are here to make a positive difference to the supply of drive solutions.

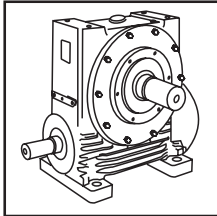

Series A
Worm Gear units
and geared motors
in single & double
reduction types

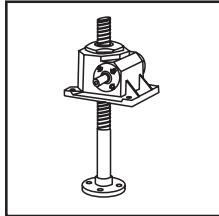

Series BD
Screwjack worm
gear unit

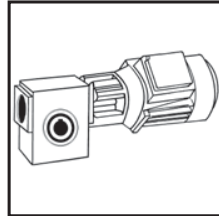

Series BS
Worm gear unit

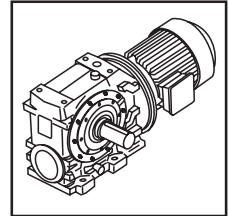

Series C
Right angle drive
helical worm geared
motors & reducers

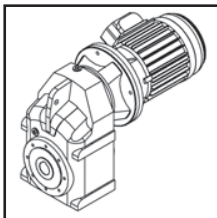

Series F
Parallel angle helical
bevel helical geared
motors & reducers

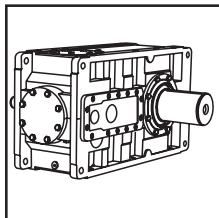

Series G
Helical parallel shaft
& bevel helical right
angle drive gear
units

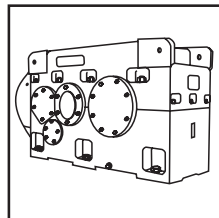

Series H
Large helical parallel
shaft & bevel helical
right angle drive units

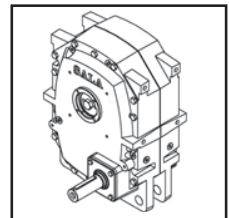

Series J
Shaft mounted
helical speed
reducers

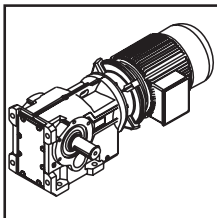

Series K
Right angle helical
bevel helical geared
motors & reducers

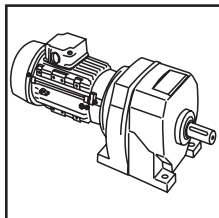

Series M
In-line helical geared
motors & reducers

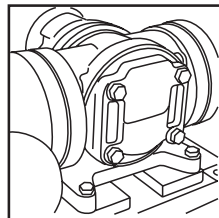

Roloid Gear Pump
Lubrication and fluid
transportation pump

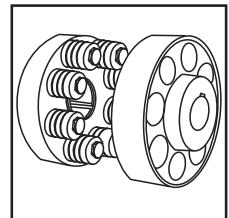

**Series X
Cone Ring**
Pin and bush
elastomer coupling

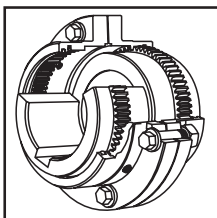

**Series X
Gear**
Torsionally rigid,
high torque coupling

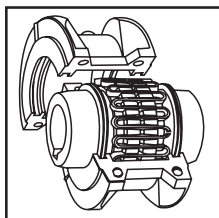

**Series X
Grid**
Double flexing steel
grid coupling

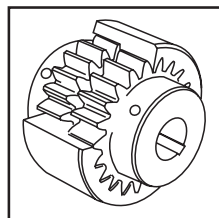

**Series X
Nylicon**
Gear coupling with
nylon sleeve

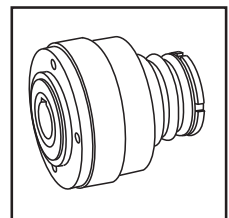

**Series X
Torque Limiter**
Overload protection
device



We offer a wide range of repair services and many years experience of repairing demanding and highly critical transmissions in numerous industries.

We can create custom engineered transmission solutions of any size and configuration.

SERIES M

CONTENTS

General Description _____	1
Unit Designations _____	2
Explanation and use of Ratings and Service Factors _____	3
Load Classification by Applications _____	4
Selection Procedure For Motorized Units _____	5 - 6
Output Options _____	7 - 8
Motor Adaptors _____	9 - 12
Lubrication _____	13
Mounting Positions _____	14
MOTORIZED	
Motor Details _____	16
Additional Motor Features _____	17
Additional Gearbox Features _____	18
Selection Tables Geared Motors _____	19 - 51
Dimension Sheets - Geared Motors _____	52 - 59
Motorized Backstop Module _____	60
REDUCER	
Overhung & Axial Loads on Shafts _____	62
Reduction Ratings _____	63 - 73
Dimension Sheets - Geared Motors _____	74 - 82
Thermal Power Ratings _____	83
Fan Cooled Units _____	84
Reducer Backstop Module _____	85
Shipping Specification _____	86 - 87

SERIES M

GENERAL DESCRIPTION

Series M inline geared motors and reducers provide a very efficient and compact drive solution to meet most requirements up to 90kW with maximum output torque capacity of 11000Nm.

The range takes advantage of many years of accumulated design expertise, together with the use of high quality materials and components. The end result is a series of speed reducing and geared motors offering high load carrying capacity, high efficiency, quiet running and reliability.

The Range Includes

Twelve sizes of unit with a ratio coverage of 1.4/1 to 70/1 in double reduction and up to 250/1 in triple reduction and 16200/1 in combined units.

Unit Versions Available

- Base Mounted
 - B5 (D) Flange Mounted
 - B14 (C) Flange Mounting
 - Base Mount and B14 (C) Flange Mounting
- Unit type M - Motorized with IEC standard motor
 Unit type N - Motorized with NEMA standard motor
 Unit type H - Motorized with IEC high efficiency motor (IE2 or EPACT)
 Unit type E - Motorized with NEMA high efficiency motor (EPACT)
 Unit type G - Unit to allow fitting of a standard IEC motor
- Unit type A - Unit to allow fitting of NEMA motor
- Unit type R - Reducer unit
 Unit type S - Reducer unit with fan kit
 Unit type W - Reducer unit with backstop CCW rotation
 Unit type X - Reducer unit with backstop CW rotation
 Unit type Y - Reducer unit with fan and backstop CW rotation
 Unit type Z - Reducer unit with fan and backstop CCW rotation

Design Features Include

- Patented standard motor connection (IEC or NEMA).
- Ability to fit double oil seal input and output as required.
- All units being suitable to fit IEC or NEMA standard motors.
- All units are dimensionally interchangeable with other major manufacturers.
- Brake geared motors are available as standard.
- Sizes 01, 02, 03, 04, 05, 06 and 07 are all supplied with lubricant.
- Sizes 08, 09, 10, 13 and 14 are supplied without lubricant.
- Motorized units can be fitted with a backstop module and reducer units can be fitted with a backstop and fan.

As improvements in design are being made continually this specification is not to be regarded as binding in detail and drawings and capacities are subject to alteration without notice. Certified drawings will be sent on request.

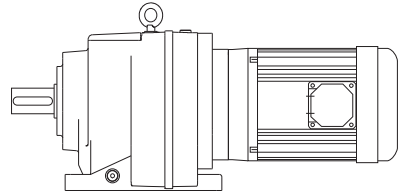

Two stage base mounted motorized

*

M	0	3	2	2	8	.	0	B	M	C	-	1	A	.	7	5	A	-	-
---	---	---	---	---	---	---	---	---	---	---	---	---	---	---	---	---	---	---	---

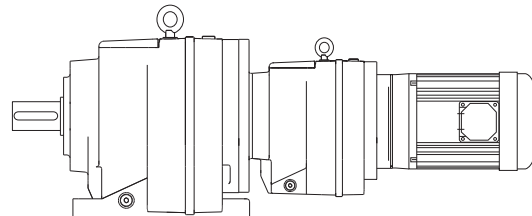

Four stage base mounted motorized

*

M	0	6	4	2	2	5	0	B	M	C	-	1	A	.	1	8	A	-	-
---	---	---	---	---	---	---	---	---	---	---	---	---	---	---	---	---	---	---	---

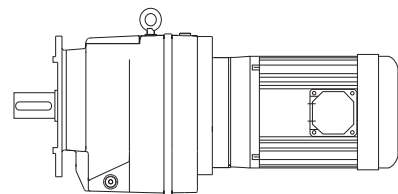

Three stage flange mounted motorized

*

M	0	6	3	2	1	2	5	L	M	C	-	1	A	.	7	5	A	-	-
---	---	---	---	---	---	---	---	---	---	---	---	---	---	---	---	---	---	---	---

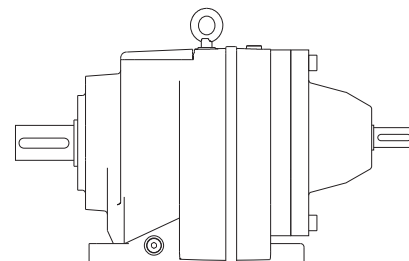

Two stage base mounted reducer

*

M	0	7	2	2	7	1	.	B	R	C	-	1	-	-	-	-	-	-	-
---	---	---	---	---	---	---	---	---	---	---	---	---	---	---	---	---	---	---	---

* Typical unit designations

SERIES M

UNIT DESIGNATIONS

Gearbox Codes										Motor Codes										
Series	Size of Unit			No of Reductions		Revision Version		Nominal Overall Ratio		Unit Version	Type of Unit	Output Shaft	Motor Adaptor	Mounting Position		Geared Motor Power		No of Motor Poles	Additional Motor Features	Additional Gearbox Features
1	2	3	4	5	6	7	8	9	10	11	12	13	14	15	16	17	18	19	20	
M																				
M	0	3	2	2	8	.	0	B	M	C	-	1	A	.	7	5	A	-	-	

Example

1 - Series M

Range **M**

2, 3 - Size of Unit

0 1 Through **1 4**

4 - No of Reductions

2 Through **5**

5 - Revision Version

2 For Sizes 01 to 08

1 For Sizes 09 to 14

6, 7, 8 - Nominal Overall Ratio

eg **8 . 0**

9 - Unit Version

B - Base Mounted

B5 (D) Flange Mounted

E -B14 (C) Flange Mounting

V - Base and B14 (C) Flange Mounting

(Non - Standard Special Orders Only)

Letter Entry Depends on Flange Diameter

10 - Type of Unit

M - Motorized with IEC standard motor (IE2)

N - Motorized with NEMA standard motor (EPACT)

H - Motorized with IEC high efficiency motor (IE3)

E - Motorized with NEMA high efficiency motor (PREMIUM)

G - Unit to allow fitting of IEC motor (customer own motor)

A - Unit to allow fitting of NEMA motor (customer own motor)

R - Reducer unit

S - Reducer unit with fan kit

W - Reducer unit with backstop CCW rotation

X - Reducer unit with backstop CW rotation

Y - Reducer unit with fan and backstop CW rotation

Z - Reducer unit with fan and backstop CCW rotation

20 - Additional Gearbox Features

Double Oil Seal, Motorized Backstop Etc

eg **- F**

19 - Additional Motor Features

eg **- A**

For Types Without Motor

Enter **-**

18 - No of Motor Poles

- No motor

	50 Hz		60 Hz	
4 Pole (Std) 1500 rpm	A	1800 rpm	B	
4 Pole (High)1500 rpm	K	1800 rpm	L	
6 Pole (Std) 1000 rpm	C	1200 rpm	D	
6 Pole (High)1000 rpm	M	1200 rpm	N	
2 Pole 3000 rpm	E	3600 rpm	F	
8 Pole 750 rpm	G	900 rpm	H	

S Dual speed or special motor

15, 16, 17 - Geared Motor Powers

Motor Power Required

eg **. 7 5**

For reducer and non standard

motor types enter **- - -**

13, 14 - Mounting Position

eg **2 B**

12 - Motor Adaptor For Unit Types

Column 10 Entries M, N, H, E, G or A

For All Other Types Enter **-**

11 - Output Shaft

N - Inch

C - Standard

* This Page May Be Photocopied Allowing The Customer To Enter Their Order
To access the on line configurator please visit www.radicon.com

SERIES M

EXPLANATION & USE OF RATINGS & SERVICE FACTORS

Gear unit selection is made by comparing actual loads with catalogue ratings. Catalogue ratings are based on a standard set of loading conditions, whereas actual load conditions vary according to type of application. Service Factors are therefore used to calculate an equivalent load to compare with catalogue ratings.

i.e. Equivalent Load = Actual Load x Service Factor

Mechanical ratings and service factors Fm and Fs

Mechanical ratings measure capacity in terms of life and/or strength, assuming 10 hr/day continuous running under uniform load conditions.

Catalogue ratings allow 100% overload at starting, braking or momentarily during operation up to 10 hours per day.

The unit selected must therefore have a catalogue rating at least equal to half maximum overload.

Mechanical Service Factor Fm (Table 1) is used to modify the actual load according to daily operating time, and type of loading.

Load characteristics for a wide range of applications are detailed in Table 3 opposite, which are used in deciding the appropriate Service Factor Fm from Table 1.

If overloads can be calculated, or accurately assessed, actual loads should be used instead of Fm.

For units subjected to frequent stop/starts overloads in excess of 10 times/day multiply factor Fm x Factor Fs (table 2).

For applications where units are to operate in extremely dusty or moist/humid atmospheres unit selection should be referred to our application engineers.

Table 1. Mechanical Service Factor (Fm)

Prime mover	Duration of service-hrs per day	Load classification-driven machine		
		Uniform mass acceleration factor ≤ 0.2	Moderate mass acceleration factor ≤ 3	Heavy mass acceleration factor ≤ 10
Electric motor, steam turbine or hydraulic motor	Under 3	0.80	1.00	1.50
	3 to 10	1.00	1.25	1.75
	Over 10	1.25	1.50	2.00
Multi-cylinder internal combustion engine	Under 3	1.00	1.25	1.75
	3 to 10	1.25	1.50	2.00
	Over 10	1.50	1.75	2.25
Single cylinder internal combustion engine	Under 3	1.25	1.50	2.00
	3 to 10	1.50	1.75	2.25
	Over 10	1.75	2.00	2.50

$$\text{Mass acceleration factor} = \frac{\text{all external moments of inertia}^*}{\text{moment of inertia of driving motor}}$$

* calculated with reference to the motor speed

Table 2. Number of Starts Factor (Fs)

Start / Stops per hour (1)	Up to 1	5	10	40	60	≥ 200
Factor Fs	1.00	1.03	1.06	1.10	1.15	1.20

Note: (1) Intermediate values are obtained by linear interpolation

SERIES M

LOAD CLASSIFICATION BY APPLICATIONS

Table 3

U = Uniform load

M = Moderate shock load

H = Heavy shock load

† = Refer to
Application Engineering

Driven Machine	type of load	Driven Machine	type of load	Driven Machine	type of load
Cranes		log haul-incline	H	log haul	H
main hoists	I	log haul-well type	H	presses	M
bridge travel	I	log turning device	H	pulp machine reel	M
trolley travel	I	main log conveyor	H	stock chest	M
		off bearing rolls	M	suction roll	M
Crusher		planer feed chains	M	washers and thickeners	M
ore	H	planer floor chains	M	winders	M
stone	H	planer tilting hoist	M		
sugar	H	re-saw merry-go-round		Printing presses	I
		conveyor	M		
Dredges		roll cases	H	Pullers	
cable reels	M	slab conveyor	H	barge haul	H
conveyors	M	small waste			
cutting head drives	H	conveyor-belt	U	Pumps	
jig drives	H	small waste		centrifugal	U
maneuvering winches	M	conveyor-chain	M	proportioning	M
pumps	M	sorting table	M	reciprocating	
screen drive	H	tipple hoist conveyor	M	single acting; 3 or	
stackers	M	tipple hoist drive	M	more cylinders	M
utility winches	M	transfer conveyors	M	double acting; 2 or	
		transfer rolls	M	more cylinders	M
Dry dock cranes		tray drive	M	single acting; 1 or 2	
main hoist	I	trimmer feed	M	cylinders	I
auxiliary hoist	I	waste conveyor	M	double acting; single	
boom, luffing	I			cylinder	I
rotating, swing or slew	I	Machine tools		rotary	
tracking, drive wheels	I	bending roll	M	gear type	U
		punch press-gear driven	H	lobe, vane	U
		notching press- belt			
		driven	I	Rubber and plastics	
		plate planers	H	industries	
Elevators		tapping machine	H	crackers	
bucket-uniform load	U	other machine tools		laboratory equipment	M
bucket-heavy load	M	main drives	M	mixed mills	H
bucket-continuous	U	auxiliary drives	U	refiners	M
centrifugal discharge	U			rubber calenders	M
escalators	U	Metal mills		rubber mill-2 on line	M
freight	M	draw bench carriage		rubber mill-3 on line	M
gravity discharge	U	and main drive	M	sheeter	I
man lifts	U	pinch, dryer and		tire building machines	I
passenger	I	scrubber rolls-reversing	I	tire and tube press	
		slitters	M	openers	I
Fans		table conveyors		tubers and strainers	M
centrifugal	U	non-reversing		warming mills	M
cooling towers		group drives	M		
induced draft	I	individual drives	H	Sand muller	M
forced draft	I	reversing			
induced draft	M	wire drawing and		Sewage disposal	
large, mine, etc	M	flattening machine	M	equipment	
large, industrial	M	wire winding machine	M	bar screens	U
light, small diameter	U			chemical feeders	U
		Mill-rotary type		collectors	U
Feeders		ball		dewatering screws	M
apron	M	cement kilns	H	scum breakers	M
belt	U	dryers and coolers	H	slow or rapid mixers	M
disc	U	kilns, other than cement	H	thickeners	M
reciprocating	H	pebble	H	vacuum filters	M
screw	M	rod			
		plain	H	Screens	
Food industry		wedge bar	H	air washing	U
beef slicer	M	tumbling barrels	H	rotary-stone or gravel	M
cereal cooker	U			travelling water intake	U
dough mixer	M	Mixers			
meat grinders	M	concrete mixers		Slab pushers	M
		-continuous	M		
Generators-not		concrete mixers		Steering gear	I
welding	U	-intermittent	M		
		constant density	U	Stokers	U
Hammer mills	H	variable density	M		
		Oil industry		Sugar industry	
Hoists		chillers	M	cane knives	M
heavy duty	H	oil well pumping	I	crushers	M
medium duty	M	paraffin filter press	M	mills	M
skip hoist	M	rotary kilns	M		
		Paper mills		Textile industry	
Laundry washers		agitators, (mixers)	M	batchers	M
reversing	M	barker-auxiliaries-		calenders	M
		hydraulic	M	cards †	M
Laundry tumblers	M	barker-mechanical	H	dry cans	M
		barking drum	H	dryers	M
		beater and pulper	M	dyeing machinery	M
Line shafts		bleacher	U	knitting machines	I
driving processing		calenders	M	looms	M
equipment	M	calenders-super	H	mangles	M
light	U	converting machine,		nappers	M
other line shafts	U	except cutters, platers	M	pads	M
		conveyors	U	range drives	I
Lumber industry		couch	M	slashers	M
barkers-hydraulic-		cutters-plates	H	soapers	M
mechanical	M	cylinders	M	spinners	M
burner conveyor	M	dryers	M	tenter frames	M
chain saw and drag saw	H	felt stretcher	M	washers	M
chain transfer	H	felt whipper	H	winders	M
craneway transfer	H	jordans	M		
de-barking drum	H			Windlass	I
edger feed	M				
gang feed	M				
green chain	M				
live rolls	H				
log deck	H				

SERIES M

SELECTION PROCEDURE FOR MOTORIZED UNITS

EXAMPLE APPLICATION DETAILS

Absorbed power of driven machine = 0.95 HP
 Output speed of gearbox or Input speed of machine = 54 rev/min
 Application = Uniformly loaded belt conveyor
 Duration of service (hours per day) = 24hrs
 Mounting position = 1
 Ambient temperature = 70°F
 Running time (%) = 100%

2 DETERMINE REQUIRED OUTPUT TORQUE AT GEARBOX OUTPUTSHAFT

$$\text{Absorbed output torque} = \frac{\text{Absorbed power} \times 9550}{\text{Gearbox output speed}}$$

$$\frac{0.95 \times 63025}{54} = 1109 \text{ lb.in}$$

1 DETERMINE MECHANICAL SERVICE FACTOR (Fm)

Refer to Load Classification by Application, table 3, page 4

Application = Uniformly loaded belt conveyor

Conveyors-uniformly loaded or fed	
apron	U
assembly	U
belt	U
bucket	U
chain	U

U = Uniform load

Refer to mechanical service factor (Fm), table 1, page 3

Duration of service (hours per day) = 24hrs

Prime mover	Duration of service-hrs per day	Load classification-drive	
		Uniform	Moderate
Electric motor, steam turbine or hydraulic motor	Under 3	0.80	1.00
	3 to 10	1.00	1.25
	Over 10	1.25	1.50

Therefore mechanical service factor (Fm) = 1.25

If the unit is subject to frequent start/stops Fm must be multiplied by factor Fs (see table 2 page 3)

3 SELECT GEARED MOTOR

Refer to selection table one motor size larger than absorbed power. Absorbed power = 0.95 HP, therefore refer to 1.0 HP selection table.

Always select from 4 POLE selection table in the first instance as this offers a more economical solution.

Required output speed of gearbox = 54 rev/min

1.0 HP	N2 R/MIN	i	M2 lb.in	Fm	lb	UNIT DESIGNATION	lb	
	Output Speed	Ratio	Output Torque	Service Factor	Overhung Load	Column Entry 1 Through 20 Spaces to be filled when entering order	Weight of Base Mount Unit	Motor Frame Size
	188	9.09	324	3.71	899	M 0 2 2 2 9 . 0 _ M _ _ _ 1 . 0 B - -	49.6	80A
	138	12.37	441	2.89	899	1 2 .		
	122	14.05	500	2.60	899	1 4 .		
	107	15.97	567	2.40	899	1 6 .		
	97	17.58	626	2.19	899	1 8 .		
	85	20.23	719	1.97	899	2 0 .		
	78	21.99	782	1.81	899	2 2 .		
	65	26.40	938	1.51	899	2 8 .		
	54	31.68	1123	1.26	899	3 2 .		
	48	35.69	1263	1.12	899	3 8 .		

4 CHECK OUTPUT TORQUE

Output torque (M2) of selected unit must be equal or more than required output torque at gearbox outputshaft.

Required output torque at gearbox outputshaft = 1109 lb.in

1.0 HP	N2 R/MIN	i	M2 lb.in	Fm	lb	UNIT DESIGNATION	lb	
	Output Speed	Ratio	Output Torque	Service Factor	Overhung Load	Column Entry 1 Through 20 Spaces to be filled when entering order	Weight of Base Mount Unit	Motor Frame Size
	188	9.09	324	3.71	899	M 0 2 2 2 9 . 0 _ M _ _ _ 1 . 0 B - -	49.6	80A
	138	12.37	441	2.89	899	1 2 .		
	122	14.05	500	2.60	899	1 4 .		
	107	15.97	567	2.40	899	1 6 .		
	97	17.58	626	2.19	899	1 8 .		
	85	20.23	719	1.97	899	2 0 .		
	78	21.99	782	1.81	899	2 2 .		
	65	26.40	938	1.51	899	2 8 .		
	54	31.68	1123	1.26	899	3 2 .		
	48	35.69	1263	1.12	899	3 8 .		

Selected unit's output torque (M2) = 1123 lb.in, therefore unit is acceptable

Go to point 5

SERIES M

SELECTION PROCEDURE FOR MOTORIZED UNITS

5 CHECK SERVICE FACTOR

Service factor (Fm) of selected unit must be equal or more than required service factor.

Required service factor of gearbox = 1.25

1.0 HP	N2 R/MIN	i	M2 lb.in	Fm	lb	UNIT DESIGNATION	lb	
	Output Speed	Ratio	Output Torque	Service Factor	Overhung Load	Column Entry <input type="text" value="1"/> Through <input type="text" value="20"/> Spaces to be filled when entering order	Weight of Base Mount Unit	Motor Frame Size
	188	9.09	324	3.71	899	M 0 2 2 2 9 . 0 _ M _ _ _ _ 1 . 0 B - -	49.6	80A
	138	12.37	441	2.89	899	1 2 .		
	122	14.05	500	2.60	899	1 4 .		
	107	15.97	567	2.40	899	1 6 .		
	97	17.58	626	2.19	899	1 8 .		
	85	20.23	719	1.97	899	2 0 .		
	78	21.99	782	1.81	899	2 2 .		
	65	26.40	938	1.51	899	2 8 .		
	54	31.68	1123	1.26	899	3 2 .		
	48	35.69	1263	1.12	899	3 8 .		

Selected unit's service factor (Fm) = 1.26, therefore unit is acceptable.

Alternatively a M03 unit could be selected which has a greater service factor

1.0 HP	N2 R/MIN	i	M2 lb.in	Fm	lb	UNIT DESIGNATION	lb	
	Output Speed	Ratio	Output Torque	Service Factor	Overhung Load	Column Entry <input type="text" value="1"/> Through <input type="text" value="20"/> Spaces to be filled when entering order	Weight of Base Mount Unit	Motor Frame Size
	153	11.15	398	3.78	899	M 0 3 2 2 1 1 . _ M _ _ _ _ 1 . 0 B - -	49.6	80A
	138	12.37	441	3.53	899	1 2 .		
	122	14.05	499	3.24	899	1 4 .		
	107	15.97	569	3.02	799	1 6 .		
	97	17.58	626	2.78	779	1 8 .		
	85	20.23	720	2.53	745	2 0 .		
	78	21.99	783	2.36	859	2 2 .		
	65	26.40	940	1.97	810	2 8 .		
	54	31.68	1119	1.65	696	3 2 .		
	48	35.69	1258	1.47	766	3 8 .		

Selected unit's service factor (Fm) = 1.65, therefore unit is acceptable.

6 CHECK OVERHUNG LOADS

If sprocket, gear, etc is mounted on the outputshaft then refer to Overhung Loads Procedure, page 62, and compare with allowable overhung load (lb) of selected unit

Allowable overhung load (lb) must be equal or more than calculated overhung load (P)

1.0 HP	N2 R/MIN	i	M2 lb.in	Fm	lb	UNIT DESIGNATION	lb	
	Output Speed	Ratio	Output Torque	Service Factor	Overhung Load	Column Entry <input type="text" value="1"/> Through <input type="text" value="20"/> Spaces to be filled when entering order	Weight of Base Mount Unit	Motor Frame Size
	188	9.09	324	3.71	899	M 0 2 2 2 9 . 0 _ M _ _ _ _ 1 . 0 B - -	49.6	80A
	138	12.37	441	2.89	899	1 2 .		
	122	14.05	500	2.60	899	1 4 .		
	107	15.97	567	2.40	899	1 6 .		
	97	17.58	626	2.19	899	1 8 .		
	85	20.23	719	1.97	899	2 0 .		
	78	21.99	782	1.81	899	2 2 .		
	65	26.40	938	1.51	899	2 8 .		
	54	31.68	1123	1.26	899	3 2 .		
	48	35.69	1263	1.12	899	3 8 .		

NOTE: If any of the following conditions occur then consult Application Engineering:-

- Mass acceleration factor > 10
- Ambient temperature is above 104°F (40°C)

SERIES M

UNIT VERSIONS

UNIT VERSIONS, COLUMN 9 ENTRY

B

- Base Mounted

E

- Flange mount with B14 (C) Flange Mounting (For sizes M01 to M08 only)

V

- Base mount with B14 (C) Flange Mounting (Only available as standard for single reduction units, other units can be supplied as special units)

Flange Mounted

Letter Entry Depends on Flange Diameter See tables below

Flange Diameter	Column 9 Entry	Flange Diameter	Column 9 Entry
4.72	H	11.81	Y
5.51	J	13.78	Z
6.30	K		
7.87	L		
9.84	N		

Base and Flange Mounted

Letter Entry Depends on Flange Diameter See tables below

Flange Diameter	Column 9 Entry	Flange Diameter	Column 9 Entry
4.72	S	11.81	Y
5.51	T	13.78	Z
6.30	U		
7.87	W		
9.84	X		

Unit Size				Flange Dia	Column 9 Entry
Double	Triple	Quadruple	Quintuple		
M0122	M0132	-	-	4.72	H
				5.51	J
				6.30	K
				7.87	L
M0222	M0232	-	-	4.72	H
				5.51	J
				6.30	K
				7.87	L
M0322	M0332	M0342	M0352	4.72	H
				5.51	J
				6.30	K
M0422	M0432	M0442	M0452	7.87	L
				9.84	N
				5.51	J
				6.30	K
M0522	M0532	M0542	M0552	7.87	L
				9.84	N
				5.51	J
				6.30	K
M0622	M0632	M0642	M0652	7.87	L
				9.84	N
				11.81	P
M0722	M0732	M0742	M0752	7.87	L
				9.84	N
				11.81	P
M0822	M0832	M0842	M0852	11.81	P
				13.78	R
M0921	M0931	M0941	M0951	17.72	F
M1021	M1031	M1041	M1051	17.72	F
M1321	M1331	M1341	M1351	21.65	G
M1421	M1431	M1441	M1451	21.65	G

Unit Size				Flange Dia	Column 9 Entry
Double	Triple	Quadruple	Quintuple		
M0122	M0132	-	-	4.72	S
				5.51	T
				6.30	U
				7.87	W
M0222	M0232	-	-	4.72	S
				5.51	T
				6.30	U
				7.87	W
M0322	M0332	M0342	M0352	4.72	S
				5.51	T
				6.30	U
M0422	M0432	M0442	M0452	7.87	W
				9.84	X
				5.51	T
				6.30	U
M0522	M0532	M0542	M0552	7.87	W
				9.84	X
				5.51	T
				6.30	U
M0622	M0632	M0642	M0652	7.87	W
				9.84	X
				11.81	Y
M0722	M0732	M0742	M0752	7.87	W
				9.84	X
				11.81	Y
M0822	M0832	M0842	M0852	11.81	Y
				13.78	Z
M0921	M0931	M0941	M0951	17.72	-
M1021	M1031	M1041	M1051	17.72	-
M1321	M1331	M1341	M1351	21.65	-
M1421	M1431	M1441	M1451	21.65	-

SERIES M

OUTPUT SHAFT OPTIONS

OUTPUTSHAFT OPTIONS

* Inch shaft has an open ended keyway, therefore no 'L11' dimension is required.

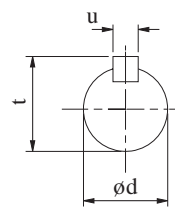
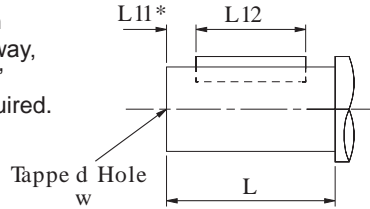

Column 11 Entry

- C Standard
- N Inch

OUTPUTSHAFT OPTIONS - double, triple, quadruple and quintuple reduction

SIZE OF UNIT	TYPE OF OUTPUTSHAFT	COLUMN 11 ENTRY	DIMENSIONS IN INCHES (Standard metric shaft in mm)						
			ød	L	L11	L12	t	u	w
01	Inch *	N	0.7500"/0.7495"	1.575"	-	19/32"	0.829"	3/16"	1/4" UNF x 0.63" deep
	Standard	C	20.015 / 20.002	40	4	32	22.5	6	M6 x 1, 16 deep
02	Inch *	N	1.0000"/0.9995"	1.969"	-	19/16"	1.106"	1/4"	1/4" UNF x 0.71" deep
	Standard	C	25.015 / 25.002	50	4	40	28	8	M10 x 1.5, 22 deep
03	Inch *	N	1.0000"/0.9995"	1.969"	-	19/16"	1.106"	1/4"	1/4" UNF x 0.71" deep
	Standard	C	25.015 / 25.002	50	4	40	28	8	M10 x 1.5, 22 deep
04	Inch *	N	1.2500"/1.2495"	2.362"	-	2"	1.359"	1/4"	3/8" UNF x 0.86" deep
	Standard	C	30.015 / 30.002	60	4	50	33	8	M10 x 1.5, 22 deep
05	Inch *	N	1.3750"/1.3745"	2.756"	-	23/8"	1.507"	5/16"	3/8" UNF x 0.75" deep
	Standard	C	35.018 / 35.002	70	7	60	38	10	M12 x 1.75, 28 deep
06	Inch *	N	1.3750"/1.3745"	2.756"	-	23/8"	1.507"	5/16"	3/8" UNF x 0.75" deep
	Standard	C	35.018 / 35.002	70	7	60	38	10	M12 x 1.75, 28 deep
07	Inch *	N	1.6250"/1.6240"	3.150"	-	23/8"	1.784"	3/8"	5/8" UNF x 1.25" deep
	Standard	C	40.018 / 40.002	80	5	70	43	12	M16 x 2.0, 36 deep
08	Inch *	N	2.1250"/2.1240"	3.937"	-	23/4"	2.338"	1/2"	3/4" UNF x 1.50" deep
	Standard	C	50.018 / 50.002	100	10	80	53.5	14	M16 x 2.0, 36 deep
09	Inch *	N	2.3750" / 2.3740"	4.72"	-	311/16"	2.65"	0.625"	3/4" UNF 1.65" deep
	Standard	C	60.030 / 60.011	120	10	100	64	18	M20 x 2.5, 42 deep
10	Inch *	N	2.875" / 2.874"	5.51"	-	45/8"	3.20"	0.75"	3/4" UNF 1.65" deep
	Standard	C	70.030 / 70.011	140	15	110	74.5	20	M20 x 2.5, 42 deep
13	Inch *	N	3.625" / 3.624"	6.69"	-	515/16"	4.01"	0.875"	1" UNF 1.97" deep
	Standard	C	90.035 / 90.013	170	15	140	95	25	M24 x 3.0, 50 deep
14	Inch *	N	4.000" / 3.999"	8.27"	-	71/2"	4.44"	1.00"	1" UNF 1.97" deep
	Standard	C	100.035 / 100.013	210	15	180	106	28	M24 x 3.0, 50 deep

SERIES M

MOTOR ADAPTERS NEMA & IEC

DOUBLE REDUCTION UNITS

NEMA Flanges C Face - Column 12 Entry For Unit Types Column 10 Entries A, E and N Only

MOTOR FRAME FLANGE	UNIT SIZE, NUMBER OF REDUCTIONS, REVISION NUMBER																										
	RATIO COVERAGE		M0122	M0222	M0322	M0422	M0522	M0622	M0722	M0822	M0921	M1021	M1321	M1421													
	3.6 - 9.0	11. - 56.	3.6 - 14.	16. - 56.	3.6 - 14.	16. - 56.	3.6 - 11.	12. - 56.	3.6 - 11.	12. - 56.	5.0 - 12.	14. - 63.	3.6 - 9.0	11. - 56.	3.6 - 14.	16. - 56.	1.4 - 14.	16. - 71.	1.4 - 14.	16. - 71.	2.8 - 14.	16. - 45.	50. - 71.	2.8 - 14.	16. - 45.	50. - 71.	
56c	T	U	T	U	T	U	-	Q	-	Q	-	Q	-	Q	-	M	-	-	-	-	-	-	-	-	-	-	-
143/145TC	V	W	V	W	V	W	-	R	-	R	-	R	-	R	-	N	-	-	-	-	-	-	-	-	-	-	-
182/184TC	X	-	X	-	X	-	S	T	S	T	S	T	S	T	J	P	-	S	-	P	-	N	A	-	W	X	
213/215TC	-	-	-	-	-	-	U	-	U	-	U	-	U	V	K	Q	-	T	-	Q	-	P	B	-	N	A	
254/256TC	-	-	-	-	-	-	-	-	-	-	-	-	W	-	L	U	P	U	L	R	F	Q	C	E	P	B	
284/286TC	-	-	-	-	-	-	-	-	-	-	-	-	-	-	-	Q	V	M	S	G	R	D	F	Q	C	-	
324/326TC	-	-	-	-	-	-	-	-	-	-	-	-	-	-	-	R	W	N	T	H	S	E	G	R	D	-	
364/365TC	-	-	-	-	-	-	-	-	-	-	-	-	-	-	-	-	-	-	-	-	J	T	-	H	S	-	
404/405TC	-	-	-	-	-	-	-	-	-	-	-	-	-	-	-	-	-	-	-	-	K	U	-	J	T	-	

IEC Flanges B14 - Column 12 Entry For Unit Types Column 10 Entries G, H and M Only

MOTOR FRAME FLANGE	UNIT SIZE, NUMBER OF REDUCTIONS, REVISION NUMBER													
	RATIO COVERAGE		M0122	M0222	M0322	M0422	M0522	M0622	M0722					
	3.6 - 9.0	11. - 56.	3.6 - 14.	16. - 56.	3.6 - 14.	16. - 56.	3.6 - 11.	12. - 56.	3.6 - 11.	12. - 56.	5.0 - 12.	14. - 63.	3.6 - 9.0	11. - 56.
71	H	H	-	H	-	H	-	-	-	-	-	-	-	-
80	B	K	B	K	B	K	-	G	-	G	-	G	-	G
90	D	R	D	R	D	R	-	J	-	J	-	J	-	J
100	E	S	E	S	E	S	B	L	B	L	B	L	B	L
112	E	S	E	S	E	S	B	L	B	L	B	L	B	L
132	-	-	-	-	-	-	-	-	-	-	-	-	D	N

IEC Flanges B5 - Column 12 Entry For Unit Types Column 10 Entries G, H and M Only

MOTOR FRAME FLANGE	UNIT SIZE, NUMBER OF REDUCTIONS, REVISION NUMBER																										
	RATIO COVERAGE		M0122	M0222	M0322	M0422	M0522	M0622	M0722	M0822	M0921	M1021	M1321	M1421													
	3.6 - 9.0	11. - 56.	3.6 - 14.	16. - 56.	3.6 - 14.	16. - 56.	3.6 - 11.	12. - 56.	3.6 - 11.	12. - 56.	5.0 - 12.	14. - 63.	3.6 - 9.0	11. - 56.	3.6 - 14.	16. - 56.	1.4 - 14.	16. - 71.	1.4 - 14.	16. - 71.	2.8 - 14.	16. - 45.	50. - 71.	2.8 - 14.	16. - 45.	50. - 71.	
63	F	F	-	F	-	F	-	V	-	V	-	V	-	-	-	-	-	-	-	-	-	-	-	-	-	-	-
71	G	G	-	G	-	G	-	D	-	D	-	D	-	-	-	-	-	-	-	-	-	-	-	-	-	-	-
80	A	J	A	J	A	J	W	F	W	F	W	F	-	F	-	D	-	E	-	-	-	-	-	-	-	-	-
90	C	Q	C	Q	C	Q	Y	H	Y	H	Y	H	-	H	-	E	-	F	-	-	-	-	-	-	-	-	-
100	-	-	-	-	-	-	A	K	A	K	A	K	A	K	A	F	-	G	-	E	-	G	N	-	S	W	
112	-	-	-	-	-	-	A	K	A	K	A	K	A	K	A	F	-	G	-	E	-	G	N	-	S	W	
132	-	-	-	-	-	-	N	P	N	P	N	P	C	M	B	G	-	H	-	F	-	H	P	-	T	X	
160	-	-	-	-	-	-	-	-	-	-	-	-	E	-	C	H	A	J	A	G	A	J	Q	A	G	N	
180	-	-	-	-	-	-	-	-	-	-	-	-	-	-	-	-	B	K	B	H	B	K	R	B	H	P	
200	-	-	-	-	-	-	-	-	-	-	-	-	-	-	-	-	C	-	C	-	C	L	S	C	J	Q	
225	-	-	-	-	-	-	-	-	-	-	-	-	-	-	-	-	D	-	D	-	E	M	T	D	K	R	
250	-	-	-	-	-	-	-	-	-	-	-	-	-	-	-	-	-	-	-	-	D	U	-	E	L	-	
280	-	-	-	-	-	-	-	-	-	-	-	-	-	-	-	-	-	-	-	-	F	W	-	F	M	-	

■ Limited Availability / Non Preferred

SERIES M

MOTOR ADAPTERS NEMA & IEC

TRIPLE REDUCTION UNITS

NEMA Flanges C Face - Column 12 Entry For Unit Types Column 10 Entries A, E and N Only

MOTOR FRAME FLANGE	UNIT SIZE, NUMBER OF REDUCTIONS, REVISION NUMBER																	
	RATIO COVERAGE	M0132	M0232	M0332	M0432	M0532	M0632	M0732	M0832	M0931	M1031	M1331		M1431				
		56. - 200	56. - 200	56. - 200	56. - 200	56. - 200	63. - 25	56. - 200	56. - 200	56. - 200	56. - 250	56. - 250	40. - 50.	56. - 160	180 - 250	40. - 50.	56. - 160	180 - 250
56c	COLUMN 12 ENTRY	U	U	U	U	U	U	Q	Q	X	-	-	-	-	-	-	-	
143/145TC		W	W	W	W	W	W	R	R	Y	-	-	-	-	-	-	-	
182/184TC		-	-	-	-	-	-	-	T	T	Z	S	-	N	A	-	N	A
213/215TC		-	-	-	-	-	-	-	-	V	-	T	-	P	B	-	P	B
254/256TC		-	-	-	-	-	-	-	-	-	-	U	F	Q	C	F	Q	C
284/286TC		-	-	-	-	-	-	-	-	-	-	V	G	R	D	G	R	D
324/326TC		-	-	-	-	-	-	-	-	-	-	W	H	S	E	H	S	E
364/365TC		-	-	-	-	-	-	-	-	-	-	-	J	T	-	J	T	-
404/405TC		-	-	-	-	-	-	-	-	-	-	-	K	U	-	K	U	-

IEC Flanges B14 - Column 12 Entry For Unit Types Column 10 Entries G, H and M Only

MOTOR FRAME FLANGE	UNIT SIZE, NUMBER OF REDUCTIONS, REVISION NUMBER								
	RATIO COVERAGE	M0132	M0232	M0332	M0432	M0532	M0632	M0732	M0832
		56. - 200	56. - 200	56. - 200	56. - 200	56. - 200	63. - 25	56. - 200	56. - 200
71	COLUMN 12 ENTRY	H	H	H	H	H	-	-	-
80		K	K	K	K	K	K	G	G
90		R	R	R	R	R	R	J	J
100		S	S	S	S	S	S	L	L
112		S	S	S	S	S	S	L	L
132		-	-	-	-	-	-	-	N

IEC Flanges B5 - Column 12 Entry For Unit Types Column 10 Entries G, H and M Only

MOTOR FRAME FLANGE	UNIT SIZE, NUMBER OF REDUCTIONS, REVISION NUMBER																	
	RATIO COVERAGE	M0132	M0232	M0332	M0432	M0532	M0632	M0732	M0832	M0931	M1031	M1331		M1431				
		56. - 200	56. - 200	56. - 200	56. - 200	56. - 200	63. - 25	56. - 200	56. - 200	56. - 250	56. - 250	40. - 50.	56. - 160	180 - 250	40. - 50.	56. - 160	180 - 250	
63	COLUMN 12 ENTRY	F	F	F	F	F	F	V	-	-	-	-	-	-	-	-		
71		G	G	G	G	G	G	D	-	-	-	-	-	-	-	-		
80		J	J	J	J	J	J	F	F	L	F	-	-	-	-	-		
90		Q	Q	Q	Q	Q	Q	H	H	M	F	-	-	-	-	-		
100		-	-	-	-	-	-	-	K	K	N	G	-	G	N	-	G	N
112		-	-	-	-	-	-	-	K	K	N	G	-	G	N	-	G	N
132		-	-	-	-	-	-	-	P	M	-	H	-	H	P	-	H	P
160		-	-	-	-	-	-	-	-	-	-	-	A	J	Q	A	J	Q
180		-	-	-	-	-	-	-	-	-	-	-	B	K	R	B	K	R
200		-	-	-	-	-	-	-	-	-	-	-	C	L	S	C	L	S
225		-	-	-	-	-	-	-	-	-	-	-	D	M	T	D	M	T
250		-	-	-	-	-	-	-	-	-	-	-	E	U	-	E	U	-
280		-	-	-	-	-	-	-	-	-	-	-	F	W	-	F	X	-

■ Limited Availability / Non Preferred

SERIES M

MOTOR ADAPTERS NEMA & IEC

QUADRUPLE REDUCTION UNITS

NEMA Flanges C Face - Column 12 Entry For Unit Types Column 10 Entries A, E and N Only

MOTOR FRAME FLANGE	UNIT SIZE, NUMBER OF REDUCTIONS, REVISION NUMBER										
	RATIO COVERAGE	M0342	M0442	M0542	M0642	M0742	M0842	M0941	M1041	M1341	M1441
56c	COLUMN 12 ENTRY	U	U	U	U	U	Q	Q	Q	Q	Q
143/145TC		W	W	W	W	W	R	R	R	R	R
182/184TC		-	-	-	-	-	T	T	T	T	T
213/215TC		-	-	-	-	-	-	-	V	V	V

IEC Flanges B14 - Column 12 Entry For Unit Types Column 10 Entries G, H and M Only

MOTOR FRAME FLANGE	UNIT SIZE, NUMBER OF REDUCTIONS, REVISION NUMBER										
	RATIO COVERAGE	M0342	M0442	M0542	M0642	M0742	M0842	M0941	M1041	M1341	M1441
71	COLUMN 12 ENTRY	H	H	H	H	H	-	-	-	-	-
80		K	K	K	K	K	G	G	G	G	G
90		R	R	R	R	R	J	J	J	J	J
100		-	-	-	-	-	L	L	L	L	L
112		-	-	-	-	-	L	L	L	L	L
132		-	-	-	-	-	-	-	N	N	N

IEC Flanges B5 - Column 12 Entry For Unit Types Column 10 Entries G, H and M Only

MOTOR FRAME FLANGE	UNIT SIZE, NUMBER OF REDUCTIONS, REVISION NUMBER										
	RATIO COVERAGE	M0342	M0442	M0542	M0642	M0742	M0842	M0941	M1041	M1341	M1441
63	COLUMN 12 ENTRY	F	F	F	F	F	V	V	-	-	-
71		G	G	G	G	G	D	D	-	-	-
80		J	J	J	J	J	F	F	F	F	F
90		Q	Q	Q	Q	Q	H	H	H	H	H
100		-	-	-	-	-	K	K	K	K	K
112		-	-	-	-	-	K	K	K	K	K
132		-	-	-	-	-	P	P	M	M	M

 Limited Availability / Non Preferred

SERIES M

MOTOR ADAPTERS NEMA & IEC

QUINTUPLE REDUCTION UNITS

NEMA Flanges C Face - Column 12 Entry For Unit Types Column 10 Entries A, E and N Only

MOTOR FRAME FLANGE	UNIT SIZE, NUMBER OF REDUCTIONS, REVISION NUMBER										
	RATIO COVERAGE	M0352	M0452	M0552	M0652	M0752	M0852	M0951	M1051	M1351	M1451
56c	COLUMN 12 ENTRY	U	U	U	U	U	U	U	Q	Q	Q
143/145TC		W	W	W	W	W	W	W	R	R	R
182/184TC		-	-	-	-	-	-	-	T	T	T

IEC Flanges B14 - Column 12 Entry For Unit Types Column 10 Entries G, H and M Only

MOTOR FRAME FLANGE	UNIT SIZE, NUMBER OF REDUCTIONS, REVISION NUMBER										
	RATIO COVERAGE	M0352	M0452	M0552	M0652	M0752	M0852	M0951	M1051	M1351	M1451
71	COLUMN 12 ENTRY	H	H	H	H	H	H	H	-	-	-
80		K	K	K	K	K	K	K	G	G	G
90		R	R	R	R	R	R	R	J	J	J

IEC Flanges B5 - Column 12 Entry For Unit Types Column 10 Entries G, H and M Only

MOTOR FRAME FLANGE	UNIT SIZE, NUMBER OF REDUCTIONS, REVISION NUMBER										
	RATIO COVERAGE	M0352	M0452	M0552	M0652	M0752	M0852	M0951	M1051	M1351	M1451
63	COLUMN 12 ENTRY	F	F	F	F	F	F	F	-	-	-
71		G	G	G	G	G	G	G	-	-	-
80		J	J	J	J	J	J	J	F	F	F
90		Q	Q	Q	Q	Q	Q	Q	H	H	H
100		-	-	-	-	-	-	-	K	K	K
112		-	-	-	-	-	-	-	K	K	K

Limited Availability / Non Preferred

SERIES M

LUBRICATION

M01,M02,M03,M04,M05,M06,& M07 Units, are supplied factory filled with EP mineral oil (Grade 6E) appropriate to the intended mounting position. If the unit is supplied without lubricant the unit must be filled with the correct lubricant and quantity as listed below.

M08,M09,M10,M13,& M14 Units, require filling with EP mineral oil (Grade 6E)
Lubricant quantities are approximate fill until oil escapes from the level plug hole, fit ventilator plug (when supplied) in the appropriate position for the required mounting position. If the unit is supplied without lubricant the unit must be filled with the correct lubricant and quantity.

TEMPERATURE LIMITATIONS

The standard lubricant is suitable for operation in ambient temperatures of 32°F to 122°F, outside of this consult Table 1 or Application Engineers.

TABLE 1 OIL GRADES

LUBRICANT	AMBIENT TEMPERATURE RANGE		
	40°F to 68°F (type E) -22°F to 68°F (type H)	32°F to 95°F	68°F to 122°F
EP Mineral Oil (type E)	5E (VG 220)	6E (VG 320)	7E (VG 460)
Polyalphaolefin based Synthetic (type H)	5H (VG 220)	5H (VG 220)	6H (VG 320)

TABLE 2 Lubrication Quantity Gallons (US)

Oil quantities are approximate, fill gearbox until oil escapes from level plug hole
Do not overfill as excess lubricant may cause overheating and leakage

1 gallon (US) = 3.79 liter

DOUBLE REDUCTION & FINAL STAGE QUADRUPLE OR QUINTUPLE REDUCTION													
Unit Size	M0122	M0222	M0322	M0422	M0522	M0622	M0722	M0822	M0921	M1021	M1321	M1421	
MOUNTING POSITION	1	0.13	0.21	0.21	0.39	0.39	0.52	0.68	1.1	2.7	2.9	4.4	6.2
	2	0.21	0.31	0.31	0.47	0.47	0.52	0.75	1.6	3.1	5.7	8.1	12.7
	3	0.16	0.18	0.18	0.42	0.42	0.49	0.70	1.4	3.1	5.7	8.1	12.7
	4	0.21	0.31	0.31	0.47	0.47	0.44	0.78	1.9	3.1	4.9	7.3	10.7
	5	0.18	0.29	0.29	0.52	0.52	0.57	0.83	1.8	4.4	8.3	12.2	18.7
	6	0.26	0.36	0.36	0.68	0.68	0.73	1.2	2.4	4.3	6.8	9.9	16.9

Unit Size	M0132	M0232	M0332	M0432	M0532	M0632	M0732	M0832	M0931	M1031	M1331	M1431	
MOUNTING POSITION	1	0.16	0.21	0.21	0.42	0.42	0.55	0.70	1.1	3.0	2.9	4.7	6.4
	2	0.23	0.34	0.34	0.49	0.49	0.55	0.78	1.7	3.1	6.2	8.6	13.0
	3	0.18	0.18	0.18	0.44	0.44	0.52	0.73	1.5	3.1	6.2	8.6	13.0
	4	0.23	0.31	0.31	0.49	0.49	0.47	0.81	2.0	3.1	5.5	7.8	11.2
	5	0.18	0.29	0.29	0.55	0.55	0.60	0.86	1.8	4.4	8.3	12.2	18.7
	6	0.29	0.42	0.42	0.70	0.70	0.75	1.2	2.5	4.3	7.3	10.4	17.4

PRIMARY STAGE QUADRUPLE REDUCTION (Quantities obtained from above double and triple sizes indicated)										
Unit Size	M0342	M0442	M0542	M0642	M0742	M0842	M0941	M1041	M1341	M1441
PRIMARY UNIT	M0122	M0322	M0322	M0322	M0322	M0522	M0522	M0722	M0722	M0722
SECONDARY UNIT	M0322	M0422	M0522	M0622	M0722	M0822	M0921	M1021	M1321	M1421

PRIMARY STAGE QUINTUPLE REDUCTION (Quantities obtained from above double and triple sizes indicated)										
Unit Size	M0352	M0452	M0552	M0652	M0752	M0852	M0951	M1051	M1351	M1451
PRIMARY UNIT	M0132	M0332	M0332	M0332	M0332	M0532	M0532	M0732	M0732	M0732
SECONDARY UNIT	M0322	M0422	M0522	M0622	M0722	M0822	M0921	M1021	M1321	M1421

SERIES M

MOUNTING POSITIONS

COLUMN 13 ENTRY

Enter for units with no oil fill

Base Mounted Units

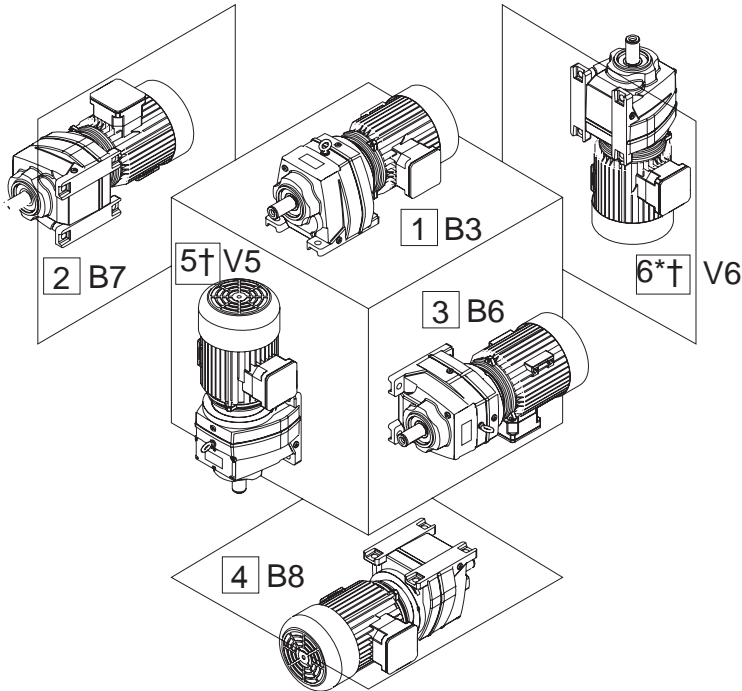

Flange Mounted Units

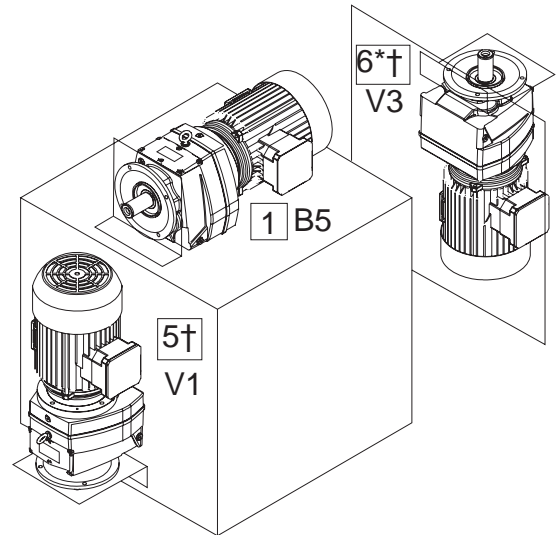

* Mounting Position 6 is not recommended for Geared Motors - Consult Application Engineering
 † Gear Units selected for use in mounting positions 5 and 6 should only be used with overall ratios greater or equal to those shown in the table below

Unit Size	Input Speed (rpm)			
	< 1000	< 1500	< 1800	> 1800
M01 - M08	3.6	3.6	3.6	Consult Application Engineering
M09	2.0	4.0	4.5	
M10	4.0	8.0	9.0	
M13	6.3	11.0	14.0	
M14	12.0	18.0	22.0	

MOUNTING POSITIONS - SHOWN AS MOTORIZED - APPLIES ALSO FOR REDUCERS

COLUMN 14 ENTRY

ALL MOTORS

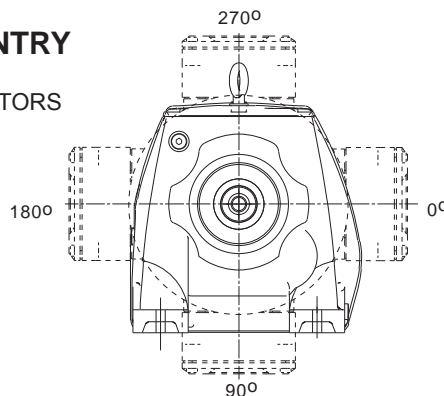

Column 14 Entry	Terminal Box Position
A	0°
B	90°
C	180°
D	270°
-	Reducer or no motor fitted

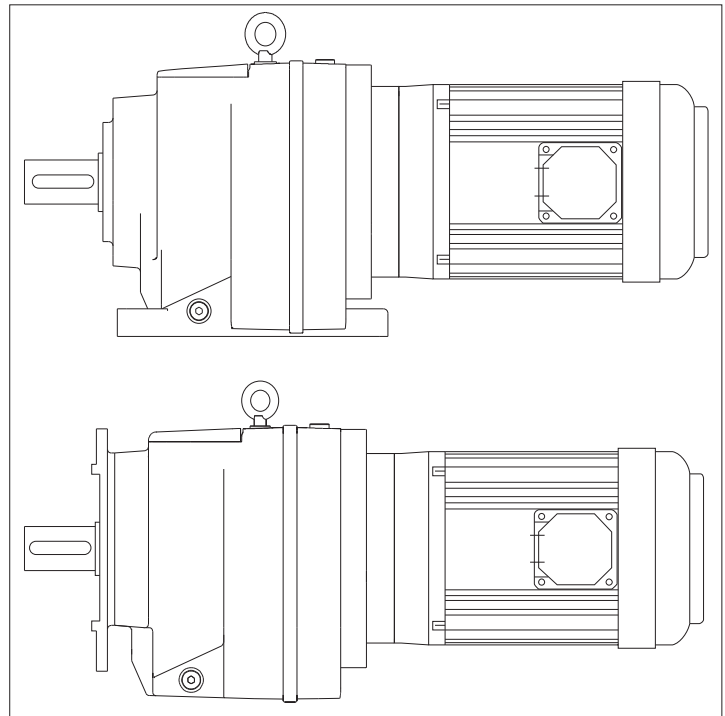

**MOTORIZED
SERIES M**

SERIES M

MOTOR DETAILS

NEMA Standard Motors

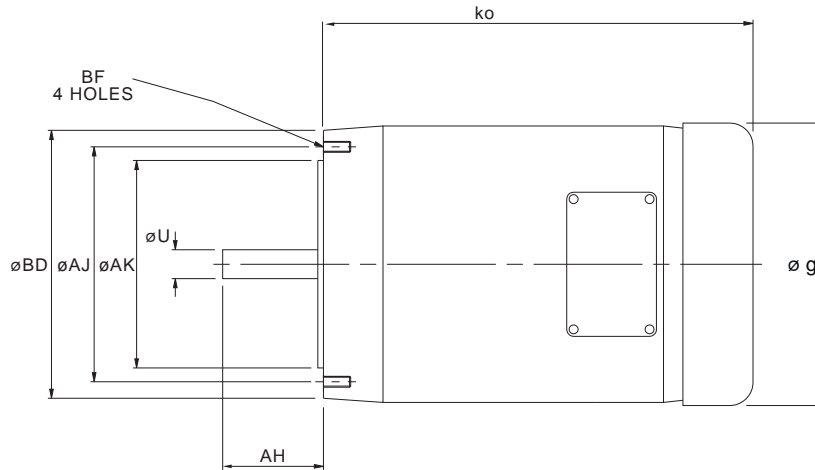

MOTOR FRAME SIZE	$\varnothing BD$	$\varnothing AJ$	$\varnothing AK$	$\varnothing U$	AH	ko_{max}	$\varnothing g$	BF TAP UNC
56C	6.50	5.875	4.5	0.625	2.062	12.00	6.13	3/8 - 16
143TC/145TC	6.50	5.875	4.5	0.875	2.125	12.00	7.19	3/8 - 16

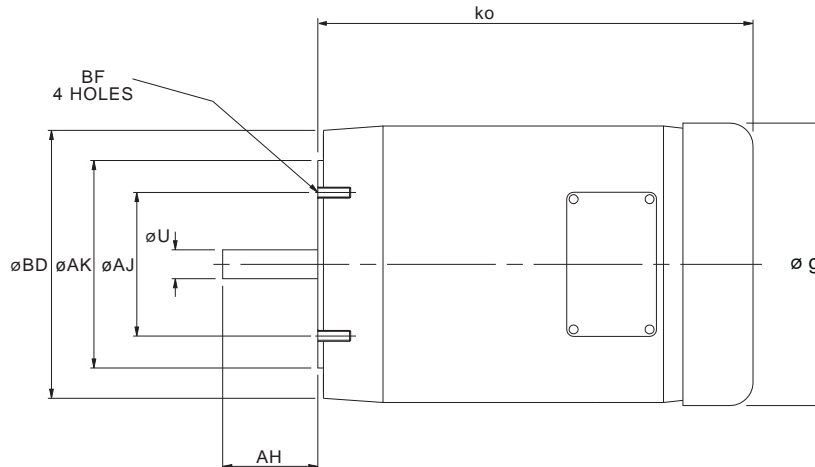

MOTOR FRAME SIZE	$\varnothing BD$	$\varnothing AJ$	$\varnothing AK$	$\varnothing U$	AH	ko_{max}	$\varnothing FP$	BF TAP UNC
182TC/184TC	9.00	7.25	8.5	1.125	2.625	15.50	8.50	1/2 - 13
213TC/215TC	9.00	7.25	8.5	1.375	3.125	16.50	10.19	1/2 - 13
254TC/256TC	10.00	7.25	8.5	1.625	3.75	20.00	12.50	1/2 - 13
284TC/286TC	11.25	9.00	10.5	1.875	4.375	23.25	15.56	1/2 - 13
324TC/326TC	13.875	11.00	12.5	2.125	5.00	25.25	16.94	5/8 - 11
364TC/365TC	13.875	11.00	12.5	2.375	5.625	27.00	19.00	5/8 - 11
404TC/405TC	13.875	11.00	12.5	2.875	7.00	30.00	20.63	5/8 - 11

* Motor lengths for our standard motors.
These lengths may vary if alternative motor is fitted.

SERIES M

ADDITIONAL MOTOR FEATURES

ADDITIONAL MOTOR FEATURES - COLUMN 19 ENTRY

Column 19 Entry	Brake Motor	Hand Release on Brake	Forced Ventilation/ Constant Blower (TECB)	Thermistors	Special
-					
A	•				
B	•	•			
C			•		
D	•		•		
E	•	•	•		
F				•	
G	•			•	
H	•	•		•	
K			•	•	
L	•		•	•	
M	•	•	•	•	
S					•

Please refer to our Application Engineers for details of the following additional motor features:

- Wash down
- Customized brake torque
- Seperate brake supply
- Anti Condensation heater
- Bi-metal temperature detectors, Thermostat
- Metal fan cover
- Rain cowl
- Seperate terminal box

SERIES M

ADDITIONAL GEARBOX FEATURES

ADDITIONAL GEARBOX FEATURES - COLUMN 20 ENTRY

Column 20 Entry	Double Outputshaft Oil* Seals	Oil Level** Glass	Motorized Backstop***		Special****
			CW Rotation	CCW Rotation	
-					
A	•				
B		•			
C	•	•			
D			•		
E	•		•		
F		•	•		
G	•	•	•		
H				•	
I	•			•	
J		•		•	
K	•	•		•	
L					•

*Double oil seals are for output shafts, sizes M08 to M14 only

**Oil level glass is NOT AVAILABLE on M01 - M06 units.

***Limited frame size availability see page 60.

****Please refer to our Application Engineers for details regarding special gearbox features.

SERIES M

SELECTION TABLES

GEARED MOTORS

0.25 HP

4 POLE
1750 rpm
nominal
input speed

N2 R/MIN	i	M2 lb.in	Fm	lb	Unit Designation	lb	Motor Size
Output Speed	Ratio	Output Torque	Service Factor	Overhung Load	Column Entry 1 Through 20 Spaces to be filled when entering order	Weight of base mount unit	
460	3.75	33	14.91	364	M 0 1 2 2 3 . 6 _ N _ _ _ _ . 2 5 B - -	40	56C
341	5.07	44	12.58	384	5 . 0		
299	5.76	50	11.69	393	5 . 6		
264	6.53	57	10.79	404	6 . 3		
207	8.35	73	9.25	422	8 . 0		
192	9	79	8.72	427	9 . 0		
152	11.36	99	7.24	427	1 1 ,		
134	12.88	114	6.5	427	1 2 ,		
117	14.71	130	5.87	427	1 4 ,		
105	16.37	143	5.45	427	1 6 ,		
96	18.05	159	4.99	427	1 8 ,		
87	19.86	175	4.54	427	2 0 ,		
74	23.27	204	3.88	427	2 2 ,		
62	27.92	245	3.24	426	2 8 ,		
53	32.54	285	2.78	427	3 2 ,		
48	36.16	316	2.51	426	3 6 ,		
40	43.54	381	1.94	427	4 5 ,		
35	49.91	437	1.45	427	5 0 ,		
30	56.72	496	1.26	427	5 6 ,		
30	58.46	502	1.58	427	M 0 1 3 2 5 6 . _ N _ _ _ _ . 2 5 B - -	42.3	56C
27	64.45	556	1.43	426	6 3 ,		
24	70.93	611	1.3	424	7 1 ,		
21	83.1	715	1.11	399	8 0 ,		
17	99.7	858	0.93	310	1 0 0		
42	41.49	364	3.88	899	M 0 2 2 2 4 5 . _ N _ _ _ _ . 2 5 B - -	46.7	56C
37	47.09	413	3.42	899	5 0 ,		
32	53.54	469	3.01	899	5 6 ,		
30	57.03	495	2.86	899	M 0 2 3 2 5 6 . _ N _ _ _ _ . 2 5 B - -	48.9	56C
27	62.87	546	2.59	899	6 3 ,		
25	69.19	600	2.36	899	7 1 ,		
21	81.07	702	2.01	899	8 0 ,		
18	97.26	842	1.68	899	1 0 0		
15	113.37	981	1.44	899	1 1 2		
14	125.97	1088	1.3	899	1 2 5		
11	151.69	1312	1.08	898	1 6 0		
10	173.87	1504	0.94	899	1 8 0		
8.7	197.6	1705	0.83	804	2 0 0		
32	53.54	470	3.88	899	M 0 3 2 2 5 6 . _ N _ _ _ _ . 2 5 B - -	46.7	56C
30	57.03	494	3.74	899	M 0 3 3 2 5 6 . _ N _ _ _ _ . 2 5 B - -	48.9	56C
27	62.87	546	3.38	898	6 3 ,		
25	69.19	601	3.08	899	7 1 ,		
21	81.07	703	2.63	898	8 0 ,		
18	97.26	843	2.19	899	1 0 0		
15	113.37	982	1.88	898	1 1 2		
14	125.97	1089	1.7	898	1 2 5		
11	151.69	1315	1.41	898	1 6 0		
10	173.87	1507	1.23	897	1 8 0		
8.7	197.6	1706	1.08	801	2 0 0		
7.3	234.96	1970	0.94	680	M 0 3 4 2 2 2 5 _ N _ _ _ _ . 2 5 B - -	68.7	56C
6.6	261.37	2187	0.85	680	2 5 0		
18	96.52	839	3.56	1618	M 0 4 3 2 1 0 0 _ N _ _ _ _ . 2 5 B - -	68.7	56C
15	115.82	1004	2.98	1618	1 1 2		
13	130.5	1131	2.64	1618	1 2 5		
11	151.71	1318	2.27	1618	1 6 0		
10	172.19	1492	2	1618	1 8 0		
8.8	195.75	1693	1.77	1618	2 0 0		
7.4	232.81	1959	1.53	1601	M 0 4 4 2 2 2 5 _ N _ _ _ _ . 2 5 B - -	95.2	56C
6.6	260.47	2183	1.37	1601	2 5 0		
6.2	277.62	2325	1.29	1601	2 8 0		
5.6	305.72	2565	1.17	1601	3 0 0		
4.8	362.32	3024	0.99	1601	3 6 0		
4.1	416.75	3480	0.86	1601	4 0 0		
3.9	444.96	3707	0.81	1601	4 5 0		
15	115.82	1007	3.96	1618	M 0 5 3 2 1 1 2 _ N _ _ _ _ . 2 5 B - -	70.9	56C
13	130.5	1134	3.51	1618	1 2 5		
11	151.71	1319	3.02	1618	1 6 0		
10	172.19	1497	2.66	1617	1 8 0		
8.8	195.75	1696	2.35	1618	2 0 0		

NOTE

Other output speeds are available using 2 and 6 pole motors - Consult Application Engineering

SERIES M

SELECTION TABLES

GEARED MOTORS

0.25 HP

4 POLE
1750 rpm
nominal
input speed

N2 R/MIN	i	M2 lb.in	Fm	lb	Unit Designation	lb	Motor Size
Output Speed	Ratio	Output Torque	Service Factor	Overhung Load	Column Entry 1 Through 20 Spaces to be filled when entering order	Weight of base mount unit	
7.4	232.81	1970	2.02	1081	M 0 5 4 2 2 2 5 _ N _ _ _ . 2 5 B - -	99.6	56C
6.6	260.47	2197	1.81	1081	2 5 0		
6.2	277.62	2341	1.7	1081	2 8 0		
5.6	305.72	2581	1.54	1081	3 0 0		
4.8	362.32	3046	1.31	1081	3 6 0		
4.1	416.75	3504	1.14	1081	4 0 0		
3.9	444.96	3735	1.07	1081	4 5 0		
3.6	483.76	4061	0.98	1081	5 0 0		
11	161.57	1404	3.94	1618	M 0 6 3 2 1 6 0 _ N _ _ _ . 2 5 B - -	81.9	56C
9.2	187.83	1634	3.39	1618	1 8 0		
8.1	213.18	1851	2.99	1618	2 0 0		
8	215.23	1833	3.02	1618	M 0 6 4 2 2 2 5 _ N _ _ _ . 2 5 B - -	110.6	56C
7.3	237.02	2021	2.74	1618	2 5 0		
6.3	272.91	2317	2.02	1618	2 8 0		
5.5	313.91	2665	1.76	1618	3 0 0		
4.7	365.1	3097	1.71	1618	3 6 0		
4.3	396.93	3366	1.57	1618	4 0 0		
3.9	444.1	3758	1.47	1618	4 5 0		
3.2	533.13	4508	1.23	1618	5 0 0		
3	568.23	4805	1.15	1618	6 5 0		
2.5	681.88	5759	0.96	1618	7 3 0		
2.1	808.12	6805	0.81	1618	8 6 0		
7.5	229	1950	3.94	1051	M 0 7 4 2 2 2 5 _ N _ _ _ . 2 5 B - -	126	56C
6.6	259.68	2206	3.48	1051	2 5 0		
6	286.42	2432	3.16	1051	2 8 0		
5.5	315.41	2681	2.86	1051	3 0 0		
4.8	361.21	3065	2.51	1051	3 6 0		
4.2	415.49	3523	2.18	1051	4 0 0		
3.7	469.77	3975	1.93	1051	4 5 0		
3.4	510.72	4321	1.78	1051	5 0 0		
2.9	592.12	4995	1.54	1051	6 5 0		
2.4	710.84	5993	1.28	1051	7 3 0		
2	847.84	7123	1.08	1050	8 6 0		
1.7	1017.41	8538	0.9	1050	1 0 C		
1.5	1114.17	9331	0.82	1050	1 1 C		
4.1	425.69	3610	3.59	4017	M 0 8 4 2 4 0 0 _ N _ _ _ . 2 5 B - -	229.6	56C
3.6	480.51	4068	3.35	3775	4 5 0		
3.4	513.04	4343	3.13	3775	5 0 0		
2.8	621.92	5249	2.78	3407	6 5 0		
2.2	771.75	6513	2.24	3407	7 3 0		
1.9	900	7568	1.93	3407	8 6 0		
1.6	1061.28	8922	1.64	3407	1 0 C		
1.5	1165.78	9779	1.49	3407	1 1 C		
1.4	1276.51	10706	1.36	3407	1 3 C		
1.1	1564.35	13072	1.12	3407	1 5 C		
0.9	1917.16	16014	0.91	3407	1 8 C		
0.82	2093.54	17444	0.84	3407	2 0 C		
2	882.06	7502	3.37	5609	M 0 9 4 1 8 6 0 _ N _ _ _ . 2 5 B - -	324.4	56C
1.7	1040.13	8839	2.86	5609	1 0 C		
1.5	1148.27	9755	2.59	5609	1 1 C		
1.3	1339.57	11310	2.24	5609	1 3 C		
1.1	1579.63	13332	1.9	5609	1 5 C		
1.0	1729.67	14593	1.73	5609	1 8 C		
0.81	2119.76	17864	1.42	5609	2 0 C		
0.73	2362.65	19902	1.27	5609	2 4 C		
0.65	2649.71	22296	1.13	5609	2 7 C		
0.66	2597.62	21565	1.17	5609	M 0 9 5 1 2 7 C _ N _ _ _ . 2 5 B - -	328.8	56C
0.55	3118.4	25868	0.98	5609	3 2 C		
0.46	3742.08	30991	0.82	5609	3 6 C		
0.71	2445.35	20154	1.94	9347	M 1 0 5 1 2 7 C _ N _ _ _ . 2 5 B - -	469.9	56C
0.57	3034.45	25014	1.56	9347	3 2 C		
0.48	3578.24	29487	1.32	9347	3 6 C		
0.44	3918.11	32276	1.21	9347	4 0 C		
0.38	4514.53	37052	1.05	9347	4 6 C		
0.31	5532.7	45363	0.86	9347	5 5 C		

NOTE

Other output speeds are available using 2 and 6 pole motors - Consult Application Engineering

SERIES M

SELECTION TABLES

GEARED MOTORS

0.25 HP	N2 R/MIN	i	M2 lb.in	Fm	lb	Unit Designation	lb	Motor Size
	Output Speed	Ratio	Output Torque	Service Factor	Overhung Load	Column Entry 1 Through 20 Spaces to be filled when entering order	Weight of base mount unit	
4 POLE 1750 rpm nominal input speed	0.68	2535.33	20904	2.69	14529	M 1 3 5 1 2 7 C _ N _ _ _ . 2 5 B - -	635.3	56C
	0.55	3146.12	25929	2.17	14529	3 2 C		
	0.46	3709.92	30554	1.84	14529	3 6 C		
	0.42	4062.29	33437	1.68	14529	4 0 C		
	0.38	4524.38	37141	1.51	14529	4 6 C		
	0.31	5544.77	45446	1.24	14529	5 5 C		
	0.25	6782.84	55279	1.04	14543	6 5 C		
	0.23	7560.04	61573	0.93	14543	7 4 C		
	0.2	8478.55	68953	0.83	14543	8 4 C		
	0.51	3404.7	28222	3.34	18122	M 1 4 5 1 3 2 C _ N _ _ _ . 2 5 B - -		
	0.43	4014.85	33240	2.84	18122	3 6 C		
	0.39	4396.19	36368	2.59	18122	4 0 C		
	0.35	4968.85	40941	2.19	18144	4 6 C		
	0.32	5440.8	44797	2	18144	5 5 C		
	0.26	6667.87	54781	1.63	18144	6 5 C		
	0.23	7431.9	60997	1.47	18144	7 4 C		
	0.21	8334.84	68282	1.31	18144	8 4 C		
	0.17	10191.76	83272	0.99	18144	9 5 C		
	0.15	11430.01	93259	0.88	18144	1 0 K		
	0.33 HP	460	3.75	43	11.3	361	M 0 1 2 2 3 . 6 _ N _ _ _ . 3 3 B - -	42
341		5.07	58	9.53	381	5 . 0		
299		5.76	67	8.85	389	5 . 6		
264		6.53	76	8.17	400	6 . 3		
207		8.35	97	7.01	417	8 . 0		
192		9	104	6.61	421	9 . 0		
152		11.36	131	5.49	420	1 1 ,		
134		12.88	150	4.93	419	1 2 ,		
117		14.71	171	4.45	421	1 4 ,		
105		16.37	189	4.13	419	1 6 ,		
96		18.05	210	3.78	414	1 8 ,		
87		19.86	231	3.44	424	2 0 ,		
74		23.27	270	2.94	417	2 2 ,		
62		27.92	323	2.45	404	2 8 ,		
53		32.54	376	2.11	408	3 2 ,		
48		36.16	418	1.9	396	3 6 ,		
40		43.54	503	1.47	411	4 5 ,		
35		49.91	576	1.1	427	5 0 ,		
30		56.72	655	0.95	413	5 6 ,		
30		58.46	663	1.2	413	M 0 1 3 2 5 6 . _ N _ _ _ . 3 3 B - -	44.3	
27		64.45	734	1.08	395	6 3 ,		
24		70.93	806	0.99	348	7 1 ,		
21		83.1	944	0.84	242	8 0 ,		
54		31.68	367	3.85	894	M 0 2 2 2 3 2 . _ N _ _ _ . 3 3 B - -	48.7	56C
48		35.69	413	3.42	899	3 6 ,		
42		41.49	481	2.94	899	4 5 ,		
37		47.09	546	2.59	892	5 0 ,		
32		53.54	620	2.28	875	5 6 ,		
30		57.03	653	2.17	899	M 0 2 3 2 5 6 . _ N _ _ _ . 3 3 B - -	50.9	56C
27		62.87	721	1.96	891	6 3 ,		
25		69.19	792	1.79	899	7 1 ,		
21		81.07	927	1.53	899	8 0 ,		
18		97.26	1111	1.27	873	1 0 0		
15		113.37	1294	1.09	899	1 1 2		
14		125.97	1437	0.99	899	1 2 5		
11		151.69	1732	0.82	782	1 6 0		
42		41.49	480	3.59	870	M 0 3 2 2 4 5 . _ N _ _ _ . 3 3 B - -	48.7	56C
37		47.09	546	3.24	892	5 0 ,		
32		53.54	620	2.94	875	5 6 ,		
30		57.03	653	2.83	867	M 0 3 3 2 5 6 . _ N _ _ _ . 3 3 B - -	50.9	56C
27	62.87	721	2.56	851	6 3 ,			
25	69.19	793	2.33	872	7 1 ,			
21	81.07	929	1.99	836	8 0 ,			
18	97.26	1112	1.66	873	1 0 0			
15	113.37	1297	1.43	808	1 1 2			
14	125.97	1438	1.29	757	1 2 5			
11	151.69	1736	1.07	782	1 6 0			
10	173.87	1990	0.93	599	1 8 0			
8.7	197.6	2252	0.82	406	2 0 0			
32	54	626	3.82	1618	M 0 4 2 2 5 6 . _ N _ _ _ . 3 3 B - -	66.3	56C	

NOTE
Other output speeds are available using 2 and 6 pole motors - Consult Application Engineering

SERIES M

SELECTION TABLES

GEARED MOTORS

0.33 HP

4 POLE
1750 rpm
nominal
input speed

N2 R/MIN	i	M2 lb.in	Fm	lb	Unit Designation	lb	Motor Size
Output Speed	Ratio	Output Torque	Service Factor	Overhung Load	Column Entry 1 Through 20 Spaces to be filled when entering order	Weight of base mount unit	
23	73.95	850	3.52	1618	M 0 4 3 2 7 1 . . . N _ _ _ . . . 3 3 B _ _	70.7	56C
21	80.4	924	3.24	1618	8 0 .		
18	96.52	1108	2.7	1613	1 0 0		
15	115.82	1326	2.26	1618	1 1 2		
13	130.5	1493	2	1610	1 2 5		
11	151.71	1740	1.72	1618	1 6 0		
10	172.19	1970	1.52	1618	1 8 0		
8.8	195.75	2236	1.34	1602	2 0 0		
7.4	232.81	2586	1.16	1601	M 0 4 4 2 2 2 5 _ N _ _ _ . . . 3 3 B _ _	97.2	56C
6.6	260.47	2882	1.04	1601	2 5 0		
6.2	277.62	3069	0.97	1601	2 8 0		
5.6	305.72	3386	0.88	1601	3 0 0		
32	54	626	3.82	1615	M 0 5 2 2 5 6 . . . N _ _ _ . . . 3 3 B _ _	68.5	56C
18	96.52	1109	3.59	1598	M 0 5 3 2 1 0 0 _ N _ _ _ . . . 3 3 B _ _	72.9	56C
15	115.82	1329	3	1561	1 1 2		
13	130.5	1497	2.66	1533	1 2 5		
11	151.71	1741	2.29	1538	1 6 0		
10	172.19	1976	2.01	1494	1 8 0		
8.8	195.75	2239	1.78	1553	2 0 0		
7.4	232.81	2601	1.53	1081	M 0 5 4 2 2 2 5 _ N _ _ _ . . . 3 3 B _ _	101.6	56C
6.6	260.47	2900	1.37	1081	2 5 0		
6.2	277.62	3090	1.29	1081	2 8 0		
5.6	305.72	3408	1.17	1081	3 0 0		
4.8	362.32	4021	0.99	1081	3 6 0		
4.1	416.75	4626	0.86	1081	4 0 0		
3.9	444.96	4931	0.81	1081	4 5 0		
12	143.39	1646	3.36	1618	M 0 6 3 2 1 2 5 _ N _ _ _ . . . 3 3 B _ _	83.9	56C
11	161.57	1854	2.99	1618	1 6 0		
9.2	187.83	2157	2.57	1618	1 8 0		
8.1	213.18	2443	2.27	1618	2 0 0		
8	215.23	2420	2.28	1618	M 0 6 4 2 2 2 5 _ N _ _ _ . . . 3 3 B _ _	112.6	56C
7.3	237.02	2668	2.07	1618	2 5 0		
6.3	272.91	3059	1.53	1618	2 8 0		
5.5	313.91	3517	1.33	1618	3 0 0		
4.7	365.1	4088	1.29	1618	3 6 0		
4.3	396.93	4444	1.19	1618	4 0 0		
3.9	444.1	4960	1.12	1618	4 5 0		
3.2	533.13	5951	0.93	1618	5 0 0		
3	568.23	6343	0.87	1618	6 5 0		
10	174.01	1993	3.85	2248	M 0 7 3 2 1 8 0 _ N _ _ _ . . . 3 3 B _ _	106	56C
8.8	195.15	2232	3.44	2248	2 0 0		
7.5	229	2575	2.98	1051	M 0 7 4 2 2 2 5 _ N _ _ _ . . . 3 3 B _ _	128	56C
6.6	259.68	2912	2.64	1051	2 5 0		
6	286.42	3211	2.39	1051	2 8 0		
5.5	315.41	3540	2.17	1051	3 0 0		
4.8	361.21	4046	1.9	1051	3 6 0		
4.2	415.49	4651	1.65	1051	4 0 0		
3.7	469.77	5247	1.46	1051	4 5 0		
3.4	510.72	5703	1.35	1051	5 0 0		
2.9	592.12	6594	1.16	1051	6 5 0		
2.4	710.84	7911	0.97	1051	7 3 0		
2	847.84	9402	0.82	1050	8 6 0		
5.7	301.21	3372	3.84	4017	M 0 8 4 2 2 8 0 _ N _ _ _ . . . 3 3 B _ _	231.6	56C
5.1	337.01	3769	3.44	4017	3 0 0		
4.8	359.19	4021	3.22	4017	3 6 0		
4.1	425.69	4765	2.72	4017	4 0 0		
3.6	480.51	5370	2.53	3775	4 5 0		
3.4	513.04	5734	2.37	3775	5 0 0		
2.8	621.92	6929	2.11	3407	6 5 0		
2.2	771.75	8597	1.7	3407	7 3 0		
1.9	900	9990	1.46	3407	8 6 0		
1.6	1061.28	11777	1.24	3407	1 0 C		
1.5	1165.78	12908	1.13	3407	1 1 C		
1.4	1276.51	14132	1.03	3407	1 3 C		
1.1	1564.35	17255	0.85	3407	1 5 C		

NOTE
Other output speeds are available using 2 and 6 pole motors - Consult Application Engineering

SERIES M

SELECTION TABLES

GEARED MOTORS

0.33 HP

4 POLE
1750 rpm
nominal
input speed

N2 R/MIN	i	M2 lb.in	Fm	lb	Unit Designation	lb	Motor Size
Output Speed	Ratio	Output Torque	Service Factor	Overhung Load	Column Entry 1 Through 20 Spaces to be filled when entering order	Weight of base mount unit	
2.8	624.45	7046	3.59	5609	M 0 9 4 1 6 5 0 _ N _ _ _ . 3 3 B - -	326.4	56C
2.3	736.35	8298	3.05	5609	7 3 0		
2	882.06	9903	2.55	5609	8 6 0		
1.7	1040.13	11667	2.17	5609	1 0 C		
1.5	1148.27	12876	1.96	5609	1 1 C		
1.3	1339.57	14930	1.69	5609	1 3 C		
1.1	1579.63	17598	1.44	5609	1 5 C		
0	1729.67	19263	1.31	5609	1 8 C		
0.81	2119.76	23580	1.07	5609	2 0 C		
0.73	2362.65	26271	0.96	5609	2 4 C		
0.65	2649.71	29430	0.86	5609	2 7 C		
0.66	2597.62	28466	0.89	5609	M 0 9 5 1 2 7 C _ N _ _ _ . 3 3 B - -	330.8	56C
0.71	2445.35	26603	1.47	9347	M 1 0 5 1 2 7 C _ N _ _ _ . 3 3 B - -	471.9	56C
0.57	3034.45	33019	1.18	9347	3 2 C		
0.48	3578.24	38924	1	9347	3 6 C		
0.44	3918.11	42604	0.92	9347	4 0 C		
0.68	2535.33	27593	2.04	14529	M 1 3 5 1 2 7 C _ N _ _ _ . 3 3 B - -	637.3	56C
0.55	3146.12	34227	1.64	14529	3 2 C		
0.46	3709.92	40332	1.39	14529	3 6 C		
0.42	4062.29	44137	1.27	14529	4 0 C		
0.38	4524.38	49027	1.15	14529	4 6 C		
0.31	5544.77	59989	0.94	14529	5 5 C		
0.63	2743.72	30052	3.14	18122	M 1 4 5 1 2 7 C _ N _ _ _ . 3 3 B - -	893	56C
0.51	3404.7	37254	2.53	18122	3 2 C		
0.43	4014.85	43878	2.15	18122	3 6 C		
0.39	4396.19	48006	1.96	18122	4 0 C		
0.35	4968.85	54042	1.66	18144	4 6 C		
0.32	5440.8	59132	1.51	18144	5 5 C		
0.26	6667.87	72312	1.24	18144	6 5 C		
0.23	7431.9	80516	1.11	18144	7 4 C		
0.21	8334.84	90132	0.99	18144	8 4 C		

0.5 HP

4 POLE
1750 rpm
nominal
input speed

460	3.75	66	7.46	356	M 0 1 2 2 3 . 6 _ N _ _ _ . 5 0 B - -	44	56C
341	5.07	89	6.29	373	5 . 0		
299	5.76	101	5.84	381	5 . 6		
264	6.53	115	5.39	390	6 . 3		
207	8.35	147	4.63	405	8 . 0		
192	9	158	4.36	408	9 . 0		
152	11.36	199	3.62	406	1 1 ,		
134	12.88	228	3.25	402	1 2 ,		
117	14.71	260	2.93	408	1 4 ,		
105	16.37	287	2.72	402	1 6 ,		
96	18.05	318	2.49	388	1 8 ,		
87	19.86	350	2.27	419	2 0 ,		
74	23.27	409	1.94	397	2 2 ,		
62	27.92	490	1.62	356	2 8 ,		
53	32.54	570	1.39	368	3 2 ,		
48	36.16	633	1.25	332	3 6 ,		
40	43.54	763	0.97	379	4 5 ,		
85	20.23	357	3.97	892	M 0 2 2 2 2 0 _ N _ _ _ . 5 0 B - -	50.7	56C
78	21.99	388	3.65	886	2 2 ,		
65	26.4	465	3.04	899	2 8 ,		
54	31.68	557	2.54	884	3 2 ,		
48	35.69	627	2.26	899	3 6 ,		
42	41.49	729	1.94	899	4 5 ,		
37	47.09	827	1.71	879	5 0 ,		
32	53.54	939	1.51	825	5 6 ,		
30	57.03	990	1.43	899	M 0 2 3 2 5 6 _ N _ _ _ . 5 0 B - -	52.9	56C
27	62.87	1093	1.3	876	6 3 ,		
25	69.19	1201	1.18	899	7 1 ,		
21	81.07	1405	1.01	899	8 0 ,		
18	97.26	1684	0.84	818	1 0 0		
65	26.4	466	3.97	869	M 0 3 2 2 2 8 _ N _ _ _ . 5 0 B - -	50.7	56C
54	31.68	555	3.33	831	3 2 ,		
48	35.69	624	2.96	854	3 6 ,		
42	41.49	727	2.37	809	4 5 ,		
37	47.09	828	2.14	879	5 0 ,		
32	53.54	940	1.94	825	5 6		

NOTE

Other output speeds are available using 2 and 6 pole motors - Consult Application Engineering

SERIES M

SELECTION TABLES

GEARED MOTORS

0.5 HP

4 POLE
1750 rpm
nominal
input speed

N2 R/MIN	i	M2 lb.in	Fm	lb	Unit Designation	lb	Motor Size
Output Speed	Ratio	Output Torque	Service Factor	Overhung Load	Column Entry 1 Through 20 Spaces to be filled when entering order	Weight of base mount unit	
30	57.03	989	1.87	800	M 0 3 3 2 5 6 . . N _ _ _ . . 5 0 B - -	52.9	56C
27	62.87	1093	1.69	750	6 3 ,		
25	69.19	1202	1.54	815	7 1 ,		
21	81.07	1407	1.31	704	8 0 .		
18	97.26	1686	1.1	818	1 0 0		
15	113.37	1965	0.94	616	1 1 2		
14	125.97	2179	0.85	458	1 2 5		
40	43.2	758	3.89	1611	M 0 4 2 2 4 5 . . N _ _ _ . . 5 0 B - -	68.3	56C
36	48.15	844	3.54	1608	5 0 ,		
32	54	948	2.52	1618	5 6 ,		
30	58.38	1013	2.83	1617	M 0 4 3 2 5 6 . . N _ _ _ . . 5 0 B - -	72.7	56C
27	64.29	1122	2.64	1609	6 3 ,		
23	73.95	1288	2.32	1618	7 1 ,		
21	80.4	1400	2.14	1618	8 0 .		
18	96.52	1678	1.78	1602	1 0 0		
15	115.82	2009	1.49	1617	1 1 2		
13	130.5	2263	1.32	1592	1 2 5		
11	151.71	2637	1.13	1618	1 6 0		
10	172.19	2985	1	1618	1 8 0		
8.8	195.75	3387	0.88	1566	2 0 0		
40	43.2	758	3.89	1544	M 0 5 2 2 4 5 . . N _ _ _ . . 5 0 B - -	70.5	56C
36	48.15	845	3.57	1590	5 0 ,		
32	54	948	2.52	1608	5 6 ,		
30	58.38	1017	3.91	1539	M 0 5 3 2 5 6 . . N _ _ _ . . 5 0 B - -	74.9	56C
27	64.29	1124	3.54	1508	6 3 ,		
23	73.95	1287	3.09	1528	7 1 ,		
21	80.4	1407	2.83	1493	8 0 .		
18	96.52	1681	2.37	1557	1 0 0		
15	115.82	2014	1.98	1440	1 1 2		
13	130.5	2268	1.76	1353	1 2 5		
11	151.71	2638	1.51	1370	1 6 0		
10	172.19	2995	1.33	1232	1 8 0		
8.8	195.75	3393	1.17	1416	2 0 0		
7.4	232.81	3941	1.01	1081	M 0 5 4 2 2 2 5 . . N _ _ _ . . 5 0 B - -	103.6	56C
6.6	260.47	4394	0.91	1081	2 5 0		
6.2	277.62	4682	0.85	1081	2 8 0		
29	59.61	1048	3.97	1618	M 0 6 2 2 5 6 . . N _ _ _ . . 5 0 B - -	81.5	56C
22	79.6	1392	3.78	1618	M 0 6 3 2 7 1 . . N _ _ _ . . 5 0 B - -	85.9	56C
19	91.56	1601	3.41	1618	8 0 .		
17	99.54	1732	3.2	1618	1 0 0		
14	119.5	2074	2.67	1618	1 1 2		
12	143.39	2494	2.22	1618	1 2 5		
11	161.57	2809	1.97	1618	1 6 0		
9.2	187.83	3269	1.69	1618	1 8 0		
8.1	213.18	3702	1.5	1618	2 0 0		
8	215.23	3667	1.51	1618	M 0 6 4 2 2 2 5 . . N _ _ _ . . 5 0 B - -	114.6	56C
7.3	237.02	4043	1.37	1618	2 5 0		
6.3	272.91	4635	1.01	1618	2 8 0		
5.5	313.91	5330	0.88	1618	3 0 0		
4.7	365.1	6195	0.85	1618	3 6 0		
15	116.34	2032	3.78	2248	M 0 7 3 2 1 1 2 . . N _ _ _ . . 5 0 B - -	108	56C
14	127.39	2218	3.46	2248	1 2 5		
11	156.12	2715	2.83	2248	1 6 0		
10	174.01	3020	2.54	2248	1 8 0		
8.8	195.15	3382	2.27	2248	2 0 0		
7.5	229	3901	1.97	1051	M 0 7 4 2 2 2 5 . . N _ _ _ . . 5 0 B - -	130	56C
6.6	259.68	4412	1.74	1051	2 5 0		
6	286.42	4865	1.58	1051	2 8 0		
5.5	315.41	5363	1.43	1051	3 0 0		
4.8	361.21	6130	1.25	1051	3 6 0		
4.2	415.49	7047	1.09	1051	4 0 0		
3.7	469.77	7951	0.97	1051	4 5 0		
3.4	510.72	8642	0.89	1051	5 0 0		

NOTE

Other output speeds are available using 2 and 6 pole motors - Consult Application Engineering

SERIES M

SELECTION TABLES

GEARED MOTORS

0.5 HP

4 POLE
1750 rpm
nominal
input speed

N2 R/MIN	i	M2 lb.in	Fm	lb	Unit Designation	lb	Motor Size
Output Speed	Ratio	Output Torque	Service Factor	Overhung Load	Column Entry 1 Through 20 Spaces to be filled when entering order	Weight of base mount unit	
7.5	228.91	3887	3.11	4252	M 0 8 4 2 2 2 5 _ N _ _ _ . 5 0 B - -	233.6	56C
6.7	258.98	4392	2.95	4017	2 5 0		
5.7	301.21	5109	2.54	4017	2 8 0		
5.1	337.01	5710	2.27	4017	3 0 0		
4.8	359.19	6093	2.13	4017	3 6 0		
4.1	425.69	7220	1.79	4017	4 0 0		
3.6	480.51	8137	1.67	3775	4 5 0		
3.4	513.04	8687	1.57	3775	5 0 0		
2.8	621.92	10499	1.39	3407	6 5 0		
2.2	771.75	13026	1.12	3407	7 3 0		
1.9	900	15136	0.97	3407	8 6 0		
1.6	1061.28	17845	0.82	3407	1 0 C		
4.1	424.23	7273	3.48	5609	M 0 9 4 1 4 0 0 _ N _ _ _ . 5 0 B - -	328.4	56C
3.7	471.32	8069	3.13	5609	4 5 0		
3.4	503.22	8613	2.94	5609	5 0 0		
2.8	624.45	10676	2.37	5609	6 5 0		
2.3	736.35	12574	2.01	5609	7 3 0		
2	882.06	15004	1.69	5609	8 6 0		
1.7	1040.13	17678	1.43	5609	1 0 C		
1.5	1148.27	19510	1.3	5609	1 1 C		
1.3	1339.57	22621	1.12	5609	1 3 C		
1.1	1579.63	26664	0.95	5609	1 5 C		
0	1729.67	29187	0.87	5609	1 8 C		
3	580.78	9884	3.95	9347	M 1 0 4 1 6 5 0 _ N _ _ _ . 5 0 B - -	467.3	56C
2.5	692.72	11776	3.32	9347	7 3 0		
2.1	828.21	14032	2.78	9347	8 6 0		
1.7	987.84	16726	2.34	9347	1 0 C		
1.5	1138.21	19222	2.03	9347	1 1 C		
1.4	1246.47	21040	1.86	9347	1 3 C		
1.1	1539.39	25805	1.46	9423	1 5 C		
1	1685.8	28254	1.33	9423	1 8 C		
0.85	2022.95	33872	1.11	9423	2 0 C		
0.74	2327.49	38969	0.97	9423	2 4 C		
0.67	2586.09	43256	0.87	9423	2 7 C		
0.71	2445.35	40308	0.97	9347	M 1 0 5 1 2 7 C _ N _ _ _ . 5 0 B - -	473.9	56C
2	858.69	14485	3.88	14529	M 1 3 4 1 8 6 0 _ N _ _ _ . 5 0 B - -	630.5	56C
1.7	1024.19	17261	3.26	14529	1 0 C		
1.5	1140.7	19184	2.93	14529	1 1 C		
1.4	1249.19	20996	2.68	14529	1 3 C		
1.1	1528.11	25593	2.24	14543	1 5 C		
0.94	1833.73	30662	1.87	14543	1 8 C		
0.82	2109.78	35258	1.62	14543	2 0 C		
0.74	2344.2	39122	1.46	14543	2 4 C		
0.6	2888.81	48252	1.19	14543	2 7 C		
0.68	2535.33	41808	1.34	14529	M 1 3 5 1 2 7 C _ N _ _ _ . 5 0 B - -	639.3	56C
0.55	3146.12	51859	1.08	14529	3 2 C		
0.46	3709.92	61109	0.92	14529	3 6 C		
0.42	4062.29	66874	0.84	14529	4 0 C		
1.1	1502.21	25281	3.54	18144	M 1 4 4 1 1 5 C _ N _ _ _ . 5 0 B - -	886.2	56C
0.96	1802.65	30278	2.96	18144	1 8 C		
0.83	2074.02	34808	2.57	18144	2 0 C		
0.75	2304.47	38617	2.32	18144	2 4 C		
0.61	2844.21	47617	1.72	18144	2 7 C		
0.63	2743.72	45534	2.07	18122	M 1 4 5 1 2 7 C _ N _ _ _ . 5 0 B - -	895	56C
0.51	3404.7	56445	1.67	18122	3 2 C		
0.43	4014.85	66481	1.42	18122	3 6 C		
0.39	4396.19	72736	1.3	18122	4 0 C		
0.35	4968.85	81882	1.09	18144	4 6 C		
0.32	5440.8	89594	1	18144	5 5 C		
0.26	6667.87	109563	0.82	18144	6 5 C		

NOTE

Other output speeds are available using 2 and 6 pole motors - Consult Application Engineering

SERIES M

SELECTION TABLES

GEARED MOTORS

0.75 HP

4 POLE
1750 rpm
nominal
input speed

N2 R/MIN	i	M2 lb.in	Fm	lb	Unit Designation	lb	Motor Size
Output Speed	Ratio	Output Torque	Service Factor	Overhung Load	Column Entry 1 Through 20 Spaces to be filled when entering order	Weight of base mount unit	
460	3.75	99	4.97	348	M 0 1 2 2 3 . 6 _ _ N _ _ _ _ . 7 5 B _ _	47	56C
341	5.07	133	4.19	363	5 . 0		
299	5.76	152	3.9	369	5 . 6		
264	6.53	173	3.6	377	6 . 3		
207	8.35	221	3.08	387	8 . 0		
192	9	238	2.91	389	9 . 0		
152	11.36	299	2.41	386	1 1 ,		
134	12.88	342	2.17	376	1 2 ,		
117	14.71	390	1.96	389	1 4 ,		
105	16.37	431	1.82	377	1 6 ,		
96	18.05	477	1.66	350	1 8 ,		
87	19.86	525	1.51	412	2 0 ,		
74	23.27	614	1.29	367	2 2 ,		
62	27.92	736	1.08	286	2 8 ,		
53	32.54	856	0.93	310	3 2 ,		
48	36.16	950	0.84	238	3 6 ,		
139	12.37	328	3.88	858	M 0 2 2 2 1 2 . _ _ N _ _ _ _ . 7 5 B _ _	53.7	56C
123	14.05	372	3.49	846	1 4 ,		
108	15.97	422	3.23	899	1 6 ,		
98	17.58	466	2.94	899	1 8 ,		
85	20.23	535	2.64	885	2 0 ,		
78	21.99	582	2.43	873	2 2 ,		
65	26.4	698	2.03	899	2 8 ,		
54	31.68	836	1.69	870	3 2 ,		
48	35.69	940	1.51	899	3 6 ,		
42	41.49	1094	1.29	899	4 5 ,		
37	47.09	1241	1.14	860	5 0 ,		
32	53.54	1409	1	752	5 6 ,		
30	57.03	1485	0.95	899	M 0 2 3 2 5 6 . _ _ N _ _ _ _ . 7 5 B _ _	55.9	56C
27	62.87	1639	0.86	854	6 3 ,		
98	17.58	466	3.74	899	M 0 3 2 2 1 8 . _ _ N _ _ _ _ . 7 5 B _ _	53.7	56C
85	20.23	535	3.4	885	2 0 ,		
78	21.99	583	3.17	873	2 2 ,		
65	26.4	699	2.64	840	2 8 ,		
54	31.68	832	2.22	763	3 2 ,		
48	35.69	937	1.97	809	3 6 ,		
42	41.49	1091	1.58	719	4 5 ,		
37	47.09	1243	1.42	860	5 0 ,		
32	53.54	1411	1.29	752	5 6 ,		
30	57.03	1484	1.25	702	M 0 3 3 2 5 6 . _ _ N _ _ _ _ . 7 5 B _ _	55.9	56C
27	62.87	1639	1.13	602	6 3 ,		
25	69.19	1803	1.03	732	7 1 ,		
21	81.07	2111	0.88	510	8 0 ,		
63	27.3	725	3.84	1562	M 0 4 2 2 2 8 . _ _ N _ _ _ _ . 7 5 B _ _	71.3	56C
54	32.19	851	3.35	1567	3 2 ,		
49	35.25	935	3.08	1570	3 6 ,		
40	43.2	1137	2.59	1604	4 5 ,		
36	48.15	1266	2.36	1598	5 0 ,		
32	54	1422	1.68	1618	5 6 ,		
30	58.38	1520	1.89	1615	M 0 4 3 2 5 6 . _ _ N _ _ _ _ . 7 5 B _ _	75.7	56C
27	64.29	1683	1.76	1599	6 3 ,		
23	73.95	1933	1.55	1618	7 1 ,		
21	80.4	2100	1.42	1618	8 0 ,		
18	96.52	2518	1.19	1587	1 0 0		
15	115.82	3014	0.99	1616	1 1 2		
13	130.5	3394	0.88	1566	1 2 5		
54	32.19	851	3.35	1558	M 0 5 2 2 3 2 . _ _ N _ _ _ _ . 7 5 B _ _	73.5	56C
49	35.25	935	3.08	1549	3 6 ,		
40	43.2	1137	2.59	1470	4 5 ,		
36	48.15	1268	2.38	1561	5 0 ,		
32	54	1422	1.68	1597	5 6 ,		
30	58.38	1526	2.61	1460	M 0 5 3 2 5 6 . _ _ N _ _ _ _ . 7 5 B _ _	77.9	56C
27	64.29	1686	2.36	1397	6 3 ,		
23	73.95	1931	2.06	1438	7 1 ,		
21	80.4	2111	1.89	1367	8 0 ,		
18	96.52	2522	1.58	1495	1 0 0		
15	115.82	3021	1.32	1263	1 1 2		
13	130.5	3403	1.17	1088	1 2 5		
11	151.71	3957	1.01	1123	1 6 0		
10	172.19	4492	0.89	846	1 8 0		

NOTE

Other output speeds are available using 2 and 6 pole motors - Consult Application Engineering

SERIES M

SELECTION TABLES

GEARED MOTORS

0.75 HP

4 POLE
1750 rpm
nominal
input speed

N2 R/MIN	i	M2 lb.in	Fm	lb	Unit Designation	lb	Motor Size
Output Speed	Ratio	Output Torque	Service Factor	Overhung Load	Column Entry 1 Through 20 Spaces to be filled when entering order	Weight of base mount unit	
32	53.49	1413	3.24	1618	M 0 6 2 2 5 0 . . N _ _ _ . 7 5 B - -	84.5	56C
29	59.61	1573	2.64	1618	5 6 ,		
24	72.28	1893	2.84	1618	M 0 6 3 2 6 3 . . N _ _ _ . 7 5 B - -	88.9	56C
22	79.6	2089	2.52	1618	7 1 ,		
19	91.56	2401	2.27	1618	8 0 ,		
17	99.54	2598	2.13	1618	1 0 0		
14	119.5	3112	1.78	1618	1 1 2		
12	143.39	3742	1.48	1618	1 2 5		
11	161.57	4213	1.31	1618	1 6 0		
9.2	187.83	4904	1.13	1618	1 8 0		
8.1	213.18	5554	1	1618	2 0 0		
8	215.23	5501	1.01	1618	M 0 6 4 2 2 2 5 _ N _ _ _ . 7 5 B - -	117.6	56C
7.3	237.02	6065	0.91	1618	2 5 0		
32	53.96	1416	3.72	2215	M 0 7 2 2 5 6 . . N _ _ _ . 7 5 B - -	102.2	56C
27	62.83	1642	3.9	2248	M 0 7 3 2 6 3 . . N _ _ _ . 7 5 B - -	111	56C
23	74.47	1950	3.47	2248	7 1 ,		
22	79.51	2077	3.33	2248	8 0 ,		
17	98.66	2575	2.89	2248	1 0 0		
15	116.34	3048	2.52	2248	1 1 2		
14	127.39	3327	2.31	2248	1 2 5		
11	156.12	4073	1.89	2248	1 6 0		
10	174.01	4531	1.7	2248	1 8 0		
7.5	229	5852	1.31	1051	M 0 7 4 2 2 2 5 _ N _ _ _ . 7 5 B - -	133	56C
6.6	259.68	6619	1.16	1051	2 5 0		
6	286.42	7298	1.05	1051	2 8 0		
5.5	315.41	8045	0.95	1051	3 0 0		
4.8	361.21	9195	0.84	1051	3 6 0		
11	160.45	4184	3.6	4496	M 0 8 3 2 1 6 0 _ N _ _ _ . 7 5 B - -	174.9	56C
10	175.21	4565	3.3	4496	1 8 0		
8.6	201.75	5237	2.87	4496	2 0 0		
7.5	228.91	5831	2.07	4252	M 0 8 4 2 2 2 5 _ N _ _ _ . 7 5 B - -	236.6	56C
6.7	258.98	6588	1.97	4017	2 5 0		
5.7	301.21	7664	1.69	4017	2 8 0		
5.1	337.01	8566	1.51	4017	3 0 0		
4.8	359.19	9140	1.42	4017	3 6 0		
4.1	425.69	10831	1.2	4017	4 0 0		
3.6	480.51	12206	1.12	3775	4 5 0		
3.4	513.04	13031	1.04	3775	5 0 0		
2.8	621.92	15749	0.93	3407	6 5 0		
7.5	231.06	5958	3.93	5780	M 0 9 4 1 2 2 5 _ N _ _ _ . 7 5 B - -	331.4	56C
6.7	258.09	6646	3.81	5609	2 5 0		
5.7	300.18	7728	3.27	5609	2 8 0		
5.1	335.85	8635	2.93	5609	3 0 0		
4.8	357.95	9212	2.75	5609	3 6 0		
4.1	424.23	10910	2.32	5609	4 0 0		
3.7	471.32	12104	2.09	5609	4 5 0		
3.4	503.22	12920	1.96	5609	5 0 0		
2.8	624.45	16014	1.58	5609	6 5 0		
2.3	736.35	18861	1.34	5609	7 3 0		
2	882.06	22507	1.12	5609	8 6 0		
1.7	1040.13	26517	0.95	5609	1 0 C		
1.5	1148.27	29265	0.86	5609	1 1 C		
4.3	398.71	10206	3.83	9347	M 1 0 4 1 4 0 0 _ N _ _ _ . 7 5 B - -	470.3	56C
3.9	443.06	11324	3.45	9347	4 5 0		
3.4	500.94	12797	3.05	9347	5 0 0		
3	580.78	14826	2.63	9347	6 5 0		
2.5	692.72	17665	2.21	9347	7 3 0		
2.1	828.21	21049	1.86	9347	8 6 0		
1.7	987.84	25089	1.56	9347	1 0 C		
1.5	1138.21	28833	1.35	9347	1 1 C		
1.4	1246.47	31561	1.24	9347	1 3 C		
1.1	1539.39	38707	0.97	9423	1 5 C		
1	1685.8	42381	0.89	9423	1 8 C		

NOTE

Other output speeds are available using 2 and 6 pole motors - Consult Application Engineering

SERIES M

SELECTION TABLES

GEARED MOTORS

0.75 HP	N2 R/MIN	i	M2 lb.in	Fm	lb	Unit Designation	lb	Motor Size	
	Output Speed	Ratio	Output Torque	Service Factor	Overhung Load	Column Entry 1 Through 20 Spaces to be filled when entering order	Weight of base mount unit		
4 POLE 1750 rpm nominal input speed	2.8	607.22	15475	3.63	14529	M 1 3 4 1 6 5 0 _ N _ _ _ . 7 5 B - -	633.5	56C	
	2.4	724.25	18436	3.05	14529	7 3 0			
	2	858.69	21728	2.59	14529	8 6 0			
	1.7	1024.19	25892	2.17	14529	1 0 C			
	1.5	1140.7	28776	1.95	14529	1 1 C			
	1.4	1249.19	31494	1.78	14529	1 3 C			
	1.1	1528.11	38390	1.49	14543	1 5 C			
	0.94	1833.73	45993	1.24	14543	1 8 C			
	0.82	2109.78	52887	1.08	14543	2 0 C			
	0.74	2344.2	58684	0.97	14543	2 4 C			
	0.68	2535.33	62712	0.9	14529	M 1 3 5 1 2 7 C _ N _ _ _ . 7 5 B - -	642.3	56C	
	1.6	1108.37	28079	3.36	18122	M 1 4 4 1 1 1 C _ N _ _ _ . 7 5 B - -	889.2	56C	
	1.4	1213.79	30726	3.07	18122	1 3 C			
	1.1	1502.21	37922	2.36	18144	1 5 C			
	0.96	1802.65	45417	1.97	18144	1 8 C			
	0.83	2074.02	52212	1.71	18144	2 0 C			
	0.75	2304.47	57926	1.54	18144	2 4 C			
	0.61	2844.21	71426	1.15	18144	2 7 C			
	0.63	2743.72	68301	1.38	18122	M 1 4 5 1 2 7 C _ N _ _ _ . 7 5 B - -	898	56C	
	0.51	3404.7	84668	1.11	18122	3 2 C			
	0.43	4014.85	99722	0.95	18122	3 6 C			
	0.39	4396.19	109104	0.86	18122	4 0 C			
	1.0 HP	460	3.75	132	3.73	340	M 0 1 2 2 3 . 6 _ N _ _ _ . 1 . 0 B - -	52	143TC
		341	5.07	178	3.15	353	5 . 0		
		299	5.76	203	2.92	357	5 . 6		
		264	6.53	231	2.7	363	6 . 3		
		207	8.35	294	2.31	370	8 . 0		
		192	9	317	2.18	371	9 . 0		
152		11.36	399	1.81	366	1 1 ,			
134		12.88	456	1.63	351	1 2 ,			
117		14.71	520	1.47	370	1 4 ,			
105		16.37	575	1.36	353	1 6 ,			
96		18.05	636	1.25	312	1 8 ,			
87		19.86	700	1.13	404	2 0 ,			
74		23.27	819	0.97	337	2 2 ,			
62		27.92	981	0.81	215	2 8 ,			
190		9.09	321	3.74	880	M 0 2 2 2 9 . 0 _ N _ _ _ . 1 . 0 B - -	58.7	143TC	
155		11.15	395	3.16	853	1 1 ,			
139		12.37	438	2.91	837	1 2 ,			
123		14.05	497	2.62	819	1 4 ,			
108		15.97	563	2.42	899	1 6 ,			
98		17.58	621	2.21	899	1 8 ,			
85		20.23	714	1.98	878	2 0 ,			
78		21.99	776	1.82	860	2 2 ,			
65		26.4	931	1.52	899	2 8 ,			
54		31.68	1114	1.27	856	3 2 ,			
48		35.69	1254	1.13	899	3 6 ,			
42		41.49	1459	0.97	899	4 5 ,			
37		47.09	1655	0.86	840	5 0 ,			
155		11.15	395	3.81	782	M 0 3 2 2 1 1 _ _ N _ _ _ . 1 . 0 B - -	58.7	143TC	
139		12.37	438	3.56	837	1 2 ,			
123		14.05	496	3.27	819	1 4 ,			
108		15.97	564	3.04	899	1 6 ,			
98		17.58	622	2.8	899	1 8 ,			
85	20.23	714	2.55	878	2 0 ,				
78	21.99	777	2.38	860	2 2 ,				
65	26.4	932	1.98	810	2 8 ,				
54	31.68	1110	1.67	695	3 2 ,				
48	35.69	1249	1.48	764	3 6 ,				
42	41.49	1455	1.19	629	4 5 ,				
37	47.09	1657	1.07	840	5 0 ,				
32	53.54	1881	0.97	679	5 6 ,				
30	57.03	1979	0.93	604	M 0 3 3 2 5 6 _ _ N _ _ _ . 1 . 0 B - -	60.9	143TC		
27	62.87	2186	0.85	454	6 3 ,				
84	20.61	730	3.64	1420	M 0 4 2 2 2 0 _ _ N _ _ _ . 1 . 0 B - -	76.3	143TC		
78	22	777	3.45	1466	2 2 ,				
63	27.3	967	2.88	1534	2 8 ,				
54	32.19	1134	2.51	1542	3 2 ,				
49	35.25	1247	2.31	1545	3 6 ,				
40	43.2	1516	1.94	1597	4 5 ,				
36	48.15	1688	1.77	1588	5 0 ,				
32	54	1896	1.26	1618	5 6 ,				

NOTE

Other output speeds are available using 2 and 6 pole motors - Consult Application Engineering

SERIES M

SELECTION TABLES

GEARED MOTORS

1.0 HP

4 POLE
1750 rpm
nominal
input speed

N2 R/MIN	i	M2 lb.in	Fm	lb	Unit Designation	lb	Motor Size
Output Speed	Ratio	Output Torque	Service Factor	Overhung Load	Column Entry 1 Through 20 Spaces to be filled when entering order	Weight of base mount unit	
30	58.38	2027	1.41	1614	M 0 4 3 2 5 6 . . N _ _ _ _ 1 . 0 B - -	80.7	143TC
27	64.29	2245	1.32	1590	6 3 ,		
23	73.95	2577	1.16	1618	7 1 ,		
21	80.4	2800	1.07	1618	8 0 ,		
18	96.52	3357	0.89	1571	1 0 0		
54	32.19	1134	2.51	1528	M 0 5 2 2 3 2 . . N _ _ _ _ 1 . 0 B - -	78.5	143TC
49	35.25	1247	2.31	1515	3 6 ,		
40	43.2	1516	1.94	1396	4 5 ,		
36	48.15	1691	1.78	1533	5 0 ,		
32	54	1896	1.26	1587	5 6 ,		
30	58.38	2035	1.96	1381	M 0 5 3 2 5 6 . . N _ _ _ _ 1 . 0 B - -	82.9	143TC
27	64.29	2248	1.77	1287	6 3 ,		
23	73.95	2575	1.55	1347	7 1 ,		
21	80.4	2815	1.41	1242	8 0 ,		
18	96.52	3362	1.18	1434	1 0 0		
15	115.82	4028	0.99	1086	1 1 2		
13	130.5	4537	0.88	823	1 2 5		
43	39.86	1406	3.94	1606	M 0 6 2 2 3 6 . . N _ _ _ _ 1 . 0 B - -	89.5	143TC
40	43.64	1540	3.6	1618	4 5 ,		
32	53.49	1884	2.43	1618	5 0 ,		
29	59.61	2097	1.98	1618	5 6 ,		
24	72.28	2524	2.13	1618	M 0 6 3 2 6 3 . . N _ _ _ _ 1 . 0 B - -	93.9	143TC
22	79.6	2785	1.89	1618	7 1 ,		
19	91.56	3202	1.71	1618	8 0 ,		
17	99.54	3464	1.6	1618	1 0 0		
14	119.5	4149	1.34	1618	1 1 2		
12	143.39	4989	1.11	1618	1 2 5		
11	161.57	5618	0.99	1618	1 6 0		
9.2	187.83	6538	0.85	1618	1 8 0		
36	48.56	1704	3.64	2229	M 0 7 2 2 5 0 . . N _ _ _ _ 1 . 0 B - -	107.2	143TC
32	53.96	1888	2.79	2183	5 6 ,		
29	58.95	2054	3.07	2248	M 0 7 3 2 5 6 . . N _ _ _ _ 1 . 0 B - -	116	143TC
27	62.83	2190	2.92	2248	6 3 ,		
23	74.47	2600	2.6	2248	7 1 ,		
22	79.51	2770	2.5	2248	8 0 ,		
17	98.66	3433	2.17	2248	1 0 0		
15	116.34	4064	1.89	2248	1 1 2		
14	127.39	4436	1.73	2248	1 2 5		
7.5	229	7803	0.98	1051	M 0 7 4 2 2 2 5 _ N _ _ _ _ 1 . 0 B - -	138	143TC
6.6	259.68	8825	0.87	1051	2 5 0		
14	119.19	4139	3.64	4496	M 0 8 3 2 1 1 2 _ N _ _ _ _ 1 . 0 B - -	179.9	143TC
13	130.92	4553	3.3	4496	1 2 5		
11	160.45	5579	2.7	4496	1 6 0		
10	175.21	6086	2.47	4496	1 8 0		
8.6	201.75	6983	2.15	4496	2 0 0		
7.5	228.91	7775	1.55	4252	M 0 8 4 2 2 2 5 _ N _ _ _ _ 1 . 0 B - -	241.6	143TC
6.7	258.98	8785	1.47	4017	2 5 0		
5.7	301.21	10219	1.27	4017	2 8 0		
5.1	337.01	11421	1.13	4017	3 0 0		
4.8	359.19	12187	1.06	4017	3 6 0		
4.1	425.69	14441	0.9	4017	4 0 0		
3.6	480.51	16275	0.84	3775	4 5 0		
11	160.29	5568	3.93	6658	M 0 9 3 1 1 6 0 _ N _ _ _ _ 1 . 0 B - -	292.3	143TC
7.5	231.06	7944	2.95	5780	M 0 9 4 1 2 2 5 _ N _ _ _ _ 1 . 0 B - -	336.4	143TC
6.7	258.09	8862	2.85	5609	2 5 0		
5.7	300.18	10304	2.45	5609	2 8 0		
5.1	335.85	11513	2.2	5609	3 0 0		
4.8	357.95	12283	2.06	5609	3 6 0		
4.1	424.23	14547	1.74	5609	4 0 0		
3.7	471.32	16139	1.57	5609	4 5 0		
3.4	503.22	17226	1.47	5609	5 0 0		
2.8	624.45	21352	1.18	5609	6 5 0		
2.3	736.35	25148	1.01	5609	7 3 0		
2	882.06	30009	0.84	5609	8 6 0		

NOTE
Other output speeds are available using 2 and 6 pole motors - Consult Application Engineering

SERIES M

SELECTION TABLES

GEARED MOTORS

1.0 HP

4 POLE
1750 rpm
nominal
input speed

N2 R/MIN	i	M2 lb.in	Fm	lb	Unit Designation	lb	Motor Size
Output Speed	Ratio	Output Torque	Service Factor	Overhung Load	Column Entry 1 Through 20 Spaces to be filled when entering order	Weight of base mount unit	
5.5	315.65	10769	3.63	9347	M 1 0 4 1 3 0 0 _ N _ _ _ _ 1 . 0 B - -	475.3	143TC
5	348.16	11887	3.29	9347	3 6 0		
4.3	398.71	13608	2.87	9347	4 0 0		
3.9	443.06	15099	2.59	9347	4 5 0		
3.4	500.94	17062	2.29	9347	5 0 0		
3	580.78	19768	1.98	9347	6 5 0		
2.5	692.72	23553	1.66	9347	7 3 0		
2.1	828.21	28065	1.39	9347	8 6 0		
1.7	987.84	33452	1.17	9347	1 0 C		
1.5	1138.21	38444	1.02	9347	1 1 C		
1.4	1246.47	42081	0.93	9347	1 3 C		
3.7	463.22	15764	3.56	14529	M 1 3 4 1 4 5 0 _ N _ _ _ _ 1 . 0 B - -	638.5	143TC
3.3	523.74	17812	3.15	14529	5 0 0		
2.8	607.22	20633	2.72	14529	6 5 0		
2.4	724.25	24581	2.29	14529	7 3 0		
2	858.69	28970	1.94	14529	8 6 0		
1.7	1024.19	34522	1.63	14529	1 0 C		
1.5	1140.7	38368	1.46	14529	1 1 C		
1.4	1249.19	41992	1.34	14529	1 3 C		
1.1	1528.11	51187	1.12	14543	1 5 C		
0.94	1833.73	61324	0.93	14543	1 8 C		
0.82	2109.78	70516	0.81	14543	2 0 C		
2.2	770.01	26138	3.65	18122	M 1 4 4 1 7 3 0 _ N _ _ _ _ 1 . 0 B - -	894.2	143TC
2.2	801.52	27128	3.48	18122	8 6 0		
1.9	929.27	31426	3	18122	1 0 C		
1.6	1108.37	37439	2.52	18122	1 1 C		
1.4	1213.79	40968	2.3	18122	1 3 C		
1.1	1502.21	50563	1.77	18144	1 5 C		
0.96	1802.65	60556	1.48	18144	1 8 C		
0.83	2074.02	69617	1.29	18144	2 0 C		
0.75	2304.47	77234	1.16	18144	2 4 C		
0.61	2844.21	95234	0.86	18144	2 7 C		
0.63	2743.72	91068	1.04	18122	M 1 4 5 1 2 7 C _ N _ _ _ _ 1 . 0 B - -	903	143TC
0.51	3404.7	112890	0.84	18122	3 2 C		

1.5 HP

4 POLE
1750 rpm
nominal
input speed

460	3.75	198	2.49	325	M 0 1 2 2 3 . 6 _ N _ _ _ _ 1 . 5 B - -	56	145TC
341	5.07	267	2.1	332	5 . 0		
299	5.76	304	1.95	334	5 . 6		
264	6.53	346	1.8	336	6 . 3		
207	8.35	442	1.54	335	8 . 0		
192	9	476	1.45	333	9 . 0		
152	11.36	599	1.21	325	1 1 ,		
134	12.88	684	1.08	301	1 2 ,		
117	14.71	780	0.98	332	1 4 ,		
105	16.37	862	0.91	303	1 6 ,		
96	18.05	955	0.83	236	1 8 ,		
343	5.03	267	3.61	853	M 0 2 2 2 5 . 0 _ N _ _ _ _ 1 . 5 B - -	62.7	145TC
311	5.55	293	3.41	842	5 . 6		
274	6.3	332	3.16	825	6 . 3		
216	8	424	2.73	785	8 . 0		
190	9.09	482	2.49	868	9 . 0		
155	11.15	592	2.11	823	1 1 ,		
139	12.37	657	1.94	797	1 2 ,		
123	14.05	745	1.74	766	1 4 ,		
108	15.97	845	1.61	899	1 6 ,		
98	17.58	932	1.47	899	1 8 ,		
85	20.23	1071	1.32	865	2 0 ,		
78	21.99	1164	1.22	834	2 2 ,		
65	26.4	1397	1.01	899	2 8 ,		
54	31.68	1672	0.85	827	3 2 ,		

NOTE

Other output speeds are available using 2 and 6 pole motors - Consult Application Engineering

SERIES M

SELECTION TABLES

GEARED MOTORS

1.5 HP

4 POLE
1750 rpm
nominal
input speed

N2 R/MIN	i	M2 lb.in	Fm	lb	Unit Designation	lb	Motor Size
Output Speed	Ratio	Output Torque	Service Factor	Overhung Load	Column Entry 1 Through 20 Spaces to be filled when entering order	Weight of base mount unit	
311	5.55	294	3.99	842	M 0 3 2 2 5 . 6 _ _ N _ _ _ _ 1 . 5 B _ _	62.7	145TC
274	6.3	333	3.69	825	6 . 3		
216	8	425	3.16	785	8 . 0		
190	9.09	483	2.91	758	9 . 0		
155	11.15	592	2.54	704	1 1 ,		
139	12.37	657	2.37	797	1 2 ,		
123	14.05	744	2.18	766	1 4 ,		
108	15.97	847	2.03	899	1 6 ,		
98	17.58	933	1.87	899	1 8 ,		
85	20.23	1071	1.7	865	2 0 ,		
78	21.99	1166	1.59	834	2 2 ,		
65	26.4	1399	1.32	751	2 8 ,		
54	31.68	1665	1.11	560	3 2 ,		
48	35.69	1874	0.99	674	3 6 ,		
138	12.54	666	3.53	1247	M 0 4 2 2 1 2 _ _ N _ _ _ _ 1 . 5 B _ _	80.3	145TC
118	14.58	774	3.16	1276	1 4 ,		
106	16.31	865	2.93	1307	1 6 ,		
99	17.39	922	2.8	1329	1 8 ,		
84	20.61	1095	2.42	1360	2 0 ,		
78	22	1165	2.3	1416	2 2 ,		
63	27.3	1451	1.92	1477	2 8 ,		
54	32.19	1702	1.67	1491	3 2 ,		
49	35.25	1870	1.54	1497	3 6 ,		
40	43.2	2275	1.3	1583	4 5 ,		
36	48.15	2533	1.18	1568	5 0 ,		
32	54	2845	0.84	1618	5 6 ,		
30	58.38	3041	0.94	1611	M 0 4 3 2 5 6 _ _ N _ _ _ _ 1 . 5 B _ _	84.7	145TC
27	64.29	3367	0.88	1571	6 3 ,		
84	20.61	1094	3.64	1298	M 0 5 2 2 2 0 _ _ N _ _ _ _ 1 . 5 B _ _	82.5	145TC
78	22	1167	3.41	1302	2 2 ,		
63	27.3	1448	2.75	1301	2 8 ,		
54	32.19	1702	1.67	1468	3 2 ,		
49	35.25	1870	1.54	1446	3 6 ,		
40	43.2	2275	1.3	1249	4 5 ,		
36	48.15	2536	1.19	1477	5 0 ,		
32	54	2845	0.84	1566	5 6 ,		
30	58.38	3053	1.3	1223	M 0 5 3 2 5 6 _ _ N _ _ _ _ 1 . 5 B _ _	86.9	145TC
27	64.29	3372	1.18	1067	6 3 ,		
23	73.95	3862	1.03	1167	7 1 ,		
21	80.4	4223	0.94	992	8 0 ,		
63	27.24	1448	3.82	1618	M 0 6 2 2 2 8 _ _ N _ _ _ _ 1 . 5 B _ _	93.5	145TC
51	33.8	1796	3.08	1618	3 2 ,		
43	39.86	2109	2.63	1598	3 6 ,		
40	43.64	2311	2.4	1618	4 5 ,		
32	53.49	2827	1.62	1618	5 0 ,		
29	59.61	3146	1.32	1618	5 6 ,		
24	72.28	3786	1.42	1618	M 0 6 3 2 6 3 _ _ N _ _ _ _ 1 . 5 B _ _	97.9	145TC
22	79.6	4178	1.26	1618	7 1 ,		
19	91.56	4803	1.14	1618	8 0 ,		
17	99.54	5196	1.07	1618	1 0 0		
14	119.5	6224	0.89	1618	1 1 2		
49	35.17	1861	3.96	1972	M 0 7 2 2 3 6 _ _ N _ _ _ _ 1 . 5 B _ _	111.2	145TC
41	42.21	2226	3.37	2015	4 5 ,		
36	48.56	2556	2.42	2211	5 0 ,		
32	53.96	2832	1.86	2118	5 6 ,		
29	58.95	3082	2.04	2248	M 0 7 3 2 5 6 _ _ N _ _ _ _ 1 . 5 B _ _	120	145TC
27	62.83	3285	1.95	2248	6 3 ,		
23	74.47	3900	1.74	2248	7 1 ,		
22	79.51	4155	1.67	2248	8 0 ,		
26	66.02	3458	3.99	4496	M 0 8 3 2 6 3 _ _ N _ _ _ _ 1 . 5 B _ _	183.9	145TC
23	74.69	3887	3.67	4496	7 1 ,		
20	84.31	4390	3.37	4496	8 0 ,		
17	102.2	5335	2.82	4496	1 0 0		
14	119.19	6208	2.42	4496	1 1 2		
13	130.92	6829	2.2	4496	1 2 5		
11	160.45	8369	1.8	4496	1 6 0		
10	175.21	9130	1.65	4496	1 8 0		

NOTE

Other output speeds are available using 2 and 6 pole motors - Consult Application Engineering

SERIES M

SELECTION TABLES

GEARED MOTORS

1.5 HP

4 POLE
1750 rpm
nominal
input speed

N2 R/MIN	i	M2 lb.in	Fm	lb	Unit Designation	lb	Motor Size
Output Speed	Ratio	Output Torque	Service Factor	Overhung Load	Column Entry 1 Through 20 Spaces to be filled when entering order	Weight of base mount unit	
7.5	228.91	11663	1.04	4252	M 0 8 4 2 2 2 5 _ N _ _ _ _ 1 . 5 B - -	245.6	145TC
6.7	258.98	13177	0.98	4017	2 5 0		
5.7	301.21	15328	0.85	4017	2 8 0		
13	128.66	6742	3.75	6639	M 0 9 3 1 1 2 5 _ N _ _ _ _ 1 . 5 B - -	296.3	145TC
12	145.2	7563	2.89	6629	1 4 0		
11	160.29	8352	2.62	6618	1 6 0		
7.5	231.06	11917	1.96	5780	M 0 9 4 1 2 2 5 _ N _ _ _ _ 1 . 5 B - -	340.4	145TC
6.7	258.09	13293	1.9	5609	2 5 0		
5.7	300.18	15457	1.64	5609	2 8 0		
5.1	335.85	17270	1.46	5609	3 0 0		
4.8	357.95	18425	1.37	5609	3 6 0		
4.1	424.23	21820	1.16	5609	4 0 0		
3.7	471.32	24208	1.04	5609	4 5 0		
3.4	503.22	25840	0.98	5609	5 0 0		
7.8	220.22	11288	3.46	9347	M 1 0 4 1 2 2 5 _ N _ _ _ _ 1 . 5 B - -	479.3	145TC
7.1	242.24	12416	3.15	9347	2 5 0		
6.2	278.36	14263	2.74	9347	2 8 0		
5.5	315.65	16154	2.42	9347	3 0 0		
5	348.16	17831	2.19	9347	3 6 0		
4.3	398.71	20413	1.91	9347	4 0 0		
3.9	443.06	22649	1.72	9347	4 5 0		
3.4	500.94	25594	1.53	9347	5 0 0		
3	580.78	29652	1.32	9347	6 5 0		
2.5	692.72	35330	1.11	9347	7 3 0		
2.1	828.21	42098	0.93	9347	8 6 0		
6	286.9	14672	3.83	14529	M 1 3 4 1 2 8 0 _ N _ _ _ _ 1 . 5 B - -	642.5	145TC
5.3	325.33	16614	3.38	14529	3 0 0		
4.8	358.84	18338	3.06	14529	3 6 0		
4.2	410.95	20991	2.68	14529	4 0 0		
3.7	463.22	23646	2.38	14529	4 5 0		
3.3	523.74	26718	2.1	14529	5 0 0		
2.8	607.22	30950	1.82	14529	6 5 0		
2.4	724.25	36872	1.52	14529	7 3 0		
2	858.69	43456	1.29	14529	8 6 0		
1.7	1024.19	51784	1.09	14529	1 0 C		
1.5	1140.7	57552	0.98	14529	1 1 C		
1.4	1249.19	62988	0.89	14529	1 3 C		
3.5	492.49	25156	3.79	18122	M 1 4 4 1 4 5 0 _ N _ _ _ _ 1 . 5 B - -	898.2	145TC
3.1	556.83	28420	3.35	18122	5 0 0		
2.7	645.58	32917	2.9	18122	6 5 0		
2.2	770.01	39208	2.43	18122	7 3 0		
2.2	801.52	40693	2.32	18122	8 6 0		
1.9	929.27	47139	2	18122	1 0 C		
1.6	1108.37	56159	1.68	18122	1 1 C		
1.4	1213.79	61453	1.53	18122	1 3 C		
1.1	1502.21	75845	1.18	18144	1 5 C		
0.96	1802.65	90834	0.99	18144	1 8 C		
0.83	2074.02	104425	0.86	18144	2 0 C		

2.0 HP

4 POLE
1750 rpm
nominal
input speed

460	3.75	264	1.86	309	M 0 1 2 2 3 . 6 _ N _ _ _ _ 2 . 0 B - -	63	145TC
341	5.07	357	1.57	311	5 . 0		
299	5.76	406	1.46	310	5 . 6		
264	6.53	462	1.35	308	6 . 3		
207	8.35	589	1.16	301	8 . 0		
192	9	634	1.09	296	9 . 0		
152	11.36	799	0.91	285	1 1 ,		
134	12.88	912	0.81	251	1 2 ,		
481	3.59	253	3.29	813	M 0 2 2 2 3 . 6 _ N _ _ _ _ 2 . 0 B - -	69.7	145TC
343	5.03	356	2.71	834	5 . 0		
311	5.55	391	2.56	819	5 . 6		
274	6.3	443	2.37	796	6 . 3		
216	8	565	2.05	740	8 . 0		
190	9.09	643	1.87	856	9 . 0		
155	11.15	790	1.58	793	1 1 ,		
139	12.37	876	1.45	756	1 2 ,		
123	14.05	994	1.31	713	1 4 ,		
108	15.97	1126	1.21	899	1 6 ,		
98	17.58	1242	1.1	899	1 8 ,		
85	20.23	1428	0.99	851	2 0 ,		
78	21.99	1552	0.91	809	2 2 ,		

NOTE
Other output
speeds are
available
using 2 and 6
pole motors
- Consult
Application
Engineering

SERIES M

SELECTION TABLES

GEARED MOTORS

2.0 HP

4 POLE
1750 rpm
nominal
input speed

N2 R/MIN	i	M2 lb.in	Fm	lb	Unit Designation	lb	Motor Size
Output Speed	Ratio	Output Torque	Service Factor	Overhung Load	Column Entry 1 Through 20 Spaces to be filled when entering order	Weight of base mount unit	
481	3.59	253	3.91	813	M 0 3 2 2 3 . 6 _ N _ _ _ _ 2 . 0 B _ _	69.7	145TC
343	5.03	356	3.18	834	5 . 0		
311	5.55	393	2.99	819	5 . 6		
274	6.3	444	2.77	796	6 . 3		
216	8	566	2.37	740	8 . 0		
190	9.09	645	2.18	702	9 . 0		
155	11.15	790	1.9	626	1 1 ,		
139	12.37	876	1.78	756	1 2 ,		
123	14.05	992	1.63	713	1 4 ,		
108	15.97	1129	1.52	899	1 6 ,		
98	17.58	1244	1.4	899	1 8 ,		
85	20.23	1429	1.28	851	2 0 ,		
78	21.99	1554	1.19	809	2 2 ,		
65	26.4	1865	0.99	692	2 8 ,		
54	31.68	2221	0.83	424	3 2 ,		
138	12.54	888	2.65	1218	M 0 4 2 2 1 2 _ _ N _ _ _ _ 2 . 0 B _ _	87.3	145TC
118	14.58	1033	2.37	1243	1 4 ,		
106	16.31	1154	2.2	1269	1 6 ,		
99	17.39	1229	2.1	1289	1 8 ,		
84	20.61	1460	1.82	1300	2 0 ,		
78	22	1554	1.73	1366	2 2 ,		
63	27.3	1934	1.44	1421	2 8 ,		
54	32.19	2269	1.26	1440	3 2 ,		
49	35.25	2494	1.16	1448	3 6 ,		
40	43.2	3033	0.97	1569	4 5 ,		
36	48.15	3377	0.89	1548	5 0 ,		
118	14.58	1035	3.85	1198	M 0 5 2 2 1 4 _ _ N _ _ _ _ 2 . 0 B _ _	89.5	145TC
106	16.31	1156	3.44	1222	1 6 ,		
99	17.39	1232	3.23	1243	1 8 ,		
84	20.61	1459	2.73	1235	2 0 ,		
78	22	1557	2.56	1229	2 2 ,		
63	27.3	1931	2.06	1185	2 8 ,		
54	32.19	2269	1.26	1408	3 2 ,		
49	35.25	2494	1.16	1377	3 6 ,		
40	43.2	3033	0.97	1101	4 5 ,		
36	48.15	3382	0.89	1420	5 0 ,		
30	58.38	4071	0.98	1065	M 0 5 3 2 5 6 _ _ N _ _ _ _ 2 . 0 B _ _	93.9	145TC
27	64.29	4497	0.89	846	6 3 ,		
85	20.2	1432	3.87	1618	M 0 6 2 2 1 8 _ _ N _ _ _ _ 2 . 0 B _ _	100.5	145TC
80	21.53	1526	3.63	1618	2 0 ,		
68	25.51	1810	3.06	1618	2 2 ,		
63	27.24	1931	2.87	1618	2 8 ,		
51	33.8	2395	2.31	1618	3 2 ,		
43	39.86	2813	1.97	1590	3 6 ,		
40	43.64	3081	1.8	1618	4 5 ,		
32	53.49	3769	1.22	1618	5 0 ,		
29	59.61	4195	0.99	1618	5 6 ,		
24	72.28	5048	1.06	1618	M 0 6 3 2 6 3 _ _ N _ _ _ _ 2 . 0 B _ _	104.9	145TC
22	79.6	5571	0.95	1618	7 1 ,		
19	91.56	6404	0.85	1618	8 0 ,		
64	26.93	1899	3.77	1893	M 0 7 2 2 2 8 _ _ N _ _ _ _ 2 . 0 B _ _	118.2	145TC
54	32.12	2265	3.22	1882	3 2 ,		
49	35.17	2481	2.97	1835	3 6 ,		
41	42.21	2969	2.52	1899	4 5 ,		
36	48.56	3408	1.82	2192	5 0 ,		
32	53.96	3776	1.39	2054	5 6 ,		
31	55.8	3914	3.44	4243	M 0 8 2 2 5 6 _ _ N _ _ _ _ 2 . 0 B _ _	195.3	145TC
29	60.33	4177	3.2	4496	M 0 8 3 2 5 6 _ _ N _ _ _ _ 2 . 0 B _ _	190.9	145TC
26	66.02	4611	2.99	4496	6 3 ,		
23	74.69	5182	2.75	4496	7 1 ,		
20	84.31	5854	2.52	4496	8 0 ,		
17	102.2	7114	2.11	4496	1 0 0		
18	93.92	6559	3.56	6646	M 0 9 3 1 9 0 _ _ N _ _ _ _ 2 . 0 B _ _	303.3	145TC
17	103.68	7244	3.23	6639	1 0 0		
15	116.55	8148	3.11	6631	1 1 2		
13	128.66	8990	2.82	6609	1 2 5		
12	145.2	10084	2.17	6594	1 4 0		
11	160.29	11136	1.96	6578	1 6 0		

NOTE
Other output
speeds are
available
using 2 and 6
pole motors
- Consult
Application
Engineering

SERIES M

SELECTION TABLES

GEARED MOTORS

2.0 HP

4 POLE
1750 rpm
nominal
input speed

N2 R/MIN	i	M2 lb.in	Fm	lb	Unit Designation	lb	Motor Size
Output Speed	Ratio	Output Torque	Service Factor	Overhung Load	Column Entry 1 Through 20 Spaces to be filled when entering order	Weight of base mount unit	
7.5	231.06	15889	1.47	5780	M 0 9 4 1 2 2 5 _ N _ _ _ 2 . 0 B _ _	347.4	145TC
6.7	258.09	17725	1.43	5609	2 5 0		
5.7	300.18	20609	1.23	5609	2 8 0		
5.1	335.85	23027	1.1	5609	3 0 0		
4.8	357.95	24566	1.03	5609	3 6 0		
4.1	424.23	29094	0.87	5609	4 0 0		
7.8	220.22	15051	2.59	9347	M 1 0 4 1 2 2 5 _ N _ _ _ 2 . 0 B _ _	486.3	145TC
7.1	242.24	16554	2.36	9347	2 5 0		
6.2	278.36	19018	2.05	9347	2 8 0		
5.5	315.65	21538	1.81	9347	3 0 0		
5	348.16	23775	1.64	9347	3 6 0		
4.3	398.71	27217	1.43	9347	4 0 0		
3.9	443.06	30198	1.29	9347	4 5 0		
3.4	500.94	34125	1.14	9347	5 0 0		
3	580.78	39536	0.99	9347	6 5 0		
2.5	692.72	47106	0.83	9347	7 3 0		
7.6	226.98	15485	3.63	14529	M 1 3 4 1 2 2 5 _ N _ _ _ 2 . 0 B _ _	649.5	145TC
6.9	249.68	17030	3.3	14529	2 5 0		
6	286.9	19562	2.87	14529	2 8 0		
5.3	325.33	22153	2.54	14529	3 0 0		
4.8	358.84	24451	2.3	14529	3 6 0		
4.2	410.95	27988	2.01	14529	4 0 0		
3.7	463.22	31528	1.78	14529	4 5 0		
3.3	523.74	35624	1.58	14529	5 0 0		
2.8	607.22	41267	1.36	14529	6 5 0		
2.4	724.25	49162	1.14	14529	7 3 0		
2	858.69	57941	0.97	14529	8 6 0		
1.7	1024.19	69045	0.81	14529	1 0 C		
4.9	353.64	24106	3.89	18122	M 1 4 4 1 3 0 0 _ N _ _ _ 2 . 0 B _ _	905.2	145TC
4.4	390.06	26605	3.52	18122	3 6 0		
3.9	446.71	30450	3.08	18122	4 0 0		
3.5	492.49	33541	2.84	18122	4 5 0		
3.1	556.83	37894	2.52	18122	5 0 0		
2.7	645.58	43889	2.17	18122	6 5 0		
2.2	770.01	52277	1.82	18122	7 3 0		
2.2	801.52	54257	1.74	18122	8 6 0		
1.9	929.27	62852	1.5	18122	1 0 C		
1.6	1108.37	74879	1.26	18122	1 1 C		
1.4	1213.79	81937	1.15	18122	1 3 C		
1.1	1502.21	101127	0.88	18144	1 5 C		

3.0 HP

4 POLE
1750 rpm
nominal
input speed

460	3.75	396	1.24	278	M 0 1 2 2 3 . 6 _ N _ _ _ 3 . 0 B _ _	85.3	182TC
341	5.07	535	1.05	269	5 . 0		
299	5.76	609	0.97	263	5 . 6		
264	6.53	693	0.9	254	6 . 3		
481	3.59	379	2.19	790	M 0 2 2 2 3 . 6 _ N _ _ _ 3 . 0 B _ _	94.1	182TC
343	5.03	534	1.81	797	5 . 0		
311	5.55	586	1.71	774	5 . 6		
274	6.3	665	1.58	737	6 . 3		
216	8	848	1.37	649	8 . 0		
190	9.09	965	1.25	831	9 . 0		
155	11.15	1185	1.05	733	1 1 ,		
139	12.37	1314	0.97	674	1 2 ,		
123	14.05	1491	0.87	607	1 4 ,		
481	3.59	380	2.6	790	M 0 3 2 2 3 . 6 _ N _ _ _ 3 . 0 B _ _	94.1	182TC
343	5.03	534	2.12	797	5 . 0		
311	5.55	589	2	774	5 . 6		
274	6.3	666	1.85	737	6 . 3		
216	8	850	1.58	649	8 . 0		
190	9.09	967	1.45	589	9 . 0		
155	11.15	1185	1.27	470	1 1 ,		
139	12.37	1314	1.19	674	1 2 ,		
123	14.05	1488	1.09	607	1 4 ,		

NOTE

Other output speeds are available using 2 and 6 pole motors - Consult Application Engineering

SERIES M

SELECTION TABLES

GEARED MOTORS

3.0 HP

4 POLE
1750 rpm
nominal
input speed

N2 R/MIN	i	M2 lb.in	Fm	lb	Unit Designation	lb	Motor Size
Output Speed	Ratio	Output Torque	Service Factor	Overhung Load	Column Entry 1 Through 20 Spaces to be filled when entering order	Weight of base mount unit	
342	5.04	535	3.68	1034	M 0 4 2 2 5 . 0 _ _ N _ _ _ _ 3 . 0 B _ _	122.7	182TC
305	5.65	599	3.45	1049	5 . 6		
272	6.34	674	3.23	1067	6 . 3		
214	8.05	855	2.8	1103	8 . 0		
189	9.13	970	2.6	1122	9 . 0		
158	10.89	1157	2.31	1144	1 1 ,		
138	12.54	1332	1.77	1160	1 2 ,		
118	14.58	1549	1.58	1176	1 4 ,		
106	16.31	1731	1.47	1194	1 6 ,		
99	17.39	1844	1.4	1209	1 8 ,		
84	20.61	2191	1.21	1180	2 0 ,		
78	22	2331	1.15	1266	2 2 ,		
63	27.3	2902	0.96	1308	2 8 ,		
54	32.19	3404	0.84	1338	3 2 ,		
158	10.89	1160	3.43	1104	M 0 5 2 2 1 1 . _ _ N _ _ _ _ 3 . 0 B _ _	124.9	182TC
138	12.54	1334	2.82	1118	1 2 ,		
118	14.58	1553	2.56	1133	1 4 ,		
106	16.31	1734	2.3	1151	1 6 ,		
99	17.39	1848	2.15	1166	1 8 ,		
84	20.61	2188	1.82	1111	2 0 ,		
78	22	2335	1.71	1082	2 2 ,		
63	27.3	2897	1.37	954	2 8 ,		
54	32.19	3404	0.84	1288	3 2 ,		
128	13.48	1435	3.72	1618	M 0 6 2 2 1 2 . _ _ N _ _ _ _ 3 . 0 B _ _	136	182TC
111	15.52	1654	2.82	1618	1 4 ,		
96	18.05	1921	2.75	1618	1 6 ,		
85	20.2	2149	2.58	1618	1 8 ,		
80	21.53	2290	2.42	1618	2 0 ,		
68	25.51	2715	2.04	1618	2 2 ,		
63	27.24	2897	1.91	1618	2 8 ,		
51	33.8	3592	1.54	1618	3 2 ,		
43	39.86	4219	1.31	1574	3 6 ,		
40	43.64	4622	1.2	1618	4 5 ,		
32	53.49	5654	0.81	1618	5 0 ,		
106	16.26	1725	3.93	1900	M 0 7 2 2 1 6 . _ _ N _ _ _ _ 3 . 0 B _ _	151.4	182TC
96	17.94	1905	3.59	1861	1 8 ,		
84	20.54	2179	3.21	1799	2 0 ,		
74	23.23	2461	2.87	1730	2 2 ,		
64	26.93	2849	2.52	1656	2 8 ,		
54	32.12	3398	2.15	1638	3 2 ,		
49	35.17	3722	1.98	1559	3 6 ,		
41	42.21	4453	1.68	1667	4 5 ,		
36	48.56	5113	1.21	2156	5 0 ,		
32	53.96	5664	0.93	1924	5 6 ,		
52	32.97	3485	3.96	3947	M 0 8 2 2 3 2 . _ _ N _ _ _ _ 3 . 0 B _ _	224.1	182TC
48	36.21	3839	3.69	4066	3 6 ,		
39	44.38	4706	3.08	3933	4 5 ,		
36	48.46	5130	2.85	3863	5 0 ,		
31	55.8	5871	2.29	3991	5 6 ,		
29	60.33	6266	2.13	4496	M 0 8 3 2 5 6 . _ _ N _ _ _ _ 3 . 0 B _ _	224.1	182TC
26	66.02	6917	2	4496	6 3 ,		
35	49.07	5193	3.87	6677	M 0 9 2 1 5 0 . _ _ N _ _ _ _ 3 . 0 B _ _	321.1	182TC
31	55.18	5833	3.08	6654	5 6 ,		
28	61.13	6468	3.38	6654	6 3 ,		
25	68.74	7253	3.01	6632	7 1 ,		
29	59.85	6275	3.44	6646	M 0 9 3 1 5 6 . _ _ N _ _ _ _ 3 . 0 B _ _	332.2	182TC
26	66.49	6972	3.2	6634	6 3 ,		
23	74.26	7778	3.11	6634	7 1 ,		
21	82.51	8648	2.89	6621	8 0 ,		
18	93.92	9838	2.37	6596	9 0 ,		
17	103.68	10866	2.15	6584	1 0 0		
15	116.55	12223	2.07	6571	1 1 2		
13	128.66	13485	1.88	6549	1 2 5		
12	145.2	15126	1.45	6524	1 4 0		
11	160.29	16705	1.31	6497	1 6 0		
7.5	231.06	23834	0.98	5780	M 0 9 4 1 2 2 5 _ _ N _ _ _ _ 3 . 0 B _ _	382.9	182TC
6.7	258.09	26587	0.95	5609	2 5 0		
5.7	300.18	30914	0.82	5609	2 8 0		

NOTE

Other output speeds are available using 2 and 6 pole motors - Consult Application Engineering

SERIES M

SELECTION TABLES

GEARED MOTORS

3.0 HP	N2 R/MIN	i	M2 lb.in	Fm	lb	Unit Designation	lb	Motor Size	
	Output Speed	Ratio	Output Torque	Service Factor	Overhung Load	Column Entry 1 Through 20 Spaces to be filled when entering order	Weight of base mount unit		
4 POLE 1750 rpm nominal input speed	18	95.44	9990	3.34	11128	M 1 0 3 1 9 0 . . N _ _ _ _ 3 . 0 B - -	444.6	182TC	
	16	109.97	11508	2.9	11061	1 0 0			
	15	112.77	11795	3.31	11061	1 1 2			
	13	129.94	13586	2.87	10993	1 2 5			
	13	135.88	14139	2.6	10971	1 4 0			
	11	156.57	16288	2.26	10881	1 6 0			
	7.8	220.22	22577	1.73	9347	M 1 0 4 1 2 2 5 _ N _ _ _ _ 3 . 0 B - -	519.6	182TC	
	7.1	242.24	24832	1.57	9347	2 5 0			
	6.2	278.36	28527	1.37	9347	2 8 0			
	5.5	315.65	32308	1.21	9347	3 0 0			
	5	348.16	35662	1.1	9347	3 6 0			
	4.3	398.71	40826	0.96	9347	4 0 0			
	3.9	443.06	45298	0.86	9347	4 5 0			
	12	139.07	14386	3.97	15039	M 1 3 3 1 1 4 0 _ N _ _ _ _ 3 . 0 B - -	616.6	182TC	
	11	154.89	16000	3.57	15017	1 6 0			
	10	173.37	18015	3.12	14994	1 8 0			
	9.4	184.46	19180	2.93	14994	2 0 0			
	8.1	212.09	21993	2.6	14972	2 2 5			
	7.6	226.98	23227	2.42	14529	M 1 3 4 1 2 2 5 _ N _ _ _ _ 3 . 0 B - -	682.7	182TC	
	6.9	249.68	25546	2.2	14529	2 5 0			
	6	286.9	29344	1.92	14529	2 8 0			
	5.3	325.33	33229	1.69	14529	3 0 0			
	4.8	358.84	36676	1.53	14529	3 6 0			
	4.2	410.95	41982	1.34	14529	4 0 0			
	3.7	463.22	47292	1.19	14529	4 5 0			
	3.3	523.74	53436	1.05	14529	5 0 0			
	2.8	607.22	61900	0.91	14529	6 5 0			
	7	246.73	25283	3.71	18122	M 1 4 4 1 2 2 5 _ N _ _ _ _ 3 . 0 B - -	938.4	182TC	
	6.4	271.4	27805	3.37	18122	2 5 0			
	5.5	311.86	31935	2.94	18122	2 8 0			
	4.9	353.64	36160	2.59	18122	3 0 0			
	4.4	390.06	39907	2.35	18122	3 6 0			
	3.9	446.71	45675	2.05	18122	4 0 0			
	3.5	492.49	50312	1.89	18122	4 5 0			
	3.1	556.83	56841	1.68	18122	5 0 0			
	2.7	645.58	65834	1.45	18122	6 5 0			
	2.2	770.01	78416	1.22	18122	7 3 0			
	2.2	801.52	81386	1.16	18122	8 6 0			
	1.9	929.27	94278	1	18122	1 0 C			
	1.6	1108.37	112319	0.84	18122	1 1 C			
	5.0 HP 4 POLE 1750 rpm nominal input speed	481	3.59	632	1.32	744	M 0 2 2 2 3 . 6 _ N _ _ _ _ 5 . 0 B - -	108.1	184TC
		343	5.03	890	1.08	723	5 . 0		
		311	5.55	977	1.02	683	5 . 6		
		274	6.3	1109	0.95	620	6 . 3		
		216	8	1414	0.82	467	8 . 0		
481		3.59	634	1.56	744	M 0 3 2 2 3 . 6 _ N _ _ _ _ 5 . 0 B - -	108.1	184TC	
343		5.03	890	1.27	723	5 . 0			
311		5.55	982	1.2	683	5 . 6			
274		6.3	1110	1.11	620	6 . 3			
216		8	1417	0.95	467	8 . 0			
190		9.09	1613	0.87	364	9 . 0			
481		3.58	629	2.67	964	M 0 4 2 2 3 . 6 _ N _ _ _ _ 5 . 0 B - -	136.7	184TC	
342		5.04	893	2.21	987	5 . 0			
305		5.65	999	2.07	997	5 . 6			
272		6.34	1123	1.94	1010	6 . 3			
214		8.05	1426	1.68	1015	8 . 0			
189		9.13	1617	1.56	983	9 . 0			
158		10.89	1929	1.39	922	1 1 ,			
138		12.54	2220	1.06	1045	1 2 ,			
118		14.58	2583	0.95	1043	1 4 ,			
106		16.31	2885	0.88	1045	1 6 ,			
99		17.39	3074	0.84	1050	1 8 ,			

NOTE

Other output speeds are available using 2 and 6 pole motors - Consult Application Engineering

SERIES M

SELECTION TABLES

GEARED MOTORS

5.0 HP

4 POLE
1750 rpm
nominal
input speed

N2 R/MIN	i	M2 lb.in	Fm	lb	Unit Designation	lb	Motor Size
Output Speed	Ratio	Output Torque	Service Factor	Overhung Load	Column Entry 1 Through 20 Spaces to be filled when entering order	Weight of base mount unit	
342	5.04	894	3.78	950	M 0 5 2 2 5 . 0 _ N _ _ _ _ 5 . 0 B _ _	138.9	184TC
305	5.65	1006	3.62	961	5 . 6		
272	6.34	1124	3.25	973	6 . 3		
214	8.05	1434	2.78	968	8 . 0		
189	9.13	1621	2.46	939	9 . 0		
158	10.89	1933	2.06	884	1 1 ,		
138	12.54	2224	1.69	1007	1 2 ,		
118	14.58	2588	1.54	1005	1 4 ,		
106	16.31	2891	1.38	1007	1 6 ,		
99	17.39	3080	1.29	1011	1 8 ,		
84	20.61	3647	1.09	861	2 0 ,		
78	22	3892	1.02	789	2 2 ,		
63	27.3	4828	0.82	490	2 8 ,		
276	6.24	1107	3.78	1618	M 0 6 2 2 5 . 6 _ N _ _ _ _ 5 . 0 B _ _	150	184TC
247	6.99	1246	3.62	1618	6 . 3		
220	7.85	1390	3.25	1618	8 . 0		
173	9.97	1773	2.93	1618	9 . 0		
153	11.3	2006	2.62	1618	1 1 ,		
128	13.48	2391	2.23	1549	1 2 ,		
111	15.52	2757	1.69	1618	1 4 ,		
96	18.05	3202	1.65	1618	1 6 ,		
85	20.2	3582	1.55	1618	1 8 ,		
80	21.53	3817	1.45	1618	2 0 ,		
68	25.51	4526	1.22	1618	2 2 ,		
63	27.24	4828	1.15	1618	2 8 ,		
51	33.8	5987	0.93	1618	3 2 ,		
152	11.35	2011	3.07	1771	M 0 7 2 2 1 1 _ N _ _ _ _ 5 . 0 B _ _	165.4	184TC
138	12.48	2208	2.88	1740	1 2 ,		
120	14.34	2540	2.58	1683	1 4 ,		
106	16.26	2875	2.36	1622	1 6 ,		
96	17.94	3175	2.15	1552	1 8 ,		
84	20.54	3632	1.92	1439	2 0 ,		
74	23.23	4102	1.72	1317	2 2 ,		
64	26.93	4749	1.51	1183	2 8 ,		
54	32.12	5664	1.29	1150	3 2 ,		
49	35.17	6203	1.19	1008	3 6 ,		
41	42.21	7423	1.01	1203	4 5 ,		
94	18.26	3229	3.73	3483	M 0 8 2 2 1 8 _ N _ _ _ _ 5 . 0 B _ _	238.1	184TC
83	20.66	3647	3.54	3462	2 0 ,		
74	23.32	4122	3.2	3490	2 2 ,		
61	28.27	5021	2.7	3564	2 8 ,		
52	32.97	5809	2.38	3398	3 2 ,		
48	36.21	6399	2.21	3636	3 6 ,		
39	44.38	7843	1.85	3370	4 5 ,		
36	48.46	8550	1.71	3230	5 0 ,		
31	55.8	9785	1.37	3485	5 6 ,		
53	32.31	5746	3.36	6117	M 0 9 2 1 3 2 _ N _ _ _ _ 5 . 0 B _ _	335.1	184TC
48	35.67	6295	3.09	6354	3 6 ,		
43	40.25	7128	3.07	6572	4 0 ,		
39	44.44	7875	2.78	6594	4 5 ,		
35	49.07	8655	2.32	6553	5 0 ,		
31	55.18	9722	1.85	6603	5 6 ,		
28	61.13	10781	2.03	6590	6 3 ,		
25	68.74	12089	1.81	6561	7 1 ,		
29	59.85	10459	2.06	6586	M 0 9 3 1 5 6 _ N _ _ _ _ 5 . 0 B _ _	346.2	184TC
26	66.49	11620	1.92	6564	6 3 ,		
23	74.26	12963	1.86	6564	7 1 ,		
21	82.51	14413	1.73	6542	8 0 ,		
18	93.92	16397	1.42	6497	9 0 ,		
17	103.68	18111	1.29	6474	1 0 0		
15	116.55	20371	1.24	6452	1 1 2		
13	128.66	22476	1.13	6429	1 2 5		
12	145.2	25210	0.87	6384	1 4 0		
33	51.49	9060	3.78	9808	M 1 0 2 1 5 6 _ N _ _ _ _ 5 . 0 B _ _	438.8	184TC
30	57.75	10165	3.62	10177	6 3 ,		
28	62.05	10880	3.38	10408	7 1 ,		

NOTE
Other output speeds are available using 2 and 6 pole motors - Consult Application Engineering

SERIES M

SELECTION TABLES

GEARED MOTORS

5.0 HP

4 POLE
1750 rpm
nominal
input speed

N2 R/MIN	i	M2 lb.in	Fm	lb	Unit Designation	lb	Motor Size
Output Speed	Ratio	Output Torque	Service Factor	Overhung Load	Column Entry 1 Through 20 Spaces to be filled when entering order	Weight of base mount unit	
29	60.23	10517	3.17	10296	M 1 0 3 1 5 6 . . N _ _ _ _ 5 . 0 B - -	458.6	184TC
26	66.93	11686	2.86	10633	6 3 ,		
24	71.17	12422	3.01	10851	7 1 ,		
22	79.08	13801	2.8	10986	8 0 .		
18	95.44	16650	2	10839	9 0 .		
16	109.97	19181	1.74	10733	1 0 0		
15	112.77	19659	1.99	10733	1 1 2		
13	129.94	22644	1.72	10614	1 2 5		
13	135.88	23565	1.56	10591	1 4 0		
11	156.57	27148	1.36	10441	1 6 0		
7.8	220.22	37628	1.04	9347	M 1 0 4 1 2 2 5 _ N _ _ _ _ 5 . 0 B - -	533.6	184TC
7.1	242.24	41387	0.94	9347	2 5 0		
6.2	278.36	47545	0.82	9347	2 8 0		
19	90.75	15724	3.49	15014	M 1 3 3 1 9 0 . . N _ _ _ _ 5 . 0 B - -	630.6	184TC
17	101.07	17590	3.12	15009	1 0 0		
15	113.69	19683	2.86	14998	1 1 2		
14	126.62	21893	2.57	14968	1 2 5		
12	139.07	23976	2.38	14962	1 4 0		
11	154.89	26667	2.14	14933	1 6 0		
10	173.37	30026	1.87	14898	1 8 0		
9.4	184.46	31967	1.76	14894	2 0 0		
8.1	212.09	36655	1.56	14852	2 2 5		
7.6	226.98	38713	1.45	14529	M 1 3 4 1 2 2 5 _ N _ _ _ _ 5 . 0 B - -	696.7	184TC
6.9	249.68	42577	1.32	14529	2 5 0		
6	286.9	48906	1.15	14529	2 8 0		
5.3	325.33	55383	1.01	14529	3 0 0		
4.8	358.84	61127	0.92	14529	3 6 0		
4.2	410.95	69970	0.8	14529	4 0 0		
12	142.66	24502	3.65	20986	M 1 4 3 1 1 4 0 _ N _ _ _ _ 5 . 0 B - -	919.4	184TC
11	154.57	26624	3.36	20978	1 6 0		
9.3	185.56	32022	3.04	20941	1 8 0		
8.3	208.15	36104	2.7	20888	2 0 0		
8.1	211.96	36554	2.45	20936	2 2 5		
7	246.73	42139	2.23	18122	M 1 4 4 1 2 2 5 _ N _ _ _ _ 5 . 0 B - -	952.4	184TC
6.4	271.4	46342	2.02	18122	2 5 0		
5.5	311.86	53225	1.76	18122	2 8 0		
4.9	353.64	60267	1.56	18122	3 0 0		
4.4	390.06	66513	1.41	18122	3 6 0		
3.9	446.71	76125	1.23	18122	4 0 0		
3.5	492.49	83854	1.14	18122	4 5 0		
3.1	556.83	94735	1.01	18122	5 0 0		
2.7	645.58	109724	0.87	18122	6 5 0		

7.5 HP

4 POLE
1750 rpm
nominal
input speed

481	3.58	944	1.78	923	M 0 4 2 2 3 . 6 _ N _ _ _ _ 7 . 5 B - -	184.7	213TC
342	5.04	1339	1.47	930	5 . 0		
305	5.65	1498	1.38	932	5 . 6		
272	6.34	1685	1.29	937	6 . 3		
214	8.05	2139	1.12	905	8 . 0		
189	9.13	2425	1.04	809	9 . 0		
158	10.89	2894	0.92	644	1 1 ,		
481	3.58	952	2.71	889	M 0 5 2 2 3 . 6 _ N _ _ _ _ 7 . 5 B - -	186.9	213TC
342	5.04	1341	2.52	894	5 . 0		
305	5.65	1510	2.41	898	5 . 6		
272	6.34	1686	2.17	903	6 . 3		
214	8.05	2152	1.85	849	8 . 0		
189	9.13	2432	1.64	761	9 . 0		
158	10.89	2900	1.37	609	1 1 ,		
389	4.44	1180	2.71	1618	M 0 6 2 2 5 . 0 _ N _ _ _ _ 7 . 5 B - -	198	213TC
276	6.24	1661	2.52	1618	5 . 6		
247	6.99	1869	2.41	1618	6 . 3		
220	7.85	2086	2.17	1618	8 . 0		
173	9.97	2660	1.96	1618	9 . 0		
153	11.3	3010	1.75	1618	1 1 ,		
128	13.48	3587	1.49	1462	1 2 ,		

NOTE
Other output
speeds are
available
using 2 and 6
pole motors
- Consult
Application
Engineering

SERIES M

SELECTION TABLES

GEARED MOTORS

7.5 HP

4 POLE
1750 rpm
nominal
input speed

N2 R/MIN	i	M2 lb.in	Fm	lb	Unit Designation	lb	Motor Size
Output Speed	Ratio	Output Torque	Service Factor	Overhung Load	Column Entry 1 Through 20 Spaces to be filled when entering order	Weight of base mount unit	
469	3.68	969	2.78	1620	M 0 7 2 2 3 . 6 _ N _ _ _ _ 7 . 5 B _ _	213.4	213TC
339	5.09	1347	2.78	1674	5 . 0		
301	5.72	1516	2.78	1690	5 . 6		
274	6.29	1668	2.78	1712	6 . 3		
210	8.22	2190	2.49	1773	8 . 0		
185	9.34	2480	2.31	1800	9 . 0		
152	11.35	3017	2.04	1591	1 1 ,		
138	12.48	3312	1.92	1521	1 2 ,		
120	14.34	3811	1.72	1397	1 4 ,		
106	16.26	4313	1.57	1275	1 6 ,		
96	17.94	4762	1.43	1166	1 8 ,		
84	20.54	5449	1.28	990	2 0 ,		
74	23.23	6153	1.15	800	2 2 ,		
64	26.93	7123	1.01	591	2 8 ,		
54	32.12	8496	0.86	540	3 2 ,		
150	11.47	3032	3.65	3343	M 0 8 2 2 1 1 _ _ N _ _ _ _ 7 . 5 B _ _	286.1	213TC
133	12.92	3445	3.31	3327	1 2 ,		
115	15.04	3993	3.01	3308	1 4 ,		
103	16.69	4421	2.8	3150	1 6 ,		
94	18.26	4843	2.49	3103	1 8 ,		
83	20.66	5471	2.36	3013	2 0 ,		
74	23.32	6183	2.13	2961	2 2 ,		
61	28.27	7532	1.8	2982	2 8 ,		
52	32.97	8714	1.58	2712	3 2 ,		
48	36.21	9599	1.48	3099	3 6 ,		
39	44.38	11765	1.23	2666	4 5 ,		
36	48.46	12826	1.14	2438	5 0 ,		
31	55.8	14678	0.92	2854	5 6 ,		
66	26.04	6931	3.38	5544	M 0 9 2 1 2 5 _ _ N _ _ _ _ 7 . 5 B _ _	383.1	213TC
60	28.74	7648	3.07	5655	2 8 ,		
53	32.31	8619	2.24	5838	3 2 ,		
48	35.67	9442	2.06	6119	3 6 ,		
43	40.25	10692	2.04	6440	4 0 ,		
39	44.44	11813	1.85	6491	4 5 ,		
35	49.07	12983	1.55	6398	5 0 ,		
31	55.18	14583	1.23	6538	5 6 ,		
28	61.13	16171	1.35	6509	6 3 ,		
25	68.74	18134	1.21	6472	7 1 ,		
47	37.06	9802	3.67	8730	M 1 0 2 1 4 0 _ _ N _ _ _ _ 7 . 5 B _ _	486.8	213TC
40	42.7	11305	3.23	9121	4 5 ,		
36	47.93	12666	2.77	9417	5 0 ,		
33	51.49	13590	2.52	9619	5 6 ,		
30	57.75	15248	2.41	9972	6 3 ,		
28	62.05	16320	2.26	10184	7 1 ,		
29	60.23	15776	2.11	10071	M 1 0 3 1 5 6 _ _ N _ _ _ _ 7 . 5 B _ _	506.6	213TC
26	66.93	17529	1.9	10380	6 3 ,		
24	71.17	18633	2.01	10588	7 1 ,		
22	79.08	20702	1.87	10695	8 0 ,		
18	95.44	24976	1.34	10477	9 0 ,		
16	109.97	28771	1.16	10323	1 0 0		
15	112.77	29488	1.32	10323	1 1 2		
13	129.94	33966	1.15	10140	1 2 5		
13	135.88	35347	1.04	10115	1 4 0		
11	156.57	40722	0.9	9890	1 6 0		
30	56.93	14915	3.54	15006	M 1 3 3 1 5 6 _ _ N _ _ _ _ 7 . 5 B _ _	691.8	213TC
27	64.17	16776	3.15	15006	6 3 ,		
24	71.32	18539	3.03	14997	7 1 ,		
21	80.39	20978	2.68	14983	8 0 ,		
19	90.75	23586	2.33	14955	9 0 ,		
17	101.07	26385	2.08	14944	1 0 0		
15	113.69	29525	1.9	14918	1 1 2		
14	126.62	32840	1.71	14879	1 2 5		
12	139.07	35965	1.59	14866	1 4 0		
11	154.89	40000	1.43	14829	1 6 0		
10	173.37	45039	1.25	14778	1 8 0		
9.4	184.46	47951	1.17	14769	2 0 0		
8.1	212.09	54983	1.04	14702	2 2 5		

NOTE
Other output speeds are available using 2 and 6 pole motors - Consult Application Engineering

SERIES M

SELECTION TABLES

GEARED MOTORS

7.5 HP

4 POLE
1750 rpm
nominal
input speed

N2 R/MIN	i	M2 lb.in	Fm	lb	Unit Designation	lb	Motor Size
Output Speed	Ratio	Output Torque	Service Factor	Overhung Load	Column Entry 1 Through 20 Spaces to be filled when entering order	Weight of base mount unit	
7.6 6.9	226.98 249.68	58069 63865	0.97 0.88	14529 14529	M 1 3 4 1 2 2 5 _ N _ _ _ _ 7 . 5 B - - 2 5 0	744.7	213TC
17 14 13 12 11	102.23 124.89 135.31 142.66 154.57	26670 32303 35184 36753 39936	3.68 3.01 2.77 2.43 2.24	20967 20926 20908 20917 20898	M 1 4 3 1 1 0 0 _ N _ _ _ _ 7 . 5 B - - 1 1 2 1 2 5 1 4 0 1 6 0	985	213TC
9.3 8.3 8.1	185.56 208.15 211.96	48034 54156 54831	2.03 1.8 1.63	20842 20780 20831	1 8 0 2 0 0 2 2 5		
7 6.4 5.5 4.9 4.4 3.9	246.73 271.4 311.86 353.64 390.06 446.71	63209 69513 79838 90400 99769 114188	1.48 1.35 1.17 1.04 0.94 0.82	18122 18122 18122 18122 18122 18122	M 1 4 4 1 2 2 5 _ N _ _ _ _ 7 . 5 B - - 2 5 0 2 8 0 3 0 0 3 6 0 4 0 0	1000.4	213TC

10 HP

4 POLE
1750 rpm
nominal
input speed

481 342 305 272 214	3.58 5.04 5.65 6.34 8.05	1259 1786 1998 2247 2853	1.34 1.11 1.04 0.97 0.84	881 872 867 865 795	M 0 4 2 2 3 . 6 _ N _ _ _ _ 1 0 . B - - 5 . 0 5 . 6 6 . 3 8 . 0	199.7	215TC
481 342 305 272 214 189 158	3.58 5.04 5.65 6.34 8.05 9.13 10.89	1269 1788 2013 2248 2869 3243 3867	2.04 1.89 1.81 1.63 1.39 1.23 1.03	849 838 836 834 730 584 334	M 0 5 2 2 3 . 6 _ N _ _ _ _ 1 0 . B - - 5 . 0 5 . 6 6 . 3 8 . 0 9 . 0 1 1 . 1 1 .	201.9	215TC
389 276 247 220 173 153 128	4.44 6.24 6.99 7.85 9.97 11.3 13.48	1573 2214 2492 2781 3546 4013 4783	2.04 1.89 1.81 1.63 1.47 1.31 1.12	1618 1618 1618 1618 1618 1618 1375	M 0 6 2 2 5 . 0 _ N _ _ _ _ 1 0 . B - - 5 . 6 6 . 3 8 . 0 9 . 0 1 1 . 1 2 .	213	215TC
469 339 301 274 210 185 152 138 120 106 96 84 74	3.68 5.09 5.72 6.29 8.22 9.34 11.35 12.48 14.34 16.26 17.94 20.54 23.23	1292 1796 2021 2224 2920 3306 4023 4416 5081 5750 6350 7265 8205	2.09 2.09 2.09 2.09 1.86 1.73 1.53 1.44 1.29 1.18 1.08 0.96 0.86	1587 1569 1556 1550 1514 1484 1411 1301 1112 928 779 541 282	M 0 7 2 2 3 . 6 _ N _ _ _ _ 1 0 . B - - 5 . 0 5 . 6 6 . 3 8 . 0 9 . 0 1 1 . 1 2 . 1 4 . 1 6 . 1 8 . 2 0 . 2 2 .	228.4	215TC
268 207 184 150 133 115 103 94 83 74 61 52 48 39 36	6.44 8.33 9.35 11.47 12.92 15.04 16.69 18.26 20.66 23.32 28.27 32.97 36.21 44.38 48.46	2277 2952 3319 4043 4594 5325 5895 6458 7295 8245 10043 11618 12799 15686 17101	3.89 3.36 3.12 2.74 2.49 2.26 2.1 1.86 1.77 1.6 1.35 1.19 1.11 0.93 0.85	3152 3235 3210 3164 3102 3010 2822 2723 2564 2431 2400 2026 2562 1962 1647	M 0 8 2 2 6 . 3 _ N _ _ _ _ 1 0 . B - - 8 . 0 9 . 0 1 1 . 1 2 . 1 4 . 1 6 . 1 8 . 2 0 . 2 2 . 2 8 . 3 2 . 3 6 . 4 5 . 5 0 .	301.1	215TC

NOTE
Other output
speeds are
available
using 2 and 6
pole motors
- Consult
Application
Engineering

SERIES M

SELECTION TABLES

GEARED MOTORS

10 HP

4 POLE
1750 rpm
nominal
input speed

N2 R/MIN	i	M2 lb.in	Fm	lb	Unit Designation	lb	Motor Size
Output Speed	Ratio	Output Torque	Service Factor	Overhung Load	Column Entry 1 Through 20 Spaces to be filled when entering order	Weight of base mount unit	
104	16.59	5902	3.79	4899	M 0 9 2 1 1 6 . . . N 1 0 . B - -	398.1	215TC
94	18.43	6545	3.53	5095	1 8 ,		
84	20.59	7324	3.24	4980	2 0 ,		
75	22.87	8134	3.01	5174	2 2 ,		
66	26.04	9241	2.54	5340	2 5 ,		
60	28.74	10197	2.3	5399	2 8 ,		
53	32.31	11493	1.68	5560	3 2 ,		
48	35.67	12590	1.55	5884	3 6 ,		
43	40.25	14257	1.53	6309	4 0 ,		
39	44.44	15750	1.39	6388	4 5 ,		
35	49.07	17311	1.16	6244	5 0 ,		
31	55.18	19445	0.92	6474	5 6 ,		
28	61.13	21562	1.01	6429	6 3 ,		
25	68.74	24178	0.9	6384	7 1 ,		
66	26.03	9212	3.62	7624	M 1 0 2 1 2 5 . . . N 1 0 . B - -	501.8	215TC
58	29.99	10606	3.15	7841	2 8 ,		
56	30.76	10895	3.58	7925	3 2 ,		
49	35.44	12511	3.12	8473	3 6 ,		
47	37.06	13069	2.75	8596	4 0 ,		
40	42.7	15074	2.42	8967	4 5 ,		
36	47.93	16888	2.08	9240	5 0 ,		
33	51.49	18120	1.89	9431	5 6 ,		
30	57.75	20331	1.81	9767	6 3 ,		
28	62.05	21760	1.69	9959	7 1 ,		
29	60.23	21035	1.59	9846	M 1 0 3 1 5 6 . . . N 1 0 . B - -	521.6	215TC
26	66.93	23372	1.43	10127	6 3 ,		
24	71.17	24844	1.51	10326	7 1 ,		
22	79.08	27603	1.4	10405	8 0 ,		
18	95.44	33301	1	10116	9 0 ,		
16	109.97	38362	0.87	9913	1 0 0		
15	112.77	39318	0.99	9913	1 1 2		
13	129.94	45288	0.86	9666	1 2 5		
40	43.45	15176	3.77	14665	M 1 3 2 1 4 5 . . . N 1 0 . B - -	658.3	215TC
30	56.93	19887	2.66	14962	M 1 3 3 1 5 6 . . . N 1 0 . B - -	706.8	215TC
27	64.17	22368	2.37	14962	6 3 ,		
24	71.32	24719	2.27	14948	7 1 ,		
21	80.39	27971	2.01	14927	8 0 ,		
19	90.75	31449	1.74	14895	9 0 ,		
17	101.07	35180	1.56	14878	1 0 0		
15	113.69	39367	1.43	14839	1 1 2		
14	126.62	43787	1.28	14790	1 2 5		
12	139.07	47953	1.19	14769	1 4 0		
11	154.89	53334	1.07	14724	1 6 0		
10	173.37	60052	0.94	14657	1 8 0		
22	78.7	27278	3.57	20881	M 1 4 3 1 7 1 . . . N 1 0 . B - -	1000	215TC
20	86.76	30062	3.24	20873	8 0 ,		
18	94.35	32740	3	20930	9 0 ,		
17	102.23	35560	2.76	20913	1 0 0		
14	124.89	43071	2.26	20861	1 1 2		
13	135.31	46912	2.08	20834	1 2 5		
12	142.66	49004	1.82	20847	1 4 0		
11	154.57	53248	1.68	20819	1 6 0		
9.3	185.56	64045	1.52	20744	1 8 0		
8.3	208.15	72208	1.35	20673	2 0 0		
8.1	211.96	73109	1.22	20727	2 2 5		
7	246.73	84279	1.11	18122	M 1 4 4 1 2 2 5 . . . N 1 0 . B - -	1015.4	215TC
6.4	271.4	92684	1.01	18122	2 5 0		
5.5	311.86	106451	0.88	18122	2 8 0		

NOTE

Other output speeds are available using 2 and 6 pole motors - Consult Application Engineering

SERIES M

SELECTION TABLES

GEARED MOTORS

15 HP

4 POLE
1750 rpm
nominal
input speed

N2 R/MIN	i	M2 lb.in	Fm	lb	Unit Designation	lb	Motor Size
Output Speed	Ratio	Output Torque	Service Factor	Overhung Load	Column Entry 1 Through 20 Spaces to be filled when entering order	Weight of base mount unit	
479	3.68	1900	1.42	1519	M 0 7 2 2 3 . 6 _ N _ _ _ _ 1 5 . B - -	341.4	254TC
345	5.09	2641	1.42	1360	5 . 0		
308	5.72	2971	1.42	1289	5 . 6		
280	6.29	3270	1.42	1227	6 . 3		
214	8.22	4293	1.27	997	8 . 0		
188	9.34	4861	1.18	852	9 . 0		
479	3.68	1906	2.85	2840	M 0 8 2 2 3 . 6 _ N _ _ _ _ 1 5 . B - -	414.1	254TC
338	5.21	2714	2.85	3017	5 . 0		
304	5.79	3016	2.8	3046	5 . 6		
273	6.44	3348	2.64	3059	6 . 3		
211	8.33	4340	2.28	3090	8 . 0		
188	9.35	4880	2.12	2999	9 . 0		
153	11.47	5944	1.86	2807	1 1 ,		
136	12.92	6754	1.69	2652	1 2 ,		
117	15.04	7828	1.54	2414	1 4 ,		
105	16.69	8667	1.43	2167	1 6 ,		
96	18.26	9494	1.27	1964	1 8 ,		
85	20.66	10725	1.2	1666	2 0 ,		
75	23.32	12121	1.09	1371	2 2 ,		
62	28.27	14765	0.92	1236	2 8 ,		
53	32.97	17081	0.81	654	3 2 ,		
192	9.19	4804	3.78	4563	M 0 9 2 1 9 . 0 _ N _ _ _ _ 1 5 . B - -	511.1	254TC
171	10.27	5369	3.56	4653	1 0 ,		
150	11.71	6145	3.25	4743	1 1 ,		
138	12.74	6669	3.04	4833	1 2 ,		
121	14.53	7589	2.79	4923	1 4 ,		
106	16.59	8677	2.58	4577	1 6 ,		
95	18.43	9622	2.4	4833	1 8 ,		
85	20.59	10767	2.2	4554	2 0 ,		
77	22.87	11959	2.05	4808	2 2 ,		
68	26.04	13586	1.73	4931	2 5 ,		
61	28.74	14991	1.56	4888	2 8 ,		
54	32.31	16897	1.14	5003	3 2 ,		
49	35.67	18509	1.05	5415	3 6 ,		
44	40.25	20960	1.04	6047	4 0 ,		
40	44.44	23156	0.94	6182	4 5 ,		
107	16.43	8570	3.89	7007	M 1 0 2 1 1 6 . _ N _ _ _ _ 1 5 . B - -	614.8	254TC
96	18.25	9515	3.51	7061	1 8 ,		
91	19.41	10105	3.71	7117	2 0 ,		
82	21.57	11224	3.46	7114	2 2 ,		
68	26.03	13544	2.46	7354	2 5 ,		
59	29.99	15592	2.14	7452	2 8 ,		
57	30.76	16018	2.44	7548	3 2 ,		
50	35.44	18394	2.12	8215	3 6 ,		
47	37.06	19214	1.87	8330	4 0 ,		
41	42.7	22161	1.65	8661	4 5 ,		
37	47.93	24828	1.41	8888	5 0 ,		
34	51.49	26640	1.29	9054	5 6 ,		
30	57.75	29890	1.23	9357	6 3 ,		
28	62.05	31992	1.15	9509	7 1 ,		
29	60.23	30925	1.08	9396	M 1 0 3 1 5 6 . _ N _ _ _ _ 1 5 . B - -	634.6	254TC
26	66.93	34362	0.97	9621	6 3 ,		
25	71.17	36525	1.03	9801	7 1 ,		
22	79.08	40582	0.95	9824	8 0 ,		
62	28.35	14670	3.74	12989	M 1 3 2 1 2 8 . _ N _ _ _ _ 1 5 . B - -	771.3	254TC
55	31.89	16449	3.42	13380	3 2 ,		
50	35.52	18330	3.07	13818	3 6 ,		
45	39.01	20095	2.82	14021	4 0 ,		
41	43.45	22312	2.56	14349	4 5 ,		

NOTE

Other output speeds are available using 2 and 6 pole motors - Consult Application Engineering

SERIES M

SELECTION TABLES

GEARED MOTORS

15 HP	N2 R/MIN	i	M2 lb.in	Fm	lb	Unit Designation	lb	Motor Size	
	Output Speed	Ratio	Output Torque	Service Factor	Overhung Load	Column Entry 1 Through 20 Spaces to be filled when entering order	Weight of base mount unit		
4 POLE 1750 rpm nominal input speed	44	39.93	20543	2.27	14455	M 1 3 3 1 4 0 . _ _ N _ _ _ _ 1 5 . B - -	819.8	254TC	
	40	44.18	22614	2.33	14859	4 5 ,			
	35	50.02	25619	2.1	14927	5 0 ,			
	31	56.93	29237	1.81	14874	5 6 ,			
	27	64.17	32885	1.61	14874	6 3 ,			
	25	71.32	36341	1.55	14851	7 1 ,			
	22	80.39	41123	1.37	14814	8 0 ,			
	19	90.75	46235	1.19	14776	9 0 ,			
	17	101.07	51721	1.06	14747	1 0 0			
	15	113.69	57877	0.97	14680	1 1 2			
	14	126.62	64374	0.87	14612	1 2 5			
	41	42.71	22036	3.96	19235	M 1 4 2 1 4 5 . _ _ N _ _ _ _ 1 5 . B - -	1013.8	254TC	
	43	41.36	21157	3.79	19018	M 1 4 3 1 4 0 . _ _ N _ _ _ _ 1 5 . B - -	1113	254TC	
	37	48.21	24665	3.95	19850	4 5 ,			
	32	54.75	27979	3.48	20547	5 0 ,			
	30	59.46	30311	2.95	20512	5 6 ,			
	27	65.55	33462	2.72	20495	6 3 ,			
	22	78.7	40104	2.43	20751	7 1 ,			
	20	86.76	44196	2.2	20736	8 0 ,			
	19	94.35	48134	2.04	20834	9 0 ,			
	17	102.23	52280	1.88	20804	1 0 0			
	14	124.89	63322	1.54	20732	1 1 2			
	13	135.31	68968	1.41	20686	1 2 5			
	12	142.66	72044	1.24	20708	1 4 0			
	11	154.57	78284	1.14	20659	1 6 0			
	9.5	185.56	94157	1.03	20547	1 8 0			
	8.5	208.15	106158	0.92	20457	2 0 0			
	20 HP	479	3.68	2533	1.07	1452	M 0 7 2 2 3 . 6 _ _ N _ _ _ _ 2 0 . B - -	368.4	256TC
		345	5.09	3522	1.07	1150	5 . 0		
		308	5.72	3962	1.07	1022	5 . 6		
		280	6.29	4361	1.07	903	6 . 3		
		214	8.22	5724	0.95	480	8 . 0		
		188	9.34	6482	0.88	220	9 . 0		
		479	3.68	2542	2.14	2787	M 0 8 2 2 3 . 6 _ _ N _ _ _ _ 2 0 . B - -	441.1	256TC
		338	5.21	3618	2.14	2944	5 . 0		
304		5.79	4021	2.1	2967	5 . 6			
273		6.44	4464	1.98	2967	6 . 3			
211		8.33	5787	1.71	2944	8 . 0			
188		9.35	6506	1.59	2787	9 . 0			
153		11.47	7925	1.4	2450	1 1 ,			
136		12.92	9005	1.27	2202	1 2 ,			
117		15.04	10438	1.15	1818	1 4 ,			
105		16.69	11556	1.07	1512	1 6 ,			
96		18.26	12659	0.95	1204	1 8 ,			
85		20.66	14300	0.9	767	2 0 ,			
75		23.32	16162	0.82	311	2 2 ,			
477		3.69	2567	3.72	3831	M 0 9 2 1 3 . 6 _ _ N _ _ _ _ 2 0 . B - -	538.1	256TC	
310		5.69	3953	3.85	4226	5 . 6			
266		6.63	4623	3.56	4284	6 . 3			
238		7.4	5175	3.32	4342	7 . 1			
214		8.22	5733	3.04	4409	8 . 0			
192		9.19	6406	2.83	4457	9 . 0			
171		10.27	7159	2.67	4470	1 0 ,			
150		11.71	8194	2.44	4492	1 1 ,			
138		12.74	8892	2.28	4569	1 2 ,			
121		14.53	10118	2.09	4582	1 4 ,			
106		16.59	11570	1.94	4255	1 6 ,			
95		18.43	12830	1.8	4571	1 8 ,			
85		20.59	14357	1.65	4129	2 0 ,			
77		22.87	15945	1.54	4442	2 2 ,			
68		26.04	18115	1.29	4522	2 5 ,			
61		28.74	19989	1.17	4377	2 8 ,			
54	32.31	22529	0.86	4445	3 2 ,				

NOTE

Other output speeds are available using 2 and 6 pole motors - Consult Application Engineering

SERIES M

SELECTION TABLES

GEARED MOTORS

20 HP	N2 R/MIN	i	M2 lb.in	Fm	lb	Unit Designation	lb	Motor Size
	Output Speed	Ratio	Output Torque	Service Factor	Overhung Load	Column Entry 1 Through 20 Spaces to be filled when entering order	Weight of base mount unit	
4 POLE 1750 rpm nominal input speed	147	11.98	8358	3.77	6538	M 1 0 2 1 1 1 . . . N _ _ _ _ 2 0 . B - -	641.8	256TC
	141	12.51	8694	3.74	6586	1 2 ,		
	124	14.16	9837	3.45	6728	1 4 ,		
	107	16.43	11427	2.92	6883	1 6 ,		
	96	18.25	12687	2.63	6894	1 8 ,		
	91	19.41	13474	2.79	6935	2 0 ,		
	82	21.57	14965	2.6	6865	2 2 ,		
	68	26.03	18058	1.85	7083	2 5 ,		
	59	29.99	20790	1.6	7063	2 8 ,		
	57	30.76	21358	1.83	7172	3 2 ,		
	50	35.44	24525	1.59	7957	3 6 ,		
	47	37.06	25619	1.4	8064	4 0 ,		
	41	42.7	29549	1.23	8354	4 5 ,		
	37	47.93	33105	1.06	8535	5 0 ,		
	34	51.49	35520	0.96	8677	5 6 ,		
	30	57.75	39854	0.92	8946	6 3 ,		
	29	60.23	41234	0.81	8946	M 1 0 3 1 5 6 . . . N _ _ _ _ 2 0 . B - -	661.6	256TC
	78	22.55	15607	3.6	12267	M 1 3 2 1 2 2 . . . N _ _ _ _ 2 0 . B - -	798.3	256TC
	69	25.45	17613	3.12	12405	2 5 ,		
	62	28.35	19561	2.81	12762	2 8 ,		
	55	31.89	21932	2.56	13120	3 2 ,		
	50	35.52	24441	2.3	13552	3 6 ,		
	45	39.01	26793	2.12	13672	4 0 ,		
	41	43.45	29750	1.92	14032	4 5 ,		
	44	39.93	27391	1.71	14158	M 1 3 3 1 4 0 . . . N _ _ _ _ 2 0 . B - -	846.8	256TC
	40	44.18	30152	1.75	14518	4 5 ,		
	35	50.02	34158	1.58	14799	5 0 ,		
	31	56.93	38983	1.36	14787	5 6 ,		
	27	64.17	43847	1.21	14787	6 3 ,		
	25	71.32	48455	1.16	14754	7 1 ,		
	22	80.39	54831	1.03	14702	8 0 ,		
	19	90.75	61647	0.89	14657	9 0 ,		
	51	34.51	23843	3.97	17464	M 1 4 2 1 3 2 . . . N _ _ _ _ 2 0 . B - -	1040.8	256TC
	47	37.39	25772	3.71	18030	3 6 ,		
	45	39.42	27023	3.2	18636	4 0 ,		
	41	42.71	29382	2.97	19054	4 5 ,		
	43	41.36	28209	2.85	18741	M 1 4 3 1 4 0 . . . N _ _ _ _ 2 0 . B - -	1140	256TC
	37	48.21	32887	2.96	19430	4 5 ,		
	32	54.75	37306	2.61	20122	5 0 ,		
	30	59.46	40415	2.21	20263	5 6 ,		
	27	65.55	44616	2.04	20249	6 3 ,		
	22	78.7	53472	1.82	20620	7 1 ,		
	20	86.76	58928	1.65	20599	8 0 ,		
	19	94.35	64179	1.53	20739	9 0 ,		
	17	102.23	69706	1.41	20696	1 0 0		
14	124.89	84429	1.15	20603	1 1 2			
13	135.31	91958	1.06	20538	1 2 5			
12	142.66	96059	0.93	20569	1 4 0			
25 HP 4 POLE 1750 rpm nominal input speed NOTE Other output speeds are available using 2 and 6 pole motors - Consult Application Engineering	533	3.3	2876	3.32	3667	M 0 9 2 1 3 . 2 _ . . . N _ _ _ _ 2 5 . B - -	687.4	284TC
	477	3.69	3209	2.98	3796	3 . 6		
	431	4.09	3559	3.88	3937	4 . 0		
	384	4.58	3997	3.61	4059	4 . 5		
	347	5.07	4416	3.31	4126	5 . 0		
	310	5.69	4941	3.08	4181	5 . 6		
	266	6.63	5779	2.85	4229	6 . 3		
	238	7.4	6469	2.65	4277	7 . 1		
	214	8.22	7166	2.43	4345	8 . 0		
	192	9.19	8007	2.27	4351	9 . 0		
	171	10.27	8948	2.14	4287	1 0 ,		
	150	11.71	10242	1.95	4242	1 1 ,		
	138	12.74	11115	1.82	4306	1 2 ,		
	121	14.53	12648	1.67	4242	1 4 ,		
	106	16.59	14462	1.55	3933	1 6 ,		
	95	18.43	16037	1.44	4308	1 8 ,		
	85	20.59	17946	1.32	3703	2 0 ,		
	77	22.87	19932	1.23	4075	2 2 ,		
68	26.04	22644	1.04	4113	2 5 ,			
61	28.74	24986	0.94	3866	2 8 ,			

SERIES M

SELECTION TABLES

GEARED MOTORS

25 HP	N2 R/MIN	i	M2 lb.in	Fm	lb	Unit Designation	lb	Motor Size
	Output Speed	Ratio	Output Torque	Service Factor	Overhung Load	Column Entry 1 Through 20 Spaces to be filled when entering order	Weight of base mount unit	
							M 1 0 2 1 9 . 0 _ N _ _ _ _ 2 5 . B - -	
	205	8.58	7442	3.84	6121		791	284TC
	166	10.59	9211	3.33	6313	1 0 ,		
	147	11.98	10448	3.02	6445	1 1 ,		
	141	12.51	10868	2.99	6496	1 2 ,		
	124	14.16	12296	2.76	6622	1 4 ,		
	107	16.43	14284	2.34	6759	1 6 ,		
	96	18.25	15859	2.1	6727	1 8 ,		
	91	19.41	16843	2.23	6753	2 0 ,		
	82	21.57	18707	2.08	6616	2 2 ,		
	68	26.03	22573	1.48	6813	2 5 ,		
	59	29.99	25988	1.28	6674	2 8 ,		
	57	30.76	26698	1.46	6795	3 2 ,		
	50	35.44	30657	1.27	7699	3 6 ,		
	47	37.06	32023	1.12	7797	4 0 ,		
	41	42.7	36936	0.99	8047	4 5 ,		
	37	47.93	41381	0.85	8182	5 0 ,		
	110	15.97	13858	3.96	11505	M 1 3 2 1 1 6 _ _ N _ _ _ _ 2 5 . B - -	912.3	284TC
	98	18	15625	3.51	11652	1 8 ,		
	88	20	17305	3.25	11954	2 0 ,		
	78	22.55	19509	2.88	12079	2 2 ,		
	69	25.45	22017	2.49	12172	2 5 ,		
	62	28.35	24451	2.24	12535	2 8 ,		
	55	31.89	27415	2.05	12860	3 2 ,		
	50	35.52	30551	1.84	13287	3 6 ,		
	45	39.01	33491	1.69	13323	4 0 ,		
	41	43.45	37187	1.54	13716	4 5 ,		
	44	39.93	34239	1.36	13861	M 1 3 3 1 4 0 _ _ N _ _ _ _ 2 5 . B - -	960.8	284TC
	40	44.18	37690	1.4	14176	4 5 ,		
	35	50.02	42698	1.26	14672	5 0 ,		
	31	56.93	48729	1.08	14700	5 6 ,		
	27	64.17	54809	0.97	14700	6 3 ,		
	25	71.32	60569	0.93	14657	7 1 ,		
	68	26.07	22499	3.92	16441	M 1 4 2 1 2 5 _ _ N _ _ _ _ 2 5 . B - -	1154.8	284TC
	62	28.25	24377	3.62	16609	2 8 ,		
	51	34.51	29804	3.18	17172	3 2 ,		
	47	37.39	32215	2.97	17773	3 6 ,		
	45	39.42	33779	2.56	18470	4 0 ,		
	41	42.71	36727	2.37	18872	4 5 ,		
	43	41.36	35261	2.28	18464	M 1 4 3 1 4 0 _ _ N _ _ _ _ 2 5 . B - -	1254	284TC
	37	48.21	41109	2.37	19011	4 5 ,		
	32	54.75	46632	2.09	19698	5 0 ,		
	30	59.46	50519	1.77	20015	5 6 ,		
	27	65.55	55770	1.63	20003	6 3 ,		
	22	78.7	66840	1.46	20489	7 1 ,		
	20	86.76	73660	1.32	20463	8 0 ,		
	19	94.35	80224	1.22	20643	9 0 ,		
	17	102.23	87133	1.13	20588	1 0 0		
	14	124.89	105537	0.92	20474	1 1 2		
	13	135.31	114948	0.85	20390	1 2 5		
	864	2.04	2136	3.89	3134	M 0 9 2 1 1 . 8 _ _ N _ _ _ _ 3 0 . B - -	681.4	286TC
	771	2.28	2393	3.77	3259	2 . 2		
	687	2.56	2677	3.57	3362	2 . 5		
	593	2.97	3096	3.92	3542	2 . 8		
	533	3.3	3451	2.77	3635	3 . 2		
	477	3.69	3851	2.48	3760	3 . 6		
	431	4.09	4271	3.23	3905	4 . 0		
	384	4.58	4796	3.01	4020	4 . 5		
	347	5.07	5299	2.76	4088	5 . 0		
	310	5.69	5930	2.57	4136	5 . 6		
	266	6.63	6935	2.37	4174	6 . 3		
	238	7.4	7762	2.21	4213	7 . 1		
	214	8.22	8599	2.03	4280	8 . 0		
	192	9.19	9609	1.89	4245	9 . 0		
	171	10.27	10738	1.78	4104	1 0 ,		
	150	11.71	12291	1.63	3991	1 1 ,		
	138	12.74	13338	1.52	4043	1 2 ,		
	121	14.53	15178	1.39	3901	1 4 ,		
	106	16.59	17355	1.29	3611	1 6 ,		
	95	18.43	19245	1.2	4046	1 8 ,		
	85	20.59	21535	1.1	3278	2 0 ,		
	77	22.87	23918	1.03	3709	2 2 ,		

30 HP

4 POLE
1750 rpm
nominal
input speed

NOTE

Other output speeds are available using 2 and 6 pole motors - Consult Application Engineering

SERIES M

SELECTION TABLES

GEARED MOTORS

30 HP

4 POLE
1750 rpm
nominal
input speed

N2 R/MIN	i	M2 lb.in	Fm	lb	Unit Designation	lb	Motor Size
Output Speed	Ratio	Output Torque	Service Factor	Overhung Load	Column Entry 1 Through 20 Spaces to be filled when entering order	Weight of base mount unit	
543	3.24	3399	3.75	4926	M 1 0 2 1 3 . 2 _ N _ _ _ _ 3 0 . B - -	785	286TC
503	3.5	3661	3.53	5051	3 . 6		
262	6.72	7027	3.74	5893	6 . 3		
242	7.26	7574	3.53	5950	7 . 1		
222	7.95	8275	3.36	6008	8 . 0		
205	8.58	8931	3.2	6056	9 . 0		
166	10.59	11054	2.78	6233	1 0 ,		
147	11.98	12538	2.51	6352	1 1 ,		
141	12.51	13042	2.49	6406	1 2 ,		
124	14.16	14756	2.3	6516	1 4 ,		
107	16.43	17141	1.95	6634	1 6 ,		
96	18.25	19031	1.75	6559	1 8 ,		
91	19.41	20211	1.86	6571	2 0 ,		
82	21.57	22448	1.73	6367	2 2 ,		
68	26.03	27088	1.23	6543	2 5 ,		
59	29.99	31185	1.07	6285	2 8 ,		
57	30.76	32037	1.22	6418	3 2 ,		
50	35.44	36788	1.06	7441	3 6 ,		
47	37.06	38428	0.94	7531	4 0 ,		
125	14.03	14603	3.81	11303	M 1 3 2 1 1 4 _ _ N _ _ _ _ 3 0 . B - -	906.3	286TC
110	15.97	16629	3.3	11366	1 6 ,		
98	18	18750	2.93	11485	1 8 ,		
88	20	20766	2.71	11799	2 0 ,		
78	22.55	23411	2.4	11892	2 2 ,		
69	25.45	26420	2.08	11940	2 5 ,		
62	28.35	29341	1.87	12308	2 8 ,		
55	31.89	32898	1.71	12599	3 2 ,		
50	35.52	36661	1.53	13021	3 6 ,		
45	39.01	40190	1.41	12974	4 0 ,		
41	43.45	44625	1.28	13400	4 5 ,		
44	39.93	41086	1.14	13564	M 1 3 3 1 4 0 _ _ N _ _ _ _ 3 0 . B - -	954.8	286TC
40	44.18	45228	1.16	13834	4 5 ,		
35	50.02	51238	1.05	14545	5 0 ,		
31	56.93	58474	0.9	14612	5 6 ,		
27	64.17	65771	0.8	14612	6 3 ,		
73	23.97	24897	3.84	16017	M 1 4 2 1 2 2 _ _ N _ _ _ _ 3 0 . B - -	1148.8	286TC
68	26.07	26999	3.27	16274	2 5 ,		
62	28.25	29252	3.02	16418	2 8 ,		
51	34.51	35765	2.65	16879	3 2 ,		
47	37.39	38659	2.47	17515	3 6 ,		
45	39.42	40535	2.14	18305	4 0 ,		
41	42.71	44073	1.98	18691	4 5 ,		
43	41.36	42314	1.9	18186	M 1 4 3 1 4 0 _ _ N _ _ _ _ 3 0 . B - -	1248	286TC
37	48.21	49330	1.97	18591	4 5 ,		
32	54.75	55959	1.74	19273	5 0 ,		
30	59.46	60623	1.47	19766	5 6 ,		
27	65.55	66924	1.36	19756	6 3 ,		
22	78.7	80208	1.21	20359	7 1 ,		
20	86.76	88392	1.1	20326	8 0 ,		
19	94.35	96269	1.02	20547	9 0 ,		
17	102.23	104560	0.94	20480	1 0 0		

40 HP

4 POLE
1750 rpm
nominal
input speed

1190	1.48	2066	3.18	2813	M 0 9 2 1 1 . 4 _ N _ _ _ _ 4 0 . B - -	792.4	324TC
864	2.04	2849	2.92	3095	1 . 8		
771	2.28	3191	2.83	3214	2 . 2		
687	2.56	3570	2.68	3311	2 . 5		
593	2.97	4128	2.94	3490	2 . 8		
533	3.3	4602	2.08	3571	3 . 2		
477	3.69	5135	1.86	3690	3 . 6		
431	4.09	5695	2.42	3840	4 . 0		
384	4.58	6395	2.26	3943	4 . 5		
347	5.07	7065	2.07	4011	5 . 0		
310	5.69	7907	1.93	4046	5 . 6		
266	6.63	9247	1.78	4065	6 . 3		
238	7.4	10350	1.66	4085	7 . 1		
214	8.22	11466	1.52	4152	8 . 0		
192	9.19	12812	1.42	4033	9 . 0		
171	10.27	14318	1.34	3738	1 0 ,		
150	11.71	16388	1.22	3490	1 1 ,		
138	12.74	17784	1.14	3516	1 2 ,		
121	14.53	20237	1.05	3220	1 4 ,		
106	16.59	23140	0.97	2967	1 6 ,		
85	20.59	28714	0.83	2427	2 0 ,		

NOTE

Other output speeds are available using 2 and 6 pole motors - Consult Application Engineering

SERIES M

SELECTION TABLES

GEARED MOTORS

40 HP

4 POLE
1750 rpm
nominal
input speed

N2 R/MIN	i	M2 lb.in	Fm	lb	Unit Designation	lb	Motor Size
Output Speed	Ratio	Output Torque	Service Factor	Overhung Load	Column Entry 1 Through 20 Spaces to be filled when entering order	Weight of base mount unit	
1220	1.44	2004	3.18	3802	M 1 0 2 1 1 . 4 _ N _ _ _ _ 4 0 . B _ _	896	324TC
874	2.01	2808	3.18	4219	1 . 8		
803	2.19	3058	3.18	4332	2 . 2		
707	2.49	3475	3.18	4496	2 . 5		
588	2.99	4143	3.18	4788	2 . 8		
543	3.24	4532	2.81	4868	3 . 2		
503	3.5	4882	2.65	4987	3 . 6		
421	4.18	5811	3.18	5302	4 . 0		
387	4.55	6340	3.18	5443	4 . 5		
356	4.94	6868	3.18	5584	5 . 0		
328	5.37	7480	3.18	5674	5 . 6		
262	6.72	9370	2.81	5790	6 . 3		
242	7.26	10098	2.65	5841	7 . 1		
222	7.95	11034	2.52	5893	8 . 0		
205	8.58	11908	2.4	5928	9 . 0		
166	10.59	14739	2.08	6072	1 0 ,		
147	11.98	16717	1.88	6166	1 1 ,		
141	12.51	17389	1.87	6227	1 2 ,		
124	14.16	19674	1.72	6304	1 4 ,		
107	16.43	22855	1.46	6385	1 6 ,		
96	18.25	25375	1.31	6224	1 8 ,		
91	19.41	26949	1.39	6208	2 0 ,		
82	21.57	29931	1.3	5870	2 2 ,		
68	26.03	36117	0.92	6002	2 5 ,		
59	29.99	41580	0.8	5507	2 8 ,		
57	30.76	42716	0.91	5664	3 2 ,		
606	2.9	4042	3.81	8344	M 1 3 2 1 2 . 8 _ N _ _ _ _ 4 0 . B _ _	1030.5	324TC
552	3.19	4436	3.81	8569	3 . 2		
484	3.64	5040	3.81	8909	3 . 6		
437	4.03	5621	3.81	9172	4 . 0		
398	4.42	6179	3.81	9406	4 . 5		
349	5.04	7015	3.81	9775	5 . 0		
318	5.54	7712	3.81	9964	5 . 6		
283	6.21	8664	3.81	10095	6 . 3		
256	6.88	9594	3.81	10216	7 . 1		
226	7.78	10825	3.81	10354	8 . 0		
204	8.62	11986	3.81	10462	9 . 0		
178	9.89	13798	3.81	10637	1 0 ,		
157	11.2	15623	3.36	10792	1 1 ,		
142	12.39	17179	3.22	10941	1 2 ,		
125	14.03	19470	2.86	11076	1 4 ,		
110	15.97	22173	2.47	11088	1 6 ,		
98	18	25000	2.19	11152	1 8 ,		
88	20	27688	2.03	11490	2 0 ,		
78	22.55	31214	1.8	11517	2 2 ,		
69	25.45	35227	1.56	11474	2 5 ,		
62	28.35	39122	1.4	11855	2 8 ,		
55	31.89	43865	1.28	12079	3 2 ,		
50	35.52	48882	1.15	12490	3 6 ,		
45	39.01	53586	1.06	12275	4 0 ,		
41	43.45	59500	0.96	12768	4 5 ,		
44	39.93	54782	0.85	12971	M 1 3 3 1 4 0 _ N _ _ _ _ 4 0 . B _ _	1079	324TC
40	44.18	60304	0.87	13151	4 5 ,		
107	16.43	22822	3.64	15193	M 1 4 2 1 1 6 _ N _ _ _ _ 4 0 . B _ _	1275.2	324TC
97	18.11	25184	3.41	15425	1 8 ,		
81	21.75	30048	3.12	15601	2 0 ,		
73	23.97	33196	2.88	15687	2 2 ,		
68	26.07	35998	2.45	15940	2 5 ,		
62	28.25	39003	2.26	16038	2 8 ,		
51	34.51	47686	1.99	16295	3 2 ,		
47	37.39	51545	1.85	17000	3 6 ,		
45	39.42	54047	1.6	17974	4 0 ,		
41	42.71	58764	1.48	18328	4 5 ,		
43	41.36	56418	1.42	17632	M 1 4 3 1 4 0 _ N _ _ _ _ 4 0 . B _ _	1374.4	324TC
37	48.21	65774	1.48	17752	4 5 ,		
32	54.75	74612	1.3	18424	5 0 ,		
30	59.46	80830	1.11	19268	5 6 ,		
27	65.55	89232	1.02	19264	6 3 ,		
22	78.7	106944	0.91	20097	7 1 ,		
20	86.76	117857	0.83	20052	8 0 ,		

NOTE

Other output speeds are available using 2 and 6 pole motors - Consult Application Engineering

SERIES M

SELECTION TABLES

GEARED MOTORS

50 HP

4 POLE
1750 rpm
nominal
input speed

N2 R/MIN	i	M2 lb.in	Fm	lb	Unit Designation	lb	Motor Size
Output Speed	Ratio	Output Torque	Service Factor	Overhung Load	Column Entry 1 Through 20 Spaces to be filled when entering order	Weight of base mount unit	
1190	1.48	2582	2.55	2787	M 0 9 2 1 1 . 4 _ N _ _ _ _ 5 0 . B - -	945.4	326TC
864	2.04	3561	2.34	3057	1 . 8		
771	2.28	3989	2.26	3169	2 . 2		
687	2.56	4463	2.14	3259	2 . 5		
593	2.97	5161	2.35	3439	2 . 8		
533	3.3	5752	1.66	3506	3 . 2		
477	3.69	6419	1.49	3619	3 . 6		
431	4.09	7119	1.94	3776	4 . 0		
384	4.58	7994	1.8	3866	4 . 5		
347	5.07	8832	1.65	3934	5 . 0		
310	5.69	9883	1.54	3956	5 . 6		
266	6.63	11558	1.42	3956	6 . 3		
238	7.4	12938	1.33	3956	7 . 1		
214	8.22	14332	1.22	4023	8 . 0		
192	9.19	16015	1.13	3821	9 . 0		
171	10.27	17897	1.07	3371	1 0 ,		
150	11.71	20485	0.98	2989	1 1 ,		
138	12.74	22230	0.91	2989	1 2 ,		
121	14.53	25297	0.84	2539	1 4 ,		
1220	1.44	2506	2.55	3776	M 1 0 2 1 1 . 4 _ N _ _ _ _ 5 0 . B - -	1049	326TC
874	2.01	3510	2.55	4181	1 . 8		
803	2.19	3823	2.55	4293	2 . 2		
707	2.49	4344	2.55	4451	2 . 5		
588	2.99	5179	2.55	4743	2 . 8		
543	3.24	5665	2.25	4810	3 . 2		
503	3.5	6102	2.12	4923	3 . 6		
421	4.18	7264	2.55	5238	4 . 0		
387	4.55	7925	2.55	5372	4 . 5		
356	4.94	8585	2.55	5507	5 . 0		
328	5.37	9350	2.55	5597	5 . 6		
262	6.72	11713	2.24	5687	6 . 3		
242	7.26	12623	2.12	5732	7 . 1		
222	7.95	13792	2.01	5777	8 . 0		
205	8.58	14885	1.92	5799	9 . 0		
166	10.59	18423	1.67	5912	1 0 ,		
147	11.98	20896	1.51	5979	1 1 ,		
141	12.51	21736	1.49	6047	1 2 ,		
124	14.16	24593	1.38	6092	1 4 ,		
107	16.43	28568	1.17	6137	1 6 ,		
96	18.25	31718	1.05	5889	1 8 ,		
91	19.41	33686	1.11	5844	2 0 ,		
82	21.57	37414	1.04	5372	2 2 ,		
606	2.9	5052	3.05	8309	M 1 3 2 1 2 . 8 _ N _ _ _ _ 5 0 . B - -	1183.5	326TC
552	3.19	5546	3.05	8534	3 . 2		
484	3.64	6301	3.05	8866	3 . 6		
437	4.03	7027	3.05	9127	4 . 0		
398	4.42	7724	3.05	9356	4 . 5		
349	5.04	8769	3.05	9719	5 . 0		
318	5.54	9640	3.05	9903	5 . 6		
283	6.21	10831	3.05	10023	6 . 3		
256	6.88	11992	3.05	10140	7 . 1		
226	7.78	13531	3.05	10269	8 . 0		
204	8.62	14983	3.05	10367	9 . 0		
178	9.89	17248	3.05	10513	1 0 ,		
157	11.2	19529	2.69	10630	1 1 ,		
142	12.39	21474	2.58	10759	1 2 ,		
125	14.03	24338	2.29	10848	1 4 ,		
110	15.97	27716	1.98	10810	1 6 ,		
98	18	31250	1.76	10818	1 8 ,		
88	20	34611	1.62	11181	2 0 ,		
78	22.55	39018	1.44	11143	2 2 ,		
69	25.45	44034	1.25	11009	2 5 ,		
62	28.35	48903	1.12	11401	2 8 ,		
55	31.89	54831	1.03	11558	3 2 ,		
50	35.52	61102	0.92	11959	3 6 ,		
45	39.01	66983	0.85	11577	4 0 ,		

NOTE
Other output
speeds are
available
using 2 and 6
pole motors
- Consult
Application
Engineering

SERIES M

SELECTION TABLES

GEARED MOTORS

50 HP

4 POLE
1750 rpm
nominal
input speed

60 HP

4 POLE
1750 rpm
nominal
input speed

	N2 R/MIN	i	M2 lb.in	Fm	lb	Unit Designation	lb	Motor Size
	Output Speed	Ratio	Output Torque	Service Factor	Overhung Load	Column Entry 1 Through 20 Spaces to be filled when entering order	Weight of base mount unit	
	154	11.43	19825	3.86	14219	M 1 4 2 1 1 1 . . . N _ _ _ _ 5 0 . B - -	1428.2	326TC
	132	13.32	22923	3.94	14550	1 2 ,		
	116	15.13	26250	3.51	14845	1 4 ,		
	107	16.43	28528	2.91	15040	1 6 ,		
	97	18.11	31480	2.72	15256	1 8 ,		
	81	21.75	37560	2.5	15328	2 0 ,		
	73	23.97	41495	2.3	15358	2 2 ,		
	68	26.07	44998	1.96	15606	2 5 ,		
	62	28.25	48754	1.81	15658	2 8 ,		
	51	34.51	59608	1.59	15711	3 2 ,		
	47	37.39	64431	1.48	16485	3 6 ,		
	45	39.42	67559	1.28	17643	4 0 ,		
	41	42.71	73455	1.19	17965	4 5 ,		
	43	41.36	70523	1.14	17077	M 1 4 3 1 4 0 . . . N _ _ _ _ 5 0 . B - -	1527.4	326TC
	37	48.21	82218	1.18	16913	4 5 ,		
	32	54.75	93265	1.04	17574	5 0 ,		
	30	59.46	101038	0.88	18771	5 6 ,		
	27	65.55	111540	0.82	18771	6 3 ,		
	606	2.9	6063	2.54	8275	M 1 3 2 1 2 . 8 _ . . . N _ _ _ _ 6 0 . B - -	1183.5	364TC
	552	3.19	6655	2.54	8500	3 . 2		
	484	3.64	7561	2.54	8824	3 . 6		
	437	4.03	8432	2.54	9082	4 . 0		
	398	4.42	9268	2.54	9305	4 . 5		
	349	5.04	10523	2.54	9664	5 . 0		
	318	5.54	11568	2.54	9842	5 . 6		
	283	6.21	12997	2.54	9952	6 . 3		
	256	6.88	14391	2.54	10063	7 . 1		
	226	7.78	16237	2.54	10185	8 . 0		
	204	8.62	17980	2.54	10272	9 . 0		
	178	9.89	20698	2.54	10388	1 0 ,		
	157	11.2	23435	2.24	10469	1 1 ,		
	142	12.39	25768	2.15	10576	1 2 ,		
	125	14.03	29206	1.91	10621	1 4 ,		
	110	15.97	33259	1.65	10531	1 6 ,		
	98	18	37500	1.46	10484	1 8 ,		
	88	20	41533	1.35	10872	2 0 ,		
	78	22.55	46822	1.2	10768	2 2 ,		
	69	25.45	52840	1.04	10544	2 5 ,		
	62	28.35	58683	0.94	10948	2 8 ,		
	55	31.89	65797	0.85	11037	3 2 ,		
	610	2.89	6013	3.71	10694	M 1 4 2 1 2 . 8 _ . . . N _ _ _ _ 6 0 . B - -	1428.2	364TC
	542	3.25	6777	3.71	11052	3 . 2		
	460	3.82	7946	3.71	11590	3 . 6		
	437	4.03	8400	3.71	11770	4 . 0		
	388	4.54	9473	3.71	12174	4 . 5		
	330	5.33	11120	3.71	12745	5 . 0		
	293	6	12504	3.71	13046	5 . 6		
	269	6.55	13673	3.71	13180	6 . 3		
	242	7.27	15201	3.71	13336	7 . 1		
	203	8.67	18064	3.71	13591	8 . 0		
	183	9.62	20069	3.71	13735	9 . 0		
	175	10.06	20916	3.53	13846	1 0 ,		
	154	11.43	23790	3.21	14114	1 1 ,		
	132	13.32	27508	3.28	14423	1 2 ,		
	116	15.13	31500	2.92	14699	1 4 ,		
	107	16.43	34234	2.43	14887	1 6 ,		
	97	18.11	37776	2.27	15086	1 8 ,		
	81	21.75	45072	2.08	15054	2 0 ,		
	73	23.97	49795	1.92	15029	2 2 ,		
	68	26.07	53998	1.63	15273	2 5 ,		
	62	28.25	58505	1.51	15278	2 8 ,		
	51	34.51	71530	1.32	15127	3 2 ,		
	47	37.39	77318	1.24	15969	3 6 ,		
	45	39.42	81071	1.07	17312	4 0 ,		
	41	42.71	88146	0.99	17602	4 5 ,		
	43	41.36	84628	0.95	16523	M 1 4 3 1 4 0 . . . N _ _ _ _ 6 0 . B - -	1527.4	364TC
	37	48.21	98661	0.99	16073	4 5 ,		
	32	54.75	111918	0.87	16725	5 0 ,		

NOTE
Other output
speeds are
available
using 2 and 6
pole motors
- Consult
Application
Engineering

SERIES M

SELECTION TABLES

GEARED MOTORS

75 HP

4 POLE
1750 rpm
nominal
input speed

N2 R/MIN	i	M2 lb.in	Fm	lb	Unit Designation	lb	Motor Size
Output Speed	Ratio	Output Torque	Service Factor	Overhung Load	Column Entry 1 Through 20 Spaces to be filled when entering order	Weight of base mount unit	
606	2.9	7578	2.03	8224	M 1 3 2 1 2 . 8 _ N _ _ _ _ 7 5 . B - -	1280.5	365TC
552	3.19	8319	2.03	8448	3 . 2		
484	3.64	9451	2.03	8760	3 . 6		
437	4.03	10540	2.03	9014	4 . 0		
398	4.42	11586	2.03	9230	4 . 5		
349	5.04	13154	2.03	9580	5 . 0		
318	5.54	14460	2.03	9751	5 . 6		
283	6.21	16246	2.03	9845	6 . 3		
256	6.88	17988	2.03	9948	7 . 1		
226	7.78	20297	2.03	10058	8 . 0		
204	8.62	22475	2.03	10129	9 . 0		
178	9.89	25872	2.03	10202	1 0 ,		
157	11.2	29294	1.79	10227	1 1 ,		
142	12.39	32211	1.72	10302	1 2 ,		
125	14.03	36507	1.52	10280	1 4 ,		
110	15.97	41574	1.32	10114	1 6 ,		
98	18	46875	1.17	9983	1 8 ,		
88	20	51916	1.08	10408	2 0 ,		
78	22.55	58527	0.96	10206	2 2 ,		
69	25.45	66051	0.83	9846	2 5 ,		
610	2.89	7517	2.97	10654	M 1 4 2 1 2 . 8 _ N _ _ _ _ 7 5 . B - -	1525.2	365TC
542	3.25	8471	2.97	11005	3 . 2		
460	3.82	9933	2.97	11535	3 . 6		
437	4.03	10500	2.97	11715	4 . 0		
388	4.54	11842	2.97	12110	4 . 5		
330	5.33	13900	2.97	12669	5 . 0		
293	6	15630	2.97	12959	5 . 6		
269	6.55	17092	2.97	13085	6 . 3		
242	7.27	19001	2.97	13233	7 . 1		
203	8.67	22580	2.97	13468	8 . 0		
183	9.62	25086	2.97	13600	9 . 0		
175	10.06	26145	2.82	13704	1 0 ,		
154	11.43	29737	2.57	13955	1 1 ,		
132	13.32	34385	2.63	14233	1 2 ,		
116	15.13	39375	2.34	14481	1 4 ,		
107	16.43	42792	1.94	14657	1 6 ,		
97	18.11	47220	1.82	14833	1 8 ,		
81	21.75	56341	1.67	14644	2 0 ,		
73	23.97	62243	1.54	14536	2 2 ,		
68	26.07	67498	1.31	14772	2 5 ,		
62	28.25	73131	1.21	14708	2 8 ,		
51	34.51	89412	1.06	14251	3 2 ,		
47	37.39	96647	0.99	15196	3 6 ,		
45	39.42	101338	0.85	16815	4 0 ,		

NOTE
Other output
speeds are
available
using 2 and 6
pole motors
- Consult
Application
Engineering

SERIES M

SELECTION TABLES

GEARED MOTORS

100 HP

4 POLE
1750 rpm
nominal
input speed

N2 R/MIN	i	M2 lb.in	Fm	lb	Unit Designation	lb	Motor Size
Output Speed	Ratio	Output Torque	Service Factor	Overhung Load	Column Entry 1 Through 20 Spaces to be filled when entering order	Weight of base mount unit	
606	2.9	10105	1.52	8138	M 1 3 2 1 2 . 8 _ N _ _ _ _ 1 0 0 B _ _	1764.4	405TC
552	3.19	11092	1.52	8362	3 . 2		
484	3.64	12602	1.52	8655	3 . 6		
437	4.03	14054	1.52	8902	4 . 0		
398	4.42	15448	1.52	9104	4 . 5		
349	5.04	17538	1.52	9441	5 . 0		
318	5.54	19280	1.52	9599	5 . 6		
283	6.21	21662	1.52	9666	6 . 3		
256	6.88	23985	1.52	9756	7 . 1		
226	7.78	27063	1.52	9846	8 . 0		
204	8.62	29966	1.52	9891	9 . 0		
178	9.89	34496	1.52	9891	1 0 ,		
157	11.2	39059	1.35	9824	1 1 ,		
142	12.39	42948	1.29	9846	1 2 ,		
125	14.03	48677	1.14	9711	1 4 ,		
110	15.97	55432	0.99	9419	1 6 ,		
98	18	62500	0.88	9149	1 8 ,		
610	2.89	10022	2.23	10588	M 1 4 2 1 2 . 8 _ N _ _ _ _ 1 0 0 B _ _	2015.7	405TC
542	3.25	11295	2.23	10925	3 . 2		
460	3.82	13244	2.23	11442	3 . 6		
437	4.03	14000	2.23	11622	4 . 0		
388	4.54	15789	2.23	12004	4 . 5		
330	5.33	18534	2.23	12544	5 . 0		
293	6	20840	2.23	12814	5 . 6		
269	6.55	22789	2.23	12926	6 . 3		
242	7.27	25335	2.23	13061	7 . 1		
203	8.67	30107	2.23	13263	8 . 0		
183	9.62	33448	2.23	13376	9 . 0		
175	10.06	34860	2.12	13466	1 0 ,		
154	11.43	39650	1.93	13690	1 1 ,		
132	13.32	45847	1.97	13915	1 2 ,		
116	15.13	52500	1.75	14117	1 4 ,		
107	16.43	57057	1.46	14275	1 6 ,		
97	18.11	62961	1.36	14410	1 8 ,		
81	21.75	75121	1.25	13960	2 0 ,		
73	23.97	82991	1.15	13713	2 2 ,		
68	26.07	89997	0.98	13937	2 5 ,		
62	28.25	97508	0.9	13758	2 8 ,		

NOTE
Other output
speeds are
available
using 2 and 6
pole motors
- Consult
Application
Engineering

SERIES M

DIMENSIONS - DOUBLE REDUCTION BASE MOUNT

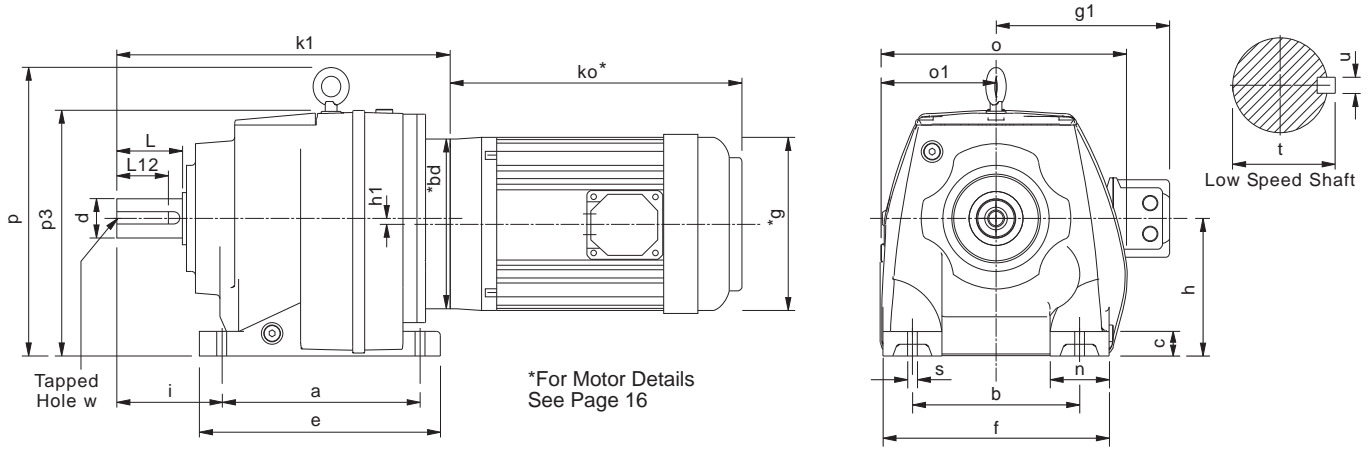

SIZE	a	b	c	e	f	h	h1	i	n	o	o1	p	p3	s	Low Speed Shaft					
															d	L	L12	t	u	w
M0122	4.33	4.33	0.47	5.16	5.31	2.95	-	2.28	0.98	5.98	2.99	-	5.87	0.39	0.750	1.575	1 9/32	0.829	3/16	1/4 UNF x 0.63 deep
M0222	5.12	4.33	0.63	5.98	5.71	3.54	-	2.95	1.38	6.69	3.31	-	7.09	0.39	1.000	1.969	1 9/16	1.106	1/4	1/4 UNF x 0.71 deep
M0322	5.12	4.33	0.63	5.98	5.71	3.54	-	2.95	1.38	6.69	3.31	-	7.09	0.39	1.000	1.969	1 9/16	1.106	1/4	1/4 UNF x 0.71 deep
M0422	6.50	5.31	0.79	7.87	7.48	4.53	-	3.54	2.17	8.03	3.82	-	8.19	0.59	1.250	2.362	2	1.359	1/4	3/8 UNF x 0.86 deep
M0522	6.50	5.31	0.79	7.87	7.48	4.53	-	3.94	2.17	8.03	3.82	-	8.19	0.59	1.375	2.756	2 3/8	1.507	5/16	3/8 UNF x 0.75 deep
M0622	7.68	5.91	0.94	9.25	8.27	5.12	0.57	3.94	2.36	8.66	4.33	9.69	8.43	0.59	1.375	2.756	2 3/8	1.507	5/16	3/8 UNF x 0.75 deep
M0722	8.07	6.69	0.98	9.65	9.06	5.51	-	4.53	2.36	9.92	4.69	11.61	9.84	0.75	1.625	3.150	2 3/8	1.784	3/8	5/8 UNF x 1.25 deep
M0822	10.24	8.46	1.38	12.20	11.42	7.09	-	5.51	2.95	12.60	6.57	14.17	12.20	0.75	2.125	3.937	2 3/4	2.338	1/2	3/4 UNF x 1.50 deep
M0921	12.20	9.84	1.57	14.37	13.39	8.86	-	6.30	3.54	14.65	7.87	17.05	15.51	0.91	2.375	4.720	3 11/16	2.65	0.625	3/4 UNF x 1.65 deep
M1021	14.57	11.42	1.77	17.32	15.75	9.84	-	7.28	4.33	16.85	8.86	19.88	17.56	1.06	2.875	5.510	4 5/8	3.2	0.75	3/4 UNF x 1.65 deep
M1321	16.14	13.39	1.97	19.29	17.72	10.43	-	8.66	4.33	18.50	9.53	22.17	19.02	1.34	3.625	6.690	5 15/16	4.01	0.875	1 UNF x 1.97 deep
M1421	19.69	14.96	1.97	23.23	20.87	11.81	-	10.24	5.91	21.50	10.94	24.80	21.69	1.61	4.000	8.270	7 1/2	4.44	1.00	1 UNF x 1.97 deep

MOTOR FRAME SIZE	M0122	M0222	M0322	M0422	M0522	M0622	M0722	M0822	M0921	M1021	M1321	M1421
	K1	K1	K1	K1	K1	K1	K1	K1	K1	K1	K1	K1
56C	9.45	10.67	10.67	12.13	12.52	13.35	14.84	19.06	-	-	-	-
143-145TC	9.45	10.67	10.67	12.13	12.52	13.35	14.84	19.06	-	-	-	-
182-184TC	9.13	10.35	10.35	13.11	13.50	14.33	15.20	19.06	20.83	23.98	28.46	32.99
213-215TC	-	-	-	13.11	13.50	14.33	15.20	19.06	20.83	23.98	28.46	32.99
254-256TC	-	-	-	-	-	-	15.12	19.06	22.20	25.16	28.46	32.99
284-286TC	-	-	-	-	-	-	-	-	22.32	25.28	28.58	33.11
324-326TC	-	-	-	-	-	-	-	-	22.99	25.91	29.21	33.74
364-365TC	-	-	-	-	-	-	-	-	-	-	35.91	40.43
404-405TC	-	-	-	-	-	-	-	-	-	-	37.28	41.81

SERIES M

DIMENSIONS - TRIPLE REDUCTION BASE MOUNT

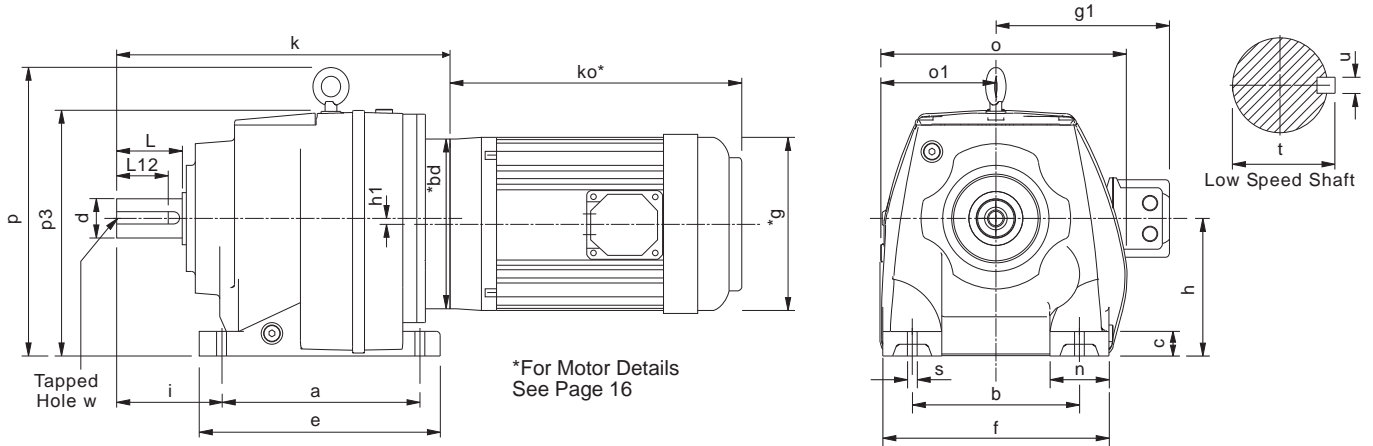

SIZE	a	b	c	e	f	h	h1	i	n	o	o1	p	p3	s	Low Speed Shaft					
															d	L	L12	t	u	w
M0132	4.33	4.33	0.47	5.16	5.31	2.95	-	2.28	0.98	5.98	2.99	-	5.87	0.39	0.750	1.575	1 9/32	0.829	3/16	1/4 UNF x 0.63 deep
M0232	5.12	4.33	0.63	5.98	5.71	3.54	-	2.95	1.38	6.69	3.31	-	7.09	0.39	1.000	1.969	1 9/16	1.106	1/4	1/4 UNF x 0.71 deep
M0332	5.12	4.33	0.63	5.98	5.71	3.54	-	2.95	1.38	6.69	3.31	-	7.09	0.39	1.000	1.969	1 9/16	1.106	1/4	1/4 UNF x 0.71 deep
M0432	6.50	5.31	0.79	7.87	7.48	4.53	-	3.54	2.17	8.03	3.82	-	8.19	0.59	1.250	2.362	2	1.359	1/4	3/8 UNF x 0.86 deep
M0532	6.50	5.31	0.79	7.87	7.48	4.53	-	3.94	2.17	8.03	3.82	-	8.19	0.59	1.375	2.756	2 3/8	1.507	5/16	3/8 UNF x 0.75 deep
M0632	7.68	5.91	0.94	9.25	8.27	5.12	0.57	3.94	2.36	8.66	4.33	9.69	8.43	0.59	1.375	2.756	2 3/8	1.507	5/16	3/8 UNF x 0.75 deep
M0732	8.07	6.69	0.98	9.65	9.06	5.51	-	4.53	2.36	9.92	4.69	11.61	9.84	0.75	1.625	3.150	2 3/8	1.784	3/8	5/8 UNF x 1.25 deep
M0832	10.24	8.46	1.38	12.20	11.42	7.09	-	5.51	2.95	12.60	6.57	14.17	12.20	0.75	2.125	3.937	2 3/4	2.338	1/2	3/4 UNF x 1.50 deep
M0931	12.20	9.84	1.57	14.37	13.39	8.86	-	6.30	3.54	14.65	7.87	17.05	15.51	0.91	2.375	4.720	3 11/16	2.65	0.625	3/4 UNF x 1.65 deep
M1031	14.57	11.42	1.77	17.32	15.75	9.84	-	7.28	4.33	16.85	8.86	19.88	17.56	1.06	2.875	5.510	4 5/8	3.2	0.75	3/4 UNF x 1.65 deep
M1331	16.14	13.39	1.97	19.29	17.72	10.43	-	8.66	4.33	18.50	9.53	22.17	19.02	1.34	3.625	6.690	5 15/16	4.01	0.875	1 UNF x 1.97 deep
M1431	19.69	14.96	1.97	23.23	20.87	11.81	-	10.24	5.91	21.50	10.94	24.80	21.69	1.61	4.000	8.270	7 1/2	4.44	1.00	1 UNF x 1.97 deep

MOTOR FRAME SIZE	M0132	M0232	M0332	M0432	M0532	M0632	M0732	M0832	M0931	M1031	M1331	M1431
	K1	K1	K1	K1	K1	K1	K1	K1	K1	K1	K1	K1
56C	10.04	11.18	11.18	13.03	13.43	14.25	15.39	18.78	21.89	-	-	-
143-145TC	10.04	11.18	11.18	13.03	13.43	14.25	15.39	18.78	21.89	-	-	-
182-184TC	9.72	10.87	10.87	12.72	13.11	13.94	16.38	19.13	21.89	25.71	30.91	35.83
213-215TC	-	-	-	-	-	-	16.38	19.13	-	25.71	30.91	35.83
254-256TC	-	-	-	-	-	-	-	19.06	-	27.09	30.91	35.83
284-286TC	-	-	-	-	-	-	-	-	-	-	31.02	35.94
324-326TC	-	-	-	-	-	-	-	-	-	-	31.65	36.57
364-365TC	-	-	-	-	-	-	-	-	-	-	38.35	43.27
404-405TC	-	-	-	-	-	-	-	-	-	-	39.72	44.65

SERIES M

DIMENSIONS - QUADRUPLE REDUCTION BASE MOUNT

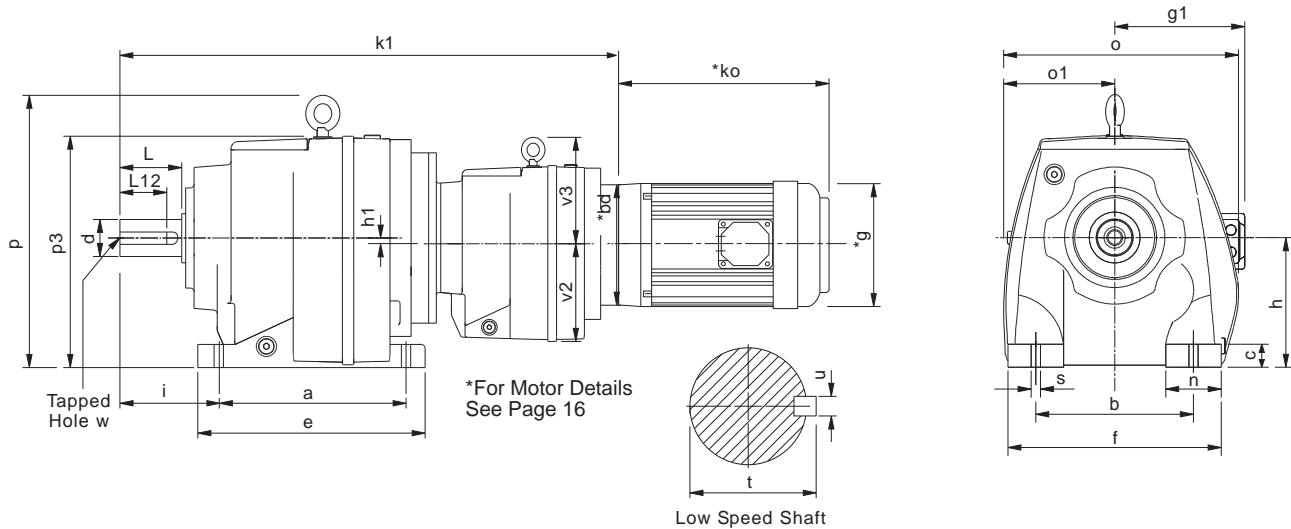

SIZE	a	b	c	e	f	h	h1	i	n	o	o1	p	p3	s	Low Speed Shaft					
															d	L	L12	t	u	w
M0142	4.33	4.33	0.47	5.16	5.31	2.95	-	2.28	0.98	5.98	2.99	-	5.87	0.39	0.750	1.575	1 9/32	0.829	3/16	1/4 UNF x 0.63 deep
M0242	5.12	4.33	0.63	5.98	5.71	3.54	-	2.95	1.38	6.69	3.31	-	7.09	0.39	1.000	1.969	1 9/16	1.106	1/4	1/4 UNF x 0.71 deep
M0342	5.12	4.33	0.63	5.98	5.71	3.54	-	2.95	1.38	6.69	3.31	-	7.09	0.39	1.000	1.969	1 9/16	1.106	1/4	1/4 UNF x 0.71 deep
M0442	6.50	5.31	0.79	7.87	7.48	4.53	-	3.54	2.17	8.03	3.82	-	8.19	0.59	1.250	2.362	2	1.359	1/4	3/8 UNF x 0.86 deep
M0542	6.50	5.31	0.79	7.87	7.48	4.53	-	3.94	2.17	8.03	3.82	-	8.19	0.59	1.375	2.756	2 3/8	1.507	5/16	3/8 UNF x 0.75 deep
M0642	7.68	5.91	0.94	9.25	8.27	5.12	0.57	3.94	2.36	8.66	4.33	9.69	8.43	0.59	1.375	2.756	2 3/8	1.507	5/16	3/8 UNF x 0.75 deep
M0742	8.07	6.69	0.98	9.65	9.06	5.51	-	4.53	2.36	9.92	4.69	11.61	9.84	0.75	1.625	3.150	2 3/8	1.784	3/8	5/8 UNF x 1.25 deep
M0842	10.24	8.46	1.38	12.20	11.42	7.09	-	5.51	2.95	12.60	6.57	14.17	12.20	0.75	2.125	3.937	2 3/4	2.338	1/2	3/4 UNF x 1.50 deep
M0941	12.20	9.84	1.57	14.37	13.39	8.86	-	6.30	3.54	14.65	7.87	17.05	15.51	0.91	2.375	4.720	3 11/16	2.65	0.625	3/4 UNF x 1.65 deep
M1041	14.57	11.42	1.77	17.32	15.75	9.84	-	7.28	4.33	16.85	8.86	19.88	17.56	1.06	2.875	5.510	4 5/8	3.2	0.75	3/4 UNF x 1.65 deep
M1341	16.14	13.39	1.97	19.29	17.72	10.43	-	8.66	4.33	18.50	9.53	22.17	19.02	1.34	3.625	6.690	5 15/16	4.01	0.875	1 UNF x 1.97 deep
M1441	19.69	14.96	1.97	23.23	20.87	11.81	-	10.24	5.91	21.50	10.94	24.80	21.69	1.61	4.000	8.270	7 1/2	4.44	1.00	1 UNF x 1.97 deep

MOTOR FRAME SIZE	M0342	M0442	M0542	M0642	M0742	M0842	M0941	M1041	M1341	M1441
	K1	K1	K1	K1	K1	K1	K1	K1	K1	K1
56C	17.99	20.67	21.06	21.89	23.35	27.17	30.35	35.16	39.92	44.45
143-145TC	17.99	32.67	21.06	21.89	23.35	27.17	30.35	35.16	39.92	44.45
182-184TC	17.68	35.85	20.75	21.57	23.03	28.15	31.34	35.51	40.28	44.80
213-215TC	-	-	-	-	-	28.15	31.34	35.51	40.28	44.80

SERIES M

DIMENSIONS - QUINTUPLE REDUCTION BASE MOUNT

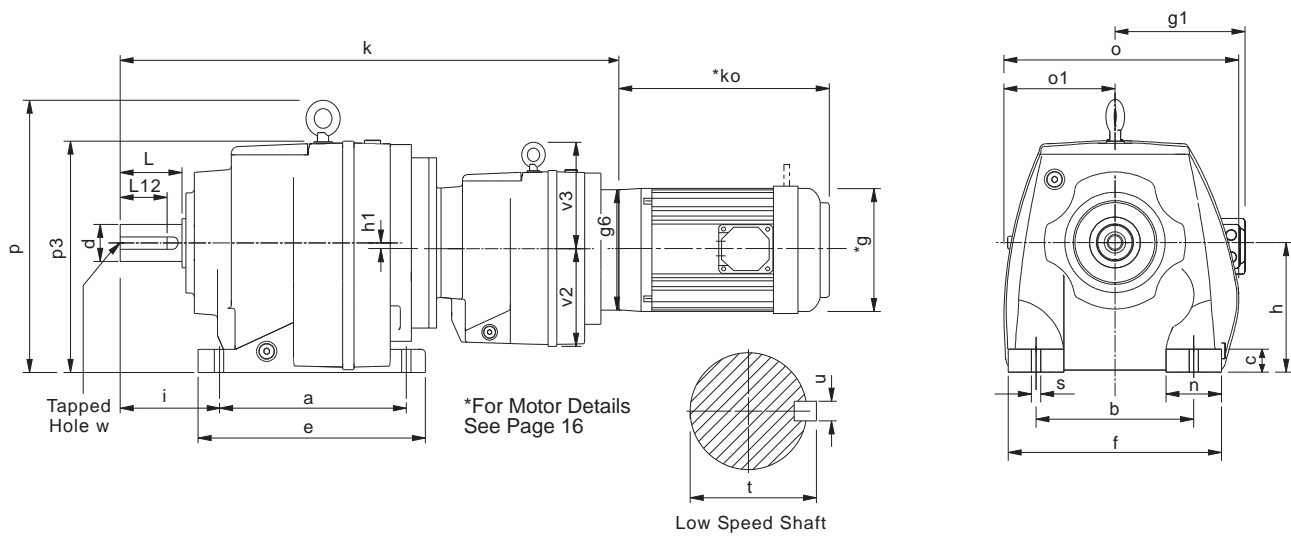

SIZE	a	b	c	e	f	h	h1	i	n	o	o1	p	p3	s	Low Speed Shaft					
															d	L	L12	t	u	w
M0152	4.33	4.33	0.47	5.16	5.31	2.95	-	2.28	0.98	5.98	2.99	-	5.87	0.39	0.750	1.575	1 9/32	0.829	3/16	1/4 UNF x 0.63 deep
M0252	5.12	4.33	0.63	5.98	5.71	3.54	-	2.95	1.38	6.69	3.31	-	7.09	0.39	1.000	1.969	1 9/16	1.106	1/4	1/4 UNF x 0.71 deep
M0352	5.12	4.33	0.63	5.98	5.71	3.54	-	2.95	1.38	6.69	3.31	-	7.09	0.39	1.000	1.969	1 9/16	1.106	1/4	1/4 UNF x 0.71 deep
M0452	6.50	5.31	0.79	7.87	7.48	4.53	-	3.54	2.17	8.03	3.82	-	8.19	0.59	1.250	2.362	2	1.359	1/4	3/8 UNF x 0.86 deep
M0552	6.50	5.31	0.79	7.87	7.48	4.53	-	3.94	2.17	8.03	3.82	-	8.19	0.59	1.375	2.756	2 3/8	1.507	5/16	3/8 UNF x 0.75 deep
M0652	7.68	5.91	0.94	9.25	8.27	5.12	0.57	3.94	2.36	8.66	4.33	9.69	8.43	0.59	1.375	2.756	2 3/8	1.507	5/16	3/8 UNF x 0.75 deep
M0752	8.07	6.69	0.98	9.65	9.06	5.51	-	4.53	2.36	9.92	4.69	11.61	9.84	0.75	1.625	3.150	2 3/8	1.784	3/8	5/8 UNF x 1.25 deep
M0852	10.24	8.46	1.38	12.20	11.42	7.09	-	5.51	2.95	12.60	6.57	14.17	12.20	0.75	2.125	3.937	2 3/4	2.338	1/2	3/4 UNF x 1.50 deep
M0951	12.20	9.84	1.57	14.37	13.39	8.86	-	6.30	3.54	14.65	7.87	17.05	15.51	0.91	2.375	4.720	3 11/16	2.65	0.625	3/4 UNF x 1.65 deep
M1051	14.57	11.42	1.77	17.32	15.75	9.84	-	7.28	4.33	16.85	8.86	19.88	17.56	1.06	2.875	5.510	4 5/8	3.2	0.75	3/4 UNF x 1.65 deep
M1351	16.14	13.39	1.97	19.29	17.72	10.43	-	8.66	4.33	18.50	9.53	22.17	19.02	1.34	3.625	6.690	5 15/16	4.01	0.875	1 UNF x 1.97 deep
M1451	19.69	14.96	1.97	23.23	20.87	11.81	-	10.24	5.91	21.50	10.94	24.80	21.69	1.61	4.000	8.270	7 1/2	4.44	1.00	1 UNF x 1.97 deep

MOTOR FRAME SIZE	M0352	M0452	M0552	M0652	M0752	M0852	M0951	M1051	M1351	M1451
		K1	K1	K1	K1	K1	K1	K1	K1	K1
56C	18.58	21.18	21.57	22.40	23.86	28.07	31.26	35.71	40.47	45.00
143-145TC	18.58	21.18	21.57	22.40	23.86	28.07	31.26	35.71	40.47	45.00
182-184TC	18.27	20.87	21.26	22.09	23.54	27.76	30.94	36.69	41.46	45.98

SERIES M

DIMENSIONS - DOUBLE REDUCTION FLANGE MOUNT

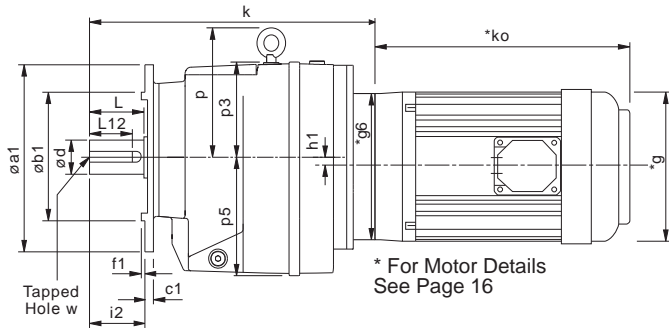

Sizes
1, 2, 3, 4, 5, 6, 7 and 8

Sizes
9, 10, 13 and 14

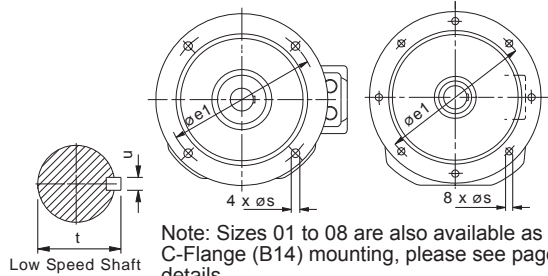

SIZE	Øa1	Øb1	c1	Øe1	f1	h1	i2	p	p3	p5	s	Low Speed Shaft					
												d	L	L12	t	u	w
M0122	4.72	3.15	0.35	3.94	0.12	-	1.57	-	2.91	2.99	0.35	0.75	1.575	1 9/32	0.829	3/16	1/4 UNF x 0.63 deep
	5.51	3.74	0.35	4.53	0.12	-	1.57	-	2.91	2.99	0.35						
	6.30	4.33	0.39	5.12	0.14	-	1.57	-	2.91	2.99	0.35						
	7.87	5.12	0.39	6.50	0.14	-	1.57	-	2.91	2.99	0.43						
M0222	4.72	3.15	0.39	3.94	0.12	-	1.97	-	3.54	3.58	0.26	1	1.969	1 9/16	1.106	1/4	1/4 UNF x 0.63 deep
	5.51	3.74	0.39	4.53	0.12	-	1.97	-	3.54	3.58	0.35						
	6.30	4.33	0.39	5.12	0.14	-	1.97	-	3.54	3.58	0.35						
	7.87	5.12	0.39	6.50	0.14	-	1.97	-	3.54	3.58	0.43						
M0322	4.72	3.15	0.39	3.94	0.12	-	1.97	-	3.54	3.58	0.26	1	1.969	1 9/16	1.106	1/4	1/4 UNF x 0.63 deep
	5.51	3.74	0.39	4.53	0.12	-	1.97	-	3.54	3.58	0.35						
	6.30	4.33	0.39	5.12	0.14	-	1.97	-	3.54	3.58	0.35						
	7.87	5.12	0.39	6.50	0.14	-	1.97	-	3.54	3.58	0.43						
M0422	5.51	3.74	0.43	4.53	0.12	-	2.36	-	3.66	4.53	0.35	1.25	2.362	2	1.359	1/4	1/4 UNF x 0.63 deep
	6.30	4.33	0.43	5.12	0.12	-	2.36	-	3.66	4.53	0.35						
	7.87	5.12	0.43	6.50	0.14	-	2.36	-	3.66	4.53	0.35						
	9.84	7.09	0.43	8.46	0.16	-	2.36	-	3.66	4.53	0.35						
M0522	5.51	3.74	0.43	4.53	0.12	-	2.76	-	3.66	4.53	0.35	1.375	2.756	2 3/8	1.507	5/16	1/4 UNF x 0.63 deep
	6.30	4.33	0.43	5.12	0.12	-	2.76	-	3.66	4.53	0.35						
	7.87	5.12	0.43	6.50	0.14	-	2.76	-	3.66	4.53	0.43						
	9.84	7.09	0.43	8.46	0.16	-	2.76	-	3.66	4.53	0.53						
M0622	7.87	5.12	0.43	6.50	0.16	0.57	2.76	-	3.66	4.53	0.43	1.375	2.756	2 3/8	1.507	5/16	1/4 UNF x 0.63 deep
	9.84	7.09	0.43	8.46	0.16	0.57	2.76	4.57	3.31	5.12	0.53						
	11.81	9.06	0.43	10.43	0.16	0.57	2.76	4.57	3.31	5.12	0.53						
M0722	7.87	5.12	0.43	6.50	0.14	-	3.15	-	4.33	5.51	0.43	1.625	3.15	2 3/8	1.784	3/8	1/4 UNF x 0.63 deep
	9.84	7.09	0.43	8.46	0.16	-	3.15	6.1	4.33	5.51	0.53						
	11.81	9.06	0.43	10.43	0.16	-	3.15	6.1	4.33	5.51	0.53						
M0822	11.81	9.06	0.67	10.43	0.16	-	3.94	7.09	5.12	7.17	0.53	2.125	3.937	2 3/4	2.338	1/2	1/4 UNF x 0.63 deep
	13.78	9.84	0.67	11.81	0.20	-	3.94	7.09	5.12	7.17	0.69						
M0921	17.72	13.78	0.71	15.75	0.20	-	5.51	7.8	-	9.06	0.71	2.375	4.72	3 11/16	2.65	0.625	1/4 UNF x 0.63 deep
M1021	17.72	13.78	0.87	15.75	0.20	-	5.51	9.65	-	10.24	0.71	2.875	5.51	4 5/8	3.2	0.75	1/4 UNF x 0.63 deep
M1321	21.65	17.72	0.98	19.69	0.20	-	6.69	11.34	-	10.94	0.71	3.625	6.69	5 15/16	4.01	0.875	1/4 UNF x 0.63 deep
M1421	21.65	17.72	0.98	19.69	0.20	-	8.27	12.6	-	12.52	0.71	4.00	8.27	7 1/2	4.44	1.00	1/4 UNF x 0.63 deep

MOTOR FRAME SIZE	M0122	M0222	M0322	M0422	M0522	M0622	M0722	M0822	M0921	M1021	M1321	M1421
	K1	K1	K1	K1	K1	K1	K1	K1	K1	K1	K1	K1
56C	9.45	10.67	10.67	12.13	12.52	13.35	14.84	19.06	-	-	-	-
143-145TC	9.45	10.67	10.67	12.13	12.52	13.35	14.84	19.06	-	-	-	-
182-184TC	9.13	10.35	10.35	13.11	13.50	14.33	15.20	19.06	20.83	23.98	28.46	32.99
213-215TC	-	-	-	13.11	13.50	14.33	15.20	19.06	20.83	23.98	28.46	32.99
254-256TC	-	-	-	-	-	-	15.12	19.06	22.20	25.16	28.46	32.99
284-286TC	-	-	-	-	-	-	-	-	22.32	25.28	28.58	33.11
324-326TC	-	-	-	-	-	-	-	-	22.99	25.91	29.21	33.74
364-365TC	-	-	-	-	-	-	-	-	-	-	35.91	40.43
404-405TC	-	-	-	-	-	-	-	-	-	-	37.28	41.81

SERIES M

DIMENSIONS - TRIPLE REDUCTION FLANGE MOUNT

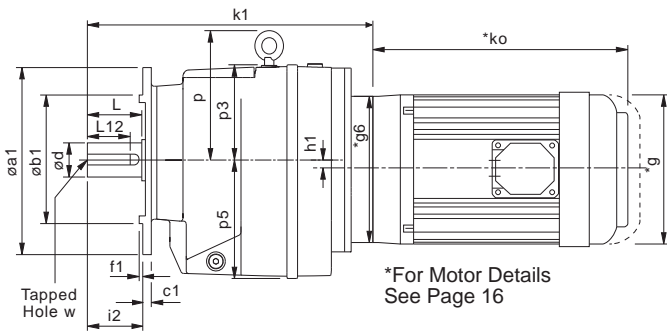

Sizes
1, 2, 3, 4, 5, 6, 7 and 8

Sizes
9, 10, 13 and 14

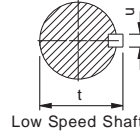
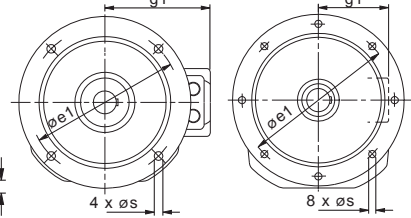

Note: Sizes 01 to 08 are also available as C-Flange (B14) mounting, please see page 82 for details

SIZE	Øa1	Øb1	c1	Øe1	f1	h1	i2	p	p3	p5	s	Low Speed Shaft					
												d	L	L12	t	u	w
M0132	4.72	3.15	0.35	3.94	0.12	-	1.57	-	2.91	2.99	0.35	0.75	1.575	1 9/32	0.829	3/16	1/4 UNF x 0.63 deep
	5.51	3.74	0.35	4.53	0.12	1.57	-	-	-	0.35							
	6.30	4.33	0.39	5.12	0.14	1.57	-	-	-	0.35							
	7.87	5.12	0.39	6.50	0.14	1.57	-	-	-	0.43							
M0232	4.72	3.15	0.39	3.94	0.12	-	1.97	-	3.54	3.58	0.26	1	1.969	1 9/16	1.106	1/4	1/4 UNF x 0.63 deep
	5.51	3.74	0.39	4.53	0.12	1.97	-	-	-	0.35							
	6.30	4.33	0.39	5.12	0.14	1.97	-	-	-	0.35							
	7.87	5.12	0.39	6.50	0.14	1.97	-	-	-	0.43							
M0332	4.72	3.15	0.39	3.94	0.12	-	1.97	-	3.54	3.58	0.26	1	1.969	1 9/16	1.106	1/4	1/4 UNF x 0.63 deep
	5.51	3.74	0.39	4.53	0.12	1.97	-	-	-	0.35							
	6.30	4.33	0.39	5.12	0.14	1.97	-	-	-	0.35							
	7.87	5.12	0.39	6.50	0.14	1.97	-	-	-	0.43							
M0432	5.51	3.74	0.43	4.53	0.12	-	2.36	-	3.66	4.53	0.35	1.25	2.362	2	1.359	1/4	1/4 UNF x 0.63 deep
	6.30	4.33	0.43	5.12	0.12	2.36	-	-	-	0.35							
	7.87	5.12	0.43	6.50	0.14	2.36	-	-	-	0.35							
	9.84	7.09	0.43	8.46	0.16	2.36	-	-	-	0.35							
M0532	5.51	3.74	0.43	4.53	0.12	-	2.76	-	3.66	4.53	0.35	1.375	2.756	2 3/8	1.507	5/16	1/4 UNF x 0.63 deep
	6.30	4.33	0.43	5.12	0.12	2.76	-	-	-	0.43							
	7.87	5.12	0.43	6.50	0.14	2.76	-	-	-	0.53							
	9.84	7.09	0.43	8.46	0.16	2.76	-	-	-	0.53							
M0632	7.87	5.12	0.43	6.50	0.16	0.57	2.76	4.57	3.31	5.12	0.43	1.375	2.756	2 3/8	1.507	5/16	1/4 UNF x 0.63 deep
	9.84	7.09	0.43	8.46	0.16		2.76				0.53						
	11.81	9.06	0.43	10.43	0.16		2.76				0.53						
M0732	7.87	5.12	0.43	6.50	0.14	-	3.15	6.1	4.33	5.51	0.43	1.625	3.15	2 3/8	1.784	3/8	1/4 UNF x 0.63 deep
	9.84	7.09	0.43	8.46	0.16		3.15				0.53						
	11.81	9.06	0.43	10.43	0.16		3.15				0.53						
M0832	11.81	9.06	0.67	10.43	0.16	-	3.94	7.09	5.12	7.17	0.53	2.125	3.937	2 3/4	2.338	1/2	1/4 UNF x 0.63 deep
	13.78	9.84	0.67	11.81	0.20		3.94				0.69						
M0931	17.72	13.78	0.71	15.75	0.20	-	5.51	7.8	-	9.06	0.71	2.375	4.72	3 11/16	2.65	0.625	1/4 UNF x 0.63 deep
M1031	17.72	13.78	0.87	15.75	0.20	-	5.51	9.65	-	10.24	0.71	2.875	5.51	4 5/8	3.2	0.75	1/4 UNF x 0.63 deep
M1331	21.65	17.72	0.98	19.69	0.20	-	6.69	11.34	-	10.94	0.71	3.625	6.69	5 15/16	4.01	0.875	1/4 UNF x 0.63 deep
M1431	21.65	17.72	0.98	19.69	0.20	-	8.27	12.6	-	12.52	0.71	4.00	8.27	7 1/2	4.44	1.00	1/4 UNF x 0.63 deep

MOTOR FRAME SIZE	M0132	M0232	M0332	M0432	M0532	M0632	M0732	M0832	M0931	M1031	M1331	M1431
	K1	K1	K1	K1	K1	K1	K1	K1	K1	K1	K1	K1
56C	10.04	11.18	11.18	13.03	13.43	14.25	15.39	18.78	21.89	-	-	-
143-145TC	10.04	11.18	11.18	13.03	13.43	14.25	15.39	18.78	21.89	-	-	-
182-184TC	9.72	10.87	10.87	12.72	13.11	13.94	16.38	19.13	21.89	25.71	30.91	35.83
213-215TC	-	-	-	-	-	-	16.38	19.13	-	25.71	30.91	35.83
254-256TC	-	-	-	-	-	-	-	19.06	-	27.09	30.91	35.83
284-286TC	-	-	-	-	-	-	-	-	-	-	31.02	35.94
324-326TC	-	-	-	-	-	-	-	-	-	-	31.65	36.57
364-365TC	-	-	-	-	-	-	-	-	-	-	38.35	43.27
404-405TC	-	-	-	-	-	-	-	-	-	-	39.72	44.65

SERIES M

DIMENSIONS - QUADRUPLE REDUCTION FLANGE MOUNT

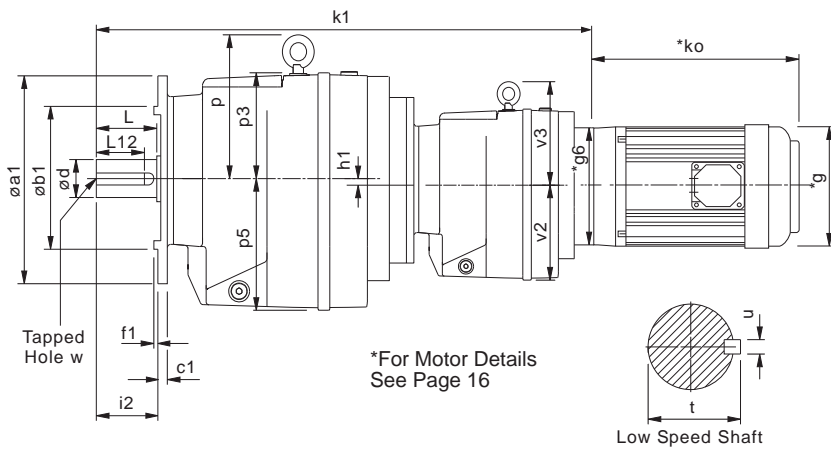

Sizes
3, 4, 5, 6, 7 and 8

Sizes
9, 10, 13 and 14

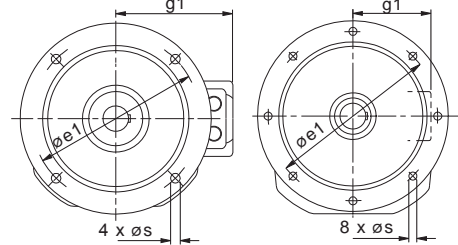

Note: Sizes 01 to 08 are also available as C-Flange (B14) mounting, please see page 82 for details

SIZE	Øa1	Øb1	c1	Øe1	f1	h1	i2	p	p3	p5	s	Low Speed Shaft					
												d	L	L12	t	u	w
M0142	4.72	3.15	0.35	3.94	0.12	-	1.57	-	2.91	2.99	0.35	0.75	1.575	1 9/32	0.829	3/16	1/4 UNF x 0.63 deep
	5.51	3.74	0.35	4.53	0.12	-	1.57	-	2.91	2.99	0.35						
	6.30	4.33	0.39	5.12	0.14	-	1.57	-	2.91	2.99	0.35						
	7.87	5.12	0.39	6.50	0.14	-	1.57	-	2.91	2.99	0.43						
M0242	4.72	3.15	0.39	3.94	0.12	-	1.97	-	3.54	3.58	0.26	1	1.969	1 9/16	1.106	1/4	1/4 UNF x 0.63 deep
	5.51	3.74	0.39	4.53	0.12	-	1.97	-	3.54	3.58	0.35						
	6.30	4.33	0.39	5.12	0.14	-	1.97	-	3.54	3.58	0.35						
	7.87	5.12	0.39	6.50	0.14	-	1.97	-	3.54	3.58	0.43						
M0342	4.72	3.15	0.39	3.94	0.12	-	1.97	-	3.54	3.58	0.26	1	1.969	1 9/16	1.106	1/4	1/4 UNF x 0.63 deep
	5.51	3.74	0.39	4.53	0.12	-	1.97	-	3.54	3.58	0.35						
	6.30	4.33	0.39	5.12	0.14	-	1.97	-	3.54	3.58	0.35						
	7.87	5.12	0.39	6.50	0.14	-	1.97	-	3.54	3.58	0.43						
M0442	5.51	3.74	0.43	4.53	0.12	-	2.36	-	3.66	4.53	0.35	1.25	2.362	2	1.359	1/4	1/4 UNF x 0.63 deep
	6.30	4.33	0.43	5.12	0.12	-	2.36	-	3.66	4.53	0.35						
	7.87	5.12	0.43	6.50	0.14	-	2.36	-	3.66	4.53	0.35						
	9.84	7.09	0.43	8.46	0.16	-	2.36	-	3.66	4.53	0.35						
M0542	5.51	3.74	0.43	4.53	0.12	-	2.76	-	3.66	4.53	0.35	1.375	2.756	2 3/8	1.507	5/16	1/4 UNF x 0.63 deep
	6.30	4.33	0.43	5.12	0.12	-	2.76	-	3.66	4.53	0.35						
	7.87	5.12	0.43	6.50	0.14	-	2.76	-	3.66	4.53	0.43						
	9.84	7.09	0.43	8.46	0.16	-	2.76	-	3.66	4.53	0.53						
M0642	7.87	5.12	0.43	6.50	0.16	0.57	2.76	4.57	3.31	5.12	0.43	1.375	2.756	2 3/8	1.507	5/16	1/4 UNF x 0.63 deep
	9.84	7.09	0.43	8.46	0.16	0.57	2.76	4.57	3.31	5.12	0.53						
	11.81	9.06	0.43	10.43	0.16	0.57	2.76	4.57	3.31	5.12	0.53						
	7.87	5.12	0.43	6.50	0.14	-	3.15	6.1	4.33	5.51	0.43						
M0742	9.84	7.09	0.43	8.46	0.16	-	3.15	6.1	4.33	5.51	0.53	1.625	3.15	2 3/8	1.784	3/8	1/4 UNF x 0.63 deep
	11.81	9.06	0.43	10.43	0.16	-	3.15	6.1	4.33	5.51	0.53						
	11.81	9.06	0.67	10.43	0.16	-	3.94	7.09	5.12	7.17	0.53						
M0842	13.78	9.84	0.67	11.81	0.20	-	3.94	7.09	5.12	7.17	0.69	2.125	3.937	2 3/4	2.338	1/2	1/4 UNF x 0.63 deep
	17.72	13.78	0.71	15.75	0.20	-	5.51	7.8	-	9.06	0.71						
M0941	17.72	13.78	0.87	15.75	0.20	-	5.51	9.65	-	10.24	0.71	2.375	4.72	3 11/16	2.65	0.625	1/4 UNF x 0.63 deep
M1041	21.65	17.72	0.98	19.69	0.20	-	6.69	11.34	-	10.94	0.71	2.875	5.51	4 5/8	3.2	0.75	1/4 UNF x 0.63 deep
M1341	21.65	17.72	0.98	19.69	0.20	-	6.69	11.34	-	10.94	0.71	3.625	6.69	5 15/16	4.01	0.875	1/4 UNF x 0.63 deep
M1441	21.65	17.72	0.98	19.69	0.20	-	8.27	12.6	-	12.52	0.71	4.00	8.27	7 1/2	4.44	1.00	1/4 UNF x 0.63 deep

MOTOR FRAME SIZE	M0342	M0442	M0542	M0642	M0742	M0842	M0941	M1041	M1341	M1441
	K1	K1	K1	K1	K1	K1	K1	K1	K1	K1
56C	17.99	20.67	21.06	21.89	23.35	27.17	30.35	35.16	39.92	44.45
143-145TC	17.99	32.67	21.06	21.89	23.35	27.17	30.35	35.16	39.92	44.45
182-184TC	17.68	35.85	20.75	21.57	23.03	28.15	31.34	35.51	40.28	44.80
213-215TC	-	-	-	-	-	28.15	31.34	35.51	40.28	44.80

SERIES M

DIMENSIONS - QUINTUPLE REDUCTION FLANGE MOUNT

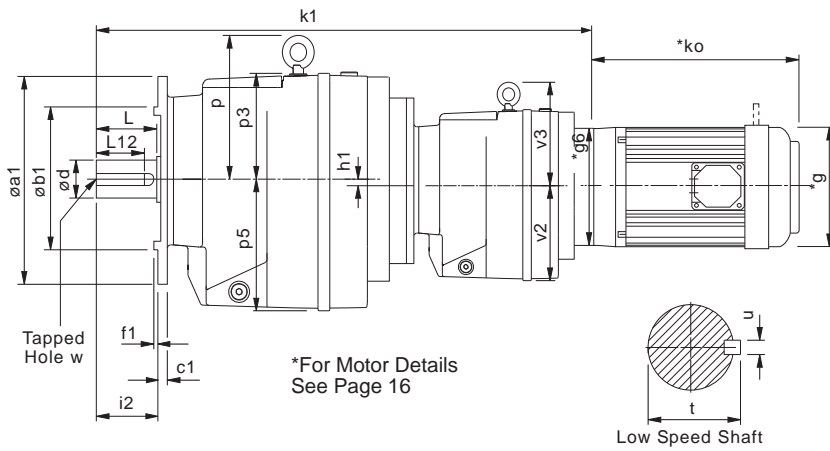

Sizes
3, 4, 5, 6, 7 and 8

Sizes
9, 10, 13 and 14

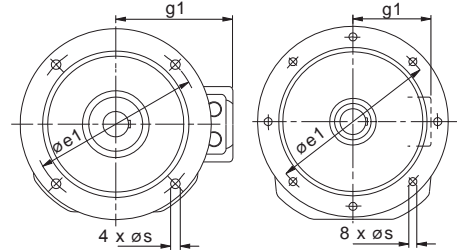

Note: Sizes 01 to 08 are also available as C-Flange (B14) mounting, please see page 82 for details

SIZE	Øa1	Øb1	c1	Øe1	f1	h1	i2	p	p3	p5	s	Low Speed Shaft					
												d	L	L12	t	u	w
M0152	4.72	3.15	0.35	3.94	0.12	-	1.57	-	2.91	2.99	0.35	0.75	1.575	1 9/32	0.829	3/16	1/4 UNF x 0.63 deep
	5.51	3.74	0.35	4.53	0.12	-	1.57	-	2.91	2.99	0.35						
	6.30	4.33	0.39	5.12	0.14	-	1.57	-	2.91	2.99	0.35						
	7.87	5.12	0.39	6.50	0.14	-	1.57	-	2.91	2.99	0.43						
M0252	4.72	3.15	0.39	3.94	0.12	-	1.97	-	3.54	3.58	0.26	1	1.969	1 9/16	1.106	1/4	1/4 UNF x 0.63 deep
	5.51	3.74	0.39	4.53	0.12	-	1.97	-	3.54	3.58	0.35						
	6.30	4.33	0.39	5.12	0.14	-	1.97	-	3.54	3.58	0.35						
	7.87	5.12	0.39	6.50	0.14	-	1.97	-	3.54	3.58	0.43						
M0352	4.72	3.15	0.39	3.94	0.12	-	1.97	-	3.54	3.58	0.26	1	1.969	1 9/16	1.106	1/4	1/4 UNF x 0.63 deep
	5.51	3.74	0.39	4.53	0.12	-	1.97	-	3.54	3.58	0.35						
	6.30	4.33	0.39	5.12	0.14	-	1.97	-	3.54	3.58	0.35						
	7.87	5.12	0.39	6.50	0.14	-	1.97	-	3.54	3.58	0.43						
M0452	5.51	3.74	0.43	4.53	0.12	-	2.36	-	3.66	4.53	0.35	1.25	2.362	2	1.359	1/4	1/4 UNF x 0.63 deep
	6.30	4.33	0.43	5.12	0.12	-	2.36	-	3.66	4.53	0.35						
	7.87	5.12	0.43	6.50	0.14	-	2.36	-	3.66	4.53	0.35						
	9.84	7.09	0.43	8.46	0.16	-	2.36	-	3.66	4.53	0.35						
M0552	5.51	3.74	0.43	4.53	0.12	-	2.76	-	3.66	4.53	0.35	1.375	2.756	2 3/8	1.507	5/16	1/4 UNF x 0.63 deep
	6.30	4.33	0.43	5.12	0.12	-	2.76	-	3.66	4.53	0.35						
	7.87	5.12	0.43	6.50	0.14	-	2.76	-	3.66	4.53	0.43						
	9.84	7.09	0.43	8.46	0.16	-	2.76	-	3.66	4.53	0.53						
M0652	7.87	5.12	0.43	6.50	0.16	0.57	2.76	4.57	3.31	5.12	0.43	1.375	2.756	2 3/8	1.507	5/16	1/4 UNF x 0.63 deep
	9.84	7.09	0.43	8.46	0.16	0.57	2.76	4.57	3.31	5.12	0.53						
	11.81	9.06	0.43	10.43	0.16	0.57	2.76	4.57	3.31	5.12	0.53						
M0752	7.87	5.12	0.43	6.50	0.14	-	3.15	6.1	4.33	5.51	0.43	1.625	3.15	2 3/8	1.784	3/8	1/4 UNF x 0.63 deep
	9.84	7.09	0.43	8.46	0.16	-	3.15	6.1	4.33	5.51	0.53						
	11.81	9.06	0.43	10.43	0.16	-	3.15	6.1	4.33	5.51	0.53						
M0852	11.81	9.06	0.67	10.43	0.16	-	3.94	7.09	5.12	7.17	0.53	2.125	3.937	2 3/4	2.338	1/2	1/4 UNF x 0.63 deep
	13.78	9.84	0.67	11.81	0.20	-	3.94	7.09	5.12	7.17	0.69						
M0951	17.72	13.78	0.71	15.75	0.20	-	5.51	7.8	-	9.06	0.71	2.375	4.72	3 11/16	2.65	0.625	1/4 UNF x 0.63 deep
M1051	17.72	13.78	0.87	15.75	0.20	-	5.51	9.65	-	10.24	0.71	2.875	5.51	4 5/8	3.2	0.75	1/4 UNF x 0.63 deep
M1351	21.65	17.72	0.98	19.69	0.20	-	6.69	11.34	-	10.94	0.71	3.625	6.69	5 15/16	4.01	0.875	1/4 UNF x 0.63 deep
M1451	21.65	17.72	0.98	19.69	0.20	-	8.27	12.6	-	12.52	0.71	4.00	8.27	7 1/2	4.44	1.00	1/4 UNF x 0.63 deep

MOTOR FRAME SIZE	M0352	M0452	M0552	M0652	M0752	M0852	M0951	M1051	M1351	M1451
	K1	K1	K1	K1	K1	K1	K1	K1	K1	K1
56C	18.58	21.18	21.57	22.40	23.86	28.07	31.26	35.71	40.47	45.00
143-145TC	18.58	21.18	21.57	22.40	23.86	28.07	31.26	35.71	40.47	45.00
182-184TC	18.27	20.87	21.26	22.09	23.54	27.76	30.94	36.69	41.46	45.98

SERIES M

MOTORIZED BACKSTOP MODULE

Motorized backstop modules can be fitted between the gear unit and motor. The backstop device incorporates high quality centrifugal lift off sprags which are wear free above the lift off speed (n min).

To ensure correct operation motor speed must exceed lift off speed.

Suitable for ambient temperature -220°F to + 122°F

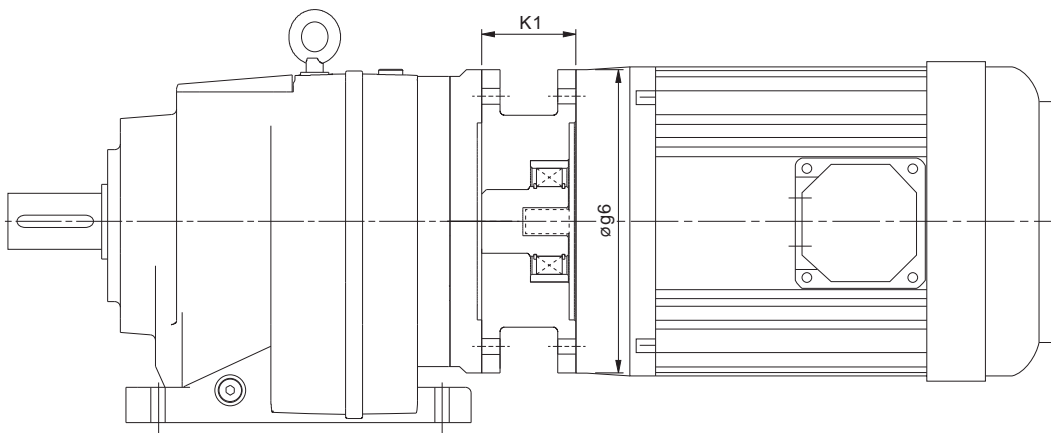

Warning

Removal of motor or backstop will release the drive. Ensure all driven machinery is secure prior to any maintenance work

IEC B5 FLANGE

Motor Frame Size	Lift off Speed ('n' min) (rev/min)	Rated Locking Torque ('T max') (at motor) (lb.in)	øg6	K1
100	670	1505	9.84	2.76
112	670	1505	9.84	2.76
132	620	8319	11.81	3.74
160	620	8319	13.78	5.12
180	620	8319	13.78	5.12
200	550	11151	15.75	5.12

NEMA C FLANGE

Motor Frame Size	Lift off Speed ('n' min) (rev/min)	Rated Locking Torque ('T max') (at motor) (Nm)	øg6	K1
182TC / 184TC	670	2655	8.98	3.75
213TC / 215TC	670	2655	8.98	3.75
254TC / 256TC	620	8319	8.98	4.75
284TC / 286TC	620	8319	11.02	5.37
324TC / 326TC	550	11151	12.99	6.00

When a backstop module is fitted dimension K1 should be added to the overall length of the geared motor assembly.

Rotation of outputshaft must be specified when ordering as viewed from the outputshaft end (as shown in the diagram) see page 28 for column 20 entry

CW	-	Free Rotation	-	Clockwise
		Locked	-	Anticlockwise
AC	-	Free Rotation	-	Anticlockwise
		Locked	-	Clockwise

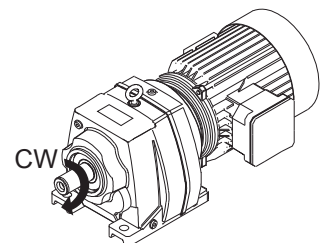

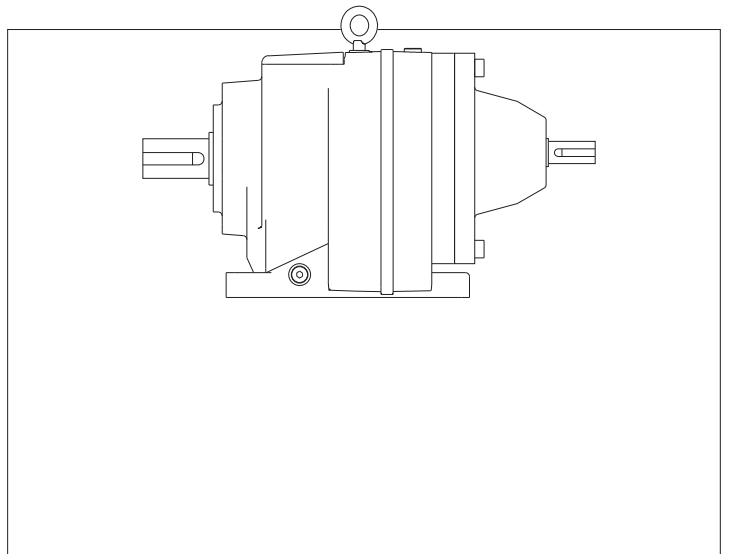

REDUCER

SERIES M

SERIES M

OVERHUNG & AXIAL LOADS (lbf) ON SHAFTS

Maximum permissible overhung loads

When a sprocket, gear etc. is mounted on the shaft a calculation, as below, must be made to determine the overhung load on the shaft, and the results compared to the maximum permissible overhung loads tabulated. Overhung loads can be reduced by increasing the diameter of the sprocket, gear, etc. If the maximum permissible overhung load is exceeded, the sprocket, gear, etc. should be mounted on a separate shaft, flexibly coupled and supported in its own bearings, or the gear unit shaft should be extended to run in an outboard bearing. Alternatively, a larger gear is often a less expensive solution.

Permissible overhung loads vary according to the direction of rotation. The values tabulated are for the most unfavourable direction with the unit transmitting full rated power and the load P applied midway along the shaft extension. Hence they can sometimes be increased for a more favourable direction of rotation, or if the power transmitted is less than the rated capacity of the gear unit, or if the load is applied nearer to the gear unit case. Refer to Application Engineering for further details. In any event, the sprocket, gear etc. should be positioned as close as possible to the gear unit case in order to reduce bearing loads and shaft stresses, and to prolong life.

All units will accept 100% momentary overload on stated capacities.

Overhung load (lbf)

$$P = \frac{HP \times 126,000 \times K}{N \times D}$$

Where

- P = equivalent overhung load (lbf)
- HP = power transmitted by the shaft (Horse Power)
- N = speed of shaft (rev/min)
- R = pitch radius of sprocket, etc. (inches)
- K = factor

Note: 1 lbf = 4.4484 Newtons.

Overhung member K (factor)

Chain sprocket*	1.00
Spur or helical pinion	1.25
Vee belt sheave	1.50
Flat belt pulley	2.00

* If multistrand chain drives are equally loaded and the outer strand is further than dimension A output or B input, refer to Application Engineering.

Distance Midway Along The Shaft Extension

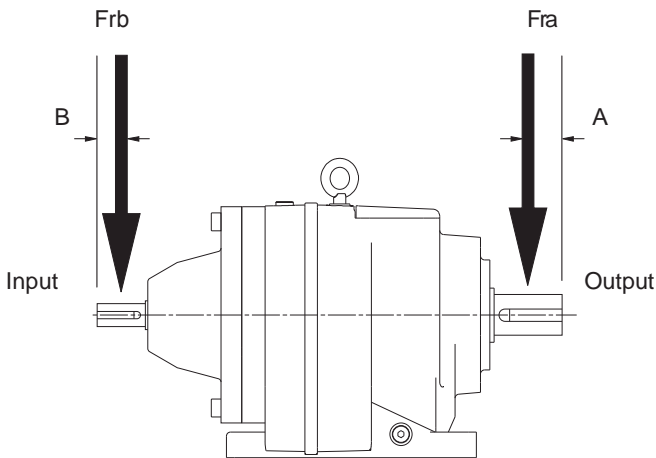

Inputshaft Overhung Loads, Frb (lbf) 1750 rpm

Two, Three, Four and Five Stage Units

	M01	M02	M03	M04	M05	M06	M07	M08	M09	M10	M13	M14
2 Stage	315	345	325	250	230	190	345	315	315	535	1365	1490
3 Stage	345	365	365	315	315	315	380	470	785	880	2500	2500
4 Stage	-	-	315	315	315	315	315	365	365	470	470	470
5 Stage	-	-	315	315	315	315	315	365	365	470	470	470

For output overhung load Fra consult ratings tables pages 31 to 60

Axial Thrust Capacities (Newtons)

No check or calculation is required for axial loads (F_A) towards or away from the unit up to 50% of the permissible overhung load. If the axial thrust considerably exceeds these values or if there is a combination of axial thrust loads and overhung loads please contact Application Engineering.

Size of Unit	No Of Reductions	Dimension A (Inches)	Dimension B (Inches)
M01	2 - 3	0.7875	0.785
M02	2 - 3	0.9845	0.785
M03	2 - 5	0.9845	0.785
M04	2 - 5	1.181	0.785
M05	2 - 5	1.378	0.785
M06	2 - 5	1.378	0.785
M07	2	1.575	0.985
	3	1.575	0.785
	4 - 5	1.575	0.785
M08	2	1.9685	1.18
	3	1.9685	0.985
	4 - 5	1.9685	0.785
M09	2	2.36	1.575
	3	2.36	1.18
	4 - 5	2.36	0.785
M10	2	2.755	2.165
	3	2.755	2.165
	4 - 5	2.755	0.985
M13	2	3.345	2.165
	3	3.345	0.985
	4 - 5	3.345	0.785
M14	2	4.135	2.165
	3	4.135	0.985
	4 - 5	4.135	0.785

SERIES M

DOUBLE REDUCTION RATINGS

SIZES M01 - M04

Note: Input Power, Pm may exceed thermal limit,
Check thermal power page 83

Pm - Input Power (HP)
M2 - Output Torque (lb.in)
i - Exact Ratio (:1)
N2 - Output Speed (rpm)
fra - Overhung Load (lbf)

Column Entry			Input Speed N1 (rpm)	M0122					M0222					M0322					M0422				
				N2 (rpm)	i (:1)	M2 (lb.in)	Pm (HP)	fra (lbf)	N2 (rpm)	i (:1)	M2 (lb.in)	Pm (HP)	fra (lbf)	N2 (rpm)	i (:1)	M2 (lb.in)	Pm (HP)	fra (lbf)	N2 (rpm)	i (:1)	M2 (lb.in)	Pm (HP)	fra (lbf)
3	.	6	3500	933	3.8	391	6.04	250.00	975	3.6	660	10.70	630.00	975	3.6	803	12.90	530.00	976	3.6	1340	21.60	780.00
			1750	466		493	3.78	253.00	487		833	6.67	678.00	487		991	7.93	562.00	488		1690	13.50	825.00
			1160	309		566	2.87	270.00	323		956	5.06	684.00	323		1120	5.94	562.00	323		1930	10.20	863.00
5	.	0	875	233	5.1	622	2.38	270.00	243	5.0	1050	4.19	680.00	243	5.0	1220	4.87	560.00	244	5.0	2130	8.47	900.00
			3500	690		445	5.09	250.00	695		763	8.77	630.00	695		919	10.50	520.00	694		1560	17.90	800.00
			1750	345		562	3.19	261.00	347		963	5.49	660.00	347		1130	6.45	535.00	347		1970	11.20	843.00
5	.	6	1160	228	5.8	645	2.42	278.00	230	5.5	1110	4.17	666.00	230	5.5	1280	4.83	536.00	230	5.6	2260	8.51	903.00
			875	172		679	1.92	290.00	173		1180	3.35	680.00	173		1400	3.96	540.00	173		2490	7.04	950.00
			3500	607		471	4.72	250.00	630		794	8.28	630.00	630		953	9.91	510.00	619		1640	16.80	810.00
6	.	3	1750	303	6.5	594	2.96	265.00	315	6.3	1000	5.19	656.00	315	6.3	1170	6.07	529.00	309	6.3	2070	10.50	855.00
			1160	201		671	2.22	283.00	209		1150	3.94	661.00	209		1330	4.55	529.00	205		2380	7.97	917.00
			875	151		701	1.74	300.00	157		1200	3.10	680.00	157		1450	3.73	529.00	154		2570	6.48	950.00
8	.	0	3500	536	8.3	494	4.37	250.00	555	8.0	837	7.68	630.00	555	8.0	1000	9.16	510.00	551	8.1	1730	15.70	820.00
			1750	268		623	2.74	269.00	277		1060	4.81	651.00	277		1230	5.61	521.00	275		2180	9.83	870.00
			1160	177		689	2.01	291.00	184		1190	3.58	671.00	184		1400	4.20	517.00	182		2500	7.46	932.00
9	.	6	875	134	9.0	720	1.58	320.00	138	9.1	1240	2.82	690.00	138	9.1	1520	3.45	520.00	137	9.1	2640	5.94	960.00
			3500	419		545	3.77	250.00	437		921	6.64	640.00	437		1090	7.86	490.00	434		1900	13.60	830.00
			1750	209		683	2.35	277.00	218		1160	4.16	640.00	218		1340	4.82	505.00	217		2400	8.53	900.00
1	1	.	1160	138	11.4	727	1.66	317.00	145	11.2	1250	2.96	697.00	145	11.2	1520	3.61	496.00	144	10.9	2670	6.28	975.00
			875	104		768	1.32	350.00	109		1310	2.35	760.00	109		1660	2.96	500.00	108		2790	4.94	1020.00
			3500	389		560	3.59	260.00	385		965	6.13	640.00	385		1140	7.22	480.00	383		2000	12.60	840.00
1	2	.	875	97	12.9	692	2.21	281.00	192	12.4	1200	3.79	647.00	192	12.4	1400	4.43	498.00	191	12.5	2520	7.91	916.00
			1160	128		737	1.56	327.00	127		1280	2.67	736.00	127		1590	3.32	509.00	127		2740	5.69	1000.00
			875	77		782	1.25	350.00	96		1350	2.13	820.00	96		1730	2.72	520.00	95		2870	4.49	1100.00
1	4	.	3500	308	14.7	612	3.11	270.00	313	14.1	1040	5.37	645.00	313	14.1	1220	6.29	460.00	321	14.6	2140	11.30	860.00
			1750	154		724	1.83	301.00	156		1250	3.21	674.00	156		1500	3.86	487.00	160		2670	7.02	944.00
			1160	102		782	1.31	357.00	104		1340	2.28	798.00	104		1700	2.89	535.00	106		2840	4.95	1050.00
1	6	.	875	77	16.4	794	1.00	360.00	78	16.0	1410	1.82	840.00	78	16.0	1850	2.37	570.00	80	16.3	2990	3.93	1160.00
			3500	271		641	2.87	270.00	282		1080	5.04	645.00	282		1260	5.88	460.00	279		2260	10.40	880.00
			1750	135		742	1.66	317.00	141		1270	2.95	690.00	141		1560	3.61	482.00	139		2750	6.28	973.00
2	0	.	1160	90	17.6	794	1.17	349.00	93	17.4	1380	2.11	828.00	93	17.4	1760	2.70	545.00	92	17.4	2940	4.45	1100.00
			875	67		794	0.88	350.00	70		1410	1.64	870.00	70		1850	2.14	630.00	69		2990	3.41	1220.00
			3500	237		673	2.64	280.00	249		1130	4.65	650.00	249		1320	5.40	480.00	240		2390	9.44	900.00
2	2	.	1750	118	18.1	763	1.49	334.00	124	18.1	1300	2.66	731.00	124	18.1	1620	3.31	496.00	120	18.1	2830	5.56	1010.00
			1160	78		794	1.03	349.00	82		1410	1.91	871.00	82		1840	2.48	561.00	79		2990	3.89	1170.00
			875	59		794	0.78	350.00	62		1410	1.44	899.00	62		1850	1.88	630.00	60		2990	2.93	1340.00
2	8	.	3500	213	19.9	697	2.46	290.00	219	20.2	1200	4.35	650.00	219	20.2	1390	5.01	480.00	214	20.6	2530	8.92	910.00
			1750	106		783	1.38	348.00	109		1360	2.45	756.00	109		1720	3.09	494.00	107		2930	5.15	1030.00
			1160	70		794	0.93	349.00	72		1410	1.69	899.00	72		1850	2.20	626.00	71		2990	3.48	1230.00
2	8	.	875	53	22.0	794	0.70	350.00	54	22.0	1410	1.27	899.00	54	22.0	1850	1.66	626.00	53	22.0	2990	2.63	1420.00
			3500	193		710	2.27	300.00	199		1220	3.99	650.00	199		1420	4.64	510.00	201		2550	8.44	930.00
			1750	96		794	1.27	349.00	99		1370	2.24	799.00	99		1740	2.85	525.00	100		2920	4.81	1070.00
3	0	.	1160	64	26.4	794	0.84	349.00	65	26.4	1410	1.53	899.00	65	26.4	1850	2.00	680.00	66	27.3	2990	3.26	1270.00
			875	48		794	0.63	350.00	49		1410	1.15	899.00	49		1850	1.51	680.00	50		2990	2.46	1510.00
			3500	176		721	2.10	310.00	173		1250	3.56	670.00	173		1480	4.22	520.00	169		2710	7.57	990.00
3	2	.	1750	88	31.7	794	1.15	349.00	86	31.7	1410	2.01	844.00	86	31.7	1830	2.59	542.00	84	32.2	2990	4.16	1140.00
			1160	58		794	0.76	349.00	57		1410	1.33	899.00	57		1850	1.74	680.00	56		2990	2.76	1370.00
			875	44		794	0.58	349.00	43		1410	1.00	899.00	43		1850	1.31	680.00	42		2990	2.08	1600.00
3	6	.	3500	150	35.7	742	1.84	320.00	159	35.7	1270	3.33	690.00	159	35.7	1520	3.99	530.00	159	35.7	2740	7.17	1010.00
			1750	75		794	0.98	349.00	79		1410	1.85	892.00	79		1850	2.42	573.00	79		2990	3.90	1170.00
			1160	49		794	0.65	349.00	52		1410	1.23	899.00	52		1850	1.60	680.00	52		2990	2.58	1400.00
4	5	.	875	37	41.5	794	0.49	349.00	39	41.5	1410	0.92	899.00	39	41.5	1850	1.21	680.00	39	43.2	2990	1.95	1600.00
			3500	125		767	1.59	349.00	132		1310	2.86	760.00	132		1610	3.53	530.00	128		2850	6.01	1100.00
			1750	62		794	0.82	349.00	66		1410	1.54	899.00	66		1850	2.02	680.00	64		2990	3.15	1290.00
5	0	.	1160	41	47.1	794	0.54	349.00	43	47.1	1410	1.02	899.00	43	47.1	1850	1.34	680.00	42	48.2	2990	2.08	1540.00
			875	31		794	0.41	349.00	33		1410	0.77	899.00	33		1850	1.01	680.00	32		2990	1.57	1600.00
			3500	107		791	1.41	349.00	110		1360	2.48	860.00	110		1710	3.12	550.00	108		2930	5.25	1160.00
5	6	.	1750	53	53.5	794	0.71	349.00	55	53.													

SERIES M

DOUBLE REDUCTION RATINGS SIZES M05 - M08

Note: Input Power, Pm may exceed thermal limit,
Check thermal power page 83

Pm - Input Power (HP)
M2 - Output Torque (lb.in)
i - Exact Ratio (:1)
N2 - Output Speed (rpm)
fra - Overhung Load (lbf)

Column Entry	Input Speed N1 (rpm)	M0522					M0622					M0722					M0822							
		N2 (rpm)	i (:1)	M2 (lb.in)	Pm (HP)	fra (lbf)	N2 (rpm)	i (:1)	M2 (lb.in)	Pm (HP)	fra (lbf)	N2 (rpm)	i (:1)	M2 (lb.in)	Pm (HP)	fra (lbf)	N2 (rpm)	i (:1)	M2 (lb.in)	Pm (HP)	fra (lbf)			
3 . . 6	3500	976		2190	35.1	550								951		2690	42.3	977	951		4160	65.7	1840	
	1750	488	3.585	2590	20.6	561								475	3.678	2700	21.2	1390	475	3.678	4190	32.9	2670	
	1160	323		2590	13.7	687								315		2710	14	1540	315		4200	21.8	2920	
5 . . 0	3500	694		2630	30	220	788							237		2710	10.6	1670	237		4210	16.4	2920	
	1750	347	5.04	3340	18.9	266	394	4.438	3200	20.6	1460	343	5.094	3760	21.2	1060	335	5.214	5930	65.7	1840	5930	65.7	1840
	1160	230		3380	12.7	404	261		3210	13.7	1620	227		3760	14	1270	222		5980	21.8	2830	5980	21.8	2830
5 . . 6	3500	619		2790	28.3	200	560		3260	30	1160	611		3770	10.6	1370	167		5980	16.4	2830	5980	16.4	2830
	1750	309	5.649	3530	17.8	209	280	6.24	4130	18.9	1160	305	5.722	3710	37.4	650	604		6570	65.4	1840	6570	65.4	1840
	1160	205		3650	12.2	313	185		4190	12.7	1400	202		4230	14	1140	200		6640	32.9	2330	6640	32.9	2330
6 . . 3	3500	551		2940	26.6	170	500		3450	28.3	1100	556		3860	35.4	560	543		6900	16.7	1840	6900	16.7	1840
	1750	275	6.341	3650	16.5	187	250	6.994	4370	17.8	1110	278	6.292	4640	21.2	797	271	6.442	7380	32.9	2120	7380	32.9	2120
	1160	182		3660	10.9	358	165		4520	12.2	1310	184		4650	14	1020	180		7390	21.8	2510	7390	21.8	2510
8 . . 0	3500	434		3250	23.1	112	445		3640	26.6	1100	425		4320	30.2	550	420		7680	53.1	1140	7680	53.1	1140
	1750	217	8.053	3980	14.1	114	222	7.851	4530	16.5	1100	212	8.218	5440	19	605	210	8.33	9560	32.9	1560	9560	32.9	1560
	1160	144		3980	9.35	294	147		4530	10.9	1380	141		6080	14	572	139		9570	21.8	1970	9570	21.8	1970
9 . . 0	3500	383		3400	21.4	150	351		4020	23.1	970	374		4540	28	550	374		8020	49.4	1180	8020	49.4	1180
	1750	191	9.129	3980	12.5	167	175	9.97	5080	14.6	971	187	9.344	5730	17.6	556	187	9.352	10200	31.1	1450	10200	31.1	1450
	1160	127		3980	8.25	351	116		5260	9.97	1170	124		6390	13	518	124		10700	21.8	1660	10700	21.8	1660
1 1 . .	3500	321		3610	19	220	309		4210	21.4	965	308		4890	24.8	460	305		8590	43.1	1140	8590	43.1	1140
	1750	160	10.89	3980	10.4	244	154	11.3	5280	13.3	966	154	11.35	6170	15.6	482	152	11.47	10900	27.2	1390	10900	27.2	1390
	1160	106		3980	6.92	478	102		5380	9	1250	102		6650	11.1	567	101		12500	20.6	1240	12500	20.6	1240
1 2 . .	3500	279		3760	17.2	380	259		4470	19	1010	280		5080	23.4	450	270		8820	39.3	1140	8820	39.3	1140
	1750	139	12.54	3770	8.6	419	129	13.48	5340	11.3	1050	140	12.48	6360	14.6	456	135	12.92	11200	24.7	1410	11200	24.7	1410
	1160	92		3770	5.7	698	86		5530	7.76	1390	92		6780	10.3	610	89		12800	18.8	1250	12800	18.8	1250
1 4 . .	3500	240		3920	15.4	360	225		4660	17.2	1020	244		5360	21.5	460	232		9280	35.5	1140	9280	35.5	1140
	1750	120	14.58	3980	7.81	387	112	15.52	4670	8.6	1510	122	14.34	6550	13.1	463	116	15.04	11700	22.4	1360	11700	22.4	1360
	1160	79		3980	5.17	714	74		4670	5.7	1620	80		6990	9.25	668	77		13500	17	1290	13500	17	1290
1 6 . .	3500	214		3980	14	440	193		4850	15.4	1020	215		5680	20.1	450	209		9540	32.9	1140	9540	32.9	1140
	1750	107	16.31	3980	6.99	472	96	18.05	5280	8.36	1370	107	16.26	6790	12	456	104	16.69	12100	20.7	1350	12100	20.7	1350
	1160	71		3980	4.63	811	64		5280	5.54	1620	71		7110	8.31	758	69		12600	14.3	1810	12600	14.3	1810
1 8 . .	3500	201		3980	3.49	1010	48		5280	4.18	1620	53		7300	6.44	1000	52		12600	10.8	1810	12600	10.8	1810
	1750	100	17.39	3980	6.55	522	86	20.2	5540	7.85	1380	97	17.94	6830	10.9	539	95	18.26	12100	18.9	1460	12100	18.9	1460
	1160	66		3980	4.34	867	57		5540	5.2	1620	64		7170	7.6	841	63		12100	12.5	2180	12100	12.5	2180
2 0 . .	3500	169		3980	11.1	640	162		5110	13.6	1010	170		6110	17.1	480	169		9970	27.8	1260	9970	27.8	1260
	1750	84	20.61	3980	5.53	659	81	21.53	5540	7.36	1460	85	20.54	6990	9.76	613	84	20.66	12600	17.5	1440	12600	17.5	1440
	1160	56		3980	3.67	1020	53		5540	4.88	1620	56		7270	6.72	962	56		12900	11.9	2110	12900	11.9	2110
2 2 . .	3500	159		3980	10.4	700	137		5240	11.8	1080	150		6390	15.8	450	150		10200	25.2	1340	10200	25.2	1340
	1750	79	22	3980	5.18	714	68	25.51	5540	6.22	1620	75	23.23	7070	8.74	712	75	23.32	12900	15.9	1560	12900	15.9	1560
	1160	52		3980	3.43	1080	45		5540	4.12	1620	49		7360	6.02	1080	49		13600	11.1	2120	13600	11.1	2120
2 8 . .	3500	128		3980	8.38	840	128		5300	11.2	1160	129		6610	14.1	450	123		10400	21.2	1560	10400	21.2	1560
	1750	64	27.3	3980	4.18	903	64	27.24	5540	5.82	1620	64	26.93	7170	7.65	837	61	28.27	13200	13.4	1830	13200	13.4	1830
	1160	42		3980	2.77	1080	42		5540	3.86	1620	43		7470	5.28	1140	41		14800	9.94	2110	14800	9.94	2110
3 2 . .	3500	108		3980	7.11	910	103		5450	9.26	1240	108		6800	12.2	460	106		10700	18.6	1840	10700	18.6	1840
	1750	54	32.19	3980	3.55	1060	51	33.8	5540	4.7	1620	54	32.12	7290	6.53	994	53	32.97	13500	11.7	2040	13500	11.7	2040
	1160	36		3980	2.35	1080	34		5540	3.11	1620	36		7600	4.51	1080	35		15000	8.68	2380	15000	8.68	2380
3 6 . .	3500	99		3980	6.5	920	87		5530	7.98	1360	99		6890	11.3	550	96		10900	17.3	1900	10900	17.3	1900
	1750	49	35.25	3980	3.25	1080	43	39.86	5540	3.99	1620	49	35.17	7360	6.03	1080	48	36.21	13700	10.9	2130	13700	10.9	2130
	1160	32		3980	2.15	1080	29		5540	2.64	1620	32		7670	4.16	1050	32		15000	7.91	2600	15000	7.91	2600
4 5 . .	3500	81		3700	4.95	980	80		5540	1.99	1620	24		7680	3.14	1050	24		15000	5.97	2600	15000	5.97	2600
	1750	40	43.2	3700	2.47	1230	40	43.64	5540	7.3	1450	82		7010	9.59	720	78		11100	14.5	1950	11100	14.5	1950
	1160	26		3820	1.69	1160	26		5540	2.42	1620	27		7680	3.48	1050	26		15000	6.45	3110	15000	6.45	3110
5 0 . .	3500	72		3350	4.02	1060	65		4590	4.95	1600	72												

SERIES M

DOUBLE REDUCTION RATINGS

SIZES M09 - M14

Note: Input Power, Pm may exceed thermal limit,
Check thermal power page 83

Pm - Input Power (HP)
M2 - Output Torque (lb.in)
i - Exact Ratio (:1)
N2 - Output Speed (rpm)
fra - Overhung Load (lbf)

Column Entry			Input Speed N1 (rpm)	M0921					M1021					M1321					M1421							
				N2 (rpm)	i (:1)	M2 (lb.in)	Pm (HP)	fra (lbf)	N2 (rpm)	i (:1)	M2 (lb.in)	Pm (HP)	fra (lbf)	N2 (rpm)	i (:1)	M2 (lb.in)	Pm (HP)	fra (lbf)	N2 (rpm)	i (:1)	M2 (lb.in)	Pm (HP)	fra (lbf)			
1	.	4	3500	2366		3750	146	2290	2426		6350	253	2790													
			1750	1183	1.479	4770	92.1	2570	1213	1.442	6390	127	3460													
			1160	784		5480	70	2950	804		6390	83.9	4030													
1	.	8	875	591		6040	58	2950	606		6390	63.3	4030													
			3500	1718		4430	125	2290	1737		8780	249	2790													
			1750	859	2.036	5620	78.7	2840	868	2.015	8940	127	3750													
2	.	2	1160	569		6460	59.8	3260	575		8950	83.9	4390													
			875	429		7110	49.6	3260	434		8960	63.3	4390													
			3500	1533		4690	118	2290	1597		9150	238	2790													
2	.	5	1750	766	2.282	5940	74.3	2940	798	2.191	9730	127	3820													
			1160	508		6840	56.4	3370	529		9740	83.9	4480													
			875	383		7520	46.8	3370	399		9750	63.3	4480													
2	.	8	3500	1366		4950	111	2290	1406		9710	223	2790													
			1750	683	2.562	6270	69.8	3050	703	2.489	11100	127	3920													
			1160	452		7220	53.1	3500	466		11100	83.9	4610													
2	.	2	875	341		7940	44	3500	351		11100	63.3	4610													
			3500	1178		7530	146	2290	1169		13200	253	2790	1205		15400	304	5400	1212		22300	443	8100			
			1750	589	2.969	9570	92.1	2770	584	2.992	13200	127	4210	602	2.904	15400	152	7810	606	2.888	22300	222	10100			
3	.	2	1160	390		11000	70	3100	387		13200	83.9	4940	399		15400	101	8930	401		22300	147	11500			
			875	294		12100	58	3100	292		13200	63.3	4940	301		15400	75.9	8390	303		22300	111	11500			
			3500	1060		5570	96.6	2290	1079		10800	191	2790	1097		16900	304	5400	1077		25100	443	8100			
3	.	6	1750	530	3.301	7060	60.9	3300	539	3.242	13700	120	3940	548	3.189	16900	152	7990	538	3.247	25100	222	10300			
			1160	351		8120	46.3	3600	357		13900	80.7	4910	363		16900	101	9130	357		25100	147	11800			
			875	265		8930	38.4	3600	269		13900	60.8	4910	274		16900	75.9	9130	269		25100	111	11800			
3	.	6	3500	948		5740	89.1	2290	1000		11000	180	2790	961		19200	304	5400	915		29400	443	8100			
			1750	474	3.688	7280	56.2	3430	500	3.5	13900	113	4100	480	3.638	19200	152	8250	457	3.822	29500	222	10700			
			1160	314		8360	42.7	3620	331		13900	74.7	5030	318		19300	101	9380	303		29500	147	12200			
4	.	0	875	237		9200	35.4	3620	250		13900	56.3	5030	240		19300	75.9	9380	228		29500	111	12200			
			3500	856		8880	125	2290	837		17800	244	2790	869		21400	304	5400	868		31200	443	8100			
			1750	428	4.088	11300	78.7	2890	418	4.179	18500	127	4140	434	4.025	21400	152	8430	434	4.029	31200	222	10900			
4	.	5	1160	283		12900	59.8	2840	277		18500	83.9	5040	288		21400	101	9430	287		31200	147	12300			
			875	214		14200	49.6	2840	209		18500	63.3	5040	217		21400	75.9	9430	217		31200	111	12300			
			3500	763		9410	118	2290	770		18400	232	2790	791		23500	304	5400	771		35100	443	8100			
5	.	0	1750	381	4.582	11900	74.3	2850	385	4.545	20100	127	3960	395	4.421	23500	152	8540	385	4.537	35100	222	11200			
			1160	253		13700	56.4	2730	255		20100	83.9	4720	262		23500	101	9380	255		35200	147	12400			
			875	190		15100	46.8	2730	192		20200	63.3	4720	197		23500	75.9	9380	192		35100	111	12400			
5	.	6	3500	689		11000	125	2290	708		18900	220	2790	694		26600	304	5400	656		41100	443	8100			
			1750	344	5.073	14000	78.7	2550	354	4.938	21800	127	3920	347	5.042	26700	152	8660	328	5.333	41200	222	11300			
			1160	228		16000	59.8	2400	234		21900	83.9	4560	230		26700	101	9320	217		41200	147	12200			
6	.	3	875	172		17700	49.6	2400	177		21900	63.3	4560	173		26700	75.9	9320	164		41200	111	12200			
			3500	615		11700	118	2290	651		19600	209	2790	631		29300	304	5400	582		46300	443	8100			
			1750	307	5.686	14800	74.3	2430	325	5.37	23800	127	3530	315	5.538	29400	152	8530	291	6.005	46400	222	11000			
6	.	6	1160	204		17000	56.4	2300	215		23800	83.9	4180	209		29400	101	9210	193		46400	147	12000			
			875	153		18700	46.8	2300	162		23800	63.3	4180	157		29400	75.9	9210	145		46400	111	12000			
			3500	528		11200	96.6	2290	520		21300	182	2790	563		33000	304	5400	534		50700	443	8100			
7	.	1	1750	264	6.628	14100	60.9	2550	260	6.724	26300	112	2990	281	6.21	33000	152	8260	267	6.548	50700	222	11100			
			1160	175		16300	46.3	2490	172		29700	83.6	2820	186		33000	101	9020	177		50700	147	12200			
			875	132		17900	38.4	2490	130		29900	63.3	2820	140		33100	75.9	9020	133		50700	111	12200			
7	.	0	3500	472		11500	89.1	2290	482		21900	173	2790	508		36600	304	5400	481		55500	437	8100			
			1750	236	7.404	14600	56.2	2540	241	7.26	27000	106	2900	254	6.879	36600	152	8040	240	7.27	56300	222	10800			
			1160	156		16700	42.7	2520	159		30600	79.7	2760	168		36600	101	8880	159		56300	147	11900			
8	.	0	875	118		18400	35.4	2520	120		32200	63.3	2760	127		36600	75.9	8880	120		56300	111	11900			
			3500	425		13900	96.6	2290	440		22600	163	2790	449		41200	304	5400	403		67000	443	8100			
			1750	212	8.224	17400	60.5	2110	220	7.945	27800	100	3060	224	7.779	41200	152	7830	201	8.667	67000	222	9620			
9	.	0	1160	141		19700	45.3	2100	145		31500	75.1	2990	149		41200	101	8770	133		67000	147	11000			
			875	106		21500	37.1	2100	110		34300	61.6	2990	112		41300	75.9	8770	100		67000	111	11000			
			3500	380		14300	89.1	2290	408		23200	155	2790	406		42700	284	5500	363		73300	437	8100			
1	0	.	1750	190	9.188	18100	56.2	2100	204	8.578	28600	95.5	2980	203	8.618	45700	152	7530	181	9.623	74400	222	9080			
			1160	126		20500	42.2	2050	135		32400															

SERIES M

DOUBLE REDUCTION RATINGS

SIZES M09 - M14

Note: Input Power, Pm may exceed thermal limit,
Check thermal power page 83

Pm - Input Power (HP)
M2 - Output Torque (lb.in)
i - Exact Ratio (:1)
N2 - Output Speed (rpm)
fra - Overhung Load (lbf)

Column Entry			M0921					M1021					M1321					M1421					
			N2	i	M2	Pm	fra	N2	i	M2	Pm	fra	N2	i	M2	Pm	fra	N2	i	M2	Pm	fra	
6	7	8	(rpm)	(:1)	(lb.in)	(HP)	(lbf)	(rpm)	(:1)	(lb.in)	(HP)	(lbf)	(rpm)	(:1)	(lb.in)	(HP)	(lbf)	(rpm)	(:1)	(lb.in)	(HP)	(lbf)	
1	2	.	3500	274		16000	72	1990	279		26400	121	2700	282		44900	208	6970	262		80500	347	8170
			1750	137	12.74	20200	45.3	1990	139	12.51	32500	74.3	2810	141	12.39	55300	128	7330	131	13.32	90500	195	8280
			1160	91		22900	34	1930	92		36800	55.7	2710	93		56200	86.2	8350	87		90500	129	9850
			875	68		24900	27.9	1930	69		39100	44.6	2710	70		56200	65	8350	65		90500	97.5	9850
1	4	.	3500	240		16600	65.5	1930	247		27500	112	2700	249		49200	201	6970	231		83400	317	8360
			1750	120	14.53	21000	41.3	1990	123	14.16	33900	68.5	2740	124	14.03	55700	114	7620	115	15.13	91900	174	8590
			1160	79		23900	31.1	1890	81		38400	51.3	2620	82		55700	75.4	8760	76		91900	116	10200
			875	60		25300	24.8	1890	61		39100	39.4	2620	62		55700	56.8	8760	57		91900	87.2	10200
1	6	.	3500	210		14500	50	1890	213		28900	101	2760	219		50800	182	6970	213		68500	240	8360
			1750	105	16.59	18300	31.5	2700	106	16.43	33400	58.1	2990	109	15.97	54900	98.4	7910	106	16.43	90300	158	9720
			1160	69		21000	24	2780	70		33400	38.5	4100	72		54900	65.2	9080	70		98200	114	10400
			875	52		23100	19.9	2780	53		33400	29	4100	54		54900	49.2	9080	53		98200	85.8	10400
1	8	.	3500	189		14700	45.5	2430	191		29300	91.9	2710	194		54800	175	7550	193		70700	225	9000
			1750	94	18.43	18500	28.7	2820	95	18.25	33400	52.3	3260	97	18	54900	87.3	8250	96	18.11	93300	148	9620
			1160	62		21300	21.8	3040	63		33400	34.7	4550	64		54900	57.8	9570	64		98200	103	10900
			875	47		23400	18.1	3040	47		33400	26.1	4550	48		54900	43.6	9570	48		98200	77.8	10900
2	0	.	3500	169		18000	50	2100	180		30500	90.2	2400	174		50000	144	7600	160		90500	240	9220
			1750	84	20.59	22700	31.5	2110	90	19.41	37600	55.4	2580	87	20	56200	80.8	8540	80	21.75	93800	124	9780
			1160	56		25300	23.2	2570	59		39100	38.2	3580	57		56200	53.5	10100	53		93800	82.2	12000
			875	42		25300	17.5	2570	45		39100	28.8	3580	43		56200	40.4	10100	40		93800	62	12000
2	2	.	3500	153		18200	45.5	2200	162		31600	84	2400	155		53600	137	7650	145		93400	225	9220
			1750	76	22.87	23000	28.7	2290	81	21.57	38900	51.6	2510	77	22.55	56200	71.6	8880	72	23.97	95300	115	9980
			1160	50		25300	20.9	2930	53		39100	34.4	4090	51		56200	47.5	10700	48		95300	75.9	12400
			875	38		25300	15.8	2930	40		39100	25.9	4090	38		56200	35.8	10700	36		95300	57.2	12400
2	5	.	3500	134		15600	34.4	2475	134		31200	68.7	2710	137		54900	124	7700	134		72900	161	9250
			1750	67	26.04	19700	21.6	3310	67	26.03	33400	36.7	4290	68	25.45	54900	62	9260	67	26.07	93400	103	11200
			1160	44		22600	16.5	3790	44		33400	24.3	6290	45		54900	41.1	11300	44		93400	68.4	13900
			875	33		23400	12.8	3790	33		33400	18.4	6290	34		54900	31	11300	33		93400	51.6	13900
2	8	.	3500	121		15800	31.4	2500	116		31700	60.8	2710	123		54900	112	8130	123		74700	152	9250
			1750	60	28.74	19900	19.8	3550	58	29.99	33400	31.9	4950	61	28.35	54900	55.8	9770	61	28.25	88300	90	12200
			1160	40		22900	15.1	4070	38		33400	21.1	7040	40		54900	36.9	11900	41		88300	59.6	15000
			875	30		23400	11.6	4070	29		33400	15.9	7040	30		54900	27.9	11900	30		88300	45	15000
3	2	.	3500	108		19300	34.4	2560	113		35300	65.9	2900	109		55700	101	8450	101		94300	158	9400
			1750	54	32.31	24400	21.6	2960	56	30.76	39100	36.4	3820	54	31.89	56200	50.9	10300	50	34.51	94300	79	12200
			1160	35		25300	14.9	4170	37		39100	24.1	5930	36		56200	33.7	12500	33		94300	52.3	15300
			875	27		25300	11.2	4170	28		39100	18.2	5930	27		56200	25.4	12500	25		94300	39.5	15300
3	6	.	3500	98		19500	31.4	2560	98		36900	59.9	2920	98		56200	91.6	8830	93		95600	148	9680
			1750	49	35.67	24700	19.8	3210	49	35.44	39100	31.6	4510	49	35.52	56200	45.8	10900	46	37.39	95600	73.8	12700
			1160	32		25300	13.4	4560	32		39100	21	6730	32		56200	30.3	13100	31		95600	48.9	15700
			875	24		25300	10.1	4560	24		39100	15.8	6730	24		56200	22.9	13100	23		95600	36.9	15700
4	0	.	3500	86		21800	31.2	2600	94		36800	57.1	2960	89		52500	78	9210	88		82100	121	9810
			1750	43	40.25	21800	15.6	4570	47	37.06	36800	28.6	5630	44	39.01	56700	42.1	10900	44	39.42	86600	63.6	16000
			1160	28		21800	10.3	6140	31		36800	18.9	7870	29		57200	28.1	13100	29		89400	43.6	18900
			875	21		21800	7.9	6140	23		36800	14.3	7870	22		57200	21.2	13100	22		89500	32.9	18900
4	5	.	3500	78		21800	28.2	2800	81		36800	49.6	3310	80		53200	71	9450	81		82600	112	10300
			1750	39	44.44	21800	14.1	4930	40	42.7	36800	24.8	6370	40	43.45	57200	38.2	11400	40	42.71	87200	59.1	16600
			1160	26		21800	9.35	6320	27		36800	16.4	8720	26		57200	25.3	13700	27		89500	40.2	19500
			875	19		21900	7.05	6320	20		36900	12.4	8720	20		57200	19.1	13700	20		89500	30.3	19500
5	0	.	3500	71		20200	23.7	3300	73		37600	45.2	3350	71		50100	59.5	9980	68		71900	81.1	11100
			1750	35	49.07	25300	14.8	4200	36	47.93	37700	22.6	6480	35	48.63	50100	29.7	13200	34	51.27	72000	40.6	17600
			1160	23		25300	9.8	5610	24		37700	15	8930	23		50100	19.7	14600	22		72000	26.9	20500
			875	17		25300	7.39	5610	18		37700	11.3	8930	17		50100	14.9	14600	17		72000	20.3	20500
5	6	.	3500	63		19100	19.9	3530	67		34200	38.3	3600	67		53300	59.5	10120	60		74700	75.2	11700
			1750	31	55.18	18000	9.37	6410	33	51.49	34200	19.2	7810	33	51.74	53300	29.7	13200	30	57.52	74700	37.6	18200
			1160	21		17400	6.02	6420	22		34300	12.7	9620	22		53300	19.7	14600	20		74800	24.9	20500
			875	15		17100	4.46	6420	16		34300	9.59	9620	16		53400	14.9	14600	15		74800	18.8	20500
6	3	.	3500	57		21800	20.6	3825	60		36800	36.8	3800	58									

SERIES M

TRIPLE REDUCTION RATINGS

SIZES M01 - M04

Note: Input Power, Pm may exceed thermal limit,
Check thermal power page 83

Pm - Input Power (HP)
M2 - Output Torque (lb.in)
i - Exact Ratio (:1)
N2 - Output Speed (rpm)
fra - Overhung Load (lbf)

Column Entry			Input Speed N1 (rpm)	M0132					M0232					M0332					M0432				
				N2	i	M2	Pm	fra	N2	i	M2	Pm	fra	N2	i	M2	Pm	fra	N2	i	M2	Pm	fra
6	7	8	(rpm)	(:1)	(lb.in)	(HP)	(lbf)	(rpm)	(:1)	(lb.in)	(HP)	(lbf)	(rpm)	(:1)	(lb.in)	(HP)	(lbf)	(rpm)	(:1)	(lb.in)	(HP)	(lbf)	
			3500	59		794	0.81	349	61		1350	1.39	899	61		1790	1.84	680	59		2440	2.46	1290
5	6	.	1750	29	58.46	795	0.4	349	30	57	1410	0.73	899	30	57	1850	0.95	680	29	58.4	2870	1.43	1620
			1160	19		795	0.27	348	20		1410	0.48	899	20		1850	0.63	680	19		2990	0.99	1610
			875	14		795	0.2	348	15		1410	0.36	899	15		1850	0.47	680	14		2990	0.75	1610
			3500	54		794	0.73	348	55		1380	1.29	899	55		1850	1.72	680	54		2490	2.27	1390
6	3	.	1750	27	64.45	795	0.36	349	27	62.9	1410	0.66	899	27	62.9	1850	0.86	680	27	64.3	2960	1.34	1620
			1160	17		795	0.24	348	18		1410	0.44	899	18		1850	0.57	680	18		2990	0.9	1610
			875	13		795	0.18	348	13		1410	0.33	899	13		1850	0.43	680	13		2990	0.68	1610
			3500	49		794	0.66	348	50		1410	1.19	899	50		1850	1.56	680	47		2570	2.03	1570
7	1	.	1750	24	70.93	795	0.33	349	25	69.2	1410	0.6	899	25	69.2	1850	0.78	680	23	74	2990	1.18	1610
			1160	16		795	0.22	348	16		1410	0.4	899	16		1850	0.52	680	15		2990	0.78	1610
			875	12		795	0.16	348	12		1410	0.3	899	12		1850	0.39	680	11		2990	0.59	1610
			3500	42		794	0.57	348	43		1410	1.02	899	43		1850	1.34	680	43		2620	1.9	1610
8	0	.	1750	21	83.1	795	0.28	348	21	81.1	1410	0.51	899	21	81.1	1850	0.67	680	21	80.4	2990	1.08	1610
			1160	13		795	0.19	348	14		1410	0.34	899	14		1850	0.44	680	14		2990	0.72	1610
			875	10		795	0.14	348	10		1410	0.26	899	10		1850	0.33	680	10		2990	0.64	1610
			3500	35		794	0.47	348	35		1410	0.86	899	35		1850	1.12	680	36		2720	1.65	1610
1	0	0	1750	17	99.7	795	0.24	348	17	97.3	1410	0.43	899	17	97.3	1850	0.56	680	18	96.5	2990	0.9	1610
			1160	11		795	0.16	348	11		1410	0.28	899	11		1850	0.37	680	12		2990	0.6	1610
			875	8		795	0.12	348	8		1410	0.21	899	8		1850	0.28	680	9		2990	0.45	1610
			3500	30		795	0.41	348	30		1410	0.73	899	30		1850	0.96	680	30		2860	1.45	1610
1	1	2	1750	15	116.2	795	0.2	348	15	113	1410	0.37	899	15	113	1850	0.48	680	15	116	2990	0.76	1610
			1160	9		795	0.13	348	10		1410	0.24	899	10		1850	0.32	680	10		2990	0.5	1610
			875	7		795	0.1	348	7		1410	0.18	899	7		1850	0.24	680	7		2990	0.38	1610
			3500	27		795	0.37	348	27		1410	0.66	899	27		1850	0.86	680	26		2980	1.34	1610
1	2	5	1750	13	129.1	795	0.18	348	13	126	1410	0.33	899	13	126	1850	0.43	680	13	131	2990	0.67	1610
			1160	8		795	0.12	348	9		1410	0.22	899	9		1850	0.29	680	8		2990	0.44	1610
			875	6		795	0.09	348	6		1410	0.17	899	6		1850	0.22	680	6		2990	0.34	1610
			3500	22		795	0.3	348	23		1410	0.55	899	23		1850	0.72	680	23		2990	1.15	1610
1	6	0	1750	11	155.5	795	0.15	348	11	152	1410	0.27	899	11	152	1850	0.36	680	11	152	2990	0.58	1610
			1160	7		795	0.1	348	7		1410	0.18	899	7		1850	0.24	680	7		2990	0.38	1610
			875	5		795	0.08	348	5		1410	0.14	899	5		1850	0.18	680	5		2990	0.29	1610
			3500	19		795	0.26	348	20		1410	0.48	899	20		1850	0.62	680	20		2990	1.02	1610
1	8	0	1750	9	178.2	795	0.13	348	10	174	1410	0.24	899	10	174	1850	0.31	680	10	172	2990	0.51	1610
			1160	6		795	0.09	348	6		1410	0.16	899	6		1850	0.21	680	6		2990	0.34	1610
			875	4		795	0.07	348	5		1410	0.12	899	5		1850	0.16	680	5		2990	0.25	1610
			3500	17		795	0.23	348	17		1410	0.42	899	17		1850	0.55	680	17		2990	0.9	1610
2	0	0	1750	8	202.6	795	0.12	348	8	198	1410	0.21	899	8	198	1850	0.28	680	8	196	2990	0.45	1610
			1160	5		795	0.08	348	5		1410	0.14	899	5		1850	0.18	680	5		2990	0.3	1610
			875	4		795	0.06	348	4		1410	0.11	899	4		1850	0.14	680	4		2990	0.22	1610

SERIES M

TRIPLE REDUCTION RATINGS

SIZES M05 - M08

Note: Input Power, Pm may exceed thermal limit,
Check thermal power page 83

Pm - Input Power (HP)
M2 - Output Torque (lb.in)
i - Exact Ratio (:1)
N2 - Output Speed (rpm)
fra - Overhung Load (lbf)

Column Entry			Input Speed N1 (rpm)	M0532					M0632					M0732					M0832															
				N2	i	M2	Pm	fra	N2	i	M2	Pm	fra	N2	i	M2	Pm	fra	N2	i	M2	Pm	fra											
6	7	8	(rpm)	(:1)	(lb.in)	(HP)	(lbf)	(rpm)	(:1)	(lb.in)	(HP)	(lbf)	(rpm)	(:1)	(lb.in)	(HP)	(lbf)	(rpm)	(:1)	(lb.in)	(HP)	(lbf)												
			3500	59		3800	3.8	1060										59		5450	5.41	995	58		10900	10.7	2040							
5	6	.	1750	29	58.38	3980	1.98	1100						29	59	6310	3.11	1630	29	60.3	13400	6.48	3450											
			1160	19		3980	1.31	1100						19		7190	2.35	1260	19		15000	4.8	3250											
			875	14		3980	0.99	1100						14		7680	1.89	1260	14		15000	3.62	3250											
			3500	54		3980	3.35	1080	48		4700	3.8	1620	55		5520	5.14	1080	53		11200	9.98	2040											
6	3	.	1750	27	64.29	3980	1.8	1100	24	72.3	5370	2.16	1620	27	62.8	6400	2.96	1590	26	66	13800	6.08	3540											
			1160	18		3980	1.19	1100	16		5540	1.47	1620	18		7340	2.25	1190	17		15000	4.39	3250											
			875	13		3980	0.9	1100	12		5540	1.11	1620	13		7680	1.77	1190	13		15000	3.31	3250											
			3500	47		3790	2.99	1100	43		4570	3.35	1620	47		5720	4.5	1130	46		11600	9.14	2130											
7	1	.	1750	23	73.95	3980	1.57	1100	21	79.6	5260	1.92	1620	23	74.5	6780	2.65	1430	23	74.7	14300	5.58	3530											
			1160	15		3980	1.04	1100	14		5540	1.34	1620	15		7680	1.99	1050	15		15000	3.88	3250											
			875	11		3980	0.78	1100	10		5540	1.01	1620	11		7680	1.5	1050	11		15000	2.92	3250											
			3500	43		3860	2.8	1100	38		4700	2.99	1620	44		5800	4.27	1130	41		12000	8.39	2470											
8	0	.	1750	21	80.4	3980	1.44	1100	19	91.6	5460	1.73	1620	22	79.5	6920	2.53	1370	20	84.3	14800	5.12	3330											
			1160	14		3980	0.95	1100	12		5540	1.16	1620	14		7680	1.86	1050	13		15000	3.44	3250											
			875	10		3980	0.72	1100	9		5540	0.88	1620	11		7680	1.4	1050	10		15000	2.59	3250											
			3500	36		3980	2.41	1100	35		4780	2.8	1620	35		6070	3.6	1130	34		12700	7.33	2630											
1	0	0	1750	18	96.52	3980	1.2	1100	17	99.5	5540	1.62	1620	17	98.7	7440	2.2	1150	17	102	15000	4.29	3250											
			1160	12		3980	0.8	1100	11		5540	1.07	1620	11		7680	1.5	1050	11		15000	2.84	3250											
			875	9		3980	0.6	1100	8		5540	0.81	1620	8		7680	1.13	1050	8		15000	2.14	3250											
			3500	30		3980	2.01	1100	29		4950	2.42	1620	30		6290	3.16	1050	29		13300	6.58	3250											
1	1	2	1750	15	115.8	3980	1	1100	14	120	5540	1.35	1620	15	116	7680	1.92	1050	14	119	15000	3.68	3250											
			1160	10		3980	0.66	1100	9		5540	0.89	1620	9		7680	1.27	1050	9		15000	2.44	3250											
			875	7		3980	0.5	1100	7		5540	0.67	1620	7		7680	0.96	1050	7		15000	1.84	3250											
			3500	26		3980	1.79	1100	24		5180	2.11	1620	27		6430	2.96	1050	26		13700	6.16	3250											
1	2	5	1750	13	130.5	3980	0.89	1100	12	143	5540	1.13	1620	13	127	7680	1.76	1050	13	131	15000	3.35	3250											
			1160	8		3980	0.59	1100	8		5540	0.75	1620	9		7680	1.16	1050	8		15000	2.22	3250											
			875	6		3980	0.45	1100	6		5540	0.56	1620	6		7680	0.88	1050	6		15000	1.67	3250											
			3500	23		3980	1.53	1100	21		5340	1.93	1620	22		6880	2.58	1050	21		14600	5.33	3250											
1	6	0	1750	11	151.7	3980	0.77	1100	10	162	5540	1	1620	11	156	7680	1.44	1050	10	160	15000	2.73	3250											
			1160	7		3980	0.51	1100	7		5540	0.66	1620	7		7680	0.95	1050	7		15000	1.81	3250											
			875	5		3980	0.38	1100	5		5540	0.5	1620	5		7830	0.73	1050	5		15000	1.36	3250											
			3500	20		3980	1.35	1100	18		5540	1.72	1620	20		7140	2.4	1050	19		15000	5.01	3250											
1	8	0	1750	10	172.2	3980	0.68	1100	9	188	5540	0.86	1620	10	174	7680	1.29	1050	9	175	15000	2.51	3250											
			1160	6		3980	0.45	1100	6		5540	0.57	1620	6		7680	0.86	1050	6		15000	1.66	3250											
			875	5		3980	0.34	1100	4		5540	0.43	1620	5		7860	0.66	1050	4		15000	1.25	3250											
			3500	17		3980	1.19	1100	16		5540	1.52	1620	17		7410	2.23	1050	17		15000	4.38	3250											
2	0	0	1750	8	195.8	3980	0.6	1100	8	213	5540	0.76	1620	8	195	7680	1.15	1050	8	202	15000	2.18	3250											
			1160	5		3980	0.39	1100	5		5540	0.5	1620	5		7780	0.77	1010	5		15000	1.45	3250											
			875	4		3980	0.3	1100	4		5540	0.38	1620	4		7860	0.59	1050	4		15300	1.11	3250											
			3500						14		5540	1.34	1620																					
2	2	5	1750						7	242	5540	0.67	1620																					
			1160						4		5540	0.44	1620																					
			875						3		5540	0.33	1620																					

SERIES M

TRIPLE REDUCTION RATINGS

SIZES M09 - M14

Note: Input Power, Pm may exceed thermal limit,
Check thermal power page 83

Pm - Input Power (HP)
M2 - Output Torque (lb.in)
i - Exact Ratio (:1)
N2 - Output Speed (rpm)
fra - Overhung Load (lbf)

Column Entry	Input Speed N1 (rpm)	M0932					M1032					M1332					M1432					
		N2 (rpm)	i (:1)	M2 (lb.in)	Pm (HP)	fra (lbf)	N2 (rpm)	i (:1)	M2 (lb.in)	Pm (HP)	fra (lbf)	N2 (rpm)	i (:1)	M2 (lb.in)	Pm (HP)	fra (lbf)	N2 (rpm)	i (:1)	M2 (lb.in)	Pm (HP)	fra (lbf)	
4 0 .	3500																					
	1750										87		35900	52.5	8540	84			62100	87.9	9780	
	1160										43	39.93	46800	34	12400	42	41.36	80300	56.5	15700		
4 5 .	875																					
	3500										29		50800	24.4	14200	28			89700	41.8	17800	
	1750										21		53700	19.5	14500	21			94300	33.1	17800	
5 0 .	875																					
	3500										79		44000	58.5	8880	72			77700	94.6	9980	
	1750										39	44.18	52700	34.8	12400	36	48.21	97300	58.9	14300		
5 6 .	1160																					
	875										19		56200	24.5	14400	24			97300	39	17600	
	3500										69		44700	52.5	9260	63			82000	87.9	11200	
6 3 .	1750																					
	1160										23		56200	21.7	14500	21			97300	51.9	15300	
	875										17		56200	16.3	14500	15			97300	25.9	18700	
7 1 .	3500	58		17600	17.2	2960	58			27800	27.1	3820	61						71600	70.6	12200	
	1750	29	59.85	21600	10.5	5690	29	60.23		33400	16.1	8680	30	56.93					89700	44	17400	
	1160	19		23400	7.49	5780	19			33400	10.7	9620	20						96700	31.4	20200	
8 0 .	875	14		23400	5.64	5780	14			33400	8.02	9620	15						98200	24	20300	
	3500	52		18100	15.9	3210	52			29100	25.4	4510	54						74500	66.6	12700	
	1750	26	66.49	22300	9.73	5920	26	66.93		33400	14.5	9190	27	64.17					91500	40.7	18000	
9 0 .	1160	17		23400	6.75	5780	17			33400	9.59	9620	18						98200	28.9	20300	
	875	13		23400	5.08	5780	13			33400	7.22	9620	13						98200	21.8	20300	
	3500	47		19600	15.5	4570	49			30400	25.1	5630	49						94600	70.6	16000	
1 0 0	1750	23	74.26	24200	9.45	5930	24	71.17		37500	15.3	8880	24	71.32					97300	36.2	18300	
	1160	15		25300	6.54	5610	16			39100	10.6	9350	16						97300	23.9	20300	
	875	11		25300	4.93	5610	12			39100	7.95	9350	12						97300	18.1	20300	
1 1 2	3500	42		20300	14.4	4700	44			31400	23.3	6100	43						97300	65.9	14000	
	1750	21	82.51	24900	8.78	5710	22	79.08		38700	14.2	9230	21	80.39					97300	32.8	19200	
	1160	14		25300	5.89	5610	14			39100	9.5	9350	14						97300	21.7	20300	
1 2 5	875	10		25300	4.44	5610	11			39100	7.16	9350	10						97300	16.4	20300	
	3500	37		20100	12.5	4800	36			32400	19.8	6480	38						85600	53.3	14300	
	1750	18	93.92	23400	7.23	5780	18	95.44		33400	10.2	9620	19	90.75					98200	30.4	20300	
1 4 0	1160	12		23400	4.78	5780	12			33400	6.73	9620	12						98200	20.2	20300	
	875	9		23400	3.6	5780	9			33400	5.07	9620	9						98200	15.2	20300	
	3500	33		20700	11.6	5610	31			33400	17.7	7810	34						88100	50.5	15300	
1 6 0	1750	16	103.7	23400	6.54	5780	15	110		33400	8.83	9620	17	101.1					98200	28.1	20300	
	1160	11		23400	4.33	5780	10			33400	5.84	9620	11						98200	18.6	20300	
	875	8		23400	3.26	5780	7			33400	4.4	9620	8						98200	14	20300	
1 8 0	3500	30		22500	11.3	5610	31			35000	18.1	8500	30						97300	45.9	17500	
	1750	15	116.5	25300	6.31	5610	15	112.8		39100	10.1	9350	15	113.7					97300	22.9	20300	
	1160	9		25300	4.17	5610	10			39100	6.67	9350	10						97300	15.1	20300	
2 0 0	875	7		25300	3.15	5610	7			39100	5.02	9350	7						97300	11.4	20300	
	3500	27		23200	10.5	5610	26			36500	16.4	8680	27						97300	42.3	18300	
	1750	13	128.7	25300	5.71	5610	13	129.9		39100	8.75	9350	13	126.6					97300	21.1	20300	
2 2 5	1160	9		25300	3.78	5610	8			39100	5.79	9350	9						97300	14	20300	
	875	6		25300	2.85	5610	6			39100	4.36	9350	6						97300	10.5	20300	
	3500	24		21800	8.86	5610	25			36800	15.9	8880	25						89500	37.1	19000	
2 5 0	1750	12	145.2	21900	4.4	6320	12	135.9		36900	7.92	9520	12	139.1					89500	18.5	20400	
	1160	7		21900	2.91	6320	8			36900	5.24	9520	8						89500	12.2	20400	
	875	6		21900	2.19	6320	6			36900	3.95	9520	6						89500	9.22	20300	
2 8 0	3500	21		21800	8.01	5610	22			36800	13.8	9250	22						89500	34.2	20400	
	1750	10	160.3	21900	3.98	6320	11	156.6		36900	6.88	9520	11	154.9					89500	17	20400	
	1160	7		21900	2.63	6320	7			36900	4.55	9520	7						89500	11.3	20400	
2 0 0	875	5		21900	1.98	6320	5			36900	3.43	9520	5						89500	8.5	20300	
	3500	19		25300	8.35	5610	19			39100	13	9350	20						97300	30.8	20400	
	1750	9	177	25300	4.16	5610	9	175.7		39100	6.48	9350	10	173.4					97300	15.4	20300	
2 2 5	1160	6		25300	2.75	5610	6			39100	4.29	9350	6						97300	10.2	20300	
	875	4		25300	2.07	5610	4			39100	3.23	9350	5						97300	7.67	20300	
	3500	17		25300	7.44	5610	18			39100	12.1	9350	18						97300	27.5	20400	
2 5 0	1750	8	199	25300	3.71	5610	9	188.8		39100	6.04	9350	9	184.5					97300	13.7	20300	
	1160	5		25300	2.45	5610	6			39100	4	9350	6						97300	9.09	20300	
	875	4		25300	1.85	5610	4			39100	3.02	9350	4						97300	6.85	20300	
2 8 0	3500	15		21900	5.83	5610	16			36900	10.2	9520	16						89500	24.9	20400	
	1750	7	220.5	21900	2.9	6320	8	211.8		36900	5.09	9520	8	212.1					89500	12.4	20400	
	1160	5		21900	1.92	6320	5			36900	3.37</											

SERIES M

QUADRUPE REDUCTION RATINGS

SIZES M08 - M14

Note: Input Power, Pm may exceed thermal limit,
Check thermal power page 83

Pm - Input Power (HP)
M2 - Output Torque (lb.in)
i - Exact Ratio (:1)
N2 - Output Speed (rpm)
fra - Overhung Load (lbf)

Column Entry	Input Speed N1 (rpm)	M0842				M0941				M1041				M1341				M1441										
		N2 (rpm)	i (:1)	M2 (lb.in)	Pm (HP)	fra (lbf)	N2 (rpm)	i (:1)	M2 (lb.in)	Pm (HP)	fra (lbf)	N2 (rpm)	i (:1)	M2 (lb.in)	Pm (HP)	fra (lbf)	N2 (rpm)	i (:1)	M2 (Nm)	Pm (HP)	fra (kN)							
	3500	15.29		12390	3.164	3645	15.14		23364	5.910	6300	15.89		39029	10.356	9000	15.42		56198	14.472	14400	14.18		93810	22.214			
2	2	5	1750	7.645	228.9	12390	1.582	3645	7.572	231.1	23364	2.955	6300	7.944	220.3	39029	5.178	9000	7.709	227	56198	7.236	14400	7.089	246.9	93810	11.107	17775
	1160	5.067		12390	1.049	3645	5.019		23364	1.959	6300	5.265		39029	3.432	9000	5.110		56198	4.796	14400	4.699		93810	7.362	17775		
	875	3.822		12390	0.791	3645	3.786		23364	1.477	6300	3.972		39029	2.589	9000	3.855		56198	3.618	14400	3.544		93810	5.553	17775		
	3500	13.52		13275	2.996	3645	13.56		25311	5.730	6300	14.45		39029	9.418	9000	14.02		56198	13.161	14400	12.89		93810	20.202			
2	5	0	1750	6.757	259	13275	1.498	3645	6.778	258.2	25311	2.865	6300	7.224	242.2	39029	4.709	9000	7.011	249.6	56198	6.581	14400	6.447	271.4	93810	10.101	
	1160	4.479		13275	0.993	3645	4.493		25311	1.899	6300	4.789		39029	3.121	9000	4.647		56198	4.362	14400	4.274		93810	6.696	17775		
	875	3.379		13275	0.749	3645	3.389		25311	1.433	6300	3.612		39029	2.355	9000	3.506		56198	3.290	14400	3.224		93810	5.051	17775		
	3500	11.62		13275	2.576	3645	11.66		25311	4.929	6300	12.58		39029	8.197	9000	12.20		56198	11.454	14400	11.22		93810	17.582			
2	8	0	1750	5.810	301.2	13275	1.288	3645	5.829	300.2	25311	2.464	6300	6.287	278.3	39029	4.098	9000	6.102	286.8	56198	5.727	14400	5.611	311.9	93810	8.791	17775
	1160	3.851		13275	0.854	3645	3.864		25311	1.633	6300	4.168		39029	2.717	9000	4.045		56198	3.796	14400	3.719		93810	5.827	17775		
	875	2.905		13275	0.644	3645	2.915		25311	1.232	6300	3.144		39029	2.049	9000	3.051		56198	2.864	14400	2.805		93810	4.395	17775		
	3500	10.39		13275	2.303	3645	10.42		25311	4.406	6300	11.09		39029	7.229	9000	10.76		56198	10.102	14400	9.90		93810	15.506			
3	0	0	1750	5.193	337	13275	1.151	3645	5.211	335.8	25311	2.203	6300	5.545	315.6	39029	3.614	9000	5.381	325.2	56198	5.051	14400	4.948	353.7	93810	7.753	17775
	1160	3.442		13275	0.763	3645	3.454		25311	1.460	6300	3.675		39029	2.396	9000	3.567		56198	3.348	14400	3.280		93810	5.139	17775		
	875	2.596		13275	0.576	3645	2.606		25311	1.101	6300	2.772		39029	1.807	9000	2.691		56198	2.525	14400	2.474		93810	3.876	17775		
	3500	9.74		13275	2.160	3645	9.78		25311	4.132	6300	10.05		39029	6.552	9000	9.76		56198	9.156	14400	8.97		93810	14.054			
3	6	0	1750	4.872	359.2	13275	1.080	3645	4.887	358.1	25311	2.066	6300	5.026	348.2	39029	3.276	9000	4.877	358.8	56198	4.578	14400	4.485	390.2	93810	7.027	17775
	1160	3.229		13275	0.716	3645	3.240		25311	1.370	6300	3.331		39029	2.171	9000	3.233		56198	3.034	14400	2.973		93810	4.658	17775		
	875	2.436		13275	0.540	3645	2.444		25311	1.033	6300	2.513		39029	1.638	9000	2.439		56198	2.289	14400	2.242		93810	3.513	17775		
	3500	8.22		13275	1.823	3645	8.25		25311	3.487	6300	8.78		39029	5.722	9000	8.52		56198	7.997	14400	7.83		93810	12.275			
4	0	0	1750	4.111	425.7	13275	0.911	3645	4.124	424.4	25311	1.743	6300	4.389	398.7	39029	2.861	9000	4.260	410.8	56198	3.998	14400	3.917	446.7	93810	6.137	17775
	1160	2.725		13275	0.604	3645	2.734		25311	1.156	6300	2.910		39029	1.897	9000	2.824		56198	2.650	14400	2.597		93810	4.068	17775		
	875	2.055		13275	0.456	3645	2.062		25311	0.872	6300	2.195		39029	1.431	9000	2.130		56198	1.999	14400	1.959		93810	3.069	17775		
	3500	7.28		13629	1.658	3645	7.43		25311	3.139	6300	7.90		39029	5.149	9000	7.56		56198	7.092	14400	7.11		95580	11.348	17775		
4	5	0	1750	3.642	480.5	13629	0.829	3645	3.713	471.4	25311	1.570	6300	3.950	443	39029	2.575	9000	3.778	463.2	56198	3.546	14400	3.554	492.3	95580	5.674	17775
	1160	2.414		13629	0.550	3645	2.461		25311	1.040	6300	2.618		39029	1.707	9000	2.504		56198	2.351	14400	2.356		95580	3.761	17775		
	875	1.821		13629	0.415	3645	1.856		25311	0.785	6300	1.975		39029	1.287	9000	1.889		56198	1.773	14400	1.777		95580	2.837	17775		
	3500	6.82		13629	1.553	3645	6.96		25311	2.941	6300	6.99		39029	4.553	9000	6.68		56198	6.271	14400	6.29		95580	10.034			
5	0	0	1750	3.411	513	13629	0.776	3645	3.478	503.1	25311	1.470	6300	3.493	501.1	39029	2.277	9000	3.341	523.8	56198	3.136	14400	3.143	556.8	95580	5.017	17775
	1160	2.261		13629	0.515	3645	2.306		25311	0.975	6300	2.315		39029	1.509	9000	2.214		56198	2.078	14400	2.083		95580	3.326	17775		
	875	1.706		13629	0.388	3645	1.739		25311	0.735	6300	1.746		39029	1.138	9000	1.670		56198	1.568	14400	1.571		95580	2.509	17775		
	3500	5.63		15045	1.414	3645	5.61		25311	2.370	6300	6.03		39029	3.928	9000	5.76		56198	5.410	14400	5.42		95580	8.655	17775		
6	5	0	1750	2.814	621.9	15045	0.707	3645	2.803	624.4	25311	1.185	6300	3.013	580.9	39029	1.964	9000	2.882	607.3	56198	2.705	14400	2.711	645.5	95580	4.328	17775
	1160	1.865		15045	0.469	3645	1.858		25311	0.785	6300	1.997		39029	1.302	9000	1.910		56198	1.793	14400	1.797		95580	2.869	17775		
	875	1.407		15045	0.354	3645	1.401		25311	0.592	6300	1.506		39029	0.982	9000	1.441		56198	1.352	14400	1.356		95580	2.164	17775		
	3500	4.54		15045	1.140	3645	4.75		25311	2.010	6300	5.05		39029	3.293	9000	4.83		56198	4.535	14400	4.55		95580	7.257	17775		
7	3	0	1750	2.288	771.8	15045	0.570	3645	2.377	736.2	25311	1.005	6300	2.526	692.8	39029	1.646	9000	2.416	724.3	56198	2.268	14400	2.273	769.9	95580	3.628	17775
	1160	1.503		15045	0.378	3645	1.576		25311	0.666	6300	1.674		39029	1.091	9000	1.602		56198	1.503	14400	1.507		95580	2.405	17775		
	875	1.134		15045	0.285	3645	1.189		25311	0.502	6300	1.263		39029	0.823	9000	1.208		56198	1.134	14400	1.136		95580	1.814	17775		
	3500	3.89		15045	0.977	3645	3.97		25311	1.677	6300	4.23		39029	2.754	9000	4.08		56198	3.825	14400	4.37		94695	6.905	17775		
8	6	0	1750	1.944	900	15045	0.489	3645	1.984	882.1	25311	0.839	6300	2.113	828.4	39029	1.377	9000	2.038	858.8	56198	1.913	14400	2.183	801.7	94695	3.452	17775
	1160	1.289		15045	0.324	3645	1.315		25311	0.556	6300	1.400		39029	0.913	9000	1.351		56198	1.268	14400	1.447		94695	2.288	17775		
	875	0.972		15045																								

SERIES M

QUINTUPLE REDUCTION RATINGS

SIZES M03 - M07

Note: Input Power, Pm may exceed thermal limit,
Check thermal power page 83

Pm - Input Power (HP)
M2 - Output Torque (lb.in)
i - Exact Ratio (:1)
N2 - Output Speed (rpm)
fra - Overhung Load (lbf)

Column Entry			Input Speed N1 (rpm)	M0352					M0452					M0552					M0652					M0752				
				N2	i	M2	Pm	fra	N2	i	M2	Pm	fra	N2	i	M2	Pm	fra	N2	i	M2	Pm	fra	N2	i	M2	Pm	fra
6	7	8	(rpm)	(:1)	(lb.in)	(HP)	(lbf)	(rpm)	(:1)	(lb.in)	(HP)	(lbf)	(rpm)	(:1)	(lb.in)	(HP)	(lbf)	(rpm)	(:1)	(lb.in)	(HP)	(lbf)	(rpm)	(i)	(Nm)	(HP)	(kN)	
			3500	1.33		1859	0.041	710	1.32		3009	0.066	1620	1.32		3983	0.088	1620	1.32		5531	0.122	1620	1.34		7655	0.171	1620
2	7	C	1750	0.665	2632	1859	0.021	710	0.659	2655	3009	0.033	1620	0.659	2655	3983	0.044	1620	0.661	2649	5531	0.062	1620	0.668	2619	7655	0.086	1620
			1160	0.441		1859	0.014	710	0.437		3009	0.022	1620	0.437		3983	0.029	1620	0.438		5531	0.041	1620	0.443		7655	0.057	1620
			875	0.332		1859	0.010	710	0.330		3009	0.017	1620	0.330		3983	0.022	1620	0.330		5531	0.031	1620	0.334		7655	0.043	1620
			3500	1.14		1859	0.035	710	1.13		3009	0.057	1620	1.13		3983	0.075	1620	1.13		5531	0.105	1620	1.15		7655	0.147	1620
3	2	C	1750	0.665	3068	1859	0.018	710	0.565	3095	3009	0.029	1620	0.565	3095	3983	0.038	1620	0.567	3088	5531	0.053	1620	0.573	3053	7655	0.074	1620
			1160	0.378		1859	0.012	710	0.375		3009	0.019	1620	0.375		3983	0.025	1620	0.376		5531	0.035	1620	0.380		7655	0.049	1620
			875	0.285		1859	0.009	710	0.283		3009	0.014	1620	0.283		3983	0.019	1620	0.283		5531	0.026	1620	0.287		7655	0.037	1620
			3500	0.95		1859	0.030	710	0.96		3009	0.048	1620	0.96		3983	0.064	1620	0.91		5531	0.084	1620	0.96		7655	0.123	1620
3	6	C	1750	0.665	3681	1859	0.015	710	0.479	3650	3009	0.024	1620	0.479	3650	3983	0.032	1620	0.457	3832	5531	0.043	1620	0.481	3641	7655	0.062	1620
			1160	0.315		1859	0.010	710	0.318		3009	0.016	1620	0.318		3983	0.021	1620	0.303		5531	0.028	1620	0.319		7655	0.041	1620
			875	0.238		1859	0.007	710	0.240		3009	0.012	1620	0.240		3983	0.016	1620	0.228		5531	0.021	1620	0.240		7655	0.031	1620
			3500	0.86		1859	0.027	710	0.86		3009	0.043	1620	0.86		3983	0.057	1620	0.82		5531	0.076	1620	0.87		7655	0.111	1620
4	0	C	1750	0.665	4091	1859	0.013	710	0.432	4055	3009	0.022	1620	0.432	4055	3983	0.026	1620	0.411	4258	5531	0.038	1620	0.433	4046	7655	0.056	1620
			1160	0.284		1859	0.009	710	0.286		3009	0.015	1620	0.286		3983	0.018	1620	0.272		5531	0.025	1620	0.287		7655	0.037	1620
			875	0.214		1859	0.007	710	0.216		3009	0.011	1620	0.216		3983	0.013	1620	0.206		5531	0.019	1620	0.216		7655	0.028	1620
			3500	0.76		1859	0.024	710	0.79		3009	0.040	1620	0.79		3983	0.052	1620	0.70		5531	0.064	1620	0.79		7655	0.101	1620
4	6	C	1750	0.665	4609	1859	0.012	710	0.394	4440	3009	0.020	1620	0.394	4440	3983	0.026	1620	0.349	5021	5531	0.033	1620	0.395	4431	7655	0.051	1620
			1160	0.252		1859	0.008	710	0.261		3009	0.013	1620	0.261		3983	0.018	1620	0.231		5531	0.022	1620	0.262		7655	0.034	1620
			875	0.190		1859	0.006	710	0.197		3009	0.010	1620	0.197		3983	0.013	1620	0.174		5531	0.016	1620	0.197		7655	0.026	1620
			3500	0.63		1859	0.020	710	0.65		3009	0.033	1620	0.65		3983	0.044	1620	0.58		5531	0.053	1620	0.66		7655	0.084	1620
5	5	C	1750	0.665	5550	1859	0.010	710	0.327	5347	3009	0.017	1620	0.327	5347	3983	0.022	1620	0.289	6046	5531	0.027	1620	0.328	5335	7655	0.042	1620
			1160	0.209		1859	0.007	710	0.217		3009	0.011	1620	0.217		3983	0.015	1620	0.192		5531	0.018	1620	0.217		7655	0.028	1620
			875	0.158		1859	0.005	710	0.164		3009	0.008	1620	0.164		3983	0.011	1620	0.145		5531	0.014	1620	0.164		7655	0.021	1620
			3500	0.54		1797	0.016	710	0.53		3009	0.027	1620	0.53		3983	0.036	1620	0.53		5531	0.049	1620	0.55		7655	0.070	1620
6	5	C	1750	0.665	6452	1797	0.008	710	0.267	6553	3009	0.014	1620	0.267	6553	3983	0.018	1620	0.264	6620	5531	0.025	1620	0.273	6403	7655	0.035	1620
			1160	0.180		1797	0.005	710	0.177		3009	0.009	1620	0.177		3983	0.012	1620	0.175		5531	0.016	1620	0.181		7655	0.023	1620
			875	0.136		1797	0.004	710	0.134		3009	0.007	1620	0.134		3983	0.009	1620	0.132		5531	0.012	1620	0.137		7655	0.018	1620
			3500	0.47		1797	0.014	710	0.47		3009	0.023	1620	0.47		3983	0.031	1620	0.46		5531	0.043	1620	0.48		7655	0.061	1620
7	4	C	1750	0.665	7396	1797	0.007	710	0.233	7511	3009	0.012	1620	0.233	7511	3983	0.016	1620	0.231	7588	5531	0.022	1620	0.238	7339	7655	0.031	1620
			1160	0.157		1797	0.005	710	0.154		3009	0.008	1620	0.154		3983	0.010	1620	0.153		5531	0.014	1620	0.158		7655	0.020	1620
			875	0.118		1797	0.004	710	0.116		3009	0.006	1620	0.116		3983	0.008	1620	0.115		5531	0.011	1620	0.119		7655	0.015	1620
			3500	0.42		1797	0.013	710	0.42		3009	0.021	1620	0.42		3363	0.023	1620	0.41		5531	0.037	1620	0.42		6416	0.044	1620
8	4	C	1750	0.665	8394	1797	0.006	710	0.209	8372	3009	0.011	1620	0.209	8372	3363	0.012	1620	0.203	8624	5531	0.019	1620	0.207	8443	6416	0.022	1620
			1160	0.138		1797	0.004	710	0.139		3009	0.007	1620	0.139		3363	0.008	1620	0.135		5531	0.013	1620	0.137		6416	0.015	1620
			875	0.104		1797	0.003	710	0.105		3009	0.005	1620	0.105		3363	0.006	1620	0.101		5531	0.009	1620	0.104		6416	0.011	1620
			3500	0.37		1797	0.011	710	0.37		3009	0.018	1620	0.37		3363	0.021	1620	0.00		5487	0.034	1620	0.37		6416	0.039	1620
9	5	C	1750	0.665	9540	1797	0.006	710	0.184	9514	3009	0.009	1620	0.184	9514	3363	0.010	1620	0.000	9300	5487	0.017	1620	0.182	9596	6416	0.020	1620
			1160	0.122		1797	0.004	710	0.122		3009	0.006	1620	0.122		3363	0.007	1620	0.000		5487	0.012	1620	0.121		6416	0.013	1620
			875	0.092		1797	0.003	710	0.092		3009	0.005	1620	0.092		3363	0.005	1620	0.000		5487	0.009	1620	0.091		6416	0.010	1620
			3500	0.32		1797	0.010	710	0.33		2390	0.013	1620	0.33		2390	0.013	1620	0.00		5487	0.030	1620	0.33		6416	0.035	1620
1	0	K	1750	0.665	10845	1797	0.005	710	0.164	10670	2390	0.007	1620	0.164	10670	2390	0.007	1620	0.000	10569	5487	0.015	1620	0.164	10662	6416	0.018	1620
			1160	0.107		1797	0.003	710	0.109		2390	0.004	1620	0.109		2390	0.004											

SERIES M

QUINTUPLE REDUCTION RATINGS

SIZES M08 - M14

Note: Input Power, Pm may exceed thermal limit,
Check thermal power page 83

Pm - Input Power (HP)
M2 - Output Torque (lb.in)
i - Exact Ratio (:1)
N2 - Output Speed (rpm)
fra - Overhung Load (lbf)

Column Entry	Input Speed N1 (rpm)	M0852					M0951					M1051					M1351					M1451				
		N2	i	M2	Pm	fra	N2	i	M2	Pm	fra	N2	i	M2	Pm	fra	N2	i	M2	Pm	fra	N2	i	M2	Pm	fra
6 7 8	3500	1.28		15045	0.322	3645	1.35		25311	0.570	6300	1.43		39029	0.933	9000	1.38		56198	1.296	14400	1.28		94695	2.017	17775
	1750	0.641	2728	15045	0.163	3645	0.674	2598	25311	0.288	6300	0.716	2446	39029	0.503	9000	0.690	2536	56198	0.655	14400	0.638	2744	94695	1.019	17775
	1160	0.425		15071	0.108	3645	0.447		25311	0.191	6300	0.474		39029	0.312	9000	0.457		56198	0.434	14400	0.423		94695	0.676	17775
	875	0.321		15045	0.081	3645	0.337		25311	0.144	6300	0.358		39029	0.236	9000	0.345		56198	0.327	14400	0.319		94695	0.510	17775
	3500	1.07		15045	0.269	3645	1.12		25311	0.474	6300	1.15		39029	0.752	9000	1.11		56198	1.044	14400	1.03		94695	1.626	17775
3 2 C	1750	0.534	3274	15045	0.136	3645	0.561	3119	25311	0.240	6300	0.577	3035	39029	0.405	9000	0.556	3146	56198	0.528	14400	0.514	3405	94695	0.822	17775
	1160	0.354		15071	0.090	3645	0.372		25311	0.159	6300	0.382		39029	0.252	9000	0.369		56198	0.350	14400	0.341		94695	0.545	17775
	875	0.267		15045	0.068	3645	0.281		25311	0.120	6300	0.288		39029	0.190	9000	0.278		56198	0.264	14400	0.257		94695	0.411	17775
	3500	0.92		15045	0.230	3645	0.94		25311	0.395	6300	0.98		39029	0.638	9000	0.94		56198	0.885	14400	0.87		94695	1.379	17775
3 6 C	1750	0.458	3818	15045	0.116	3645	0.468	3742	25311	0.200	6300	0.489	3579	39029	0.344	9000	0.472	3710	56198	0.447	14400	0.436	4015	94695	0.697	17775
	1160	0.304		15071	0.077	3645	0.310		25311	0.132	6300	0.324		39029	0.214	9000	0.313		56198	0.297	14400	0.289		94695	0.462	17775
	875	0.229		15045	0.058	3645	0.234		25311	0.100	6300	0.245		39029	0.161	9000	0.236		56198	0.224	14400	0.218		94695	0.348	17775
	3500	0.81		15045	0.204	3645	0.83		25311	0.351	6300	0.89		39029	0.582	9000	0.86		56198	0.809	14400	0.80		94695	1.259	17775
4 0 C	1750	0.407	4302	15045	0.103	3645	0.415	4216	25311	0.177	6300	0.447	3919	39029	0.314	9000	0.431	4062	56198	0.409	14400	0.398	4396	94695	0.636	17775
	1160	0.270		15071	0.068	3645	0.275		25311	0.118	6300	0.296		39029	0.195	9000	0.286		56198	0.271	14400	0.264		94695	0.422	17775
	875	0.203		15045	0.052	3645	0.208		25311	0.089	6300	0.223		39029	0.147	9000	0.215		56198	0.204	14400	0.199		94695	0.318	17775
	3500	0.74		15045	0.186	3645	0.75		25311	0.318	6300	0.78		39029	0.505	9000	0.77		56198	0.726	14400	0.70		89385	1.052	17775
4 6 C	1750	0.370	4726	15045	0.094	3645	0.376	4655	25311	0.161	6300	0.388	4515	39029	0.272	9000	0.387	4525	56198	0.367	14400	0.352	4969	89385	0.531	17775
	1160	0.245		15071	0.062	3645	0.249		25311	0.106	6300	0.257		39029	0.169	9000	0.256		56198	0.243	14400	0.233		89385	0.352	17775
	875	0.185		15045	0.047	3645	0.188		25311	0.080	6300	0.194		39029	0.128	9000	0.193		56198	0.183	14400	0.176		89385	0.266	17775
	3500	0.64		15045	0.160	3645	0.65		25311	0.273	6300	0.63		39029	0.412	9000	0.63		56198	0.592	14400	0.64		89385	0.960	17775
5 5 C	1750	0.319	5494	15045	0.081	3645	0.323	5411	25311	0.138	6300	0.316	5533	39029	0.222	9000	0.316	5545	56198	0.299	14400	0.322	5441	89385	0.485	17775
	1160	0.211		15071	0.054	3645	0.214		25311	0.092	6300	0.210		39029	0.138	9000	0.209		56198	0.198	14400	0.213		89385	0.322	17775
	875	0.159		15045	0.040	3645	0.162		25311	0.069	6300	0.158		39029	0.104	9000	0.158		56198	0.150	14400	0.161		89385	0.243	17775
	3500	0.52		15045	0.131	3645	0.52		21948	0.190	6300	0.57		37701	0.361	9000	0.52		56198	0.484	14400	0.53		89385	0.784	17775
6 5 C	1750	0.260	6733	15045	0.066	3645	0.260	6742	21948	0.096	6300	0.287	6106	37701	0.195	9000	0.258	6783	56198	0.245	14400	0.262	6668	89385	0.396	17775
	1160	0.172		15071	0.044	3645	0.172		21948	0.064	6300	0.190		37701	0.121	9000	0.171		56198	0.162	14400	0.174		89385	0.262	17775
	875	0.130		15045	0.033	3645	0.130		21948	0.048	6300	0.143		37701	0.091	9000	0.129		56198	0.122	14400	0.131		89385	0.198	17775
	3500	0.46		15045	0.115	3645	0.46		21948	0.168	6300	0.47		37701	0.295	9000	0.46		56198	0.434	14400	0.47		89385	0.703	17775
7 4 C	1750	0.229	7641	15045	0.058	3645	0.229	7652	21948	0.085	6300	0.234	7483	37701	0.159	9000	0.231	7561	56198	0.220	14400	0.235	7432	89385	0.355	17775
	1160	0.152		15071	0.039	3645	0.152		21948	0.056	6300	0.155		37701	0.099	9000	0.153		56198	0.146	14400	0.156		89385	0.235	17775
	875	0.115		15045	0.029	3645	0.114		21948	0.042	6300	0.117		37701	0.074	9000	0.116		56198	0.110	14400	0.118		89385	0.178	17775
	3500	0.42		15045	0.105	3645	0.41		25311	0.175	6300	0.42		37701	0.264	9000	0.41		56198	0.387	14400	0.42		89385	0.627	17775
8 4 C	1750	0.210	8344	15045	0.053	3645	0.207	8449	25311	0.088	6300	0.210	8340	37701	0.142	9000	0.206	8479	56198	0.196	14400	0.210	8335	89385	0.317	17775
	1160	0.139		15071	0.035	3645	0.137		25311	0.059	6300	0.139		37701	0.089	9000	0.137		56198	0.130	14400	0.139		89385	0.210	17775
	875	0.105		15045	0.027	3645	0.104		25311	0.044	6300	0.105		37701	0.067	9000	0.103		56198	0.098	14400	0.105		89385	0.158	17775
	3500	0.37		15045	0.093	3645	0.36		25311	0.154	6300	0.37		37701	0.236	9000	0.37		50445	0.311	14400	0.34		82128	0.471	17775
9 5 C	1750	0.184	9486	15045	0.047	3645	0.182	9605	25311	0.078	6300	0.187	9354	37701	0.127	9000	0.184	9490	50445	0.157	14400	0.172	10192	82128	0.238	17775
	1160	0.122		15071	0.031	3645	0.121		25311	0.052	6300	0.124		37701	0.079	9000	0.122		50445	0.104	14400	0.114		82128	0.158	17775
	875	0.092		15045	0.023	3645	0.091		25311	0.039	6300	0.094		37701	0.060	9000	0.092		50445	0.079	14400	0.086		82128	0.119	17775
	3500	0.32		13718	0.073	3645	0.29		21948	0.107	6300	0.35		37436	0.218	9000	0.35		53366	0.309	14400	0.31		82128	0.420	17775
1 0 K	1750	0.160	10924	13718	0.037	3645	0.146	11966	21948	0.054	6300	0.174	10048	37436	0.117	9000	0.173	10097	53366	0.156	14400	0.153	11430	82128	0.212	17775
	1160	0.106		13741	0.025	3645	0.097		21948	0.036	6300	0.115		37436	0.073	9000	0.115		53366	0.103	14400	0.101		82128	0.141	17775
	875	0.080		13718	0.019	3645	0.073		21948	0.027	6300	0.087		37436	0.055	9000	0.087		53366	0.078						

SERIES M

DIMENSIONS - TRIPLE REDUCTION BASE MOUNT

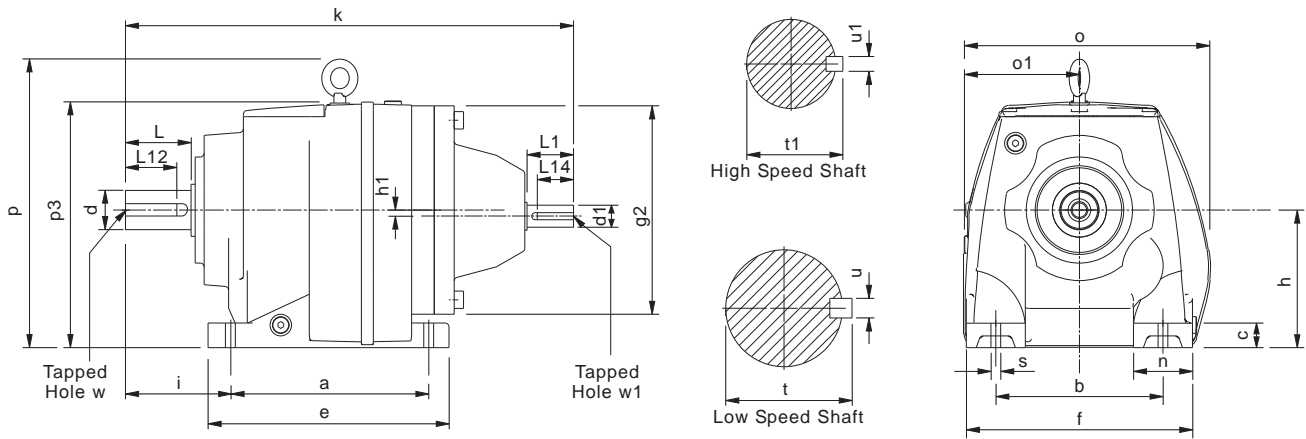

SIZE	a	b	c	e	f	g2	h	h1	i	k	n	o	o1	p	p3	s
M0132	4.33	4.33	0.47	5.16	5.31	5.51	2.95	-	2.28	11.85	0.98	5.98	2.99	-	5.87	0.39
M0232	5.12	4.33	0.63	5.98	5.71	5.51	3.54	-	2.95	12.99	1.38	6.69	3.31	-	7.09	0.39
M0332	5.12	4.33	0.63	5.98	5.71	5.51	3.54	-	2.95	12.99	1.38	6.69	3.31	-	7.09	0.39
M0432	6.50	5.31	0.79	7.87	7.48	7.09	4.53	-	3.54	14.84	2.17	8.03	3.82	-	8.19	0.59
M0532	6.50	5.31	0.79	7.87	7.48	7.09	4.53	-	3.94	15.24	2.17	8.03	3.82	-	8.19	0.59
M0632	7.68	5.91	0.94	9.25	8.27	7.09	5.12	0.57	3.94	16.06	2.36	8.66	4.33	9.69	8.43	0.59
M0732	8.07	6.69	0.98	9.65	9.06	8.35	5.51	-	4.53	17.80	2.36	9.92	4.69	11.61	9.84	0.75
M0832	10.24	8.46	1.38	12.20	11.42	9.84	7.09	-	5.51	21.26	2.95	12.60	6.57	14.17	12.20	0.75
M0931	12.20	9.84	1.57	14.37	13.39	11.81	8.86	-	6.30	26.06	3.54	14.65	7.87	17.05	15.51	0.91
M1031	14.57	11.42	1.77	17.32	15.75	14.17	9.84	-	7.28	30.82	4.33	16.85	8.86	19.88	17.56	1.06
M1331	16.14	13.39	1.97	19.29	17.72	15.75	10.43	-	8.66	38.15	4.33	18.50	9.53	22.17	19.02	1.34
M1431	19.69	14.96	1.97	23.23	20.87	18.11	11.81	-	10.24	43.07	5.91	21.50	10.94	24.80	21.69	1.61

SIZE	High Speed Shaft						Low Speed Shaft					
	d1	L1	L14	t1	u1	w1	d	L	L12	t	u	w
M0132	0.6250 0.6245	1.57	19/32	0.70	3/16	1/4 UNF x .63 deep	0.7500 0.7495	1.575	19/32	0.829	3/16	1/4 UNF x 0.63 deep
M0232	0.6250 0.6245	1.57	19/32	0.70	3/16	1/4 UNF x .63 deep	1.0000 0.9995	1.969	19/16	1.106	1/4	1/4 UNF x 0.71 deep
M0332	0.6250 0.6245	1.57	19/32	0.70	3/16	1/4 UNF x .63 deep	1.0000 0.9995	1.969	19/16	1.106	1/4	1/4 UNF x 0.71 deep
M0432	0.6250 0.6245	1.57	19/32	0.70	3/16	1/4 UNF x .63 deep	1.2500 1.2495	2.362	2	1.359	1/4	3/8 UNF x 0.86 deep
M0532	0.6250 0.6245	1.57	19/32	0.70	3/16	1/4 UNF x .63 deep	1.3750 1.3745	2.756	23/8	1.507	5/16	3/8 UNF x 0.75 deep
M0632	0.6250 0.6245	1.57	19/32	0.70	3/16	1/4 UNF x .63 deep	1.3750 1.3745	2.756	23/8	1.507	5/16	3/8 UNF x 0.75 deep
M0732	0.7500 0.7495	1.57	19/32	0.83	3/16	1/4 UNF x .63 deep	1.625 1.624	3.15	23/8	1.784	3/8	5/8 UNF x 1.25 deep
M0832	0.8750 0.8745	1.97	19/32	0.96	3/16	5/16 UNF x .63 deep	2.125 2.124	3.937	23/4	2.338	1/2	3/4 UNF x 1.50 deep
M0931	1.1250 1.1245	2.36	2	1.23	1/4	3/8 UNF x .87 deep	2.375 2.374	4.72	311/16	2.65	0.625	3/4 UNF x 1.65 deep
M1031	1.3750 1.3745	3.15	213/32	1.51	5/16	1/2 UNF x 1.10 deep	2.875 2.874	5.51	45/8	3.20	0.75	3/4 UNF x 1.65 deep
M1331	2.125 2.124	4.33	313/16	2.35	1/2	3/4 UNF x 1.65 deep	3.625 3.624	6.69	515/16	4.01	0.875	1 UNF x 1.97 deep
M1431	2.125 2.124	4.33	313/16	2.35	1/2	3/4 UNF x 1.65 deep	4.000 3.999	8.27	71/2	4.44	1.00	1 UNF x 1.97 deep

SERIES M

DIMENSIONS - QUADRUPLE REDUCTION BASE MOUNT

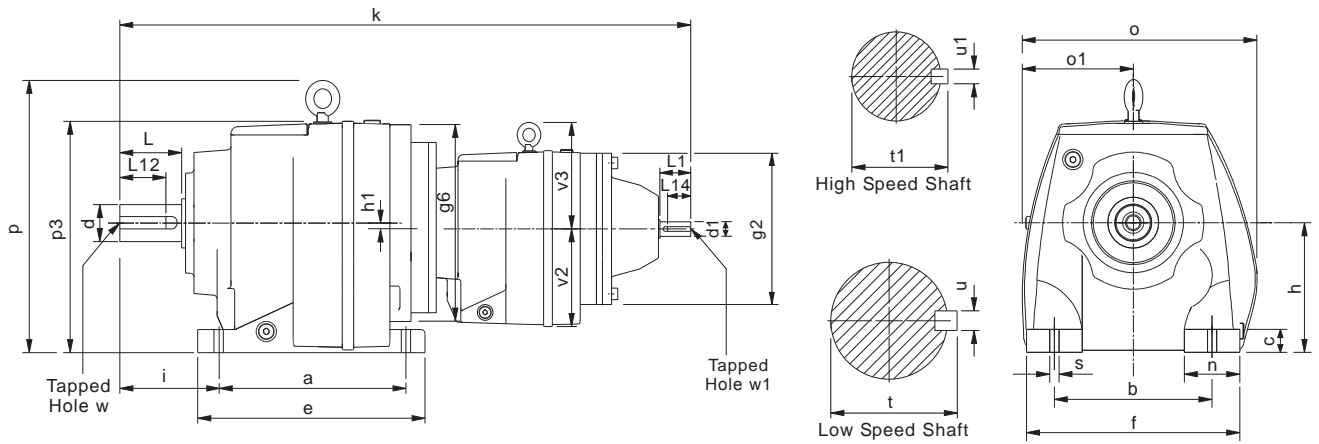

SIZE	a	b	c	e	f	g2	g6	h	h1	i	k	n	o	o1	p	p3	s	v2	v3
M0342	5.12	4.33	0.63	5.98	5.71	5.51	5.51	3.54	-	2.95	19.80	1.38	6.69	3.31	-	7.09	0.39	2.99	-
M0442	6.50	5.31	0.79	7.87	7.48	5.51	7.09	4.53	-	3.54	22.48	2.17	8.03	3.82	-	8.19	0.59	3.58	-
M0542	6.50	5.31	0.79	7.87	7.48	5.51	7.09	4.53	-	3.94	22.87	2.17	8.03	3.82	-	8.19	0.59	3.58	-
M0642	7.68	5.91	0.94	9.25	8.27	5.51	7.09	5.12	0.57	3.94	23.70	2.36	8.66	4.33	9.69	8.43	0.59	3.58	-
M0742	8.07	6.69	0.98	9.65	9.06	5.51	8.35	5.51	-	4.53	25.16	2.36	9.92	4.69	11.61	9.84	0.75	3.58	-
M0842	10.24	8.46	1.38	12.20	11.42	7.09	9.84	7.09	-	5.51	29.57	2.95	12.60	6.57	14.17	12.20	0.75	4.53	-
M0941	12.20	9.84	1.57	14.37	13.39	7.09	9.84	8.86	-	6.30	32.76	3.54	14.65	7.87	17.05	15.51	0.91	4.45	-
M1041	14.57	11.42	1.77	17.32	15.75	7.09	11.81	9.84	-	7.28	37.64	4.33	16.85	8.86	19.88	17.56	1.06	5.43	6.10
M1341	16.14	13.39	1.97	19.29	17.72	8.35	13.78	10.43	-	8.66	42.40	4.33	18.50	9.53	22.17	19.02	1.34	7.36	6.10
M1441	19.69	14.96	1.97	23.23	20.87	8.35	13.78	11.81	-	10.24	46.93	5.91	21.50	10.94	24.80	21.69	1.61	7.36	6.10

SIZE	High Speed Shaft							Low Speed Shaft					
	d1	L1	L14	t1	u1	w1	d	L	L12	t	u	w	
M0342	0.6250 0.6245	1.57	1 9/32	0.70	3/16	1/4 UNF x .63 deep	1.0000 0.9995	1.969	1 9/16	1.106	1/4	1/4 UNF x 0.71 deep	
M0442	0.6250 0.6245	1.57	1 9/32	0.70	3/16	1/4 UNF x .63 deep	1.2500 1.2495	2.362	2	1.359	1/4	3/8 UNF x 0.86 deep	
M0542	0.6250 0.6245	1.57	1 9/32	0.70	3/16	1/4 UNF x .63 deep	1.3750 1.3745	2.756	2 3/8	1.507	5/16	3/8 UNF x 0.75 deep	
M0642	0.6250 0.6245	1.57	1 9/32	0.70	3/16	1/4 UNF x .63 deep	1.3750 1.3745	2.756	2 3/8	1.507	5/16	3/8 UNF x 0.75 deep	
M0742	0.6250 0.6245	1.57	1 9/32	0.70	3/16	1/4 UNF x .63 deep	1.6250 1.6240	3.15	2 3/8	1.784	3/8	5/8 UNF x 1.25 deep	
M0842	0.7500 0.7495	1.57	1 9/32	0.83	3/16	1/4 UNF x .63 deep	2.1250 2.1240	3.937	2 3/4	2.338	1/2	3/4 UNF x 1.50 deep	
M0941	0.7500 0.7495	1.57	1 9/32	0.83	3/16	1/4 UNF x .63 deep	2.3750 2.3740	4.72	3 11/16	2.65	0.625	3/4 UNF x 1.65 deep	
M1041	0.8750 0.8745	1.97	1 9/32	0.96	3/16	5/16 UNF x .63 deep	2.875 2.874	5.51	4 5/8	3.20	0.75	3/4 UNF x 1.65 deep	
M1341	0.8750 0.8745	1.97	1 9/32	0.96	3/16	5/16 UNF x .63 deep	3.625 3.624	6.69	5 15/16	4.01	0.875	1 UNF x 1.97 deep	
M1441	0.8750 0.8745	1.97	1 9/32	0.96	3/16	5/16 UNF x .63 deep	4.000 3.999	8.27	7 1/2	4.44	1.00	1 UNF x 1.97 deep	

SERIES M

DIMENSIONS - QUINTUPLE REDUCTION BASE MOUNT

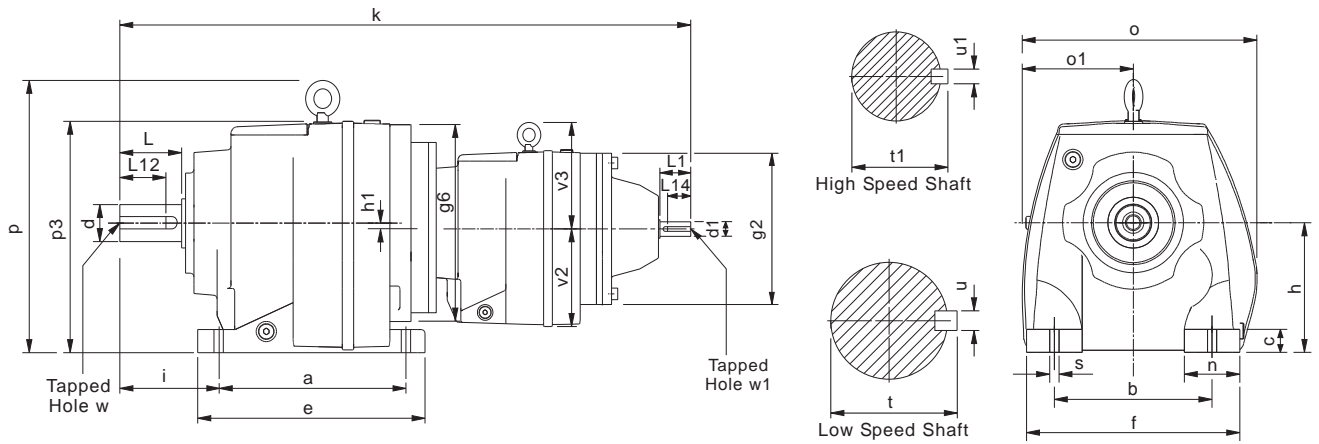

SIZE	a	b	c	e	f	g2	g6	h	h1	i	k	n	o	o1	p	p3	s	v2	v3
M0352	5.12	4.33	0.63	5.98	5.7	5.51	5.51	3.54	-	2.95	20.39	1.38	6.69	3.31	-	7.09	0.39	2.99	-
M0452	6.50	5.31	0.79	7.87	7.5	5.51	7.09	4.53	-	3.54	22.99	2.17	8.03	3.82	-	8.19	0.59	3.58	-
M0552	6.50	5.31	0.79	7.87	7.5	5.51	7.09	4.53	-	3.94	23.39	2.17	8.03	3.82	-	8.19	0.59	3.58	-
M0652	7.68	5.91	0.94	9.25	8.3	5.51	7.09	5.12	0.57	3.94	24.21	2.36	8.66	4.33	9.69	8.43	0.59	3.58	-
M0752	8.07	6.69	0.98	9.65	9.1	5.51	8.35	5.51	-	4.53	25.67	2.36	9.92	4.69	11.61	9.84	0.75	3.58	-
M0852	10.24	8.46	1.38	12.20	11	7.09	9.84	7.09	-	5.51	29.88	2.95	12.60	6.57	14.17	12.20	0.75	4.53	-
M0951	12.20	9.84	1.57	14.37	13	7.09	9.84	8.86	-	6.30	33.07	3.54	14.65	7.87	17.05	15.51	0.91	4.45	-
M1051	14.57	11.42	1.77	17.32	16	7.09	11.81	9.84	-	7.28	38.11	4.33	16.85	8.86	19.88	17.56	1.06	5.43	6.10
M1351	16.14	13.39	1.97	19.29	18	8.35	13.78	10.43	-	8.66	42.87	4.33	18.50	9.53	22.17	19.02	1.34	7.36	6.10
M1451	19.69	14.96	1.97	23.23	21	8.35	13.78	11.81	-	10.24	47.40	5.91	21.50	10.94	24.80	21.69	1.61	7.36	6.10

SIZE	High Speed Shaft							Low Speed Shaft					
	d1	L1	L14	t1	u1	w1	d	L	L12	t	u	w	
M0352	0.6250 0.6245	1.57	1 9/32	0.70	3/16	1/4 UNF x .63 deep	1.0000 0.9995	1.969	19/16	1.106	1/4	1/4 UNF x 0.71 deep	
M0452	0.6250 0.6245	1.57	1 9/32	0.70	3/16	1/4 UNF x .63 deep	1.2500 1.2495	2.362	2	1.359	1/4	3/8 UNF x 0.86 deep	
M0552	0.6250 0.6245	1.57	1 9/32	0.70	3/16	1/4 UNF x .63 deep	1.3750 1.3745	2.756	23/8	1.507	5/16	3/8 UNF x 0.75 deep	
M0652	0.6250 0.6245	1.57	1 9/32	0.70	3/16	1/4 UNF x .63 deep	1.3750 1.3745	2.756	23/8	1.507	5/16	3/8 UNF x 0.75 deep	
M0752	0.6250 0.6245	1.57	1 9/32	0.70	3/16	1/4 UNF x .63 deep	1.6250 1.6240	3.15	23/8	1.784	3/8	5/8 UNF x 1.25 deep	
M0852	0.6250 0.6245	1.57	1 9/32	0.70	3/16	1/4 UNF x .63 deep	2.1250 2.1240	3.937	23/4	2.338	1/2	3/4 UNF x 1.50 deep	
M0951	0.6250 0.6245	1.57	1 9/32	0.70	3/16	1/4 UNF x .63 deep	2.3750 2.3740	4.72	311/16	2.65	0.625	3/4 UNF x 1.65 deep	
M1051	0.7500 0.7495	1.57	1 9/32	0.83	3/16	1/4 UNF x .63 deep	2.875 2.874	5.51	45/8	3.20	0.75	3/4 UNF x 1.65 deep	
M1351	0.7500 0.7495	1.57	1 9/32	0.83	3/16	1/4 UNF x .63 deep	3.625 3.624	6.69	515/16	4.01	0.875	1 UNF x 1.97 deep	
M1451	0.7500 0.7495	1.57	1 9/32	0.83	3/16	1/4 UNF x .63 deep	4.000 3.999	8.27	71/2	4.44	1.00	1 UNF x 1.97 deep	

SERIES M

DIMENSIONS - DOUBLE REDUCTION FLANGE MOUNT

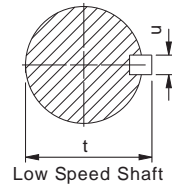
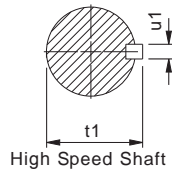
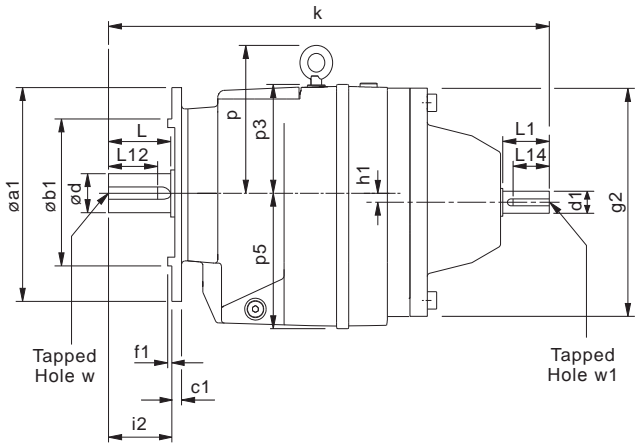

Sizes
1, 2, 3, 4, 5, 6, 7 and 8

Sizes
9, 10, 13 and 14

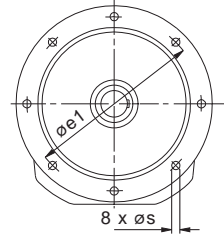
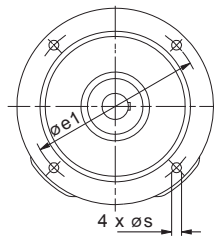

Note: Sizes 01 to 08 are also available as C-Flange (B14) mounting, please see page 82 for details

SIZE	$\phi a1$	$\phi b1$	$c1$	$\phi e1$	$f1$	$\phi g2$	$h1$	$i2$	k	p	$p3$	$p5$	s
M0122	4.72	3.15	0.35	3.94	0.12	5.51	-	1.57	11.26	-	2.91	2.99	0.35
	5.51	3.74	0.35	4.53	0.12			1.57					0.35
	6.30	4.33	0.39	5.12	0.14			1.57					0.35
	7.87	5.12	0.39	6.50	0.14			1.57					0.43
M0222	4.72	3.15	0.39	3.94	0.12	5.51	-	1.97	12.48	-	3.54	3.58	0.26
	5.51	3.74	0.39	4.53	0.12			1.97					0.35
	6.30	4.33	0.39	5.12	0.14			1.97					0.35
	7.87	5.12	0.39	6.50	0.14			1.97					0.43
M0322	4.72	3.15	0.39	3.94	0.12	5.51	-	1.97	12.48	-	3.54	3.58	0.26
	5.51	3.74	0.39	4.53	0.12			1.97					0.35
	6.30	4.33	0.39	5.12	0.14			1.97					0.35
	7.87	5.12	0.39	6.50	0.14			1.97					0.43
M0422	5.51	3.74	0.43	4.53	0.12	7.09	-	2.36	14.53	-	3.66	4.53	0.35
	6.30	4.33	0.43	5.12	0.14			2.36					0.35
	7.87	5.12	0.43	6.50	0.14			2.36					0.43
	9.84	7.09	0.43	8.46	0.16			2.36					0.53
M0522	5.51	3.74	0.43	4.53	0.12	7.09	-	2.76	14.92	-	3.66	4.53	0.35
	6.30	4.33	0.43	5.12	0.14			2.76					0.43
	7.87	5.12	0.43	6.50	0.14			2.76					0.43
	9.84	7.09	0.43	8.46	0.16			2.76					0.53
M0622	7.87	5.12	0.43	6.50	0.16	7.09	0.57	2.76	15.75	4.57	3.31	5.12	0.43
	9.84	7.09	0.43	8.46	0.16			2.76					0.53
	11.81	9.06	0.43	10.43	0.16			2.76					0.53
	13.78	9.84	0.43	12.40	0.16			2.76					0.53
M0722	7.87	5.12	0.43	6.50	0.14	8.35	-	3.15	17.32	6.10	4.33	5.51	0.43
	9.84	7.09	0.43	8.46	0.16			3.15					0.53
	11.81	9.06	0.43	10.43	0.16			3.15					0.53
M0822	11.81	9.06	0.67	10.43	0.16	9.84	-	3.94	21.85	7.09	5.12	7.17	0.53
	13.78	9.84	0.67	11.81	0.20			3.94					0.69
M0921	17.72	13.78	0.71	15.75	0.20	11.81	-	5.51	25.98	7.80	-	9.06	0.71
M1021	17.72	13.78	0.87	15.75	0.20	14.17	-	5.51	30.79	9.65	-	10.24	0.71
M1321	21.65	17.72	0.98	19.69	0.20	15.75	-	6.69	35.71	11.34	-	10.94	0.71
M1421	21.65	17.72	0.98	19.69	0.20	18.11	-	8.27	40.24	12.60	-	12.52	0.71

SIZE	High Speed Shaft						Low Speed Shaft					
	$d1$	$L1$	$L14$	$t1$	$u1$	$w1$	d	L	$L12$	t	u	w
M0122	0.6250	1.57	1 9/32	0.70	3/16	1/4 UNF x .63 deep	0.7500	1.575	19/32	0.829	3/16	1/4 UNF x 0.63 deep
	0.6245						0.7495					
M0222	0.6250	1.57	1 9/32	0.70	3/16	1/4 UNF x .63 deep	1.0000	1.969	19/16	1.106	1/4	1/4 UNF x 0.71 deep
	0.6245						0.9995					
M0322	0.6250	1.57	1 9/32	0.70	3/16	1/4 UNF x .63 deep	1.0000	1.969	19/16	1.106	1/4	1/4 UNF x 0.71 deep
	0.6245						0.9995					
M0422	0.7500	1.57	1 9/32	0.83	3/16	1/4 UNF x .63 deep	1.2500	2.362	2	1.359	1/4	3/8 UNF x 0.86 deep
	0.7495						1.2495					
M0522	0.7500	1.57	1 9/32	0.83	3/16	1/4 UNF x .63 deep	1.3750	2.756	23/8	1.507	5/16	3/8 UNF x 0.75 deep
	0.7495						1.3745					
M0622	0.7500	1.57	1 9/32	0.83	3/16	1/4 UNF x .63 deep	1.3750	2.756	23/8	1.507	5/16	3/8 UNF x 0.75 deep
	0.7495						1.3745					
M0722	0.8750	1.97	1 9/32	0.96	3/16	5/16 UNF x .63 deep	1.6250	3.15	23/8	1.784	3/8	5/8 UNF x 1.25 deep
	0.8745						1.6240					
M0822	1.1250	2.36	1 9/32	1.23	1/4	3/8 UNF x .87 deep	2.1250	3.937	23/4	2.338	1/2	3/4 UNF x 1.50 deep
	1.1245						2.1240					
M0921	1.3750	3.15	2	1.51	5/16	1/2 UNF x 1.10 deep	2.3750	4.72	311/16	2.65	0.625	3/4 UNF x 1.65 deep
	1.3745						2.3740					
M1021	1.6250	4.33	2 13/32	1.79	3/8	5/8 UNF x 1.42 deep	2.875	5.51	45/8	3.20	0.75	3/4 UNF x 1.65 deep
	1.6240						2.874					
M1321	2.1250	4.33	3 13/16	2.35	1/2	3/4 UNF x 1.65 deep	3.625	6.69	515/16	4.01	0.875	1 UNF x 1.97 deep
	2.1240						3.624					
M1421	2.1250	4.33	3 13/16	2.35	1/2	3/4 UNF x 1.65 deep	4.000	8.27	71/2	4.44	1.00	1 UNF x 1.97 deep
	2.1240						3.999					

SERIES M

DIMENSIONS - TRIPLE REDUCTION FLANGE MOUNT

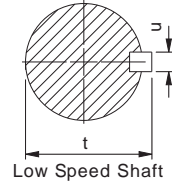
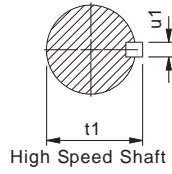
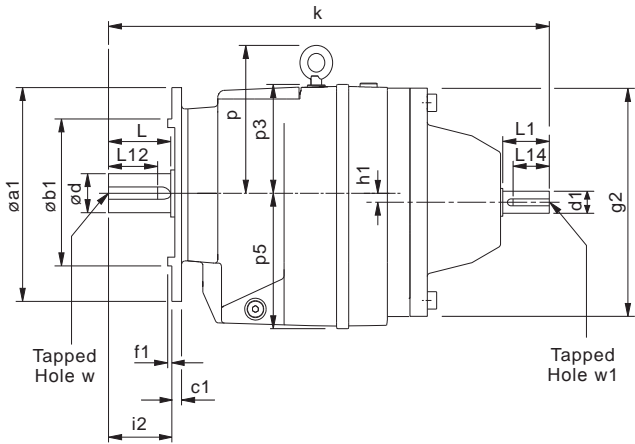

Sizes
1, 2, 3, 4, 5, 6, 7 and 8

Sizes
9, 10, 13 and 14

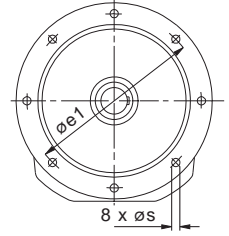
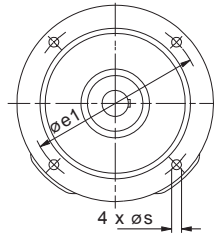

Note: Sizes 01 to 08 are also available as C-Flange (B14) mounting, please see page 82 for details

SIZE	$\phi a1$	$\phi b1$	c1	$\phi e1$	f1	$\phi g2$	h1	i2	k	p	p3	p5	s
M0132	4.72	3.15	0.35	3.94	0.12	5.51	-	1.57	11.85	-	2.91	2.99	0.35
	5.51	3.74	0.35	4.53	0.12			1.57					0.35
	6.30	4.33	0.39	5.12	0.14			1.57					0.35
	7.87	5.12	0.39	6.50	0.14			1.57					0.43
M0232	4.72	3.15	0.39	3.94	0.12	5.51	-	1.97	12.99	-	3.54	3.58	0.26
	5.51	3.74	0.39	4.53	0.12			1.97					0.35
	6.30	4.33	0.39	5.12	0.14			1.97					0.35
	7.87	5.12	0.39	6.50	0.14			1.97					0.43
M0332	4.72	3.15	0.39	3.94	0.12	5.51	-	1.97	12.99	-	3.54	3.58	0.26
	5.51	3.74	0.39	4.53	0.12			1.97					0.35
	6.30	4.33	0.39	5.12	0.14			1.97					0.35
	7.87	5.12	0.39	6.50	0.14			1.97					0.43
M0432	5.51	3.74	0.43	4.53	0.12	7.09	-	2.36	14.84	-	3.66	4.53	0.35
	6.30	4.33	0.43	5.12	0.14			2.36					0.35
	7.87	5.12	0.43	6.50	0.14			2.36					0.43
	9.84	7.09	0.43	8.46	0.16			2.36					0.53
M0532	5.51	3.74	0.43	4.53	0.12	7.09	-	2.76	15.24	-	3.66	4.53	0.35
	6.30	4.33	0.43	5.12	0.14			2.76					0.35
	7.87	5.12	0.43	6.50	0.14			2.76					0.43
	9.84	7.09	0.43	8.46	0.16			2.76					0.53
M0632	7.87	5.12	0.43	6.50	0.16	7.09	0.57	2.76	16.06	4.57	3.31	5.12	0.43
	9.84	7.09	0.43	8.46	0.16			2.76					0.53
	11.81	9.06	0.43	10.43	0.16			2.76					0.53
M0732	7.87	5.12	0.43	6.50	0.14	8.35	-	3.15	17.80	6.10	4.33	5.51	0.43
	9.84	7.09	0.43	8.46	0.16			3.15					0.53
	11.81	9.06	0.43	10.43	0.16			3.15					0.53
M0832	11.81	9.06	0.67	10.43	0.16	9.84	-	3.94	21.26	7.09	5.12	7.17	0.53
	13.78	9.84	0.67	11.81	0.20			3.94					0.69
M0931	17.72	13.78	0.71	15.75	0.20	11.81	-	5.51	26.06	7.80	-	9.06	0.71
M1031	17.72	13.78	0.87	15.75	0.20	14.17	-	5.51	30.82	9.65	-	10.24	0.71
M1331	21.65	17.72	0.98	19.69	0.20	15.75	-	6.69	38.16	11.34	-	10.94	0.71
M1431	21.65	17.72	0.98	19.69	0.20	18.11	-	8.27	43.07	12.60	-	12.52	0.71

SIZE	High Speed Shaft						Low Speed Shaft					
	d1	L1	L14	t1	u1	w1	d	L	L12	t	u	w
M0132	0.6250	1.57	1 9/32	0.70	3/16	1/4 UNF x .63 deep	0.75	1.575	19/32	0.829	3/16	1/4 UNF x 0.63 deep
	0.7495											
M0232	0.6250	1.57	1 9/32	0.70	3/16	1/4 UNF x .63 deep	1 0.9995	1.969	19/16	1.106	1/4	1/4 UNF x 0.71 deep
	0.6245											
M0332	0.6250	1.57	1 9/32	0.70	3/16	1/4 UNF x .63 deep	1 0.9995	1.969	19/16	1.106	1/4	1/4 UNF x 0.71 deep
	0.6245											
M0432	0.6250	1.57	1 9/32	0.70	3/16	1/4 UNF x .63 deep	1.25	2.362	2	1.359	1/4	3/8 UNF x 0.86 deep
	0.6245						1.2495					
M0532	0.6250	1.57	1 9/32	0.70	3/16	1/4 UNF x .63 deep	1.375	2.756	23/8	1.507	5/16	3/8 UNF x 0.75 deep
	0.6245						1.3745					
M0632	0.6250	1.57	1 9/32	0.70	3/16	1/4 UNF x .63 deep	1.375	2.756	23/8	1.507	5/16	3/8 UNF x 0.75 deep
	0.6245						1.3745					
M0732	0.7500	1.57	1 9/32	0.83	3/16	1/4 UNF x .63 deep	1.625	3.15	23/8	1.784	3/8	5/8 UNF x 1.25 deep
	0.7495						1.624					
M0832	0.8750	1.97	1 9/32	0.96	3/16	5/16 UNF x .63 deep	2.125	3.937	23/4	2.338	1/2	3/4 UNF x 1.50 deep
	0.8745						2.124					
M0931	1.1250	2.36	2	1.23	1/4	3/8 UNF x .87 deep	2.375	4.72	311/16	2.65	0.625	3/4 UNF x 1.65 deep
	1.1245						2.374					
M1031	1.3750	3.15	2 13/32	1.51	5/16	1/2 UNF x 1.10 deep	2.875	5.51	45/8	3.20	0.75	3/4 UNF x 1.65 deep
	1.3745						2.874					
M1331	2.1250	4.33	3 13/16	2.35	1/2	3/4 UNF x 1.65 deep	3.625	6.69	515/16	4.01	0.875	1 UNF x 1.97 deep
	2.1240						3.624					
M1431	2.1250	4.33	3 13/16	2.35	1/2	3/4 UNF x 1.65 deep	4 3.999	8.27	71/2	4.44	1.00	1 UNF x 1.97 deep
	2.1240						4 3.999					

SERIES M

DIMENSIONS - QUADRUPLE REDUCTION FLANGE MOUNT

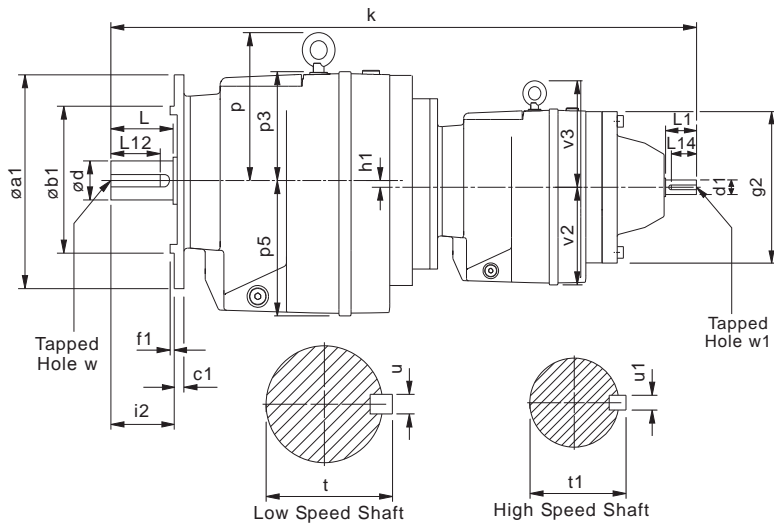

Sizes
3, 4, 5, 6, 7 and 8

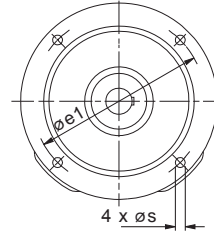

Sizes
9, 10, 13 and 14

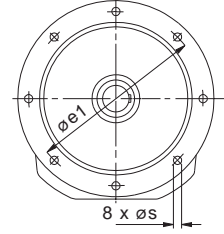

Note: Sizes 01 to 08 are also available as C-Flange (B14) mounting, please see page 82 for details

SIZE	$\phi a1$	$\phi b1$	c1	$\phi e1$	f1	$\phi g2$	h1	i2	k	p	p3	p5	s	v2	v3
M0342	4.72	3.15	0.39	3.94	0.12	5.51	-	1.97	19.80	-	3.54	3.58	0.26	2.99	-
	5.51	3.74	0.39	4.53	0.12			1.97					0.35		
	6.30	4.33	0.39	5.12	0.14			1.97					0.35		
	7.87	5.12	0.39	6.50	0.14			1.97					0.43		
M0442	5.51	3.74	0.43	4.53	0.12	5.51	-	2.36	22.48	-	3.66	4.53	0.35	3.58	-
	6.30	4.33	0.43	5.12	0.14			2.36					0.35		
	7.87	5.12	0.43	6.50	0.14			2.36					0.43		
	9.84	7.09	0.43	8.46	0.16			2.36					0.53		
M0542	5.51	3.74	0.43	4.53	0.12	5.51	-	2.76	22.87	-	3.66	4.53	0.35	3.58	-
	6.30	4.33	0.43	5.12	0.14			2.76					0.35		
	7.87	5.12	0.43	6.50	0.14			2.76					0.43		
	9.84	7.09	0.43	8.46	0.16			2.76					0.53		
M0642	7.87	5.12	0.43	6.50	0.16	5.51	-	2.76	23.70	4.57	3.31	5.12	0.43	3.58	-
	9.84	7.09	0.43	8.46	0.16			2.76					0.53		
	11.81	9.06	0.43	10.43	0.16			2.76					0.53		
M0742	7.87	5.12	0.43	6.50	0.14	5.51	-	3.15	25.16	6.10	4.33	5.51	0.43	3.58	-
	9.84	7.09	0.43	8.46	0.16			3.15					0.53		
	11.81	9.06	0.43	10.43	0.16			3.15					0.53		
M0842	11.81	9.06	0.67	10.43	0.16	7.09	-	3.94	29.57	7.09	5.12	7.17	0.53	4.53	-
	13.78	9.84	0.67	11.81	0.20			3.94					0.69		
M0941	17.72	13.78	0.71	15.75	0.20	7.09	-	5.51	32.76	7.80	-	9.06	0.71	4.53	-
M1041	17.72	13.78	0.87	15.75	0.20	8.35	-	5.51	37.64	9.65	-	10.24	0.71	5.51	6.10
M1341	21.65	17.72	0.98	19.69	0.20	8.35	-	6.69	42.40	11.34	-	10.94	0.71	5.51	6.10
M1441	21.65	17.72	0.98	19.69	0.20	8.35	-	8.27	46.93	12.60	-	12.52	0.71	5.51	6.10

SIZE	High Speed Shaft						Low Speed Shaft					
	d1	L1	L14	t1	u1	w1	d	L	L12	t	u	w
M0342	0.6250 0.6245	1.57	19/32	0.70	3/16	1/4 UNF x .63 deep	1.0000 0.9995	1.969	19/16	1.106	1/4	1/4 UNF x 0.71 deep
M0442	0.6250 0.6245	1.57	19/32	0.70	3/16	1/4 UNF x .63 deep	1.2500 1.2495	2.362	2	1.359	1/4	3/8 UNF x 0.86 deep
M0542	0.6250 0.6245	1.57	19/32	0.70	3/16	1/4 UNF x .63 deep	1.3750 1.3745	2.756	23/8	1.507	5/16	3/8 UNF x 0.75 deep
M0642	0.6250 0.6245	1.57	19/32	0.70	3/16	1/4 UNF x .63 deep	1.3750 1.3745	2.756	23/8	1.507	5/16	3/8 UNF x 0.75 deep
M0742	0.6250 0.6245	1.57	19/32	0.70	3/16	1/4 UNF x .63 deep	1.6250 1.6240	3.15	23/8	1.784	3/8	5/8 UNF x 1.25 deep
M0842	0.7500 0.7495	1.57	19/32	0.83	3/16	1/4 UNF x .63 deep	2.1250 2.1240	3.937	23/4	2.338	1/2	3/4 UNF x 1.50 deep
M0941	0.7500 0.7495	1.57	19/32	0.83	3/16	1/4 UNF x .63 deep	2.3750 2.3740	4.72	311/16	2.65	0.625	3/4 UNF x 1.65 deep
M1041	0.8750 0.8745	1.97	19/32	0.96	3/16	5/16 UNF x .63 deep	2.875 2.874	5.51	45/8	3.20	0.75	3/4 UNF x 1.65 deep
M1341	0.8750 0.8745	1.97	19/32	0.96	3/16	5/16 UNF x .63 deep	3.625 3.624	6.69	515/16	4.01	0.875	1 UNF x 1.97 deep
M1441	0.8750 0.8745	1.97	19/32	0.96	3/16	5/16 UNF x .63 deep	4.000 3.999	8.27	71/2	4.44	1.00	1 UNF x 1.97 deep

SERIES M

DIMENSIONS

C-FLANGE (B14) MOUNTING

Column 9 Entry

- E C-Flange (B14) Mounting (For sizes M01 to M08 only)
- V Base and C-Flange (B14) Mounting (non standard - special orders only)

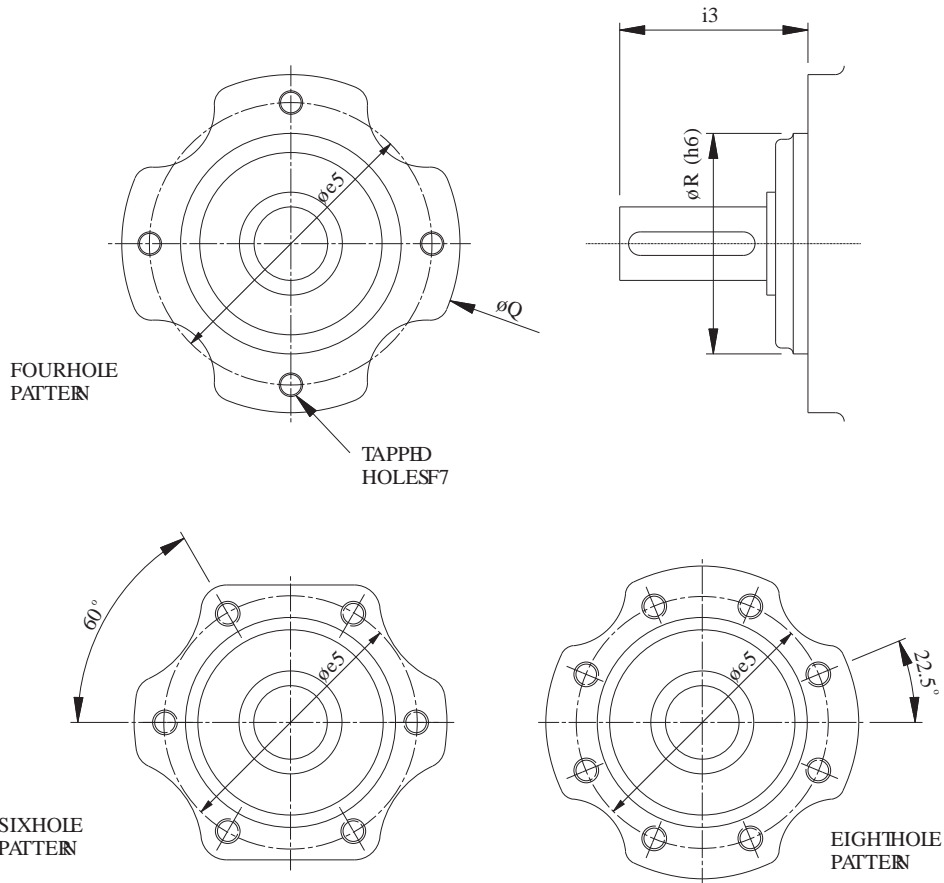

2, 3, 4 & 5 Stage Units

SIZE	$\phi e5$	F7	i3	ϕQ	ϕR
M01	2.95	4 Holes M8 x 1.25 12 Deep	2.13	3.86	2.05
M02 / M03	3.78	4 Holes M8 x 1.25 15 Deep	2.44	4.53	2.95
M04 / M05	4.13	4 Holes M12 x 1.75 21 Deep	2.91 / 3.31	5.12	3.35
M06 / M07	4.88	6 Holes M12 x 1.75 21 Deep	3.31 / 3.70	5.98	4.02
M08	6.69	8 Holes M12 x 1.75 21 Deep	4.72	7.68	5.71

SERIES M

THERMAL POWER RATING

Thermal Ratings (HP)

Thermal ratings are a measure of the units ability to dissipate heat, if they are exceeded the lubricant may break down resulting in premature gear failure.

Thermal ratings are based on an ambient temperature of 68°F, when units are to operate at other ambient temperatures the thermal HP ratings must be multiplied by the following factors

Unit Size	Ambient Temperature °F							
	-4	14	32	50	68	86	104	122
All units	1.57	1.43	1.29	1.14	1	0.86	0.71	0.5

Thermal Power (HP) - Two Stage Units

Overall Ratios	Type of Cooling	Input Rev/ min	Unit Size											
			M01	M02	M03	M04	M05	M06	M07	M08	M09	M10	M13	M14
1.4 to 5.6	Units with no additional cooling	3500	Consult Application Engineering											
		1750	5.5	8.0	8.0	13.2	13.2	15.3	19.3	29.5	41.9	56.5	71.7	97.9
		1160	5.3	7.6	7.6	12.6	12.6	14.6	18.4	28.2	40.0	54.0	68.5	93.5
		875	5.1	7.4	7.4	12.2	12.2	14.2	17.9	27.3	38.8	52.3	66.3	90.6
6.3 & over	Units with no additional cooling	3500	3.8	5.5	5.5	9.2	9.2	10.7	13.5	20.7	29.3	39.5	50.1	68.4
		1750	5.4	7.8	7.8	13.0	13.0	15.0	19.0	29.1	41.3	55.6	70.6	96.3
		1160	5.2	7.4	7.4	12.4	12.4	14.3	18.1	27.8	39.4	53.1	67.4	92.0
		875	5.0	7.2	7.2	12.0	12.0	13.9	17.6	26.9	38.2	51.4	65.3	89.1
1.4 to 5.6	Units with fan cooling	3500	N/A	N/A	N/A	N/A	N/A	N/A	N/A	N/A	N/A	N/A	N/A	N/A
		1750	-	-	-	-	-	-	43.4	66.4	94.3	127.1	161.3	220.3
		1160	-	-	-	-	-	-	36.2	55.3	78.6	105.9	134.4	183.6
		875	-	-	-	-	-	-	31.4	47.9	68.1	91.8	116.5	159.1
6.3 & over	Units with fan cooling	3500	-	-	-	-	-	-	N/A	N/A	N/A	N/A	N/A	N/A
		1750	-	-	-	-	-	-	42.8	65.5	92.9	125.1	158.9	216.7
		1160	-	-	-	-	-	-	35.6	54.6	77.4	104.3	132.4	180.6
		875	-	-	-	-	-	-	30.9	47.3	67.1	90.4	114.7	156.5

Note: When checking thermal capacities use actual load required to be transmitted, not rating of prime mover.

SERIES M

FAN COOLED UNITS

Column 10 Entry

For reducer fan kit modules enter **S** in column 10
 or if used in conjunction with a reducer backstop module kit

Y
Z

CW rotation
 CCW rotation

Dimensions of Fan Cooled Units

Double Reduction Units

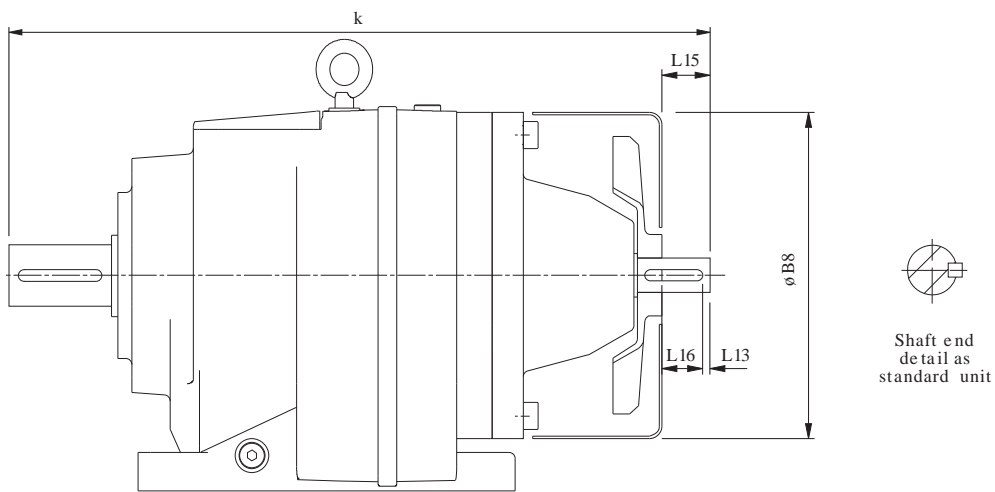

Unit Size	ØB8	k	L15	L16
M0722	8.86	17.32	1.38	1.28
M0822	10.43	21.85	1.77	2.00
M0921	12.60	25.98	2.56	2.40
M1021	14.96	30.79	3.74	3.69
M1321	16.54	35.71	3.35	3.81
M1421	18.90	40.24	3.35	3.81

SERIES M

REDUCER BACKSTOP MODULE

The reducer units listed below can be fitted with an internal backstop, this has no effect of the external unit size. The backstop device incorporates high quality centrifugal lift off sprags which are wear free above the lift off speed (n min). To ensure correct operation input speed must exceed lift off speed.

Suitable for ambient temperature -40°F to + 122°F

Column 10 Entry

For reducer backstop modules enter W for CCW rotation (or Z if used in conjunction with a fan kit)
 X for CW rotation (or Y if used in conjunction with a fan kit)

Unit Size	Lift off Speed ('n' min) (at inputshaft) (rev/min)	Rated Locking Torque ('T max') (at inputshaft) (lb.in)
M0422	800	885
M0522	800	885
M0622	800	885
M0722	670	1504
M0732	800	885
M0822	670	2655
M0832	670	1504
M0921	620	8320
M0931	670	2655
M1021	550	11152
M1031	670	2655
M1321	550	21242
M1331	550	21242
M1421	550	21242
M1431	550	21242

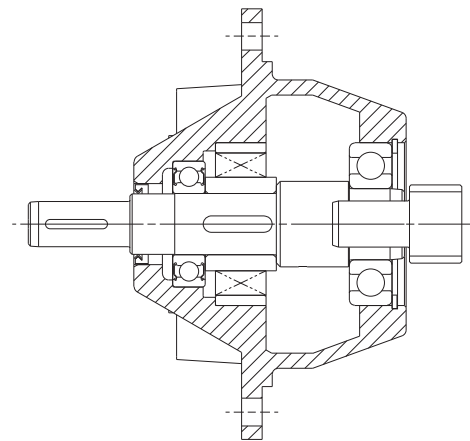

Rotation of outputshaft must be specified when ordering as viewed from the outputshaft end (as shown in the diagram)

- | | | | | |
|----|---|---------------|---|---------------|
| CW | - | Free Rotation | - | Clockwise |
| | | Locked | - | Anticlockwise |
| AC | - | Free Rotation | - | Anticlockwise |
| | | Locked | - | Clockwise |

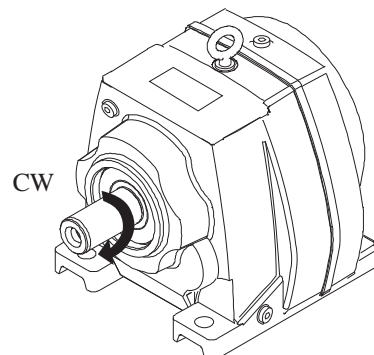

SERIES M

SHIPPING SPECIFICATION

Basemount Units Weight (Pounds)

Total Weight of Gearmotor = Gearbox Weight plus Motor weight

UNIT SIZE & NO OF REDUCTIONS		M0122	M0132	M0222	M0232	M0322	M0332	M0342	M0352	M0422	M0432	M0442	M0452	M0522	M0532	M0542	M0552	M0622	M0632	M0642	M0652
Mass lb's Reducer Unit		18	19	26	29	26	29	47	48	49	50	73	75	49	50	73	75	59	60	88	90
MOTORIZED NEMA Unit Without Motor	56C	20	21	29	32	29	32	50	51	48	49	72	74	48	49	72	74	58	59	87	89
	143-145TC	20	21	29	32	29	32	50	51	48	49	72	74	48	49	72	74	58	59	87	89
	182-184TC	23	24	31	34	32	34	53	54	63	64	87	89	63	64	87	89	73	74	102	104
	213-215TC	-	-	-	-	-	-	-	-	63	-	-	-	63	-	-	-	-	-	-	-

UNIT SIZE & NO OF REDUCTIONS		M0722	M0732	M0742	M0752	M0822	M0832	M0842	M0852	M0921	M0931	M0941	M0951	M1021	M1031	M1041	M1051	M1321	M1331	M1341	M1351	M1421	M1431	M141	M1451
Mass lb's Reducer Unit		84	86	106	108	148	163	212	212	252	272	309	309	375	395	450	460	547	596	615	617	794	893	871	873
MOTORIZED NEMA Unit Without Motor	56C	86	88	108	110	156	146	212	210		280	308	330			448	492			779	759			948	938
	143-145TC	86	88	108	110	156	146	212	210		280	308	330			448	492			779	759			948	938
	182-184TC	99	101	121	123	156	159	225	225	248	280	325	346	352	394	461	505	510	581	779	772		833	948	951
	213-215TC	99				156	159	225	225	248	280	325	346	352	394	461	505	510	581	779	772	746	833	948	951
	254-256TC	99				156				264	280			371	410			515	586			746	838		
	284-286TC									269				376	415			515	586			751	838		
	324-326TC									273				380	419			521	592			756	844		
	364-365TC																	661	732			889	894		
	404-405TC																	675	746			896	998		

NEMA FRAME	Motor Weight - Pounds
56C	25
143TC	30
145TC	40
182TC	55
184TC	77
213TC	115
215TC	160
254TC	285
256TC	310
284TC	430
286TC	445
324TC	525
326TC	650
364TC	715
365TC	840
404TC	1060
405TC	1200

SERIES M

SHIPPING SPECIFICATION

Flangemount Units Weight (Pounds)

Total Weight of Gearmotor = Gearbox Weight plus Motor weight

UNIT SIZE & NO OF REDUCTIONS		M0122	M0132	M0222	M0232	M0322	M0332	M0342	M0352	M0422	M0432	M0442	M0452	M0522	M0532	M0542	M0552	M0622	M0632	M0642	M0652
Mass lb's Reducer Unit		18	19	26	29	26	29	47	48	49	50	73	75	49	50	73	75	59	60	88	90
MOTORIZED NEMA Unit Without Motor	56C	21	22	29	35	31	35	52	53	50	51	76	78	52	51	77	79	62	63	92	94
	143-145TC	21	22	29	35	31	35	52	53	50	51	76	78	52	51	77	79	62	63	92	94
	182-184TC	24	25	31	35	34	37	55	56	65	66	91	93	67	66	92	94	77	78	107	109
	213-215TC	-	-	-	-	-	-	-	-	65	-	-	-	67	-	-	-	-	-	-	-

UNIT SIZE & NO OF REDUCTIONS		M0722	M0732	M0742	M0752	M0822	M0832	M0842	M0852	M0921	M0931	M0941	M0951	M1021	M1031	M1041	M1051	M1321	M1331	M1341	M1351	M1421	M1431	M141	M1451
Mass lb's Reducer Unit		84	86	106	108	148	163	212	212	252	272	309	309	375	395	450	460	547	596	615	617	794	893	871	873
MOTORIZED NEMA Unit Without Motor	56C	90	92	112	114	165	155	221	219		287	315	337			457	501			772	752			904	894
	143-145TC	90	92	112	114	165	155	221	219		287	315	337			457	501			772	752			904	894
	182-184TC	103	105	125	127	165	168	234	234	255	287	332	353	361	403	470	514	503	574	772	765		789	904	907
	213-215TC	103	105			165	168	234	234	255	287	332	353	361	403	470	514	503	574	772	765	702	789	904	907
	254-256TC	103				165				271	287			380	419			508	579			702	794		
	284-286TC									276				385	424			508	579			707	794		
	324-326TC									280				389	428			514	585			712	800		
	364-365TC																	654	725			845	850		
	404-405TC																	668	739			852	954		

NEMA FRAME	Motor Weight - Pounds
56C	25
143TC	30
145TC	40
182TC	55
184TC	77
213TC	115
215TC	160
254TC	285
256TC	310
284TC	430
286TC	445
324TC	525
326TC	650
364TC	715
365TC	840
404TC	1060
405TC	1200

IMPORTANT

Product Safety Information

General - The following information is important in ensuring safety. It **must** be brought to the attention of personnel involved in the selection of the equipment, those responsible for the design of the machinery in which it is to be incorporated and those involved in its installation, use and maintenance.

The equipment will operate safely provided it is selected, installed, used and maintained properly. As with any power transmission equipment **proper precautions must** be taken as indicated in the following paragraphs, to ensure safety.

Potential Hazards - these are **not** necessarily listed in any order of severity as the degree of danger varies in individual circumstances. It is important therefore that the list is studied in its entirety:-

- 1) Fire/Explosion
 - (a) Oil mists and vapour are generated within gear units. It is therefore dangerous to use naked lights in the proximity of gearbox openings, due to the risk of fire or explosion.
 - (b) In the event of fire or serious overheating (over 300 °C), certain materials (rubber, plastics, etc.) may decompose and produce fumes. Care should be taken to avoid exposure to the fumes, and the remains of burned or overheated plastic/rubber materials should be handled with rubber gloves.
- 2) Guards - Rotating shafts and couplings must be guarded to eliminate the possibility of physical contact or entanglement of clothing. It should be of rigid construction and firmly secured.
- 3) Noise - High speed gearboxes and gearbox driven machinery may produce noise levels which are damaging to the hearing with prolonged exposure. Ear defenders should be provided for personnel in these circumstances. Reference should be made to the Department of Employment Code of Practice for reducing exposure of employed persons to noise.
- 4) Lifting - Where provided (on larger units) only the lifting points or eyebolts must be used for lifting operations (see maintenance manual or general arrangement drawing for lifting point positions). Failure to use the lifting points provided may result in personal injury and/or damage to the product or surrounding equipment. Keep clear of raised equipment.
- 5) Lubricants and Lubrication
 - (a) Prolonged contact with lubricants can be detrimental to the skin. The manufacturer's instruction must be followed when handling lubricants.
 - (b) The lubrication status of the equipment must be checked before commissioning. Read and carry out all instructions on the lubricant plate and in the installation and maintenance literature. Heed all warning tags. Failure to do so could result in mechanical damage and in extreme cases risk of injury to personnel.
- 6) Electrical Equipment - Observe hazard warnings on electrical equipment and isolate power before working on the gearbox or associated equipment, in order to prevent the machinery being started.
- 7) Installation, Maintenance and Storage
 - (a) In the event that equipment is to be held in storage, for a period exceeding 6 months, prior to installation or commissioning, application engineering must be consulted regarding special preservation requirements. Unless otherwise agreed, equipment must be stored in a building protected from extremes of temperature and humidity to prevent deterioration.
The rotating components (gears and shafts) must be turned a few revolutions once a month (to prevent bearings brinelling).
 - (b) External gearbox components may be supplied with preservative materials applied, in the form of a "waxed" tape overwrap or wax film preservative. Gloves should be worn when removing these materials. The former can be removed manually, the latter using white spirit as a solvent.

Preservatives applied to the internal parts of the gear units do not require removal prior to operation.
 - (c) Installation must be performed in accordance with the manufacturer's instructions and be undertaken by suitably qualified personnel.
 - (d) Before working on a gearbox or associated equipment, ensure that the load has been removed from the system to eliminate the possibility of any movement of the machinery and isolate power supply. Where necessary, provide mechanical means to ensure the machinery cannot move or rotate. Ensure removal of such devices after work is complete.
 - (e) Ensure the proper maintenance of gearboxes in operation. Use only the correct tools and approved spare parts for repair and maintenance. Consult the Maintenance Manual before dismantling or performing maintenance work.
- 8) Hot Surfaces and Lubricants
 - (a) During operation, gear units may become sufficiently hot to cause skin burns. Care must be taken to avoid accidental contact.
 - (b) After extended running the lubricant in gear units and lubrication systems may reach temperatures sufficient to cause burns. Allow equipment to cool before servicing or performing adjustments.
- 9) Selection and Design
 - (a) Where gear units provide a backstop facility, ensure that back-up systems are provided if failure of the backstop device would endanger personnel or result in damage.
 - (b) The driving and driven equipment must be correctly selected to ensure that the complete machinery installation will perform satisfactorily, avoiding system critical speeds, system torsional vibration, etc.
 - (c) The equipment must not be operated in an environment or at speeds, powers, torques or with external loads beyond those for which it was designed.
 - (d) As improvements in design are being made continually the contents of this catalogue are not to be regarded as binding in detail, and drawings and capacities are subject to alterations without notice.

The above guidance is based on the current state of knowledge and our best assessment of the potential hazards in the operation of the gear units.

Any further information or clarification required may be obtained by contacting an Application Engineer.

SERIES M

NOTES

CONTACT US

AUSTRALIA

Radicon Transmission (Australia) PTY Ltd

Australia
Please refer to web site

EUROPE

Benzler TBA BV

Jachthavenweg 2
NL-5928 NT Venlo

Austria
Tel: +43 7 229 618 91
Fax: +43 7 229 618 84

Germany
Tel: 0800 350 40 00
Fax: 0800 350 40 01

Italy
Tel: +39 02 824 3511

Netherlands & the rest of Europe
Tel: +31 77 324 59 00
Fax: +31 77 324 59 01

DENMARK

Benzler Transmission A/S

Dalager 1
DK-2605 Brøndby,
Denmark

Tel: +45 36 34 03 00
Fax: +45 36 77 02 42

FINLAND

Oy Benzler AB

Vanha Talvitie 3C
FI-00580 Helsingfors,
Finland

Tel: +358 9 340 1716
Fax: +358 10 296 2072

INDIA

Elecon. Engineering Company Ltd.

Anand Sojitra Road
Vallabh Vidyanagar
388120 Gujarat
India

Tel: +91 2692 236513
Fax: +91 2692 227484

SWEDEN & NORWAY

AB Benzlers

Porfyrgatan
254 68 Helsingborg
Sweden

Tel: +46 42 18 68 00
Fax: +46 42 21 88 03

THAILAND

Radicon Transmission (Thailand) Ltd

700/43 Moo 6
Amata Nakorn Industrial Estate
Tumbol Klontumru
Muang,
Chonburi
20000
Thailand

Tel: +66 3845 9044
Fax: +66 3821 3655

UNITED KINGDOM

Radicon Transmission UK Ltd

Unit J3
Lowfields Business Park,
Lowfields Way, Elland
West Yorkshire, HX5 9DA

Tel: +44 1484 465 800
Fax: +44 1484 465 801

USA

Radicon USA Transmission Ltd

1599 Lunt Avenue
Elk Grove Village
Chicago
Illinois
60007
USA

Tel: +1 847 593 9910
Fax: +1 847 593 9950

www.benzlers.com

www.radicon.com

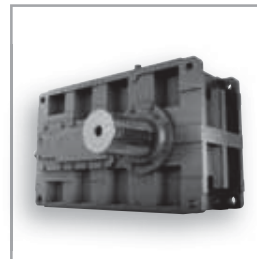
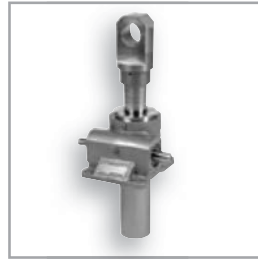

benzlers☼

radicon☼

Benzlers

Denmark +45 36 34 03 00

Finland +358 9 340 1716

Germany +49 800-350 4000

Sweden +46 42 186800

The Netherlands +31 77 324 59 00

www.benzlers.com

Radicon

Thailand +66 3845 9044

United Kingdom +44 (0) 1484 465 800

USA +1 847 593 9910

www.radicon.com