



Omega Elastomeric Couplings

(Inch)



Table Of Contents

DESCRIPTION	PAGE
Rexnord® Omega® Elastomeric Couplings	3
Selection Procedures	4
Typical Service Factors – Motor and Turbine Driven Equipment	5
Ordering Instructions	6
Tapered Bores	6
Installation	7
CLOSE-COUPLED COUPLINGS	
Omega Close-Coupled Design with Straight Bore Hubs	8
Omega Close-Coupled Design with Compression Bushed Hubs	9
SPACER COUPLINGS	
Omega Spacer Design with Straight Bore Hubs	10
Omega Spacer Design with Compression Bushed Hubs	11
Adjustability	12
Omega Extended Spacer Coupling	13
ADDITIONAL COUPLINGS AND TECHNICAL DATA	
Mill Motor Couplings	14
Special Designs	15
Bore Specification	16
Finished Stock Bore Hub Part Numbers	16
Coupling Selection	17
Omega Couplings Interchange	17

Rexnord Omega Elastomeric Couplings

OEM Performance and Coverage

The unique split-in-half flex element and reversible hubs significantly decrease total costs by reducing inventory and assembly time.

Rexnord Omega couplings are non-lubricated, material-flexing couplings utilizing a specially formulated polyurethane material engineered for maximum durability, strength and fatigue resistance.

The Rex® Omega HSU coupling (green) is specifically designed for hot and humid conditions.

Rexnord is the leading coupling provider in the industry with a full-line of available solutions supported by trained customer service and application engineering professionals focused only on our coupling product line. For more information, contact your local Rexnord account executive.

Features and Benefits

Torsionally Soft Flex Element

Split-in-Half Design

Radial Bolting

Polyurethane-to-Metal Bond

Interchangeable Hubs

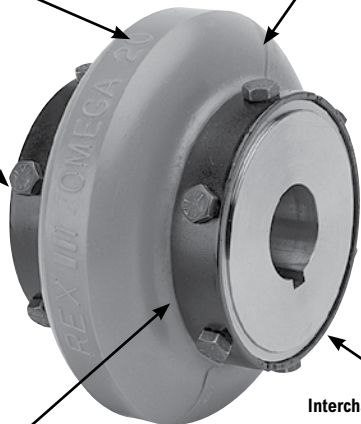

- Split-in-half flex element design for simplified assembly and disassembly
- Interchangeable hubs allow for reduced inventory
- High-misalignment capacity accommodates unavoidable misalignment with low reactionary forces
- Torsionally soft flex element cushions shock loads and vibration, extending equipment life
- Polyurethane flex element does not require lubrication
- Polyurethane-to-metal bond eliminates assembly and slippage problems associated with mechanically clamped designs
- Our selection software makes choosing the right coupling a snap
- Rexnord field specialists are locally based experts available to support key end-users
- The Rexnord Omega HSU coupling (green) is specifically designed for hot and humid environments. In addition, the HSU material performs well in caustic and acidic environments. Consult Rexnord engineering for your application.



Rexnord Omega couplings operate in either horizontal or vertical applications without any additional components.

Ease of installation, ease of maintenance and visual inspection make these couplings a must for many applications such as this mash cooker in a brewery. Never operate a coupling without an OSHA approved guard.

Selection Procedures

- Determine HP/100 RPM:**
$$\text{HP/100 RPM} = \frac{\text{Horsepower} \times 100}{\text{RPM}}$$
- Determine Service Factor:**
Select the proper Service Factor from Table on **page 5**. If not listed, see Load Classification Table.
Remember to consider both driver and driven equipment and temperature requirements.
- Multiply HP/100 by the service factor to get equivalent HP/100 RPM.**
- Select the Coupling Size:**
From **Table 1**, with a rating equal to or greater than the equivalent HP/100 RPM determined in Step 3.
- Check Limiting Conditions:**
Be sure that the operating speed of the coupling does not exceed maximum RPM listed on **pages 8-11**.
- Select Desired Hub Type:**
Select desired hub type and check maximum allowable coupling bore on **page 17**.

OR

- Determine Operating Torque:**
$$\left(\frac{63,000 \times \text{HP}}{\text{RPM}} \right)$$
- Multiply by Service Factor:**
Select the proper Service Factor from Table on **page 5**.
- Select the Coupling Size:**
Select coupling size from **Table 2** with a capacity equal to or greater than determined in Step 2.
- Follow Steps 5 & 6 Above**

Service Factors

Service Factors (S.F.) are a means of classifying different equipment and applications into various load classifications. Due to variations in application of equipment, service factors are used to adjust equipment ratings to accommodate for variable loading conditions. This is a general guide. More specific factors are given on **page 5**.



	Load Classifications	Service Factors
	Continuous service and running loads vary only slightly.	1.0
	Torque loading varies during operation of the equipment.	1.5
	Torque loading varies during operation, frequent stop/start cycles are encountered.	2.0
	For shock loading and substantial torque variations.	2.5
	For heavy shock loading or light reversing drives.	3.0
	Reversing torque loads do not necessarily mean reversal of rotation. Depending upon severity of torque reversal, such loads must be classified between "medium" and "extreme."	Consult Rexnord

Table 1

Size		Equivalent HP/100 RPM
Standard	Spacer	
E2	ES2	0.3
E3	ES3	0.58
E4	ES4	0.88
E5	ES5	1.48
E10	ES10	2.3
E20	ES20	3.65
E30	ES30	5.79
E40	ES40	8.85
E50	ES50	12.14
E60	ES60	19.84
E70	ES70	35.12
E80	ES80	62.7
E100	NA	135
E120	NA	270
E140	NA	540

Table 2

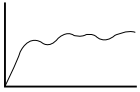
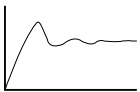
Torque Capacity			
Size	Continuous Torque (lb-in)	Size	Continuous Torque (lb-in)
2	190	40	5,500
3	365	50	7,650
4	550	60	12,500
5	925	70	22,125
10	1,450	80	39,500
20	2,300	100	85,050
30	3,650	120	170,100
		140	340,200

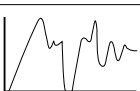
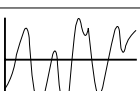
Peak torque capacity of element is 250% of above continuous ratings.

Omega Element Temperature Range (Ambient) ①	
-40°F	-40°C
to	
+200°F	+93°C

High Temperature Service Factor Adjustment ①	
Ambient Temp.	S.F. Adjust.
+150°F (66°C)	0.25
+165°F (74°C)	0.50
+180°F (82°C)	0.75
+200°F (93°C)	1

① Added to application service factor.

The service factor adjustment for high temperature is in addition to the service factor consideration for the driver and driven equipment. However, if high temperatures are typical for a specific application, maximum temperature consideration is incorporated into the "typical" service factor listing on **page 5**, i.e., steel mill runout tables.

Typical Service Factors – Motor and Turbine Driven Equipment ^①

General Application	Typical Service Factor	Industry Application	Typical Service Factor	Industry Application	Typical Service Factor
AGITATORS		AGGREGATE PROCESSING, CEMENT		PULP & PAPER MILLS	
Vertical and Horizontal Screw Propeller, Paddle.....	1.5	Concrete Mixers	2.0	Agitator.....	1.5
BLOWERS		Crushers, Ore or Stone.....	3.0	Baking Drum.....	3.0
Centrifugal.....	1.0	Dryer, Rotary.....	2.0	Beater and Pulper.....	2.0
Lobe or Vane.....	1.5	Grizzly.....	3.0	Bleacher.....	1.0
CAR DUMPER AND PULLER	2.0	Hammermill.....	2.5	Calendar.....	2.5
COMPRESSORS		Mining Kilns.....	2.5	Chipper.....	3.5
Centrifugal.....	1.0	Tube, Rod and Ball Mills.....	2.5	Couch, Cylinder Dryer.....	2.0
Lobe or Vane.....	1.5	Tumbling Mill or Barrel.....	2.0	Felt Stretcher.....	1.0
Screw.....	1.25	BREWERY AND DISTILLING		Fourdrinier.....	2.0
Reciprocating..... ^①	①	Bottling and Can Filling Machinery, Brew Kettle, Cooker, Mash Tub.....	1.0	Jordan.....	2.5
CONVEYORS		Scale Hopper (frequent peaks).....	2.0	Press.....	2.5
Apron, Assembly, Belt, Chain, Flight, Oven.....	1.5	FOOD INDUSTRY		Pulp Grinder.....	2.5
Reciprocating..... ^②	②	Bottle and Can Filling.....	1.0	Stock Chests.....	1.5
Screw.....	1.25	Cereal Cooker.....	1.0	Stock Pump	
CRANES AND HOISTS		Dough Mixer, Meat Grinder.....	2.0	Centrifugal.....	1.25
Main Hoist – Medium Duty.....	2.0	LUMBER INDUSTRY		Reciprocating.....	2.5
Main Hoist – Heavy Duty.....	2.5	Band Resaw, Circular Resaw.....	2.0	Suction Roll.....	2.5
Skip Hoist.....	2.0	Edger, Head Rig, Hog, Log Haul.....	2.5	Winder.....	2.0
Bridge, Travel or Trolley.....	2.0	Planer.....	2.0	RUBBER INDUSTRY	
DREDGES		Rolls, Non-Reversing.....	2.0	Banbury Mixer.....	3.0
Cable Reel, Conveyor.....	2.0	Rolls, Reversing.....	2.5	Calendar.....	2.5
Cutter Head Drive, Jig Drive.....	3.0	Sawdust Conveyor.....	1.5	Cracker, Mix Mill, Plasticator, Refiner, Sheeter, Tire Building Machine.....	2.0
Pump, Screen, Drive, Stacker, Utility Winch.....	2.0	Slab Conveyor, Sorting Table.....	2.0	Tire and Tube Press Opener.....	1.0
DYNAMOMETER	1.0	OIL INDUSTRY		Tiber and Strainer.....	2.0
ELEVATORS		Chiller.....	1.0	Warming Mill.....	2.5
Bucket, Freight.....	2.5	POWER INDUSTRY		Washer.....	3.0
EXCITER, GENERATOR	1.0	Ash Handling Conveyors.....	1.5	STEEL INDUSTRY	
EXTRUDER, PLASTIC	2.0	Baghouse Air Handling Fans.....	1.5	Coilers.....	2.0
FANS		Ball Mill.....	2.5	Draw Benches.....	2.0
Centrifugal.....	1.0	Belt Conveyors.....	1.5	Edger Drives.....	2.0
Cooling Tower.....	2.0	Circulating pumps (centrifugal).....	1.0	Reel Drives.....	2.0
Forced Draft and Induced Draft.....	1.5	Coal Grinders and Crushers.....	2.5	Runout Tables (Non-Reversing).....	3.0
Large Mine.....	2.0	Coal Pulverizers and Hammermills.....	2.5	Runout Tables (Reversing).....	4.5
Propeller.....	1.5	Cooling Tower Fans.....	2.0	Soaking Pit Cover Drives.....	3.0
GENERATORS		FGD Slurry Pumps (centrifugal).....	1.0	Tube Conveyor Rolls.....	2.5
Even Load.....	1.0	Forced Draft Fan and Induced Draft Fan.....	1.5	Wire Drawing.....	2.0
Hoist or Railway Service.....	2.0	Primary Air, Recycling Fans.....	1.5	TEXTILE MILLS	
Welder Load.....	2.5	Traveling Water Screens.....	1.0	Batcher, Calendar, Card Machine, Dry Can.....	2.0
PRINTING PRESS	2.0			Dyeing Machinery.....	1.0
PUMPS				Loom.....	2.0
Centrifugal.....	1.0			Mangle, Napper, Soaper.....	1.5
Positive Displacement.....	1.5			Spinner, Tenter Frame.....	2.0
Gear, Lobe, Vane.....	1.5				
Reciprocating..... ^②	②				
Progressive Cavity.....	1.25				
Peristaltic.....	1.5				
Screw.....	1.25				
SCREENS					
Air Washing.....	3.0				
Grizzly.....	1.0				
Coal and Sand (Rotary).....	2.0				
Vibrating.....	5.0				
SEWAGE DISPOSAL EQUIPMENT	1.5				
STOKER	1.5				

① The Service Factors listed are intended only as a general guide and for smooth power sources such as electric motors. For reciprocating prime movers, such as diesel or gas engines, add the following service factor:

For 8 or more cylinders, add 0.5

For 6 cylinders, add 1.0

For 4 cylinders, add 1.5

For less than 4 cylinders, consult Rexnord

If both driver and driven equipment are reciprocating, consult Rexnord.

Add 0.5 to service factor if drive is a hydraulic motor.

Omega couplings are not recommended for turbine drives if the coupling cannot be protected from steam leakage or from speeds in excess of the coupling's published speed rating (**pages 8-11**).

② Consult Rexnord Engineering.

IMPORTANT NOTE: The coupling selection criteria is intended for the determination of the coupling and style only. It is also recommended that the system be analyzed for torsional and lateral stability using the specific coupling mass-elastic data available from Rexnord. This analysis is the responsibility of the user since the coupling is only a single component in the system.

CAUTION: In the drive systems sensitive to axial movement (i.e. sleeve bearing equipment), it may be necessary to limit axial force and/or displacement. Consult Rexnord for the proper installation procedure.

Ordering Instructions

Standard and Spacer Couplings

When ordering a complete coupling, specify size/type of element and hubs (two hubs per complete coupling).

Options Include

Element

[E2	– E140]	close-coupled
[ES2-R	– ES80]	spacer

Hub

[2HRB	– 140HRB]	straight hub – rough bore
[2HSB	– 60HSB]	straight hub – stock bore (specify bore size from table on page 16)
[2HCB	– 140HCB]	straight hub – custom bore (specify bore and keyway)
[4HQD	– 140HQD]	hub – QD (bushing not included)
[3HTL	– 140HTL]	hub – Taper-Lock® (bushing not included)
[10HMM	– 140HMM]	straight hub – mill motor (specify mill motor number, rough or custom bore)

Tapered Bores

1. Drawing of HUB showing complete bore and keyway details.
— OR —
2. Drawing of SHAFT with dimensions shown below, allowing Rexnord to bore hubs to suit.

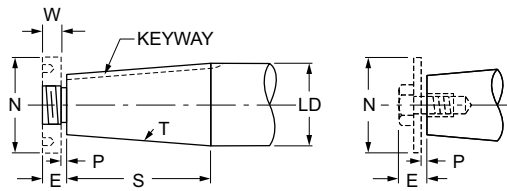

- (LD) Large diameter, specify in decimals.
- (S) Length of taper, measure parallel to shaft centerline.
- (T) Taper per foot, difference in diameter in one foot length.
- (P) Clearance space for drawing hub up on tapered shaft. Usually 1/8" or 1/4", depending on shaft size and taper.

Keyway: Width, Depth.

NOTE: Specify if keyway is parallel to taper or if parallel to shaft centerline.
Specify depth at large diameter of taper if keyway is parallel to shaft centerline.

Order Example

Complete E50 close-coupled coupling with one finished bore 2-1/8" hub w/standard keyway and one QD hub less bushing. Order description:
1 ea. E50 element
1 ea. 50HSB – 2-1/8" – std.
1 ea. 50 HQD – steel

With connected equipment in fixed position, the following additional information is necessary:

Dimensions "V" and "X" must be given when one or both connected machines are fixed on their bases. Advise if dimension "X" is fixed, or if variable, between what limits.

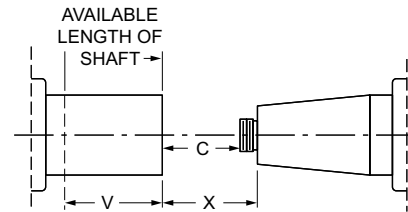

A fixed "X" dimension may require altered or special coupling hubs. Often the straight bored hub can be positioned on its shaft, allowing the use of a standard coupling. See illustrations below.

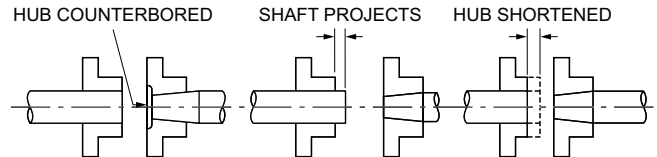

Consult AGMA Standard 9002 "Taper Bores for Flexible Couplings" for new applications.

Installation

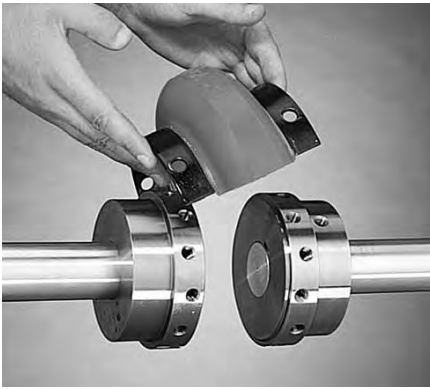

Mount one hub to shaft, leave other hub loose for adjustment of spacing.

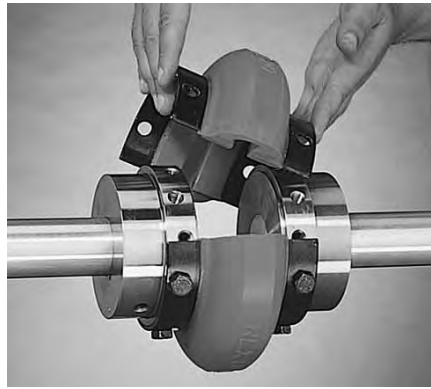

Place half of the Rexnord Omega element around hubs and secure with self-locking cap screws. Omega element will space the other hub. Now secure the other hub.

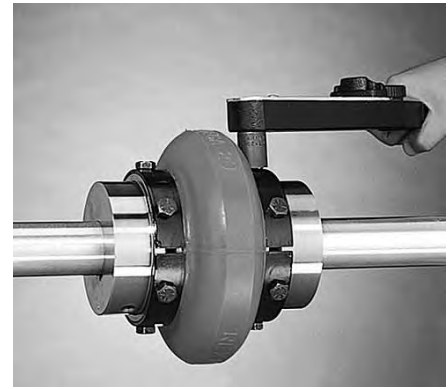

Mount other half of the Omega element. Tighten all cap screws to recommended torques below and installation is done. Refer to the installation instruction for further details.

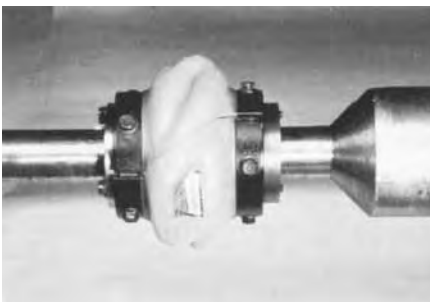

Severe static testing ($5 \times$ rating) shows element flexibility, rugged design and positive adhesive bond to the metal shoes.

Tested Tough

Rigorous testing demonstrates that the Rexnord Omega coupling protects connected equipment from the damaging effects of misalignment, vibration and gross overload. Where other coupling designs might allow equipment damage, the super flexible element of Rexnord Omega couplings minimizes the reactionary forces on equipment bearings under severe misalignment conditions and reduces the effects of excessive shock overloads.

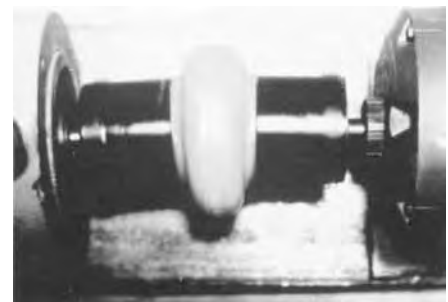

Demonstrates coupling's ability to accept severe misalignment.

Omega Coupling Allowable Misalignment

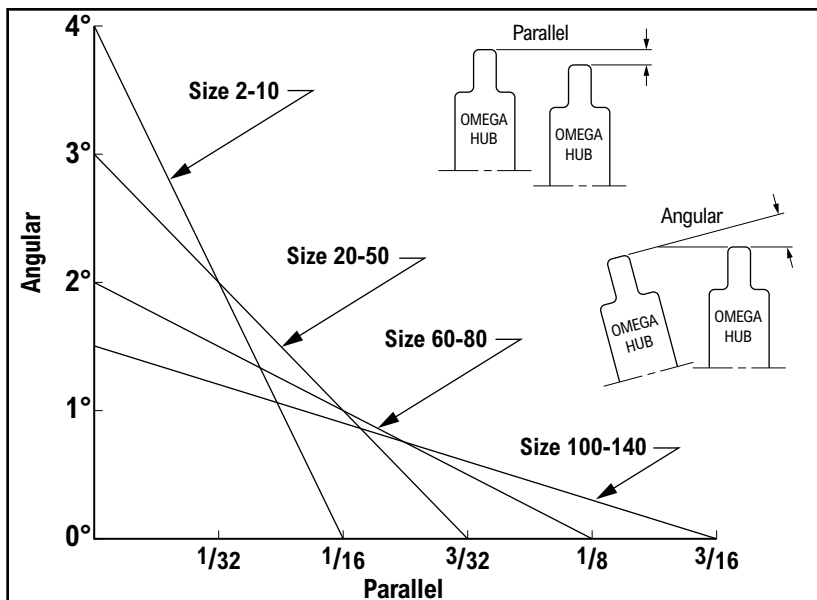

NOTE: Any combination of parallel and angular misalignment which falls under the triangle will not cause a premature fatigue failure of the flexible element in normal use.

IMPORTANT

Recommended Cap Screw Torque for Proper Installation

Coupling Size	Torque - Dry	
	(lb-in)	(lb-ft)
2	204	17
3		
4		
5		
10		
15	240	27
20		
30		
40		
50	360	30
60		
70		
80		
100	900	75
120		
140		
140	7080	590

NOTE: Cap screws have self-locking patches which should not be reused more than twice. Cap screws can be further used if a thread locking adhesive is applied.

Do NOT Lubricate Cap Screw Threads.

IMPORTANT NOTE:

Coupling alignment is directly related to smooth, efficient equipment operation. Care should be taken for best possible alignment.

Omega Close-Coupled Design with Straight Bore Hubs

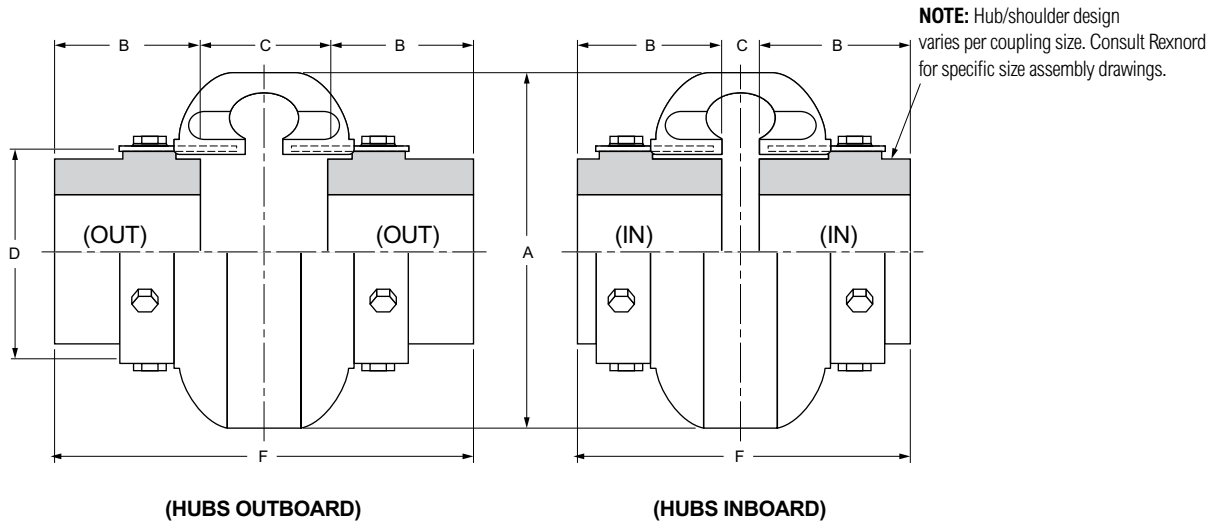

Coupling Size	Recom. Max. Bore (in) ①	Continuous HP/100 RPM	Continuous Torque (lb-in)	Max. RPM	Dimensions (in)							Weight ② (lb)
					A	B	C		D	F		
							(In)	(Out)		(In)	(Out)	
E2	1.13	0.30	190	6600	3.50	0.94	1.34	1.90	1.85	3.22	3.78	1.2
E3	1.38	0.58	365	6600	4.00	1.50	0.81	1.31	2.32	3.81	4.31	2.4
E4	1.63	0.88	550	6600	4.56	1.69	0.44	1.31	2.60	3.81	4.69	3.0
E5	1.88	1.48	925	6600	5.38	1.75	0.81	1.81	3.13	4.31	5.31	5.4
E10	2.13	2.30	1450	6600	6.38	1.88	0.56	1.84	3.65	4.31	5.56	8.2
E15	2.13	2.86	1800	6600	6.38	1.88	0.56	1.84	3.65	4.31	5.56	8.3
E20	2.38	3.65	2300	6600	7.25	2.06	0.50	2.38	4.48	4.62	6.50	13.0
E30	2.88	5.79	3650	5800	8.25	2.31	0.56	2.44	5.42	5.19	7.06	21
E40	3.38	8.85	5500	5000	9.50	2.50	0.56	2.68	6.63	5.56	7.68	35
E50	3.63	12.14	7650	4200	11.00	2.75	0.63	3.38	8.13	6.13	8.88	54
E60	4	19.84	12,500	3800	12.50	3.25	0.69	3.44	8.75	7.19	9.94	72
E70	4.5	35.12	22,125	3600	14.00	3.62	0.75	3.75	9.25	8.00	11.00	86
E80	6	62.7	39,500	2000	16.00	4.87	0.75	5.00	11.25	10.50	14.75	170
E100	6.75	135	85,050	1900	21.00	5.50	1.75	3.75	14.13	12.75	14.75	244
E120	7.5	270	170,100	1800	25.00	6.00	2.25	4.88	17.63	14.24	16.88	425
E140	9.00	540	340,200	1500	30.00	7.00	3.00	5.00	20.88	17.00	19.00	746

① See page 17 for larger bore capacities with shallow keyways.
 ② With maximum bore hubs.

Split-in-Half Flex Element

Allows disassembly and replacement without disturbing hubs or connected equipment.

Reversible Hubs

Accommodates different shaft spacing requirements, and allows compression bushings to be installed from either side of the hub.



Straight Bore Hubs



QD Hubs and Bushings



Taper-Lock Hubs and Bushings

Omega Spacer Design with Straight Bore Hubs

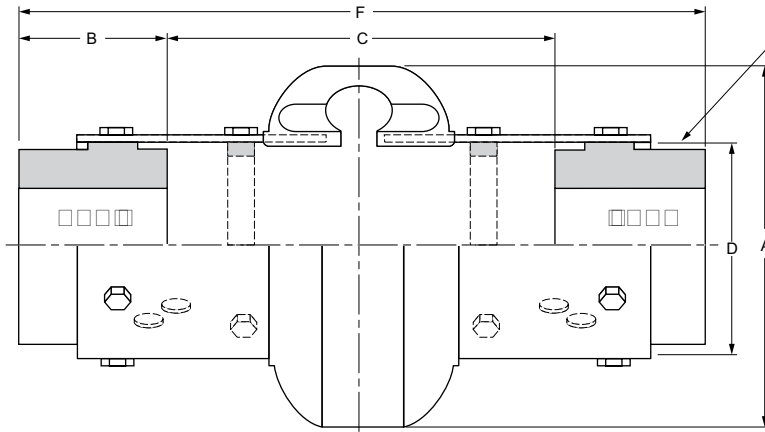

NOTE: Hub/shoulder design varies per coupling size. Consult Rexnord for specific size assembly drawings.

Coupling Size ①	Recom. Max. Bore ⑥	Continuous HP/100 RPM	Continuous Torque (lb-in)	Max. RPM ②	Dimensions (in)							Weight (lb) ⑤
					A	B	C		D	F		
							(In) ③	(Out)		(In) ④	(Out)	
ES2-R	1.13	0.30	190	6600	3.50	0.94	3.50	4.00	1.85	5.75	5.92	2.3
ES3-R	1.38	0.58	365	6600	4.00	1.50	3.50	5.00	2.32	7.25	8.00	4.0
ES4-R	1.63	0.88	550	6600	4.56	1.69	3.50	5.00	2.60	7.25	8.38	5.1
ES5-R	1.88	1.48	925	6600	5.38	1.75	3.50	5.00	3.13	7.25	8.50	7.5
ES10-R	2.13	2.30	1450	6600	6.38	1.88	3.50	5.00	3.65	7.25	8.75	10.3
ES15-R	2.13	2.86	1800	6600	6.38	1.88	3.50	5.00	3.65	7.25	8.75	10.4
ES20	2.38	3.65	2300	4800	7.25	2.06	2.55	7.00	4.48	9.38	11.12	15.6
ES30	2.88	5.79	3650	4200	8.25	2.31	2.05	7.00	5.42	9.38	11.62	25.1
ES40	3.38	8.85	5500	3600	9.50	2.50	1.67	7.00	6.63	9.38	12.00	40
ES50	3.63	12.14	7650	3100	11.00	2.75	1.17	7.00	8.13	9.38	12.50	60
ES60	4.00	19.84	12,500	2800	12.50	3.25	2.67	9.75	8.75	12.50	16.25	84
ES70	4.50	35.12	22,125	2600	14.00	3.62	1.99	9.75	9.25	12.50	17.00	102
ES80	6.00	62.70	39,500	1800	16.00	4.87	2.18	9.75	11.25	12.50	19.50	180

- ① Suffix "R" designates high speed ring design. Rings are furnished standard for sizes ES2-R to ES10-R, optional for sizes ES20 to ES80.
- ② Spacer coupling furnished with optional high speed rings (sizes ES20 to ES80) can be operated up to maximum allowable speeds for standard series couplings. See RPM Ratings on page 8.
- ③ Minimum shaft spacing is 0.25 inch. See page 12 for additional information.
- ④ Overall length of element.
- ⑤ With max bore hubs.
- ⑥ See page 17 for larger bore capacities with shallow keyways.

Adjustable Spacer Design

Optional hole mounting positions and reversible hub features allow adjustment to accommodate most shaft spacing requirements (see page 12).

Universal Hubs

Straight bore and compression bushed hub designs are identical and interchangeable for both the spacer and standard couplings. This means maximum utilization of off-the-shelf inventory.



Straight Bore Hubs



QD Hubs and Bushings



Taper-Lock Hubs and Bushings

Omega Spacer Design with Compression Bushed Hubs

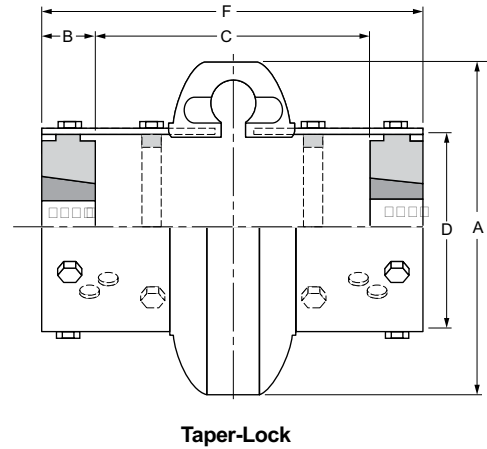
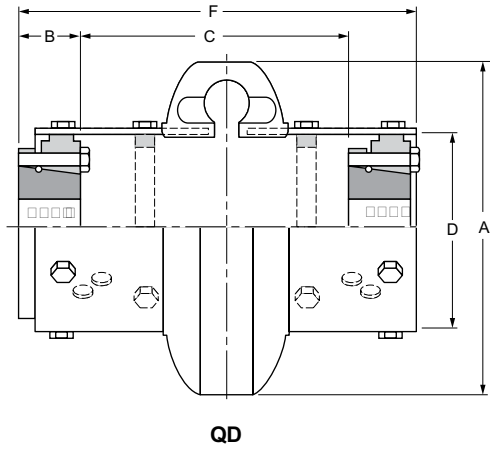

NOTE: Bushings are NOT included with hubs

Specification Data with QD Hubs

Coupling Size ①	QD Bush. No.	Recom. Max. Bore ②	Continuous HP/100 RPM	Continuous Torque (lb-in) ③	Max. RPM ④	Dimensions (in)							Weight (lb) ⑥
						A	B	C		D	F		
								(In) ⑤	(Out)		(In) ⑤	(Out)	
ES4-R	JA	1.19	0.88	550	6600	4.56	1.00	3.24	5.56	2.60	7.25	7.71	4.2
ES5-R	SH	1.63	1.48	925	6600	5.38	1.25	3.51	5.06	3.13	7.25	7.82	5.7
ES10-R	SDS	1.94	2.30	1450	6600	6.38	1.31	3.60	5.49	3.65	7.25	8.24	6.9
ES15-R	SDS	1.94	2.86	1800	6600	6.38	1.31	3.60	5.49	3.65	7.25	8.24	7.0
ES20	SK	2.50	3.65	2300	4800	7.25	1.88	2.82	6.96	4.48	9.38	10.84	11.1
ES30	SF	2.94	5.79	3650	4200	8.25	2.00	3.36	6.44	5.42	9.38	10.32	17.9
ES40	E	3.50	8.85	5500	3600	9.50	2.63	2.94	5.74	6.63	9.38	10.71	28.8
ES50	E	3.50	12.14	7650	3100	11.00	2.63	2.44	6.24	8.13	9.38	11.21	43.6
ES60	F	3.94	19.84	12,500	2800	12.50	3.63	4.25	7.68	8.75	12.50	14.65	57.4
ES70	J	4.50	35.12	22,125	2600	14.00	4.50	3.50	6.72	9.25	12.52	15.40	84.1
ES80	M	5.50	62.70	39,500	1800	16.00	6.75	1.35	4.76	11.25	14.17	17.58	150.0

NOTE: Dimensions may vary depending on bushing manufacturer.

Specification Data with Taper-Lock Hubs

Coupling Size ①	TL Bush. No.	Recom. Max. Bore ②	Continuous HP/100 RPM ③	Continuous Torque (lb-in) ③	Max. RPM ④	Dimensions (in)							Weight (lb) ⑥
						A	B	C		D	F		
								(In) ⑤	(Out)		(In) ⑤	(Out)	
ES3-R	1008	1.00	0.58	365	6600	4.00	0.88	3.83	5.38	2.32	7.25	7.25	3.2
ES4-R	1008	1.00	0.88	550	6600	4.56	0.88	3.83	5.38	2.60	7.25	7.25	4.2
ES5-R	1108	1.13	1.48	925	6600	5.38	0.88	3.83	5.38	3.13	7.25	7.25	6.0
ES10-R	1310	1.44⑦	2.30	1450	6600	6.38	1.00	3.71	5.25	3.65	7.25	7.25	7.9
ES15-R	1310	1.44⑦	2.86	1800	6600	6.38	1.00	3.71	5.25	3.65	7.25	7.25	8.0
ES20	1610	1.69⑦	3.65	2300	4800	7.25	1.00	4.84	6.75	4.48	9.38	9.38	11.9
ES30	2012	2.12⑦	5.79	3650	4200	8.25	1.25	4.59	6.50	5.42	9.38	9.38	18.0
ES40	2517	2.69⑦	8.85	5500	3600	9.50	1.75	4.09	6.00	6.63	9.38	9.59	26.8
ES50	2517	2.69⑦	12.14	7650	3100	11.00	1.75	4.09	6.00	8.13	9.38	9.59	37.4
ES60	3020	3.25⑦	19.84	12,500	2800	12.50	2.00	6.09	8.75	8.75	12.50	12.84	60.7
ES70	3535	3.94	35.12	22,125	2600	14.00	3.50	4.59	7.34	9.25	12.50	14.34	81.4
ES80	4040	4.44	62.70	39,500	1800	16.00	4.00	4.09	6.84	11.25	12.50	14.84	93.2

① Suffix "R" designates high-speed ring design. Rings are furnished standard for sizes ES2-R to ES10-R, optional for sizes ES20 to ES80.

② With shallow keyway.

③ This rating may be limited by the bushing rating if severe service conditions exist. Consult bushing manufacturer.

④ Spacer coupling furnished with optional high speed rings (sizes ES20 to ES80) can be operated up to maximum allowable speeds for standard series couplings.

⑤ Minimum shaft spacing is 0.25 inch. See **page 12** for additional information.

⑥ Without compression bushings.

⑦ With steel bushings.

NOTE: Dimensions subject to change. Certified dimensions of ordered material furnished on request.

(Catalog #4000) 11

Adjustability

Shaft Spacing Options

The Rexnord Omega spacer coupling design (pages 10-11) provides clear space between hubs. There are no interfering center members or spools which allows shaft spacing as small as 1/4"; however, for such small spacings, use of the standard Omega coupling would be recommended. The maximum shaft spacing for each coupling is shown on pages 10-11. Any ANSI, ISO or DIN spacing between 1/4 inch and the maximum listed can be achieved without any additional parts. Hubs can be placed on the shafts as shown below.

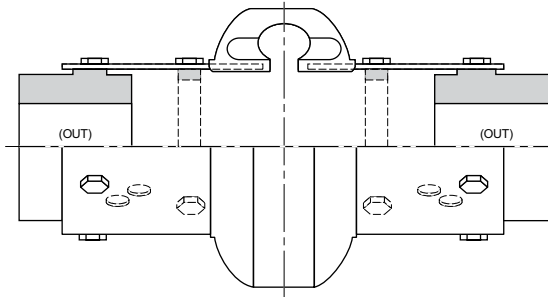

Figure A
Both hubs mounted outboard

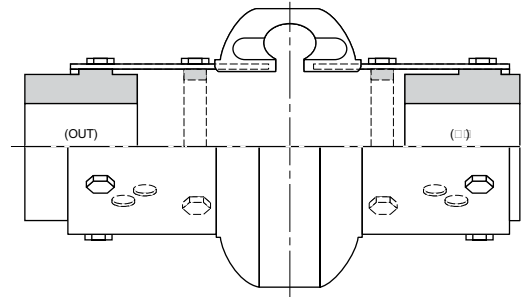

Figure B
One hub mounted inboard
One hub mounted outboard

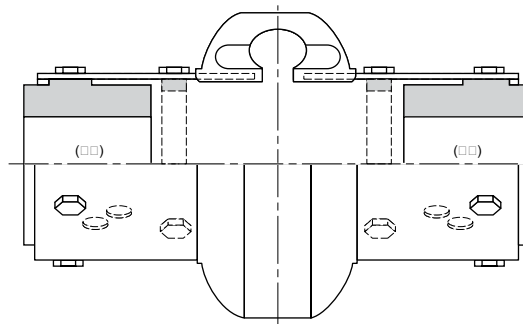

Figure C
Both hubs mounted inboard

Use one half of the flex element to establish shaft spacing and appropriate mounting position. Optional hole mounting positions and reversible hubs allow adjustments as needed. Select the combination which most closely matches the dimensions desired between shafts (Figure D). Drawings with specific mounting positions/dimensions are available from Rexnord.

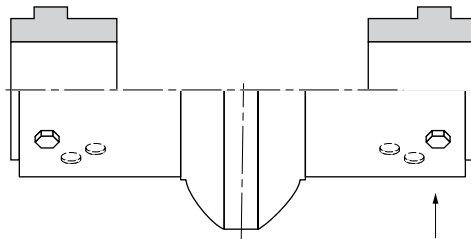

Figure D

NOTE: Optional cap screw hole mounting positions allow easy on-site adjustment to meet various shaft spacing requirements.

Hubs can be flush with the shaft end (not shown), extended beyond the end of the shaft (Figure E) or recessed behind the shaft end provided there is sufficient keyway engagement (Figure F). Special sleeve extensions (see page 13) are available for spacing requirements in excess of those listed on pages 10-11.

NOTE: Shaft engagement should be equal to or greater than 0.8 times hub length through bore. 100% shaft engagement is suggested for compression bushed hubs.

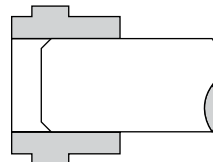

Figure E

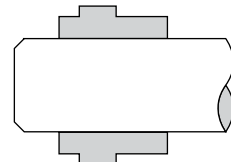
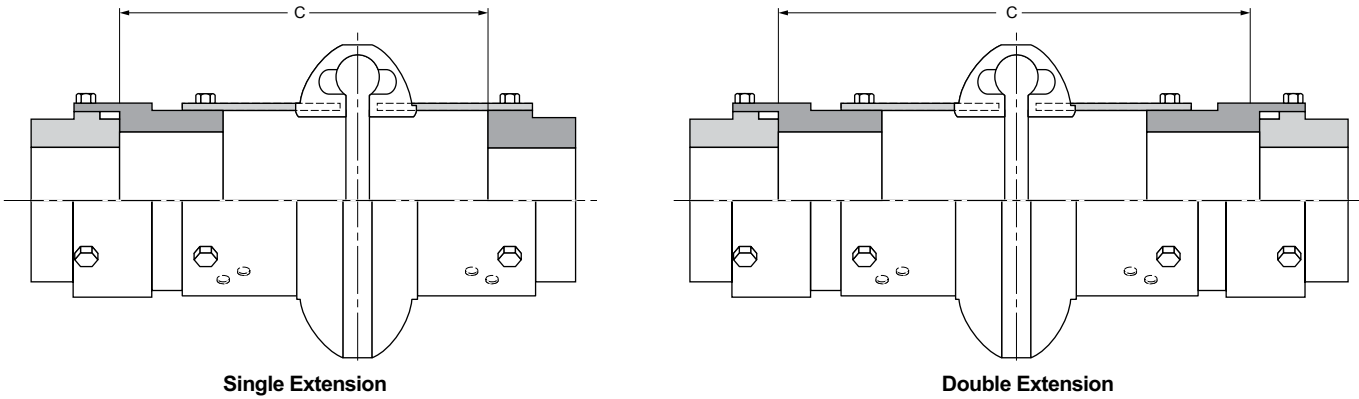

Figure F

Omega Extended Spacer Coupling

Rexnord Omega extended spacer couplings are designed to connect equipment with shaft spacing requirements beyond the Omega spacer coupling capabilities. They are ideal for applications with wide non-standard shaft gaps, and can be an economic alternative to floating shaft couplings (i.e. stock pump applications).

Sleeve extensions (“SE”) are furnished in steel. They mount to regular Omega spacer elements (standard elements for sizes E100 & E120) and straight bore or compression-bushed design. By adjusting the spacer element mounting position, the Omega extended spacer coupling can be utilized for many shaft spacing requirements.



Spacer Size	Max. RPM Standard	Max. RPM Matched Assembly ②	Maximum Spacing ① – “C” Dimension (in)									Weight (lb) One SE
			With SHRB Hubs			With HQD Hubs			With HTL Hubs			
			Max. Without SE	One SE	Two SE	Max. Without SE	One SE	Two SE	Max. Without SE	One SE	Two SE	
ES3-R	1800	3600	5.00	7.00	9.00	–	–	–	5.38	7.38	9.38	1.2
ES4-R	1800	3600	5.00	7.00	9.00	5.56	7.56	9.56	5.38	7.38	9.38	1.4
ES5-R	1800	3600	5.00	7.00	9.00	5.06	7.06	9.06	5.38	7.38	9.38	1.5
ES10-R	1800	3600	5.00	7.00	9.00	5.49	7.49	9.49	5.25	7.25	9.25	1.6
ES15-R	1800	3600	5.00	7.00	9.00	5.49	7.49	9.49	5.25	7.25	9.25	1.6
ES20	1800	3600	7.00	9.75	12.50	6.96	9.71	12.46	6.75	9.50	12.25	3.7
ES30	1800	3600	7.00	9.75	12.50	6.44	8.97	11.72	6.50	9.25	12.00	4.5
ES40	1800	3600	7.00	9.75	12.50	5.74	8.23	10.98	6.00	8.75	11.50	5.3
ES50	1800	3100	7.00	9.75	12.50	6.24	8.73	11.48	6.00	8.75	11.50	8.0
ES60	1800	2800	9.75	14.38	19.00	7.68	12.31	16.93	8.75	13.38	18.00	20.8
ES70	1800	2600	9.75	15.13	20.50	6.72	12.10	17.47	7.34	12.72	18.09	34.6
ES80	1500	1800	9.75	15.38	21.00	4.76	10.39	16.01	6.84	12.37	18.00	46.2
E100	1500	1800	3.75	8.75	13.75	1.75	7.00	12.25	6.00	11.25	16.50	76.0
E120	1500	1800	4.88	10.13	15.38	1.74	6.74	11.74	7.13	12.13	17.13	81.3
E140	1200	1500	5.00	10.50	22.00	3.00	8.50	14.00	7.00	12.50	18.00	122.0

① Maximum spacings shown are with hubs mounted outboard and flush with shaft ends. Longer custom length extensions are available; consult Rexnord.

② Hub/sleeve extension assembly precisely machined and matched to obtain higher speed rating. Specify “Matched Assembly” when ordering.

Ordering Information: When ordering, be sure to specify whether one or two sleeve extensions are required. If custom length, specify distance between shaft ends.

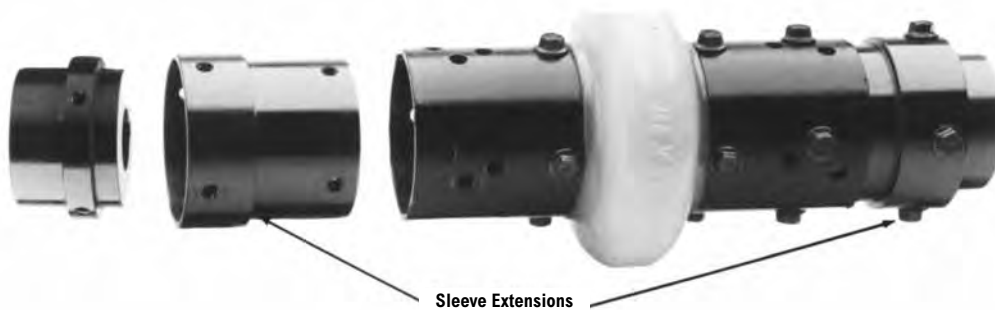

Mill Motor Couplings

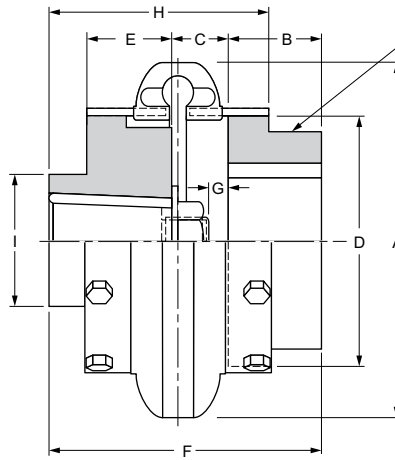

NOTE: Hub/shoulder design varies per coupling size. Consult Rexnord for specific size assembly drawings.

Mill Motor Coupling Dimensions (in)

Coupling Size	Mill Motor Size	Max. RPM	Continuous HP/100 RPM ^①	Complete Coupling Weight (lb)	Dimensions									Max. Straight Bore
					A	B	C	D	E	F	G	H	I	
10	802A	6600	2.3	15.6	6-3/8	1-7/8	1-9/32	3-5/8	3	6-5/32	1-1/32	3-3/16	2-7/8	2-1/8
	602													
20	802B	6600	3.65	25.4	7-1/4	2-1/16	1-5/8	4-1/2	3	6-11/16	9/16	4-1/4	3	2-3/8
	802C								3-1/2					
	603								6-3/8					
30	803	5800	5.79	39.3	8-1/4	2-5/16	1-1/2	5-7/16	3-1/2	7-5/16	5/8	4-9/16	3-1/2	2-7/8
	804													
	603													
	604													
40	804	5000	8.85	58.0	9-1/2	2-1/2	1-1/2	6-5/8	3-1/2	7-1/2	1/2	4-7/8	3-1/2	3-3/8
	604													
50	406	4200	12.14	83.5	11	2-3/4	1-13/16	8-1/8	4	8-9/16	11/16	5-1/2	4	3-5/8
	806													
	606								4-1/2					
	408								9-1/16					
	608								9/16					
60	406	3800	19.84	120.3	12-1/2	3-1/4	1-3/4	8-3/4	4	9	5/8	6-5/16	4-1/2	4
	806													
	408								4-1/2					
	608								9-1/2					
70	408	3600	35.12	150	14	3-5/8	2 1/2	9-1/4	4-1/2	10-5/8	1-1/4	6-7/8	4-3/4	4-1/2
	808													
	608													
	410													
	810													
	610													
	412								5					
612	11-11/16													
80	410	2000	62.7	235	16	4-7/8	3-1/8	11-1/4	4-1/2	12-1/2	1-3/4	9-1/4	6	6
	810													
	412								5					
	812								13					
	612								1-9/16					
100	614	1900	135	340	21	5-1/2	3-3/4	14-1/8	5	14-1/4	2-1/4	9-3/4	10-1/4	6-3/4
	814								2-1/8					
	616								5-1/2					
	816								14-3/4					
	618								2					
	818								14-3/4					
	818								2-7/16					
120	818	1800	270	520	25	6	4-7/8	17-5/8	6	16-7/8	3-9/16	11-9/16	11-3/4	7-1/2
	620								6					
140	622	1500	540	950	30	7	5	20-7/8	7	19	2-5/8	13	15	9
	624								7					

① Service Factor - 1.0.

Special Designs

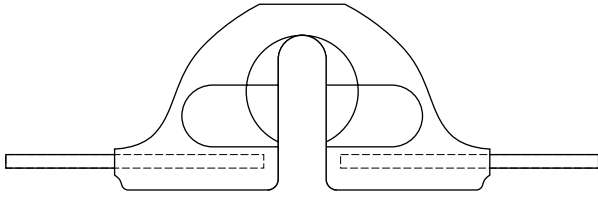

Rexnord Omega HSU Element

Hydrolytically Stable Urethane (HSU) for superior resistance to hot and humid conditions in addition to acidic and alkaline environments. The Omega HSU element is interchangeable with existing hubs.

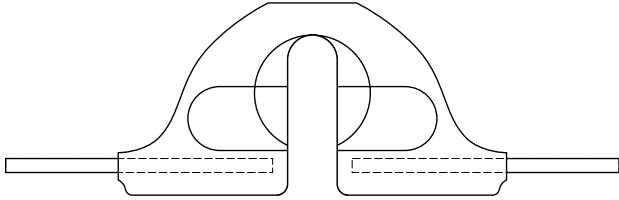

Rexnord Omega Heavy-Duty Yellow Element

25% higher torque capacity. Fits standard hubs. Available in all sizes.

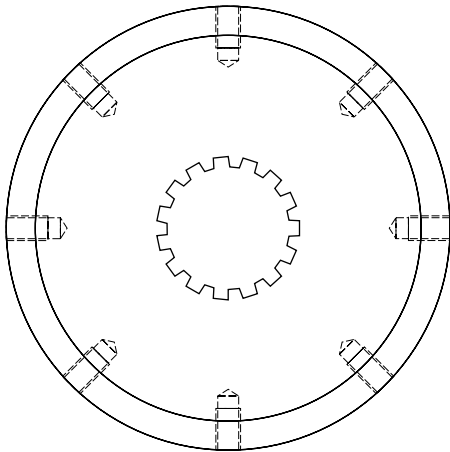

Rexnord Omega Spline Bore Hub

1. Number of Teeth – Ex. 14T
2. Pitch Fraction – Ex. 12/24 Pitch
3. Pressure Angle – 30° P.A.
4. Type of Tooth Shape – Ex. Involute or Straight Side
5. Type of Root – Ex. Fillet or Flat Root
6. Tolerance – Ex. Class I thru VII
7. Type of Fit – Ex. Side Fit or Major Diameter Fit

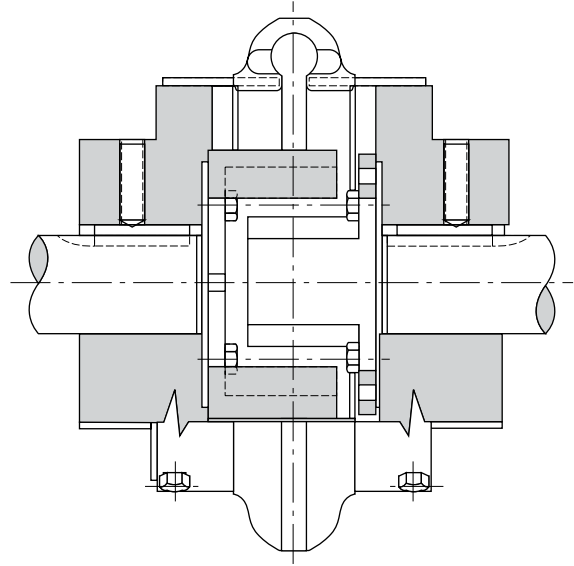

Rexnord Omega Positive Drive Coupling

With interlocking drive fail-safe requirements.

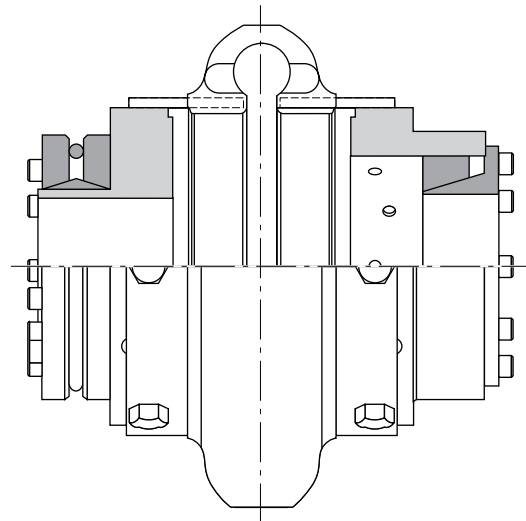

Rexnord Omega Keyless Hub/Bushing Design

Several optional keyless Hub/Bushing designs are available for increased bore end shaft gap requirements.

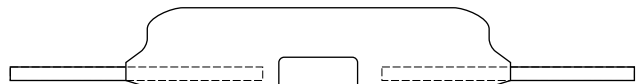

Rexnord Omega Light Duty Element

Available in size E2LD only. Minimum O.D. (2.5") for low-profile applications. Max torque rating of 100 lb-in.

Bore Specification

Couplings will be bored in accordance with AGMA Standard 9002 for flexible couplings.

Finished bore hubs will be Class 1 clearance fit unless otherwise specified.

Shaft Dia.	Class 1 Clearance Fit	Interference Fit	Shaft Dia.	Class 1 Clearance Fit	Interference Fit
1/2	0.500-0.501	0.4990-0.4995	2-3/8	2.3750-2.3765	2.373-2.374
5/8	0.625-0.626	0.6240-0.6245	2-1/2	2.5000-2.5015	2.498-2.499
3/4	0.750-0.751	0.7490-0.7495	2-5/8	2.6250-2.6265	2.623-2.624
7/8	0.875-0.876	0.8740-0.8745	2-3/4	2.7500-2.7515	2.748-2.749
1	1.000-1.001	0.9990-0.9995	2-7/8	2.8750-2.8765	2.873-2.874
1-1/8	1.125-1.126	1.1240-1.1245	3	3.0000-3.0015	2.998-2.999
1-1/4	1.250-1.251	1.2490-1.2495	3-1/4	3.2500-3.2515	3.2470-3.2485
1-3/8	1.375-1.376	1.3740-1.3745	3-1/2	3.5000-3.5015	3.4970-3.4985
1-1/2	1.500-1.501	1.4990-1.4995	3-5/8	3.6250-3.6265	3.6220-3.6235
1-5/8	1.625-1.626	1.623-1.624	3-3/4	3.7500-3.7515	3.7470-3.7485
1-3/4	1.750-1.751	1.748-1.749	4	4.0000-4.0015	3.9970-3.9985
1-7/8	1.875-1.876	1.873-1.874	4-1/2	4.5000-4.502	4.4965-4.4980
2	2.000-2.001	1.998-1.999	5	5.0000-5.002	4.9965-4.9980
2-1/8	2.1250-2.1265	2.123-2.124	5-1/2	5.5000-5.502	5.4960-5.4975
2-1/4	2.2500-2.2515	2.248-2.249	6	6.0000-6.002	5.9960-5.9975

Bore Sizes (in)

Nominal Shaft Diameter		Key			Setscrew Dia. Class 2B NC Thread	Recommended Tightening Torque (lb-in)
		Width	Depth			
Over	Thru		Sq.	Rect.		
5/16	7/16	3/32	3/64	—	1/4 - 20	87
7/16	9/16	1/8	1/16	3/64		
9/16	7/8	3/16	3/32	1/16		
7/8	1-1/4	1/4	1/8	3/32	3/8 - 16①	290
1-1/4	1-3/8	5/16	5/32	1/8		
1-3/8	1-3/4	3/8	3/16	1/8		
1-3/4	2-1/4	1/2	1/4	3/16	1/2 - 13②	620
2-1/4	2-3/4	5/8	5/16	7/32	5/8 - 11	1325
2-3/4	3-1/4	3/4	3/4	1/4	3/4 - 10	2400
3-1/4	3-3/4	7/8	7/8	5/16	7/8 - 9	5200
3-3/4	4-1/2	1	1/2	3/8	1-8	7200
4-1/2	5-1/2	1-1/4	5/8	7/16		
5-1/2	6-1/2	1-1/2	3/4	1/2		
6-1/2	7-1/2	1-3/4	7/8	3/4		
7-1/2	9	2	1	3/4		

① Maximum setscrew diameter in 1/4 - 20 UNC for size #2 hub.

② Maximum setscrew size for hub size #3 thru #10 is 3/8 - 16 UNC.

Finished Stock Bore Hub Part Numbers

(Straight bore hubs bored in accordance with AGMA Standard 9002 Class 1 Clearance Fit)

Size Bore	2 HSB	3 HSB	4 HSB	5 HSB	10 HSB	15 HSB	20 HSB	30 HSB	40 HSB	50 HSB	60 HSB
5/8	7300218	7300242	7300272	—	—	—	—	—	—	—	—
3/4	7300220	7300244	7300274	7300306	—	—	—	—	—	—	—
7/8	7300225	7300245	7300275	7300308	7385821	—	—	—	—	—	—
1-5/16	—	—	7300276	7300309	—	—	—	—	—	—	—
1	7300230	7300250	7300280	7300310	7385820	—	—	—	—	—	—
1-1/16	—	—	—	7300312	—	—	—	—	—	—	—
1-1/8	7300235	7300255	7300285	7300315	7300345	—	7300649	7385825	—	—	—
1-3/16	—	—	7300286	7300318	—	—	—	—	—	—	—
1-1/4	—	7300260	7300290	7300320	7300350	—	7300651	7385822	—	—	—
1-5/16	—	—	—	7300322	—	—	—	—	—	—	—
1-3/8	—	7300265	7300295	7300325	7300355	—	7300963	7385823	—	—	—
1-7/16	—	—	7300296	7300326	7300356	—	—	—	—	—	—
1-1/2	—	—	7300298	7300328	7300358	—	7300652	7300661	7300669	—	—
1-9/16	—	—	7300299	—	7300359	—	—	—	—	—	—
1-5/8	—	—	7300300	7300330	7300360	—	7300653	7369351	7369352	—	—
1-11/16	—	—	—	7300332	7300361	—	7300656	7300964	—	—	—
1-3/4	—	—	—	7300333	7300362	—	7300654	7300663	7300672	7300681	—
1-7/8	—	—	—	7300335	7300365	—	7300655	7300662	7300671	7300684	—
1-15/16	—	—	—	—	7300366	—	7390410	—	—	—	—
2	—	—	—	—	7300368	—	7390411	7390413	7390417	—	7390417
2-1/8	—	—	—	—	7300370	—	7300657	7300664	7300673	7300961	7390418
2-3/16	—	—	—	—	—	—	7390412	—	—	—	—
2-1/4	—	—	—	—	—	—	7300658	7300665	7300674	7300682	—
2-3/8	—	—	—	—	—	—	7300659	7300666	7300675	7300962	7300691
2-1/2	—	—	—	—	—	—	—	7300667	7300676	—	—
2-11/16	—	—	—	—	—	—	—	7300965	7300678	—	—
2-3/4	—	—	—	—	—	—	—	7390414	7390415	—	—
2-7/8	—	—	—	—	—	—	—	7300668	7300677	7300683	7300692
3-5/16	—	—	—	—	—	—	—	—	—	7300685	7300693
3-3/8	—	—	—	—	—	—	—	—	7300679	7300686	7300694

Coupling Selection

Bore Ranges (in)

Hub Size	Straight Bore		Taper-Lock ①			QD ① ②		
	Min. Bore ②	Max. Bore ③	Bushing Number	Min. Bore	Max. Bore ③	Bushing Number	Min. Bore	Max. Bore ③
2	No Min.	1-3/16	NA	—	—	NA	—	—
3	3/8	1-3/8	1008	1/2	1	NA	—	—
4	3/8	1-3/4	1008	1/2	1	JA	3/8	1-3/16
5	3/8	1-15/16	1108	1/2	1-1/8	SH	1/2	1-5/8
10	3/8	2-1/4	1310	1/2	1-7/16	SDS	1/2	1-15/16
15	3/8	2-1/4	1310	1/2	1-7/16	SDS	1/2	1-15/16
20	3/4	2-3/4	1610	1/2	1-11/16	SK	1/2	2-1/2
30	3/4	3-1/4	2012	1/2	2-1/8	SF	1/2	2-15/16
40	3/4	3-3/4	2517	1/2	2-11/16	E	7/8	3-1/2
50	1-1/8	4	2517	1/2	2-11/16	E	7/8	3-1/2
60	1-1/8	4-1/2	3020	15/16	3-1/4	F	1	3-15/16
70	1-3/8	4-7/8	3535	1-3/16	3-15/16	J	1-7/16	4-1/2
80	1-7/8	6-3/4	4040	1-7/16	4-7/16	M	1-15/16	5-1/2
100	1-7/8	7-1/4	4545	1-15/16	4-15/16	M	1-15/16	5-1/2
120	1-7/8	8-1/4	5050	2-5/16	6	N	2-7/16	6
140	1-7/8	9-1/4	7060	4-9/16	7	P	2-15/16	7

- ① Bushings are not included with bushed hubs. Bushing bore ranges may vary, check with bushing manufacturer.
 ② Rough bores are slightly undersized to conform with minimum bore specifications.
 ③ With shallow keyway and steel hub and steel bushing.

Omega Couplings Interchange ④

Omega	Dodge Para-Flex	Lovejoy (Rubber)	TB Woods (Rubber)	Falk Grid			Kop-Flex Gear
				1000T	10T	F	
2	—	L-095	5	1020T	20T	3	1H
3	—	L-099, L-100	6	1030T	30T	4	1H
4	—	L-110	7	1040T	40T	4	1H
5	50	L-110	8	1040T, 1050T	40T, 50T	5, 6	1H, 1-1/2H
10	60	L-150, L-190	9	1050T, 1060T	50T, 60T	7, 8	1-1/2H
15	60	L-150, L-190	9	1050T, 1060T	50T, 60T	7, 8	1-1/2H
20	70	L-225	10	1060T, 1070T	60T, 70T	8, 9	1-1/2H, 2H
30	80	L-276	11	1070T, 1080T	70T, 80T	9, 10	2H, 2-1/2H
40	90	—	12	1090T	90T	10	2-1/2H
50	110	—	—	1090T	90T	11	2-1/2H
60	120	—	13	1090T	90T	11	2-1/2H
70	140	—	14	1100T	100T	13	3H
80	160	—	16	1110T	110T	14	3H
100	200	—	NA	1120T	120T	15	⑤
120	240	—	NA	1130T, 1140T	130T, 140T	16, 17	⑤
140	280	—	NA	1150T	150T	18	⑤

- ④ **CAUTION** should be applied when using any interchange chart (particularly with respect to gear and grid couplings) since each product has different dimensions, benefits and service factor recommendations. This interchange is based on typical specifications for centrifugal pump applications at 1750 RPM. For specific applications, consult Rexnord, refer to **page 4**, or ask for our free Slide Selector. Use this chart as a general guide.
 ⑤ Consult Rexnord.



866-REXNORD/866-739-6673 (Within the US)
414-643-2366 (Outside the US)
www.rexnord.com

Why Choose Rexnord?

When it comes to providing highly engineered products that improve productivity and efficiency for industrial applications worldwide, Rexnord is the most reliable in the industry. Commitment to customer satisfaction and superior value extend across every business function.

Delivering Lowest Total Cost of Ownership

The highest quality products are designed to help prevent equipment downtime and increase productivity and dependable operation.

Valuable Expertise

An extensive product offering is accompanied by global sales specialists, customer service and maintenance support teams, available anytime.

Solutions to Enhance Ease of Doing Business

Commitment to operational excellence ensures the right products at the right place at the right time.

REXNORD

Rexnord Company Overview

Rexnord is a growth-oriented, multi-platform industrial company with leading market shares and highly trusted brands that serve a diverse array of global end markets.

Process and Motion Control

The Rexnord Process & Motion Control platform designs, manufactures, markets and services specified, highly engineered mechanical components used within complex systems where our customers' reliability requirements and the cost of failure or downtime are extremely high.

Water Management

The Rexnord Water Management platform designs, procures, manufactures and markets products that provide and enhance water quality, safety, flow control and conservation.